

§27. Experimental Study on Liquid Lithium Flow for IFMIF Target

Horiike, H., Kondo, H., Yamaoka, N., Miyamoto, S., Yamanaka, S., Takahama, H., Kanemura, T. (Graduate School of Eng. Osaka Univ.),
 Ida, M., Nakamura, H., Ara, K. (Japan Atomic Energy Agency),
 Matsui, H. (Tohoku Univ.),
 Suzuki, A. (Tokyo Univ.),
 Tanaka, T., Kondo, M., Muroga, T.

In the design of IFMIF, a liquid Li of 25 mm in depth, and 260 mm in width, with a flow velocity of 10 to 20 m/s is considered to be the beam target. Investigation of characteristics of free surface liquid Li flow is important for the design of the actual target system, and also for liquid Li fusion blanket systems.

In this report, surface fluctuations on the Li free surface were measured by using an electro-contact probe. As a result, distribution and average of height of the surface waves generated on the Li flow were successfully clarified.

Test section of the Li loop at Osaka University consists of honeycomb and perforated plates, a two-stage contraction nozzle, and a flow channel as shown in Fig.1. Li free surface flow of 10 mm in depth and 70 mm in width is formed by the nozzle. The flow channel is placed horizontally.

The surface fluctuations, mainly caused by waves generated on the surface, were measured by using the electro-contact probe at 175 mm downstream from the nozzle. The setting of the electro-contact probe is also shown in Fig.1. Electric contact of the needle tip to Li surface indicates local height of the surface. Detail of the setting and measurement method of the electro-contact probe was described in Ref [1] and [2].

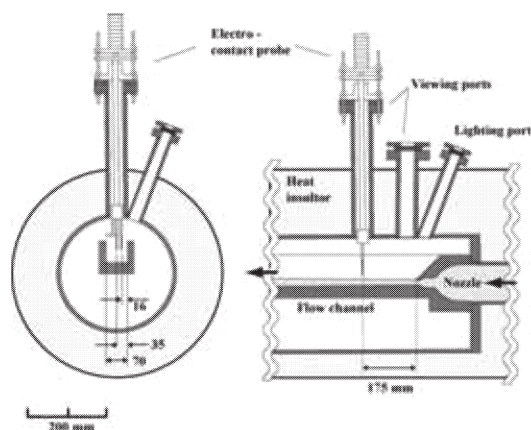

Fig.1. Schematic of Free surface test section and electro-contact probe

Figure 2 shows measurement results of the wave height against the flow velocity. Irregular waves were generated on the flow surface. Circles show the average height of the waves, which were calculated from distributions of

frequency of contacts between the probe and the waves. It is found to increase with an increase of the flow velocity and leads to 0.9 mm at the velocity of 15 mm. The significant wave, that is representative wave height of irregular wave train, was denoted by triangles. Maximum of the wave height was defined as range of the contact that is also described in Ref [1] and [2], and was denoted by squares. It is seen that the maximum was 4 times larger than the average.

Distributions of the wave height in the irregular wave train of the varied flow velocity were successfully obtained from the frequency of the contacts. Figure 3 shows the distributions summarized in non-dimensional form of wave height against probability. The obtained distributions of the wave height agreed well with Rayleigh distribution denoted by the solid line. Major characteristics of the waves were successfully clarified.

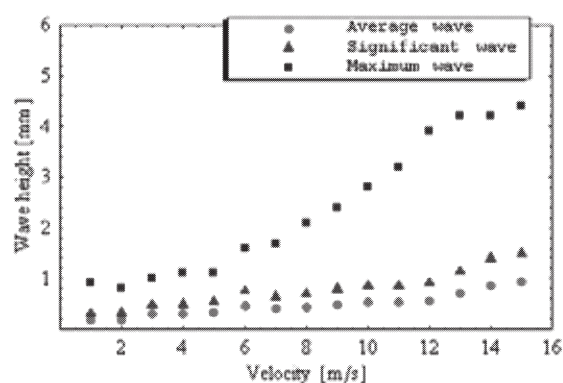

Fig.2. Average of the wave height against velocity

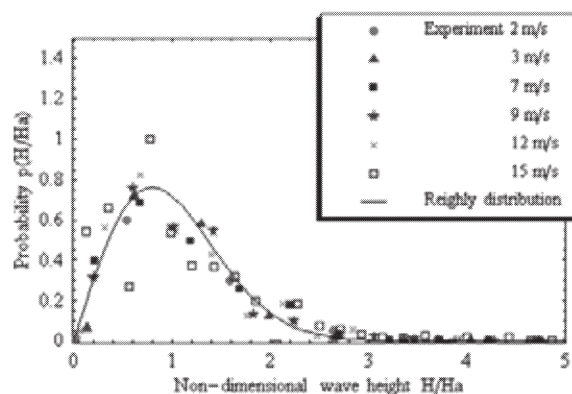

Fig.3. Distribution of the wave height

Reference

- [1] T. Kanemura, H. Kondo, T. Muroga, H. Horiike, et al. "Investigation of free-surface fluctuations of liquid lithium flow for IFMIF lithium target by using an electro-contact probe", To be published in Fus. Eng.
 [2] H. Horiike, H. Kondo, T. Muroga, et al. "Free-Surface Fluctuation at High Speed Lithium Flow for IFMIF", Proc. 21st IAEA Fusion Energy Conference, Chengdu, China, 16-21 Oct 2006