

§32. Accuracy Enhancement of Simple System of Millimeter-wave Interferometer for Low Density Plasmas

Sanpei, A., Himura, H., Masamune, S. (Kyoto Inst. Tech.),
Ejiri, A. (Univ. Tokyo),
Akiyama, T., Suzuki, C.

Measurement of electron density profile of the edge and divertor plasma is very important issue for study of fusion plasma physics. In 2009, we had developed a cross detector which simultaneously detects reference and transmitted waves from two ports. The use of cross detector has lead to improved accuracy in the phase shift measurement. One of the important issues of this study is the development of multi channel measurement system, which will be applied for low density regime such as divertor plasma of LHD. Developed an interferometer system was applied for a low aspect ratio (A) reversed field pinch (RFP) plasma, then obtained a preliminary experimental result¹⁾. However, an analysis from the obtained experimental result is less-accurate because attenuation of transmitted wave is more likely to occur with electron density closed to cuto density. In order to accurize our system, in this study, we have adopted an up-converter system. All data are obtained from the low- A RFP device, REversed field pinch of Low Aspect eXperiment (RELAX)^{2, 3)}, which has low electron density 10^{18-19} .

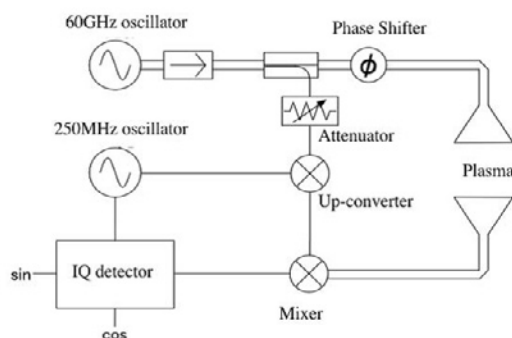

Fig. 1: Schematic of the developed up-converter interferometer system.

The schematic of developed up-converter system is shown in Fig.1. In this study, we choose 60 GHz microwave oscillator. The microwave oscillator is IMPATT diode (HUGES, 47174H-1280), which has maximum power 25.4 dBm. In order to protect the oscillator from reflected wave, an isolator is inserted on circuit. A directional coupler (HUGES, 45324H-1210) splits the microwave to probe and reference signals. Some frequency synthesizers have been used to accurize the pick-up waves. By comparison the Lissajous figure from the

developing up-converter system with that from the existing cross detector systems, we may expect that the developing up-converter system has more accuracy with electron density closed to cuto density. Experimental verification is in progress.

Another issue of this collaborative work is measurement of the electron density of RELAX with an interferometer, which is a 104 GHz heterodyne system on loan from the TST group at the University of Tokyo. The detailed density measurement has been performed using the heterodyne system consisting of two (104.00 GHz and 104.45 GHz) gun oscillators. The frequency of both the transmitted and reference waves are converted to the intermediate frequency, IF (450 MHz) with mixers. The IF signals are then amplified and are mixed with an IQ detector whose outputs are cosine and sine components of the phase shift caused by the plasma. We should note that the cuto electron density for 104 GHz is $1.34 \times 10^{20} \text{m}^{-3}$. Figure 2 shows a sample of time evolutions of I_p and line averaged electron density n_e measured using the 104 GHz interferometer in RELAX plasma. Comparison the developing up-converter system with the 104GHz heterodyne remains as future work.

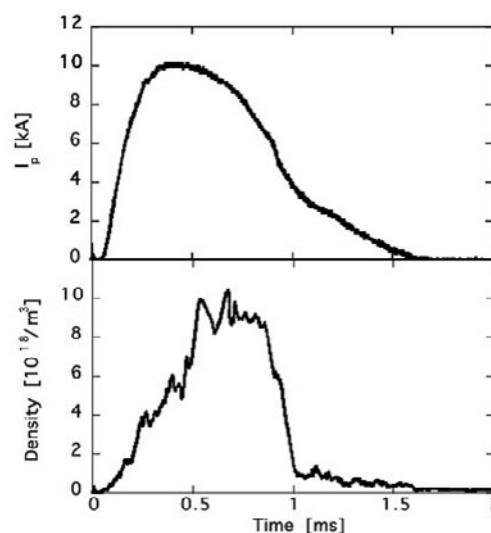

Fig. 2: Time evolution of plasma current and line averaged electron density.

- 1) M. Sugihara *et al.*, Plasma Fusion Res., **5**, S2061 (2010).
- 2) S. Masamune *et al.*, Trans. of Fusion Sci. Technol. **51** (No. 2T) (2007) 197.
- 3) S. Masamune *et al.*, J. Phys. Soc. Jpn. **76** (No.12) (2007) 123501.