

## §67. Study on High Current Density Junction between Superconducting Composite Conductors

Onishi, T., Okumura, A., Nii, A. (Dept. Elect. Eng., Hokkaido Univ.)

The improvement of the critical current density in a hybrid conductor composed of both the Cu-clad NbTi superconducting wire (LTS) and Ag-sheathed BSCCO-2223 wire (HTS) were investigated with both the experiments and computer simulations in order to establish the high performance junction between superconducting composite conductors. The experimental method and the results were reported elsewhere[1]. A computer simulation model was developed and the stabilities of the hybrid conductor were analysed by the finite difference method this year. The conductor was modeled by an equivalent circuit consisting of a series-parallel resistive network shown in Fig.1. The branches marked 1,2 and 3 are respectively HTS, LTS and a silver sheath. At a point  $x$ , a heat generation by Joule heating per unit length  $g(\theta)$  is given as,

$$g(\theta) = R_1 I_1^2 + R_2 I_2^2 + R_3 (I - I_1 - I_2)^2 + (dl/dx)^2 R_4 \quad (1)$$

A temperature of the conductor  $\theta = \theta(x, t)$  at  $x$  and time  $t$  will be governed in an one dimensional approximation by,

$$Ak(\theta) \frac{\partial^2 \theta}{\partial x^2} - AC(\theta) \frac{\partial \theta}{\partial t} + g(\theta) - Pq(\theta) + \eta(x, t) = 0 \quad (2)$$

where  $q(\theta)$  is a cooling heat flux to liquid helium per unit surface area of the conductor,  $P$  a cooling perimeter and  $\eta(x, t)$  a thermal disturbance.  $A$ ,  $C(\theta)$  and  $k(\theta)$  are respectively the cross sectional area, the heat capacity and the thermal conductivity of the conductor. The thermal disturbance  $\eta(x, t)$  has a constant value of  $\eta_{ini}$  at a range of  $|x| < 10^{-2} m$  during 100ms. The simulations were carried out at the magnetic fields. The voltage traces obtained both

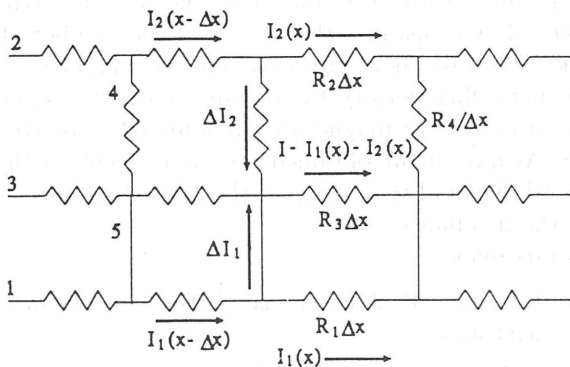

Fig.1 Equivalent circuit of a hybrid superconductor

by the experiments and simulations are shown in Figs.2a and 2b. Figs.2a and 2b show the voltages at the transport currents of 170A and 195 A at 1T, respectively [2]. The former indicates the recovery to a superconducting state, while the latter does a quench. From those results, the normal propagation velocities  $V_p$  are obtained, and the calculated values are well consistent with the experimental ones. The current at  $V_p=0$  is equal to the cold end recovery current, giving a measure of the conductor stability. For the case of the conductor without HTS, the recovery current obtained was 163 A, while it was about 181A for the hybrid conductor. This means that the stability of the hybrid conductor was improved by about 10%. The improvement depends on the amount of HTS. It was shown that the hybrid conductor is considerably effective for the stability improvement. The present simulation method will be applied to the evaluation of the stability in the junction between the superconducting wires with a large current carrying capacity hereafter.

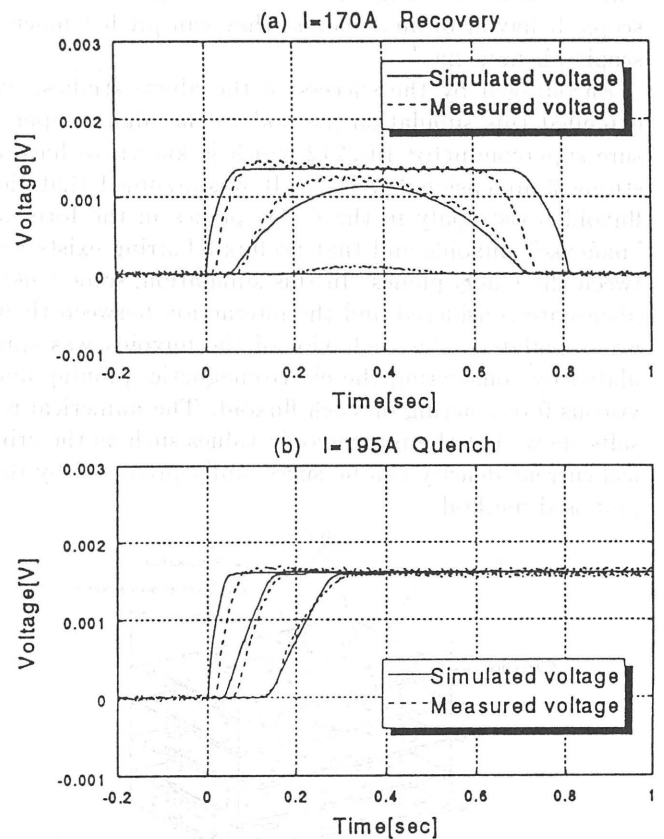

Fig.2 Voltage traces at various points from a heater. (a)  $I=170A$ , (b)  $I=195A$ .

### References

- 1) Onishi, T : Annual Report of National Institute for Fusion Science [April 1996 - March 1997]
- 3) Okumura, A, Nii, A, Onishi, T : Proc. Symp. on Applied Electromagnetics, Power System and Controls [Korea, Dec., 1997]