

§4. Feasibility Study on SMES Systems Using Stress-Minimized Helical Coils

Nomura, S., Tsutsui, H., Tsuji-Iio, S., Shimada, R. (Tokyo Tech.), Chikaraishi, H.

Design considerations for large-scale SMES that has same stored capacity of pumped hydro storage have been discussed [1, 2]. Fig. 1 indicates a schematic diagram of the back-to-back (BTB) interconnection with SMES based on the force-balanced coil (FBC) design. The FBC is a helically wound hybrid coil of toroidal field coils and a solenoid. The FBC is an optimal SMES coil that can minimize the required mass of the structure for induced electromagnetic forces. Since the BTB interconnection already has AC/DC converters, by using superconducting coils instead of DC reactors, the SMES can be easily incorporated into the BTB interconnection. The suggested system enables flexible power interchange between interconnected power networks.

Fig. 2 shows a schematic illustration of the BTB interconnection with 600-MWh SMES based on the FBC design. In the case of large-scale SMES, the superconducting coils require special structural considerations for induced electromagnetic forces, such as bedrock support. In order to reduce the risk in the coil manufacturing process, the 600-MWh is composed of 4000 superconducting coils. Each coil has the stored energy of 150 kWh (540 MJ). When the several SMES coils have been constructed, these coils will be put into operation immediately. Then the stored energy can be continuously enlarged.

In order to demonstrate the feasibility of the FBC concept for large-scale SMES, a one tenth sized model coil of the 150-kWh SMES coil has been designed [3]. The model coil with an outer diameter of 0.53 m will have

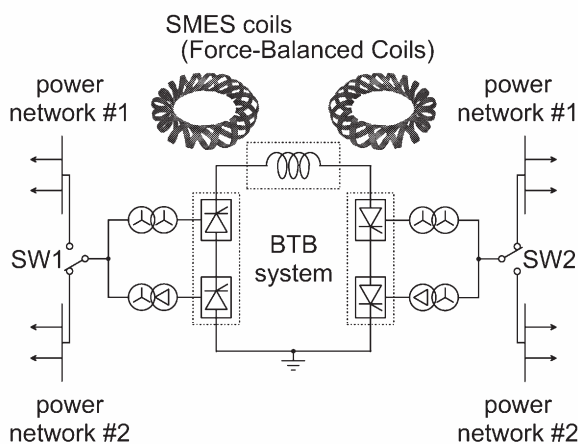

Figure 1: Schematic diagram of the BTB interconnection with the SMES.

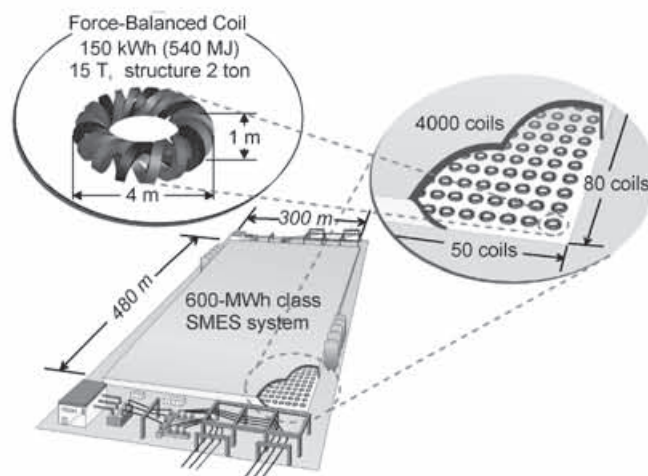

Figure 2: Schematic illustration of the 600-MWh SMES based on the FBC design.



Figure 3: Winding form for the model coil.

270-kJ stored energy at the maximum magnetic field of 7.0 T using NbTi superconductors. Fig. 3 shows a photograph of the winding form made of aluminum alloy. In this demonstration, the winding of the model coil will be carried out without reinforcing materials for the NbTi superconductors, and the mechanical properties of the model coil will be investigated.

References

- [1] S. Nomura, T. Hagita, H. Tsutsui, Y. Sato, R. Shimada, "Interconnected Power Systems with Superconducting Magnetic Energy Storage," *IEEJ Trans. Power and Energy* **126** (2) (2006) pp. 251–256 (in Japanese).
- [2] S. Nomura, H. Tsutsui, S. Tsuji-Iio, R. Shimada, "Flexible Power Interconnection With SMES," *IEEE Trans. Applied Superconductivity* **16** (2) (2006) pp. 616–619.
- [3] S. Nomura, H. Tsutsui, S. Tsuji-Iio, H. Chikaraishi, R. Shimada, "Feasibility Study on High Field Magnets Using Stress-Minimized Helical Coils," to be published in *Fusion Engineering and Design*.