

## §42. Compact Toroid Injection into Spherical Tokamak Plasmas in the Small PWI Device

Nagata, M., Fukumoto, N. (Univ. Hyogo),  
Masamune, S., Sanpei, A. (Kyoto Inst. Tech.),  
Asai, T. (Nihon Univ.),  
Kanki, T. (Japan Coast Guard Academy),  
Hanada, K. (Kyushu Univ.)

One of important issues on fusion programs is to develop a reliable fuelling technology for fusion reactor. Conventional particle fuelling schemes such as continuous gas puffing and pellet injection have been sufficient to fuel the existing fusion devices. However, they may be inadequate for central fuelling in fusion reactors. A large portion of fuel deposited in the edge will not reach the core region and accumulate on the vessel walls of the reactor. The central deposition is required to reduce the tritium accumulation and maximize a fuelling efficiency. Compact toroid (CT) injection appears to be capable of this task as the advanced particle fuelling methods for fusion plasmas. So far, several CT injectors were constructed and tested on various tokamaks including TdeV, STOR-M, TEXT-U, etc. in Canada and U.S.A. In Japan, CT injection programs were carried out in the JFT-2M tokamak at JAERI by our group at Himeji Institute of Technology (now University of Hyogo) [1-4]. In a series of CT injection experiments (1998 – 2004) on JFT-2M, we achieved significant progress. At present, a test of CT injection on a relatively large fusion device is strongly desirable, but it is unfortunately difficult to realize it soon. Before doing the test on large devices, there are several key issues that need to be resolved. First one of them is to identify fuelling mechanism of CT particle. Such a basic research is applicable for even a small-size fusion device. Finding a complex mechanism of CT fuelling process becomes a pioneering work as laboratory reconnection experiments also. The long term objective is to make CT injection a fuelling technology applicable for ITER. From this year, we have started the collaboration on CT injection experiments into spherical tokamak (ST) plasmas in the CPD device which was built at Kyushu university. This research is connected with developing the SPICA injector for fuelling LHD at NIFS.

The main objectives of this research collaboration are as follows; (1) Detailed understandings of complicate interactions involving magnetic reconnection process between the injected CT and ST plasmas. (2) Testing of CT injection into the ST plasma including deep fuelling, plasma rotation and control of plasma pressure profile (3) Demonstration of non-inductive current start-up of ST plasmas by CT injection. (4) Studies of two-fluid effects of the ST plasma in which a toroidal flow is driven by a tangential CT injection. CT injector and its power supply are used the same as on JFT-2M. Note that it becomes much easier to do precision control of CT particle inventory and velocity as compared to experiments on JFT-2M because the toroidal magnetic field energy of the

ST is much smaller than that of a conventional tokamak as shown by Fig. 1.

The main work in the starting year is to move the total CT injection system to Kyusyu university from JAERI. It has been successfully completed at the beginning of November 2007. The power supplies consist of fast capacitor banks of formation (20kV, 144 $\mu$ F) and acceleration (40kV, 92.4 $\mu$ F) of CT plasma and slow capacitor banks of bias coils (2.4kV, 34mF) and 4 gas puff valves (5kV, 4x320 $\mu$ F). After the set-up of the CT injector and those capacitor banks and a vacuum pumping system around the CPD device (see Fig. 2), we checked if the performance of CT injector keeps the same high level as in the experiments on JFT-2M. After replacement of several ignitlons, we confirmed that it can be still operated with the best condition (the acceleration current 260 kA at 20 kV, the formation current 200 kA at 10 kV).

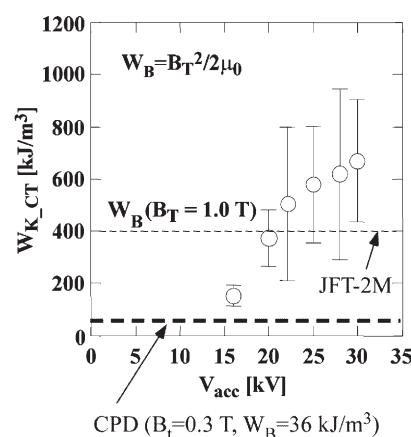

Fig.1 Performance of the CT injector used on JFT-2M [4]. Kinetic energy  $W_{K-CT}$  of CT is as a function of the acceleration bank voltage  $V_{acc}$ . For a deep penetration,  $W_{K-CT}$  must be larger than the magnetic energy of the toroidal field  $B_T$ . The condition is satisfied enough for CPD.

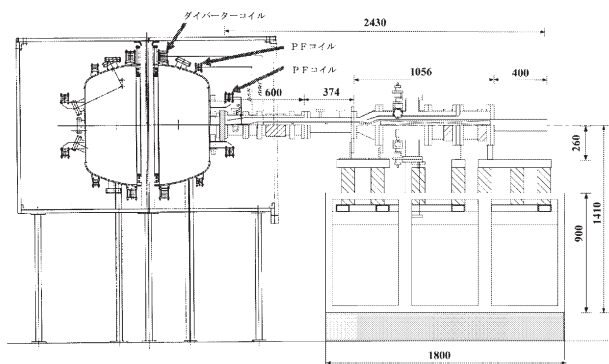

Fig.2 Schematic drawing of the CT injector and the CPD device.

### References

- [1] M. Nagata, et al., Nuclear Fusion **41**, 1687 (2001).
- [2] N. Fukumoto, et al., Nuclear Fusion **43**, 982-986 (2004).
- [3] N. Fukumoto, et al., Fusion Engineering and Design, **70**, 289-297 (2004).
- [4] M. Nagata, et al., Nuclear Fusion **45**, 1056-1060 (2005).