

§20. Fast RF Spectrometer System on LHD

Yun, G. (POSTECH), Akiyama, T.

Fast RF spectrometer system has been developed for LHD to investigate the low frequency RF radiation (from ~100 MHz to a few GHz) from the plasma. This collaborative research is an extension of the previous work at the KSTAR tokamak [1], where RF emissions in the whistler wave frequency range were observed at every ELM crash, large sawtooth crashes, and during L/H transitions.

Fig.1 shows a broadband dipole antenna installed on the 10-O port of LHD. The spectra of the antenna signals are measured in μs time resolution by a 14-channel filter bank spectrometer in the range of 70 – 2800 MHz. In addition to the dipole antenna, a wide-band bow-tie antenna is installed outside the vacuum vessel as shown in Fig. 2. The frequency band of the bow-tie antenna is 200-2000 MHz and the VSWR is less than 2. This bow-tie antenna was made by prof. K.W. Kim (Kyungpook National University) and is the same as that installed on KSTAR. This outer vessel antenna can detect the RF waves which come out through the vacuum window for the dispersion interferometer in front of the bow-tie antenna. The arrangement of the antenna and the window is similar to that on KSTAR. An ADC and a spectrometer were added for the bow-tie antenna and the dipole and bow-tie antennas can measure the radiation simultaneously.

So far the RF radiations which may be related to the ripple-trapped particles have been detected with the RF spectrometer [2]. The detected RF signal level increases significantly during the injection of NBI#5, which is located in proximity to the RF antenna, whereas the RF signal level is hardly affected by the NBI#4. It is speculated that the trapped high energy particles, which originate from the NB injection, exist only near NB injection port where they can radiate RF waves. Since the NBI#4 is located almost opposite side of the torus to the antenna, the detected radiation level is smaller than that during NBI#5. Fig. 3 show the RF radiation during an EIC mode, which is an interchange mode driven by ripple-trapped energetic particles [3]. Coincident with the onset of magnetic oscillations, the RF radiation increases. Oscillations in the magnetic probe are also observed in the RF radiation. The decay time of the burst depends on the frequency. The radiation with a frequency of the 300 MHz has the longest decay time. Since this radiation is expected to attribute to the ion cyclotron emission, this dependence on the frequency might be related to the location of the radiation.

In order to examine the reason for this frequency dependence, a fast sampling of the radiation signal up to several GHz for full power spectrum measurement will be conducted in the 18th experiment campaign in addition to measurement with the existing RF spectrometers.

1) Leem, J., et. al., J. Instrum. 7, C01042 (2012)

2) Yun G., et. al., annual report, 46 (2013).

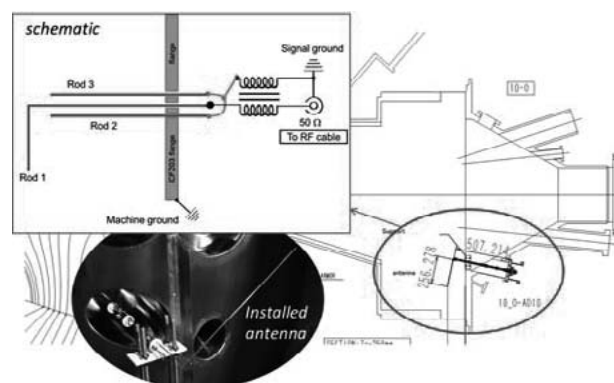

Fig. 1: Dipole antenna installed inside the vessel at the 10-O port.



Fig. 2: The bow-tie antenna installed outside the vacuum vessel

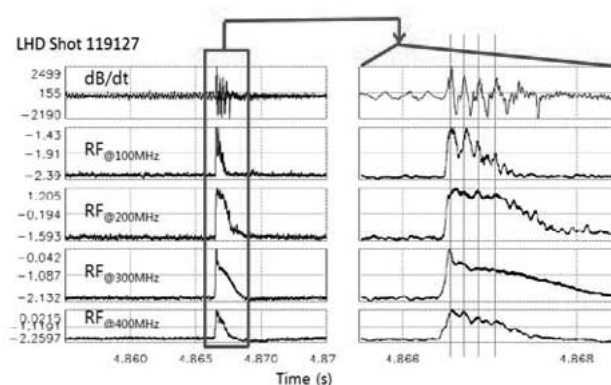

Fig.3 : dB/dt and RF radiations during the EIC. Right figures are expansion of the burst.

3) X.D. Du et. al., annual report, 131 (2013).