

Analysis of the Normal Transition Event of the LHD Helical Coils

Nagato Yanagi, Shinsaku Imagawa, Toshiyuki Mito, Akifumi Iwamoto, Hiroataka Chikaraishi, Shinji Hamaguchi, Arata Nishimura, Takashi Satow, Yukio Nakamura, Sadao Satoh, Osamu Motojima, and the LHD Group
National Institute for Fusion Science, 322-6 Oroshi-cho, Toki, Gifu 509-5292, Japan

Andrew V. Gavrilin
Kurchatov Institute, 123182, Moscow, Russia

Abstract—Normal transitions and a subsequent quench were experienced with the pool-cooled helical coils of the Large Helical Device (LHD) during its excitation test. Although the initiated normal zone once started to recover, a disruptive transverse propagation followed and triggered an emergency discharging program. The cryogenic stability of the composite-type superconductor has been studied by sample experiments as well as by numerical calculations. Due to the rather long magnetic diffusion time constant in the pure aluminum stabilizer, transient stability of the conductor seems to play an important role for driving finite propagation of a normal zone. The cause of the final quench is also discussed from the viewpoint of cooling deterioration due to a possible accumulation of helium bubbles.

I. INTRODUCTION

The construction of the Large Helical Device (LHD) has been successfully completed with a fully superconducting coil system [1], and fusion-relevant plasma experiments are ongoing with a heliotron magnetic configuration that requires no toroidal plasma current [2]. The one pair of two helical coils (H1 and H2) have a major radius of 3.9 m and are pool-cooled with 4.4 K liquid helium in the present Phase I condition. In the Phase II program of LHD, 1.8 K Helium II will be supplied and the maximum stored magnetic energy will reach up to 1.6 GJ with a toroidal magnetic field of 4 T.

Each of the two helical coils consists of three independent blocks, H-I (inner), H-M (middle) and H-O (outer), and the whole windings are contained in thick stainless steel coil-cans. The corresponding blocks of the two coils are connected in series to three individual DC power supplies through six superconducting bus-lines. For quench detection, balance voltages are measured between each corresponding block. For example, the H-I balance voltage is given by subtracting the terminal voltage of the H2-I block from that of the H1-I block in a quench detection circuit.

Manuscript received September 27, 1999.
E-mail: yanagi@LHD.nifs.ac.jp, Phone: +81-572-58-2126, Fax: +81-572-58-2616

During the excitation tests of LHD aiming at a nominal toroidal field of 3 T at 4.4 K, normal transitions occurred at the innermost layers of the helical coils, and a coil quench followed at the toroidal field of 2.75 T. The details of this entire event including the general excitation characteristics of the helical coils are described in [3]. In this paper, the cryogenic stability of the winding conductor is discussed based on sample conductor tests and comparison with numerical calculations for investigating the cause of the normal transition. The final quench event is also examined from the viewpoint of cooling deterioration, based on the experiences obtained with R&D coils.

II. THE NORMAL TRANSITION EVENT

Fig. 1 shows the waveforms of the measured balance voltage signals for the three blocks of the helical coils during the quench event. A transport current of 11.45 kA was being supplied to each block before the emergency discharge. As is inferred from the positive rise of the H-I balance voltage (at $t \approx$

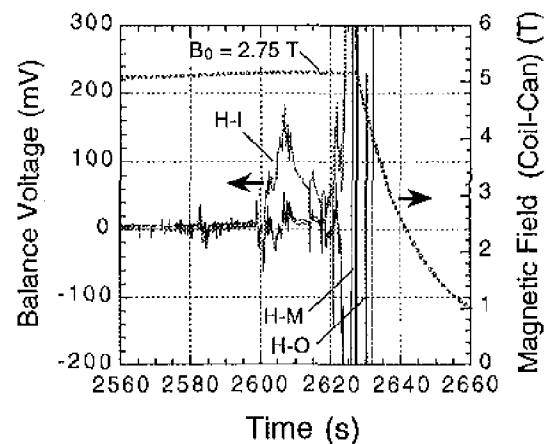

Fig. 1 Waveforms of the balance voltage signals measured for the three blocks of the helical coils, during a quench event at a toroidal field of 2.75 T. Magnetic field measured by a Hall probe on the coil-can is also shown.

2600 s) in Fig. 1, a normal zone was initiated in the H1-I block. According to the normal conducting resistivity of the superconductor obtained by previous sample tests, the initiated normal zone can be estimated to have developed over approximately 15 m and then it started to shrink (at $t \approx 2607$ s). It might be reasonable to consider that a normal zone was initiated at the innermost layer of H1-I block, where the magnetic field becomes the highest. According to the spike signals seen on the balance voltages, the initiation of normal zones seemed to be brought on by mechanical disturbances due to the large electromagnetic force acting on the windings.

Despite the gradual recovering process of the normal zone, sudden and simultaneous increases of the balance voltages occurred for all three blocks (at $t \approx 2621$ s), which finally triggered the quench detectors. Then the emergency discharging process went into action (at $t \approx 2627$ s) as it was programmed to do. Subsequently, the entire superconducting coil system, including the poloidal coils and bus-lines, were safely discharged with a time constant of 20 s, together with the proper action of the cryogenic system [4].

III. STABILITY CHARACTERISTICS OF THE HELICAL COIL SUPERCONDUCTOR

A. Stability Test Results with Conductor Samples

For the pool-cooled helical coil windings, a NbTi/Cu composite-type superconductor is used with a high purity aluminum stabilizer and a copper jacket. One of the key features of this conductor (size: 12.5 mm \times 18 mm, nominal current: 13.0 kA at 6.9 T) is that CuNi is used, instead of conventional copper, as the clad material around the pure aluminum core to reduce the parasitic Hall current generation

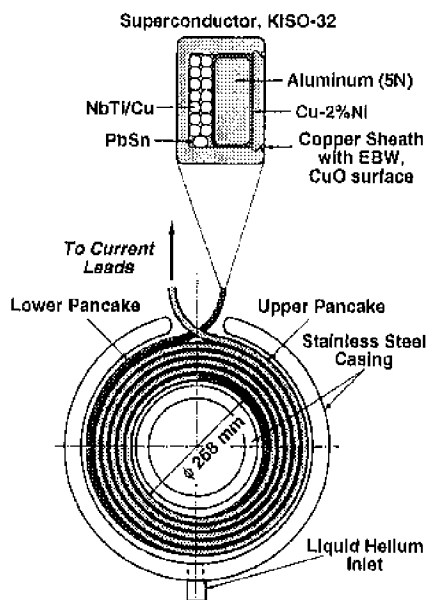

Fig. 2 Schematic drawing of a double pancake coil, HELIUT. The internal structure of the superconductor is also shown.

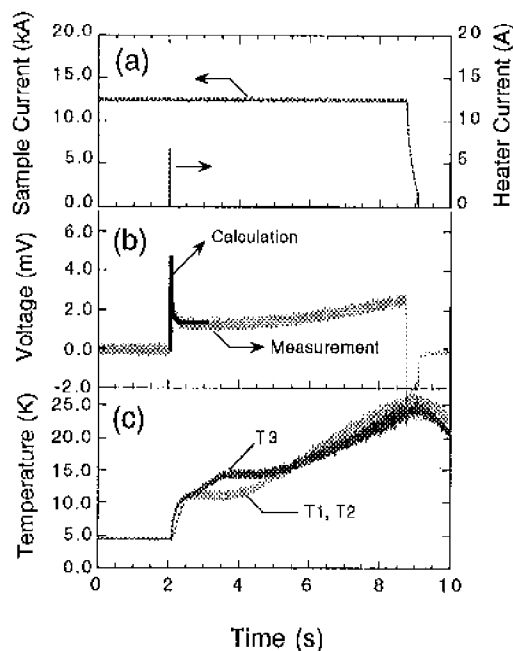

Fig. 3 Typical waveforms of the measured signals on the R&D coil HELIUT during a stability test. (a) Transport current and heater power, (b) a longitudinal voltage at the innermost layer with a 126 mm tap, and (c) conductor surface temperatures. In (b), the thick solid line is given by numerical simulation.

[5, 6] that deteriorates the effective magnetoresistivity of aluminum/copper composites and hence the cryogenic stability or the recovery current of the conductor.

The cryogenic stability of this superconductor has been intensively studied by preparing a number of short samples [7] as well as R&D coils [8]. A short sample consists of two or four straight conductors, each 2 m long and soldered together in series. Fig. 2 illustrates one of the R&D coils, named HELIUT, which has double pancake windings (inner radius: 134 mm, outer radius: 227 mm), each 5 turns, and a total conductor length of 13 m. Both short samples and coil samples have been tested in a superconductor test facility with a 9 T split-coil, 100 kA current leads, and 75 kA DC power supplies. The sample conductors were directly cooled by 4.4 K liquid helium and stability tests were performed using tiny resistive heaters installed on the conductor surface to initiate a normal zone. The recovery currents and stability margins were measured by changing the bias magnetic field.

Fig. 3 shows a typical example of the waveforms of a longitudinal voltage signal as well as temperature signals measured for the R&D coil HELIUT. In this case, the maximum field on the innermost conductor was 6.8 T by adding the self-field generated by the sample coil current of 12.5 kA to the bias field of 6.4 T. As is seen in Fig. 3(b), after the initiation of a normal zone by the heater power, a longitudinal voltage develops with a short-time excess rise at the beginning of the propagation. This peak voltage seems to be brought on by the magnetic diffusion process in the pure aluminum core. A simple one-dimensional analysis gives a

time constant of 84 ms which is fairly close to the measured value of 97 ms determined from the voltage signal.

Fig. 4 shows the dependence of the measured propagation velocity of normal zones on the transport current. Data are taken from some of the short sample tests as well as the HELIUT coil with the magnetic field of 7 T. One important point found in Fig. 4 is that we observe finite propagation of a normal zone even with a transport current lower than the 'cold-end' recovery current. In this region, an initiated normal zone develops over a few meters length within a few seconds time and then it ceases to propagate further and shrinks back to the superconducting state.

B. Comparison with Numerical Analysis

Numerical calculations with sophisticated computer codes have been conducted [9] for solving electromagnetic and thermal processes inside of the present conductor. In the calculation, degradation of the effective resistivity of aluminum/copper composites due to Hall current generation is taken into account with a simple model, and the dynamic current diffusion process into the aluminum core is properly treated. In Fig. 3(b), the longitudinal voltage obtained by the calculation is shown, which gives fairly good agreement with the measured waveform at the initial phase. Based on this good agreement between the two, it was confirmed that the peak voltage can be explained by a current diffusion process into the aluminum core, which transiently reduces the cryogenic stability and hence permits normal zone propagation, even though the transport current is lower than the steady-state 'cold-end' recovery current. This seems to be a similar phenomenon to that observed for the aluminum stabilized conductor developed for a SMES project [10]. The propagation velocity evaluated by the calculation is indicated in Fig. 4. For the measurement data, we see a considerable difference in the propagation velocity depending on the propagation direction defined as the up- or downstream side of the transport current. This seems to be related to the Hall voltage generation, however, a satisfactory explanation has not yet been made. The calculated propagation velocity lies

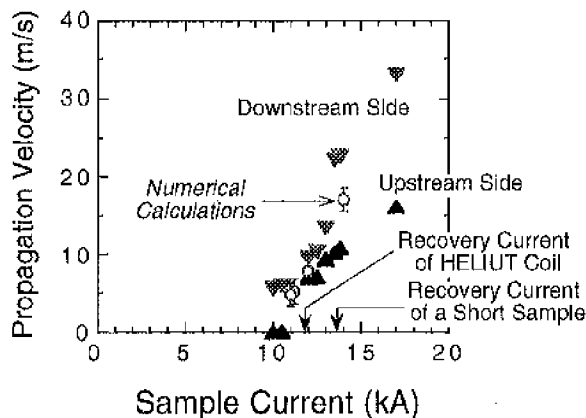

Fig. 4 Propagation velocity of normal zones as a function of transport current, measured for short samples and a coil sample. The dashed line is given by numerical analysis.

between the two measured lines. The numerical calculation confirms that a finite propagation is possible even at a transport current of 9 kA.

IV. DISCUSSION

During the LHD excitation tests, normal transitions in the H-I blocks have been observed five times, including the most severe one shown in Fig. 1. In other cases, the initiated normal zones lasted only for a few seconds and recovered, and thus there has been no other quench. The important point is that even for the quench case, the normal zone initially showed a recovering process. These observations seem to be exactly consistent with our understanding of transient instability, which was confirmed with sample tests.

The cause of triggering the final disruptive transverse propagation that led to the quench of the H1 coil could be explained by possible deterioration of cooling conditions due to an accumulation of helium bubbles. As is described in [3], from the temperature data of the stainless steel coil-cans, it is inferred that the quenching process started at one cross-section of the H1 coil, where it is located below the equatorial plane of the torus. At this location, the generated helium bubbles may have accumulated around the innermost layer of the windings where they are positioned at the top roof section in the coil-can. It was estimated that the cooling rate should deteriorate drastically within a few seconds in the tight channels formed by windings and spacers.

This scenario seems to be supported by the experimental observation of a similar quench event that we had already experienced with a model superconducting helical coil named TOKI-HB [11] which was tested through the R&D programs before constructing LHD. TOKI-HB had one helical coil (major radius: 0.8 m) with a helical pitch number of 3, which was about 1/5 the size of the LHD helical coils. The composite-type NbTi superconductor (size: 8 mm × 16 mm, nominal current: 8.93 kA at 3.0 T) used for the windings had a similar internal structure to that used for the LHD helical coils, but with a conventional copper-clad aluminum stabilizer. A resistive heater of 0.9 m long was installed inside of the conductor along the aluminum stabilizer at the innermost layer of the windings. A number of voltage taps were attached on the conductor surface to pick up a normal zone development around the heater area. Fig. 5 shows the stability test results obtained at a transport current of 9.0 kA. As is seen in Fig. 5(a), for the case with an input energy of 280 W × 1 s, the initiated normal zone completely recovered in about 6 s after the termination of the heater energy. On the other hand, when the energy input was increased to 280 W × 2 s (Fig. 5(b)), the initiated normal zone could not recover and about 9 s after the heater termination, the neighboring conductors turned into normal conducting. The important point is that the recovery current of the conductor should be still higher than this transport current as we see no longitudinal propagation of the initiated normal zone beyond the heater installed region. However, what had followed was a transverse (turn-to-turn and layer-to-layer) propagation of the normal zone, as is seen by the voltage development on the neighboring turns. This might be explained when we take

deterioration of the cooling condition into account. Since the winding structure of the TOKI-HB helical coil was basically similar to that applied for the LHD helical coils, accumulation of helium bubbles in the interior of the coil-can could also be possible, especially at the position where the helical coil is located below the equatorial plane.

Another example for supporting the scenario of cooling deterioration is found in the test results of the double pancake R&D coil, HELIUT. Fig. 3(c) shows the temperature development of the innermost conductor of this coil during a stability test. Cernox sensors were attached on the conductor surface; T1 and T2 were located above the equatorial plane, whereas T3 were at below the equatorial plane. As is seen in Fig. 3(c), although T1 and T2 showed temporary decreases, T3 continuously increased, which might have led to the full quench of the coil at the end. This phenomenon might also be explained by the deterioration of cooling conditions, especially at the lower part of the coil where it should have an easier condition for accumulating helium bubbles between tight cooling channels in a stainless steel coil-can. On the contrary, another R&D coil without a coil-can showed significantly higher recovery currents [8].

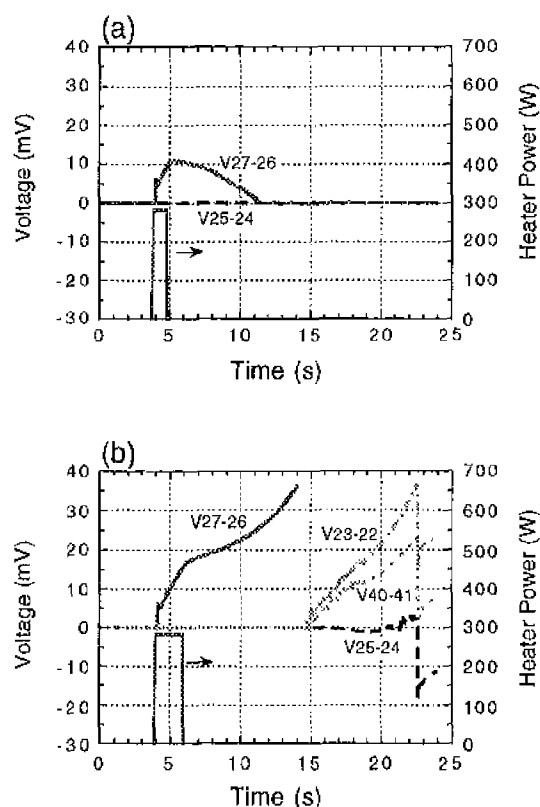

Fig. 5 Voltage signals measured in the R&D helical coil TOKI-HB. (a) A recovery case of a normal zone and (b) a quench case. The voltage tap V27-26 covers the heater installed region at the innermost layer of the winding and V25-24 is the neighboring tap on the same turn. Other taps are on different turns; V23-22 is on the next turn in the same layer and V40-41 on the next layer.

V. CONCLUSION

Normal transitions and a subsequent quench were experienced by the pool-cooled helical coils of LHD. Stability tests with short samples and R&D coils confirmed that the conductor could become transiently unstable even though the transport current is lower than the 'cold-end' recovery current. Numerical calculations explained that this is due to the relatively long diffusion time constant in the aluminum core. Although the initiated normal zone started to recover, a disruptive transverse propagation seemed to be triggered for all the blocks of the helical coil, which might be caused by the deterioration of cooling condition with an accumulation of helium bubbles. This scenario could be supported by the experimental results obtained with an R&D helical coil as well as by a double pancake coil, both with stainless steel coil-cans. At present, the helical coils steadily supply a toroidal magnetic field of up to 2.75 T for confining high temperature plasmas in LHD.

ACKNOWLEDGMENTS

The authors wish to thank all the staff in NIFS for helping them carry out the LHD excitation tests as well as R&D experiments. They greatly appreciate the tremendous effort done by the staff of Hitachi Ltd. and Hitachi Cable Ltd. in developing and fabricating the superconductor, its short samples, the R&D coils, and the helical coils of LHD.

REFERENCES

- [1] O. Motojima, K. Akaishi, K. Fujii, et al., "Physics and engineering design studies on the Large Helical Device", *Fusion Eng. Des.* **20** (1993) pp.3-14.
- [2] A. Hyoshi, S. Imagawa, the LHD Group, "Design, construction and the first operation of LHD", 20th Symposium on Fusion Tech., (Marseille, 1998).
- [3] S. Imagawa, N. Yanagi, H. Chikaraishi, et al., "Results of the first excitation of helical coils of the Large Helical Device", this conference.
- [4] T. Mito, R. Mackawa, A. Iwamoto, et al., "Performance of the LHD cryogenic system during cooling and excitation tests", this conference.
- [5] P.W. Fekels, N.C. Iyer, A. Patterson, et al., "Magneto-resistance: the Hall effect in composite aluminum cryoconductors", *Cryogenics* **29** (1989) pp.748-752.
- [6] H. Kaneko, N. Yanagi, "Enhancement of magneto-resistance due to Hall current in aluminum-copper composite", *Cryogenics* **32** (1992) pp.1114-1120.
- [7] N. Yanagi, T. Mito, S. Imagawa, et al., "Development, fabrication, testing and joints of aluminum stabilized superconductors for the helical coils of LHD", *Proc IEC16/ICMC (Kita-Kyushu 1996)*, pp.751-754.
- [8] V.S. Vysetsky, N. Yanagi, Yu.A. Ilyin, et al., "Temperature and electric field distribution measurement inside of the LHD helical conductor", this conference.
- [9] A.V. Gavrilin, N. Yanagi, S. Satoh, O. Motojima, "Computer simulation of normal zone propagation in the LHD helical coils", *Advances in Supercond.* **XI** (1999) pp.1447-1450.
- [10] J.M. Pfotenhauer, M.K. Abdelsalam, F. Bodker, et al., "Test results from SMES proof of principle experiment", *IEEE Trans Magn.* **27** (1991) pp.1704-1707.
- [11] T. Senba, S. Suzuki, T. Masumoto, et al., "Design and construction of the helical R&D coil (TOKI-HB)", *Fusion Eng. Des.* **20** (1993) pp.195-200.