

1972

The base-catalyzed hydrolysis of the hydrogen phthalate ester of 4-bromo-4'-nitrobenzhydrol : An oxygen-18 exchange study. Pyrolysis of neopentyl-type xanthates. Synthesis of some sulphonyl chlorides as precursors for stable sulphenes.

Bing-Kou. Tang  
*University of Windsor*

Follow this and additional works at: <http://scholar.uwindsor.ca/etd>

---

### Recommended Citation

Tang, Bing-Kou., "The base-catalyzed hydrolysis of the hydrogen phthalate ester of 4-bromo-4'-nitrobenzhydrol : An oxygen-18 exchange study. Pyrolysis of neopentyl-type xanthates. Synthesis of some sulphonyl chlorides as precursors for stable sulphenes." (1972). *Electronic Theses and Dissertations*. Paper 3774.

This online database contains the full-text of PhD dissertations and Masters' theses of University of Windsor students from 1954 forward. These documents are made available for personal study and research purposes only, in accordance with the Canadian Copyright Act and the Creative Commons license—CC BY-NC-ND (Attribution, Non-Commercial, No Derivative Works). Under this license, works must always be attributed to the copyright holder (original author), cannot be used for any commercial purposes, and may not be altered. Any other use would require the permission of the copyright holder. Students may inquire about withdrawing their dissertation and/or thesis from this database. For additional inquiries, please contact the repository administrator via email ([scholarship@uwindsor.ca](mailto:scholarship@uwindsor.ca)) or by telephone at 519-253-3000ext. 3208.



PART I

THE BASE-CATALYZED HYDROLYSIS OF THE HYDROGEN PHTHALATE ESTER  
OF 4-BROMO-4'-NITROBENZHYDROL - AN  $^{18}\text{O}$  EXCHANGE STUDY

PART II

PYROLYSIS OF NEOPENTYL-TYPE XANTHATES

PART III

SYNTHESIS OF SOME SULPHONYL CHLORIDES  
AS PRECURSORS FOR STABLE SULPHENES

BY

TANG BING-KOU

A Dissertation

Submitted to the Faculty of Graduate Studies through the  
Department of Chemistry in Partial Fulfillment  
of the Requirements for the Degree of  
Doctor of Philosophy at the  
University of Windsor

Windsor, Ontario

1972

©Bing-Kou Tang 1972

## ABSTRACT

### PART I

Racemic 4-bromo-4'-nitrobenzhydryl hydrogen phthalate was hydrolyzed with  $^{18}\text{O}$  enriched sodium hydroxide solution. Analysis by mass spectrometry showed that the benzhydrol obtained from this reaction was not enriched by  $^{18}\text{O}$  over the natural abundance while the phthalic acid contained 99.8% of the theoretical amount required. This supported the conclusions drawn from the kinetics and stereochemical evidence obtained previously in this laboratory, that the above hydrolysis occurs by a normal  $\text{B}_{\text{AC}}2$  mechanism and that the  $\text{B}_{\text{AL}}1$  and  $\text{B}_{\text{AL}}2$  mechanisms are not operative.

### PART II

A study of the pyrolysis of a series of neopentyl-type xanthate esters was carried out at  $250^\circ\text{C}$ . The S-methyl neopentyl xanthate was found to yield only the corresponding dithiolcarbonate. When the methyl groups on the beta-carbon atom were replaced successively by the phenyl group, olefinic products resulting from prior Wagner-Meerwein rearrangement were obtained as well as the corresponding dithiolcarbonates. In the case of S-methyl 2,2,2-triphenylethyl xanthate, only triphenylethylene was obtained and in almost quantitative yield.

From a study of the kinetics on the series of xanthates it is concluded that neighbouring group participation plays an important role in the removal of the xanthate moiety since the rate of decomposition increased with increasing phenyl substitution on the beta-carbon atom. Phenyl participation was also supported by a study of comparative rates of decomposition of the 2-phenyl, the 2-para-tolyl- and the 2-para-bromophenyl-2,2-dimethylethyl xanthate esters. The kinetics and product distribution studies showed that olefin and dithiolcarbonate formation were two competing processes.

### PART III

Sulphenes are generally accepted as intermediates in the reaction of trialkylamines with aliphatic sulphonyl chlorides and in the reaction of sulphur dioxide with diazoalkanes. Attempts to prepare stable sulphenes have not been successful thus far. In the belief that the relation between structure and stability of sulphene would very likely obey the same rules as other ylides, three model stable sulphenes have been proposed: diphenylmethanesulphene, 3,5-di-tert-butyl-4-quinoidsulphene and flaviansulphene. Attempts were made to prepare the corresponding sulphonyl chlorides as precursors for the stable sulphenes.

## ACKNOWLEDGEMENTS

I would like to express my sincere appreciation to both Dr. K. G. Rutherford and Dr. K. M. Lam for their guidance and direction during the course of this work. In addition, I wish to thank many of my colleagues at the University of Windsor who have rendered assistance in various ways.

TABLES OF CONTENTS

	Page
ABSTRACT .....	ii
ACKNOWLEDGEMENTS .....	iv
LIST OF TABLES .....	vii
LIST OF FIGURES .....	viii

PART I

Chapter		
I	INTRODUCTION .....	1
II	RESULTS AND DISCUSSION .....	5
III	EXPERIMENTAL .....	7
	REFERENCES .....	9

PART II

I	INTRODUCTION .....	10
II	RESULTS AND DISCUSSION .....	21
	Synthesis of Xanthates .....	21
	Product Studies .....	24
	Kinetic Studies .....	29
	Wagner-Meerwein Rearrangement Leading to Olefin Formation .....	40
	Dithiolcarbonate Formation .....	46
	Summary and Conclusions .....	47



III	EXPERIMENTAL .....	48
	REFERENCES .....	71

PART III

I	INTRODUCTION .....	74
II	RESULTS AND DISCUSSION .....	85
	Attempted Synthesis of Diphenylmethanesulphonyl Chloride .....	85
	Attempted Synthesis of the Sulphonyl Chloride of Flavianic Acid .....	87
	Synthesis of 3,5-Di-tert-butyl-4-hydroxy- benzenesulphonyl Chloride .....	89
III	EXPERIMENTAL .....	91
	REFERENCES .....	96
	VITA AUCTORIS .....	98

LIST OF TABLES

Table		Page
PART II		
I	Pyrolysis of Xanthates Showing Both <u>trans-</u> and <u>cis-</u> Elimination Products .....	14
II	Xanthate Derivative .....	23
III	Pyrolysis of Neopentyl-type Xanthate at 250°C ...	25
IV	Pyrolysis of Neopentyl-type Xanthate at 250°C ...	36
V	Rates of Acetolysis of Neopentyl-type Brosylates ( $k_g$ ) at 75°C and Calculated Rates of Olefin Formation in the Pyrolysis of Neopentyl-type Xanthates ( $k_0$ ) at 250°C .....	41
VI	Pyrolysis of S-Methyl Neopentyl Xanthate at 250 ± 1°C .....	62
VII	Pyrolysis of S-Methyl Neophyl Xanthate at 250 ± 1°C .....	63
VIII	Pyrolysis of S-Methyl p-Bromoneophyl Xanthate at 250 ± 1°C .....	64
IX	Pyrolysis of S-Methyl p-Methylneophyl Xanthate at 250 ± 1°C .....	65
X	Pyrolysis of S-Methyl 2,2-Diphenylpropyl Xanthate at 250 ± 1°C .....	66
XI	Pyrolysis of S-Methyl 2,2,2-Triphenylethyl Xanthate at 174 ± 1°C .....	67
XII	Pyrolysis of S-Methyl 2,2,2-Triphenylethyl Xanthate at 185 ± 1°C .....	68
XIII	Pyrolysis of S-Methyl 2,2,2-Triphenylethyl Xanthate at 200 ± 1°C .....	69
XIV	Pyrolysis of S-Methyl 2,2,2-Triphenylethyl Xanthate at 220 ± 1°C .....	70

## LIST OF FIGURES

Figure		Page
PART I		
1	Methanolysis of Optically Active 4-Methyl-benzhydryl Hydrogen Phthalate .....	2
2	Reaction Paths Leading to Acyl-oxygen Fission in the Methoxide Ion Catalyzed Methanolysis of 4-Bromo-4'-nitrobenzhydryl Hydrogen Phthalate .....	4
3	Synthesis of 4-Bromo-4'-nitrobenzhydryl Hydrogen Phthalate Ester .....	5
4	Probable Distribution of $^{18}\text{O}$ Among the Hydrolyzed Products .....	5
PART II		
1	The Chugaev Reaction .....	10
2	Proposed Mechanism for the Pyrolysis of Xanthate Esters .....	11
3	Decomposition of S-Methyl Xanthate Ester of Threo- and Erythro-3-phenyl-2-butanol .....	12
4	Pyrolysis of the S-Methyl Xanthate Ester of 2-Octanol and Trifluoromethyl-n-hexyl-carbinol .....	13
5	A Proposed Carbonium Ion Intermediate in the Pyrolysis of the S-Methyl Xanthate Ester of <u>Cis</u> -2-methylcyclohexanol .....	15
6	A Proposed Homolytic Cleavage of the S-p-Bromophenacyl Xanthate Esters of Some Primary Alcohols .....	16
7	Pyrolysis of S-Methyl <u>Cis</u> -2-p-tolyl-sulphonylcyclohexyl Xanthate .....	16

8	BBT Procedure to Convert Xanthate to Olefins .....	18
9	A Cyclic Transition State Proposed for the Dithiolcarbonate Formation from Pyrolysis of S-Methyl 1-Cyclopropylethyl Xanthate .....	18
10	A Proposed Ion-pair Transition State for the Dithiolcarbonate Formation from the Pyrolysis of S-Methyl <u>Trans</u> -2-dimethylaminocyclohexyl Xanthate .....	19
11	Pyrolysis of Some Neopentyl Xanthate Esters .....	19
12	Synthesis of S-Methyl p-Bromoneophyl Xanthate .....	21
13	Identification of the S-Methyl Neophyl Dithiolcarbonate.....	26
14	The Probable Courses of Reaction for the Pyrolysis of Neopentyl-type Xanthate .....	28
15	The First Order Kinetic Plots of the Disap- pearance of S-Methyl Neopentyl Xanthate [X] and the formation of Neopentyl Dithiolcarbonate [D] at 250°C on a Semi-logarithmic Paper .....	31
16	The First Order Kinetic Plots of the Disap- pearance of S-Methyl p-Bromoneophyl, Neophyl and p-Methylneophyl Xanthates at 250°C on a Semi-logarithmic Paper .....	32
17	The First Order Kinetic Plots of the Disap- pearance of S-Methyl 2,2-Diphenylpropyl Xanthate at 250°C on a Semi-logarithmic Paper .....	33
18	The First Order Kinetic Plots of the Disap- pearance of S-Methyl 2,2,2-Triphenylethyl Xanthates at Four Different Temperatures on a Semi-logarithmic Paper.....	34
19	The Logarithm of Rate Constants Obtained from the Pyrolysis of S-Methyl 2,2,2-Triphenylethyl Xanthate was plotted Against the Reciprocal of the Absolute Temperature .....	35
20	The Rate of Disappearance of S-Methyl p-Bromo- neophyl and Neophyl Xanthates Against the Rate of Formation of the Corresponding Dithiolcarbonates ..	39
21	The Linear Free Energy Plot of the Rates of Pyrolysis of Neopentyl-type Xanthates and the Rates of Acetolysis of Neopentyl-type Brosylates .....	42
22	Proposed Transition State for the Olefin (s) Formation Process .....	43

23	Plot of logk for the Pyrolysis of S-Methyl para-Substituted Neophyl Xanthates at 250°C Against $\sigma^+$ Values .....	44
24	The Proposed Transition State of the Pyrolysis of S-Methyl Diphenylpropyl Xanthate .....	45
25	The Possible Transition State of the Xanthate- Dithiolcarbonate Rearrangement .....	46
26	A N-tube for Pyrolysis .....	55

### PART III

1	Canonical Structures of Sulphenes .....	74
2	Ylide-type Reactions of Sulphene Intermediates ...	75
3	1,2-Addition Reactions of Sulphene Intermediates .....	76
4	Formation of Mesylsulphene Adduct .....	77
5	A Proposed 1,3-Addition Reaction of a Sulphene Intermediate. ....	77
6	A Proposed Carbonyl-like Reaction of a Sulphene Intermediate .....	78
7	Generation of a Sulphene Intermediate with Triethylamine .....	78
8	Generation of a Sulphene Intermediate by the Reaction of Diphenyldiazomethane and Sulphur Dioxide .....	80
9	Generation of a Sulphene Intermediate by Irradiation of a Sultone .....	80
10	Generation of a Vinylsulphene Intermediate from the Pyrolysis of a Thiet 1,1-Dioxide .....	81

11	Generation of a Sulphene Intermediate by Chlorinolysis of 2 H-1,2,3-benzothiadiazine 1,1-Dioxide .....	81
12	Generation of a Sulphene Intermediate from the Reaction of Sodium Hydride with 1-Chloroethanesulphinic Acid .....	82
13	A Proposed $\alpha$ -Carbalkoxyl Stabilized Sulphene.....	82
14	Proposed 9-Fluorensulphene .....	83
15	Cyclo-addition Reaction of 9-Fluorensulphene Intermediate with N,N-Dimethyl-1-isobutenylamine .....	83
16	Proposed Stable Sulphenes .....	85
17	Synthesis of 9-Fluorensulphonyl Chloride .....	86
18	Proposed Route to Diphenylmethanesulphonyl Chloride .....	86
19	Proposed Structure of Flaviansulphene Dimer .....	88
20	Proposed Reaction of Flavianic Acid with Phosphorus Pentachloride .....	88
21	Preparation of 3,5-Dimethyl-4-hydroxybenzenesulphonyl Chloride .....	89
22	Preparation of 3,5-Di-tert-butyl-4-hydroxybenzenesulphonyl Chloride .....	90

## PART I

# THE BASE-CATALYZED HYDROLYSIS OF THE HYDROGEN PHTHALATE ESTER OF 4-BROMO-4'-NITROBENZHYDROL - AN <sup>18</sup>O EXCHANGE STUDY

## CHAPTER I

### INTRODUCTION

There are four possible mechanisms which can be postulated for the base-catalyzed solvolysis of hydrogen phthalate esters: (1) alkyl-oxygen fission involving ionization ( $B_{AL}1$ ); (2) alkyl-oxygen fission involving nucleophilic displacement ( $B_{AL}2$ ); (3) acyl-oxygen fission involving ortho-carboxylate anion participation ( $B_{AC}1$ ); (4) acyl-oxygen fission involving normal ester solvolysis ( $B_{AC}2$ ).

The  $B_{AL}1$  mechanism has been observed to be quite general when the 4-position of one of the benzene rings of the benzhydryl group is substituted by electron releasing groups. Thus Davies<sup>1</sup> showed that when optically active 4-methylbenzhydryl hydrogen phthalate was treated with boiling methanol, a 20% yield of racemic 4-methylbenzhydryl methyl ether was obtained along with 72% of the original ester (Fig. 1). Similarly, optically active 4-alkylthio- and 4-dialkylamino-substituted benzhydryl esters lead to racemized products on solvolysis.

The  $B_{AL}2$  mechanism has not been observed in the solvolysis of hydrogen phthalate esters and is indeed extremely rare in the case of the base-catalyzed solvolysis of other carboxylic

esters.

The  $B_{AC1}$  mechanism was first observed by Bender<sup>4</sup> who showed that the ortho-carboxylate anion has an intramolecular catalytic effect on the hydrolysis of methyl hydrogen phthalate. More recently, Thanassi and Bruice<sup>5</sup> have shown ortho-carboxylate anion participation in the hydrolysis of phenyl- and 2', 2', 2'-trifluoroethyl hydrogen phthalate. Such was not the case however with poor leaving groups. The authors concluded that hydrogen phthalate esters with good leaving groups hydrolyze with catalysis of the ortho-carboxylate anion, while those with poor leaving groups (e.g. methoxy and 2'-chloroethoxy) hydrolyze with catalysis of the neutral carboxylic acid function.

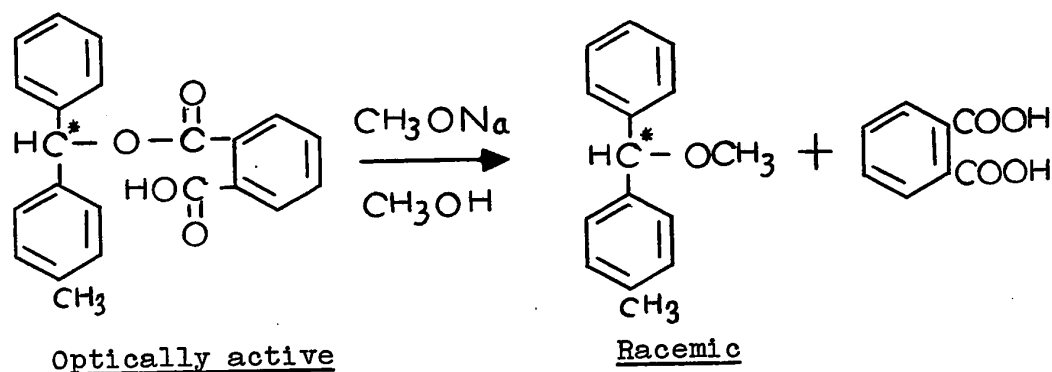

Fig. 1. Methanolysis of Optically Active 4-Methylbenzhydryl Hydrogen Phthalate.

Puckowski and Ross<sup>6</sup> reported that optically active 2-, 3-, and 4-nitro, 3, 5-dinitro, and 3-bromobenzhydryl hydrogen phthalate esters yielded optically active benzhydrols on treatment with aqueous sodium hydroxide or with aqueous sodium carbonate (presumably by the  $B_{AC1}$  or  $B_{AC2}$  mechanism). In view



of the work of Thanassi and Bruice, one might expect that the nitro-substituted benzhydryl hydrogen phthalates would undergo solvolysis via the  $B_{AC}1$  mechanism since nitro-substituted benzhydroxy moieties would be classified as good leaving groups.

Recently, a study<sup>7</sup> was carried out in our laboratory on the methanolysis and hydrolysis of 4-bromo-4'-nitrobenzhydryl hydrogen phthalate. The presence of the nitro group and the bromine atom should render the benzhydroxy moiety a good leaving group and thus the  $B_{AC}1$  mechanism should be observed at least to some extent. Figure 2 shows the two accepted mechanisms for these solvolyses involving acyl-oxygen fission ( $B_{AC}1$  and  $B_{AC}2$ ).

The methoxide ion catalyzed methanolysis of the ester exhibited second order kinetics (first order in methoxide ion and first order in carboxylate ion) and retention of configuration about the asymmetric carbon atom was observed. No 4-bromo-4'-nitrobenzhydrylmethyl ether was observed. Thus the  $B_{AL}1$ ,  $B_{AL}2$  and  $B_{AC}1$  mechanisms were eliminated leaving only the  $B_{AC}2$  mechanism as the one operative in this system. Similarly second order kinetics were observed for the hydroxide ion catalyzed hydrolysis and again retention of configuration was observed about the asymmetric carbon atom. Again it was concluded that normal ester hydrolysis occurred ( $B_{AC}2$ ).

In order to eliminate any possibility of nucleophilic displacement by hydroxide ion ( $B_{AL}2$  mechanism) which could account for the second order kinetics observed, it was decided

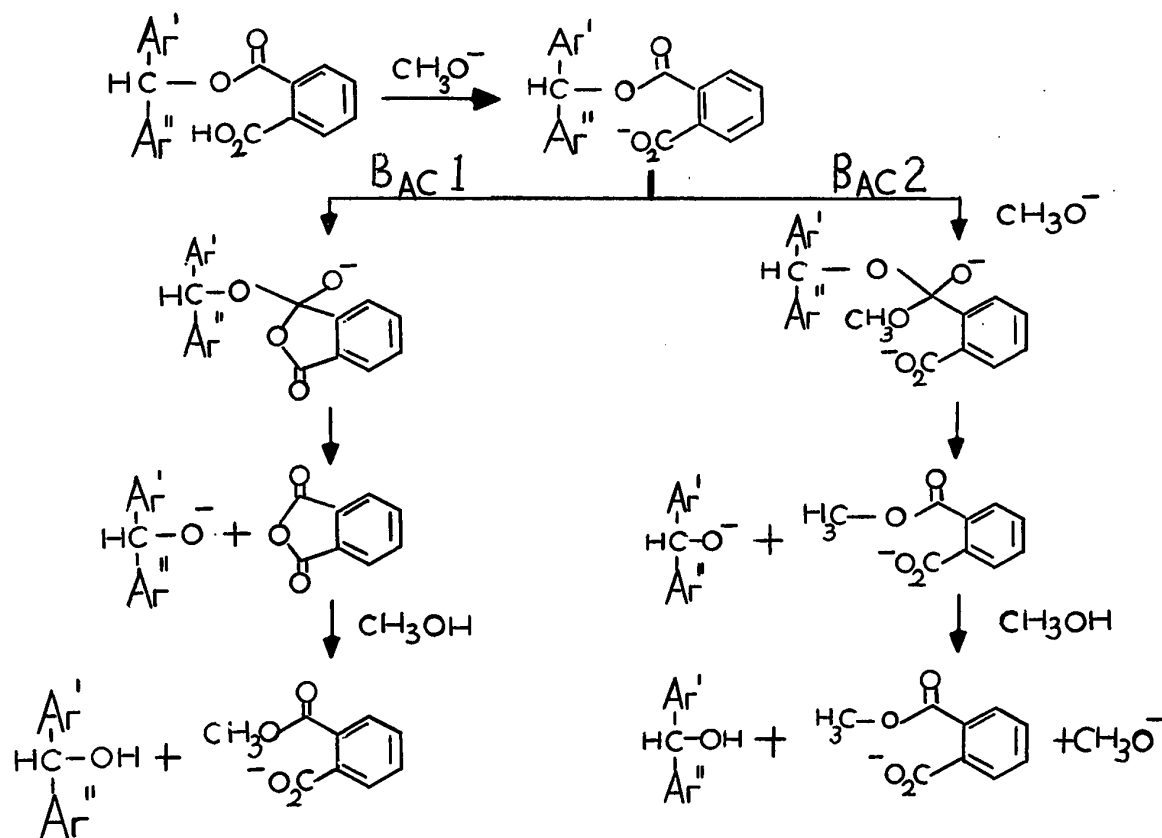

Fig. 2. Reaction Paths Leading to Acyl-oxygen Fission in the Methoxide Ion Catalyzed Methanolysis of 4-Bromo-4'-nitrobenzhydryl Hydrogen Phthalate.

to conduct an  $^{18}\text{O}$  isotope study on the base-catalyzed hydrolysis of the 4-bromo-4'-nitrobenzhydryl hydrogen phthalate ester. The absence of  $^{18}\text{O}$  in the 4-bromo-4'-nitrobenzhydryl would eliminate the  $\text{B}_{\text{AL}}2$  pathway for hydrolysis.

CHAPTER IIRESULTS AND DISCUSSION

The 4-bromo-4'-nitrobenzhydryl hydrogen phthalate ester was synthesized by the following route (Fig. 3).

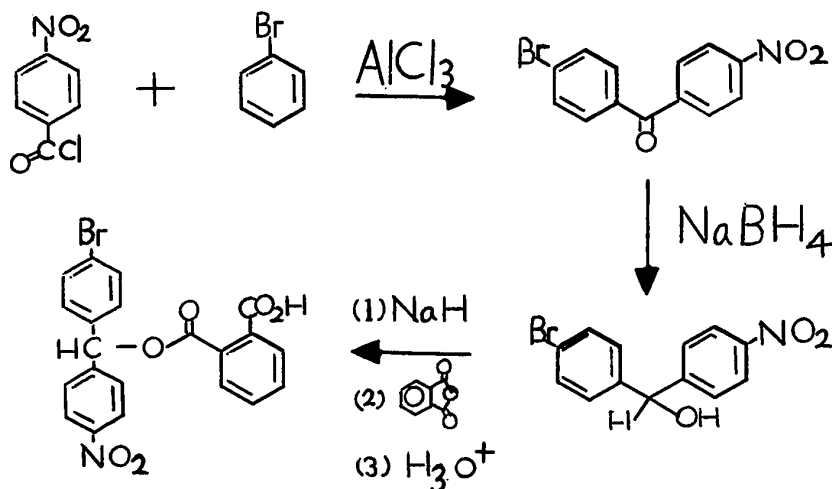

Fig. 3. Synthesis of 4-Bromo-4'-nitrobenzhydryl Hydrogen Phthalate Ester.

In the base-catalyzed hydrolysis of this ester, cleavage may occur at the acyl-oxygen bond or at the alkyl-oxygen bond (Fig. 4).

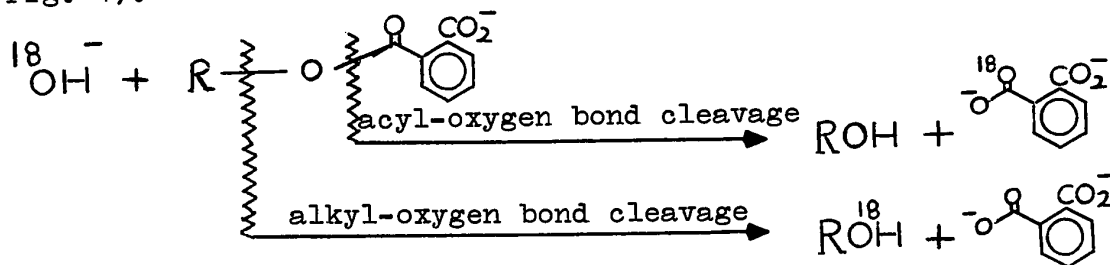

Fig. 4. Probable Distribution of  $^{18}\text{O}$  Among the Hydrolyzed Products.

In the first case, all the  $^{18}\text{O}$  would be incorporated in the phthalic acid while no  $^{18}\text{O}$  would be found in the benzhydrol if hydrolysis were carried out using  $^{18}\text{O}$  enriched aqueous sodium hydroxide solution. In the second case, all the  $^{18}\text{O}$  would be incorporated in the benzhydrol while no  $^{18}\text{O}$  would be found in the phthalic acid. Thus the site of cleavage could be deduced from the distribution of  $^{18}\text{O}$  among the hydrolyzed products.

After the sodium hydroxide catalyzed hydrolysis of the 4-bromo-4'-nitrobenzhydryl hydrogen phthalate ester in  $^{18}\text{O}$  enriched water, the benzhydrol obtained was analyzed by mass spectrometry and found not to be enriched in  $^{18}\text{O}$  over the natural abundance while the phthalic acid contained 99.8% of the theoretical amount of  $^{18}\text{O}$  enrichment. These results are consistent with those expected from acyl-oxygen cleavage during the base-catalyzed hydrolysis of this ester and they exclude any involvement of alkyl-oxygen bond fission. Therefore, the conclusion drawn from the kinetic and stereochemical evidence obtained previously in this laboratory that the base-catalyzed hydrolysis occurs by a normal  $\text{B}_{\text{AC}}2$  mechanism is further confirmed by the results of this study. In addition, this conclusion casts some doubt on the generalization of Thanassi and Bruice that hydrogen phthalate esters with good leaving groups hydrolyze with catalysis of the ortho-carboxylate anion. Thus, it would seem that one also has to consider the possibility of base-catalyzed hydrolysis via the  $\text{B}_{\text{AC}}2$  route as well as by the  $\text{B}_{\text{AC}}1$  pathway involving the ortho-carboxylate anion.

CHAPTER IIIEXPERIMENTALSynthesis of 4-Bromo-4'-nitrobenzhydryl Hydrogen Phthalate. -

The ester was synthesized according to the method of Mamer<sup>7</sup> from phthalic anhydride (10.6 g, 0.72 mole), sodium hydride (3.5 g, 0.72 mole) and 4-bromo-4'-nitrobenzhydrol (22 g, 0.72 mole). Recrystallization of the crude product from an acetone-water solvent pair yielded pale yellow crystals of pure 4-bromo-4'-nitrobenzhydryl hydrogen phthalate (6 g, 80%): mp 184-185°. No depression was observed on admixture with an authentic sample of the compound. The ir bands were identical to those previously recorded.

Base-catalyzed Hydrolysis of 4-Bromo-4'-nitrobenzhydryl Hydrogen Phthalate Ester Using <sup>18</sup>O Enriched Aqueous Sodium Hydroxide

Solution. - Hydrolysis of the hydrogen phthalate ester was carried out in a 10 ml conical flask at 25°. A solution of 4-bromo-4'-nitrobenzhydryl hydrogen phthalate (1 g, 2.2 mmole) in 1 ml of tetrahydrofuran was mixed with an <sup>18</sup>O enriched aqueous sodium hydroxide solution (0.2 g, 5.0 mmole sodium hydroxide in 1 ml 20% <sup>18</sup>O enriched water). After stirring for 14 h, the tetrahydrofuran was removed using a stream of nitrogen and the resultant aqueous mixture was filtered. The yellow solid obtained was washed twice with water and air-dried yielding 4-bromo-4'-nitrobenzhydrol (0.67 g, 99%):

mp 158-160° (lit.<sup>7</sup> mp 160-161°). The ir bands corresponded with an authentic sample of 4-bromo-4'-nitrobenzhydrol. The filtrate was acidified with 6 N hydrochloric acid, filtered and refrigerated overnight. Crystals of pure phthalic acid were formed (0.3 g). The ir bands corresponded with an authentic sample of phthalic acid. The 4-bromo-4'-nitrobenzhydrol was found by mass spectrometry\* not to be enriched in <sup>18</sup>O over natural abundance while the phthalic acid contained 4.58 % <sup>18</sup>O enrichment (99.8% of the theoretically required amount).

---

\* Limiting sensitivity  $\frac{^{18}\text{O}}{(^{18}\text{O} + ^{16}\text{O})} < 0.05\%$ . Analysis was performed by Morgan and Schaffer Corp. Montreal, Quebec.

References

1. A. G. Davies, J. Chem. Soc., 3473 (1954).
2. M. P. Balfe, R. E. Darby, and J. Kenyon, J. Chem. Soc., 382 (1951).
3. M. P. Balfe, J. Chem. Soc., 790 (1952).
4. M. L. Bender, F. Cloupek, and M. Neveu, J. Amer. Chem. Soc., 80, 5384 (1958).
5. J. W. Thanassi and T. C. Bruice, J. Amer. Chem. Soc., 88, 747 (1966).
6. R. T. Puckowski and W. A. Ross, J. Chem. Soc., 3555 (1959).
7. K. G. Rutherford, O. A. Mamer, and B. K. Tang, Can. J. Chem., 47, 1487 (1969).

PART IIPYROLYSIS OF NEOPENTYL-TYPE XANTHATESCHAPTER IINTRODUCTION

The Chugaev reaction<sup>1</sup> is defined as the formation of olefin (s) by the thermal decomposition of the xanthate ester of an alcohol (Fig. 1).

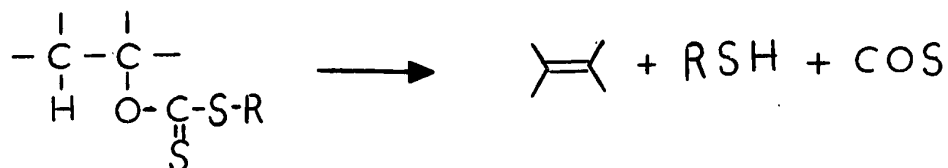

R = Alkyl

Fig. 1. The Chugaev Reaction.

By far, the most commonly used xanthates have been the methyl derivatives (R=CH<sub>3</sub>). From the synthetic point of view, the reaction is simple to carry out and problems in the work-up of the reaction mixture are seldom encountered. Like other pyrolytic reactions, the Chugaev reaction is virtually free from rearrangements unlike the acid-catalyzed dehydration of an alcohol. The Chugaev reaction<sup>1,2</sup> has been used more often than most other pyrolytic elimination reactions for the synthesis of olefins because lower temperatures are usually involved (<200°) and no recycling of reactant is required. For example, the pyrolysis of acetates usually involves temperatures of 350-500° and one usually must recycle unpyrolysed ester especially



in the case of primary and secondary systems in order to obtain appreciable yield of olefins.

The mechanism of xanthate decomposition has been generally agreed to proceed through a concerted six-membered cyclic transition state involving a cis-beta-hydrogen and the thione sulphur atom, as shown in Figure 2.

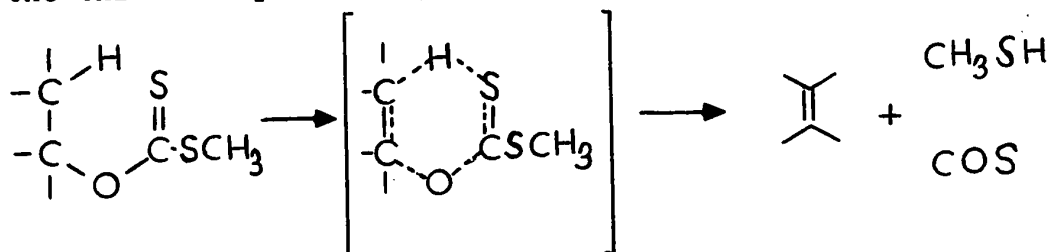

Fig. 2. Proposed Mechanism for the Pyrolysis of Xanthate Esters.

This mechanism is supported by the work of O'Connor and Nace<sup>3</sup> who observed that the decomposition of a series of S-alkyl cholesteryl xanthate followed first order kinetics. The cis nature of the elimination has been shown by the observation that cis-2-tert-butylcyclohexyl xanthate yielded exclusively 3-tert-butylcyclohexene on pyrolysis.<sup>4</sup> Cram<sup>5</sup> confirmed the stereochemistry by showing that the xanthate esters of threo- and erythro-3-phenyl-2-butanol decomposed stereospecifically with the formation of the corresponding cis- and trans-2-phenyl-2-butene, respectively as shown in Figure 3.

The involvement of thione sulphur in the transition state was supported by the kinetic isotope effects studies of Bourns and Bader<sup>6</sup>. The S<sup>34</sup> and C<sup>13</sup> isotope effects on the decomposition of S-methyl trans-2-methyl-1-indanyl xanthate indicated that

the thione sulphur atom was involved in the hydrogen abstraction step of the reaction.

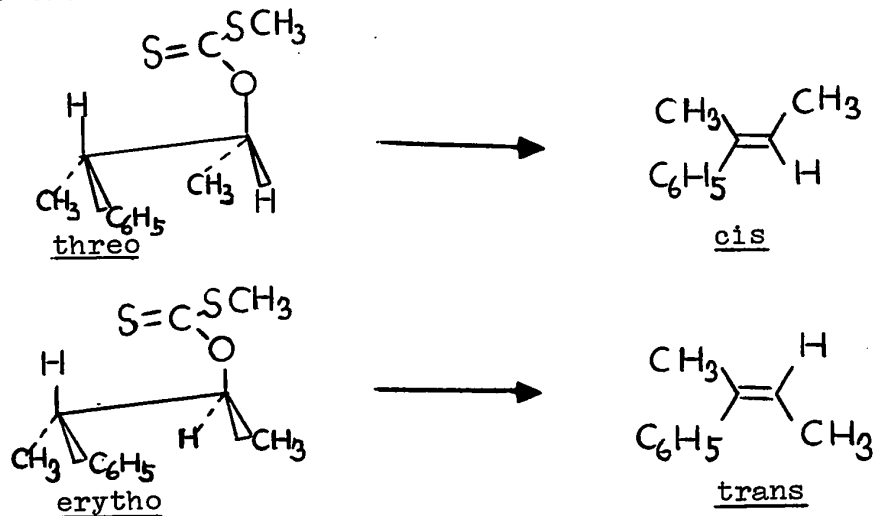

Fig. 3. Decomposition of S-Methyl Xanthate Esters of Threo- and Erythro-3-phenyl-2-butanol.

There are some conflicting results in literature concerning the cyclic mechanism in the pyrolysis of xanthate esters in general. Thus, McAlpine<sup>7</sup> observed that the S-isopropyl and S-p-nitrobenzyl menthyl xanthate esters pyrolysed more readily than the corresponding S-methyl compound. In 1956, a study of the decomposition of a series of S-alkyl cholesteryl xanthate esters was carried out by O'Connor and Nace.<sup>3</sup> They observed a decrease in the stability of the esters with an increase in the acidity of the leaving group. These authors reported a Hammett rho value of + 0.85 for the series. Although no reasons were offered for the observed differences in rates and the positive rho value, one might conclude that some electronic influences may be operative here and that the mechanism of decomposition shown in Figure 2 is affected to at least some degree by the nature of the substituents on the thiol-sulphur atom. Again, the

effect of the substituents on the alpha-carbon atom of the alcohol moiety on the stability of the xanthate esters has also been observed. Hence, Whitmore<sup>8</sup> reported that primary xanthates are much more stable to heat than are secondary and tertiary xanthates. Again, the decomposition of the xanthate ester of 2-octanol at reflux temperature yielded 60% of an olefinic mixture,<sup>9</sup> while the xanthate ester of trifluoromethyl-n-hexylcarbinol did not decompose under similar conditions (Fig. 4).<sup>10</sup>

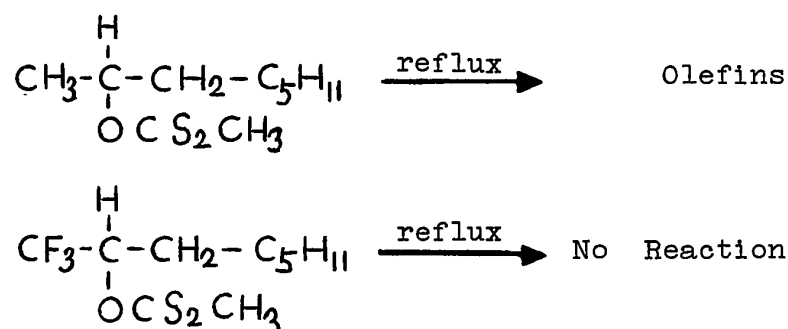
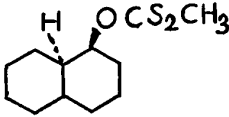

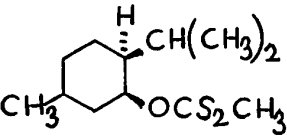
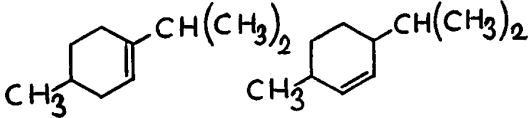
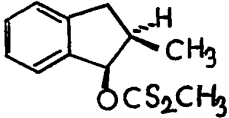
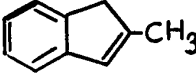
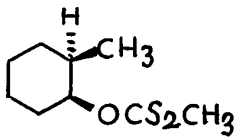

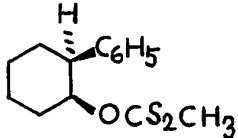
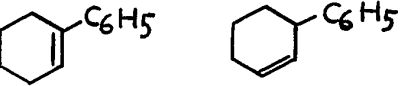

Fig. 4. Pyrolysis of the S-Methyl Xanthate Esters of 2-Octanol and Trifluoromethyl-n-hexylcarbinol.

Evidently, the electron withdrawing power of the alpha-trifluoromethyl substituent has a decided adverse electrical effect on the "ordering" of the cyclic transition state required for decomposition to olefin.

Other mechanisms have been proposed by some workers to explain the products obtained in some Chugaev reactions. Thus, an ionic mechanism was proposed to explain the trans-elimination products observed in the pyrolysis of some xanthate esters as shown in Table I which gives a list of trans-elimination products along with those derived from a predominant cis-elimination.

Table IPyrolysis of Xanthates Showing Both trans- and cis-Elimination Products.

<u>Xanthate</u>	<u>Olefin Distribution</u>	<u>Reference</u>
 <u>cis</u>	 20%                      80%	11
 <u>cis</u>	 20%                      80%	11
 <u>cis</u>	 20%	12 100°C - 30 min
 <u>cis</u>	 49%                      51%	13, 14
 <u>cis</u>	 0-7%                      93-100%	15 210-220 45 min

Recently, Djerassi and Briggs<sup>14</sup> studied the pyrolysis of the S-methyl xanthate ester of cis-2-methylcyclohexanol and its 2-d<sub>1</sub>-labeled analog. These authors found that there was a retention of deuterium label in 44% of the resultant 1-methyl-1-cyclohexene. This was explained by the formation of a carbonium ion intermediate as shown in Figure 5.

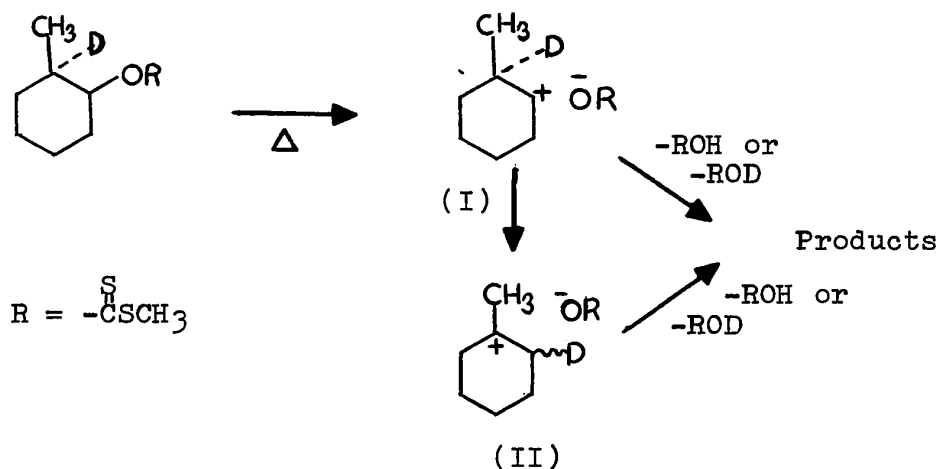

Fig. 5. A Proposed Carbonium Ion Intermediate in the Pyrolysis of the S-Methyl Xanthate Ester of Cis-2-methylcyclohexanol.

The species (I) may either lose a proton or deuterium directly or undergo a 1,2-deuteride shift to yield the more stable tertiary carbonium ion (II) which subsequently loses a proton or deuterium to yield the olefinic products.

A homolytic cleavage of the xanthate esters was proposed for the pyrolysis of S-p-bromophenacyl xanthates of some primary alcohols. Besides the expected Chugaev products, a substantial amount of alkyl bromides, starting alcohols, carbon disulphide and 4'-bromoacetophenone were found as shown in Figure 6.<sup>16</sup>

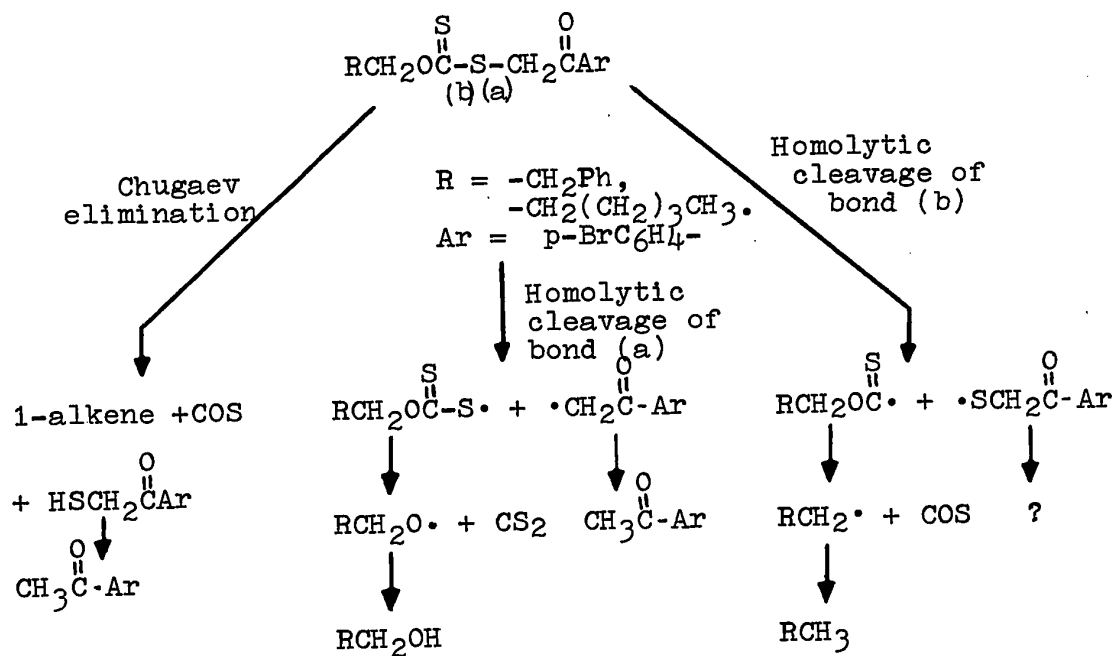

Fig. 6. A Proposed Homolytic Cleavage of the S-p-bromophenacyl Xanthate Esters of Some Primary Alcohols.

In 1958, Bordwell and Landis<sup>17</sup> reported a rather unique case of trans-elimination in a Chugaev reaction. These authors reported that cis-2-p-tolylsulphonylcyclohexyl xanthate (I) decomposed on heating to yield almost entirely 1-p-tolylsulphonylcyclohexene (II) as shown in Figure 7.

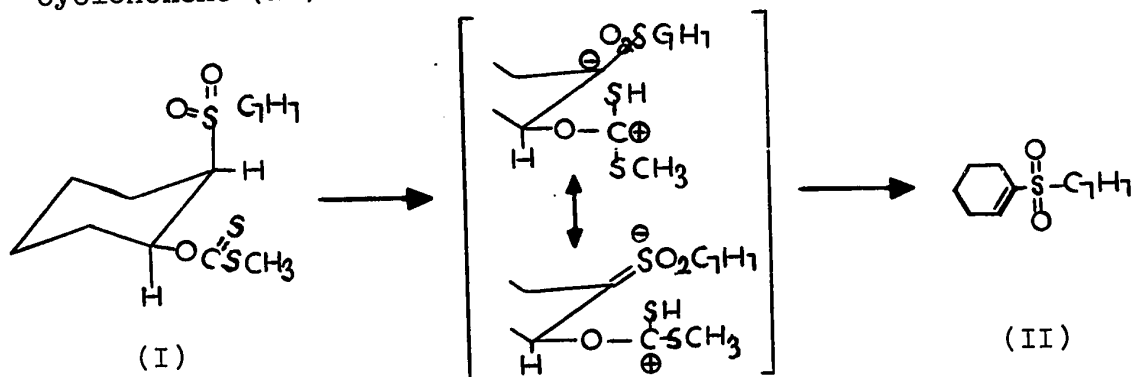

Fig. 7. Pyrolysis of S-Methyl Cis-2-p-tolylsulphonylcyclohexyl Xanthate.

The mechanism was interpreted as a trans-elimination which proceeded by a stepwise ionization of the beta-hydrogen atom, rendered more labile by the tosylate group on the same carbon atom. The effect of other labilizing groups on the beta-hydrogen atom has not been investigated.

Recently, some synthetic improvements of the Chugaev reaction were reported. Rutherford, Ottenbrite and Tang<sup>18</sup> found that pyrolysis of the potassium salt of several xanthate esters of tertiary alcohols proceeded smoothly to give higher olefin yields than the corresponding S-methyl xanthate esters. Moreover, the olefin distributions in most cases compared very favourably with those obtained from the pyrolysis of the corresponding S-methyl xanthate esters. However, when the potassium salt of the xanthate esters of primary and secondary alcohols were pyrolysed, only a very small amount of olefins were produced along with a large amount of the corresponding alcohols.<sup>19</sup>

Fackler<sup>20</sup> has shown that nickel (II) and other metal ions ( $\text{Sn}^{\text{IV}}$ ,  $\text{Cr}^{\text{III}}$ ) promote xanthate decomposition. The sensitivity of xanthate to the metal ion was seen from the fact that even aqueous solutions of potassium tert-butyl xanthate produced 10-15% yields of isobutene at room temperature when various metal halides were added. No olefins were found without added metal ion under the same conditions.

Burke, Bridgeford and Turbak<sup>21</sup> prepared S-alkyl xanthate esters with an unsaturated heteroatom one, two or three methylene groups removed from the thiol sulphur atom (Fig. 8). After refluxing in slightly acidic boiling water for various

periods of time, 40-60% olefinic yields could be obtained.

Lewis acids catalysts were found to enhance the olefinic yields.

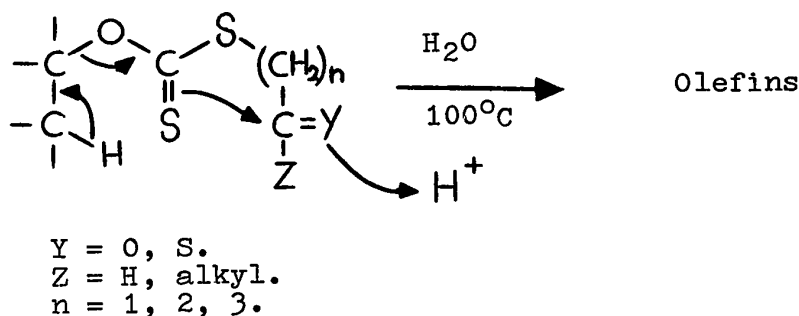

Fig. 8. BBT Procedure to Convert Xanthate to Olefins.

A rather interesting side reaction observed in the pyrolysis of some S-methyl xanthate esters involves the formation of dithiolcarbonates. For example, in the pyrolysis of the S-methyl xanthate ester of 1-cyclopropylethanol, Overberger<sup>22</sup> reported yields of 45% for the olefins and 53% for the dithiolcarbonates, of which the major component was identified as S-methyl 1-cyclopropylethyl dithiolcarbonate. A concerted four-membered cyclic transition state was suggested (Fig. 9).

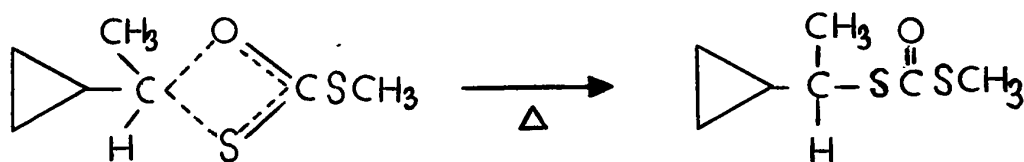

Fig. 9. A Cyclic Transition State Proposed for the Dithiolcarbonate Formation from Pyrolysis of S-Methyl 1-Cyclopropylethyl Xanthate.



Recently, this rearrangement reaction was studied by Taguchi and co-workers<sup>23, 24, 25</sup> who found that the pyrolysis of S-methyl trans-2-dimethylaminocyclohexyl xanthate gave only the corresponding dithiolcarbonate while the cis isomer underwent the expected elimination. Participation by the neighboring amino group was suggested in an ion-pair transition state (Fig. 10).

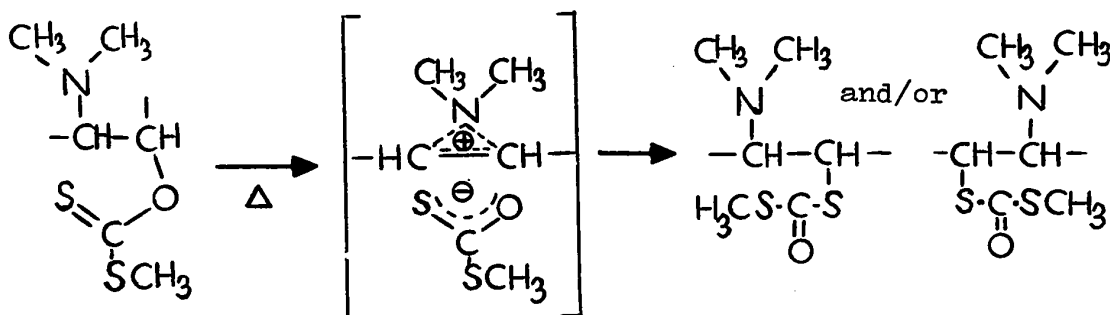

Fig. 10. A Proposed Ion-pair Transition State for the Dithiolcarbonate Formation from the Pyrolysis of S-Methyl Trans-2-dimethylaminocyclohexyl Xanthate.

In a study of the pyrolysis of some neopentyl xanthate esters, Laakso<sup>26</sup> reported no olefin formation whatsoever (Fig. 11).

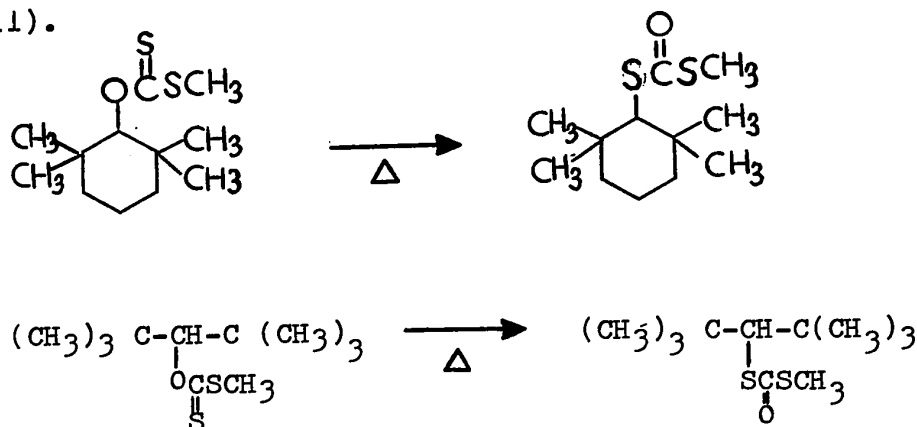

Fig. 11. Pyrolysis of Some Neopentyl Xanthate Esters.

The corresponding dithiolcarbonates were found in 70-80% yield. These results would appear to indicate that xanthate-dithiolcarbonate rearrangement is a true case of the classic cyclic S<sub>N</sub>i mechanism since one would surely expect in a neopentyl-type system at least some olefin formation derived from Wagner-Meerwein rearrangement<sup>27</sup> if an ion-pair intermediate existed. Therefore, a study was carried out to pyrolyse a series of neopentyl-type xanthates in order to investigate whether Laakso's results were a general phenomenon.

CHAPTER IIRESULTS AND DISCUSSIONSynthesis of Xanthates

A series of S-methyl xanthate ester of neopentyl-type alcohols were synthesized. All xanthates prepared shown in Table II were relatively stable. Thus these xanthates could be purified by distillation and/or crystallization. They were synthesized according to procedures developed in this laboratory<sup>18</sup> with the exception of the S-methyl p-bromoneophyl xanthate which was synthesized by the following route (Fig. 12).

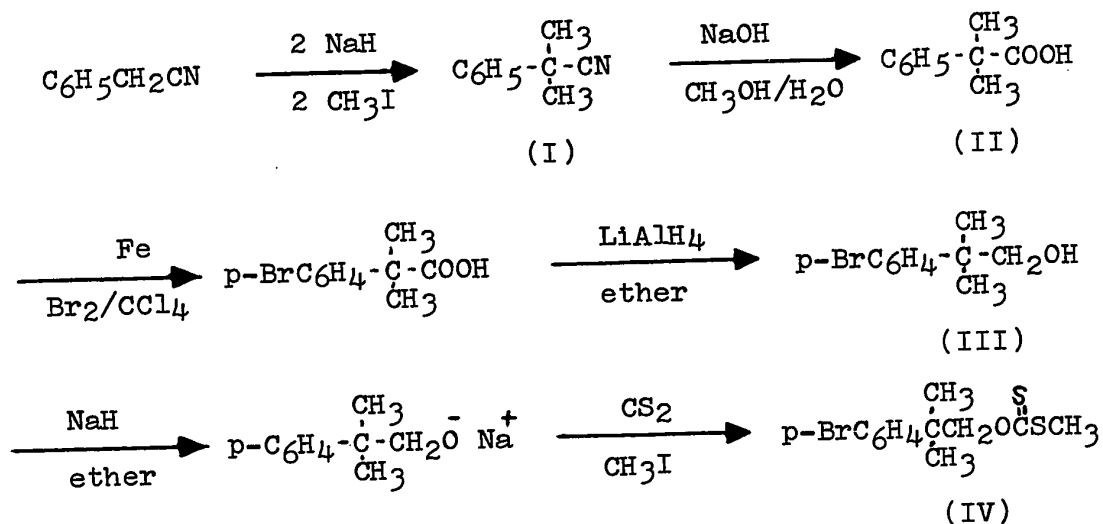

Fig. 12. Synthesis of S-Methyl p-Bromoneophyl Xanthate.

The neophyl nitrile (I) was synthesized according to the procedure of Hauser<sup>28</sup> in good yield. the nitrile was hydrolyzed successfully by the use of a modification of Heymingen's

procedure.<sup>29</sup> The acid (II) was brominated and reduced by the method of Winstein.<sup>30</sup> Treatment of the resultant alcohol (III) with potassium metal followed by reaction with carbon disulphide and methyl iodide gave a multicomponent mixture. However by using sodium hydride instead of potassium metal, a good yield of the xanthate (IV) was obtained (95%).

As shown in Table II boiling points and melting points of this series increase as the formula weight increases and as the number of beta-phenyl substituted group increases. It is interesting to note that neopentyl xanthate did not decompose even at reflux temperature for twenty-four hours. Again while an electron withdrawing group at the para-position of the beta-phenyl group raises the decomposition temperature, an electron donating group reduces it. The increase substitution of beta-phenyl group also reduces the decomposition temperature of a given ester.

It was then decided to study the pyrolytic products in detail because the decomposition of these xanthates suggested that a Wagner-Meerwein rearrangement may be occurring. The pyrolytic temperature was chosen to be 250°C because it represented an intermediate decomposition temperature for this series.

Table IIXanthate Derivative

<u>Xanthate</u>	<u>mp °C</u>	<u>bp °C</u>	<u>Decomposition Temperature °C</u>
$(\text{CH}_3)_3\text{CCH}_2\text{OX}$		217 (760mm)	*
$p\text{-BrC}_6\text{H}_4(\text{CH}_3)_2\text{CCH}_2\text{OX}$		135 (0.1mm)	300
$\text{C}_6\text{H}_5(\text{CH}_3)_2\text{CCH}_2\text{OX}$		105 (0.2mm)	280
$p\text{-CH}_3\text{C}_6\text{H}_4(\text{CH}_3)_2\text{CCH}_2\text{OX}$		122 (0.3mm)	270
$(\text{C}_6\text{H}_5)_2(\text{CH}_3)\text{CCH}_2\text{OX}$	52-53		245
$(\text{C}_6\text{H}_5)_3\text{CCH}_2\text{OX}$	97-98		210

\* no decomposition at boiling temperature.

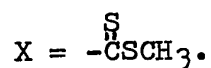

### Product Studies

Weighed amounts of xanthate were heated at 250°C for thirty minutes and/or several hours when required. Olefins were separated by gas liquid chromatography and were indentified by standard procedures. The relative amounts of each olefin were determined by the use of gas liquid chromatography and nuclear magnetic resonance spectroscopy. The residues were analyzed by similar routes. A summary of product distributions is shown in Table III.

As can be seen from Table III no olefin was observed after heating S-methyl neopentyl xanthate at 250°C for forty hours. A 42% yield of the S-methyl neopentyl dithiolcarbonate was found to be the only reaction product.

On the other hand, S-methyl 2,2,2-triphenylethyl xanthate gave 100% phenylstilbene and no dithiolcarbonate was observed after heating for thirty minutes. Attempts to observe any dithiolcarbonate formation during the pyrolysis were unsuccessful at 160°C and 200°C for various periods of time.

Pyrolysis of the S-methyl xanthate ester of 2,2-diphenylpropanol at 250°C for thirty minutes yielded 88% of an olefinic mixture, 8% of unreacted starting xanthate and a small amount of residual products ( 4%). Although the material was not isolated in a pure state, the infrared spectrum showed the characteristic bands of dithiolcarbonate.

In the olefinic portion only phenyl migration was observed to the complete exclusion of methyl migration. The olefin distribution was determined both by gas liquid chroma-

Table III

Pyrolysis of Neopentyl-type Xanthate at 250°C.

Xanthate	Time (hour)	Product Distribution %					Unknown	
		Unreacted Xanthate	Dithiol-carbonate	Olefin Yield	Olefin Distribution			
$(\text{CH}_3)_3\text{CCH}_2\text{OX}$	0.5	99	1	0			1	
	20.0	64	35	0			1	
	40.0	57	42	0				
$\text{C}_6\text{H}_5(\text{CH}_3)_2\text{CCH}_2\text{OX}$	0.5	75	8	17	$\begin{array}{c} 11.5 \\ \text{H} \quad \text{CH}_3 \\ \diagdown \quad / \\ \text{C} \\ / \quad \diagdown \\ \text{H} \quad \text{CH}_2\text{C}_6\text{H}_5 \end{array}$	$\begin{array}{c} 5.5 \\ \text{CH}_3 \quad \text{C}_6\text{H}_5 \\ \diagdown \quad / \\ \text{C} \\ / \quad \diagdown \\ \text{CH}_3 \quad \text{H} \end{array}$		
	2.0	32	22	45	30	15		
$\text{CH}_3(\text{C}_6\text{H}_5)_2\text{CCH}_2\text{OX}$	0.5	8		88	$\begin{array}{c} 43 \\ \text{H} \quad \text{C}_6\text{H}_5 \\ \diagdown \quad / \\ \text{C} \\ / \quad \diagdown \\ \text{H} \quad \text{CH}_2\text{C}_6\text{H}_5 \end{array}$	$\begin{array}{c} 35 \\ \text{CH}_3 \quad \text{C}_6\text{H}_5 \\ \diagdown \quad / \\ \text{C} \\ / \quad \diagdown \\ \text{C}_6\text{H}_5 \end{array}$	$\begin{array}{c} 10 \\ \text{C}_6\text{H}_5 \quad \text{H} \\ \diagdown \quad / \\ \text{C} \\ / \quad \diagdown \\ \text{CH}_3 \quad \text{C}_6\text{H}_5 \end{array}$	4
	0.5	0	0	100	$\begin{array}{c} \text{C}_6\text{H}_5 \quad \text{H} \\ \diagdown \quad / \\ \text{C} \\ / \quad \diagdown \\ \text{C}_6\text{H}_5 \end{array}$			

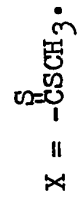

tography and nuclear magnetic resonance spectroscopy and contained 49% 1-benzylstyrene, 35% methyl-cis-stilbene and 12% methyl-trans-stilbene. An isomerization study of the olefins revealed that both the trans- and cis-stilbene were stable under the same pyrolytic conditions. However, a transformation of 48% of 1-benzylstyrene to the methyl-trans-stilbene was found. Therefore, the 10% methyl-trans-stilbene observed on the pyrolysis of the xanthate ester may have been derived from 1-benzylstyrene.

The pyrolysis of S-methyl neophyl xanthate gave both olefins and dithiolcarbonate at 250°C. The dithiolcarbonate was identified as S-methyl neophyl dithiolcarbonate by the following route (Fig. 13).

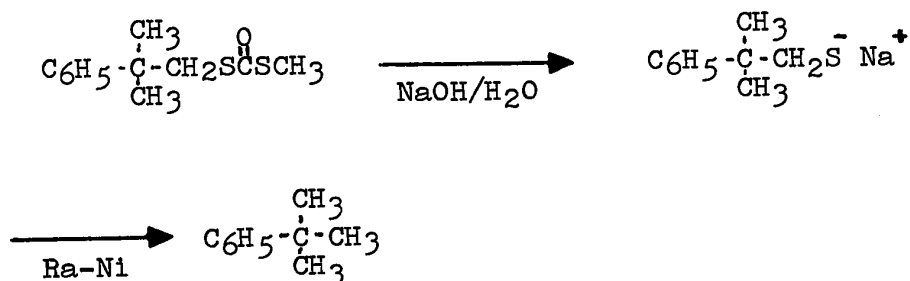

Fig. 13. Identification of the S-Methyl Neophyl Dithiolcarbonate.

Base hydrolysis followed by reduction with Raney Nickel gave only tert-butylbenzene. No rearranged dithiolcarbonate was observed. The olefinic portion was found to consist only of 2,2-dimethylstyrene and 2-benzylpropene. Here again only products derived from phenyl migration were obtained. The



unconjugated-to-conjugated olefin ratio was found to be 2 : 1. An isomerization study of both olefins showed that no transformation of the unconjugated to the conjugated isomer occur under the pyrolytic conditions.

The pyrolysis of S-methyl p-bromoneophyl xanthate gave both olefins and dithiolcarbonate. However, p-methylneophyl xanthate gave less than 4% of the dithiolcarbonate after heating for thirty minutes (70% of the completed reaction). The olefin distributions were not studied in detail for both compounds.

To summarize the results of Table III the following salient points should be noted :

(1) Neopentyl xanthate undergoes only rearrangement to the dithiolcarbonate. No evidence of methyl group participation was observed.

(2) Increasing beta-phenyl substitution leads to increasing amounts of olefin formation. The olefinic products are derived only from phenyl migration. No xanthate-dithiolcarbonate rearrangement was observed at all in the decomposition of the triphenyl-substituted xanthate ester and only a small amount (<4%) was observed in the diphenyl-substituted system.

(3) There is a predominance of Hofmann-type olefins.

(4) No skeletal rearranged dithiolcarbonate was observed.

These observations prompted a further study into the course and nature of the pyrolysis of the xanthates under investigation.

There are three probable ways to account for the products:

(a) Two competing processes to afford both olefin (s) and dithiolcarbonate;

(b) a consecutive process and

(c) a competing-consecutive process (Fig. 14).

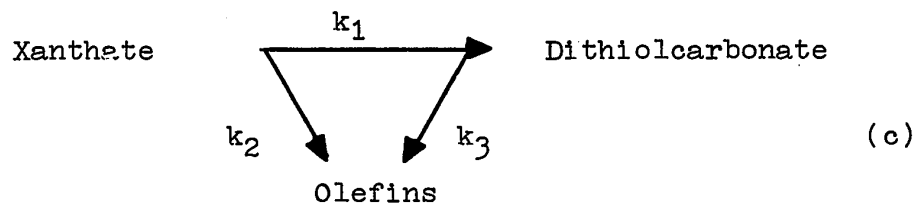
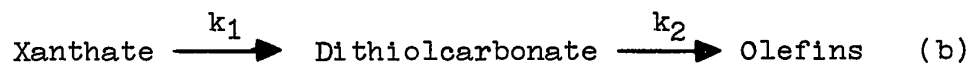
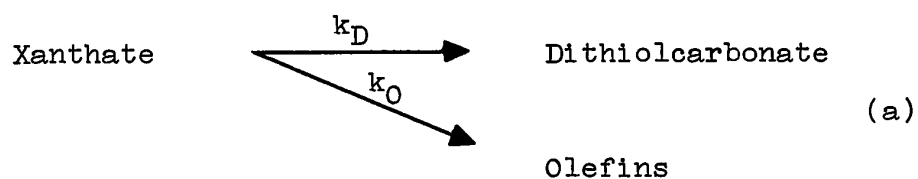

Fig. 14. The Probable Courses of Reaction for the Pyrolysis of Neopentyl-type Xanthates.

A kinetic study of the pyrolysis of these xanthates was undertaken in the hope that the results would help to differentiate between the above processes.

Kinetic Studies

Attempts to follow the decomposition of xanthate by gas liquid chromatography were unsuccessful partly because some of the xanthate esters decomposed in the injection port and partly because some of the reaction products had a prohibitively long retention time.

A convenient method was developed which involved following the reaction with nuclear magnetic resonance spectroscopy using methyl benzoate as an internal standard. The thiolmethyl group of both xanthates and dithiolcarbonates and the methyl group of the methyl benzoate were chosen for integration. The relative amounts of the xanthates left were determined in the following manner:

$$\frac{[X]}{[S]} = \left( \frac{Ax}{As} \right)_t \quad (1)$$

$[X]$  = concentration of xanthate at time  $t$ ,

$[S]$  = concentration of the internal standard,

$Ax$  = area of the thiolmethyl group of the xanthate,

$As$  = area of the internal standard.

$$\frac{[X_0]}{[S]} = \left( \frac{Ax}{As} \right)_0 \quad (2)$$

$[X_0]$  = concentration of xanthate at time zero.

Dividing (2) by (1),

$$\frac{[X_0]}{[X]} = \left( \frac{Ax}{As} \right)_0 \bigg/ \left( \frac{Ax}{As} \right)_t \quad (3)$$

Small samples of the xanthates were placed in loosely corked test tubes or sealed test tubes (under a nitrogen atmosphere) and were suspended in a constant temperature silicone oil bath. At set intervals, samples were quenched in ice and analyzed by nuclear magnetic resonance spectroscopy. The temperature of the oil bath was maintained at 250°C for the decompositions of all the xanthates except S-methyl 2,2,2-triphenylethyl xanthate. This latter compound (Table II) decomposed at an inconveniently fast rate at 250°C and as a result the rate constant at this temperature was estimated by extrapolation of the Arrhenius equation graphically solved with decomposition rate data between 174° - 220°C.

The rate constants of the disappearance of the xanthates ( $k_t$ ) were determined from the first order rate equation. A plot of  $\log\left(\frac{[X_o]}{[X]}\right)$  vs time as shown in Figures 15, 16, 17 and 18 showed first order kinetics for these neopentyl-type xanthates. Figure 15 also showed a first order plot of the formation of S-methyl neopentyl dithiolcarbonate. Figure 19 shows a linear relationship between  $\log k_t$  of S-methyl 2,2,2-triphenylethyl xanthate and the reciprocal absolute temperatures with the Arrhenius constants  $A = (15 \pm 2) \times 10^{13} \text{ sec}^{-1}$  and  $E = (39 \pm 4) \text{ Kcal / mole}$ . The  $k_t$  at 250°C was then calculated by extrapolation and found to be  $(9.2 \pm 0.7) \times 10^3 \text{ sec}^{-1}$ . The rate constants of the pyrolysis of these xanthates are shown in Table IV.

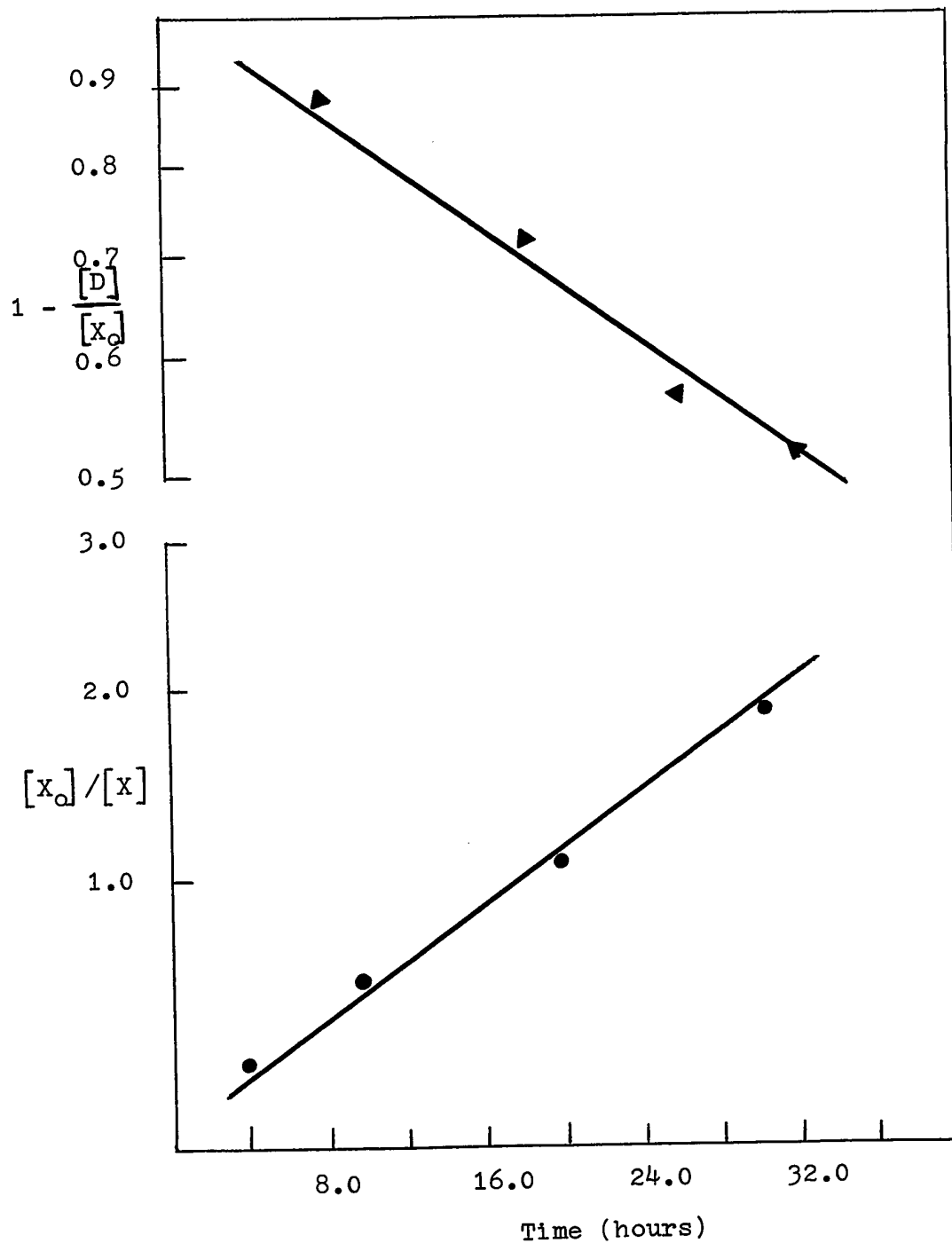

Fig. 15. The First Order Kinetic Plots of the Disappearance of S-Methyl Neopentyl Xanthate [X] and the formation of Neopentyl Dithiolcarbonate [D] at 250°C on a Semi-logarithmic Paper.

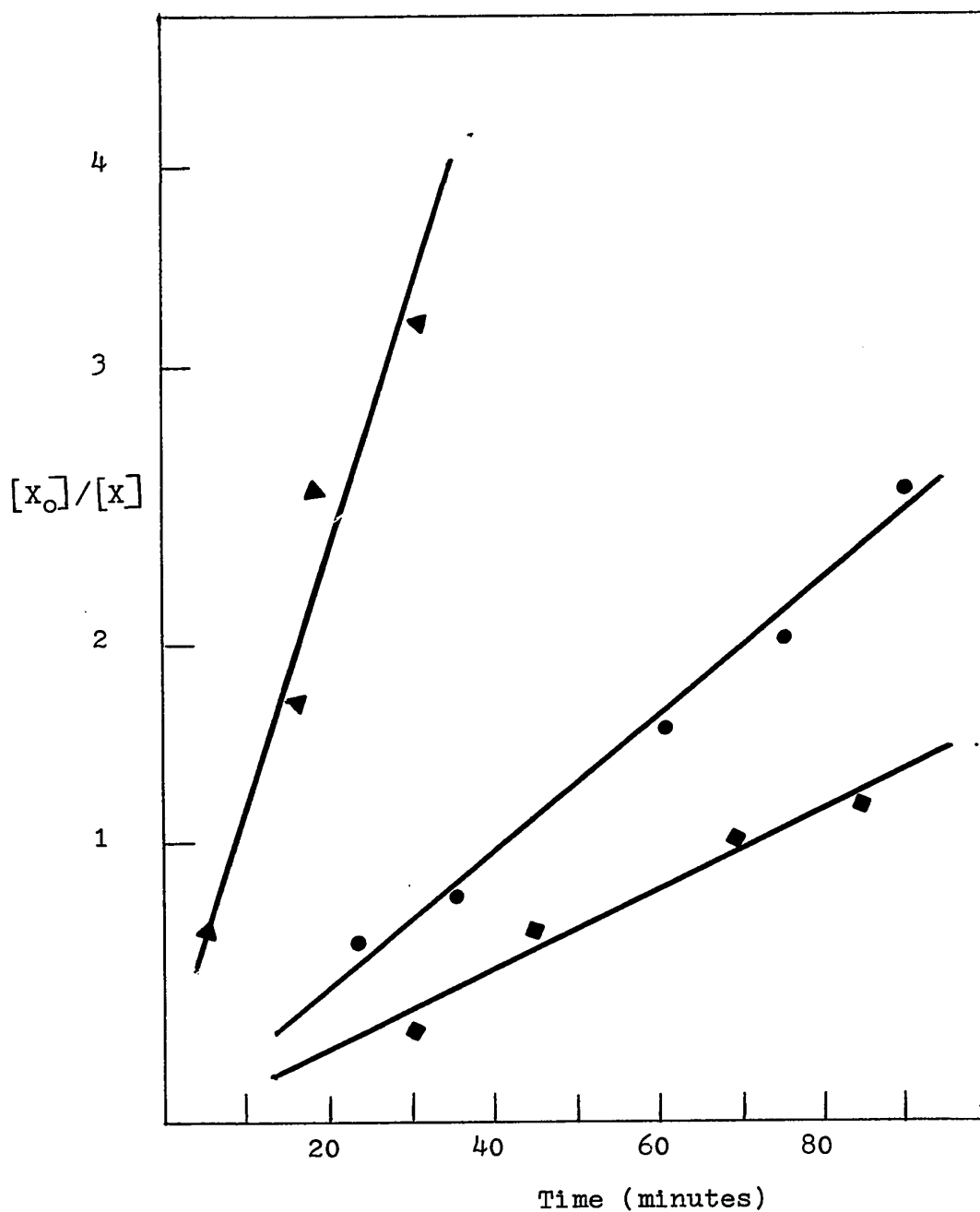

Fig. 16. The First Order Kinetic Plots of the Disappearance of S-Methyl p-Bromoneophyl (◆), Neophyl (●) and p-Methylneophyl (▶) Xanthates at 250°C on a Semi-logarithmic Paper.

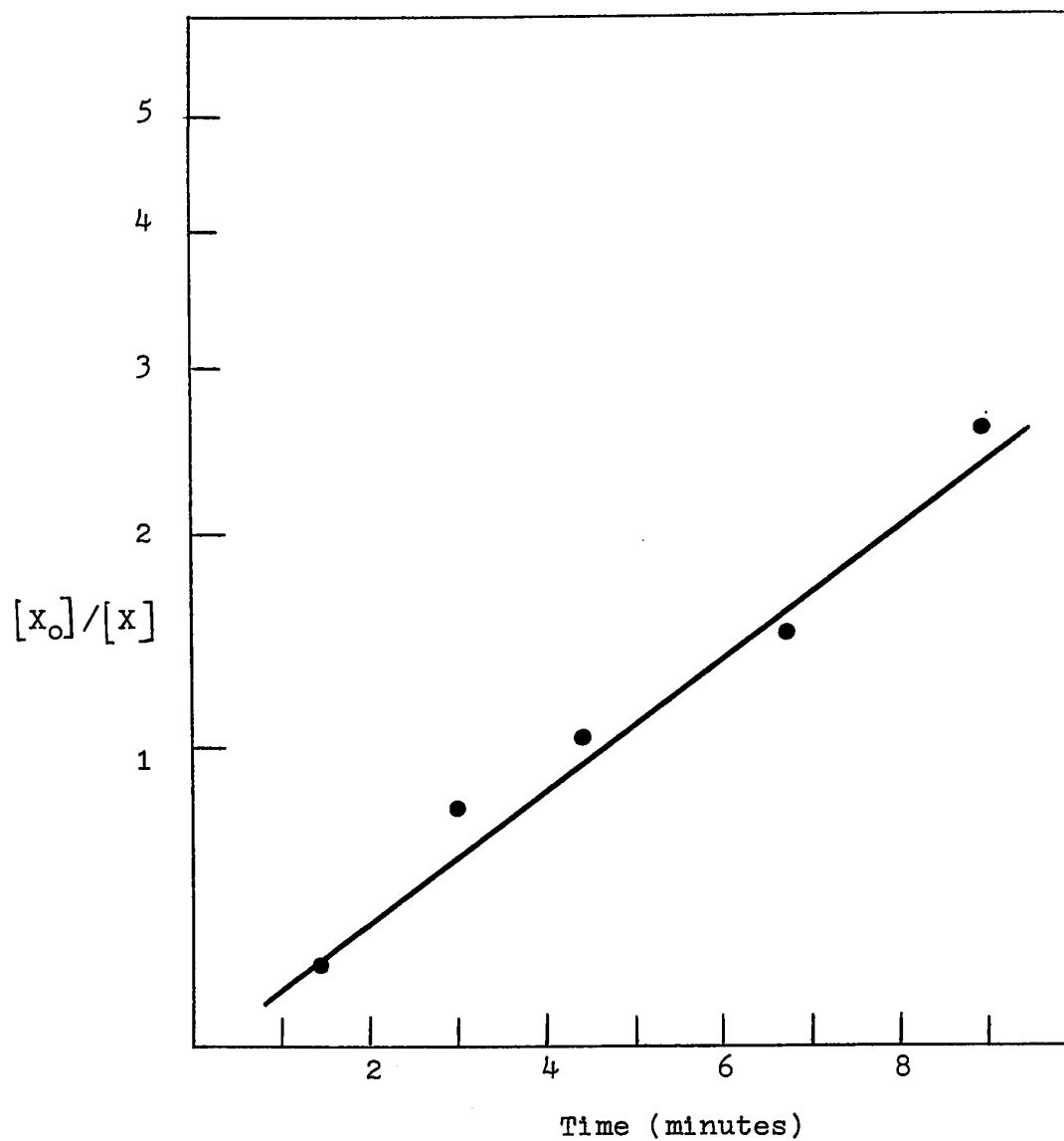

Fig. 17. The First Order Kinetic Plots of the Disappearance of S-Methyl 2,2-Diphenylpropyl Xanthate at 250°C on a Semi-logarithmic Paper.

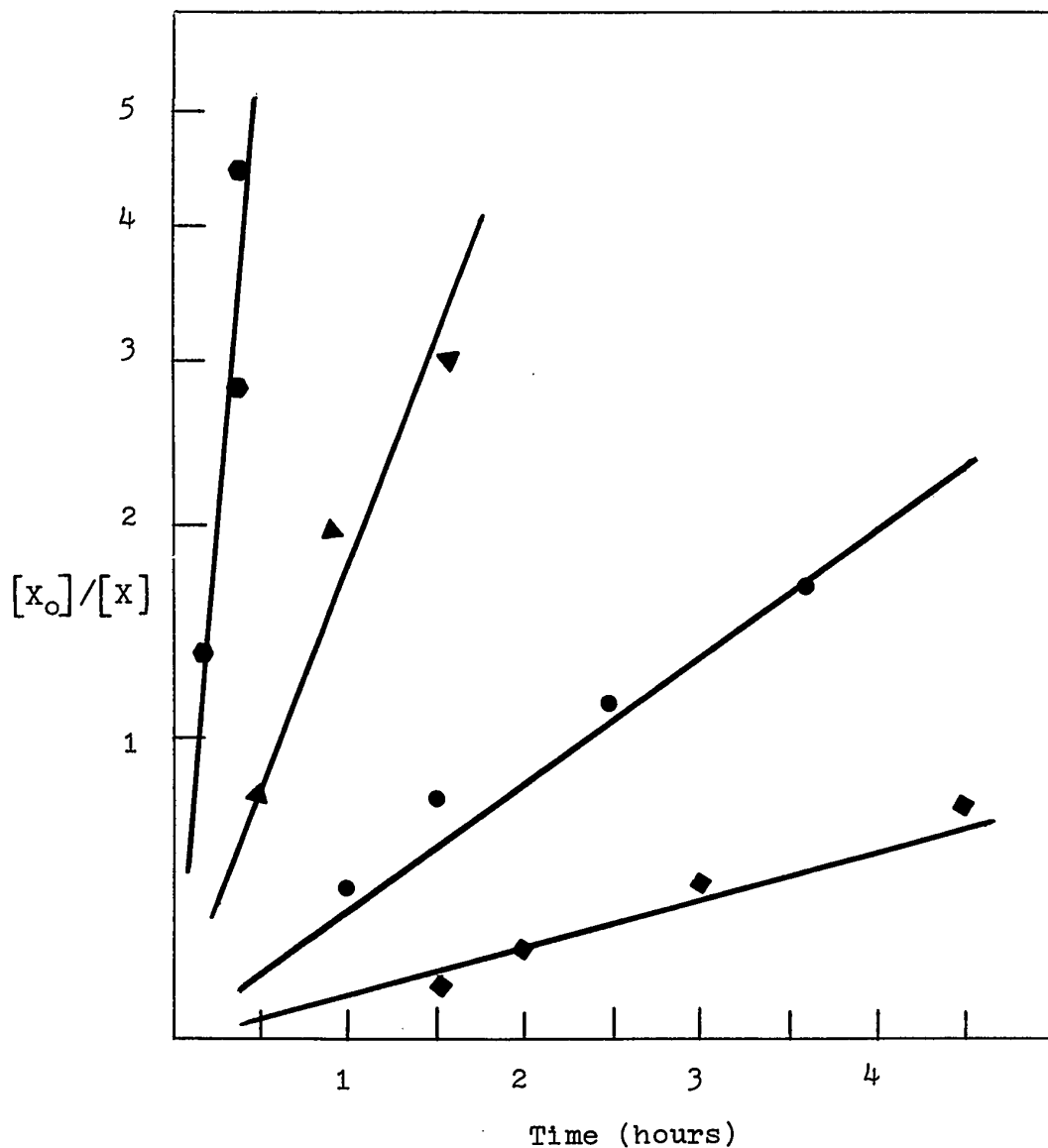

Fig. 18. The First Order Kinetic Plots of the Disappearance of S-Methyl 2,2,2-Triphenylethyl Xanthates at Four Different Temperatures on a Semi-logarithmic Paper: (◆) 174°C; (●) 185°C; (▶) 200°C; (●) 220°C.



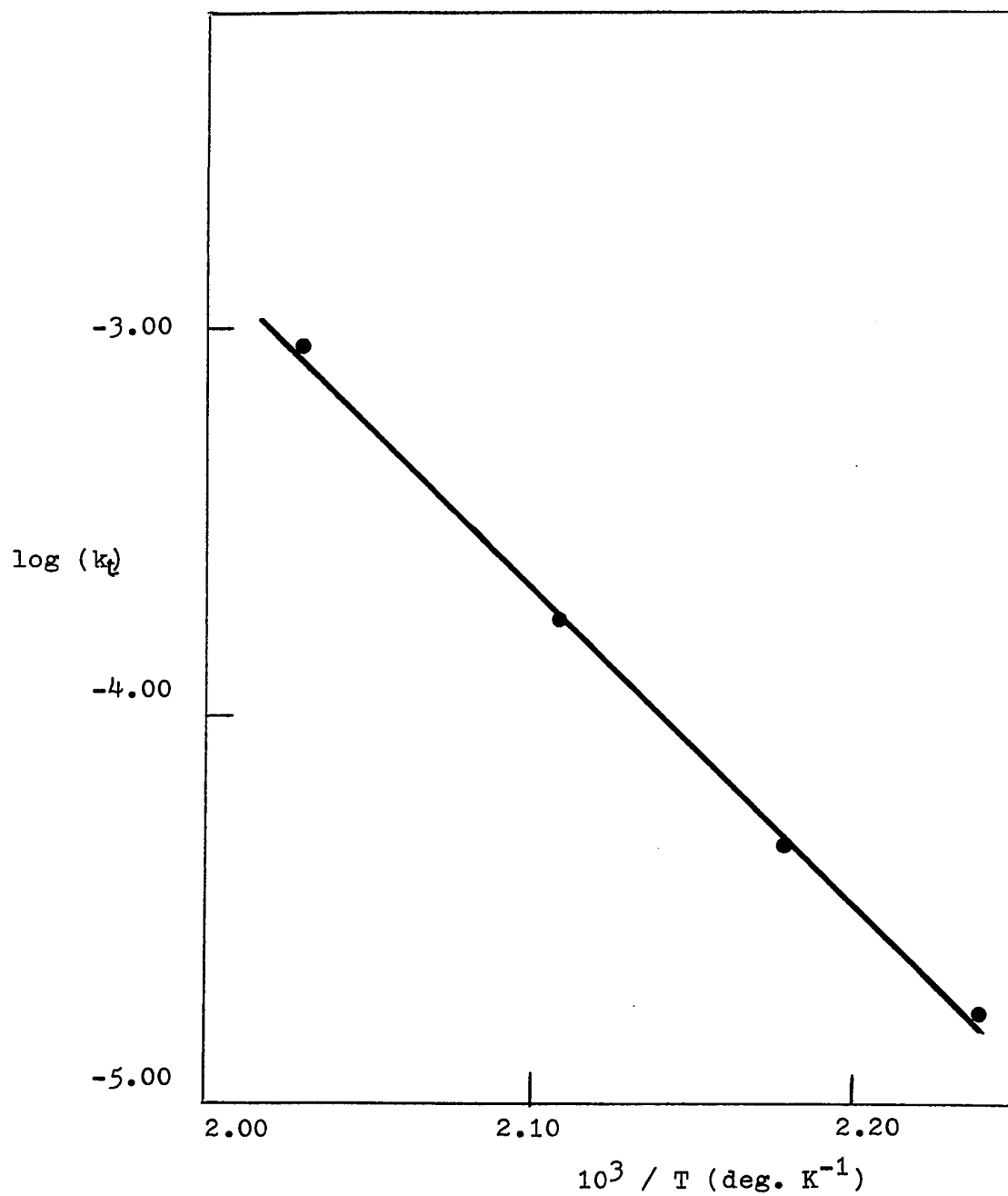

Fig. 19. The Logarithm of Rate Constants Obtained from the Pyrolysis of S-Methyl 2,2,2-Triphenylethyl Xanthate was plotted Against the Reciprocal of the Absolute Temperature.

Table IV

Pyrolysis of Neopentyl-type Xanthate at 250°C

Xanthate	$k_t \text{ sec}^{-1}$	$k_D \text{ sec}^{-1}$
$(\text{CH}_3)_3\text{CCH}_2\text{OX}$	$(6.2 \pm 0.7) \times 10^{-6}$	$(5.9 \pm 0.7) \times 10^{-6}$
$p\text{-BrC}_6\text{H}_4(\text{CH}_3)_2\text{CCH}_2\text{OX}$	$(9.1 \pm 0.7) \times 10^{-5}$	$(3.4 \pm 0.7) \times 10^{-5}$
$\text{C}_6\text{H}_5(\text{CH}_3)_2\text{CCH}_2\text{OX}$	$(16 \pm 0.7) \times 10^{-5}$	$(5.0 \pm 0.7) \times 10^{-5}$
$p\text{-CH}_3\text{C}_6\text{H}_4(\text{CH}_3)_2\text{CCH}_2\text{OX}$	$(7.0 \pm 0.7) \times 10^{-4}$	*
$\text{CH}_3(\text{C}_6\text{H}_5)_2\text{CCH}_2\text{OX}$	$(15 \pm 0.7) \times 10^{-4}$	*
$(\text{C}_6\text{H}_5)_3\text{CCH}_2\text{OX}$	** $(9.2 \pm 0.7) \times 10^{-3}$	0

$k_t$  = rate constant of disappearance of xanthate.

$k_D$  = rate constant of formation of dithiolcarbonate.

\* not available.

\*\* calculated from Figure 19.

If a given reaction occurs by two first order competing processes as shown in (a) of Figure 14, then

$$\frac{d[X]}{d t} = -k_t [X] \quad (4)$$

$$\frac{d[D]}{d t} = k_D [X] \quad (5)$$

$$\frac{d[O]}{d t} = k_O [X] \quad (6)$$

$k_t$  = rate constant of disappearance of xanthate,  
 $k_D$  = rate constant of dithiolcarbonate formation,  
 $k_O$  = rate constant of olefin formation,  
 $[X]$  = concentration of xanthate at time  $t$ ,  
 $[X_0]$  = concentration of xanthate at time zero,  
 $[D]$  = concentration of dithiolcarbonate,  
 $[O]$  = concentration of olefin (s).

Integrating (4)  $[X] = [X_0] e^{-k_t(t)} \quad (7)$

Integrating (5)  $[D] = \frac{-k_D}{k_t} [X - X_0] \quad (8)$

Integrating (6)  $[O] = \frac{-k_O}{k_t} [X - X_0] \quad (9)$

Dividing (8) by (9)  $\frac{[D]}{[O]} = \frac{k_D}{k_O}$  or  $k_O = k_D \frac{[O]}{[D]} \quad (10)$

Material balance, gave

$$[X_0 - X] = [D] + [O] \quad (11)$$

Substitute (8) and (9) into (11)

$$k_t = k_D + k_o \quad (12)$$

Substitute (10) into (12)

$$k_t = k_D \left( 1 + \frac{[O]}{[D]} \right) \quad (13)$$

Thus for two competing processes the plot of  $[D]$  vs  $[X - X_o]$  should be a straight line as predicted by equation (8). If so, equations (12) and (13) are also satisfied.

Figure 20 confirms the linear relationship between  $[D]$  and  $[X_o - X]$  for both S-methyl neophyl and S-methyl p-bromoneophyl xanthates. The rates of dithiolcarbonate formation ( $k_D$ ) were calculated from the slopes of these lines and are shown in Table IV. Thus the production of olefin and dithiolcarbonate are two competitive processes in the pyrolysis of these two compounds, and because of this, equations (12) and (13) are true.

Further studies showed that there was no olefin formation from the pyrolysis of S-methyl neopentyl and neophyl dithiolcarbonates under similar experimental conditions. On this basis, the consecutive process and the competing-consecutive process can be eliminated from further consideration. Therefore the Wagner-Meerwein rearrangement and the dithiolcarbonate formation appeared to be two competing processes, and subsequently they are discussed separately below.

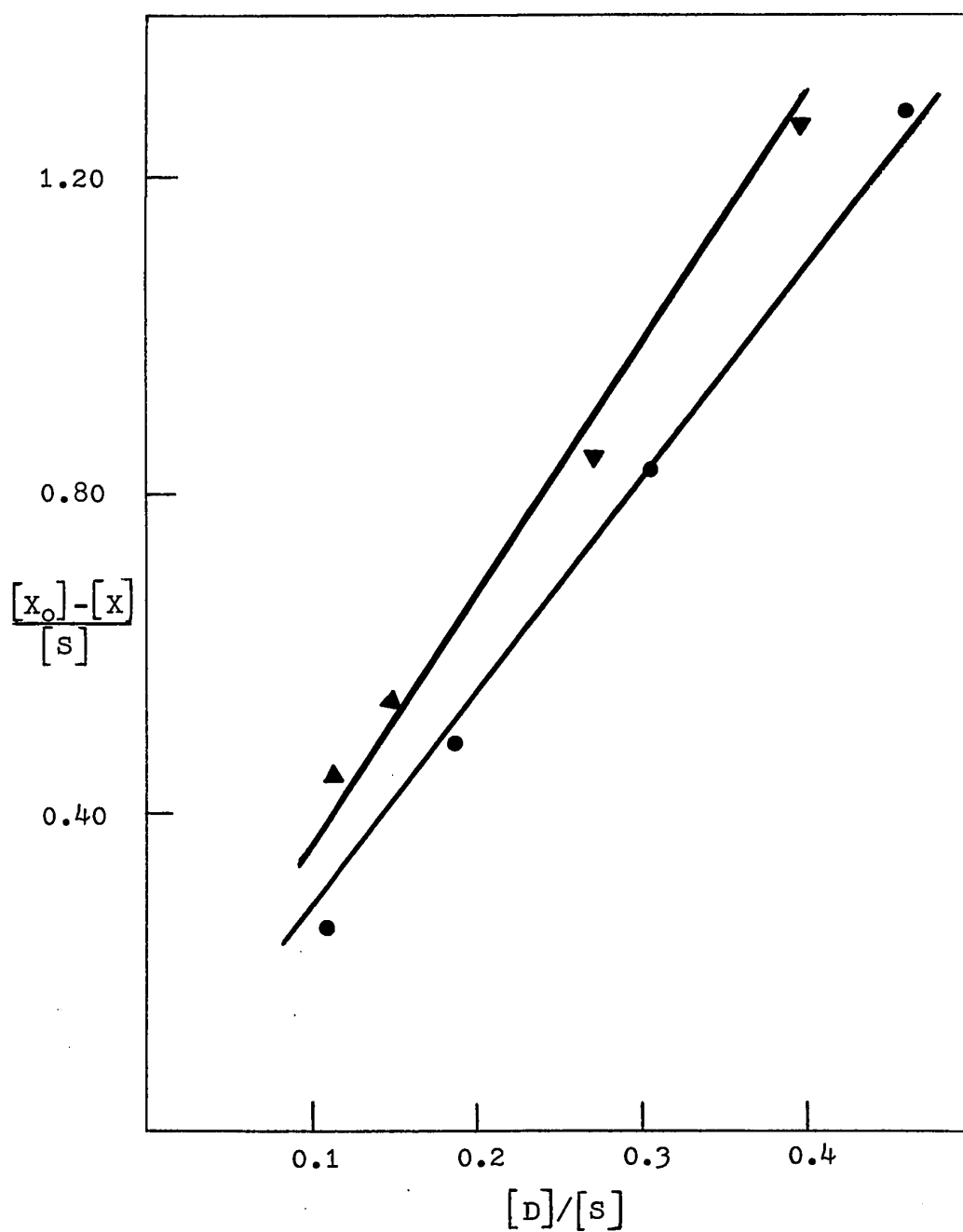

Fig. 20. The Rate of Disappearance of S-Methyl p-Bromoneophyl (●) and Neophyl (▶) Xanthates Against the Rate of Formation of the Corresponding Dithiolcarbonates.

### Wagner-Meerwein Rearrangement Leading to Olefin Formation

The rate constants of olefin formation ( $k_0$ ) were calculated according to equation (12). For S-methyl 2,2-diphenylpropyl, p-methylneophyl and 2,2,2-triphenylethyl xanthates, it was assumed that  $k_0 = k_t$  because less than 5% of dithiolcarbonate was observed after 70% completion of the pyrolysis.

Table V suggests that the rate of olefin formation increases with the degree of substitution of beta-phenyl groups particularly when the phenyl groups are para-substituted with an electron donating group. These observations parallel those in the acetolysis of neopentyl-type brosylates.<sup>30</sup> Figure 21 shows a linear free energy relationship between the data of the two systems<sup>31</sup> and indicates that there is a reasonably good correlation. It had been demonstrated that the acetolysis rates of neophyl brosylates were moderately sensitive to substitution effects and a Hammett plot of  $\sigma^+$  values indicated a rho value of -2.96 for this reaction. These authors concluded that ionization with phenyl participation was the rate determining step.

In the xanthate system, the decomposition rates of the substituted neophyl xanthates were moderately sensitive to the nature of substituents. This observation coupled with the apparent similarity with the neophyl brosylate system suggests a phenonium ion transition state for the olefin forming process as shown in Figure 22.

Table V

Rates of Acetolysis of Neopentyl-type Brosylates ( $k_s$ ) at 75°C and Calculated Rates of Olefin Formation in the Pyrolysis of Neopentyl-type Xanthates ( $k_0$ ) at 250°C.

	<u>Pyrolysis of Xanthates</u>		<u>Acetolysis of Brosylates</u>	
	$k_0 \text{ sec}^{-1}$	$-\log k_0$	$k_s \text{ sec}^{-1}$	$-\log k_s$
$p\text{-BrC}_6\text{H}_4(\text{CH}_3)_2\text{CCH}_2\text{OH}$	$(5.7 \pm 0.7) \times 10^{-5}$	4.2-4.3	$1.09 \times 10^{-5}$	4.96
$\text{C}_6\text{H}_5(\text{CH}_3)_2\text{CCH}_2\text{OH}$	$(11 \pm 0.7) \times 10^{-5}$	3.9-4.0	$6.84 \times 10^{-5}$	4.12
$p\text{-CH}_3\text{C}_6\text{H}_4(\text{CH}_3)_2\text{CCH}_2\text{OH}$	$(7.0 \pm 0.7) \times 10^{-4}$	3.1-3.2	$5.00 \times 10^{-4}$	3.30
$\text{CH}_3(\text{C}_6\text{H}_5)_2\text{CCH}_2\text{OH}$	$(15 \pm 0.7) \times 10^{-4}$	2.8-2.9		
$(\text{C}_6\text{H}_5)_3\text{CCH}_2\text{OH}$	$(9.2 \pm 0.7) \times 10^{-3}$	2.0-2.1	$1.06 \times 10^{-3}$	2.98

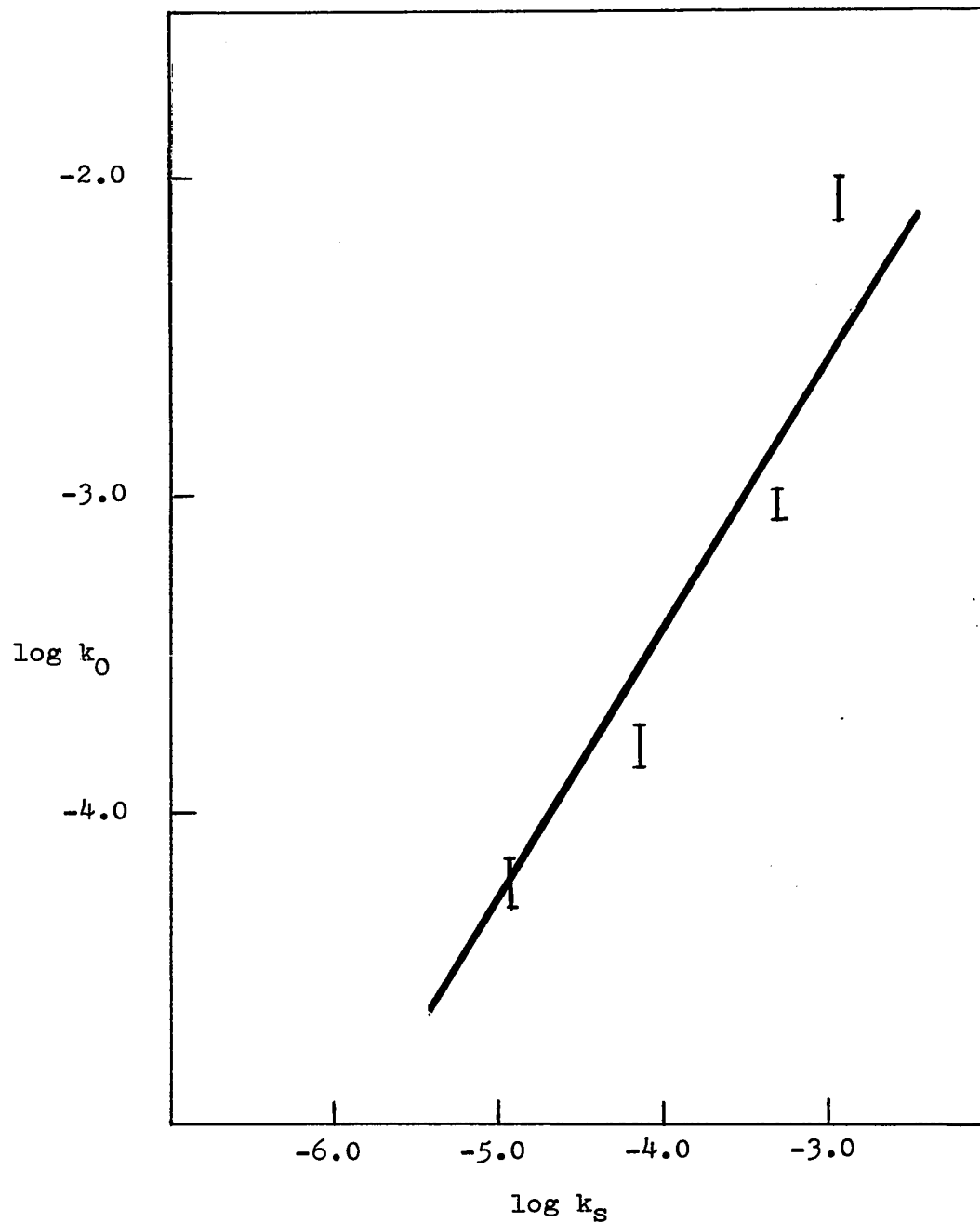

Fig. 21. The Linear Free Energy Plot of the Rates of Pyrolysis of Neopentyl-type Xanthates ( $k_0$ ) and the Rates of Acetolysis of Neopentyl-type Brosylates ( $k_s$ ).



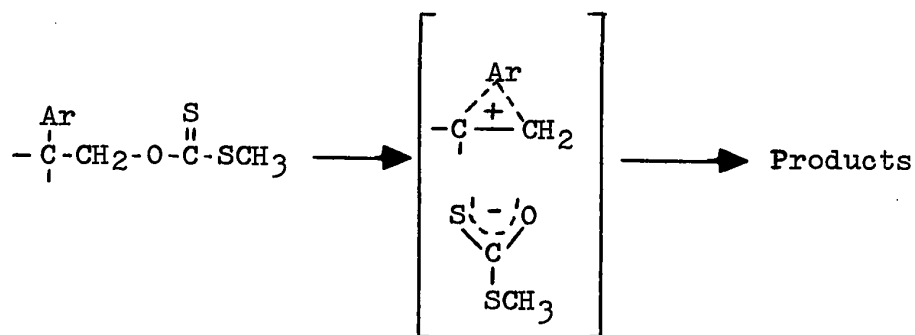

Fig. 22. Proposed Transition State for the Olefin (s) Formation Process.

Figure 23 is a Hammett-Taft plot that shows a fair correlation between the  $\sigma^+$  values of the neophyl substituents and the apparent rate of olefin formation of these xanthates. This further supports the proposed involvement of the phenonium ion transition state.

It is interesting to note that there is a predominance of the Hofmann-type olefins in the product. In the acetolysis of neophyl brosylate, the 2-benzylpropene to the 2,2-dimethylstyrene ratio was 1 : 1.<sup>30</sup> Kwart<sup>32, 33</sup> reported a ratio of 2.2 : 1 in the pyrolysis of neophyl acetate in gas phase at 575°C. Statistically speaking, the 1-ene to 2-ene ratio should be 3 : 1. Since in the pyrolysis of neophyl xanthate the observed ratio is 2 : 1, the larger than statistically predicted amount of conjugated olefin formed in the reaction suggests that both statistical and thermodynamic effects are important.

The 1-ene to 2-ene ratio should be 3 : 2 in the pyrolysis

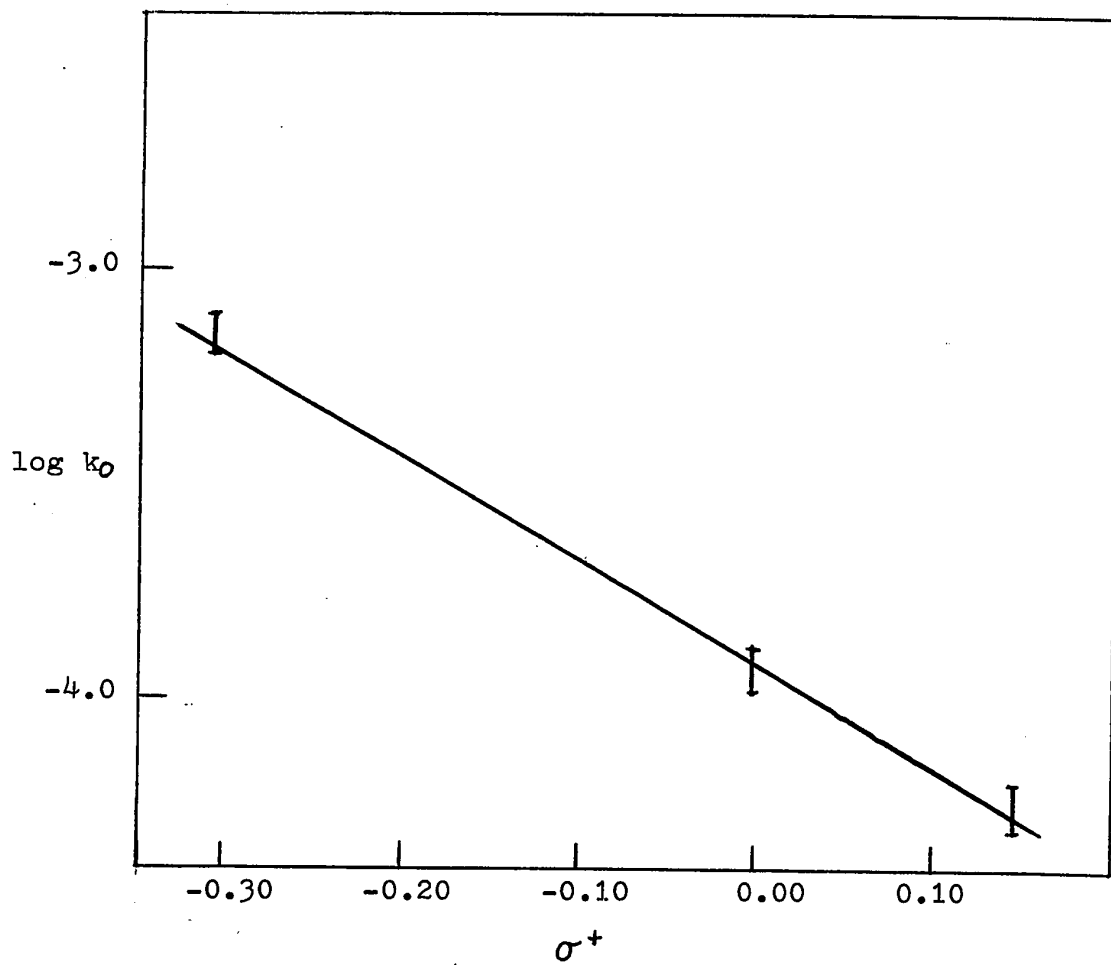

Fig. 23. Plot of  $\log k_0$  for the Pyrolysis of S-Methyl para-substituted Neophyl Xanthates at 250°C against  $\sigma^+$  values: -0.306 for p-CH<sub>3</sub> ; 0.00 for p-H ; +0.148 for p-Br.

of S-methyl 2,2-diphenylpropyl xanthate if statistics was the only controlling factor. Experimentally, the ratio is 1 : 1 if isomerization of 1-ene to 2-ene is not important under the reaction conditions. Again, the result indicates that both statistic and thermodynamic effects are important during the olefin formation process. On the other hand, if all the methyl-trans-stilbene formed were considered to come from the isomerization of 1-benzylstyrene, the 1-ene to 2-ene ratio is 3 : 2. This ratio agrees with the statistically predicted value. In this case the thermodynamic effect may be offset by the repulsive bulky cis phenyl groups in the formation of methyl-cis-stilbene. However, the reasons for the predominant formation of methyl-cis-stilbene over that of the trans isomer is not clear. Perhaps the anion has a preference for abstraction of a proton from the least hindered side (Fig. 24).

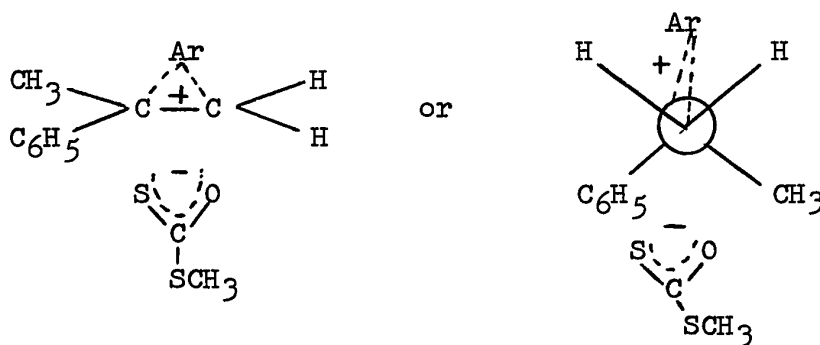
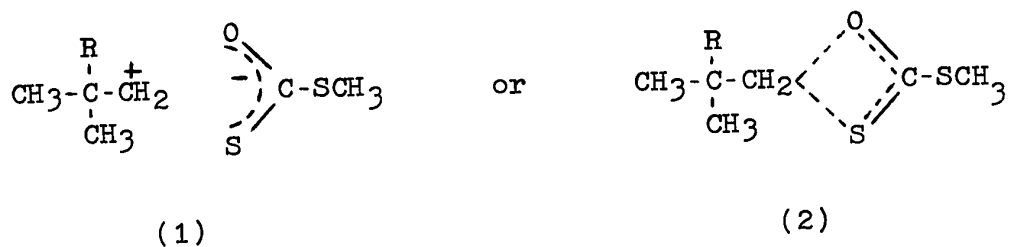

Fig. 24. The Proposed Transition State of the Pyrolysis of S-Methyl Diphenylpropyl Xanthate.

### Dithiolcarbonate Formation

In the xanthate-dithiolcarbonate rearrangement, neopentyl and neophyl xanthate gave the corresponding dithiolcarbonates. The lack of formation of any skeletal rearranged dithiolcarbonate indicated that the rearrangement might have proceeded through a nonassisted tight ion-pair or a classic cyclic S<sub>N</sub>1 mechanism as shown in Figure 25.



R = CH<sub>3</sub>, Aryl.

Fig. 25. The Possible Transition State of the Xanthate-Dithiolcarbonate Rearrangement.

In the first case, electron donating groups at the tertiary carbon seem to stabilize the ion-pair while electron withdrawing groups tend to destabilize it. Thus it is expected that the rate of rearrangement would be faster when R = CH<sub>3</sub> than when R = Aryl. On the contrary, the rate of formation of neophyl dithiolcarbonate was almost nine times faster than that of the neopentyl dithiolcarbonate as shown in Table IV. Therefore a mechanism involving the formation of a nonassisted tight ion-pair intermediate during the xanthate-dithiolcarbonate rearrangement appears to be in contradiction to the observed results. On the other hand localized charge development is not very

important in the concerted transition state (Fig. 25). However electron withdrawing groups at the tertiary carbon atom will enhance the electrophilicity of the methylene group, thus increasing the rate of rearrangement. This allows for the observed faster rate of neophyl dithiolcarbonate formation than that of neopentyl dithiolcarbonate. Moreover, a similar rate of formation of p-bromoneophyl dithiolcarbonate to that of the neophyl dithiolcarbonate also supports the cyclic transition state. Therefore, the mechanism of the dithiolcarbonate formation may be best represented by a concerted four-membered cyclic transition state (Fig. 25 (2)).

#### Summary and Conclusions

The olefin formation and the dithiolcarbonate formation are found to be two competing processes. The Wagner-Meerwein rearrangement becomes more important when the number of beta-phenyl groups increases and when there is an electron donating group at the para-position of the beta-phenyl group. The transition state of the olefin formation process is best represented by a stabilized phenonium ion. The driving force of the rearrangement appears to be mainly electronic in nature, however, release of steric strain could also play an important role. The dithiolcarbonates are thermally more stable than the corresponding xanthates and their formation becomes more important when there is the least beta-phenyl substitution. This rearrangement appears to proceed through a concerted four-membered cyclic transition state.

CHAPTER IIIEXPERIMENTAL

All melting points were taken on a Fisher-John apparatus and are uncorrected. All decomposition points were determined with a CENCO electrothermal melting apparatus. Refractive indices were measured with a Carl Zeiss refractometer at ambient temperature. The infrared (ir) spectra were obtained on Beckman IR-10 and IR-12 spectrophotometers and all ir absorptions are reported in wavenumbers ( $\text{cm}^{-1}$ ). The abbreviations s, m and w used to describe the intensities of the ir bands, stand for strong, medium and weak, respectively. The nuclear magnetic resonance (nmr) spectra were recorded in a JEOLCO JNM-C60 HL instrument and the chemical shifts are reported in  $\delta$  units relative to tetramethylsilane. The abbreviations s, bs, d, bd, t and m to describe the bands stand for singlet, broad singlet, doublet, broad doublet, triplet and multiplet. Gas liquid chromatographic (glc) analyses were carried out on an Hewlett Packard (F and M) Model 720 instrument. The relative peak areas were estimated by means of a disc integrator. Thin layer chromatography (tlc) was performed on alumina or silica gel sheets with fluorescent indicator. Liquid column chromatography (lcc) was performed on a 350 X 25 mm column of Fisher certified neutral alumina, Brockman Activity 1 (80-200 mesh). The elemental analyses were carried out by Midwest Microlab Inc., 6000 East 46th St., Indianapolis Indiana.

S-Methyl Neopentyl Xanthate - The xanthate was prepared according to the method of Ottenbrite.<sup>18</sup> Neopentyl alcohol (44g, 0.5 mole) in dry benzene (250 ml) was reacted with potassium (19.5 g, 0.5 mole) under nitrogen. This solution was refluxed until all of the potassium dissolved, then diluted to one litre by addition of anhydrous ether. A solution of carbon disulphide (50 g, 0.7 mole) in ether was added dropwise at room temperature. This mixture was allowed to stir overnight. The potassium salt of the xanthate was separated by filtration and washed thoroughly with anhydrous ether to remove any of the unreacted alcohol. The salt was suspended in a solution of hexane (500 ml) containing methyl iodide (71 g, 0.5 mole). The potassium iodide was removed by filtration after the mixture was stirred overnight at room temperature. Fractional distillation yielded pure neopentyl xanthate 63 g (70%): bp 81°C at 3.5 mm;  $n_D^{25}$  1.5163; ir (10%, CCl<sub>4</sub>) 2962 and 2872 (s, C-H), 1368 (s, C-H), 1200 (s, C-O-C), 1074 (s, C=S); nmr (10%, CDCl<sub>3</sub>) 1.00 (s, 9, C(CH<sub>3</sub>)<sub>3</sub>), 2.52 (s, 3, SCH<sub>3</sub>), 4.19 (s, 2, OCH<sub>2</sub>).

Anal.	Calcd. for C <sub>7</sub> H <sub>14</sub> OS <sub>2</sub> :	C, 47.15; H, 7.91.
	Found	: C, 47.11; H, 8.16.

Neophyl Alcohol - The alcohol was prepared according to the method of Whitmore.<sup>34</sup> Oxidation of the Grignard reagent of neophyl chloride (168 g, 1.0 mole) which was prepared from methallyl chloride, benzene and concentrated sulphuric acid gave neophyl alcohol 120 g (80%): bp 92°C at 4.0 mm;  $n_D^{21}$  1.5256 (lit.<sup>35</sup> bp 131°C at 30 mm;  $n_D^{20}$  1.5261).

S-Methyl Neophyl Xanthate - By the usual method, S- methyl neophyl xanthate was prepared from neophyl alcohol (30 g, 0.2 mole), potassium (7.8 g, 0.2 mole), carbon disulphide (1.6 g, 0.2 mole) and methyl iodide (28 g, 0.2 mole) and the product weighed 42 g (88%): bp 105°C at 0.17 mm;  $n_D^{21}$  1.5862;  $n_D^{25.5}$  1.5818; ir (10%, CCl<sub>4</sub>) 3060 (m, Ar-H), 2970 and 2872 (s, C-H), 1600 and 1494 (w, Ar), 1360 (m, C-H), 1200 (s, C-O-C), 1070 (s, C=S); nmr (10%, CDCl<sub>3</sub>) 1.35 (s, 6, C(CH<sub>3</sub>)<sub>2</sub>), 2.40 (s, 3, SCH<sub>3</sub>), 4.60 (s, 2, OCH<sub>2</sub>), 7.27 (bs, 5, C<sub>6</sub>H<sub>5</sub>).

Anal.	Calcd. for C <sub>12</sub> H <sub>16</sub> OS <sub>2</sub>	: C, 59.86; H, 6.71.
	Found	: C, 60.08; H, 6.73.

p-Methylneophyl Alcohol - The alcohol was prepared according to the method of Whitmore.<sup>34</sup> Oxidation of the Grignard reagent of p-methylneophyl chloride (107 g, 0.59 mole) which was prepared from methallyl chloride, toluene and concentrated sulphuric acid gave p-methylneophyl alcohol 68 g (70%): bp 88-90°C at 1.5 mm;  $n_D^{25}$  1.5205 (lit.<sup>34</sup> bp 87-88°C at 1.5 mm;  $n_D^{25}$  1.5193).

S-Methyl p-Methylneophyl Xanthate - By the usual method, the xanthate was prepared from p-methylneophyl alcohol (68 g, 0.42 mole), potassium (16 g, 0.42 mole), carbon disulphide (32 g, 0.42 mole) and methyl iodide (59 g, 0.42 mole). After vacuum distillation, the xanthate weighed 93 g (88%): bp 121-122°C at 0.3 mm;  $n_D^{26}$  1.5758; ir (10%, CH Cl<sub>3</sub>) 3020 (m, Ar-H), 2980 and 2872 (s, C-H), 1600 (w, Ar), 1370 (m, C-H), 1210 (s, C-O-C), 1075 (s, C=S); nmr (10%, CDCl<sub>3</sub>) 1.38 (s, 6, C(CH<sub>3</sub>)<sub>2</sub>),



2.28 (s, 3, ArCH<sub>3</sub>), 2.38 (s, 3, SCH<sub>3</sub>), 4.58 (s, 2, OCH<sub>2</sub>), 7.20 (bd, 4, C<sub>6</sub>H<sub>4</sub>).

Anal.	Calcd. for C <sub>13</sub> H <sub>18</sub> OS <sub>2</sub> :	C, 61.37; H, 7.13.
	Found	: C, 61.65; H, 6.88.

p-Bromoneophyl Alcohol - The alcohol was prepared according to the method of Winstein and Heck<sup>30</sup> with modification. 2,2-Dimethylphenylacetonitrile (118 g, 82%) was prepared according to the method of Hauser.<sup>28</sup> Base-catalyzed hydrolysis (potassium hydroxide, 130 g, 2.3 mole; methanol 100 ml; water 40 ml) of the nitrile (118 g, 0.82 mole) at 110°C with vigorous stirring for 1 h gave an almost quantitative yield of the corresponding acid (133 g, 99%). A mixture of the 2-phenylisobutyric acid (130 g, 0.79 mole), bromine (135 g, 0.85 mole) and iron wire (0.2 g) in 150 ml carbon tetrachloride was refluxed overnight. After cooling, the solution was washed with cold 6N hydrochloric acid and then water. The product was extracted with a solution of 50 g of sodium hydroxide in 500 ml of water. Acidification of the extract and cooling gave rise to the crude acid. After drying overnight, the acid weighed 143 g (74%). Lithium aluminum hydride reduction of the acid gave the alcohol. Vacuum distillation yielded pure p-bromoneophyl alcohol 91 g (80%): 114-115°C at 0.05 mm;  $n_D^{25}$  1.5586 (lit.<sup>30</sup> bp 120-123°C at 2.0 mm;  $n_D^{25}$  1.5598).

S-Methyl p-Bromoneophyl Xanthate - By the usual method, the alcohol was reacted sequentially with potassium, carbon disulfide and methyl iodide. However, a multicomponent product

was obtained as shown by tlc analysis (silica gel, benzene). Another attempt was made to synthesize the xanthate by using sodium hydride instead of potassium metal. After all the oil free sodium hydride (1.0 g, 42 mmole) was reacted with p-bromoneophyl alcohol (9.4 g, 41 mmole) in 50 ml ether at  $-20^{\circ}\text{C}$ , followed by the addition of carbon disulphide (3.6 g, 50 mmole) and then methyl iodide (5.9 g, 50 mmole), S-methyl p-bromo-neophyl xanthate was obtained 12.5 g (95%). The xanthate was purified by vacuum distillation: bp  $134-135^{\circ}\text{C}$  at 0.1 mm;  $n_{\text{D}}^{25}$  1.6039; ir (10%,  $\text{CCl}_4$ ) 3020 (m, Ar-H), 2980 and 2870 (s, C-H), 1600 (w, Ar), 1370 and 1365 (m, C-H), 1210 (s, C-O-C), 1075 (s, C=S); nmr (10%,  $\text{CDCl}_3$ ) 1.38 (s, 6,  $\text{C}(\text{CH}_3)_2$ ), 2.42 (s, 3,  $\text{SCH}_3$ ), 4.48 (s, 2,  $\text{OCH}_2$ ), 7.30 (bd, 4,  $\text{C}_6\text{H}_4$ ).

Anal. Calcd. for  $\text{C}_{12}\text{H}_{15}\text{OS}_2\text{Br}$  : C, 45.14; H, 4.74; Br, 25.01.  
 Found : C, 45.46; H, 4.87; Br, 25.04.

2,2-Diphenylpropanol - A suspension of lithium aluminum hydride (4.1 g, 0.11 mole) in 100 ml ether was prepared in a 500-ml, two-necked, round-bottomed flask which was fitted with a reflux condenser, a magnetic stirrer and an externally applied heating mantle. To this suspension was added a solution of 2,2-diphenylpropionic acid (25 g, 0.11 mole) in 50 ml tetrahydrofuran and 50 ml ether. The addition was completed and the solution was refluxed overnight. The excess lithium aluminum hydride was destroyed by the slow addition of 6 N hydrochloric acid at  $0^{\circ}\text{C}$ . The reaction mixture was poured into 500ml of cold water. A stream of air was directed over the stirred

mixture for a period of 14 h. After ether extraction, the organic layer was separated, washed with water and concentrated in vacuo. Vacuum distillation gave pure 2,2-diphenylpropanol 19 g (83%): bp 180-181°C at 1.2 cm (lit.<sup>35</sup> bp 186-187°C at 1.6 cm).

S-Methyl 2,2-Diphenylpropyl Xanthate - By the usual method, the xanthate was prepared from 2,2-diphenylpropanol (2.11 g, 0.1 mole), potassium (3.9 g, 0.1 mole), carbon disulphide (7.6 g, 0.1 mole) and methyl iodide (14.2 g, 0.1 mole). Recrystallization from pentane gave the pure xanthate 16 g (55%): mp 52-53°C; ir (10%, CCl<sub>4</sub>) 3060 (m, Ar-H), 2970 (m, C-H), 1600 and 1490 (w, Ar), 1200 (s, C-O-C), 1070 (s, C=S); nmr (10%, CDCl<sub>3</sub>) 1.75 (s, 3, CCH<sub>3</sub>), 2.30 (s, 3, SCH<sub>3</sub>), 4.85 (s, 2, OCH<sub>2</sub>), 7.02 (s, 10, C(C<sub>6</sub>H<sub>5</sub>)<sub>2</sub> ).

Anal.	Calcd. for C <sub>17</sub> H <sub>18</sub> OS <sub>2</sub>	: C, 67.51; H, 6.00.
	Found	: C, 67.34; H, 5.99.

Triphenylacetic Acid - Excess Dry Ice was added to an ethereal solution of triphenylmethanesodium (0.36 mole) at -40°C. After warming up to 25°C, the sodium salt of triphenylacetic acid was extracted with ether saturated with water. The extract was acidified with 6N hydrochloric acid. The triphenylacetic acid precipitated and was collected by filtration. Recrystallization from acetone-water gave pure triphenylacetic acid 74 g (72%): mp 273-274°C (lit.<sup>36</sup> mp 267-268°C).

2,2,2-Triphenylethanol - The triphenylacetic acid (37 g, 0.13 mole) was reduced with lithium aluminum hydride (14 g, 0.38 mole) by the usual method. Recrystallization from petroleum-ether (bp 66-75°C) gave pure 2,2,2-triphenylethanol 29 g (82%): mp 105-106°C (lit.<sup>37</sup> 109-110°C).

S-Methyl 2,2,2-Triphenylethyl Xanthate - By the usual method, the xanthate was prepared from 2,2,2-triphenylethanol (8 g, 29 mmole), potassium (1.1 g, 29 mmole), carbon disulphide (3 g, 40 mmole) and methyl iodide (4 g, 29 mmole). Recrystallization from petroleum-ether (bp 66-75°C) yielded the pure xanthate 5 g (48%): mp 97-98°C; ir (10%, CCl<sub>4</sub>) 3060 (m, Ar-H), 2910 (m, C-H), 1600 and 1490 (m, Ar), 1210 (s, C-O-C), 1080 (s, C=S); nmr (10%, CDCl<sub>3</sub>) 2.09 (s, 3, SCH<sub>3</sub>), 5.40 (s, 2, OCH<sub>2</sub>), 7.06 (bs, 15, C(C<sub>6</sub>H<sub>5</sub>)<sub>3</sub>).

Anal.	Calcd. for	C <sub>22</sub> H <sub>20</sub> OS <sub>2</sub>	: C, 72.49; H, 5.53.
	Found		: C, 72.15; H, 5.41.

Pyrolysis of S-Methyl Neopentyl Xanthate - S-Methyl neopentyl xanthate (5 g) was refluxed under nitrogen for 48 h. No decomposition was observed as the ir spectrum of the product was identical with S-methyl neopentyl xanthate. Another attempted decomposition was carried out in sealed tube at higher temperature. The xanthate 1 g was sealed in a 4 ml micro test tube under nitrogen and was kept at 270°C for 5 h. The product was analyzed by glc (8 ft Lac-728 column, 120°C, 60 cc helium / min) and gave two peaks. The first peak (ret. time,

32 min; 60%) was identified as the unreacted S-methyl neopentyl xanthate. The second peak (ret. time 38 min; 40%) was identified as the S-methyl neopentyl dithiolcarbonate: ir (10%,  $\text{CCl}_4$ ) 2960 and 2870 (s, C-H), 1650 (s, C=O), 1365 (m, C-H), 860 (s, S-CO-S); nmr (10%,  $\text{CDCl}_3$ ) 0.97 (s, 9,  $\text{C}(\text{CH}_3)_3$ ), 2.48 (s, 3,  $\text{SCH}_3$ ), 3.07 (s, 2,  $\text{SCH}_2$ ).

In an attempt to detect olefin formation, this xanthate (200 mg) was sealed in a nmr tube and heated in a silicone oil bath at  $250^\circ\text{C}$ . A spectrum was run every 4 h. After forty hours no olefin was observed and the corresponding dithiolcarbonate was the only product in 42% yield.

Pyrolysis of S-Methyl Neopentyl Dithiolcarbonate - The dithiolcarbonate (200 mg) in a sealed nmr tube was kept in a silicone oil bath at  $250^\circ\text{C}$ . A nmr spectrum was run every 10 h. After a duration of 40 h, no decomposition was observed. The ir spectrum of the resultant liquid was identical to that of the starting dithiolcarbonate.

Pyrolysis of S-Methyl Neophyl Xanthate - Decomposition of a small amount of the xanthate (0.5 g, 2.1 mmole) was carried out with a N-tube (Fig. 26) in a silicone oil bath at  $250^\circ\text{C}$ .

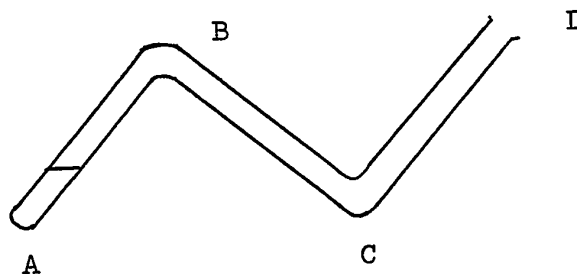

Fig. 26. A N-tube for Pyrolysis.

The xanthate was pipetted into a straight tube AD about 12 cm long which then was bent as shown in Figure 26. Part A of the tube was immersed in the oil bath while part C was cooled. The advantage of this N-tube is that the free vapour volume is minimized allowing a smaller amount of xanthate to be studied with no losses. After heating for 2 h part A was cooled and part B was cut for the convenience of manipulation. The olefins from part C of the tube weighed 120 mg (45%) while the residue from part A weighed 270 mg.

Analysis of the Olefins - The olefins were separated by glc (8 ft. Lac-728 column, 125°C, 60 cc helium / min). On the chromatograph two peaks appeared at 5.5 min (67%), and 7.5 min (33%). The first peak was identified as 2-benzylpropene:  $n_D^{25}$  1.5050 (lit.<sup>30</sup> 1.5057); ir (10%, CCl<sub>4</sub>) 3080 (s, C=CH), 3020 (s, Ar-H), 2980 and 2970 (s, C-H), 1645 (m, C=C), 1600 and 1490 (w, Ar), 884 (s, C=CH<sub>2</sub>), 690 (s, Ar-H); nmr (10%, CDCl<sub>3</sub>) 1.65 (s, 3, C=CCH<sub>3</sub>), 3.24 (s, 2, C=C-CH<sub>2</sub>-Ar), 4.62 (s, 2, C=CH<sub>2</sub>), 7.00 (bs, 5, C<sub>6</sub>H<sub>5</sub>). The second peak was identified as 2-methyl-1-phenylpropene:  $n_D^{25}$  1.5367 (lit.<sup>34</sup>  $n_D^{20}$  1.5400); ir (10%, CCl<sub>4</sub>) 3060 (s, C=CH), 3020 (s, Ar-H), 2970 and 2920 (s, C-H), 1659 (m, C=C), 1600 and 1490 (w, Ar), 825 (m, C=CH), 690 (s, Ar-H); nmr (10%, CDCl<sub>3</sub>) 1.85 (m, 6, C=C(CH<sub>3</sub>)<sub>2</sub>), 6.10 (m, 1, C=CH), 7.07 (bs, 5, C<sub>6</sub>H<sub>5</sub>).

Analysis of the olefinic mixture by nmr integration showed a similar product distribution.

Isomerization Study of the Olefins - A 30 mg sample of each of the two olefins was heated separately in a N-tube at 250°C for 30 min. The nmr spectrum showed that no isomerization occurred for both 2-benzylpropene and 2-methyl-1-phenylpropene.

Analysis of the Residue - The residue was separated by glc (6 ft Lac-728 column, 200°C, 60 cc helium / min). On the chromatograph only two peaks appeared at 130 min (60%), and at 138 min (40%). The compound corresponding to the first peak was identical to the unreacted xanthate. The second component of the residue was identified as the S-methyl neophyl dithiolcarbonate:  $n_D^{26}$  1.5757; ir (10%, CCl<sub>4</sub>) 3020 (w, Ar-H), 2950 and 2920 (s, C-H), 1640 (s, C=O), 860 (s, S-CO-S), 690 (s, Ar-H); nmr (10%, CDCl<sub>3</sub>) 1.34 (s, 6, C(CH<sub>3</sub>)<sub>2</sub>), 2.28 (s, 3, SCH<sub>3</sub>), 3.20 (s, 2, SCH<sub>2</sub>), 7.00 (bs, 5, C<sub>6</sub>H<sub>5</sub>).

Analysis of the residue by nmr integration showed a similar product distribution.

Hydrolysis and Reduction of the Dithiolcarbonate - The dithiolcarbonate (1 g) was hydrolyzed by sodium hydroxide according to the method of Taguchi and co-workers<sup>23</sup> followed by Ra-Ni reduction according to the method of Sonheimer and Rosenthal<sup>38</sup>. The resulting reaction mixture was extracted with ether. The organic layer was concentrated and analyzed by glc, ir and nmr. Tert-butylbenzene was the only observed product.

Another xanthate sample (500 mg) was prepared in a N-tube and was heated for 30 min. The olefins weighed 42 mg (16%) and nmr integration showed that the 1-ene and the 2-ene were present in the ratio 67 : 33. The residue weighed 412 mg and the nmr integration showed that the xanthate to the dithiolcarbonate ratio was 90 : 10.

Pyrolysis of S-Methyl Neophyl Dithiolcarbonate - The dithiolcarbonate (22 mg) was heated in a N-tube at 250°C for 2 h. No olefin was found. The residue was analyzed by glc, ir and nmr and was found to be the starting dithiolcarbonate.

Pyrolysis of S-Methyl p-Bromoneophyl Xanthate - Decomposition of the xanthate (41 mg, 0.13 mmole) was carried out in a 75 X 10 mm test tube at 250°C for 2 h. The relative amounts of products were analyzed by nmr integration without separation (methyl benzoate as internal standard). The mixture contained 50% of the unreacted xanthate and 17% of the dithiolcarbonate. The olefinic portion was not analyzed.

Pyrolysis of S-Methyl p-Methylneophyl Xanthate - Decomposition of the xanthate (33 mg, 0.13 mmole) was carried out in a 75 X 10 mm test tube at 250°C for 30 min. The relative amount of products were analyzed by nmr integration without separation (methyl benzoate as internal standard). The mixture contained 27% of the unreacted xanthate and less than 4% of the dithiolcarbonate. The olefin portion was not analyzed.



Pyrolysis of S-Methyl 2,2-Diphenylpropyl Xanthate -

Decomposition of the xanthate (500 mg, 1.65 mmole) was carried out in a N-tube in a silicone oil bath at 250°C for 30 min. No olefin was found in part C of the tube. The residue was analyzed in the following manner.

Analysis of Olefins - The olefins were separated from the residue by lcc (silica gel, petroleum ether (bp 30-60°C) ) and weighed 280 mg (88%). Olefins were further separated by glc (6 ft 10 % SE-30, 170°C, 60 cc helium / min). On the chromatograph, three peaks appeared [6.4 min (39%), 7.4 min (49%), 10.8 min (12%)]. Analysis of the olefinic mixture by nmr integration showed a similar product distribution. The first peak was identified as methyl-cis-stilbene: mp 46-47°C (lit.<sup>39</sup> mp 48°C); ir (10%, CCl<sub>4</sub>) 3060 (s, C=CH), 3020 (s, Ar-H), 2970 and 2920 (w, C-H), 1600 and 1490 (m, Ar), 849 (m, C=CH), 690 (s, Ar-H); nmr (10%, CCl<sub>4</sub>) 2.11 (d, 3, J=2c/s, C=CCH<sub>3</sub>), 6.21 (m, 1, C=CH), 6.70-7.10 (bd, 10, C(C<sub>6</sub>H<sub>5</sub>)<sub>2</sub> ). The second peak was identified as 1-benzylstyrene:  $n_D^{24}$  1.5893 (lit.<sup>40</sup>  $n_D^{25}$  1.5891); ir (10%, CCl<sub>4</sub>) 3060 (s, C=CH), 3020 (s, Ar-H), 2910 (m, C-H), 1625 (m, C=C), 1600 and 1490 (m, Ar), 890 (s, C=CH<sub>2</sub>), 690 (s, Ar-H); nmr (10%, CCl<sub>4</sub>) 3.65 (s, 2, C=CCH<sub>2</sub>Ar), 4.80 (bd, 1, C=CH), 5.25 (bd, 1, C=CH), 6.90-7.10 (bs, 10, C(C<sub>6</sub>H<sub>5</sub>)<sub>2</sub> ). The third peak was identified as methyl-trans-stilbene: mp 81-82°C (lit.<sup>39</sup> mp 82°C); ir (10%, CCl<sub>4</sub>) 3060 (s, C=CH), 3020 (s, Ar-H), 2980 and 2940 (w, C-H), 1600 and 1490 (m, Ar), 849 (m, C=CH), 690 (s, Ar-H); nmr (10%, CCl<sub>4</sub>)

2.17 (d, 3,  $J=2c/s$ ,  $C=CCH_3$ ), 6.65 (m, 1,  $C=CH$ ), 6.90-7.20 (m, 10,  $C(C_6H_5)_2$  ).

Olefin Isomerization Study - A 30 mg sample of each of the latter three product olefins was heated separately in three micro test tube at  $250^\circ C$  for 30 min. The nmr spectrum showed that no isomerization occurred for both trans- and cis-stilbenes. However, 48% of benzylstyrene was isomerized to methyl-trans-stilbene.

Analysis of the Residue - The residue was separated by lcc and it weighed 60 mg. The ir spectrum showed the characteristic xanthate bands and dithiolcarbonate bands at  $1645\text{ cm}^{-1}$  and  $860\text{ cm}^{-1}$ . The nmr spectrum showed that the residue contained 66% of the unreacted xanthate. Attempts to isolate the dithiolcarbonate were unsuccessful.

Pyrolysis of S-Methyl 2,2,2-Triphenylethyl Xanthate - Decomposition of the xanthate (1 g) was carried out in a micro test tube in a silicone oil bath at  $250^\circ C$  for 30 min. The product weighed 700 mg. The tlc analysis (silica gel, pentane) showed only one spot corresponding to triphenylethylene: mp  $88-89^\circ C$ . The ir spectrum was identical to an authentic sample.

An Attempt to Detect Dithiolcarbonate Formation - The S-methyl xanthate ester of 2,2,2-triphenylethanol (0.5 g) in a nmr tube was heated in a silicone oil bath at  $200^\circ C$ . A nmr spectrum was run every 30 min for a period of 2 h. No dithiolcarbonate

signal was observed. Another sample was heated in an oil bath at 160°C. A nmr spectrum was run every 6 h for a period of 36 h. Again, no dithiolcarbonate signal was observed.

Kinetic Studies - Kinetic studies of the pyrolysis of xanthate esters were carried out on neat samples. An accurately weighed sample (30 mg) of the solid xanthate ester to be studied was placed in a 75 X 10 mm test tube. For the case of a liquid xanthate ester, a 30  $\mu$ l sample was introduced into the test tubes by means of a constant volume addition syringe and then it was weighed accurately. The test tubes were loosely corked or sealed under a nitrogen atmosphere and were suspended in a constant temperature silicone oil bath at the desired temperature using a Haake N-series circulator. Samples were removed at set intervals and were immediately cooled in ice-water. The samples were analyzed by nmr with methyl benzoate as the internal standard. The relative amount of xanthate left and the relative amount of products formed were estimated from three nmr integrations of each sample. The integrated ratio varied by 5 %. The experimental data are shown in Table VI to XIV.

Table VI

Pyrolysis of S-Methyl Neopentyl Xanthate at  $250 \pm 1^\circ \text{C}$ .Weight of Xanthate [X] = 30.8 mg  $\pm$  0.2 mg.Weight of Benzoate [S] = 9.7 mg  $\pm$  0.1 mg.

	Time (hour)	$[X]/[S]$	$[X_0]/[X]$	$[D]/[S]$	$[D]/[X_0]$	$1 - [D]/[X_0]$
0	0.00	2.42	1.00	0.00	0.00	1.00
1	2.00	2.24	1.08			
2	4.00	2.14	1.13	0.16	0.07	0.93
3	6.00	2.08	1.16	0.27	0.11	0.89
4	8.00	1.79	1.35	0.30	0.12	0.87
5	10.00	1.91	1.27	0.43	0.18	0.82
6	12.00	1.82	1.33	0.43	0.18	0.82
7	13.92	1.75	1.38	0.58	0.24	0.76
8	15.83	1.70	1.42	0.67	0.28	0.72
9	17.92	1.64	1.48	0.73	0.30	0.70
10	20.00	1.58	1.53	0.87	0.36	0.64
11	22.00	1.48	1.64	0.86	0.35	0.65
12	24.00	1.45	1.67	0.98	0.41	0.59
13	26.00	1.41	1.73	1.07	0.44	0.56
14	28.00	1.31	1.84	1.09	0.45	0.55
15	30.00	1.25	1.93	1.11	0.46	0.54
16	32.00	1.16	2.08	1.17	0.49	0.51
17	36.17	1.09	2.22	1.30	0.54	0.46

Table VII

Pyrolysis of S-Methyl Neophyl Xanthate at  $250 \pm 1^\circ\text{C}$ .Weight of Xanthate [X] = 33.2 mg  $\pm$  0.2 mg.Weight of Benzoate [S] = 7.5 mg  $\pm$  0.1 mg.

	<u>Time (min)</u>	<u>[X]/[S]</u>	<u>[X<sub>0</sub>]/[X]</u>	<u>[X<sub>0</sub>-X]/[S]</u>	<u>[D]/[S]</u>
0	0.0	2.50	1.00	0.00	0.00
1	6.0	2.34	1.07	0.16	
2	12.0	2.24	1.12	0.26	0.09
3	18.0	2.06	1.21	0.44	0.12
4	24.0	1.96	1.28	0.54	0.15
5	30.0				
6	36.0	1.80	1.39	0.70	0.27
7	42.0	1.66	1.52	0.84	0.27
8	50.0				
9	54.0	1.47	1.70	1.03	0.37
10	60.0	1.41	1.77	1.09	0.37
11	66.0	1.31	1.91	1.19	0.38
12	72.0	1.24	2.02	1.26	0.40
13	78.0	1.16	2.06	1.34	0.37
14	84.0	1.12	2.23	1.38	0.43
15	90.0	1.01	2.48	1.49	0.46
16	100.0	0.97	2.58	1.53	0.48
17	110.0	0.85	2.93	1.65	0.49
18	120.0	0.81	3.11	1.69	0.54
19	130.0	0.63	3.98	1.87	0.59
20	140.0	0.66	3.80	1.84	0.60
21	150.0	0.62	4.04	1.88	0.70

Table VIII

Pyrolysis of S-Methyl p-Bromoneophyl Xanthate at  $250 \pm 1^\circ\text{C}$ .Weight of Xanthate [X] =  $40.5 \pm 0.2$  mg.Weight of Benzoate [S] =  $8.6 \pm 0.1$  mg.

	<u>Time (min)</u>	<u>[X]/[S]</u>	<u>[X<sub>0</sub>]/[X]</u>	<u>[X<sub>0</sub>-X]/[S]</u>	<u>[D]/[S]</u>
0	0.0	1.98	1.00	0.00	0.00
1	15.0	1.83	1.08	0.15	0.05
2	30.0	1.74	1.14	0.24	0.11
3	45.0	1.50	1.32	0.48	0.19
4	69.0	1.30	1.52	0.68	0.21
5	84.0	1.26	1.57	0.72	0.25
6	99.0	1.15	1.72	0.83	0.31
7	123.0	1.01	1.96	0.97	0.34
8	143.0	0.82	2.42	1.16	0.35
9	206.0	0.71	2.81	1.28	0.46

Table IX

Pyrolysis of S-Methyl p-Methylneophyl Xanthate at  $250 \pm 1^\circ\text{C}$ .

Weight of Xanthate [X] =  $33.4 \pm 0.2$  mg.

Weight of Benzoate [S] =  $8.6 \pm 0.1$  mg.

	<u>Time (min)</u>	<u>[X]/[S]</u>	<u>[X<sub>0</sub>]/[X]</u>
0	0.0	2.13	1.00
1	3.0	1.95	1.09
2	6.0	1.62	1.31
3	9.0	1.40	1.52
4	12.0	1.30	1.64
5	15.0	1.17	1.82
6	18.0	1.10	1.93
7	21.0	0.88	2.24
8	25.0	0.78	2.74
9	28.0	0.66	3.23
10	31.0	0.58	3.67
11	36.0	0.51	4.17
12	42.0	0.46	4.64

Table X

Pyrolysis of S-Methyl 2,2-Diphenylpropyl Xanthate at  $250 \pm 1^\circ\text{C}$ .

Weight of Xanthate  $[X] = 40.0 \pm 0.5$  mg.

Weight of Benzoate  $[S] = 5.3 \pm 0.1$  mg.

	<u>Time (min)</u>	<u><math>[X]/[S]</math></u>	<u><math>[x_d]/[X]</math></u>
0	0.00	3.39	1.00
1	0.75	3.23	1.05
2	1.50	3.06	1.11
3	2.15	2.77	1.22
4	3.00	2.44	1.39
5	3.45	2.37	1.43
6	4.30	2.25	1.51
7	5.15	2.10	1.61
8	6.00	2.04	1.66
9	6.45	1.94	1.75
10	7.30	1.75	1.94
11	8.15	1.54	2.20
12	9.00	1.48	2.29
13	9.45	1.46	2.28
14	10.30	1.36	2.50
15	11.15	1.26	2.69
16	12.00	1.17	2.90
17	12.45	0.98	3.46
18	13.30		
19	14.15	0.90	3.76
20	15.00	0.88	3.84



Table XI

Pyrolysis of S-Methyl 2,2,2-Triphenylethyl Xanthate at  $174 \pm 1^\circ\text{C}$ .

Weight of Xanthate  $[X] = 40.0 \pm 0.5$  mg.

Weight of Benzoate  $[S] = 5.3 \pm 0.1$  mg.

	<u>Time (hour)</u>	<u><math>[X]/[S]</math></u>	<u><math>[X_0]/[X]</math></u>
0	0.00	2.81	1.00
1	1.50	2.61	1.08
2	3.00	2.26	1.24
3	4.50	2.07	1.36
4	6.00	1.95	1.44
5	7.50	1.67	1.66
6	9.00	1.54	1.82
7	10.50	1.43	1.96
8	12.00	1.34	2.10
9	13.50	1.24	2.26
10	15.00	1.07	2.63
11	16.50	0.95	2.97
12	18.00	0.92	3.06
13	20.50	0.84	3.34
14	21.00	0.79	3.58
15	22.50	0.67	4.20
16	24.00	0.61	4.61
17	25.50	0.64	4.40
18	27.00	0.60	4.47
19	28.50	0.51	5.60
20	30.00	0.44	6.40

Table XII

Pyrolysis of S-Methyl 2,2,2-Triphenylethyl Xanthate at  $185 \pm 1^\circ\text{C}$ .

Weight of Xanthate [X] =  $40.0 \pm 0.5$  mg.

Weight of Benzoate [S] =  $5.3 \pm 0.1$  mg.

	<u>Time (min)</u>	<u>[x]/[s]</u>	<u>[x<sub>0</sub>]/[x]</u>
0	0.0	2.81	1.00
1	30.0	2.58	1.09
2	60.0	2.21	1.27
3	91.0	2.02	1.39
4	121.0	1.92	1.46
5	150.0	1.78	1.58
6	180.0	1.65	1.70
7	210.0	1.50	1.87
8	240.0	1.43	1.96
9	270.0	1.28	2.19
10	300.0	1.18	2.38
11	340.0	1.01	2.78
12	360.0	0.97	2.91
13	390.0	0.90	3.13
14	422.0	0.83	3.38
15	450.0	0.82	3.42
16	480.0	0.76	3.71
17	510.0	0.65	4.31
18	545.0	0.64	4.37
19	570.0	0.68	4.10
20	624.0	0.50	5.70

Table XIII

Pyrolysis of S-Methyl 2,2,2-Triphenylethyl Xanthate at  $200 \pm 1^\circ\text{C}$

Weight of Xanthate  $[X] = 30.0 \pm 0.5$  mg.

Weight of Benzoate  $[S] = 7.0 \pm 0.1$  mg.

	<u>Time (min)</u>	<u><math>[x]/[s]</math></u>	<u><math>[x_o]/[x]</math></u>
0	0.0	1.48	1.00
1	5.0	1.33	1.12
2	10.0	1.30	1.15
3	15.0	1.27	1.18
4	20.0	1.18	1.26
5	25.0	1.17	1.27
6	30.0	1.06	1.39
7	35.0	1.01	1.48
8	40.0	0.94	1.60
9	45.0	0.87	1.71
10	50.0	0.84	1.76
11	55.0	0.77	1.95
12	60.0	0.76	1.96
13	65.0	0.73	2.04
14	70.0	0.70	2.14
15	75.0	0.68	2.18
16	80.0	0.67	2.27
17	90.0	0.61	2.50
18	100.0	0.56	2.48
19	110.0	0.50	3.04

Table XIV

Pyrolysis of S-Methyl 2,2,2-Triphenylethyl Xanthate at  $220 \pm 1^\circ\text{C}$ .

Weight of Xanthate  $[X] = 30.0 \pm 0.5$  mg.

Weight of Benzoate  $[S] = 7.0 \pm 0.1$  mg.

	<u>Time (min)</u>	<u><math>[X]/[S]</math></u>	<u><math>[X_0]/[X]</math></u>
0	0.0	1.48	1.00
1	1.0	1.43	1.04
2	2.0	1.33	1.11
3	3.0	1.19	1.25
4	4.0	1.25	1.18
5	5.0	1.17	1.26
6	6.0	1.06	1.40
7	7.0	0.94	1.51
8	8.0	0.91	1.63
9	9.0	0.88	1.69
10	10.0	0.85	1.74
11	11.0	0.80	1.85
12	12.0	0.75	2.00
13	13.0	0.72	2.06
14	14.0	0.63	2.19
15	15.0	0.61	2.44
16	16.0		
17	18.0	0.55	2.70
18	21.0	0.46	3.22
19	24.0	0.38	3.94

REFERENCE

1. For reviews, see C. H. DePuy and R. W. King, Chem. Revs., 60, 431 (1960); H. R. Nace in "Organic Reactions," Vol. XII, John Wiley and Sons, Inc., New York, N. Y., 1962, p 58.
2. J. March in "Advanced in Organic Chemistry," McGraw Hill, Inc., New York, N. Y., 1968, p 757.
3. G. L. O'Connor and H. R. Nace, J. Amer. Chem. Soc., 75, 2118 (1953).
4. F. F. Bordwell and P. S. Landis, J. Amer. Chem. Soc., 80, 6379 (1958).
5. D. J. Cram, ibid., 71, 3883 (1949).
6. R. F. W. Bader and A. N. Bourns, Can. J. Chem., 39, 348 (1961).
7. I. M. McAlpine, J. Chem. Soc., 1114 (1931).
8. F. C. Whitmore, J. Amer. Chem. Soc., 55, 3809 (1933).
9. F. C. Whitmore, ibid., 55, 3809 (1933).
10. E. T. McBee, J. F. Higgins and O. R. Pierce, ibid., 74, 1387 (1952).
11. W. Hüchel, W. Tappe and G. Legutke, Ann., 543, 191 (1940).
12. L. R. Alexander and A. Mudrack, J. Amer. Chem. Soc., 73, 59 (1951).
13. D. G. Botteron and G. P. Schulman, J. Org. Chem., 27, 2007 (1962).
14. C. Djerassi and W. S. Briggs, ibid., 33, 1625 (1968).
15. E. R. Alexander and A. Mudrack, J. Amer. Chem. Soc., 72, 1810 (1950).

16. R. E. Gilman, J. D. Henion, S. Shakshoski, J. I. H. Patterson, M. J. Bogdanowicz, R. J. Griffith, D. E. Harrington, R. K. Randall and K. T. Finley, Can. J. Chem., 48, 970 (1970).
17. F. G. Bordwell and P. S. Landis, J. Amer. Chem. Soc., 80, 2450 (1958).
18. K. G. Rutherford, R. M. Ottenbrite and B. K. Tang, J. Chem. Soc., (C), 582 (1971).
19. R. M. Ottenbrite, Thesis, University of Windsor, 1966, p 53.
20. J. P. Fackler, W. C. Seidel, S. M. Myron, Chem. Comm., 1133 (1969).
21. N. Burke, D. Bridgeford A. Turbak, Chem. and Eng. News, Sept. 22, 1969, p 41.
22. C. G. Overberger and A. E. Borchert, J. Amer. Chem. Soc., 82, 4896 (1960).
23. T. Taguchi and M. Makao, Tetrahedron, 18, 245 (1962).
24. T. Taguchi, Y. Kawazoe and M. Makao, Tetrahedron Lett., 131 (1963).
25. T. Taguchi, Y. Kawazoe, K. Yoshihira, H. Kanayama, M. Mori, K. Tabata and K. Harano, ibid., 2717 (1965).
26. P. V. Laakso, Suomen Kemi, 13B, 8 (1940); Chem. Abstr., 34, 5059 (1940).
27. P. de Mayo in "Molecular Rearrangements," Vol. I, Interscience, New York, N. Y., 1963, pp 6-15.
28. C. R. Hauser, W. G. Kenyo, J. Org. Chem., 30, 4135 (1965).
29. E. V. Heymingen, J. Amer. Chem. Soc., 74, 4862 (1952).
30. S. Winstein and R. Heck, ibid., 79, 3432 (1957).

31. H. C. Brown, R. Bernheimer and K. J. Morgan, ibid., 87, 1280 (1965).
32. H. Kwart and D. Hoster, Chem. Comm., 1155 (1967).
33. H. Kwart and H. G. Ling, ibid., 302 (1969).
34. F. C. Whitmore, J. Amer. Chem. Soc., 65, 1469 (1943).
35. Faworski and Korolew, Chem. Zentr., 111, 668 (1923).
36. H. A. Smith and R. J. Smith, J. Amer. Chem. Soc., 70, 2400 (1948).
37. Schlenk and Ocks, Ber., 49, 610 (1916).
38. F. Sondheimer and D. Rosenthal, J. Amer. Chem. Soc., 80, 3995 (1958).
39. E. Ellingboe and R. C. Fuson, ibid., 55, 2964 (1933).
40. D. H. Hunter and D. J. Cram, ibid., 88, 5499 (1966).

PART IIISYNTHESIS OF SOME SULPHONYL CHLORIDES  
AS PRECURSORS FOR STABLE SULPHENESCHAPTER IINTRODUCTION

Sulphenes<sup>1</sup> may be considered as the S,S-dioxides of thioketones. They may also be regarded as the derivatives of sulphur trioxide with one oxygen atom being replaced by an alkylidene group. There are four canonical sulphene structures (Fig. 1).

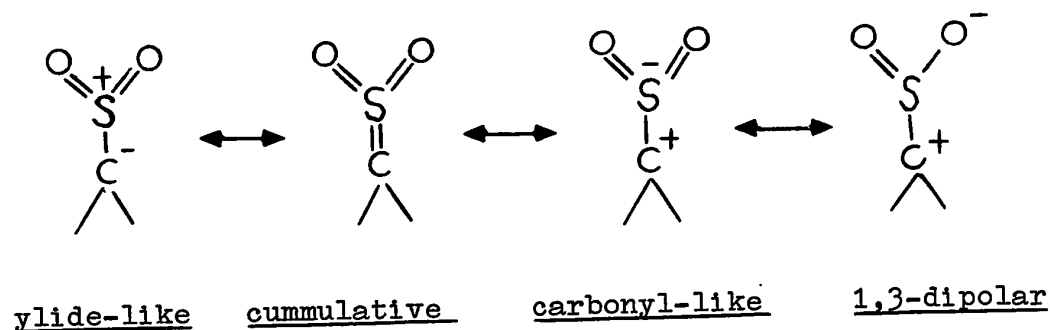

Fig. 1. Canonical Structures of Sulphenes.

By far the most common mode of reaction is that corresponding to the ylide-like structure. Hence, the sulphonyl group exhibits electrophilic characteristics and the alkylidene portion exhibits nucleophilic characteristics. Thus, sulphenes react with deuterated alcohols to form monodeuterated sulphonates,<sup>2</sup> with enamines and ketene O, N- and N, N-acetals



to give four-membered ring sulphones.<sup>4,5</sup> They also react with nitrones to give five-membered ring aza-sultone intermediates.<sup>6</sup> And with dienamines to give six-membered ring sulphones.<sup>7</sup> These reactions are illustrated in Figure 2.

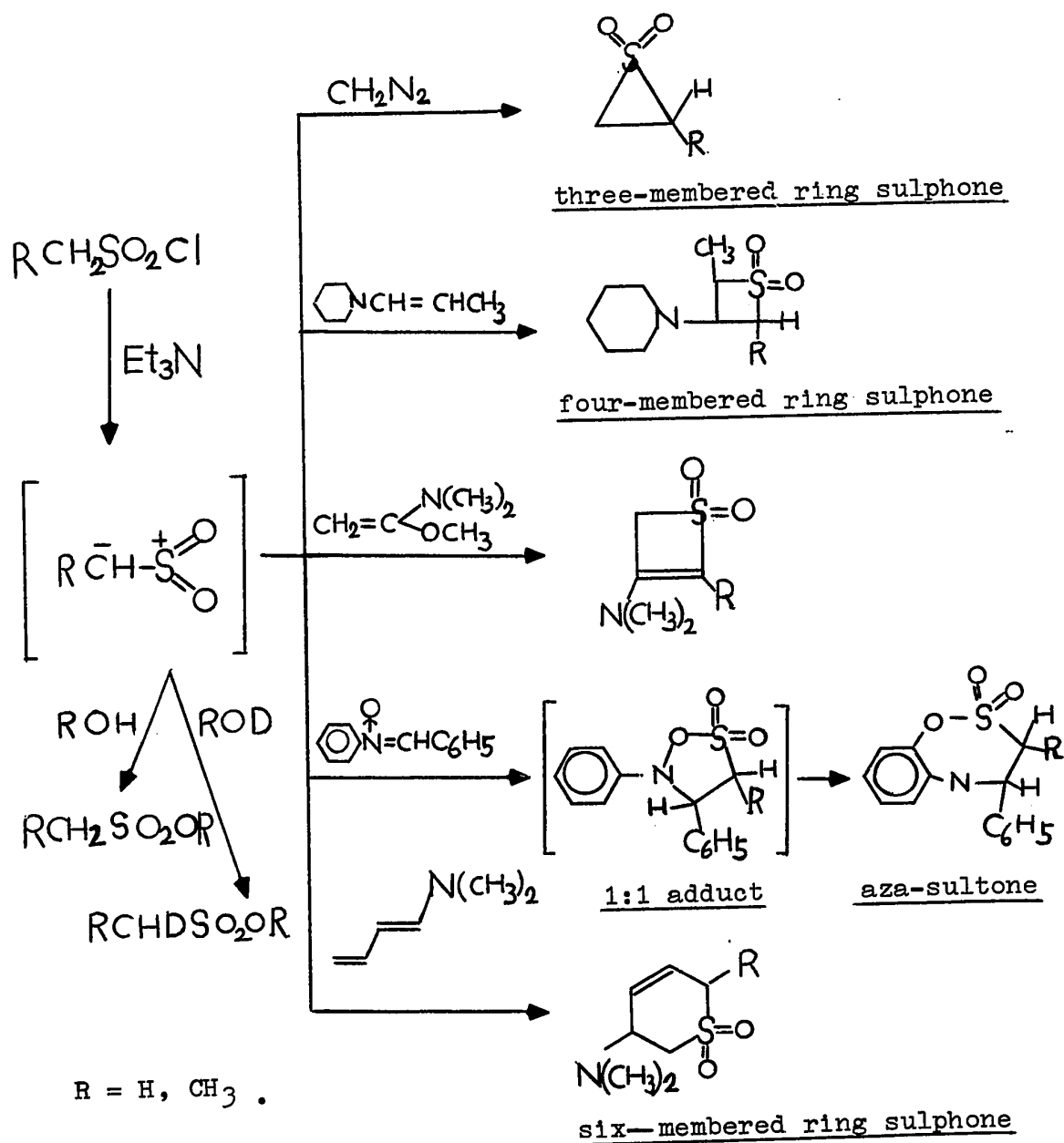

Fig. 2. Ylide-type Reactions of Sulphene Intermediates.

In the absence of trapping reagents, sulphenes react with the starting materials. Thus, the formation of  $\alpha$ -chlorosulphones,  $\alpha$ -chlorodisulphones and  $\alpha$ -chlorotrisulphones was proposed to be the result a continuous 1,2-addition of sulphonyl chloride to the ylide-like sulphene resonance structure followed by a loss of sulphur dioxide (Fig. 3).<sup>8</sup>

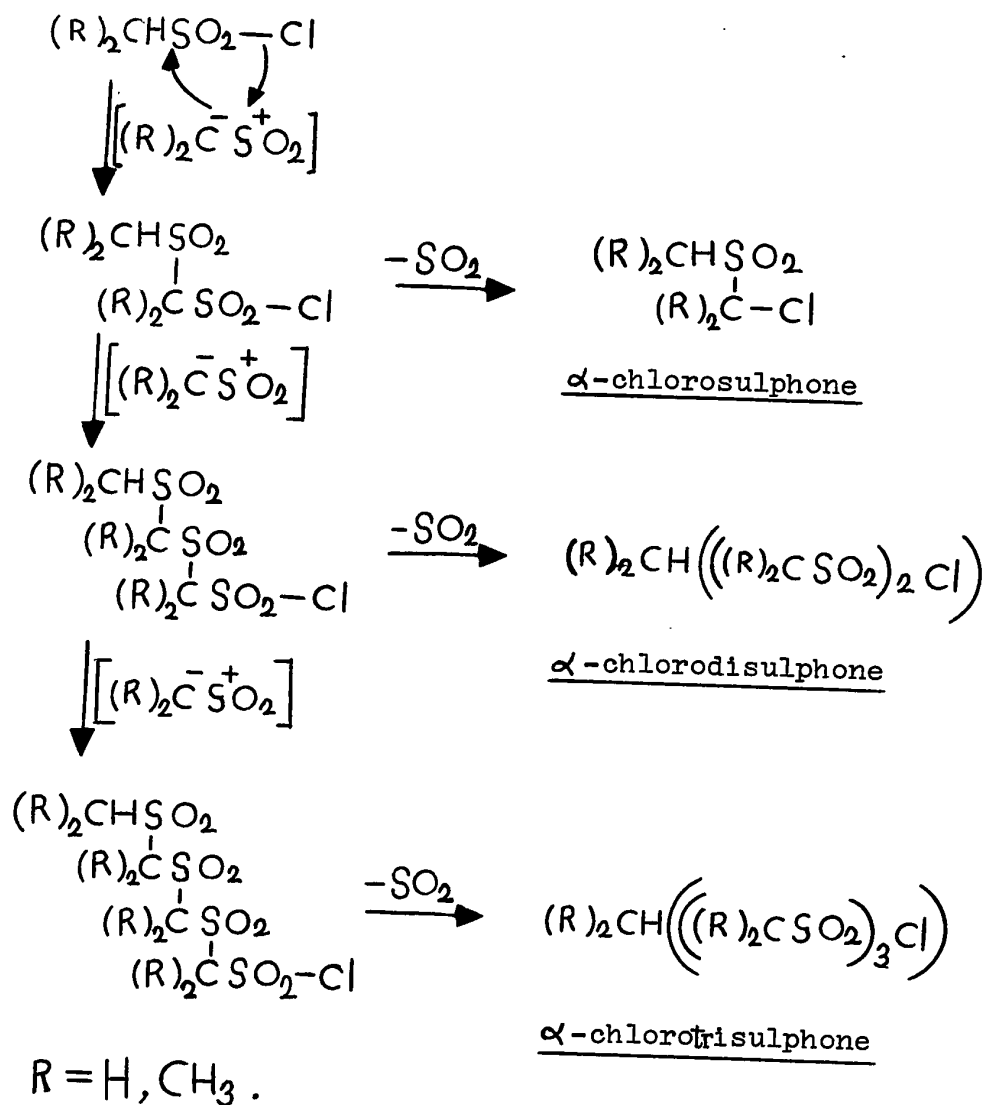

Fig. 3. 1,2-Addition Reactions of Sulphene Intermediates.

The isolation of the mesylsulphene adduct shown in Figure 4 further supported the ylide-like sulphene resonance structure.<sup>9</sup>

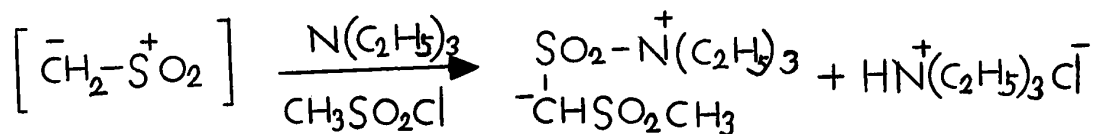

Fig. 4. Formation of Mesylsulphene Adduct.

Besides the ylide-like sulphene resonance structure, both the 1,3-dipolar and carbonyl-like resonance structures have been postulated as reaction species. Thus, Strating<sup>10</sup> proposed a 1,3-dipolar sulphene structure to explain the formation of 10-camphor thiocarbonyl chloride S-oxide (Fig. 5).

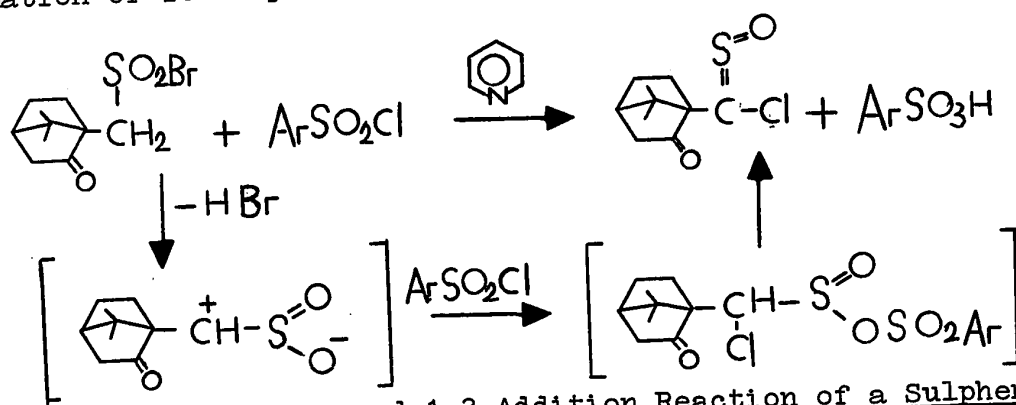

Fig. 5. A Proposed 1,3-Addition Reaction of a Sulphene Intermediate.

In the study of the thermolysis and photolysis of the sultam (I), King and Durst<sup>11</sup> proposed a mechanism involving nucleophilic attack on the sulphene carbon atom to give pyrrole (II) as shown in Figure 6. The authors proposed a carbonyl-like sulphene intermediate to explain the results.

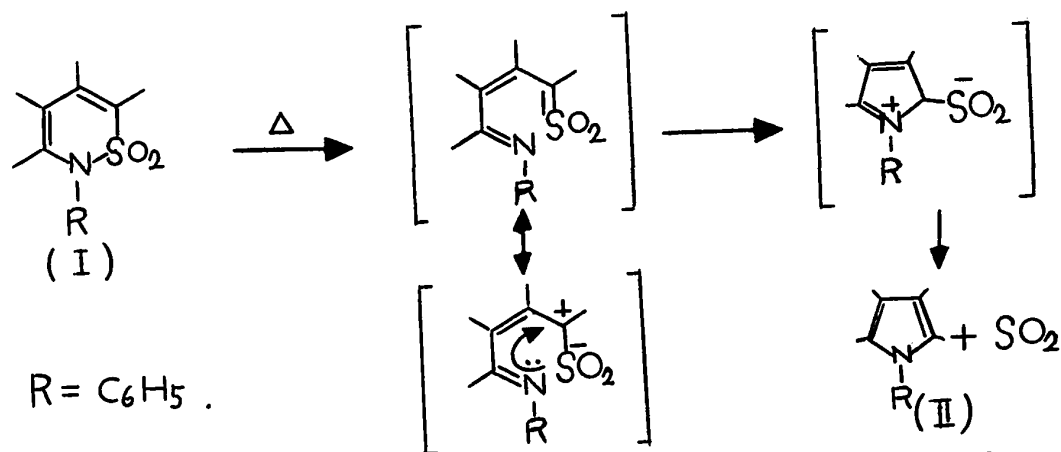

Fig. 6. A Proposed Carbonyl-like Reaction of a Sulphene Intermediate.

The generation of sulphenes can be achieved by several routes. In 1911, Wedekind and Schenk<sup>12</sup> first discovered that triethylamine removes hydrogen chloride from phenylmethane-sulphonyl chloride even in cold benzene. These authors obtained triethylamine hydrochloride, sulphur dioxide and stilbene and concluded that the phenylsulphene intermediate had lost sulphur dioxide and that remaining moiety had dimerized (Fig. 7).

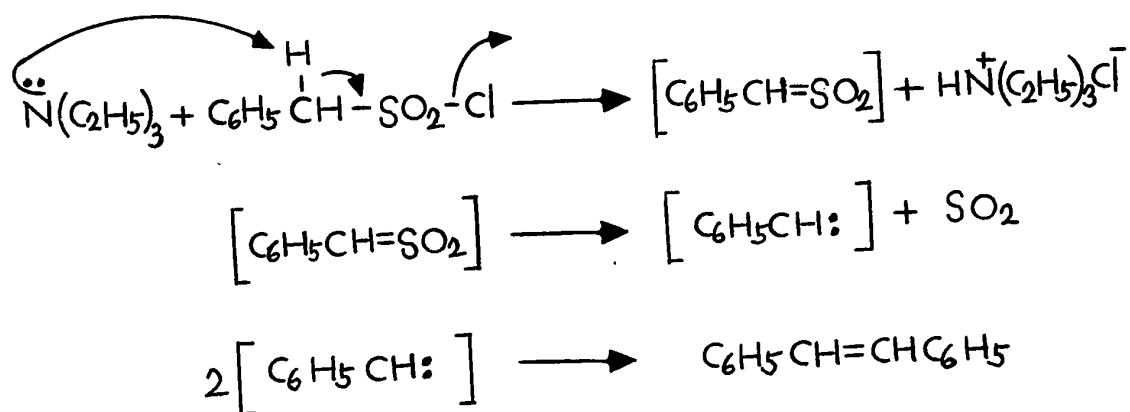

Fig. 7. Generation of a Sulphene Intermediate with Triethylamine.

Thus far, this is the most convenient way to generate sulphenes. When triethylamine is used, the dehydrohalogenation reaction proceeds rapidly for sulphonyl chlorides and bromides.<sup>10, 13</sup> With sulphonyl fluorides, however, the reaction is too slow to have preparative value.<sup>1(a), 13</sup> Dehydrohalogenation can best be carried out by means of trialkylamines in most, but not all cases.<sup>14</sup> Pyridine and similar cyclic imines are also suitable reagents although triethylamine is most commonly used for this purpose and has many advantages. It is easy to purify and remove from the reaction mixture. Its hydrochloride is easily separable since it is not hygroscopic and is only sparingly soluble in petroleum ether, benzene, diethyl ether, tetrahydrofuran and acetonitrile at  $-40^{\circ}$ .

Sulphenes can also be generated by the reaction of sulphur dioxide with diazoalkanes. Thus Standinger and Pfenniger<sup>3</sup> observed that diphenyldiazomethane in an inert solvent readily reacted with sulphur dioxide to produce tetraphenylethylene sulphone and tetraphenylethylene. Initial reaction of the diazo compound with sulphur dioxide, followed by loss of nitrogen led to diphenylsulphene (Fig. 8). Subsequent reaction with diphenyldiazomethane yielded tetraphenylethylene and sulphur dioxide. Similarly, the reaction of diazomethane with sulphur dioxide led to the formation of methanesulphene which further reacted with another molecule of diazomethane to produce ethylene sulphone.<sup>15</sup>

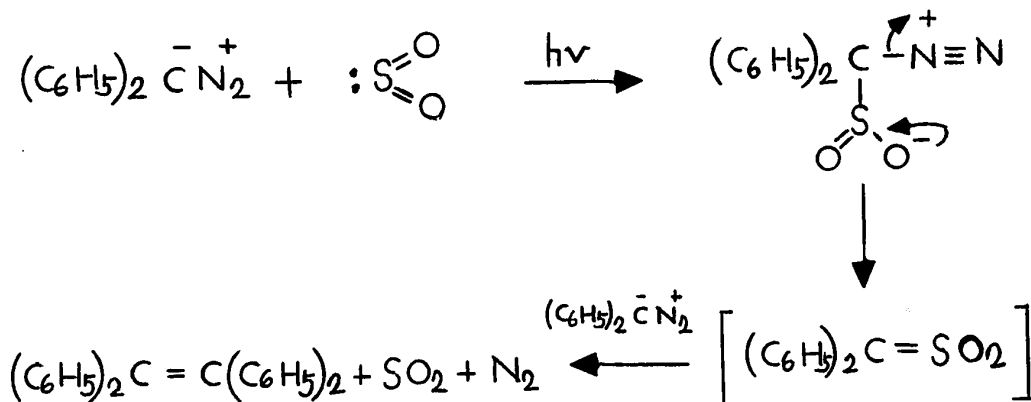

Fig. 8. Generation of a Sulphene Intermediate by the Reaction of Diphenyldiazomethane and Sulphur Dioxide.

Recently, King and co-workers reported four new routes to the generation of sulphene intermediates. First, irradiation of the sultone (I) in methanol resulted in the formation of the corresponding sulphene (II) which reacted further with methanol to form the methyl sulphonate ester (III) (Fig. 9).<sup>16</sup>

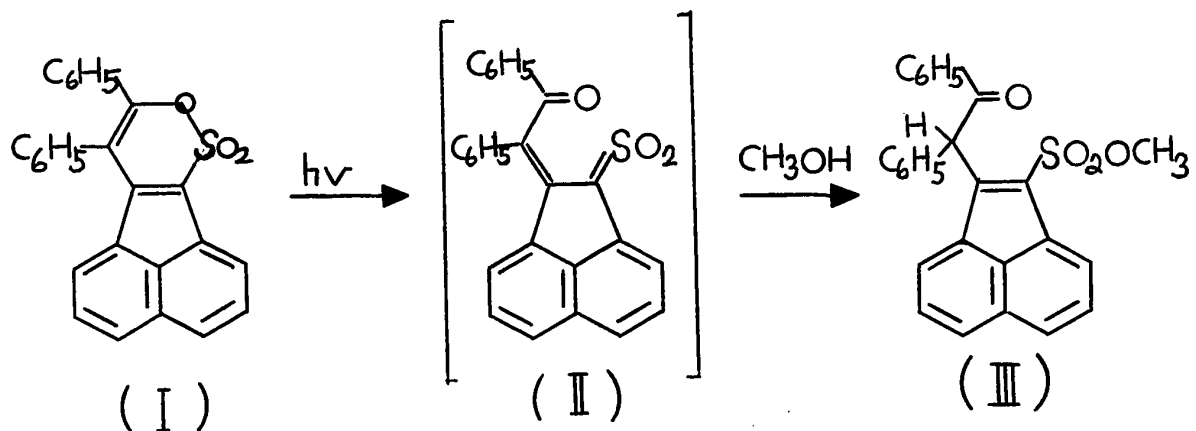

Fig. 9. Generation of a Sulphene Intermediate by Irradiation of a Sultone.

Second, heating the thiet 1,1-dioxide (IV) at  $375^{\circ}$  gave the unsaturated cyclic sulphinic ester (V) as shown in Figure 10.<sup>17</sup>

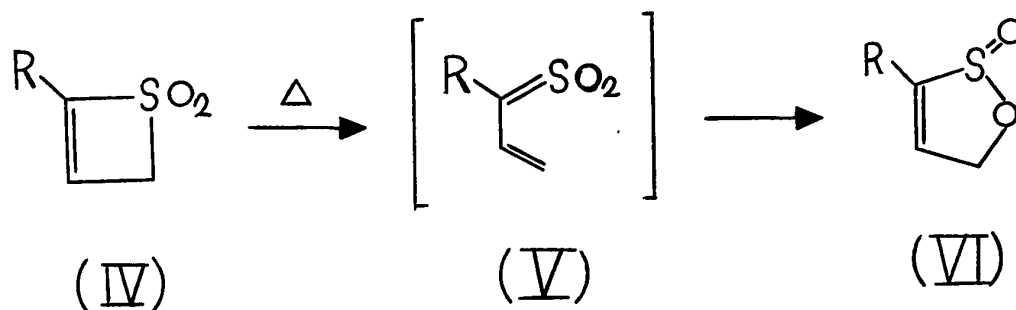

Fig. 10. Generation of a Vinylsulphene Intermediate from the Pyrolysis of a thiet 1,1-dioxide.

Third, chlorinolysis of 2 H-1,2,3-benzothiadiazine 1,1-dioxide (VII) gave the sulphene (VIII) which undergoes a carbonyl-like addition to form a chlorosulphinic ester (IX) as shown in Figure 11.<sup>18</sup>

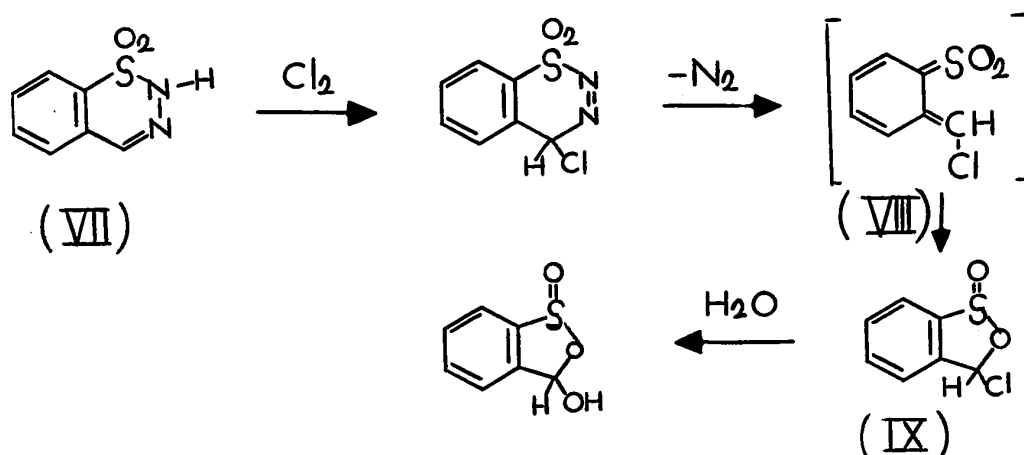

Fig. 11. Generation of a Sulphene Intermediate by Chlorinolysis of 2 H-1,2,3-benzothiadiazine 1,1-dioxide.

Fourth, warming 1-chloroethanesulphinic acid with sodium hydride gave products derived from methylsulphene with several trapping agents (Fig. 12).<sup>19</sup>

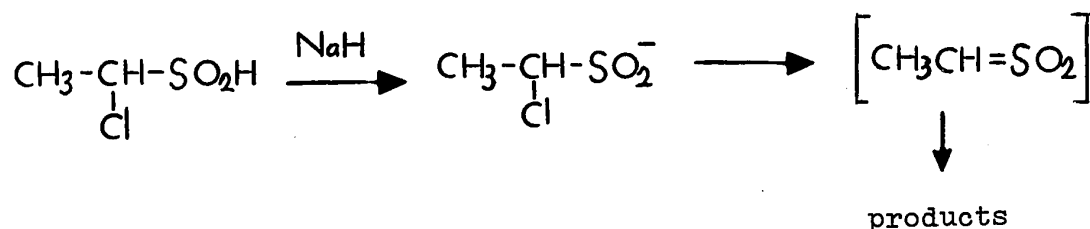

Fig. 12. Generation of a Sulphene Intermediate from the Reaction of Sodium Hydride with 1-Chloroethanesulphinic Acid.

Sixty years after the first experiments carried out by Wedekind and Schenk<sup>12</sup> a stable sulphene has yet to be isolated. In the belief that the relationship between the structure and the stability of sulphenes would very likely obey the same rules as other ylides, Paquette and co-workers<sup>20</sup> attempted to prepare some electronically stable sulphenes. Two models were tried without success (Fig. 13 and Fig. 14). First, the  $\alpha$ -carbalkoxyl group was examined for the possible assistance in the delocalization of the carbanionic character imparted to the  $\alpha$ -sulphonyl carbon atom (Fig. 13).

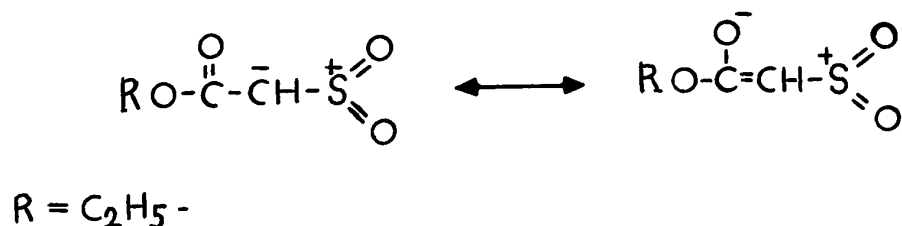

Fig. 13. A Proposed  $\alpha$ -Carbalkoxyl Stabilized Sulphene.



Although this sulphene intermediate was found to undergo characteristic cyclo-addition reactions attempts to isolate it were unsuccessful. Second, because of the stabilizing capacity of a cyclopentadienyl substituent on ylide structures the possibility of obtaining a stable 9-fluorensulphene was investigated (Fig. 14).

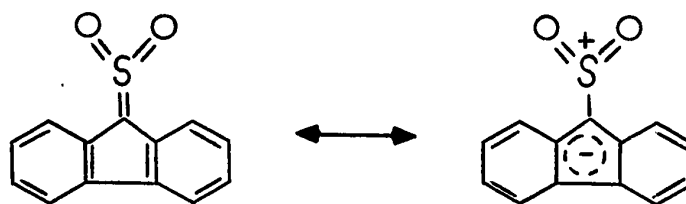

Fig. 14. Proposed 9-Fluorensulphene.

In the presence of *N,N*-dimethyl-1-isobutenylamine and triethylamine, 9-fluorensulphonyl chloride (I) was transformed into thietane dioxide (III) as illustrated in Figure 15.

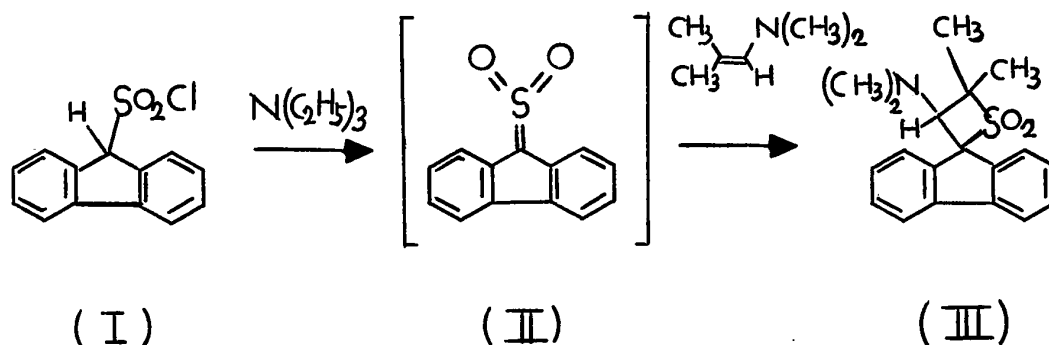

Fig. 15. Cyclo-addition Reaction of 9-Fluorensulphene Intermediate with *N,N*-Dimethyl-1-isobutenylamine.

Unfortunately, attempts to isolate the sulphene (II) were unsuccessful. The addition of triethylamine to an ethereal solution of 9-fluorensulphonyl chloride at low temperature afforded a bright yellow solid which exhibited only very weak sulphene absorption in the infrared spectrum.

The unsuccessful attempts to isolate a stable sulphene may be due to the nature of the systems chosen. The insufficient electronic stabilization effect of the  $\alpha$ -carbalkoxyl and the 9-fluorene structure and the absence of any sterically protective function may be the causes of failure.

Following Paquette's proposal that the structure-stability relationship of sulphenes may be similar to that of ylides, three models of stable sulphenes were proposed and it was decided to synthesize their precursor sulphonyl chlorides.

CHAPTER IIRESULTS AND DISCUSSION

Three models were proposed as potential stable sulphenes:  
 (A) diphenylmethanesulphene, (B) flaviansulphene, (C) 3,5-di-tert-butyl-4-quinoidsulphene (Fig. 16).

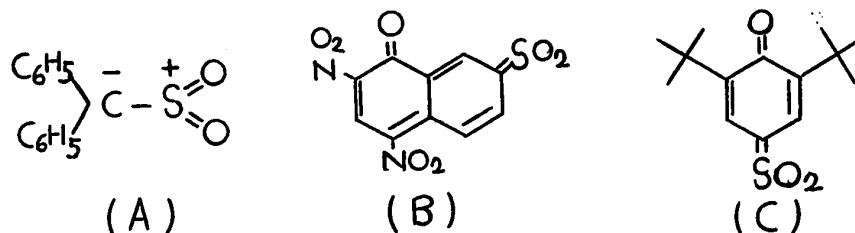

Fig. 16. Proposed Stable Sulphenes.

First of all, these choices were based on the relatively high molecular weight of these models. Secondly, the stabilizing capacity of the phenyl, the quinoid structure, and the nitro groups on the ylide structures should add more to the stabilization of these proposed model sulphenes. Moreover, the bulk effect of the 3,5-di-tert-butyl groups may block the quinoidsulphene from further reaction. Attempts were made to prepare the corresponding sulphonyl chlorides.

Attempted Synthesis of Diphenylmethanesulphonyl Chloride.

Over forty-eight years ago, Wedekind and co-workers<sup>20,21</sup> reported unsuccessful attempts to prepare diphenylmethanesulphonyl chloride and 9-fluorensulphonyl chloride. Optiz<sup>20</sup> generalized that two phenyl groups in the alpha position to

a chlorosulphonyl function caused sulphur dioxide elimination even at room temperature. However, Paquette and co-workers<sup>20</sup> prepared 9-fluorensulphonyl chloride in 32% yield (Fig. 17).

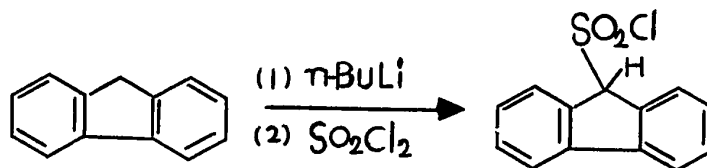

Fig. 17. Synthesis of 9-Fluorensulphonyl Chloride.

We attempted to prepare the diphenylmethanesulphonyl chloride by a similar route (Fig. 18).

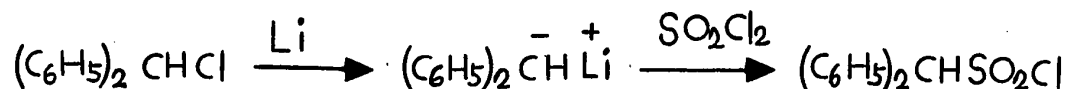

Fig. 18. Proposed Route to Diphenylmethanesulphonyl Chloride.

However, no sulphonyl chloride was isolated. After the addition of a blood red solution of lithium diphenylmethane to sulphuryl chloride at  $-40^\circ$  under a nitrogen atmosphere, a colorless solution was observed along with the evolution of sulphur dioxide. Careful evaporation of the solvent and excess sulphuryl chloride afforded a brown oil. The oil was analyzed and was found to consist of 1,1,2,2-tetraphenylethane and three other components. No attempt was made to identify the other components partly because of the complicated nmr spectrum and partly because of

the absence of the sulphonate function in the infrared spectrum. After several attempts, the synthesis was abandoned.

Attempted Synthesis of the Sulphonyl Chloride of Flavianic Acid.

The chlorination of flavianic acid should be relatively simple. However, after a mixture of flavianic acid and phosphorus pentachloride was stirred at room temperature for one hour, a red oil resulted. The infrared spectrum of the red oil showed the presence of the sulphonyl chloride bands and the complete absence of nitro bands. No attempt was made to further identify the red oil.

Another attempt was made to prepare the sulphonyl chloride under milder conditions (10 min at 0°C). The excess phosphorus pentachloride was destroyed with ice-water. The yellow solid obtained after drying showed interesting characteristics. The solid was soluble in benzene but insoluble in water. After recrystallization from benzene the solid obtained melted between the range of 40-50°C. Several attempts to further purify this compound such that a narrower melting range could be obtained, failed. The infrared spectrum indicated the presence of sulphonate group, nitro group, aromatic group and the absence of any hydroxyl function. This compound could be hydrolyzed to flavianic acid with water. The elemental analysis of the compound was at least reasonably close to the structure of a sulphene dimer. It is proposed that the compound may well be the

flaviansulphene dimer (I) as shown in Figure 19.

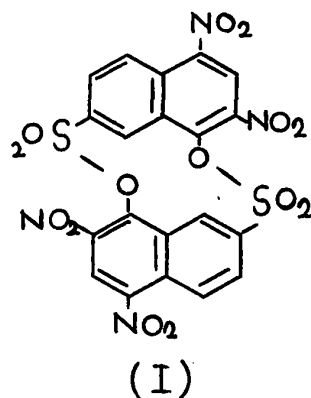

Fig. 19. Proposed Structure of Flaviansulphene Dimer.

This structure could be visualized as occurring in the following manner (Fig. 20).

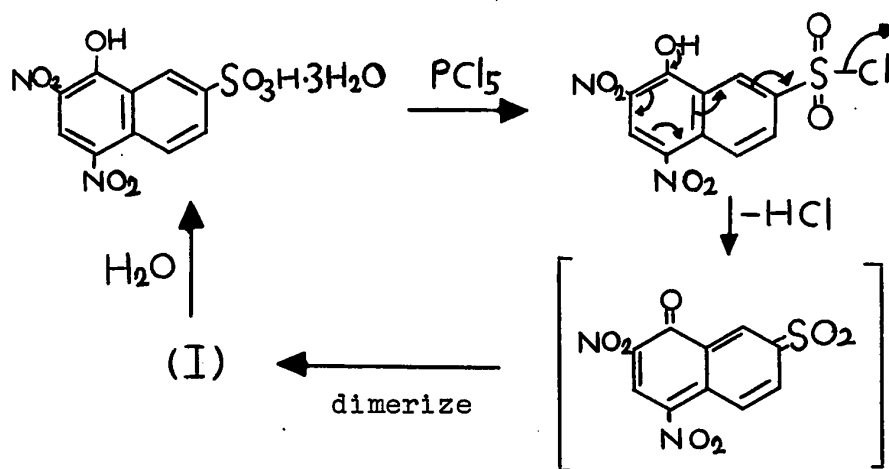

Fig. 20. Proposed Reaction of Flavianic Acid with Phosphorus Pentachloride.

It is obvious to this author that further work is necessary with the flavianic acid approach to a potential stable sulphene.

Synthesis of 3,5-Di-tert-butyl-4-hydroxybenzenesulphonyl Chloride.

Hall and co-workers<sup>22</sup> prepared 3,5-dimethyl-4-hydroxybenzenesulphonyl chloride by the following route (Fig. 21).

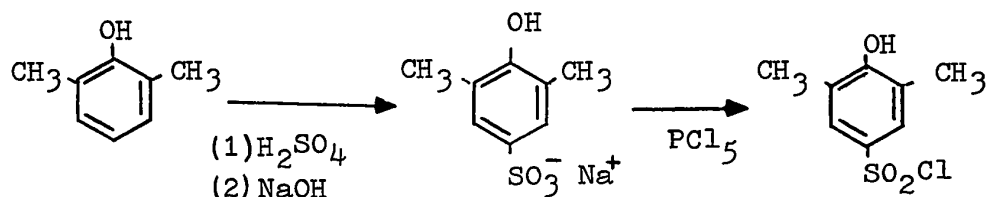

Fig. 21. Preparation of 3,5-Dimethyl-4-hydroxybenzenesulphonyl Chloride.

However, attempts to sulphonate the 2,6-di-tert-butylphenol by this method were unsuccessful. A loss of structural integrity was observed in every trial synthesis. The absence of a free hydroxyl group in the infrared spectrum of the sulphonated product indicated a structural change at the 2 and 6 position of the phenol molecule. The loss of a tertiary-butyl group is common when polyalkylbenzenes are treated with sulphuric acid.<sup>23</sup> This change of structure was observed in every trial. No attempt was made to identify these products.

An unsuccessful attempt was made to use chlorosulphonic acid as a chlorosulphonating agent.<sup>24</sup> The products obtained were not characterized because the elemental analysis of the product mixture showed the absence of chlorine. A multicomponent

mixture was observed using thin layer chromatography. Finally sulphonation using a sulphur trioxide-dioxane complex<sup>25</sup> gave excellent results (ca. 70% overall yield). The corresponding sulphonyl chloride was prepared and characterized without complications (Fig. 22).

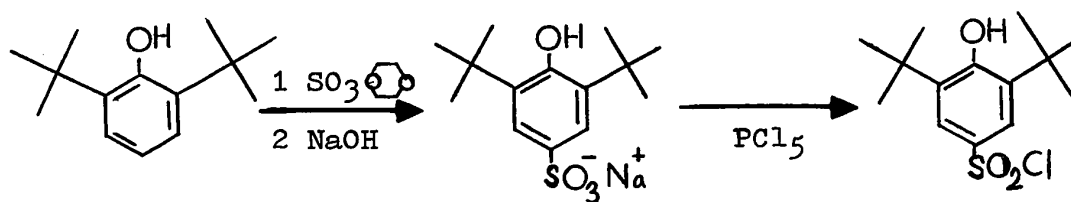

Fig. 22. Preparation of 3,5-Di-tert-butyl-4-hydroxybenzenesulphonyl Chloride.

After finding this successful route to what could be a general class of 3,5-disubstituted-4-hydroxybenzenesulphonyl chlorides as potential precursors for stable quinoid sulphenes it was decided to defer the program for future studies.



CHAPTER IIIEXPERIMENTAL

All instruments used and data obtained were recorded in the same way as described in Part II of the thesis.

Attempted Synthesis of Diphenylmethanesulphonyl Chloride. -

The lithium diphenylmethane solution in tetrahydrofuran was prepared by the method of Tamborski.<sup>26</sup> The above blood red solution (50 mmole) was added dropwise to an excess of sulphuryl chloride (20 ml, 250 mmole) at  $-40^{\circ}$  under a nitrogen atmosphere. The color of the solution discharged immediately with simultaneous evolution of sulphur dioxide. Careful evaporation of the solvent and excess sulphuryl chloride in vacuo afforded a brown oil (8.5 g). Upon the addition of pentane to the oil, a white solid crystallized. After filtration, 4.2 g (25%) of pure 1,1,2,2-tetraphenylethane was obtained: mp  $217-220^{\circ}$  (lit.<sup>26</sup> mp  $217-220^{\circ}$ ); ir ( $\text{CHCl}_3$ , 10%) 3060 and 3020 (m, ArH), 2920 (s, C-H), 1600 and 1490 (m, Ar); nmr ( $\text{CDCl}_3$ , 10%) 4.78 (s, 2, ArCH), 7.13 (s, 20,  $\text{C}_6\text{H}_5$ ). The filtrate was washed three times with cold water and the organic layer was separated, dried and concentrated in vacuo. The brown oil obtained weighed 4.1 g: ir ( $\text{CHCl}_3$ , 10%) 3060 and 3010 (m, ArH), 2910 (m, C-H), 1600 and 1490 (m, Ar), 1100 (s), 1050 (s), 1022 (m); nmr ( $\text{CDCl}_3$ , 10%) 1.5 to 3.0 (m) 3.5 to 4.5 (m), 5.40 (s), 6.13 (s), 6.23 (s), 6.9 to 7.4 (m). Tlc (silica gel, pentane) showed three main spots with one corresponding to benzhydryl chloride. The analysis of elements

of the oil showed the absence of sulphur but the presence of chlorine. This procedure was repeated several times and the same results were obtained in each case.

Attempted Synthesis of the Sulphonyl Chloride of Flavianic Acid. -

The flavianic acid (3.7 g, 10 mmole) was mixed with phosphorus pentachloride (12 g, 58 mmole) in a clean dry conical flask. Hydrogen chloride evolved immediately and the reaction was cooled in an ice bath. The solids dissolved forming a blood red solution after stirring for 1 h at room temperature. To the solution, 30 g of chopped ice was added with stirring. The resultant mixture was filtered and washed three times with cold water. The solid after drying in vacuo weighed 2.1 g: ir (CHCl<sub>3</sub>, 10%) 3080 and 3.10 (w, ArH), 1800 to 1650 (m), 1600 and 1500 (m, Ar), 1390 and 1175 (s, SO<sub>2</sub>Cl). The ir spectrum showed no evidence of the nitro group. No attempt was made to characterize this solid.

Another attempt was made to carry out the same experiment under milder conditions. A mixture of flavianic acid (10.0 g, 27 mmole) and phosphorus penta-chloride (34.0 g, 162 mmole) was stirred for 10 min at 0°. The solid which formed was isolated and dried in vacuo affording a crude yield of 7.7 g. Recrystallization from benzene gave yellow cubic crystals: mp 40-50°; ir (CHCl<sub>3</sub>, 10%) 3100 and 3050 (m, ArH), 1630, 1680, 1590 (s, Ar), 1530 and 1330 (s, NO<sub>2</sub>), 1390 and 1180 (s, SO<sub>3</sub>). It is interesting to note that this solid showed no hydroxyl bands in the ir spectrum. The unknown solid was hydrolyzed in the following manner. The solid (2.0 g) was dissolved in

chloroform (10 ml) and was then refluxed in water (50 ml) for 1 h. After the removal of solvent and water, 2.1 g of flavianic acid was obtained; mp 109-110°C. The ir spectrum was identical to that of a pure sample of the acid. The melting point showed no depression on the admixture of authentic flavianic acid.

Anal. Calcd. for the flaviansulphene dimer:

C, 40.55; H, 1.36; N, 9.46; S, 10.82.

Found: C, 41.14; H, 2.22; N, 7.61; S, 8.86.

Synthesis of 3,5-Di-tert-butyl-4-hydroxybenzenesulphonyl Chloride.

(A) Sulphuric Acid as a Sulphonating Agent - The sulphonation of 2,6-di-tert-butylphenol was carried out according to the method of Hall.<sup>22</sup> Thus, after heating a mixture of 2,6-di-tert-butylphenol (10.0 g, 50 mmole) and 84% sulphuric acid (6.0 g, 50 mmole) at 100°C for 30 min the reaction mixture was poured onto a saturated sodium chloride solution (50 ml). The precipitate was allowed to settle several hours before filtration. It was then washed several times with saturated salt solution and petroleum ether (bp 30-60°). The solid after drying at 60°C in vacuo for 12 h weighed 12.2 g: ir (KBr, 1%) 3500 to 3050 (s, bonded OH), 2960 (s, C-H), 1608 and 1500 (m, Ar), 1414 and 1360 (m, C-H), 1220 (s), 1190 (s), 1090 (s), 1030 (s). The same results were obtained when the reaction was run at 25° and 0°C.

(B) Chlorosulphonic Acid as a Sulphonating Agent - A solution of 1.0 g (5 mmole) of 2,6-di-tert-butylphenol in 5 ml of dry chloroform in a clean conical flask was cooled in a beaker of ice at 0°C. Chlorosulphonic acid (5 ml) was added dropwise with adequate shaking. After the mixture warmed up to room temperature, the contents of the flask were poured into a 50 ml beaker containing chopped ice. The chloroform layer was removed and washed with water. It was then dried over anhydrous sodium sulphate filtered and concentrated in vacuo. The resultant yellow oil was refrigerated for 12 h. No crystalline solid was obtained. Elemental analysis<sup>24</sup> of the oil indicated the presence of sulphur but the absence of chlorine. Tlc (silica gel, chloroform) showed a multicomponent mixture. No attempt were made to isolate the compounds.

(C) Sulphur Trioxide-Dioxane 1:1 Complex as a Sulphonating Agent - The 1:1 sulphur trioxide-dioxane complex was prepared according to the method of Gilbert.<sup>25</sup> A solution of 2,6-di-tert-butylphenol (37.0 g, 180 mmole) in 50 g of methylene chloride was added dropwise to the sulphur trioxide-dioxane complex (180 mmole) in a three-necked, round-bottomed flask which was fitted with a mechanical stirrer a condenser and a dropping funnel. The reaction was slightly exothermic and was held at 0°C during the addition. After the addition was completed, the reaction mixture was allowed to warm to 25°C whereupon the solvent was evaporated. The sodium salt of 3,5-di-tert-butyl-4-hydroxybenzenesulphonic acid was obtained by

stirring the reaction mixture with 100 ml of saturated sodium chloride solution and 100 ml of petroleum ether (bp 30-60°C). The salt was collected by filtration. It weighed 56.2 g after drying at 100°C for 12 h. The crude salt was used for subsequent reactions without further purification.

Chlorination of Sodium 3,5-Di-tert-butyl-4-hydroxybenzene-sulphonate - A mixture of the crude sulphonic acid salt (20.0 g) and phosphorus pentachloride (45.0 g, 0.21 mole) was heated in a round-bottomed flask at 100°C for 30 min. The mixture was cooled to 25°C and 300 ml of benzene was added. The solution was filtered, washed twice with 50 ml portion of ice cold water, dried and concentrated in vacuo. The resultant solid weighed 14.2 g (ca. 70%). Recrystallization from benzene gave pure 3,5-di-tert-butyl-4-hydroxybenzene-sulphonyl chloride: mp 160-161°C; ir (10%, CHCl<sub>3</sub>) 3630 (s, free O-H) 2970 (s, C-H), 1570 and 1480 (m, Ar), 1370 and 1160 (s, SO<sub>2</sub>Cl); nmr (10%, CDCl<sub>3</sub>) 1.53 (s, 18, (C(CH<sub>3</sub>)<sub>3</sub>)<sub>2</sub>), 6.1-6.2 (bs, 1, OH), 8.00 (s, 2, C<sub>6</sub>H<sub>2</sub>).

Anal. for C<sub>14</sub>H<sub>21</sub>O<sub>3</sub>SCl:

Calcd. C, 55.16; H, 6.94; S, 10.52; Cl, 11.63.

Found : C, 54.93; H, 6.59; S, 10.25; Cl, 11.81.

References

1. For reviews, see (a) G. Optiz Angew. Chem., 6, 107 (1967).  
(b) T. J. Wallace, Quarterly Reviews, 20, 67 (1966).
2. W. E. Truce, R. W. Campbell, and J. C. Martin, J. Amer. Chem. Soc., 86, 288 (1964).
3. H. Staudinger and F. Pfenniger, Ber., 49, 1941 (1961).
4. G. Optiz and K. Fischer, Angew. Chem. 77, 41 (1965). Angew. Chem. internat. Edit., 4, 70 (1965).
5. R. H. Hasek, P. G. Gott, R. H. Meen, and J. C. Martin, J. Org. Chem., 28, 2496 (1963).
6. W. E. Truce, J. R. Norell, R. W. Campbell, D. G. Bardy, and J. W. Fieldhouse, Chem. and Ind. 1965, 1870.
7. G. Optiz and F. Schweinsberg, Angew. Chem., 77, 811 (1965); Angew. Chem. intern. Edit., 4, 786 (1965).
8. R. Fusco, S. Rossi, and S. Maiorana, Chem. Ind. (milano) 45, 564 (1963).
9. G. Optiz, M. Kleemann, D. Bucher, G. Walz, and K. Reith, Angew. Chem., 78, 604 (1966); Angew. Chem. internat. Edit., 5, 594 (1966). G. Optiz and D. Bucher, Tetrahedron Letters 1966, 5263.
10. J. Strating, Recueil Trav. Chem. Pays-Bas, 83, 94 (1964).
11. T. Durst and J. F. King, Can. J. Chem., 44, 1869 (1966).
12. E. Wedekind and D. Schenk, Ber., 44, 198 (1911).
13. J. F. King, and T. Durst, Can. J. Chem., 44, 819 (1966).
14. W. E. Truce, R. W. Campbell, and J. R. Norell, J. Amer. Chem. Soc., 86, 288 (1964).

15. G. Hesse, E. Reichlod, and S. Majmudar, Chem. Ber., 90, 2106 (1957).
16. J. F. King, P. DeMayo, E. Morkved, A. B. M. A. Satter, and A. Stoessl, Can. J. Chem., 41, 100 (1963).
17. J. F. King, K. Piers, David J. H. Smith, C. L. McIntosh, and P. de Mayo, Chem. Comm., 31 (1969).
18. J. F. King, Anne Hawson, Donna M. Deaken, and J. Komery, Chem. Comm., 33 (1969).
19. J. F. King and R. P. Beatson, Chem. Comm., 663 (1970).
20. L. A. Paquette, J. P. Freeman and R. W. Houser, J. Org. Chem., 34, 2901 (1969).
21. E. Wedekind and R. Stusser, Ber., 56, 1557 (1923).
22. W. L. Hall, J. Org. Chem., 31, 2673 (1966).
23. L. I. Smith, "Organic Reactions", Vol. 1, editor in chief R. Adams, John Wiley and Sons, Inc., New York, 1963, p. 370.
24. R. L. Shriner, R. C. Fuson and D. Y. Curtin, "The Systematic Identification of Organic Compounds", 4th ed., John Wiley and Sons, Inc., New York, N. Y., 1956, p. 246.
25. E. E. Gilbert, "Sulphonation and Related Reactions", Interscience, New York, N. Y., 1965, chapter I.
26. C. Tamborski, Chem. and Ind., 4, 696 (1962).

VITA AUCTORIS

## Born:

April 6, 1943; Canton, China.

## Education:

Un Long Public Middle School, Hong Kong. 1956-1962.

Chung Chi College, Hong Kong. 1962-1966.

University of Windsor, Windsor, Ontario. 1966-1972.

## Publications:

"A mechanistic study of the base-catalyzed methanolysis and hydrolysis of the hydrogen phthalate ester of 4-bromo-4'-nitrobenzhydrol." K. G. Rutherford, O. A. Mamer and B. K. Tang, Can. J. Chem., 47, 1487 (1969).

"An Improvement of the Chugaev Reaction with Tertiary Alcohols." K. G. Rutherford, R. M. Ottenbrite and B. K. Tang, J. Chem. Soc., (C), 582 (1971).

## Professional Societies:

The Chemical Institute of Canada,

The Chemical Society of London.

## Marital Status:

Single.