

2014

Complex Industrial Sociotechnical Systems Dynamics Modeling and Ramp-up

Zulfiqar Zaq Ali Qureshi
University of Windsor

Follow this and additional works at: <http://scholar.uwindsor.ca/etd>

Recommended Citation

Qureshi, Zulfiqar Zaq Ali, "Complex Industrial Sociotechnical Systems Dynamics Modeling and Ramp-up" (2014). *Electronic Theses and Dissertations*. Paper 5093.

This online database contains the full-text of PhD dissertations and Masters' theses of University of Windsor students from 1954 forward. These documents are made available for personal study and research purposes only, in accordance with the Canadian Copyright Act and the Creative Commons license—CC BY-NC-ND (Attribution, Non-Commercial, No Derivative Works). Under this license, works must always be attributed to the copyright holder (original author), cannot be used for any commercial purposes, and may not be altered. Any other use would require the permission of the copyright holder. Students may inquire about withdrawing their dissertation and/or thesis from this database. For additional inquiries, please contact the repository administrator via email (scholarship@uwindsor.ca) or by telephone at 519-253-3000ext. 3208.

Complex Industrial Sociotechnical Systems Dynamics Modeling and Ramp-up

By

ZULFIQAR (ZAQ) ALI QURESHI

A Dissertation

Submitted to the Faculty of Graduate Studies

through Department of Industrial and Manufacturing System Engineering

in Partial Fulfillment of the Requirements for

the Degree of Doctor of Philosophy

at the University of Windsor

Windsor, Ontario, Canada

2014

© 2014 Ali-Qureshi, Z.

Complex Industrial Sociotechnical Systems Dynamics Modeling and Ramp-up

By

Zulfiqar (ZAQ) Ali Qureshi

APPROVED BY:

E. Orady, External Examiner
University of Michigan, Dearborn Detroit, USA.

M. F. Baki,
Odette School of Business.

Z. J. Pasek,
Industrial and Manufacturing Systems Engineering.

H. A. ElMaraghy,
Industrial and Manufacturing Systems Engineering.

W. H. ElMaraghy, Advisor
Industrial and Manufacturing Systems, Engineering.

April 24 2014

DECLARATION OF ORIGINALITY

I hereby certify that I am the sole author of this Dissertation and that no part of this Dissertation has been published or submitted for publication.

I certify that, to the best of my knowledge, my Dissertation does not infringe upon anyone's copyright nor violate any proprietary rights and that any ideas, techniques, quotations, or any other material from the work of other people included in my Dissertation, published or otherwise, are fully acknowledged in accordance with the standard referencing practices. Furthermore, to the extent that I have included copyrighted material that surpasses the bounds of fair dealing within the meaning of the Canada Copyright Act, I certify that I have obtained a written permission from the copyright owner(s) to include such material(s) in my Dissertation and have included copies of such copyright clearances to my appendix.

I declare that this is a true copy of my Dissertation, including any final revisions, as approved by my Dissertation committee and the Graduate Studies office, and that this Dissertation has not been submitted for a higher degree to any other University or Institution.

ABSTRACT

The aim of this research is to study emerging ramp up scenarios in the context of complex sociotechnical dynamic systems. These represent industrial and manufacturing companies that are facing fierce competition due to globalization and free trade, and the race to be in the market first with new products. Furthermore, for every manufacturer to launch their newly designed products in market and introduce the latest functionality attributes, or improve quality of their products, effective and fast ramp up is necessary for capturing a good market share. This makes the production ramp up a back bone in modern manufacturing; as its effective management enables faster ramp-up every time a change is brought in the quality, quantity features and fabrication at design, system and process level while integrating systems logical and physical enablers. In this context, models of ramp up scenario have been explored by setting up nonlinear system dynamic models in order to understand complex trends and behaviours for large and complex systems.

Apart from that, novelty of these introduced system dynamic models is the set-up of an analogy to understand what impact they can produce when the respective parameters are perturbed and how this will affect the whole system and related sub-systems when they together form a system of systems (SOS). Prior research has demonstrated that variety, due to mass customization and personalization, introduces complexity in the design as well as in manufacturing process due to production mix. Complexity is modelled and implemented, not only at the system and sub system levels but also at machine level and product level, by improving design for assembly (DFA) and design for manufacturing (DFM). In the end, sociotechnical aspects and risk assessment involving “triple bottom line” impact factor analysis have been explored with respect to new product design by studying utility function and trigonometry.

Finally, a comprehensive model is developed and analyzed with human behavior core attributes by applying Porter’s theory of motivation and system dynamic. This model highlights major impacts of motivation theory, by providing intrinsic and extrinsic rewards impact on labor which enables an understanding of behavior pattern of labour in relation to work assigned. Lastly, but not the least, this dissertation has contributed and demonstrated the potential usefulness of modeling complex industrial sociotechnical systems by using system dynamic approach for ramp-up.

DEDICATION

I dedicate this dissertation to my beloved kids and my respectable spouse whose patience made me see this day. My parents who nurtured me at their best along with imparting best of their nature which is part and parcel of my genetic mental makeup. I love my parents, Abbu and Ammi, I love my family, and I thank all mighty God, for this accomplishment.

ACKNOWLEDGEMENTS

I thank my mentor and supervisor Professor Dr. Waguih ElMaraghy, for his efforts and generosity as well as Professor Dr. Hoda ElMaraghy, Directors of the Intelligent Manufacturing Systems Centre (IMSC) at the University of Windsor for their guidance and support, and also for extending their resources and research facilities which were very valuable for the use of my integrated research work. I am also thankful to Prof. Dr. J.R.Urbancic, Prof. Dr. A. I. Azab, Prof. Dr. M.F. Baki, and last but not least, Professor Dr. Z. J. Pasek, for their continuous encouragement.

Beside the Professors, I am also thankful to the Staff of the Department of Industrial and Manufacturing Systems Engineering (IMSE): Ms. Brenda Schreiber, Ms. Jackie Mummery, Ms. Angela Haskell, Mr. Ram Barakt, Ms. Zaina Batal, Ms. Erica Lyons, Ms. Sandra Mahenka, and Ms. Qin Tu. It has been my pleasure to interact with you all during my period of graduate studies in IMSE.

I salute and “hats off” to you all for the tremendous services which you all have had rendered in the Department of Industrial & Manufacturing Systems Engineering (IMSE), and in my mother institution of University of Windsor.

TABLE OF CONTENTS

DECLARATION OF ORIGINALITY.....	iii
ABSTRACT.....	iv
DEDICATION.....	v
ACKNOWLEDGEMENTS.....	vi
LIST OF TABLES	x
LIST OF FIGURES.....	xi
LIST OF NOMENCLATURE.....	xv
LIST OF EQUATIONS	xvii

I	INTRODUCTION.....	1
1.1	<i>Research Background.....</i>	<i>1</i>
1.2	<i>Status Quo of Sustainable Designon.....</i>	<i>3</i>
1.3	<i>Status Quo of Sustainable Production.....</i>	<i>4</i>
1.4	<i>The Problem in Focus.....</i>	<i>4</i>
1.5	<i>Statement of Hypothesis of the thesis.....</i>	<i>6</i>
1.6	<i>Objective of Research.....</i>	<i>7</i>
1.7	<i>How the objective is to be achieved.....</i>	<i>7</i>
1.8	<i>Organization of the thesis.....</i>	<i>9</i>
II	MOTIVATIONS AND SCOPE.....	10
2.1	<i>System Engineering Focus.....</i>	<i>10</i>
2.2	<i>Criticizing the Evolutionary Effects of Innovation.....</i>	<i>10</i>
2.3	<i>Understanding the Nature of Systems and System Thinking.....</i>	<i>10</i>
2.4	<i>Context of System Engineering.....</i>	<i>11</i>
2.5	<i>Knowledge based Complex System.....</i>	<i>11</i>
2.6	<i>Analyses of a Large Scale System Design.....</i>	<i>12</i>
2.7	<i>Evolution of System of Systems (SOS).....</i>	<i>13</i>
2.8	<i>Emergence of Global System of Systems.....</i>	<i>13</i>

III	LITERATURE REVIEW OF RAMP UP PLANING.....	15
3.1	<i>Ram-up Manufacturing Conceptual Preview.....</i>	<i>15</i>
3.2	<i>Need for the Ramp-up.....</i>	<i>16</i>
3.3	<i>System Engineering Perspective of Rapid Ramp-up.....</i>	<i>16</i>
3.4	<i>Critical Literature Review and Research Gap.....</i>	<i>18</i>
IV	ELLEMENTS OF EFFECTIVE PRODUCTION RAMP UP.....	23
4.1	<i>Effectiveness of the Ramp–up and Automobile.....</i>	<i>23</i>
4.2	<i>Ramp-up Activities.....</i>	<i>23</i>
4.3	<i>Elements of Modeling Effective Ramp-up Production.....</i>	<i>25</i>
4.4	<i>Procurement of Reconfigurable Assembly system.....</i>	<i>28</i>
	<i>Case Study # 4.1.....</i>	<i>29</i>
	<i>Case Study # 4.2.....</i>	<i>33</i>
	<i>Case Study # 4.3.....</i>	<i>37</i>
	<i>Case Study # 4.4.....</i>	<i>42</i>
	<i>Case Study # 4.5.....</i>	<i>49</i>
4.5	<i>Sociotechnical aspect of assembly system.....</i>	<i>58</i>
	<i>4.5.1 Physical Elements Related Issues.....</i>	<i>59</i>
	<i>4.5.2 Assembly Process Related Issues.....</i>	<i>59</i>
	<i>4.5.3 Cognitive Elements Related Issues.....</i>	<i>59</i>
	<i>Case Study # 4.6.....</i>	<i>61</i>
	<i>Case Study # 4.7.....</i>	<i>64</i>
	<i>Case Study # 4.8.....</i>	<i>70</i>
	<i>Case Study # 4.9.....</i>	<i>75</i>
	<i>Case Study # 4.10.....</i>	<i>79</i>
V	SOCIOTECHNICAL SYSTEM RISK ASSESMENT AND EQUILIBRIUM ANALYSIS.....	87
5.1	<i>Introduction</i>	<i>87</i>
5.2	<i>System Level Attribute Representation and Assessment Tool</i>	<i>87</i>

5.3	<i>Implementation and Case Study</i>	89
5.4	<i>Environmental Engineering Aspects</i>	90
5.5	<i>Engineering Economic Aspects</i>	90
5.6	<i>Social Engineering Aspects</i>	92
5.7	<i>Result and Analysis</i>	93
VI SOCIAL AND PSYCHOLOGICAL ASPECT OF TECHNICAL		
MANAGEMENT A NEW PARADIGM IN SOCIOTECHNICAL SYSTEM		
DESIGN.....97		
6.1	<i>Perspective on Personality and Behaviour</i>	97
6.2	<i>Motivation Theory</i>	97
6.3	<i>Porter-Lawler Model of Motivation</i>	98
	<i>Case Study # 6.1</i>	100
VII SUMMARY AND CONCLUSIONS113		
REFERENCES.....121		
APPENDICES.....128		
<i>Appendix A Glossary of useful Important Terms</i>128		
<i>Appendix B Basic IDEFo Concept Based Analogy Model for Ramp-up</i>131		
<i>Appendix C Modeling Tools for Systems Dynamics</i>133		
<i>Appendix D Simulation Controle Parameters of Selected ramp up problems</i>135		
<i>Appendix E Mapping important relationship of selected ram up model problem</i> 143		
<i>Appendix F Key Words Based Literature Search</i>146		
<i>Appendix G List of Publications and Presentations</i>152		
VITA AUCTORIS.....154		

LIST OF THE TABLES

<i>Table 4.1</i>	<i>Variable Name and Definitions for Case Study # 4.1.....</i>	<i>29</i>
<i>Table 4.2</i>	<i>Base Case Variables for Case Study # 4.1.....</i>	<i>30</i>
<i>Table 4.3</i>	<i>Variable Names and Definition for Case Study # 4.2.....</i>	<i>34</i>
<i>Table 4.4</i>	<i>Base Case Variables of Case Study # 4.2.....</i>	<i>35</i>
<i>Table 4.5</i>	<i>Variable Names and Definition for Case Study #4.3.....</i>	<i>38</i>
<i>Table 4.6</i>	<i>Base Case Variables of Case Study # 4.3.....</i>	<i>38</i>
<i>Table 4.7</i>	<i>Variable Names and Definitions for Case Study # 4.4.....</i>	<i>43</i>
<i>Table 4.8</i>	<i>Base Case Variables for Case Study # 4.4.</i>	<i>43</i>
<i>Table 4.9</i>	<i>Variable Names And Definition For Case Study # 4.5.....</i>	<i>50</i>
<i>Table 4.10</i>	<i>Base Case Variables for Case Study # 4.5.....</i>	<i>50</i>
<i>Table 4.11</i>	<i>Variable Name for Case Study # 4.6</i>	<i>62</i>
<i>Table 4.12</i>	<i>Base Case Variables for Case Study # 4.6</i>	<i>62</i>
<i>Table 4.13</i>	<i>Variable Names and Definition Case Study # 4.7.....</i>	<i>65</i>
<i>Table 4.14</i>	<i>Base Case Variables for Case Study # 4.7.....</i>	<i>65</i>
<i>Table 4.15</i>	<i>Variable Names and Definition for Case Study # 4.8.....</i>	<i>72</i>
<i>Table 4.16</i>	<i>Base Case Variables for Case Study # 4.8.....</i>	<i>72</i>
<i>Table 4.17</i>	<i>Variable Names and Definition for Case Study # 4.9.....</i>	<i>75</i>
<i>Table 4.18</i>	<i>Base Case Variables For Case Study # 4.9.....</i>	<i>76</i>
<i>Table 4.19</i>	<i>Variable Names and Definition for Case Study # 4.10.....</i>	<i>80</i>
<i>Table 4.20</i>	<i>Base Case Variables for Case Study # 4.10.....</i>	<i>81</i>
<i>Table 5.1</i>	<i>General Environmental Focus</i>	<i>91</i>
<i>Table 5.2</i>	<i>General Economics Focus.....</i>	<i>91</i>
<i>Table 5.3</i>	<i>General Social Engineering Focus.....</i>	<i>92</i>
<i>Table 5.4</i>	<i>Over All Parameter and Alternative for Analysis</i>	<i>93</i>
<i>Table 5.5</i>	<i>Impact Factor Index Environmental and Engineering.....</i>	<i>96</i>
<i>Table 6.1</i>	<i>Variable Definition For Case Study # 6.1.....</i>	<i>100</i>
<i>Table 6.2</i>	<i>Base Case Variables For Case Study # 6.1.....</i>	<i>102</i>

LIST OF FIGURES

<i>Figure 1.1</i>	<i>Extended Objective of Design for 21st Century (ElMaraghy (2013)).</i>	3
<i>Figure 1.2</i>	<i>Frame Work for Effective Production Ramp-up.....</i>	8
<i>Figure 2.1</i>	<i>Evolution of Global SOS (Adopted from De Weck et al. 2011)).....</i>	13
<i>Figure 2.2</i>	<i>SOS Model (Adopted from ElMaraghy et al. (2012)).....</i>	14
<i>Figure 3.1</i>	<i>Complex Product/System Development Process V Model (Adopted from ElMaraghy (2009)).....</i>	17
<i>Figure 4.1</i>	<i>Holistic System View of Ramp Up Production.....</i>	24
<i>Figure 4.2</i>	<i>Contribution of Control Software System.....</i>	24
<i>Figure 4.3</i>	<i>Model for Economic Order Quantity.....</i>	28
<i>Figure 4.4</i>	<i>Key Relationship for Economic Order Quantity.....</i>	29
<i>Figure 4.5</i>	<i>Price of Each Product.....</i>	31
<i>Figure 4.6</i>	<i>The EOQ at Current State.....</i>	31
<i>Figure 4.7</i>	<i>Rate of Carrying Cost.....</i>	31
<i>Figure 4.8</i>	<i>Present Capacity.....</i>	32
<i>Figure 4.9</i>	<i>EOQ Change in Behavior.....</i>	32
<i>Figure 4.10</i>	<i>Rate of Carrying Cost Change</i>	32
<i>Figure 4.11</i>	<i>Multivariate Simulation Results.....</i>	33
<i>Figure 4.12</i>	<i>Individual Traces Simulation Results.....</i>	33
<i>Figure 4.13</i>	<i>Model Number of Machine Required for Manufacturing</i>	34
<i>Figure 4.14</i>	<i>Key Relation Number of Machine Required for Manufacturing</i>	34
<i>Figure 4.15</i>	<i>Numbers of Machines for Similar Part Family.....</i>	36
<i>Figure 4.16</i>	<i>Reliability of The Machines.....</i>	36
<i>Figure 4.17</i>	<i>Results of Multivariate Simulation.....</i>	37
<i>Figure 4.18</i>	<i>Results of Individual Traces Sensitivity.....</i>	37
<i>Figure 4.19</i>	<i>Modeling Dynamics of The Finished Goods to Customer.....</i>	37
<i>Figure 4.20</i>	<i>Presents Capacity.....</i>	39
<i>Figure 4.21</i>	<i>EOQ Estimate.....</i>	40
<i>Figure 4.22</i>	<i>Finished Goods Pattern to the Customer</i>	40
<i>Figure 4.23</i>	<i>Multivariate Simulation result.....</i>	40
<i>Figure 4.24</i>	<i>Individual Traces of Multivariate Sensitivity.....</i>	41

<i>Figure 4.25</i>	<i>Key Relations of the Model.....</i>	<i>41</i>
<i>Figure 4.26</i>	<i>Modeling Integrated aspect for Meeting the Target.....</i>	<i>42</i>
<i>Figure 4.27</i>	<i>Daily With Holding Cost.</i>	<i>45</i>
<i>Figure 4.28</i>	<i>Total With Holding Cost.....</i>	<i>45</i>
<i>Figure 4.29</i>	<i>Economic Order Quantity.....</i>	<i>45</i>
<i>Figure 4.30</i>	<i>Total Cost of All Parts.....</i>	<i>46</i>
<i>Figure 4.31</i>	<i>Total Cost of All Parts Multivariate Simulation</i>	<i>46</i>
<i>Figure 4.32</i>	<i>Total Cost of All Parts Individual Traces.....</i>	<i>47</i>
<i>Figure 4.33</i>	<i>Total With Holding Cost Multivariate Result.....</i>	<i>47</i>
<i>Figure 4.34</i>	<i>Total With Holding Individual Traces.....</i>	<i>47</i>
<i>Figure 4.35</i>	<i>EOQ Multivariate Sensitivity</i>	<i>48</i>
<i>Figure 4.36</i>	<i>EOQ Showing Individual Traces of Sensitivity</i>	<i>48</i>
<i>Figure 4.37</i>	<i>Modeling Integrated with the Shipping and Overall Cost.....</i>	<i>49</i>
<i>Figure 4.38</i>	<i>EOQ with Daily Demand Fluctuation.....</i>	<i>53</i>
<i>Figure 4.39</i>	<i>Total Cost of All Parts.....</i>	<i>53</i>
<i>Figure 4.40</i>	<i>Total Cost of All Parts.....</i>	<i>53</i>
<i>Figure 4.41</i>	<i>Total with Holding Cost.....</i>	<i>54</i>
<i>Figure 4.42</i>	<i>Total Shipping Cost.....</i>	<i>54</i>
<i>Figure 4.43</i>	<i>Total Shipping Cost.....</i>	<i>54</i>
<i>Figure 4.44</i>	<i>Total Cost of All Parts Sensitivity</i>	<i>55</i>
<i>Figure 4.45</i>	<i>Total Cost of All Parts Individual Traces.....</i>	<i>55</i>
<i>Figure 4.46</i>	<i>EOQ Multivariate Simulation.....</i>	<i>55</i>
<i>Figure 4.47</i>	<i>EOQ Individual Traces Result.....</i>	<i>56</i>
<i>Figure 4.48</i>	<i>Total Shipping Cost Multivariate Sensitivity.....</i>	<i>56</i>
<i>Figure 4.49</i>	<i>Individual Traces of Total Shipping Cost.....</i>	<i>56</i>
<i>Figure-4.50</i>	<i>Total with Holding Cost Multivariate Sensitivity.....</i>	<i>57</i>
<i>Figure 4.51</i>	<i>Individual Traces Total with Holding Cost.....</i>	<i>57</i>
<i>Figure 4.52</i>	<i>Total Cost Multivariate Sensitivity.....</i>	<i>57</i>
<i>Figure 4.53</i>	<i>Daily Demand Individual Traces Sensitivity result.....</i>	<i>58</i>
<i>Figure 4.54</i>	<i>Isometric Drawing of Lead Acid Battery with Parts.....</i>	<i>60</i>
<i>Figure 4.55</i>	<i>Modeling for Assembly Complexity Index.....</i>	<i>61</i>

<i>Figure 4.56</i>	<i>The Results of The Assembly Complexity Index</i>	<i>63</i>
<i>Figure 4.57</i>	<i>Multivariate Sensitivity.....</i>	<i>63</i>
<i>Figure 4.58</i>	<i>Individual Traces of Assembly Complexity Index.....</i>	<i>63</i>
<i>Figure 4.59</i>	<i>Key Attributes of Unit of Assembly Cost for Fixed Automation.....</i>	<i>64</i>
<i>Figure 4.60</i>	<i>Modeling Sketch of Unit Assembly Cost for Fixed Automation.....</i>	<i>64</i>
<i>Figure 4.61</i>	<i>Unit Assembly Cost for Fixed Automation.....</i>	<i>67</i>
<i>Figure 4.62</i>	<i>Fraction of Machine Cost Influence.....</i>	<i>67</i>
<i>Figure 4.63</i>	<i>Influence of Average Cost Per Station.....</i>	<i>68</i>
<i>Figure 4.64</i>	<i>Unit Cost of Assembly Multivariate Sensitivity.....</i>	<i>68</i>
<i>Figure 4.65</i>	<i>Individual Traces of Unit Cost Of Assembly.....</i>	<i>68</i>
<i>Figure 4.66</i>	<i>Key Attributes In Modeling Unit Assembly Cost.....</i>	<i>69</i>
<i>Figure 4.67</i>	<i>Key Attributes In Modeling Unit Assembly Cost through Manual Assembly Processes.....</i>	<i>69</i>
<i>Figure 4.68</i>	<i>Modeling of Unit Assembly Cost Through Manual Process.....</i>	<i>70</i>
<i>Figure 4.69</i>	<i>Number of People.....</i>	<i>73</i>
<i>Figure 4.70</i>	<i>Unit Assembly Cost.....</i>	<i>73</i>
<i>Figure 4.71</i>	<i>Number of People Multivariate Sensitivity.....</i>	<i>74</i>
<i>Figure 4.72</i>	<i>Individual Traces of Sensitivity.....</i>	<i>74</i>
<i>Figure 4.73</i>	<i>Ram-up Physical Component Issues Key Attributes.....</i>	<i>75</i>
<i>Figure 4.74</i>	<i>Modeling Sketch of Ramp-Up Component Issues.....</i>	<i>75</i>
<i>Figure 4.75</i>	<i>The Ram-up Physical Component Issues.....</i>	<i>78</i>
<i>Figure 4.76</i>	<i>Physical Component Multivariate Sensitivity.....</i>	<i>78</i>
<i>Figure 4.77</i>	<i>Physical Components Individual Traces</i>	<i>79</i>
<i>Figure 4.78</i>	<i>Key Relation for Automatic Feeding.....</i>	<i>79</i>
<i>Figure 4.79</i>	<i>Modeling Cost of Loaded Magazine by Automatic/Manual Feed..</i>	<i>80</i>
<i>Figure 4.80</i>	<i>Key Attributes of Manually Loaded Magazine Manual Handling..</i>	<i>80</i>
<i>Figure 4.81</i>	<i>Total Cost of Assembly Workers.</i>	<i>83</i>
<i>Figure 4.82</i>	<i>Total Cost of Manually Loaded Magazine.....</i>	<i>83</i>
<i>Figure 4.83</i>	<i>Total of Automatic Feeding Cost.....</i>	<i>84</i>
<i>Figure 4.84</i>	<i>Total Feeding Cost Multivariate Simulation.....</i>	<i>84</i>
<i>Figure 4.85</i>	<i>Total Feeding Cost Individual Traces</i>	<i>85</i>

<i>Figure 4.86</i>	<i>Total Cost of Manually Loaded Magazine Multivariate Simulation</i>	85
<i>Figure 4.87</i>	<i>Total Cost of Manually Loaded Magazine Individual Traces</i>	85
<i>Figure 4.88</i>	<i>Total Cost of Assembly Worker Multivariate Sensitivity</i>	86
<i>Figure 4.89</i>	<i>Total Cost of Assembly Worker Individual Traces</i>	86
<i>Figure 5.1</i>	<i>Family of Utility Function</i>	85
<i>Figure 5.2</i>	<i>Forces acting on a Point</i>	94
<i>Figure 5.3</i>	<i>Equilibrium in Centroid</i>	95
<i>Figure 6.1</i>	<i>Porter & Lawler Motivation Model (After Porter et al. (1968))</i>	98
<i>Figure 6.2</i>	<i>Key Relations and Attributes of Porter Lawler Motivation Model</i>	99
<i>Figure 6.3</i>	<i>Remodeling of Motivation Theory for Performance</i>	99
<i>Figure 6.4</i>	<i>Value of Reward</i>	104
<i>Figure 6.5</i>	<i>Demonstrated Behavior</i>	105
<i>Figure 6.6</i>	<i>Satisfaction Level</i>	105
<i>Figure 6.7</i>	<i>Personality Traits</i>	105
<i>Figure 6.8</i>	<i>Multivariate Sensitivity of Reward and Satisfaction</i>	106
<i>Figure 6.9</i>	<i>Individual Traces of Demonstrated Behavior</i>	106
<i>Figure 6.10</i>	<i>Original Value of Reward</i>	107
<i>Figure 6.11</i>	<i>Perceived Rewards</i>	107
<i>Figure 6.12</i>	<i>Personality Traits</i>	107
<i>Figure 6.13</i>	<i>Multivariate Sensitivity of Satisfaction Personality Traits Focus</i>	108
<i>Figure 6.14</i>	<i>Reward and Satisfaction Individual Traces</i>	108
<i>Figure 6.15</i>	<i>The Demonstrated Behavior</i>	109
<i>Figure 6.16</i>	<i>The Personality Traits</i>	109
<i>Figure 6.17</i>	<i>The Demonstrated Behavior</i>	110
<i>Figure 6.18</i>	<i>Effort and Reward Probability</i>	110
<i>Figure 6.19</i>	<i>Satisfaction Level</i>	111
<i>Figure 6.20</i>	<i>Multivariate Sensitivity of Reward and Satisfaction</i>	112
<i>Figure 6.21</i>	<i>Sensitivity Analysis of Reward and Satisfaction Individual Traces</i>	112

LIST OF NOMENCLATURE

Q	<i>Economic order Quantity e.g. size of in number of units</i>
h	<i>holding cost per unit quantity</i>
λ	<i>demand rate known units per units time</i>
k	<i>set up cost in dollars</i>
C	<i>Total Cost</i>
Q	<i>Batch Quantity</i>
Cd	<i>Hourly Rate of the Direct work \$/ Hour</i>
TD	<i>Direct Machining Time</i>
Ct	<i>Hourly rate of Indirect Labour</i>
Tp	<i>Indirect labour time in hour</i>
Cs	<i>Hourly Rate for set up Time</i>
N	<i>Minimum Number of Machine needed for the system</i>
Q	<i>Daily demand of the parts/Day</i>
t	<i>Total production Time of Parts in minutes/parts</i>
Mr	<i>Machine Reliability in numbers of machines</i>
Ma	<i>Machine Availability in minuts/day</i>
n	<i>Number of operators</i>
w	<i>hourly wage rate of operators</i>
Q	<i>Annual production in units</i>
λ	<i>Employee turnover rate</i>
I	<i>Initial repetition of the replacement operator</i>

<i>F</i>	<i>final repetition of the replacement of the operator to overtake the pace of the line</i>
<i>T</i>	<i>Assembly Time per parts in seconds</i>
<i>Q</i>	<i>Annual production Volume per year</i>
<i>y</i>	<i>Acceptable Units percentage</i>
<i>N</i>	<i>Number parts per units seconds</i>
<i>fa</i>	<i>fraction of machine allocation cost per year</i>
<i>S\$</i>	<i>Average cost of machine per station</i>
<i>E</i>	<i>Efficiency of machine</i>
<i>C_{ass}</i>	<i>Complexity Index</i>
<i>D_{ass}</i>	<i>Number of Assembly parts pre or post DFA</i>
<i>RE_{ff}</i>	<i>Assembly related task efforts</i>
<i>H_{ass}</i>	<i>Information of assembly parts</i>
<i>N</i>	<i>Total Number of Assembly parts</i>

LIST OF EQUATIONS

$$\text{Economic Order Quantity} = Q = \sqrt{\frac{2k\delta}{h}} \dots \dots \dots (1)$$

$$\begin{aligned} \text{Minimum Number of Machines required} &= N \\ &= \frac{Q * t}{\text{Minuts/day Available} * \text{Machine Reliability}} \dots \dots \dots (2) \end{aligned}$$

$$\text{Size of the order Quantity} = N = \sqrt{\frac{2CY}{I * P}} \dots \dots \dots (3)$$

$$\text{Total Cost} = C = Q * C_d * T_d + C_t * T_p * C_s * T_s \dots \dots \dots (4)$$

$$\text{Cost of Feed Equipment} = \left(\frac{60}{F_r}\right) R_f \dots \dots \dots (5)$$

$$\text{Feed Equipment Rate} = R_f = C_f E_o / 5760 P_b S_n \dots \dots \dots (6)$$

$$\text{Relative Cost of Feeder} = C_f = \left(\frac{60}{F_r}\right) C_r \dots \dots \dots (7)$$

$$\text{Cost of manually loaded Maxine} = C_{mm} = (C_m W_a / S_n Q_e) t_{at} + W_a t_m \dots \dots \dots (8)$$

$$\text{Cost of Automatic feed} = C_f = \frac{C_f W_a}{S_n Q_e} T_{at} \dots \dots \dots (9)$$

$$\text{Unit Assembly Cost for Manual Assembly} = \frac{A\$ \times \text{No} - \text{People}}{Q \times Y} \dots \dots \dots (10)$$

$$\text{Unit Assembly Cost for Fixed Automation} = \frac{Fa \times N \times S \$}{Q \times Y \times E} \dots \dots \dots (11)$$

$$\text{No} - \text{People} = \frac{T \times Q \times N}{2000 \times 3600} \dots \dots \dots (12)$$

$$\text{Complexity Index} = C_{ass} = [D_{ass} + RE_{ff}] \times H_{ass} \dots \dots \dots (13)$$

$$D_{ass} = n/N - 1 \dots \dots \dots (14)$$

$$H_{ass} = \log_2(N + 1) \dots \dots \dots (15)$$

CHAPTER 1

INTRODUCTION

1.1 Research Background

The aim of this research is to identify and analyze those impacts which are led by contributing factors of complexity indices in the form of industrial sociotechnical system dynamics. The modeling changes with respect to design and process related changes which continuously develops ramp-up processes, within the expected life-cycle, while maintaining core aspects of production productivity and quality level. This study is conducted in the form of several diversified case studies covering many typical stages and aspects of manufacturing system design where the impact of ramp-up process becomes significant e.g. economic order quantity (EOQ) and cost. The example products and processes are diversified to emphasize that these factors are not specific to many particular system design. The purpose of the continuous ramp-up process design is to install the hard and soft enablers for the desired modifications in the manufacturing process due to the consistent change in customer demands or to maintain a competitive edge while maintaining the productivity and improving quality levels. Therefore, non-linear system dynamic models of integrated continuous ramp-up processes and with accurate complexity indices helps not only in producing accurate products in precise quantities within the limits of the estimated timeline.

This research work aims at studying proactive linear models of different ramp up issues and transforming them into system dynamic from the static models to the dynamic models so that the evolution of the issue can be understood better in the time horizon. In this work, various case studies also highlights the dynamics which can result from perturbation of certain parameters and how this will affect the whole system and related sub systems when they together form a system of systems (SOS). Next, in order to understand the assembly complexity this can be done due to its related parts information cognition efforts etc. But the design for assembly (DFA) principles and design for manufacturing (DFM) are the main important issues by means of which the connections between pairs of parts need to be reduced, firstly and later manufacturing is made. These issues which effects production processes are worked out. From the dynamic models it

has been concluded that the ramp-up issues are not limited to simple issues of the sequencing of change in assembly software, but it becomes more complex when product data model which contains the entities and their respective attributes, which are commonly presented in different product description entails more complexity when they are integrated. Besides, one concern in this regard is that different attributes of design and geometry of the product which provide the information about certain level of tolerance dimensions for some specific part geometry. Suppose some description is in Two dimensional (2-D) drawings while others are in Three dimensional (3-D) drawings this would affect the ramp-up process because of the tolerances of the different mating parts. The higher the complexity level in the manufacturing processes is in the product design; the higher the complexity level will be in data modeling and fabrication. On the other hands, lower number of complex parts will result in a lower level of complexity overall.

Moreover, core issues of the ramp up like learning for product and process change, quality and inspection, are necessary to be given focus of attention as dynamic models makes to understand the behaviour pattern and the intensity of magnitude for different variables and constants. This gives a more accurate model than the static model, and the effects and feedback of the system is clearly visible. Similarly, if the labour is not properly trained to adapt to changes and variety in the process then the good outcome will be in doubt. It is pertinent to note the fact that the production assembly may also suffer from reliability problems as well as the complexity and extra cost of sensors integration. Finally, with regards to the motivation theory, and its respective impact, a comprehensive model is introduced which highlights the major impact on the motivation with given intrinsic and extrinsic reward to the labour. Next, in order to understand the behaviour pattern of the labour and personality theory impact which keeps the labour motivated for the sake of error free tasking, management has a role to boost the morale of company's employees and have a reward program to make the labour feel confidence as good work is rewarded. For instance providing vacation packages, cruise trips recreation etc., or other incentives would keep the employee confidence to grow and be satisfied. The results of the model show us the fact that changes in behaviour and similar patterns of behaviour will be the outcome when a particular parameter is perturbed. The intensity of the magnitude signifies the strength of the impact on a system.

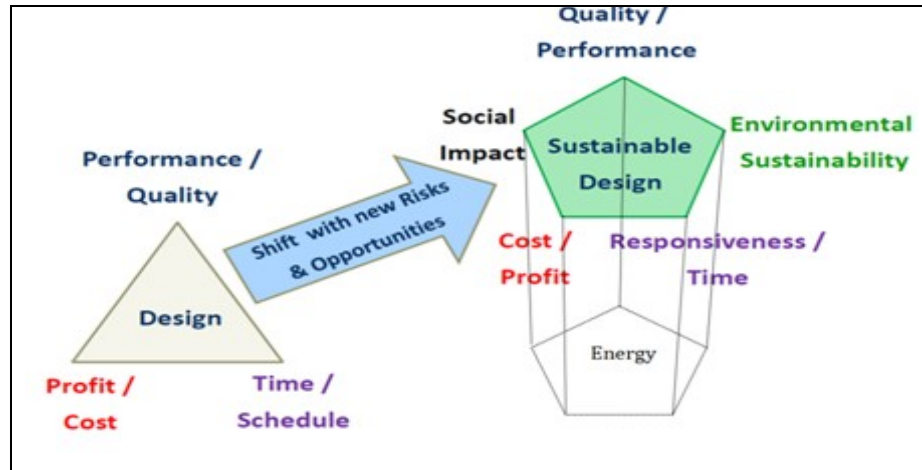

Figure1.1 Extended objectives of Design for 21st Century (ElMaraghy 2013).

1.2 *Status Quo of Sustainable Design*

Engineering design became very complex in the 21st century. It is aptly remarked by ElMaraghy (2013) in his key note address mentioned that modern industrial design has three (3) main pillars. These include the element of cost for profit gain. Next, is the minimum time for maximum output and productivity by managing scheduling. Moreover, measuring performance of the design using quality and production yields as an indicator. These were the domains of core importance but recently a shift has been observed to a new level of “sustainable design” into a pentagonal prism of pillars at the base is the embedded energy which is involved in all of the extended pillars, as illustrated in Figure 1.1. No doubt, this has invoked new risks and opportunities. But this new representation has its own emphasis as such that the first and the foremost importance is the environment and sustainability which are the new challenges of the 21st century and are now part and parcel for success of any industrial design and businesses. This is due to the growing public awareness and the government regulations and standard. Next is the responsiveness with agility, as a matter of fact the changing dynamics of the market dictates that the producers to act and respond to the quick changes. Otherwise non-compliance to the environmental regulations and standards they will be out at risk. Moreover, there is balance between the cost and benefit from products and services which are now a liability of all stake holders as such to do the need full accordingly in order to make the planet to be handed over to next generation without causing harm to the natural habitat and resources. Furthermore, in this context off course, quality and performance will remain the part of design for production and

reliability for the end user who is willing to pay for the product and services but an integrated dimension of the risk focusing the triple bottom line provides the insight on the product sociotechnical aspect. Lastly, but not the least, the social impact of the design and services is very important and needs to be given prime consideration too, which in fact was missing from the engineering design previously.

1.3 *Status Quo of Sustainable Production*

Dornfeld, (2012) states that and I quote “the driver for this big change is to include the true cost of the production of a product from resource extraction to end of life and reuse or recycling in the cost of the product”. He explained, the fact that if the associated cost due to social impact owing to the environment factors is added with the life cycle disposal cost along with true cost of the embedded energy to meet all these requirements like material labour union, then the cost of the daily utility items like air plane tickets, trains, automobile, taxi cabs etc. actual costs can be ascertained. In other words, external factors to the product are evolving and they are in continuous evolution invoking further complexity. Furthermore, the complicated analysis based upon the life cycle analysis, if performed on each product, then the system of systems (SOS) level impact could be realized in the form of the reduced carbon foot print.

1.4 *The Problem in Focus*

Product development is the core phase of manufacturing research in the system domain as the features and the quality evolves in the product so as the allied integrated systems, as well in terms of scale, scope and functionality level. This evolution took place over decades of research based upon competition among different competitors of similar nature featured product which have variety of parts. In fact these features in the product design and manufacturing process level, breeds complexity. The complexity involves in to hard and soft enablers of the product in terms of the operational level, design level, process level, system level and worst of all at assembly and disassembly levels which are due to the environmental challenges attached to the product life cycle. This provides big challenges to recovery and recycling cost. Modern manufacturing is based upon two basic pillars of hard and soft enablers which provides the necessary support to adjust the changeability in the product due to variety and very often due to short life cycle of the

product; this is achieved with ability of fast ramp up to response to market changing dynamics. Due to tight profit margins and diverse customized and personalized, niche markets “survival of the fastest to customer” is the philosophy behind every change in the product. This increases not only the company’s reputation as a successful company but also this notion that which one is to holds first the new patent claim of their new invention and design as well. Therefore, the production ramp-up phase becomes critical and presents continuous challenge for success of the whole enterprise operations. The new product systems are evolved not only internally but externally as well where response to the green markets and making good alliance with the similar supply chain oriented companies provides the effective control of the product development for new markets. According to ElMaraghy et al.(2012) a system of systems (SOS) emerges from the inter action of all these systems complexities. In other words, ramp-up production has now become a continuous process of different systems when they are integrated together to achieve a goal then the real and imaginary complexity affects the performance of the system. Besides these facts, the ram up complexity can be time independent and dependent while focusing on systems according to Suh (2005).This research work is an attempt to conduct the system dynamic based study of different sort of complexity involved in the production ramp up process which has its roots in its evolutionary effects resulting in to a complex dynamics and that has further link to the dynamic in sociotechnical domain. In other words, the effects on the sociotechnical system reflects the better analysis if system dynamic modeling is performed in order to understand the holistic big picture over the time domain to ascertain the effects of relative variables and parameters involved for decision making. Geels (2004) has mentioned and as it is clear, that there are three basic interrelated elements which are connected to perform a useful purpose, these elements include sociotechnical systems, rules and actor interact as such those for instance human actors and social groups and organizations are one of the core elements. The reason is the sociotechnical systems do not work on their own, but through the involvement of human actors and organizations. Here it is very important to note that this research suggest the fact that human actions and the rules procedure of organization domains are different systems which when interacts and connected for some particular purpose forms a system of systems. Apart from that Geels (2004) describes that these

actors operates in the context of rules. Their perceptions and inter actions are governed by means of rules and laws. While on the other hands these rules are also developed by the actors who carries and reproduces the rules as well. Moreover, sociotechnical systems artifacts and material conditions form a context for actions, they infact enable and constrain actor network theory. Furthermore, the rules are not embedded in the minds of the actors but also in the artifacts itself as such the labour scripts. Lastly, sociotechnical systems; artifacts and material conditions shape, rules, frames, standards etc. interoperative flexibility is constrained by technical material possibilities.

1.5 Statement of Hypothesis of the thesis

Statement of thesis: *"A system, which organizes and manages itself on scale, scope, function and structure levels forms a complex system of systems, Non-linear system dynamic modeling is needed to analyze and understand the very large scale product developments which evolved into a complex sociotechnical systems"*.

A typical example of this large scale system is complex transportation sectors traffic engineering system and law enforcement integrated with fine deposit to the on line banking system for mistakes committed by a driver on the highway in low or high traffic volume for which automated camera on the traffic signal gives a corroborated facts based digital picture. This is the example of emergence of a very complex large scale, scope, function and structure based sociotechnical system of new millennium. Similar analogy is drawn in this context, while focusing the production ramp-up phase in the typical manufacturing system, where the integration of hard and soft enablers makes the final product in minimum time to target the market forms a complex sociotechnical system that customers need for product development which address common issues associated with the quality and productivity. Furthermore, variety in products due to niche market of mass customization and personalization produces complexity in production ramp up. Finally, the statement of the dissertation describes the fact that very large scale product evolves into a complex sociotechnical system, which organizes and manages the interaction when they are integrated together at function, structure, scale and scope levels. Therefore, this forms a system of systems (SOS) which manages the emergence resulting from

interaction of these systems that can be managed by the system properties of resilience and flexibility at the function, structure, scale and scope level.

1.6 Research Objective

This research views manufacturing as the means to satisfy the dynamics of the market with its ever changing capability of adjustment in terms of reconfiguration and flexibility of its hard and soft enablers whose response to scale, scope, structure and functional level makes the final product to reach its potential customer in minimum time. No doubt, variety in product due to niche market of mass customization and personalization produces complexity in production, but the change in the design and features requires to be accommodated by the manufacturing capability of the machine tools as well as the fabrication technique and expertise involved. This occurring change of variety of the product on the same production line involves a continuous process of labour learning as product and process change which occur, in hard and soft enablers or so as the integration of the same on the existing set up produces sociotechnical complexity. Similarly, new product development now involves the evolvable sociotechnical factors in ramp up phase and in technical parameters which are different from the Taylor's era visions. New issues are to be considered to keep effective handling of the labour psychology for motivation to adopt the changes in hard and soft enabler and to conduct manufacturing processes successfully.

1.7 How the objective is to be achieved

In order to understand the crux of the issue this research focuses on developing various case studies based on linear models by transforming them into system dynamic modeling approach. This will describe and elaborate the long term effects of emergence and impact due to system interaction for production ramp up for the success of the business. Hence, ramp up phase not only provides the very insight of the forthcoming scenario but also helps in understanding the time dependent and time independent complexities due to integration of the hard and soft enablers. This has its roots in static and dynamic complexity. In this context, a frame work as shown below in Figure 1.2 is being adopted on the basis of system of systems (SOS) where as each system evolves in to separate independent sub system but altogether functions as system of systems (SOS). Product

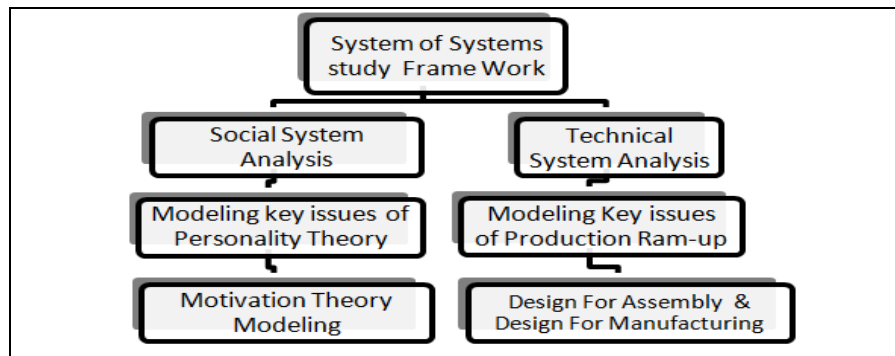

Figure 1.2 Frame work for effective production ramp up.

variety and production mix produce serious affect due to competition in the market. Product variety due to niche market of mass customization and personalization have produced the complexity in the production at the design and process levels during the ramp-up period. The ramp-up period has prominent sociotechnical elements which are encountered during hard and soft enabler management and integration due to changes in existing design and process or introducing whole new product line. Whereas the goal to reach customer fast, while new patent is filed and also the fact before the competitor dumps its product of the similar features in the market, requires a very quick and fast ramp-up. The technical efforts needed to make the ramp-up appear to involve a few core sub systems whose analysis is very vital for the production ramp-up analysis. These include the quality and learning cost; design for assembly manual and automated feed analysis complexity for new product introduction or change in design for quality and safety standards etc. In this research, novel system dynamic models have been created by transforming the static models to explore the ramp-up issues. In contrary to previous attempts that used linear models using simple arithmetic equations which in fact shows just one side of the state of the system and does not provides the long term holistic projections. Apart from that, this research provides a novel approach and its corresponding dynamic system of systems (SOS) study by finding solutions for challenges of the production ramp-up, due to product complexity in assembly analysis; due to relative dynamics and their effect in understanding of the system; etc. The second key contribution is the proposal and design of novel system dynamic models to model and understand the complexity of process and product due to economic order quantity (EOQ) and effects of assembly complexity and their related cost.

1.8 Organization of the Dissertation

Keeping that in mind the following are glimpse of the arguments in support of the thesis statement and to understand the real crux of the issue. As such Chapter 2 discusses the dynamic context and describes the systems acquiring the system engineering by limiting its perspective in system analysis especially while designing large scale system design which evolves into a global system of systems (SOS) for energy transportation and communication has been discussed. Further partially designed and partially evolved systems, characteristics of sociotechnical systems and their respective analysis and simulation models has been presented as well. Besides, also in this context what are the confronting challenges for sustainable market competitiveness and as well as the manufacturing and product end of life strategy and environment. Later the crux of the issues which involve the entropy and work in human organization are highlighted along with the environment and resource sustainability and how the sociotechnical systems model which is utilized in managing the dynamic business. In Chapter 3, the literature review has been presented targeting the ramp up scenario and research gap areas to pin down short-comes to perform further analysis and throwing light on gravity of the issues. Chapter 4 presents the elements of effective production ramp-up analysis. It also has expounded with the extension of the work done by the pioneers in the field by transforming and using system dynamic approaches to understand the behavior patterns and the affect of different parameters perturbation in the system behavior along with its magnitude of intensity. Chapter 5 goes into more specific and pin down the major issues related to the production ramp up with regard to the labour learning and knowledge transfer besides the quantitative issues of the inspection and the quality for maximizing the potential yield of production capacity. Finally, Chapter 6 is devoted for the sociotechnical management issues related to labour psychology by describing the motivation theory. Besides, the motivation theory remodeling of the Potter and Lawler theory have been performed to make a case for system of systems challenges and understanding their complexity. At the end Chapter 7 presents a summary of this project results to-gather with the conclusions and recommendations.

CHAPTER II

MOTIVATIONS AND SCOPE

2.1 System Engineering Focus

Engineering systems are at the intersection of the engineering management and the social sciences. Designing complex technological systems require the traditional engineering knowledge and the awareness of societal norms. The manufacturing challenges today are the rapid technological change, competitiveness, and relative complexity. Only planning ahead and innovation with competitive edge is not enough, it is also required to keep room for the unexpected changes in the plan, ability to learn and adaptability to change with customer demands in scale and scope, state, complexity, integration, architecture, resilience, affordability and sustainability. Social factors should also be included. Such new product design integrated to a larger system with the tremendous complexity is aptly described by De Weck et al. (2011) as system of systems (SOS) and so as due to globalization a global (SOS) is also emerging.

2.2 Criticizing the Evolutionary Effects of Innovation

In context of Innovations the past century, has provided telephones, automobiles, railways, television, etc. which are now complex systems. In fact, these products are rapidly and continuously evolving. Next, components and technologies for the products such as computers, cars, need to have changeability as an integral part of the development processes. However, if the underlying infrastructure networks fail to anticipate changes, it can result in a mismatch between technological progress and the backwardness of infrastructure. In fact, the emergence of SOS fills the need of communication and inter-relationships between various systems. Several independent systems are connected together to perform some purpose which can also be done independently but coupling them together represents SOS. A policy development or enforcement may not directly affect the functionality of the product but it can affect the usability. For example, how much load is allowed on the hanging bridge at a time to avoid fatality, etc?

2.3 Understanding the Nature of Systems and System Thinking

The systems approach has brought considerable insight and benefits to understand in almost all fields of human endeavor. These may be of several types, including, but not

limited to symbolic diagrams highlighting the essential features of some situation or problem space, looking particularly at paths of communication, lack of communication, areas of conflict, and so on. These are associated with so-called soft systems, but may be of much wider application. These dynamic systems encourage the exploration of the dynamic aspects of problem space, and of interacting open systems which exhibit properties of their interactions within the simulation.

2.4 Context of System Engineering

Systems engineering is an interdisciplinary approach for a structured, disciplined, and documented technical effort to simultaneously design and develop system's products and processes for creating systems to satisfy the operational needs of the customer. It transforms needed operational capabilities into an integrated system design through concurrent consideration of all life cycle needs. As systems become larger and more complex, the design, development, and production of such systems or SOS require the integration of numerous activities and processes. Systems engineering is the approach to coordinating and integrating all acquisition life cycle activities. It integrates diverse technical management processes to achieve an integrated systems design.

2.5 Knowledge based Complex System

ElMaraghy et al. (2012) describes that the complexity and diversity of continuously growing engineering knowledge. All companies have organized around one or several engineering fields to develop and manufacture devices to meet the needs of the commercial market or of system-oriented industry. The development of interchangeable parts and automated assembly has been one of the triumphs of the USA industries. The convenience of subdividing complex systems into individual building blocks has a price i.e. the complexity of integration. Each building block must fit as desired physically and functionally with its neighbors and with the external environment. It should also produce the exact response as expected. The physical fit is accomplished at inter-component boundaries called interfaces. The functional relationships are called interactions. The task of analyzing, specifying, and validating the component's interfaces with each other and with the external environment is the province of the systems engineer, as described by the Kossiakoff et al. (2003). A direct consequence of the building blocks is the concept of

modularity. Modularity is a measure of the degree of mutual independence of the individual system components. An essential goal of systems engineering is to achieve a high degree of modularity with simpler interfaces and interactions. The process of subdividing a system into modular building blocks is called "functional allocation" and is another basic tool of systems engineering.

2.6 *Analyses of a Large Scale System Design*

According to De Weck et al. (2011) the core activity of the engineering discipline is the design monument. Most engineers consider the design as the most personally rewarding activity. As it is the human process of synthesis and integration of technical knowledge (as oppose to analysis and decomposition, meeting the human needs) by creating actual artifacts as well as algorithms process and systems that meet these needs. The importance and the excitement found in engineering design involves the inherent creativity in bringing forth truly new and useful artifacts, algorithms, processes and systems. The basic definition of the engineering design establishes it very clearly as a sociotechnical process because of the interaction of a human (designer) and the technology as a key enabler and to meet human needs and wants. The sociotechnical aspect of the design in general determines the needs, managing groups of people, etc. It also shows a significant affinity with the broader concern of engineering systems which is beyond technical aspect of the design alone. Furthermore, designing an engineering system involves significant extensions to the traditional design process applied to the less complex systems. The scale and scope is important in the design and development because with the increase of scope, the complexity as well as the number of the opinionated people in the design team also increases. Functionality is the critical factor in design. The increase in complexity due to increase in scope tends to design multi-functionality which in turn increases the complexity and another self reinforcing loop of the system in focus. Also, the structure is critical because at smaller scale design, it is possible to ignore the layers levels and decomposition approaches associated with the structure and attempts to architect when scale of system increases. Inaccurate system complexity estimation and time of evolution of sub-systems occurs with change in scale and scope affecting the legacy elements of design and to use life cycle analysis. For a larger system there are no longer seems to be a single design and new role and responsibilities are expected. Therefore, Siddhartha

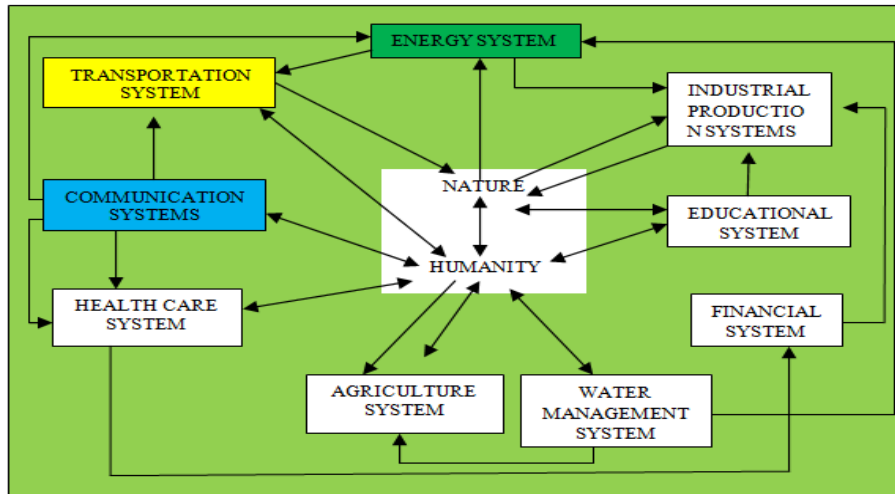

Figure 2.1 Evolution of Global SOS (adopted from De Weck et al. (2011))

(2010) suggests the process standardization, and to list the factors that are essential to consider.

2.7 Evolution of System of Systems (SOS)

The term SOS appears frequently and implies the existence of distinct classes within systems which represent distinct demands in design, development, or operation. Maier (1998) defines the term system of system and establishes on the basis of two basic criteria for distinguishing them from other large scale complex systems which are operational as well as the managerial independence of the concerned system .

2.8 Emergence of Global System of Systems

The systems which have been created to help our needs such as energy, transportation and communication, the food production, water management and health care are being transformed by new technology and are becoming increasingly connected to each other as shown in Figure 2.1. This is the beginning and emergences of system of systems (SOS) where the boundaries among the systems are increasingly porous. Figure 2.1 shows three fundamental spines which have been connected such as energy, transportation and communication on the upper left corner while the humanity and the nature is in the middle which means the collective human population and will and by nature the evolving land oceans and atmosphere of our home planet. Humans play very vital role in the natural systems as designer, operators, users, and decision makers. Learning and

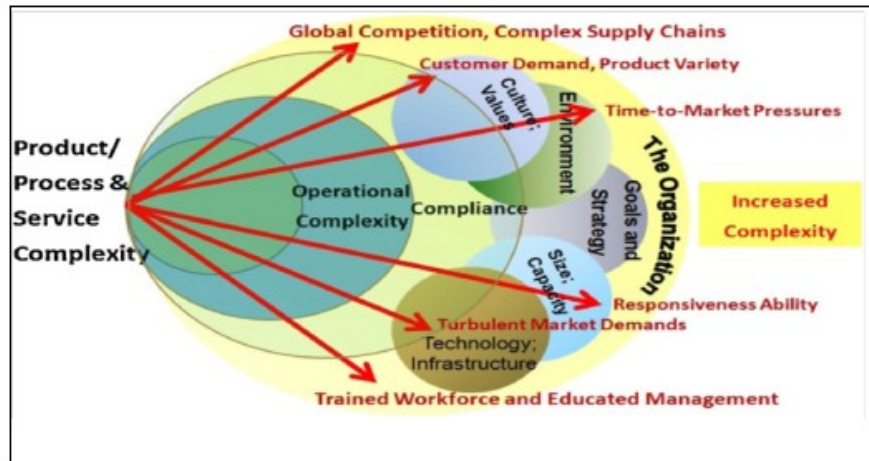

Figure 2.2 SOS Model Adopted from ElMaraghy et al. (2012)

education is the key enabler of all and long-term success. Other views that future of engineering system will be more like a broker who will be having the ability to translate seamlessly between the more established fields such as technology focused engineering, management, economic, and policy. This more federated approach would at least require to develop a common frame works and models and potentially system languages in such a way that it will help facilitate the engineering of sociotechnical system in more collaborative way. Lastly, the unfolding of the 21st century and the more distant future will be shaped by our ability to understand mold and improve the complex systems which we create in harmony with nature and with ourselves. When operating as an integrated system, the network can exhibit network wide emergent behavior. The Model shown in Figure 2.2 by ElMaraghy et al. (2012) describes system and systems (SOS) basis for new product design and concludes on sustainable product and process design, which ends up in corporate social responsibility as any activity created with intention to create a new values in product by inciting relative complexity, which evolves in to a new system. In fact, every human activity to create a value must also entails some entropy in atmosphere, hydrosphere, biosphere and geosphere which in fact is the crux of the issue to sustain the product as well as the process design by means of effective R& D. As wealth creation for growth is the motto but not at the expense of the resources what we have and the resources what we have to have for our future generations. This is in theory a conservative philosophical point of view, but liberal theory of so called social justice strongly advocates this as well.

CHAPTER III
LITERATURE REVIEW OF RAMP-UP PLANING

3.1 *Ram-up Manufacturing Conceptual Preview*

The concept of ramp-up is associated largely with the change in product design and process by means of soft and hard enablers to attain the desired production goals. The enablers of the product and process change to happen are at hard and soft enablers. Over the decades of research and development automation has brought numerous challenges to the manufacturing. No doubt, the grand challenge to attain productivity and quality is achievable but on the expense of the effective sociotechnical system only. Competition breeds the innovation so that product the cycle is becoming sharp and thin. This is due to the fact that the product life on the shelf is reduced to minimum when a better product than the existing ones are brought with good new features in the market. But the factors which influence this outcome are the ramp-up phases; the shorter it is the quicker to respond to the rapid changing dynamics of the market. Ordinarily, it is considered by the research people that it is the technology which makes the changes to happen; but in fact it is the people as well who educate and learn and change themselves or adopt the changes which are inevitable due to competitiveness phenomena to survive in the market. Processes are now complicated and machine tools hardware and supporting software integration for adjusting every now and then changes are complex. Therefore, variety of anything in designing of soft module as well as the assembly of the physical product where more parts are participating is the invitation to complexity to emerge at any level of the shop floor from material handling, scheduling of the component, etc. all together become evolvable systems to form a complex sociotechnical system where dealing hands have to learn to meet the desired goal and achieve the maximum output of the system. A common observation is more a part or process remains in the system, it will create complexity no matter what either at the structure, scope or functionality level but does when change is inevitable due to new development in product and process design. Thus flexibility on the part of the system is highly desirable to respond to that change with resilience and agility. Ram-up phase is a continuous process which has to have the effective hardware and software support. But the human element of the system is very important to consider beside the technology element. This is because human element is

unique and part and parcel of the system success. Cost is very challenging, more time spend during the ramp-up means more cost burden on the product concepts provided by Gunther et al.(2005), Dashchenko (2006), Reinhart, et al. (2007), Laurène (2010) and Lanza and Sauer (2012).

3.2 Need for the Ramp-up

The need for the ramp-up is very simple and straight forward to survive the business activity in the global market. Where the demand of the customer now holds the variety needed and besides the personalization of the niche market has emerge. It is a challenge for the competing product manufacturer to explore the change and bring the challenging product for their customers to satisfy their need.

Therefore, ramp-up becomes the core activity of the production and manufacturing in a sense that the first run of the production for pre full swing production volume is necessarily involving real and imaginary complexity besides the static and dynamic complexity at the operation and design levels. However, to cope all these it is very imported to have a system level perspective by changing lenses of the integrated scenario with deep rooted system thinking by complete understanding the core notions of cause and effect. Quality and lower price does not match always but when the markets picks up the productivity brings cost down to an equilibrium level and eventually leads to the greater profit margins.

Better man machine interface is considered as a one big aspect of the human side of the manufacturing but this research suggest that the learning and motivation are the real human aspects which are sine quo none for the fast pace rapid growth throughputs ramp up. While production is involving a product mix on the same manufacturing and assembly line where as the parts and process or say the job design should be based with extra care. Lean processes are good but not at the expense of the proper compensation to the man and the machine who handles the product and process. As social capital in the form of the trained human labour is very important, as together they create new products this fact cannot be ignored. De Weck et al (2011).

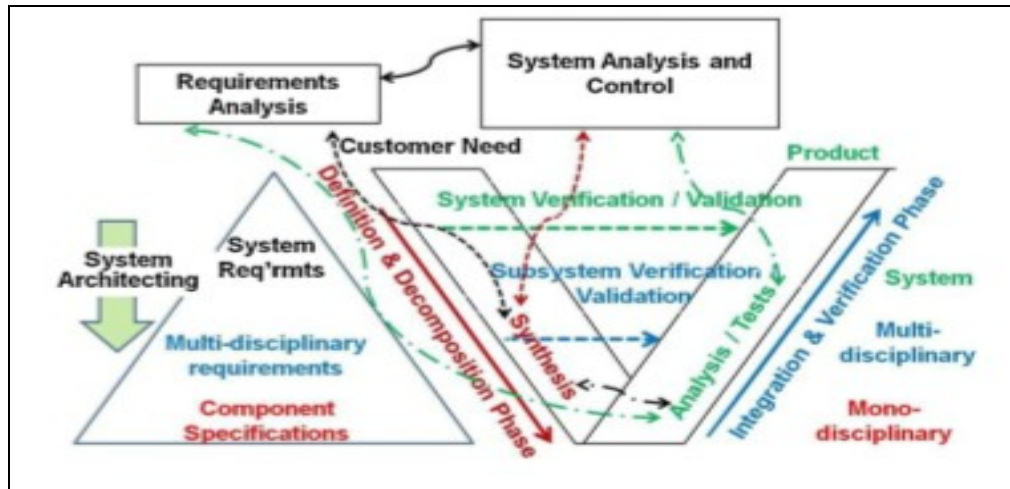

Figure 3.1 Complex Product/System Development Process V Model (adopted from (El Maraghy (2009))

3.3 System Engineering Perspective of Rapid Ramp-Up

According to Koren (2010), the ramp-up is defined as "Ramp-up period" which is the transition period of time when it takes a newly introduced system or reconfigured manufacturing system to reach its designed, sustainable, long-term levels of production in terms of both throughput and part quality. He also emphasizes on the fact that if the production systems are made more reconfigurable, then this eases the task of their functionality and layouts could be modified more frequently. It is pertinent to note the fact the ramp-up process includes embedded stations for dimension verification and diagnostics of the finished parts and products; as an example, the laser triangulation sensors measuring auto-body dimensions on the auto-body assembly line for quality and standard parts. The problem which is identified in this context is the fact that measurements are utilized for subsequent error calibration and compensation. Moreover partly, sensors are utilized and hence faults are detected and diagnosed to avoid occurrence of problems on the assembly line. These issues in fact can lead to serious quality and manufacturing problems which will surely imparts the assembly problems. Therefore, reconfigurable systems must be designed to include product quality measurement systems as an integral part of the system diagnosability characteristic. Finally, ElMaraghy (2009) describes integrated process for multidisciplinary design by using V-model by Forsberg et al. (1991) and Muller's pyramid (Muller's (2011)); as shown above in Figure 3.1 where the left part shows the design phase and right part of the

V shows the verification This holistic design frame work is very helpful in complex product development.

3.4 Critical Literature Review and Research Gap

Previous researchers like Gausemeier et al. (2005) points out about the long ramp up time for production system. They highlights the fact that hard and soft enabler of the manufacturing system should be coordinated effectively otherwise the problem persist. The author explains the core trouble areas as machinery, electronic and troubled software, But failed to identify the back bone reasons behind it, which are design for assembly (DFA) and design for manufacturing (DFM). However, they shed some light upon technology up grade or design up grade, in part or feature or new user interface is one of the aspects to cause troubles. Besides, time consuming ramp-up process is long testing of hardware in combination with the not yet tested control software. Which is primarily a mechatroninc issue.

Ceglarek, et al.(2004) explained the concept of time-based competition in manufacturing and design based on a review of ongoing research related to stream of variation methodology. But does not recognize the fact, that the variety and the market pull are core aspects for the product accelerated acceptance by the customers. Contrary to the fact they recognized that ramp-up stage of production is helpful in predicting misalignments and hence determines the degree of mismatch in the assemblies, by diagnosing the root causes of errors by means of making comparison with the components actual measurements. But in fact, this is due to the fact that occurs due to the design installation, maintenance and Supplier related problems. However, they had aptly pointed out the fact that due to integration of the new feature or module of a product and process design in a pre-production simulation, Stream of variation analysis (SOVA) is regarded as a helpful technique. One reason for this is that it is used to investigate the individual assembly level errors which contribute to all kinds of dimensional variations, that can result in or out-of-tolerance parts and products which occurs due to design, installation, maintenance and supplier related fluctuations and problems. Therefore, on the basis of the SOVA model and product measurements, it is capable to recommend solutions.

Reinhart and Wuñsch (2007) have explained the fact that how control software work for two purposes, firstly in order to take over the initiative in system design and later to do the needful of performing, those are important activities in the design process of production equipment. The author did tried to present a concept based scalable simulation which concludes upon a method for the economic application of virtual commissioning. But the fact is that faster ramp up reduces the cost burden on the product and so as the value attached to it can be translated to the customer. But this is depending upon the software system how much that has been improved to communicate with hard ware.

Ceglarek, et al. (1995) have described a methodology for assessment of dimensional failure attached to the automotive body. The dimensional variation of initial level of 8.5 mm to 2 mm has been studied. But their finding of the study imply that dimensional variation reduction process should be pre established at the beginning of the product development so that problems can be identified and corrected during pre-production phases. This is because of the use of a portable CMM and does not rely upon the statistical quality control and takes its own measurement.

Lanza and Sauer (2012) described an optimization technique which forecast those personnel requirements during ramp-up by taking into account the dynamic planning variables and organizational basic conditions. Their method calculates and supports the decision maker to calculate the necessary manpower for every single ramp-up phase and to realize the economic optimum. This work presented integrative simulation model that provides scenarios for the employment of human resources at every instant of time during the production ramp-up. This differentiates those elements which affects the integration of time-variant factors such as like learning curves.

Von Gleich et al. (2012) has discussed the scalability of production principles for a fast ramp-up; as well as advanced methods, processes and tools. They have presented a 3-cycles approach which is used to note the unintended disturbances and deliberate changes on the overall maturity. They have discussed also the risk during ramp up. In fact their approach is based upon the customer gating method which is developed to reduce local optimization and produces chain oriented behavior which makes it helpful for analysis of different phases of a ramp-up for a new aircraft model.

Matta et al. (2007) has presented an analytical solution for capacity planning which is based upon Markov theory. They presented the model and the optimized solution taking into account the effect of the ramp-up phenomenon. But their analyses prove that ignoring the ramp-up effect in the decision process can lead to significant increases in overall costs. In fact their solution is based on optimal boundaries representing the optimal capacity expansion and reduction levels, which explicitly considering production ramp-up.

Lenflea, et al. (2007) their work is descriptive and stresses on the fact that qualitative design should be made in the pre production phase so that later harmful effects impairs the much needed performance and so as the envisages of changes. However, the management functionality becomes very crucial but problems structured in this phase are unavoidable. Moreover, the knowledge base which is acquired helps and initiates guidance in reality. However, Lenflea, et al. (2007) research does help in understanding the sales of the product and its related learning curve. It also imparts light on the new product development during the design process. Next, Lenflea, et al. (2007) emphasized on products sales and effective management of sales which in fact produces good effects on innovation and services attached to the product concern.

Ball, et al. (2011) explored the knowledge which is specific to the capacity and learning and reviews how current work can be combined to develop the architecture for a modeling tool for engineering product ramp-up. This is in fact a reviewed work and looks into the issues but failed to address the design and system level issues which are directly influencing the shorter life cycle and increasing complexity of the product process at hard and soft drivers where changes occur for in ramp-up phase.

Schuh et al. (2009) described the situations of the ramp up focusing on the demand of design in developing market . Their work discusses the state of the art and strategies to optimize the profit margin as well as complexity of business processes. Thereby, this work has provided an insight into a link between the forecasting of labor requirements and learning curve theory that is lacking in the literature. The critical approach addresses key areas for successful management procedure. As such product ramp-up strategy, ramp-up planning and ramp-up evaluation using benchmarking technique. But it lacks the

analysis from the complexity of evolvable design of the product and its variety affecting the hard and soft enablers.

Next, finding of this research suggest that it has been a recognize fact that the researcher have to ponder on specifics of the issues concerning mere identical character of the whole ramp up process but should emphasize the planners to control the process to make decision after the analysis of the situation. In this context notable work just purports our attention towards the disruptions in the process; pace with which the work is accomplished and the methodology involved there in is regarded as the core element of the ramp up process management. Baloff (1970) and Almgren (1999 and 2000), were the ones who have advocated the afore said factors too. Following are the some of the aspect of the gap area analysis which is further explained as such:

- (1) That, ironically the design consideration which influences the process variation was not the part of the study. Therefore, the DFA and DFM consideration are one of the core of managing changeability in the design as well as the process. On other words, the product related gap area which is now after the high tech prototyping involves the digital and software related issues which are then translated to the production line and enables the production. Other researchers identified the criticality of the lead time to market and so as the involving product quality which went under change Cohen et al. (1999) and Bayus (1997) work in this direction is off importance. But these fundamental works also lack the core reason to improve the inspection and the quality of the assembly in focus. Next, in fact it is the reality check on the ground which is hardware has been the fundamental for the quality and increasing reliability.
- (2) Moreover, High volume production has its own merits and demerits with their given competitive market. But looking the ramp up issues related to the low volume producer the issues are more important where the integration of the latest stat of the art technology reflects the fact that to achieve the promising results one have to focus on use of the sociotechnical issues in the assembly which involves the efforts and cognitive related issues and so has to be the part of the design and partly process issue which has been ignored.
- (3) Furthermore, the change in the process and the product design or the feature

invokes the software to communicate with new changes with the relevant hardware or machine tool or jigs etc. In this regard the learning comes into action which is a very important influencing factor for effective production ramp up. Learning cost and learning index are the parameters which are the core elements to understand the impact which is a very helpful tool. This research emphasizes suggest that primary consideration for the ramp up phase is to be considered.

- (4) Finally, Sociotechnical analysis of the assembly is one of the aspect of the production ramp up but the most important is the role of the technical management and the labour coordination which embraces the success in the sever shorter product life cycle which needs the continuous improvement in the design. Therefore, labour behavior impacts, improvement and rewarding them through intrinsic and extrinsic reward will be an added advantage for creating a win-win situation for both the employer and the employee. This research suggests that this can be achieved through pulling the dynamic behavior by applying the motivation theory. Financial capital is one unique perspective which provides the soft and hard enabler to modern state of the art manufacturing. But the human capital and its knowledge base is indeed has its own vital importance which is lacking in plethora of the literature to study the dynamics and its impacts.

Following key words search which have been made and the results are in metrics format these key words are as such: Life cycle of product, Frequency of ramp-up, Commonality of the products, Plate form technology, Product Complexity, Product variety, Product architecture and technology, Production method and technology used, and Industrial Set-up. It is pertinent to mention here the fact that Dangayach et al (2001) have detailed some of the aspect of the research and its diligence as it has been described in his work as research methodology for classification of research, categorically the conceptual and theoretical, descriptive, mathematical, empirical and explanatory surveys. It has been found that there is plethora of literature which has very broad spectrum of research But unfortunately the meaningful related papers are in dearth. In case of each of key words there exist number of papers out of which very few were selected and their notable contribution is presented in the tabulated form in Appendix F.

CHAPTER IV ELEMENTS OF EFFECTIVE PRODUCTION RAMP-UP

4.1 Effectiveness of the Ramp-up and Automobile

Gunther et al. (2005) explained that in today's global, dynamic and competitive environment the introduction of new products is essential for survival of the businesses. Ramp up is considered as the cost driven procedure in the automotive industry where changes in product are inevitable for survival in the market and remain competitive with the peer industrial competitors. However, the new product performance can only be achieved by combining the influence of technical product design and its complexity along with cost drivers in production which as well as influences the potential market price. For these reasons European companies especially have to amplify product customization to stay competitive. Ramp-up specific individualization potentials are mainly generated by the ability to cope with complexity and variety. The short time of changeover from R&D to series production emerges to a strategic chance for real differentiation from competitors due to own product innovations. Lost sales profits due to production problems in the ramp-up phase can never be compensated because of decreased product life cycles. Thus, the proper control of production ramp-ups and advances to an eminent success factor in automotive industry, explains the Gunther et al. (2005).

4.2 Ramp-up Activities

Laurène (2010) has described several of the ramp-up phases but, crux of the issue revolves around translated through the soft and hardwares to enable and produce the desired object. Figure 4.1 shows integration of two system level aspects for the respective purpose full outcome. In this context, the prototyping and learning phase which is, off course, a pre-production phase and is considered the first step where model assembly is manufactured; which is followed by the pilot production or initial run phase.

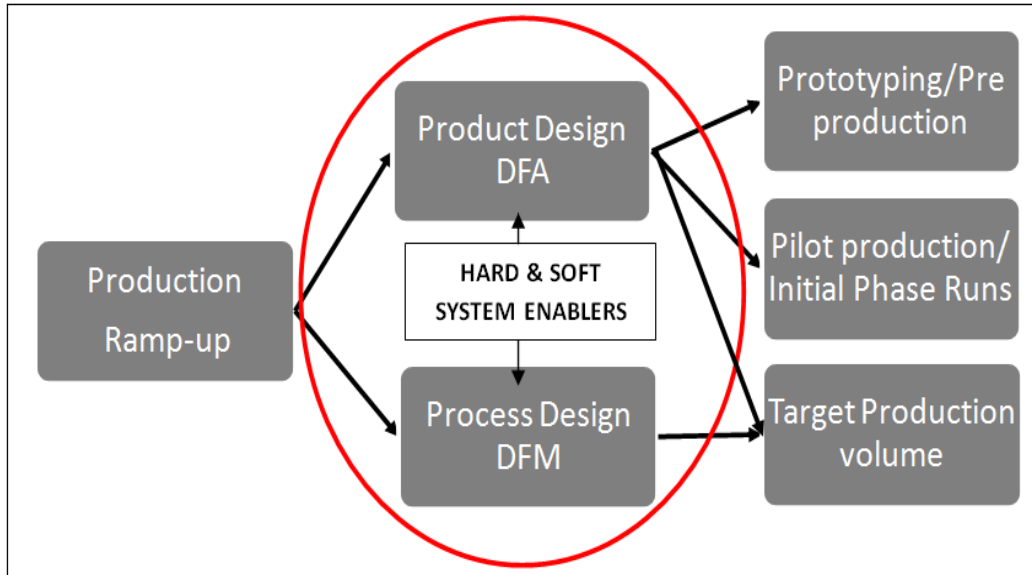

Figure 4.1 Holistic System View of Ramp-up Production

The successful outcome of this entails the measures to make the necessary pace attainable for the target production volume. It is pertinent to note the fact that Reinhart, et al. (2007) points out and I quote that the 90% of the commissioning time is used for delays and activities related to electric and control devices. Again, 70% of this time delay was associated with errors in control software as shown in Figure 4.2. In other words, the correction of defective control software consumes up to 60% of commissioning time or 15% of time-to-delivery.

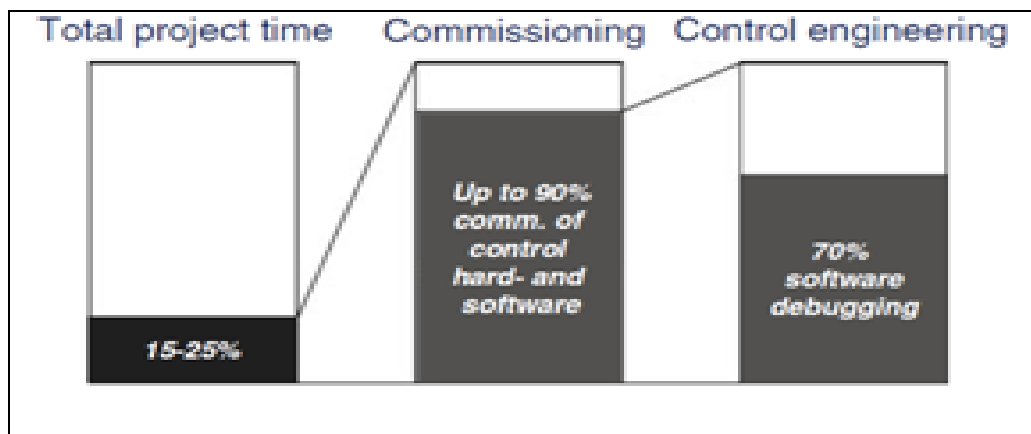

Figure 4.2 Contribution of Control Software Systems (after Reinhart, et al. (2007))

4.3 Elements of Modeling Effective Ramp-up Production

The ramp-up manufacturing concept is being studied by means of drawing system analogy from the basics concept of the famous icam definition of for functional modeling (IDEFo) model as shown in Appendix-B. In this concept formation it has been noticed that if the feedback loop introduced then it will produce further complexity. Therefore, simple analogy from IDEFo model basic's is drawn without imparting its level details and feedback loops just to highlight the core areas of complexity to understanding the primary principles of input, output along with relevant mechanism and control. Simplicity is the essence of system engineering but not the engineering system, where every feedback loop is made by keeping system factual position not the conceptual position as this dissertation took liberty into explaining and to advocate its argument with novelty. In this context, it has been found that the capital and resource investment which is paramount for every project. However, for the business technical and social knowledge data base is essential which requires the capital investment. In order to maintain an effective strategy for the ramp-up, there are important controls likewise cost and quality, reliability and productivity has to be defined productively along with respective purpose. Obviously logical and software mechanism as well as physical and hard mechanism for the purpose of annual yields should be included. Similarly, learning curve with the respective mechanisms of man machine know how is very vital for the success of the system. Next, for the purpose to obtain the stock holders investment, the business have to observe the input of the variation in demands in a respective market segment and for creating a new market segments, niche markets , customization and personalization for creating an innovative new product design (NPD). In this context relevant controlling facts of make to order , capability, customization, quality improvements, functionality tools and plant scalability issues for target production, shorter life cycle of the product are controls which limits the NPD beyond the manufacturing systems mechanism. The product variety and plate form and grouping the parts on families (Group technology principles) and adoption of other new technology and design techniques helps on enhancing the sales and revenue or in other words the blood line of business the cash flow. The manufacturing ramp-up system will require the input of the scalability and functionality in make to order like scenario. But in this context, the most important is the control of maintaining the system

balance, frequency of the capacity addition, means of external and internal capacity control involving the machine tools and plants (hardware) flexibility, supply chain reliability control, quality and productivity control. But, this require logical and soft mechanism, physical and hard mechanism, flexible tools and plants, workers and machinery. Similarly the plant capacity planning will require the input of the work in process, inventory, modularity and variety. But, this needs to have the effective the cost control, inventory control, market fluctuation due to dumping of a product with a low price so that the competitor product is not picked up and becomes out of the market. Beside this, the annual yields for forecasting and supply and demand control are vital planning for the capacity of the plant. No doubt, short term and long term mechanism and intermediate scale platform based products using group technology techniques for the manufacturing process are very vital. Now after the plant capacity planning focuses the system economic order quantity (EOQ) for this the system input is high through put, reliability of supply chain and agility of the system. Next the mechanism of this can be mass customization, mass personalization and capital to provide soft and hard enablers social and technical support mechanism for the market to introduce the product with the new features. While the system has the controls like cost and inventory control, market fluctuation, supply and demand, annual yields for forecasting control etc. Off course, this will bring the turnover on current assets as input to another important system from stake holders point of view and return on investment. The mechanism for this is obviously the revenue be increased and so as the total assets along with the man and machine energy consumption hours etc. Similarly, the cost of goods control, total cost of sales, cost of inventories and account receivables have to be controlled effectively which will deliver the total profit or gain over the stake holders investment. Knowledge base for decision support system requires the input of systematic intelligent planning. But these decisions are always controlled by the technological change, Business activities with other stack holder time and cost control, quality, revenue and sales, supply chain and logistics. However, the possible mechanism could include the skill set mechanism, collaboration mechanism for distributed production, manufacturing and design. Better procurement of tools and plants (hardwares), better know how about the processes involved in business and continuous self learning, self awareness and self adaptation are means to have an

effective mechanism for decision support system. In fact, shorter life cycle of the product, along with customer need satisfaction controls the purpose of the ramp up process enhancing quality with cost control are some of the other important factors avoiding the product recalls and target through required scalable production. The ramp-up process is initiated when errors and mistakes in the design occur and the competitors new product getting pace in the market and it's time to bring the new features in the market otherwise loss of sale could have happen. To overcome this, the functionality of ramp-up is to be devised as mean to achieve goals of organization. In this regard the new product design and process, decentralize production, tier-1 and tier-2 suppliers have to be engaged in such a manner that maximum procurement system functionality have to be achieved. High quality manufacturing, huge outsourcing of parts, material resource planning, enterprise resource planning, product life cycle management, data base repositories new product process plan with product variety are the means to achieve as a mechanism. Besides that effective control of new metrics and respective advanced assessment tools for emission and ecological waste control , shortest product change time, time to create value, time to market for customer and make to order the quantity for market concerned are some of the effective controls. Ramp-up system enablers are the initiators as input like fluctuation of new product development launch, but the lean per unit cost control, reconfigurable process planning, assembly process planning. Logical and soft enablers alongside physical and hard enablers mechanisms will enable to produce the high productivity, with high agility and high quality. Again the ramp up system reconfiguration inputs are the high through put quality and agility which by means of reconfigurability, convertibility, scalability mechanisms and computer aided manufacturing (CAM) and computer integrated manufacturing (CIM) adjustability for reconfigurable machine tools, reconfigurable manufacturing system and reconfigurable assembly methods are the tools for the effective systematic planning. It is worth to mention the fact that the cost per unit control, lead time, cycle time lean waste, reliability, new process plan for equipment utilization facility for the feed stock and off course the reconfigurable process planning and assembly planning are the constraint and control which will enable through enablers to provide systematic effective tools for the systematic planning for management decision support system. In this context related

works of the following authors have been used and some of which are remodeled to explain and highlight the issue in new perspective by describing with use of system dynamics approach of Forrester J.W.(1960) and Sterman (2000) as such notable works of Prenting (1974), Owen (1984), Harrington (1984), Tanner, (1991) , Nof. et al.(1997), Nof (1999), Pang (2004), Boothroyd (2005), Grover (2007), Sule (2008), Koren (2010) and ElMaraghy H.A. et al.(2009) works on Changeable and Reconfigurable manufacturing systems helped to understand and shape this work to transformed and interpreted into different aspect ramp up system dynamics.

4.4 Procurement of Reconfigurable Assembly System

If considered at present set of the equipment generating 2M products/year and has limited capacity growth to accommodate the market demands with rapid response and agility using concurrent engineering strategy then a manufacturing manger finds himself stuck with the capability. Therefore, in order to target to get 6M products/year the manufacturer has to reach its plant with certain procurement amounting to \$200M in investment in reconfigurable assembly system lasting for 10 years approximately with maximum capacity adjustment to the market rapid changing demands. However, this will over shoot the rate of carrying cost as well has been as noted that will rise from less than 100 to 225 dollars per product. This is something challenging which need effective supply chain strategy to create a win-win situation in order to avoid the excessive cost which is possible in this context the model Equation (1) from the list of nomenclature and list of equations provided at the beginning of the dissertation, which is used for transforming the conceptual model.

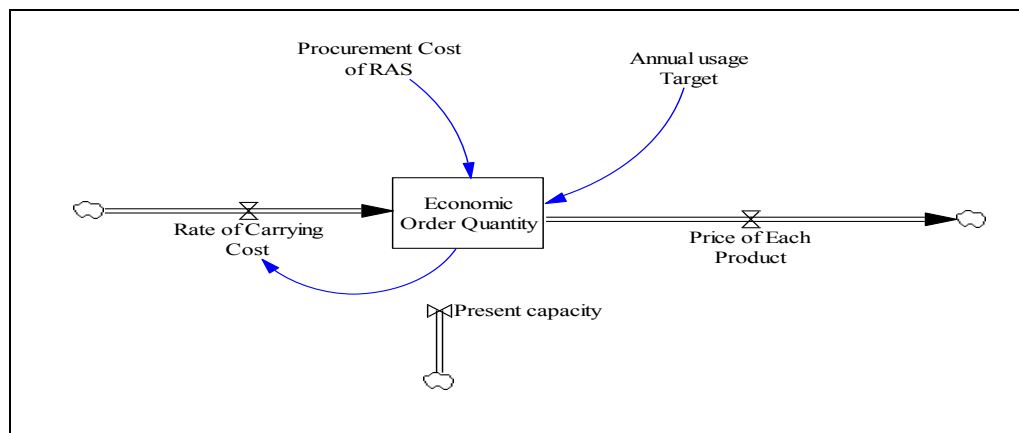

Figure 4.3 Model for Economic Order Quantity.

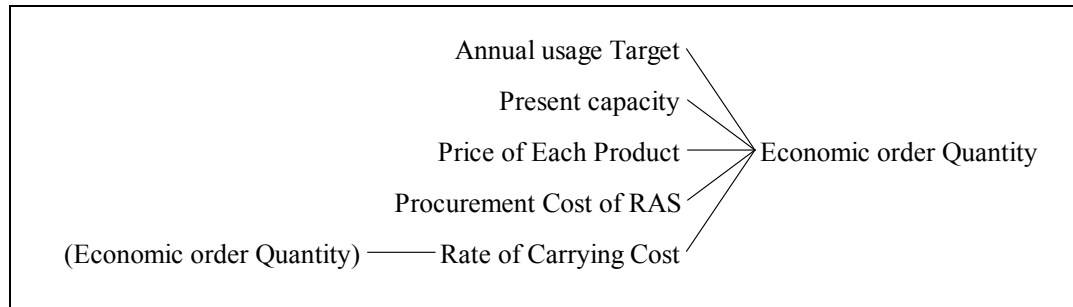

Figure 4.4 Key Relationship for Economic Order Quantity

Case Study # 4.1

The objective of the case study is to model the (EOQ) by using system dynamic technique to study the behavior evolution of the results offered by the static model in this context the system dynamic model is formulated by means of using Vensim DSS version of modeling software. There are other software tools (See Appendix C) which provides system dynamic functionality but Vensim DSS is used in the manufacturing settings mostly and as such the key attribute of the model and important relationship are shown in Figure 4.4 and the model is sketched in Figure 4.3. However, what happens behind the sketch the modeling language codes are shown in Appendix D, changes in programming language as well as respective control can also be made in this mode. This facility is available only in Vensim DSS version. Therefore, now in order to use the simulation we have to model the Equations (1) which is listed in the list of equations at the beginning of this dissertations such that variables are defined and shown in Table 4.1 and the respective parameter's value and definition are shown in Table 4.2.

Table 4.1 Variable Name and Definitions of Case Study # 4.1

Variable name	Variable Definition
Procurement of Assembly	Concept defines the fact how much big system required
Target usage	The customer market segment who will use the product
Economic order quantity	It is the concerned variable which is basic for investigation it is dependable and indirect and related to the fact as to control the inventory as how much quantity order required to be met
Rate of carrying cost	The cost with which the transportation of the product resources and its final product is being carried out.
Present capacity	This is the key variable which describes the current state of the tools and plants to produce the product in question

Consider variable parameters at the initial time the following important elements of model to which following nomenclature is defined accordingly as shown in Table 4.2 such:

Table 4.2 Base Case Variables of Case Study # 4.1

Serial No	Parameter definition and value of Units
1	C_{Pr-RAS} = Procurement cost of reconfigurable assembly =34.8*10E6 with perturbation cost reduced to 200*10E6
2	A_{use-T} = Annual usage target = 2.5million
3	EOQ =Economic order quantity
4	RCC =Rate of carrying cost=0.0036*1/100*EOQ
5	P_{pr} =Price of each product=15.5*10E3
6	P_{Cap} =Present capacity=8.75*10E3

Initial time

$$T_i = 0$$

Final time

$$T_f = 10$$

Units=years

Time Step:

$$dT = 0.125$$

Any instant T:

$$T = \sum_i^n 0.125 \times n + T_i \dots \dots \dots (4.1)$$

Where $n = \frac{T_f - T_i}{\Delta T}$

Therefore the economic order quantity (EOQ) at the final time T_f in terms of products per year can be obtained from the expression given in equation (4.2) below :

$$EOQ(T_f) = \int_{T_i}^{T_f} \{ [(C_{Pr-RAS} \times A_{use-T} \div RCC) \times P_{pr}]^{1/2}, P_{cap} \} * dT + EOQ(T_i) \dots \dots \dots (4.2)$$

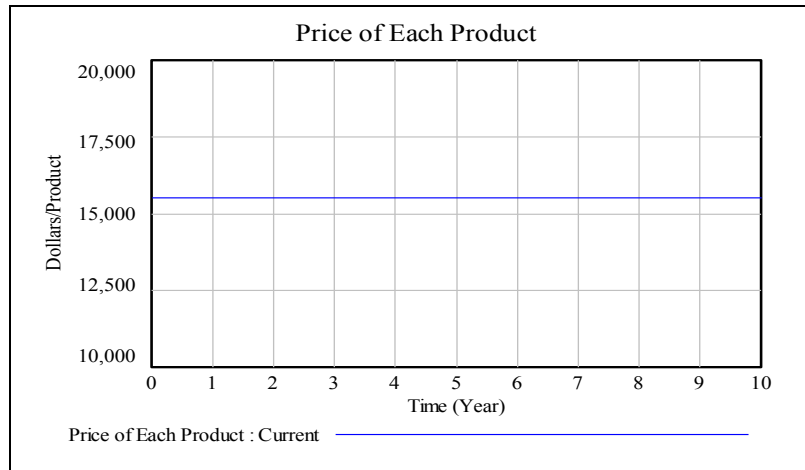

Figure 4.5 Price of Each Product.

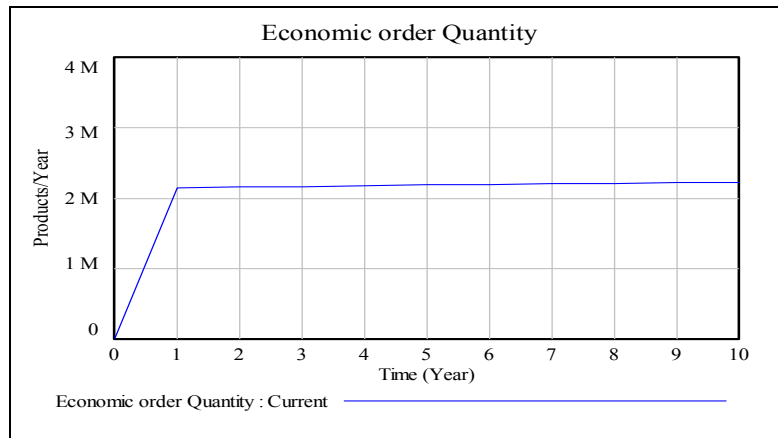

Figure 4.6 The EOQ at Current State

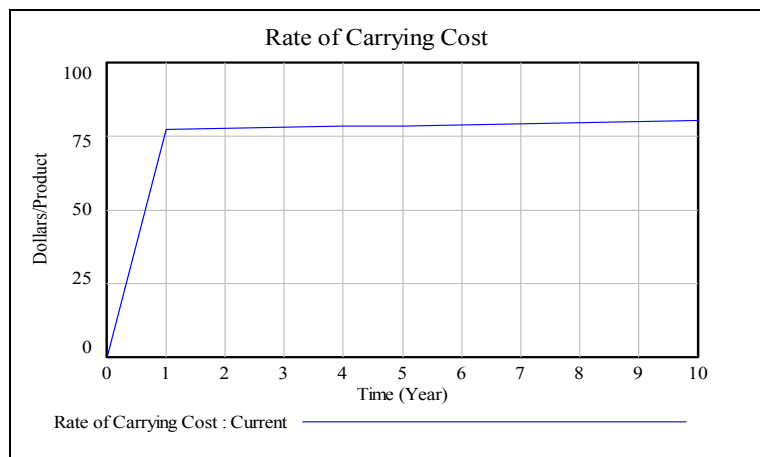

Figure 4.7 Rate of Carrying Cost.

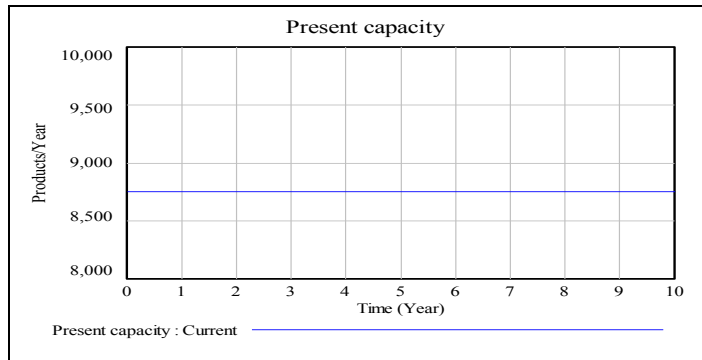

Figure 4.8 The Present Capacity.

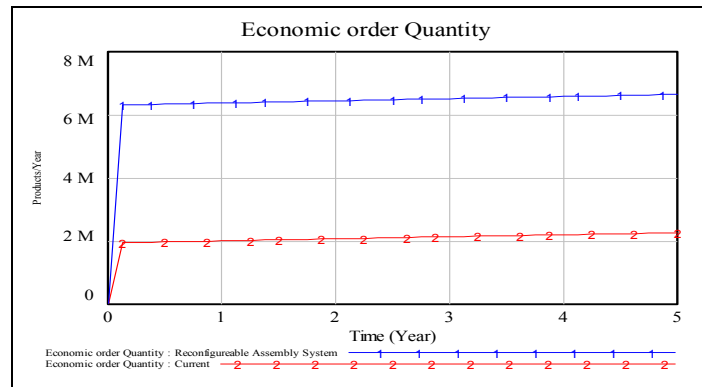

Figure 4.9 EOQ change in Behavior

Figure 4.5 , 4.6 ,4.7 and 4.8 are the base run or current condition of the system behavior display where we assume the price as defined in the parameter definition. We have observed that the system has the consistency in the price tag of the product while the EOQ is maintained. But the EOQ changes as the demand increases. Suppose it is from 2M to 6M what is the support available to extend the capacity or otherwise. In this context, when the system parameters are perturbed to see the behavior then it is observed that the carrying cost of the system which also jumps to a significant amount as shown in the Figure 4.9.

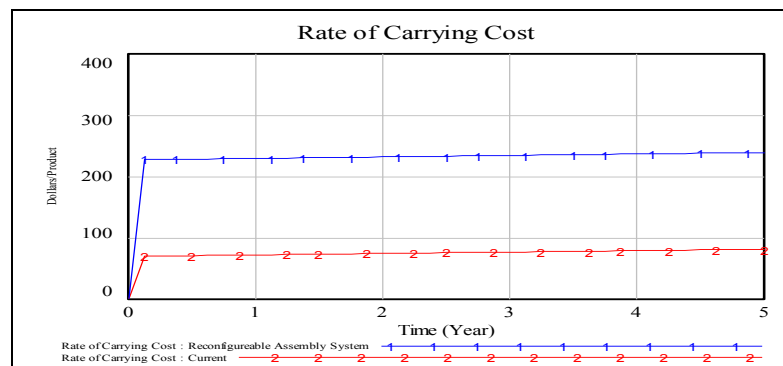

Figure 4.10 Rate of Carrying Cost change

It is understood that it will not be the EOQ fluctuation as shown in Figure 4.10 needs adjustment but also other relevant issues will also be affected for instance the rate of carrying cost aspect of supply chain which shows the behavior pattern in case of the perturbation there off. However, Figure 4.11 shows the multivariate results and Figure 4.12 shows individual traces of the sensitivity which not only validates the model but also reflect the dynamic behavior pattern and their respective perturbation accordingly 75% value in green and 95% value is achievable in blue as shown in Figures 4.11 and 4.12.

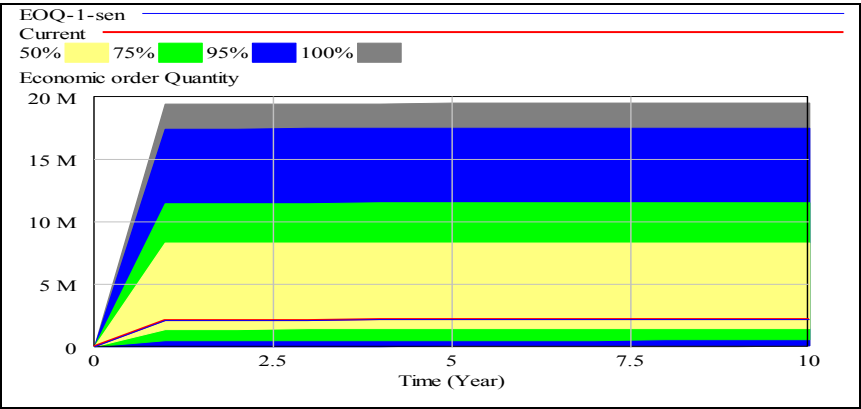

Figure 4.11 Multivariate Simulation Results

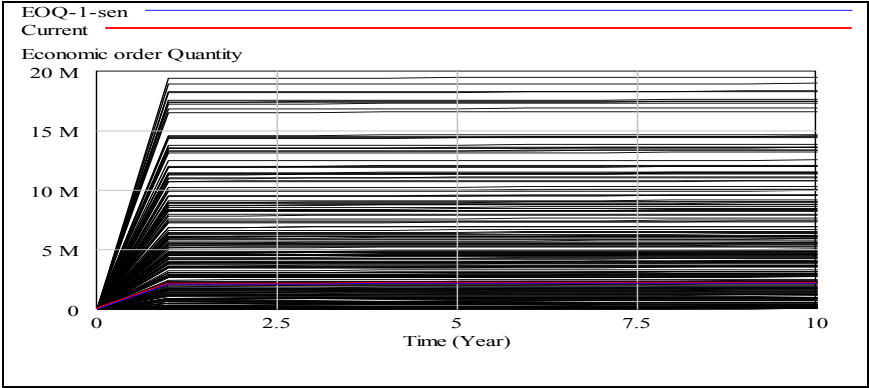

Figure 4.12 Individual Traces Simulation Result

Case Study # 4.2

As we observed that in order to meet the demand, we have to introduce a new model and make necessary adjustment to find out the fact that what will be the best fit for our analysis to provide a decision as such how much are the number of machines will be required to meet the target. In this context, Equation (2) from the list of nomenclature has been used for transforming the conceptual model as such as shown in Figures 4.13 and 4.14.

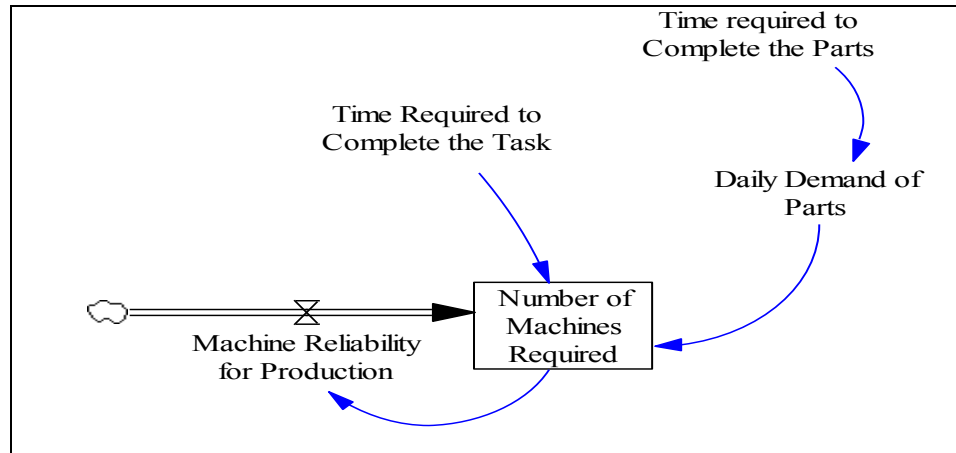

Figure 4.13 Model Number of Machines required for Manufacturing

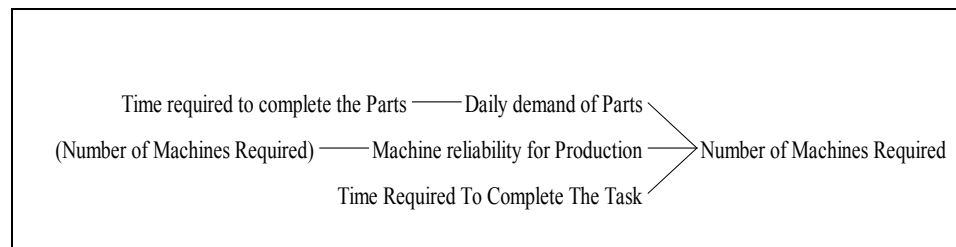

Figure 4.14 Key Relation for Number of Machine Required for Manufacturing

Table 4.3 Variable Definition for Case Study # 4.2

Variable name	Variable Definition
Daily demand of parts	Parts variable required to be produced a slider can increase the quantity to describe the impact
Time required to complete the Task	The task completion is an independent variable perturbation of which describes the impact on the whole system.
Time required to complete the parts	This is the variable which describes the completion of the entire operation on a job blank.
Machine reliability for production	This variable describes the fact that how much is machine reliability is assured before a break down occur.
Daily demand of the parts	This is the variable key variable which describes the current state of the tools and plants to produce the product in question

Let us consider for the model the fact that firstly take the variable definition from the above Table 4.3 and then model formulates as follow

Initial time

$$T_i = 0$$

Final time

$$T_f = 100$$

Units=Weeks

Time Step:

$$dT = 0.5$$

Any instant T:

$$T = \sum_i^n 0.5 \times n + T_i \dots \dots \dots (4.3)$$

Where $n = \frac{T_f - T_i}{\Delta T}$

Consider that at the initial time the following important elements of the model according to which following nomenclature is used for parameters and their respective definition and the value of the variable as defined for the base case as shown in Table 4.4 and Equation 4.3

Table 4.4 Base Case Variables of Case study # 4.2

Serial No	Parameter definition and value
1	Daily demand of parts= $D_{D-PARTS} = 500$ with the initial time T_i and given units of parts.
2	Time required to complete the task= $T_{COMP-TASK} = 10$ with the initial time T_i and given units of Sec.
3	Time required to complete the Parts= $T_{COMP-PART} = 12$, with the initial time T_i and given units of parts,
4	Machine reliability for production= $REL_{M/C-PROD} = 1$, with the initial time T_i and given units of m/c.
5	Number of machines required= $No_{-M/C-REQ}$ with the initial time T_i and given units of m/c
6	(Daily demand of parts) $D_{D-PARTS} = 500 /$ (Time required to complete the Parts) $T_{COMP-PART}$, $D_{D-PARTS} = 500 / T_{COMP-PART}$
7	(Machine reliability for production) $REL_{M/C-PROD} = 1 * ($ Number of machines required) $No_{-M/C-REQ}$

Following expression gives us the relation at the final time for number of machine required as shown in equation (4.3)

$$No_{-M/C-REQ}(T_f) = \int_{T_i}^{T_f} [(DD - PARTS) \times 1 / REL_{M/C-PROD} \times 1 / T_{COMP-TASK}] \times dT + No_{-M/C-REQ}(T_i) \dots \dots \dots (4.3)$$

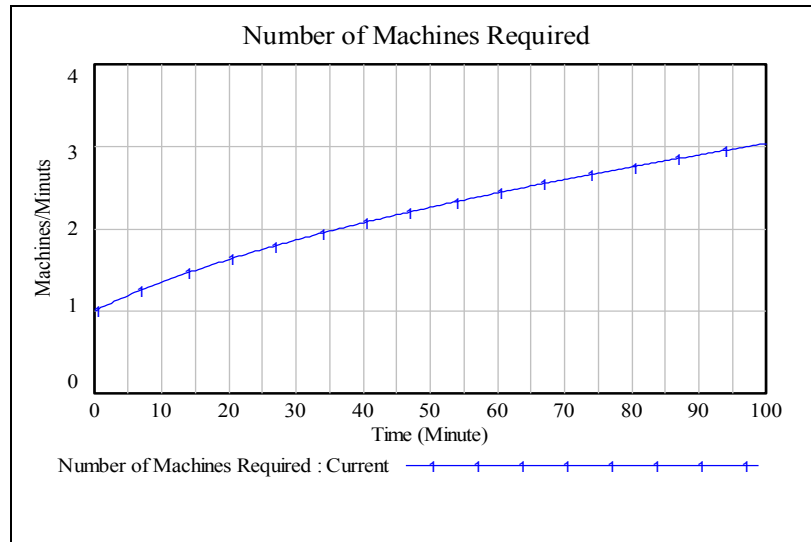

Figure 4.15 Numbers of Machines for Similar Part Family.

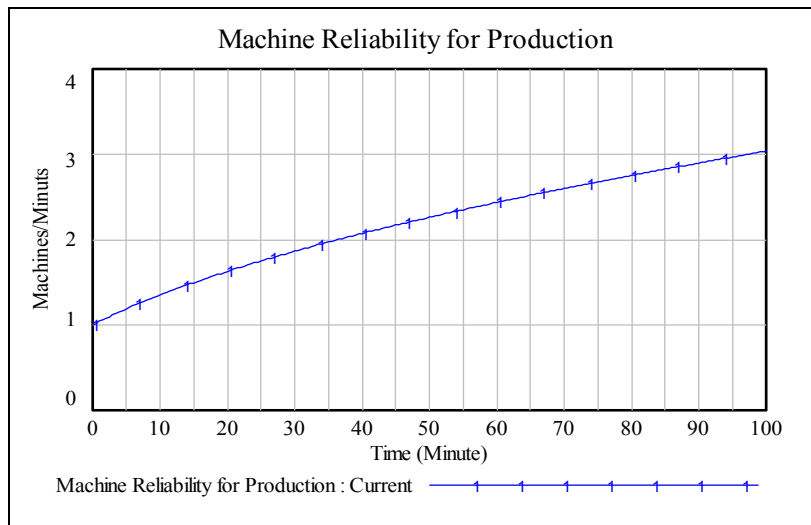

Figure 4.16 Reliability of the Machines.

From Figures 4.15 and 4.16 it is clear that for similar part family if more machinery is required then in that case the same must be reliable in order to achieve the goals. Similarly Figures 4.17 and 4.18 shows the multivariate and individual traces of the simulation models. This does not only validate our model by showing us the same pattern but also suggest big picture for our extended understanding. Next, In this regard as such provided that current parameters if kept intact then 50 % , 75 % and 95 % numbers of machines will be required as shown in Figures 4.17 and 4.18.

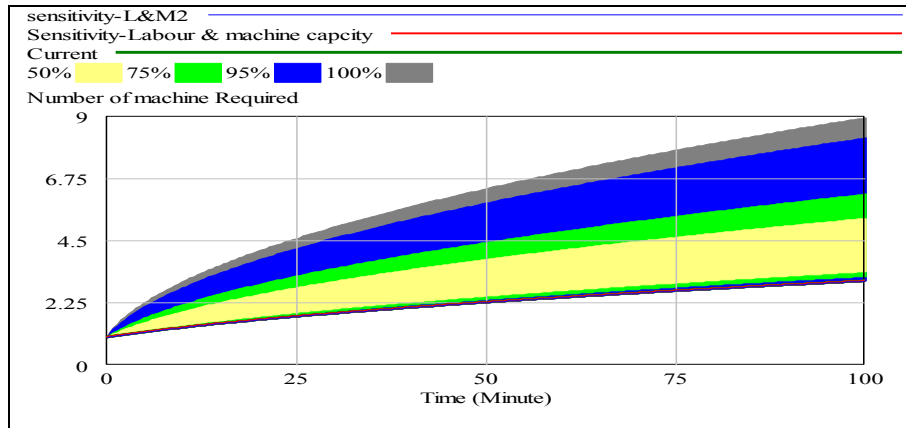

Figure 4.17 Results of Multivariate Simulation.

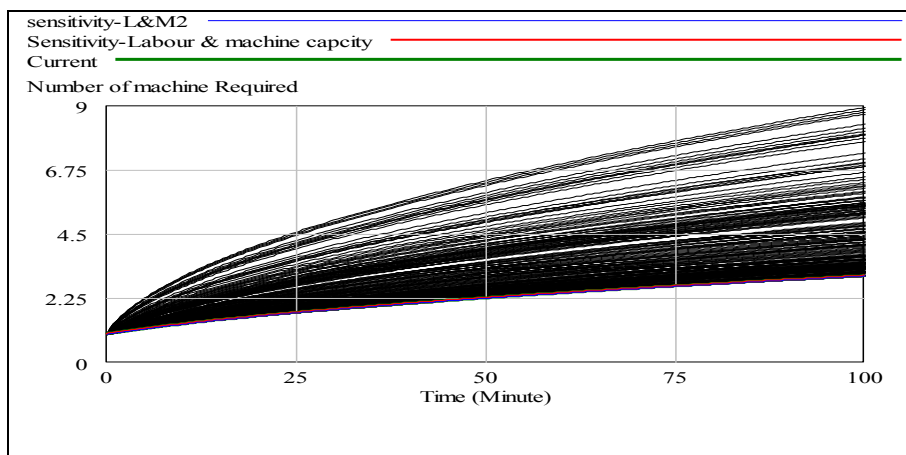

Figure 4.18 Results of Individual Traces Sensitivity

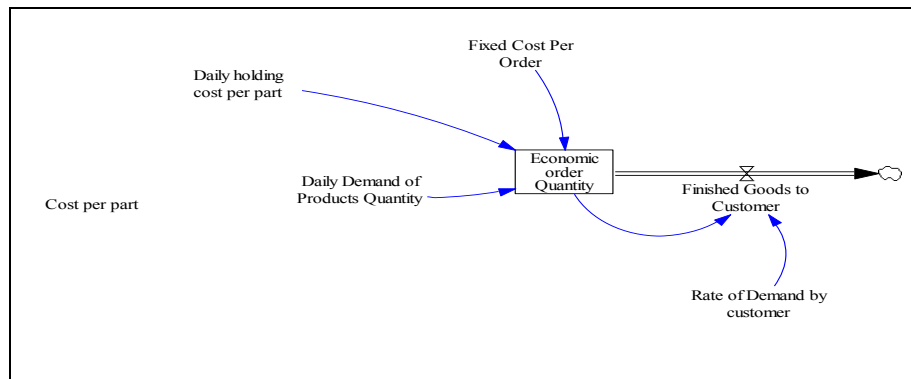

Figure 4.19 Modeling Dynamics of the Finished Goods to Customer

Case Study # 4.3

Before going any further for analysis we go back to our previous model of case study 4.1 and make few adjustment and try to understand the behavior pattern of the with the dynamics of finished goods reaching to the customer in this context new model as shown in Figure 4.19. The model has been developed to consider the modeling Equations (1 and

3) whose variable definitions are given in Table 4.5 and respective parameters defined with their units values in Table 4.6.

Initial time

$$T_i = 0$$

Final time

$$T_f = 54$$

Units=Weeks

Time Step:

$$\Delta T = 0.125$$

Any instant T:

$$T = \sum_i^n 0.125 \times n + T_i \dots \dots \dots (4.4)$$

Where $n = \frac{T_f - T_i}{\Delta T}$

Table No 4.5 Variable Names and Definition for Case Study # 4.3

Variable name	Variable Definition
Carrying cost	The cost with which the transportation of the product resources and its final product is being carried out.
Daily holding cost	This is the variable which is very important and is the core to understand the lean manufacturing concept as of the just in time. If the inventory of the raw material or finished product is increased before the shipment or during production task delay due to break down of T& P, etc. that could causes extra burden on the total cost.
Cost per part	This is the cost which is necessarily if the cost assumed to be incurred on the part but variation of this produces adverse affects as well.
Economic order quantity	It is the concerned variable which is basic for investigation. It is dependable and indirect and related to the fact as to control the inventory as how much quantity order required to be meet
Daily demand of product quantity	This is the variable (key variable) which describes the current state of the tools and plants to produce the product in question

Table 4.6 Base Case Variables of Case Study # 4.3

Serial No	Parameter definition & Value
1	F_{CO_i} =Initial fixed cost per order
2	CC =Carrying cost =\$200

3	$DDP = \text{Daily demand of the products quantity} = 100 \times 1/7$
4	$DHC = \text{Daily holding cost} = 4$
5	$C_{part} = \text{Cost l / part} = 5$
6	$R_{EOQ} = \text{Rate of demand by customer for } EOQ = 100 \text{ products}$
7	$EOQ = \text{Economic order quantity}$
8	$F_{GCus} = \text{Finish goods to customer}$

Therefore the economic order quantity (EOQ) at the final time T_f we can have in terms of given units of products quantity per week we have the relation as shown in Equation (4.5) as such :

$$EOQ(T_f) = \int_{T_i}^{T_f} [(F_{COi} \times R_{DCus}) \times (1 / DHC)^{1/2} \times C_{part} - F_{GCus}] * dt + EOQ(T_i) \dots \dots \dots (4.5)$$

Similarly, rate of demand by the customer can be given from the expression in units of products/week R_{EOQ} and Rate of demand by customer for $EOQ = 1 * DDP = \text{Daily demand of the products quantity}$.

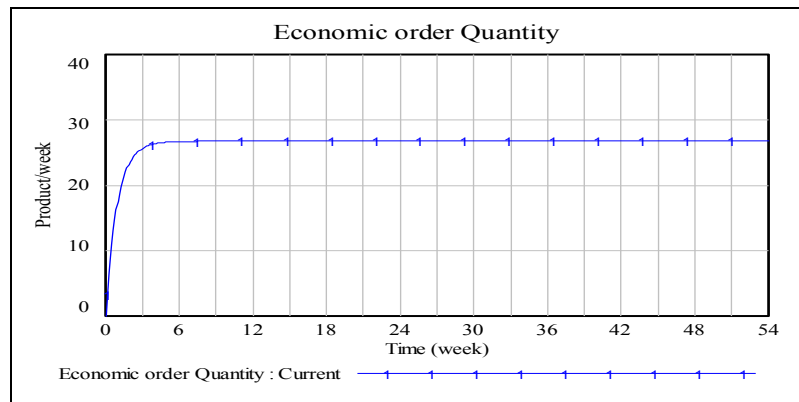

Figure 4.20 Presents Capacity.

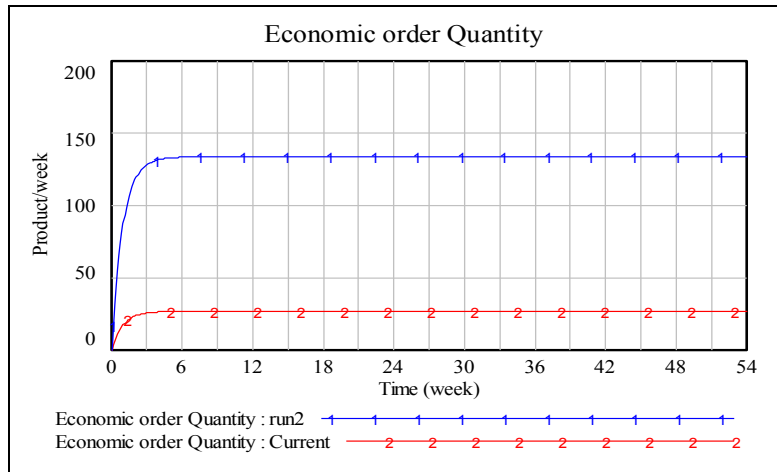

Figure 4.21 EOQ Estimate.

It is found that the present capacity can dispatch the finished goods to the customer with maximum perturbation in EOQ to a level of about 150 products per week as shown in Figures 4.20 and 4.21 above. There is no significance change in EOQ and so Figure 4.22 shows that the same amount of finished goods to customer will be available because



Figure 4.22 Finished Goods Pattern to the Customer

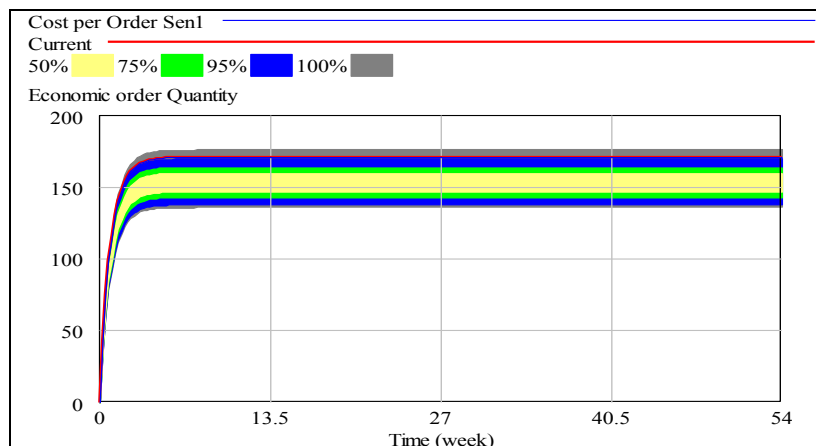

Figure 4.23 Multivariate Simulation Result

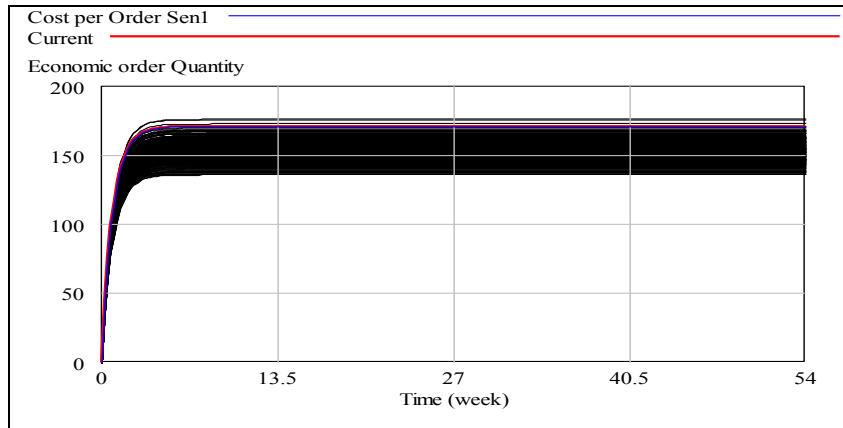

Figure 4.24 Individual Traces of Multivariate Sensitivity.

the capacity and capability limitation for which we need to put real efforts enhancing the production capacity. Similarly, Figures 4.23 and 4.24 show the sensitivity analysis results of model by validating the model as such the behavior pattern appears in multivariate and their individual traces are the same. At this juncture we do final analysis for total cost for attaining a certain level of the EOQ and for this purpose we use the following model whose important relations are shown in Figures 4.25 and 4.26 as such bases for Case Study # 4.4:

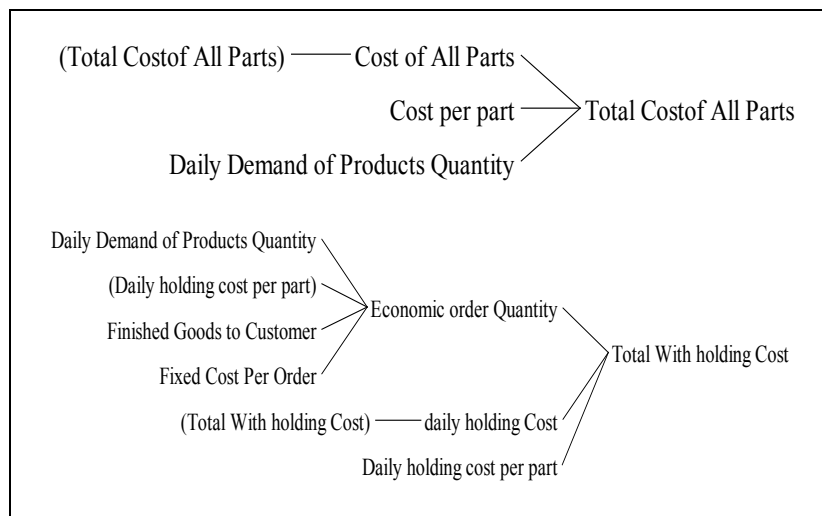

Figure 4.25 Key Relations of the Model

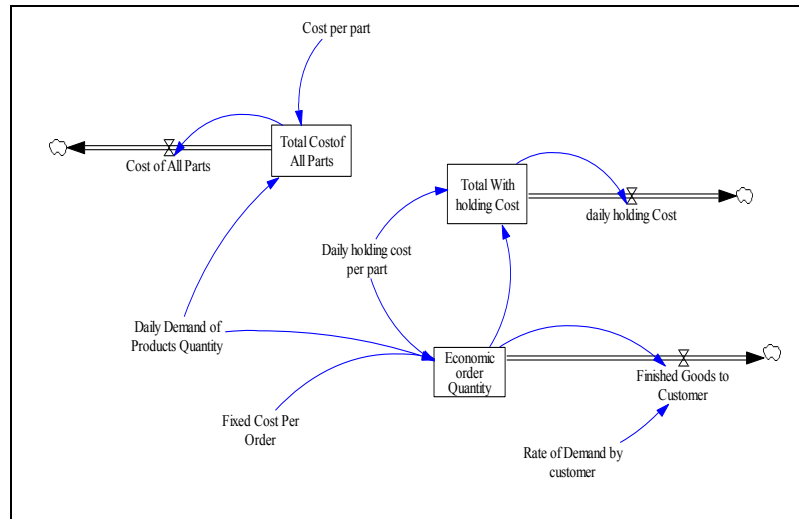

Figure 4.26 Modeling Integrated Aspect for Meeting the Target

Case Study # 4.4

Now this brings us again to the situation where as we have to re-model the problem incorporating a different aspect by re-defining the variables and making total cost of all parts, EOQ and total with holding cost for increase in production volume entails the inventory issues which are very important to be analyzed as such shown in the Figure 4.25 with key relations in the context. Now, we are sketching the model as shown in Figure 4.26 for the simulation results.

Initial time

$$T_i = 0$$

Final time

$$T_f = 54$$

Units of time= Week

Time Step:

$$dt = 0.25$$

Any instant T:

$$T = \sum_i^n 0.25 \times n + T_i \dots \dots \dots (4.6)$$

Where $n = \frac{T_f - T_i}{\Delta T}$

In this context the variable definition and the nomenclature used in this case study is shown in Table 4.7 and parameter's definition and respective values are shown in Table 4.8.

Table 4.7 Variable Name and Definition for Case Study # 4.4

Variable Name	Variable Definition
Cost per parts	Cost of the parts is a variable which fluctuate according to the cost of the processes and labour machine hours involved there in.
Daily demand of product quantity	This variable defines the perturbation of the demand if occurred what effect will be the outcome on the system
Fixed cost per order	This is also a variable the cost of which is usually fluctuates with other influencing variables.
Total cost of all parts	It is the major variable which is dependable on the variation of other variables its projection results in the total system behaviour change.
Daily demand of product quantity	The fluctuation of this variable effects the associated other variable values demand changes, capacity and labour machine requirement utilization that affects the system.
Daily with holding cost	This is the variable which is very important and is the core to understand the lean manufacturing concept as of the just in time. If the inventory of the raw material or finished product is increased before the shipment or during production task delay due to break down of T & P etc causes extra burden on the total cost if this is perturbed.

Table 4.8 Base Case Variables for Case Study # 4.4

Serial No	Parameter definition and unit value
1	<i>Cost per part=CP-parts =5 , with units of dollar/product</i>
2	<i>Daily demand of products quantity= $D_{D-PrQ} = 100$, with units of product/week</i>
3	<i>Daily holding cost per part=$C_{DW-holding} = 4$, with units of dollars/week</i>
4	<i>Fixed cost per order= $C_{fixed-Or} = 200$, with units of product /week</i>
5	<i>Rate of demand by customer=$R_{D-Cus} = 100$ with the units of products/week</i>
6	<i>Total cost of all parts=$C_{T-parts}$</i>
7	<i>Cost of all parts= $C_{A-parts}$</i>
8	<i>Daily demand of products quantity= D_{D-PrQ}</i>
9	<i>Fixed cost per order= $C_{fixed-Or}$</i>

10	<i>Total with holding cost</i> = $CT_{W-Holding}$
11	<i>Economic order quantity</i> = EOQ
12	<i>Finished goods to customer</i> = Gf_{-Cus}
13	<i>Rate of demand by customer</i> = R_{D-Cus}

Similarly at the initial time given units known values are as shown in Table 4.8 above , Next, it is important that at the initial time we have following relations as well with their respective units products /week.

(Shipping daily cost) $C_{D-Shipping}$ = (Total shipping cost) $CT_{shipping}$ (rate of daily Shipping cost) $R-C_{D-Shipping}$

$$C_{D-Shipping} = CT_{shipping} \times R-C_{D-Shipping}$$

(Finished goods to customer) $G_{finish-Cus}$ = (Rate of demand by customer) R_{D-Cus} – (Economic order quantity) EOQ

$$G_{finish-Cus} = R_{D-Cus} - EOQ$$

Now, the total cost of all parts at the final time T_f and the units of dollars/week are estimated by Equation (4.7).

$$C_{A-parts}(T_f) = \int_{T_i}^{T_f} [(C_p - parts + D_D - Pr Q) - C_T - parts]dT + C_{A-parts}(T_i).....(4.7)$$

Similarly total with holding cost at the final time T_f with the unit cost of dollars/week is estimated by Equation (4.8).

$$C_{TW - holding}(T_f) = \int_{T_i}^{T_f} [(C_{DW - Holding} + EOQ) \times 1/2 - C_{DW - Holding}]dT + C_{TW - holding}(T_i).....(4.8)$$

Now finally the Economic Order Quantity(EOQ) can be calculated by Equation (4.9) as such that at the final time T_f and the units of products / week is

$$EOQ(T_f) = \int_{T_i}^{T_f} [(C_{fixed - or} \times D_D - Pr Q) \times (1/ C_{DW - Holding})^{1/2} + G_{finish - Cus}]dT + EOQ(T_i).....(4.9)$$

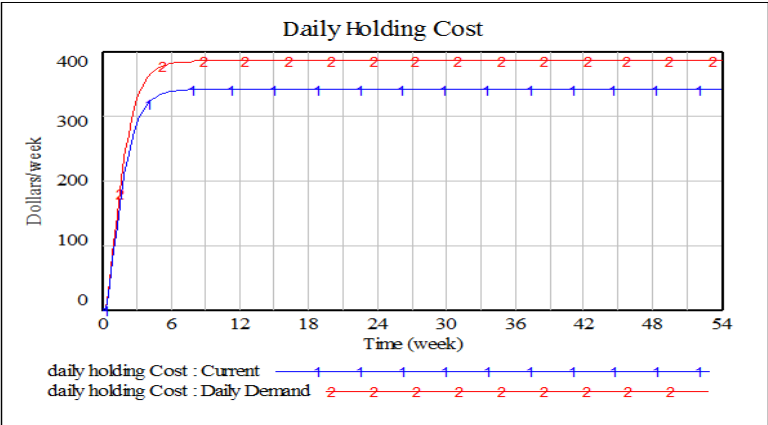

Figure 4.27 Daily with Holding Cost.

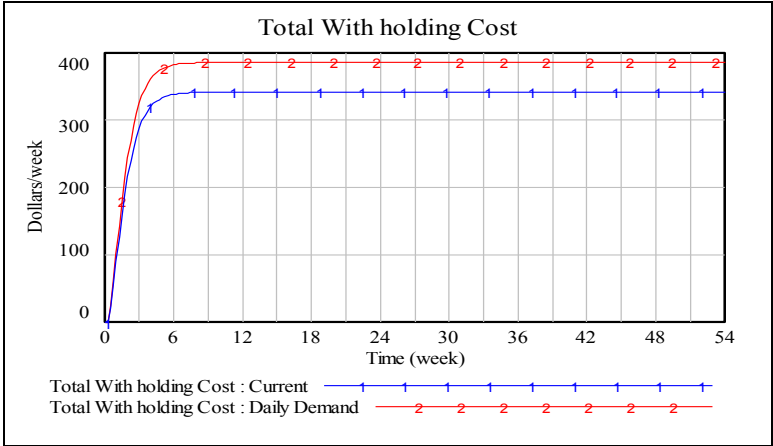

Figure 4.28 Total with Holding Cost

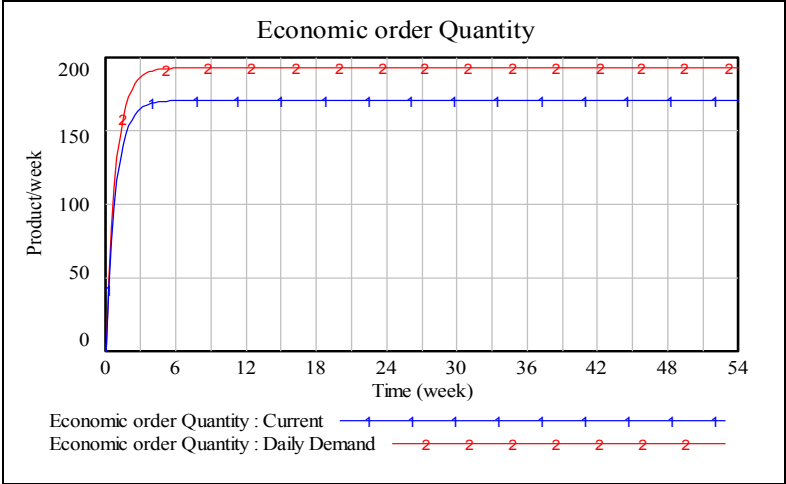

Figure 4.29 Economic Order Quantity.

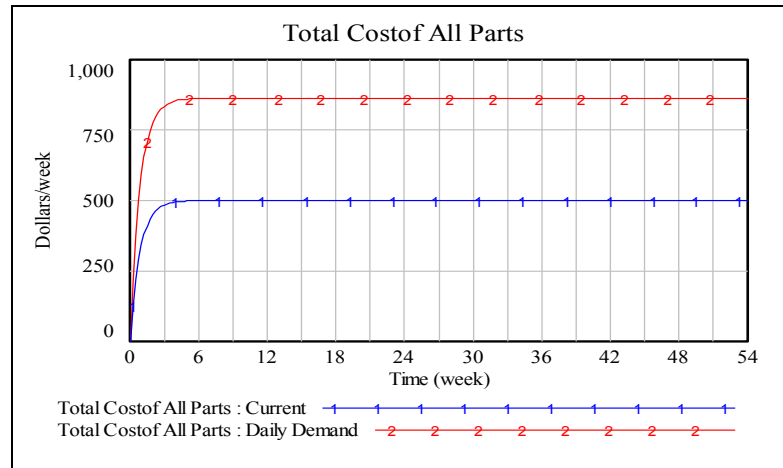

Figure 4.30 Total Cost of All Parts.

The results of the modeling reveals that (from Figure 4.27 and 4.28) that daily demands will remain stable till a big change occur which we have checked by perturbing the behavior but this results are in same behavior pattern without bringing any significance except in magnitude, which also depicts the withholding cost of goods to be stable provided that EOQ involved is also remain in a stable state as demonstrated in Figures 4.29 and 4.30. Whereas the EOQ is perturbed from its current state to the desired increase in daily demands which resulted in higher products to be produced per week. Therefore this reflects the next figure where as the surge in the daily demands of the parts will increase the cost of the parts in terms of dollars spend per week.

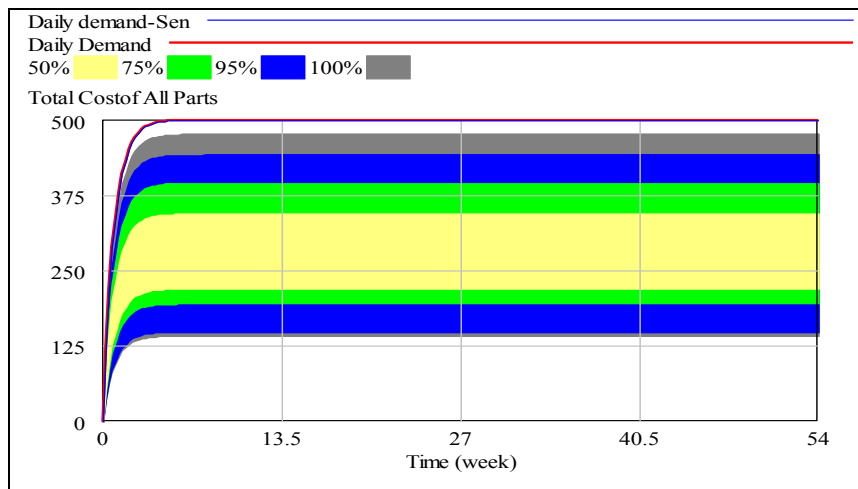

Figure 4.31 Total Cost of all Parts Multivariate Simulation

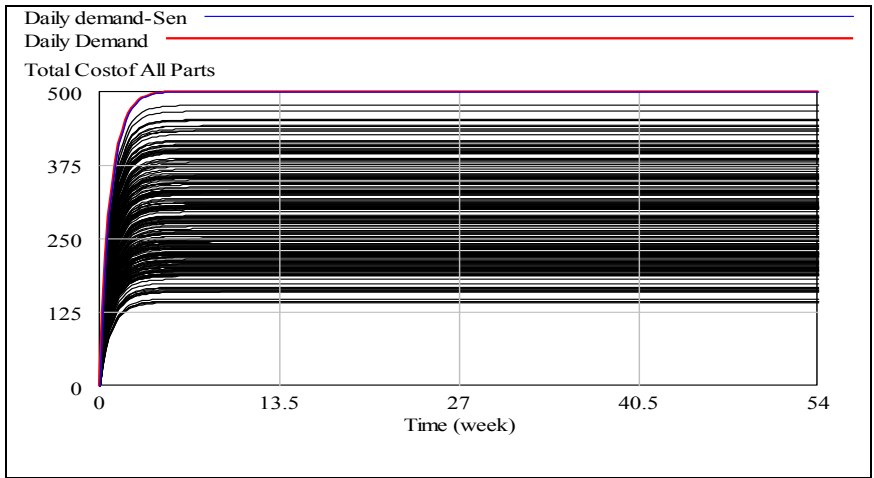

Figure 4.32 Total Cost of All Parts Individual Traces

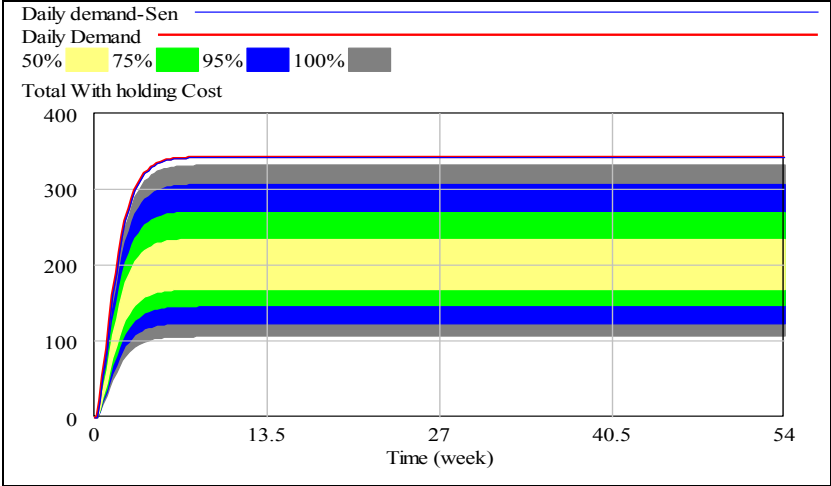

Figure 4.33 Total with Holding Cost Multivariate Result

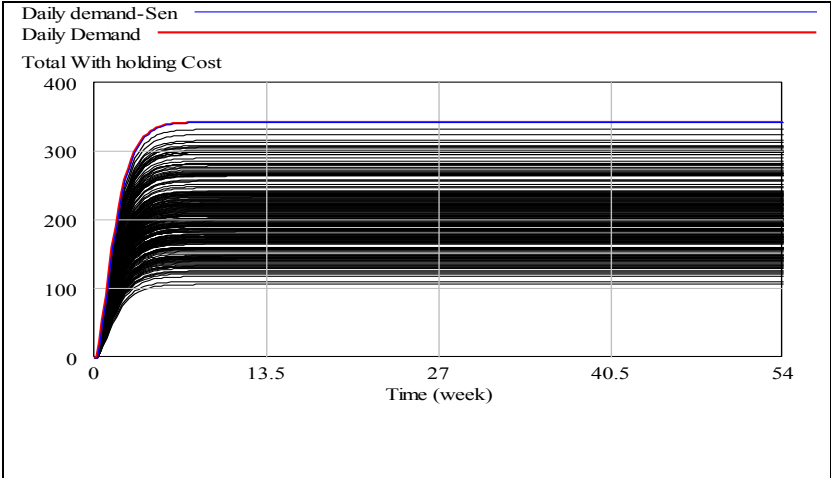

Figure 4.34 Total with Holding Cost Individual Traces

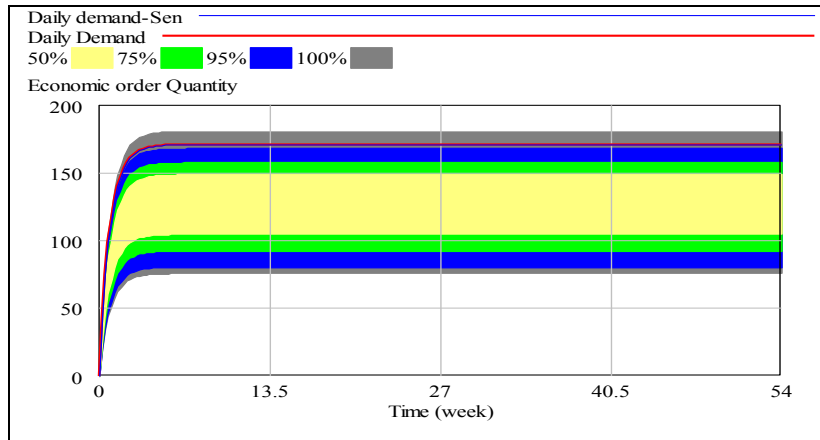

Figure 4.35 EOQ Multivariate Sensitivity .

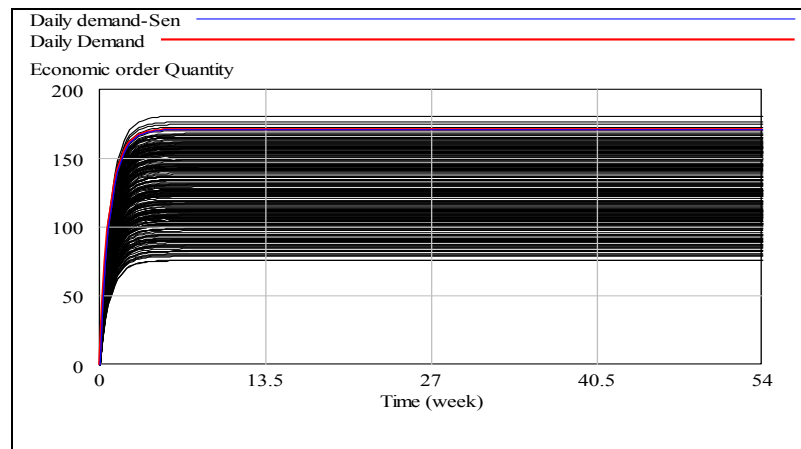

Figure 4.36 EOQ Individual Traces of Sensitivity

However, the total amount jumps from one stable level to the next higher stable level of magnitude as per daily increase in demand in focused as shown in Figure 4.29. Now from Figures 4.30,4.31,4.32,4.33,4.34,4.35 and 4.36 show the sensitivity of multivariate and individual traces which not only validates the model but also provides us the big picture of the system as well. The distribution projects and the curve indicates that in about 0-3 weeks the saturation occurs and there is no more further increase except it becomes stable, provided for the variable parameter remains within same random limit which was intrinsic to the system. The multivariate Monte Carlo simulation run suggest that for the given random variables the system behavior is the same which validates the model and alongside depicts the fact that lower bound and upper bound random variables projects the distribution in early couple of week or so, say 5 days where as the 75% to 95% variation can occur accordingly in nearly all level variables resulting in goal seek behavior showing negative exponential growth.

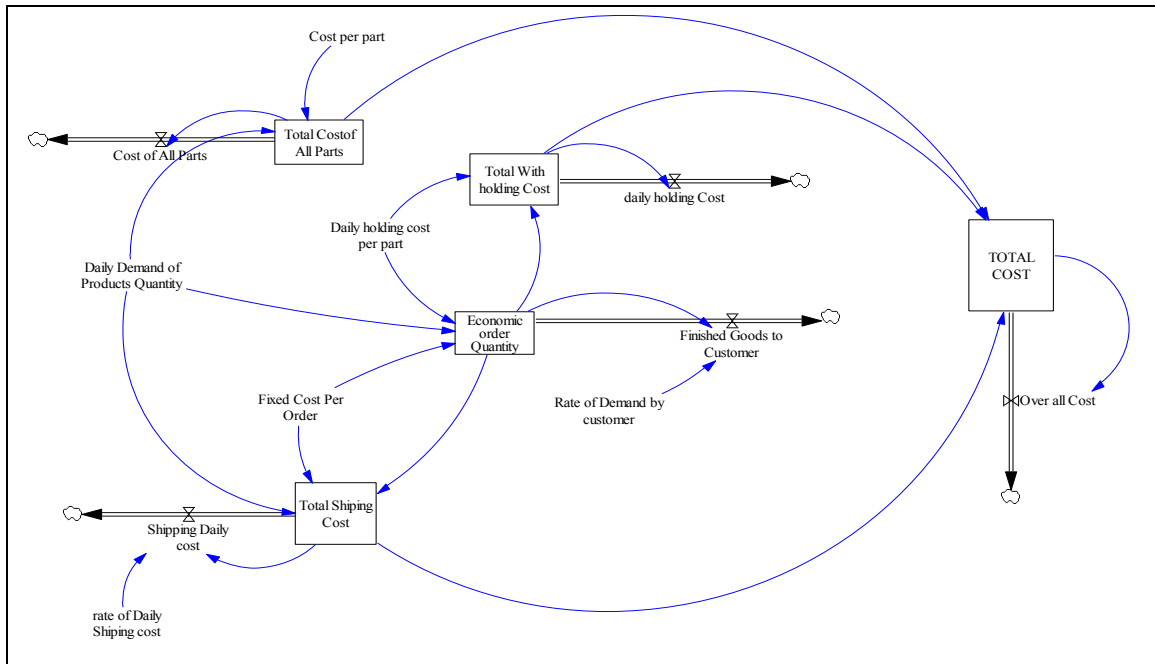

Figure 4.37 Modeling Integrated with Shipping and Overall Cost

Case Study # 4.5

This scenario compels us to model the problem as shown in Figure 4.37 in a way that it should also encompasses the total shipping behavior which in turn will give a big picture while we model the rate of overall cost. So for this purpose to remodel the following equations (1) to (4) in the list of equations in the beginning to make the simulation run for the results for our base case with the variables as define in Table 4.9 besides the parameters are defined and their respective values are shown in Table 4.10. In this context remodeling has been made to study the integrated dynamic effects of the system as such :

Initial time

$$T_i = 0$$

Final time

$$T_f = 54 \text{ Seconds}$$

Time Step:

$$dt = 0.25$$

Any instant T:

$$T = \sum_i^n 0.25 \times n + T_i \dots\dots\dots (4.10)$$

Where $n = \frac{T_f - T_i}{\Delta T}$

Table 4.9 Variable Names and Definitions for Case Study # 4.5

Variable Name	Variable definition
Overall cost	This is the system main variable which shows the behaviour of the system as a whole in terms of cost. It is a dependable variable as this depends upon other integrated variables which are associated as a cost factor to the system concern.
Cost per parts	Cost of the parts is a variable which fluctuate according to the cost of the processes and labour machine hours involved there in.
Daily demand of product quantity	This variable defines the perturbation of the demand if occurred what effect will be outcome of the system
Fixed cost per order	This is also a variable the cost of which is usually fluctuates with other influencing variables.
Total cost of all parts	It is the major variable which is dependable on the variation of other variables its projection results in the total system behaviour change.
Daily demand of product quantity	The fluctuation of this variable effects the associated other variable values demand changes, capacity and labour machine requirement utilization affects the system.
Total with holding cost	This is the variable which is very important and is the core to understand the lean manufacturing concept as of the just in time. If the inventory of the raw material or finished product is increased before the shipmen or during production task delay due to break down of hardware etc causes extra burden on the total cost if this is perturbed.
Total shipping cost	The shipping cost includes the transportation of the finished goods.

Table 4.10 Base Case Variables for Case Study # 4.5

Serial No	Parameter definition and Unit value
1	<i>Total cost of all parts</i> = $C_{T-parts}$
2	<i>Total shipping cost</i> = $CT_{shipping}$
3	<i>Total with holding cost</i> = $CT_{W-Holding}$
4	<i>Overall cost</i> = $C_{overall}$
5	<i>Rate of daily shipping cost</i> = $R-C_{D-Shipping}$
6	<i>Fixed cost per order</i> = $C_{fixed-Or}$
7	<i>Daily demand of products quantity</i> = D_{D-PrQ}
8	<i>Economic order quantity</i> = EOQ

9	<i>Shipping daily cost</i> = $C_{D-Shipping}$
10	<i>Daily holding cost</i> = $C_{DW-holding}$
11	<i>Cost per part</i> = $CP-parts$
12	<i>Cost of all parts</i> = $C_{A-parts}$
13	<i>Overall cost</i> = CO
14	<i>Total cost</i> = C_{Total}
15	<i>Daily holding cost per part</i> = $C_{DW-holding}$
16	<i>Rate of demand by customer</i> = R_{D-Cus}
17	<i>Finished goods to customer</i> = $Gf-Cus$
18	<i>Rate of daily shipping cost</i> = $R-C_{D-Shipping} = 1$, with units of dollars/week
19	<i>Cost per part</i> = $CP-parts = 5$, with units of dollar/product.
20	<i>Daily demand of products quantity</i> = $D_{D-PrQ} = 100 * 1/7$, with units of product/week
21	<i>Daily holding cost per part</i> = $C_{DW-holding} = 4$, with units of dollars/week
22	<i>Fixed cost per order</i> = $C_{fixed-Or} = 200$, with units of product /week
23	<i>Rate of demand by customer</i> = $R_{D-Cus} = 100$, with the units of products/week

Now let us consider that at the initial time with their respective units as such mentioned with their parameter value in Table 4.10 Similarly at the initial time following are the relations as such explained below

(Cost of All Parts) $C_{A-parts} =$ (Total Cost of All Parts) $C_{T-parts}$, with given units of dollars/ products

$$C_{A-parts} = C_{T-parts}$$

Similarly, (Daily holding cost per part) $C_{DW-holding} =$ (Total with holding Cost) $CT_{W-Holding}$ with units of Dollars /week

$$C_{DW-holding} = CT_{W-Holding}$$

Also (Overall Cost) $C_{\text{overall}} = (\text{Total Cost}) C_{\text{Total}}$ with units of dollars /week

$$C_{\text{overall}} = C_{\text{Total}}$$

Next it is important that at the initial time we have the following relations as well with their respective units products /week

(Shipping daily cost) $C_{D\text{-Shipping}} = (\text{Total shipping Cost}) CT_{\text{shipping}}$ (Rate of daily shipping cost) $R\text{-}C_{D\text{-Shipping}}$

$$C_{D\text{-Shipping}} = CT_{\text{shipping}} \times R\text{-}C_{D\text{-Shipping}}$$

(Finished goods to customer) $Gf_{\text{-Cus}} = (\text{Rate of demand by customer}) R_{D\text{-Cus}} - (\text{Economic order quantity}) \text{EOQ}$

$$Gf_{\text{-Cus}} = R_{D\text{-Cus}} - \text{EOQ}$$

Now for calculating the values for the final time T_f we have the respective units of dollars/week as expressed in Equations (4.11,4.12,4.13 and 4.14)

$$CT(T_f) = \int_{T_i}^{T_f} [(CT_{\text{parts}} + CT_{\text{shipping}} + CT_{\text{w-holding}}) - C_{\text{overall}}]dT + CT(T_i) \dots \dots \dots (4.11)$$

$$C_{A\text{-parts}}(T_f) = \int_{T_i}^{T_f} [(C_{p\text{-parts}} + DD - Pr Q) - C_{T\text{-parts}}]dT + C_{A\text{-parts}}(T_i) \dots \dots \dots (4.12)$$

$$CT_{\text{shipping}}(T_f) = \int_{T_i}^{T_f} [(C_{p\text{-parts}} + DD - Pr Q) \times \text{EOQ} - C_{D\text{-Shipping}}]dT + CT_{\text{shipping}}(T_i) \dots \dots \dots (4.13)$$

$$C_{TW\text{-holding}}(T_f) = \int_{T_i}^{T_f} [(C_{DW\text{-Holding}} + \text{EOQ}) \times 1/2 - C_{DW\text{-Holding}}]dT + C_{TW\text{-holding}}(T_i) \dots \dots \dots (4.14)$$

Now finally the economic order quantity (EOQ) can be calculated from the Equation (4.15) as such that at the final time T_f and the units of products /week.

$$EOQ(T_f) = \int_{T_i}^{T_f} [(C_{\text{fixed-or}} + DD - Pr Q) \times C_{DW\text{-Holding}}^{1/2} + G_{\text{finish-Cus}}]dT + EOQ(T_i) \dots \dots \dots (4.15)$$

If the daily demand is increased from 100 products to the 400 products then for this purpose the perturbation will give us the following results shown on Figures (4.38) and (4.39) as such:

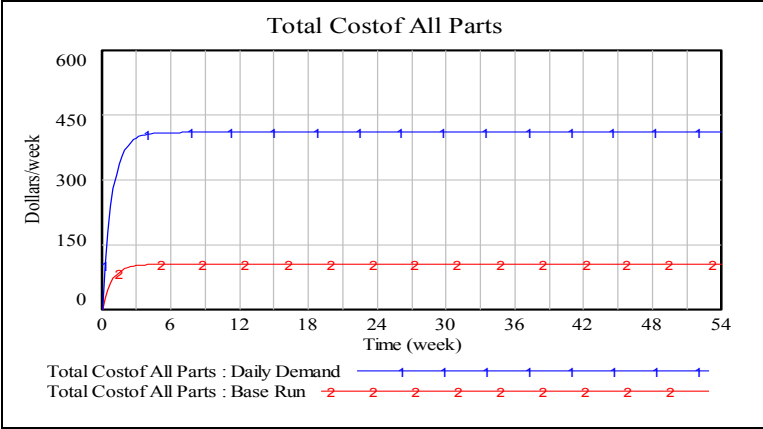

Figure 4.38 EOQ with Daily Demand Fluctuation.

From Figures 4.38 and 4.39 it is clear that change in the daily demand from say base run level to the 150 products per week, the total cost of all parts will increase significantly as shown in Figure 4.40.

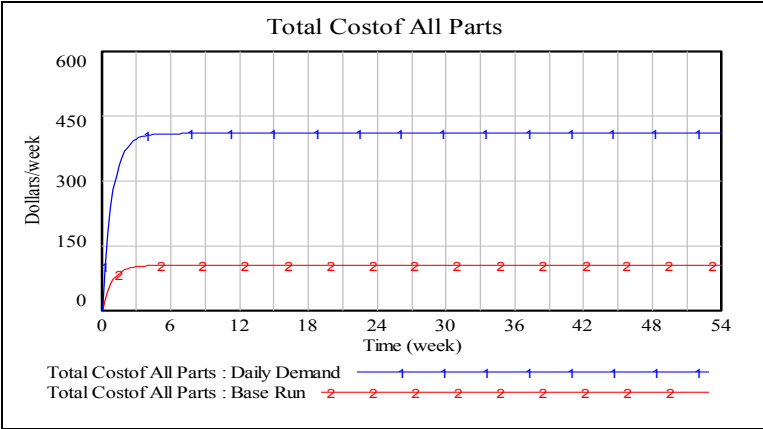

Figure 4.39 Total Cost of All Parts

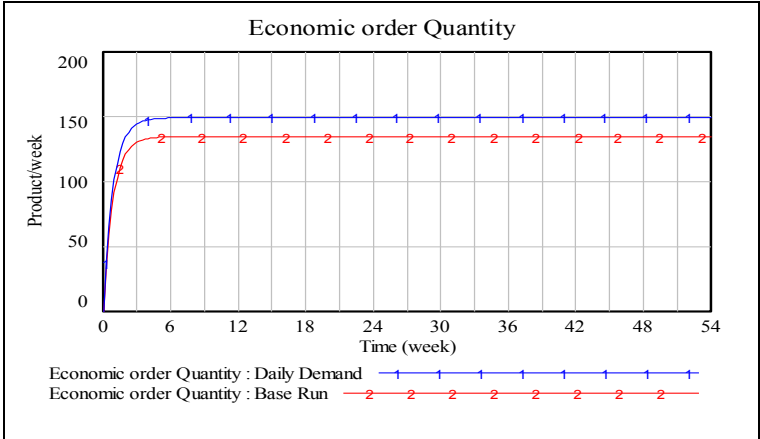

Figure 4.40 Total Cost of All Parts.

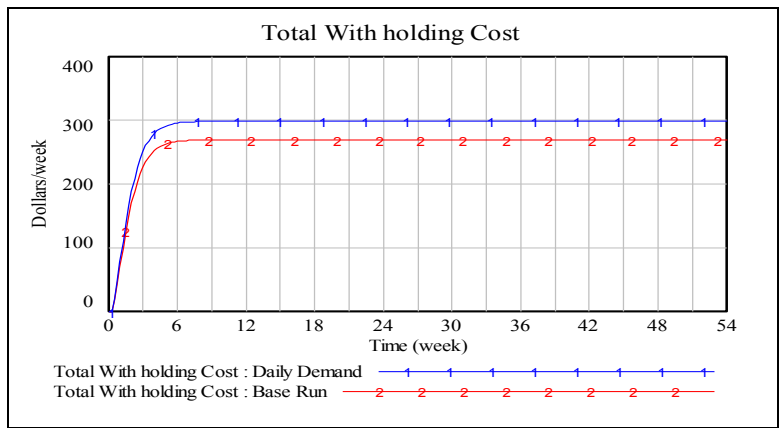

Figure 4.41 Total with Holding Cost.

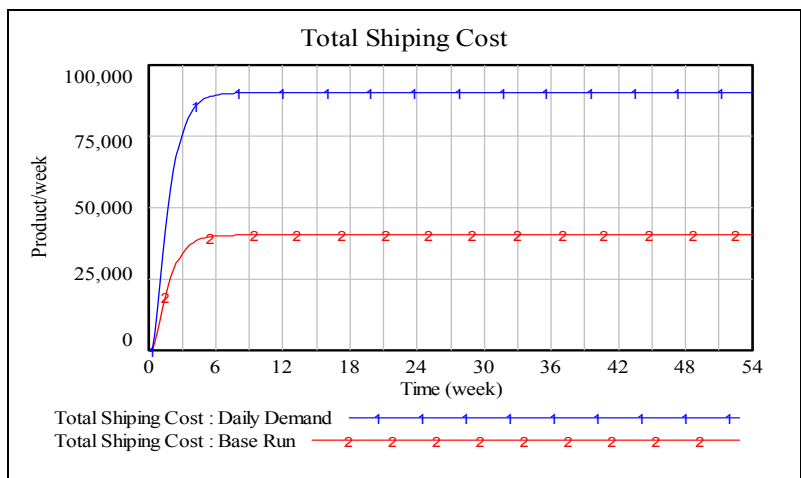

Figure 4.42 Total Shipping Cost

As described that the perturbation in the daily demand to increasing level as shown in Figures 4.41, 4.42 and 4.43 trend can result in the significant change in the magnitude of the total shipping cost and so as the overall total cost with a significant amount.

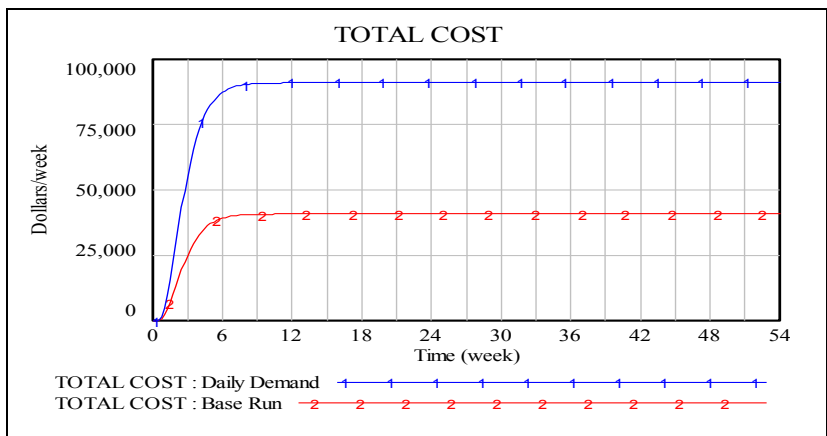

Figure 4.43 Total Shipping Cost

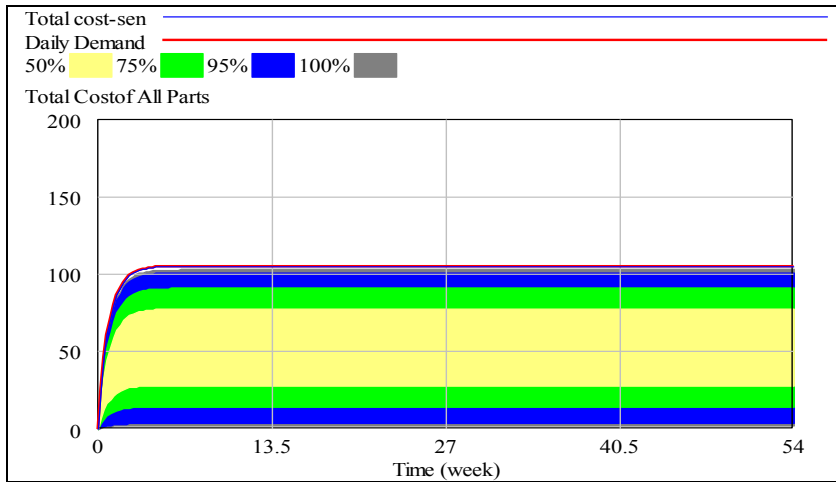

Figure 4.44 Total Cost of All Parts Multivariate Sensitivity

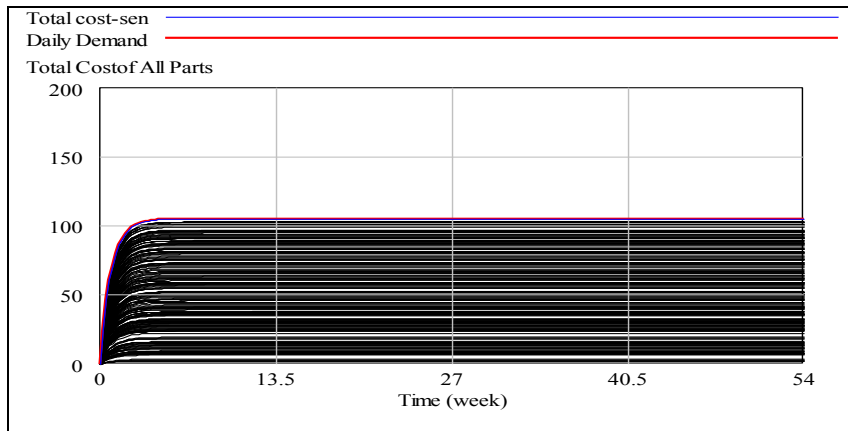

Figure 4.45 Total Cost of All Parts Individual Traces

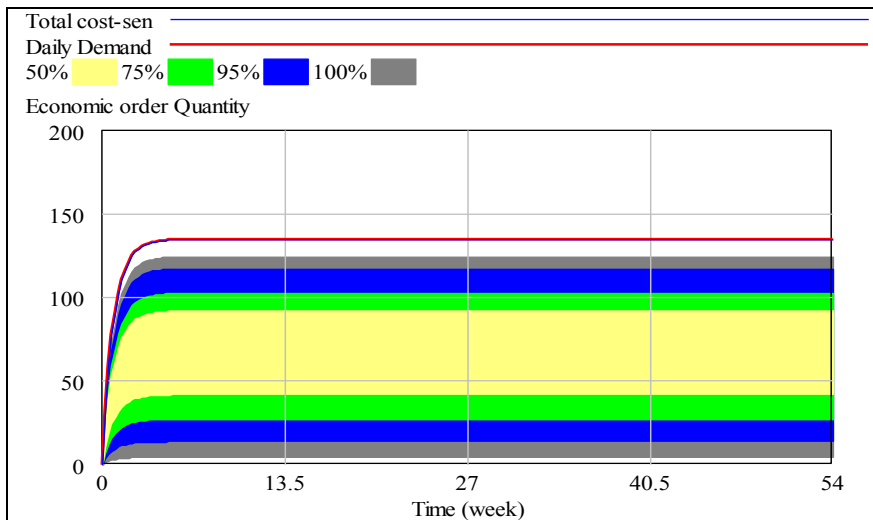

Figure 4.46 EOQ Multivariate Simulation

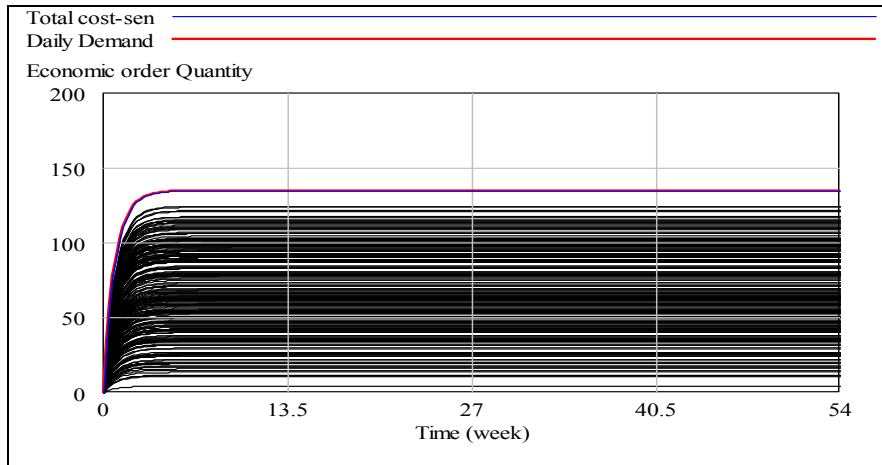

Figure 4.47 EOQ Individual Traces result.

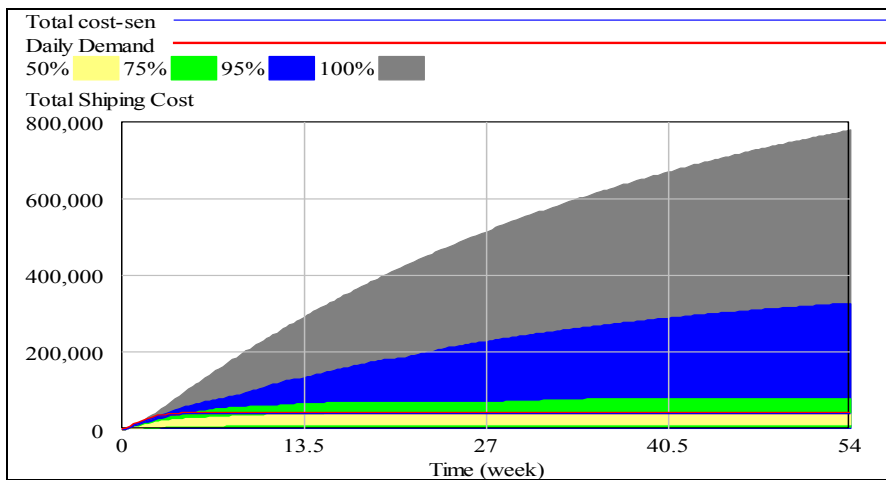

Figure 4.48 Total Shipping Cost Multivariate Sensitivity

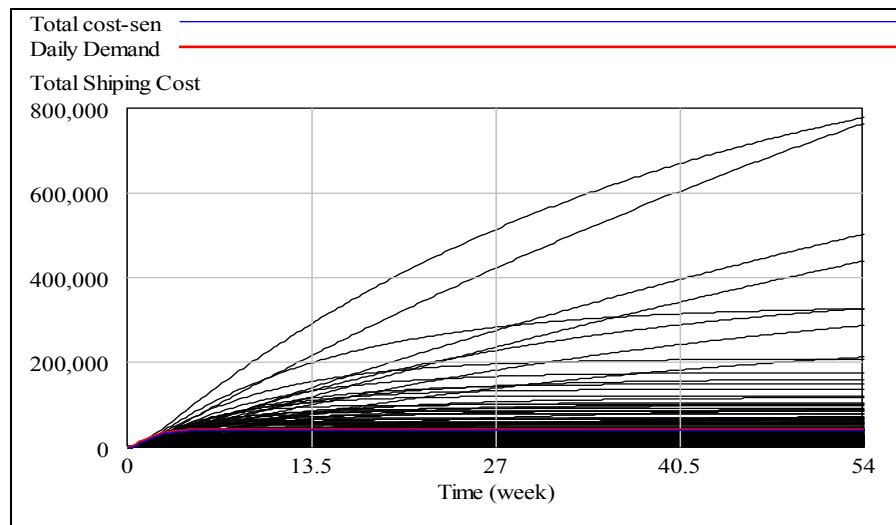

Figure 4.49 Individual Traces of Total Shipping Cost

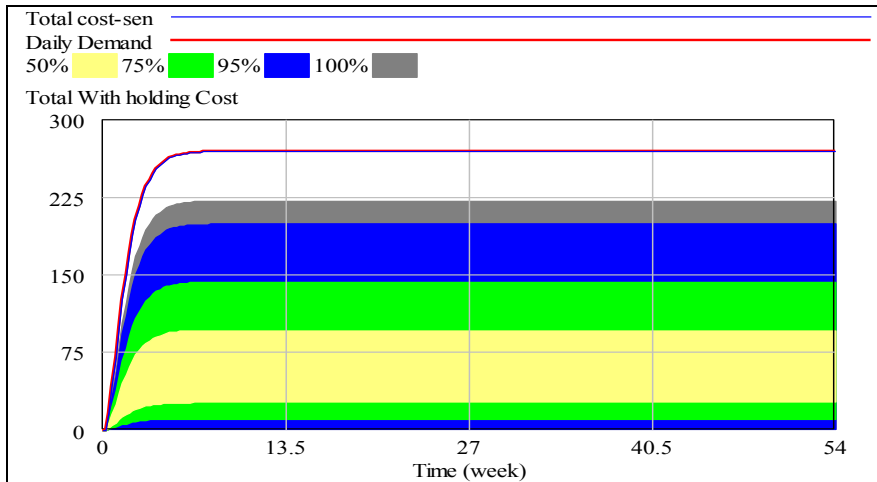

Figure 4.50 Total with Holding Cost Multivariate Sensitivity

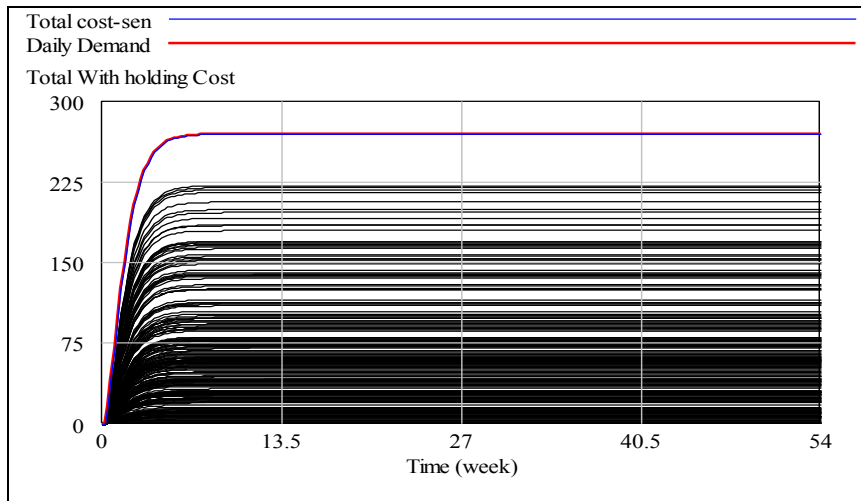

Figure 4.51 Total with Holding Cost Individual Traces

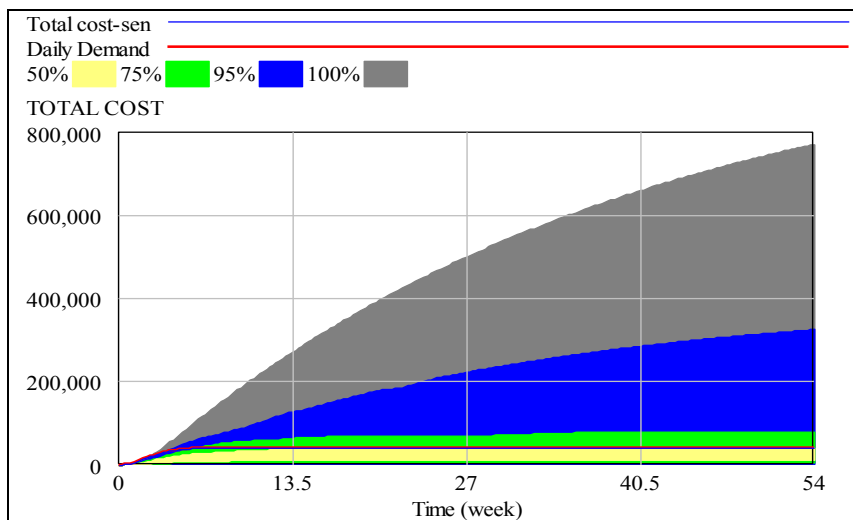

Figure 4.52 Total Cost Multivariate Sensitivity.

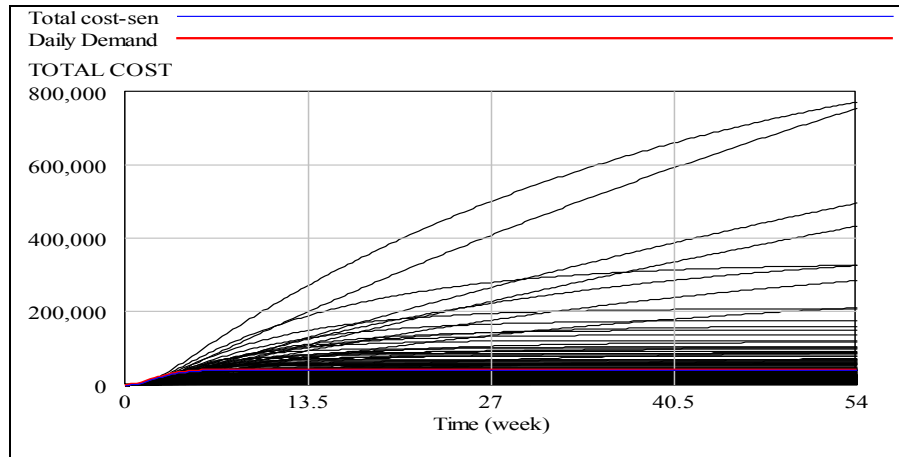

Figure 4.53 Daily Demand Individual Traces Sensitivity result.

This behaviour is quite visible in Figures 4.42 and 4.43 which show us the fact that dominating aspect in terms of cost is shipping cost aspect. As no matter which parameter is changed or variable is arranged this system will show and exhibit the same result patterns. Therefore, this is the point that today supply chain and shipping cost are the main key performance indicators (KPI) for the success of the business. As system gives sensitivity analysis results in Figures 4.44 through Figures 4.53 which not only validates the model but also give us the sensitivity at multivariate and individual traces level for having big picture and broader understanding horizon.

4.5 Sociotechnical Aspect of Assembly Process

As we move in to post industrial information and knowledge revolution, we find ourselves in a never ending continuous competitive development and ramp up for change in design and in process of production. Therefore, dynamism in the reconfigurable manufacturing system is the means to answer the newest market demands with agility. The flexibility of the manufacturing system was considered an aspect but reconfigurable manufacturing is the only way to cope with the customization and personalization market segments in the same production settings. But, it has been noticed that although the assembly processes become more and more automated, but the involving efficiency depends upon the range and degree of integration of effective integration of logical and soft enablers and physical and hard enablers. This partly depends upon the degree of human involvement and partly dependence on the process used for making of the artifact in question. No doubt, the fact that it is impossible for even human skilled operator as an

element of production to give satisfactory performance all time. One reason is stated in this context is very cogent which is that they are inconsistent, unreliable, and expensive. Therefore, the assembly system start depletion the sense of judgment, dexterity, strength, and flexibility, which is not uniform and consistent so it fades as the time possesses. According to ElMaraghy et al. (2003), effort is a function of physical or cognitive element that influences the task effort. In the following are the steps which include physical and cognitive elements of each component or process-related factors which are recognized for understanding the sociotechnical aspect of the assembly as such:

4.5.1 Physical Elements Related Issues

Some factors in the component and process-related complexity physically affect the effort amount. In the following section, first it describes the component related factors, and then the process related factors. Component related include the part geometry, surface specification, physical and material properties which are heavily and thoroughly assessed.

4.5.2 Assembly Process Related Issues

Here this category involves the tools/fixtures, relativity, assembly direction, joint positioning, part support, part stability, fastening type and required force and part stability.

4.5.3 Cognitive Elements Related Issues

Some factors in the component and process-related complexity cognitively affect the effort amount. In the following section, first we describe the component related factors, and then the process-related factors. Component related involves the part symmetry, like α -symmetry and β -symmetry and DFA method, assembly process related factors involve all the elements related to assembly operation, except for part relativity factor, that cognitively affect the assembly effort. A mathematical model as shown in Equations (4.16 and 4.17) are used to assess the assembly efforts is described in thesis of Shokori (2008) and later also applied by Ali-Qureshi (2011) as well for engineering analyses. After defining the handling, alignment, and insertion effort for all parts, the relative effort of assembly have been calculated for understanding the assembly system and finally applying DFA for ascertaining complexity in relative effort of assembly. As such after formulation of assembly complexity metric,

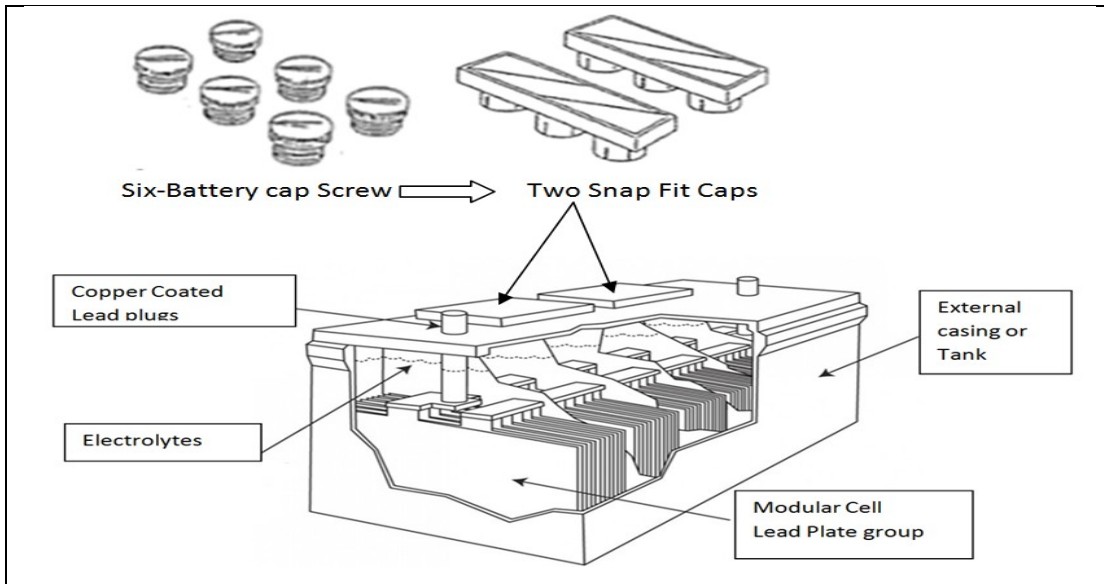

Figure 4.54 Isometric Drawing of Lead Acid Battery with parts (modified and adopted from Bart H. (2004))

the metric is analyzed based on its sensitivity to changes in different influencing elements. Figures 4.54 above illustrate the reaction of assembly complexity with respect to changes in the number of components, diversity of the components, and assembly effort, respectively. In this analysis, the elements are assumed independent. In other words, changing one element does not affect the other elements. Complexity index for pre-DFA and post-DFA analysis have been performed. However, for each part separate calculation has been made accordingly by Ali-Qureshi (2011), equations as listed in Nomenclature which illustrates the linear model Equations (13, 14 and 15) which are used to perform the analysis which later is transformed in to system dynamic model to study the behavior and its impact on the system from the equations as shown in nomenclature listed in the beginning we have :

$$\text{Complexity Index for Pre - DFA} = \text{Cass} = [\text{Dassy} + \text{REff}] * \text{Hass} \dots \dots \dots (4.16)$$

where $\text{RE}_{ff} = 0.7266$,

$$\text{Dassy} = n/N - 1 = 1/11 - 1 = 0.09 - 1 = 0.91$$

$$\text{And } H = \log_2(N+1) = 2.48 ,$$

Now by calculating and putting the values we get

$$\text{Cass} = [0.91 + 0.7266] * 2.48 = 4.$$

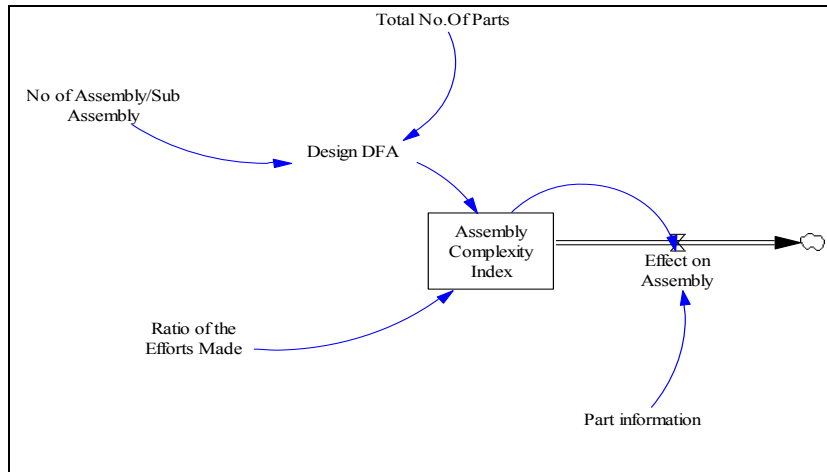

Figure 4.55 Modeling for Assembly Complexity Index

$$\text{Complexity Index for Post - DFA} = \text{Cass} = [\text{Dass} + \text{REff}] * \text{Hass} \dots \dots \dots (4.17)$$

where $RE_{ff} = 0.40236$,

$$\text{Dassy} = n/N - 1 = 1/7 - 1 = 0.1428 - 1 = 0.85 \text{ And}$$

$$H = \log_2(N+1) = 2.079,$$

Now by calculating and putting the values we get

$$\text{Cass} = [0.85 + 0.4036] * 2.07 = 2.606$$

Case Study No-4.6

Now transforming Equations (12-15) from the List of nomenclature equations and modeling to understand the behavior of the system using system dynamics. In order to look in to the crux of the issue deeply we model complexity with as variables are shown in Figure 4.55 the attribute variable and definitions are presented in Table 4.11 and their respective parameters definitions and values are shown in Table 4.12 and presented in Equations (4.16) and (4.17) for analysis of dynamics and evolutionary affect on the system behavior which is under focus of study. Let us consider following for modeling the facts as firstly we take the

Initial time

$$T_i = 0$$

Final time

$$T_f = 5$$

Time Step:

$$dT = 0.25$$

Units of time =Year

Any instant T:

$$T = \sum_i^n 0.25 \times n + Ti \dots\dots\dots (4.18)$$

Where $n = \frac{Tf - Ti}{\Delta T}$

Table 4.11 Variables Definition for Case Study # 4.6

Variable name	Variable Definition
Assembly Complexity Index	This variable is very important and dependable on associated variable But important is the fact that property of this variable affects the whole system in such a way that it predicts the major behaviour of the whole system
Number of assembly / sub assembly	This variable refers to the modular sub assembly parts which are in itself has important impact factor more parts in the top assembly produces more complexity.
Efforts ratio	This variable is the core in such a way that it is direct and provides effective impact on the whole system as more efforts are made, means more complexity is indeed there.
Total number of parts	This variable reflects in the assembly complexity as such if it has more parts in the assembly system this means it will affect on the system.
Part information	The complexity of information can affect the system behaviour as well , more complex design has more complex information which down the road affect the output of the system

Table 4.12 Base Case Variables for Case Study # 4.6

Serial No	Parameter definition and Unit Value
1	Total number of parts= $T_{PARTS} = 0.91$,with given DMNL units
2	No of assembly/ sub-assembly= $N_{ASS} = 1$, with given DMNL units Design for DFA = D_{DFA}
3	Ratio of efforts made= $R_{EFFORT} = 0.7266$
4	Assembly complexity index= ASS-COMPLEX-INDEX
5	Part Information = $P_{ART-INFO} = 2.48$

Therefore the Design for Assembly (DFA) value we can have for the initial time T_i from the following relation with given DMNL units.

$$(Design\ for\ DFA)D_{DFA} = (No\ of\ Assembly/\ Sub-Assembly) N_{ASS} * 1 / (Total\ number\ of\ parts) T_{PARTS} ; D_{DFA} = N_{ASS} * 1 / T_{PARTS}$$

Now for finding the complexity index at the final time T_f with given dimension less units (DMNL) units we have the following Equation (4.19) as such

$$ASS - COMP - INDEX(T_f) = \int_{T_i}^{T_f} [(D_{DFA} + R_{EFFORT}) \times P_{ART - INFO}] * dT + ASS - COMP - INDEX(T_i) \dots \dots \dots (4.19)$$

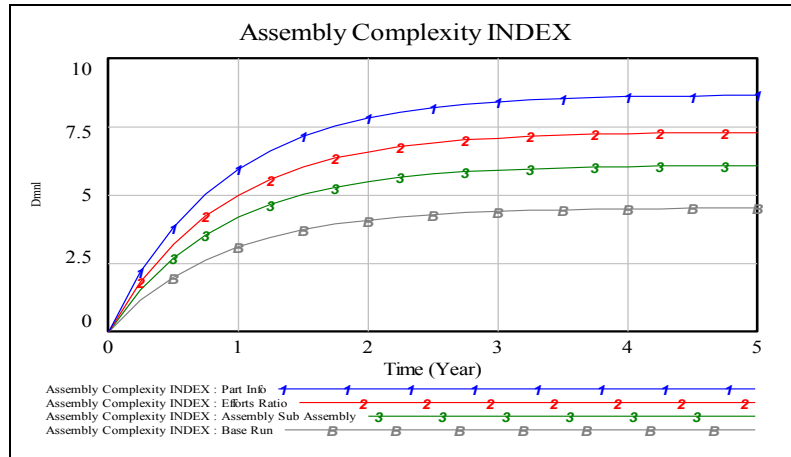

Figure 4.56 Results of Assembly Complexity Index

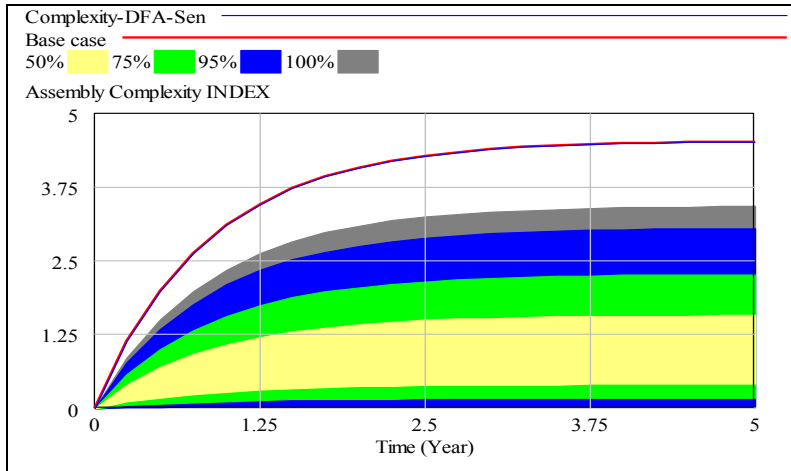

Figure 4.57 Multivariate Sensitivity.

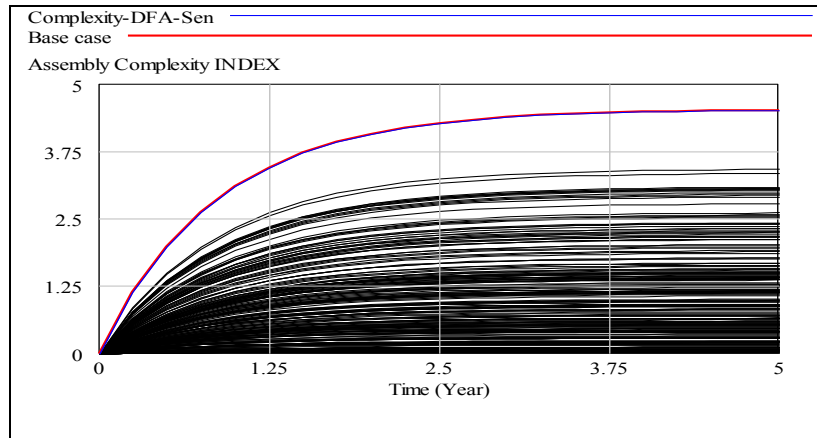

Figure 4.58 Individual Traces of Assembly Complexity Index

As we see, the behavior of the system from Figure 4.56 as such that the logistic curve appears to show us the fact that the more we change the variables parameters it affects the resulting magnitude of the assembly complexity. As it can be notice from Figure 4.56 when sub assemblies are reduced and also more ratio of the affords means more parts same as more sub assemblies which will in turn affect the complexity index magnitude by increasing trend from the lower level towards higher level. And as such we can conclude that higher index which means higher complexity. Which is also evident from sensitivity analysis of multivariate and individual traces that perturbation in the variable values will result in higher magnitude of complexity as shown in Figures 4.57 and 4.58. This does not only validates the model but also provides the broader perspective of the system.

Case Study # 4.7

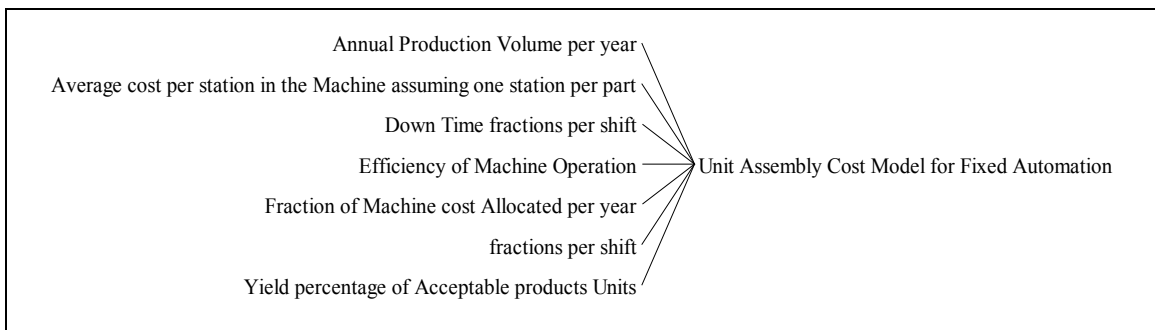

Figure 4.59 Key Attributes of Unit of Assembly Cost for Fixed Automation

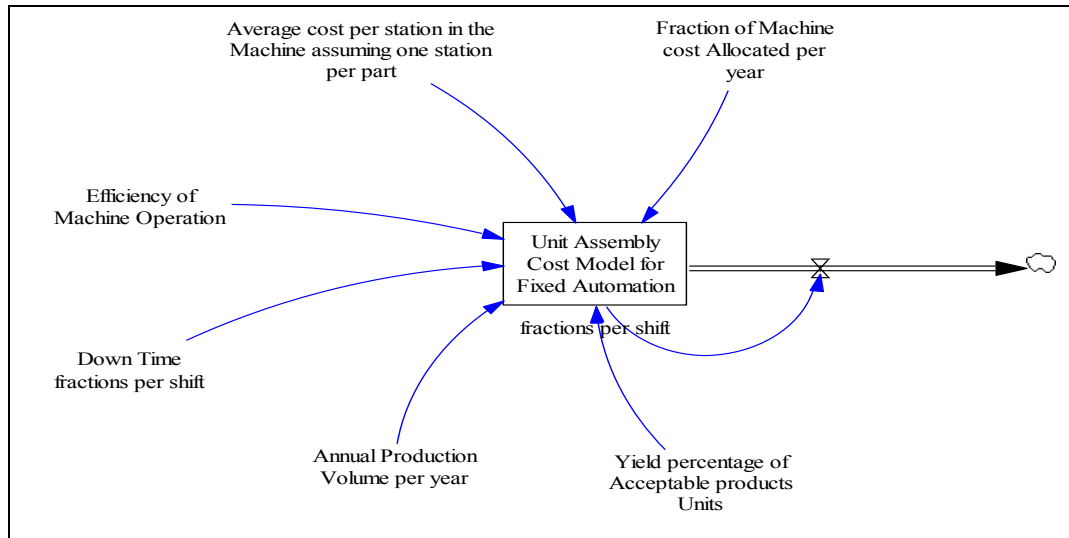

Figure 4.60 Modeling Sketch of Unit Assembly Cost for Fixed Automation.

Now, at this point, this research consider which type of the cost will influence more when it comes to the assembly of the parts in case of fixed automation then in this regard we have the following key variables and parameters from the Equations (5 to 11) concepts as listed in beginning of the dissertation. Model and key attributes relations are shown in Figures 4.59 and 4.60. Besides, the variables are defined in the Table 4.13 and the parameters of the base case are define in Table 4.14.

Table 4.13 Variable Name and Definition for Case Study # 4.7

Variable name	Variable Definition
Annual labour cost	Labour or man hours on machine tools for completion of a given task.
Annual production volume	This is a volume of products required to be produced per year. Usually, it is the target goal to be achieved.
Assembly time per part of the Component	This is the time which is required to be worked out for modular assembly part.
Number of hours per shift	This is the number of hours in the shift which is required
Production yield	Percentage of the product passed and cleared by the quality and inspection.

Table 4.14 Base Case Variables for Case Study # 4. 7

Serial No	Parameter Definition and unit values
1	<i>Annual production volume=AprVol = 25000 with units of products /year</i>
2	<i>Average cost per station Cmachine Station = CmS = 25000 with units of dollars</i>

3	<i>Down time of the machines Dtime Station = DtS = 35 in minuts</i>
4	<i>Efficiency of operator= EmO=98*1/100</i>
5	<i>Cost of machine /year=CmY=10000 in dollars /year.</i>
6	<i>Percentage of the acceptable products= Yields=Y=96*1/100</i>

Let us consider for the model the facts that firstly we take the

Initial time

$$T_i = 0$$

Final time

$$T_f = 10 \text{ years}$$

Time Step:

$$dT = 0.125$$

Any instant T:

$$T = \sum_i^n 0.125 \times n + T_i \dots \dots \dots (4.20)$$

Where $n = \frac{T_f - T_i}{\Delta T}$

Whereas let us consider the annual production volume supposedly is in initial time in terms of product per year are as such

$$AprVol = 25000$$

Whereas it is assumed that the average cost per station in the machine one station per part is given as in terms of initial time and units of dollars as such *Cmachine Station = CmS = 25000 dollars.*

Let us assume that the down time of the machines initial time in terms of units of minutes are assumed as per shift then we have *Dtime Station = DtS = 35 min*

Let us assume that the efficiency of the machines operator in terms of percent at the initial time is given as efficiency of operator= EmO=98*1/100

Let us also assume that the machine maintenance cost which is necessary and budgetary allocation for this purpose is considered at initial in terms of dollars as such cost of machine /year=CmY=10000 dollars

Similarly, consider the percentage of the acceptable products at the initial Time in terms of percents, Yield=Y=96*1/100

Therefore, now the unit assembly cost for fixed automation at the final time T_f , in terms of dollars is determined by Equation (4.21) as such

$$Cost_{assembly_Fixed-Automation}(T_f) = \int_{T_i}^{T_f} [(CmY \times CmS \times 1 / AprVol \times Y) \times 1 / EmO - DtS] * dT + Cost_{assembly_Fixed-Automation}(T_i) \dots \dots \dots (4.21)$$

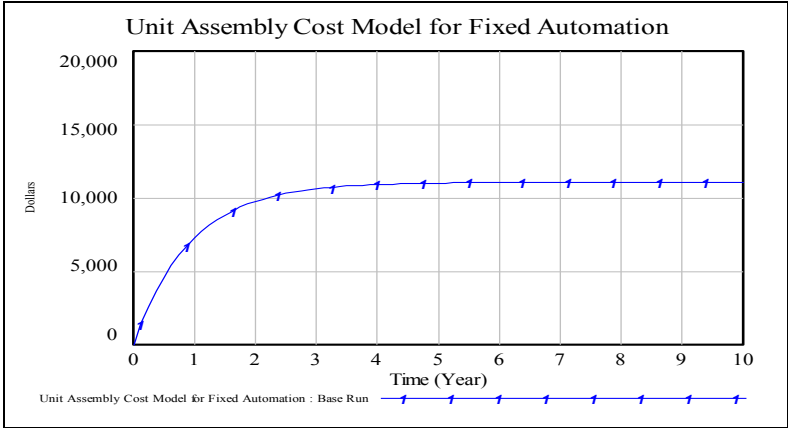

Figure 4.61 Unit Assembly Cost for Fixed Automation

The simulation reveals the fact that with the Yield of 98 % and increase of production volume to about 10 thousand will enable us to reduce the unit assembly cost compare to the other parameters provided that the conditions are not changed with regard to the influencing parameters likewise the average cost per machine and fraction of machine cost allocated remain undistributed for fixed unit assembly automation as shown in Figures 4.62 and 4.63.

Similarly, if the fraction of the machine allocated cost is altered then this influences the magnitude as shown in Figure 4.62 which is a logistic growth curve. If a fraction of machines is perturbed from the base run case then no change in the behavior pattern is found. The case of the Average cost per station as shown in Figure 4.63 which is also a logistic growth curve is similar.

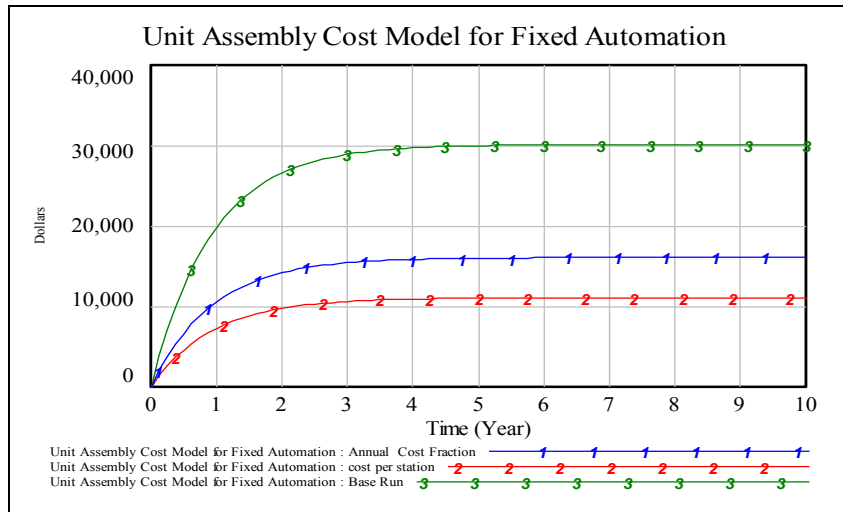

Figure 4.62 Fraction of Machine Cost Influence

Similarly, if the fraction of the machine allocated cost is altered then this influences the magnitude as shown in Figure 4.62 which is a logistic growth curve, if fraction of machines perturbed from the base run case but not the behavior pattern.

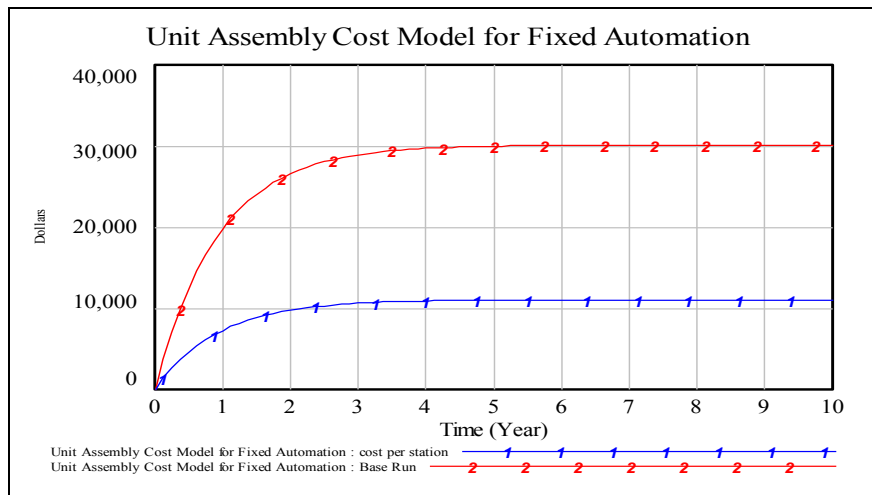

Figure 4.63 Influence of Average Cost Per Station

Similarly, is the case of the average cost per station as shown in Figure 4.63 is also a logistic growth curve. While yield remains the same which is very important and decisive factor in decision making. Figure 4.64 and 4.65 show unit cost for fixed automation and multivariate simulation illustrates the variation in the intensity of the magnitude, while overall system behavior remains the same. This also validates the model and allow us to consider what difference it can make if the unit assembly cost is managed by scenario of manual processes only.

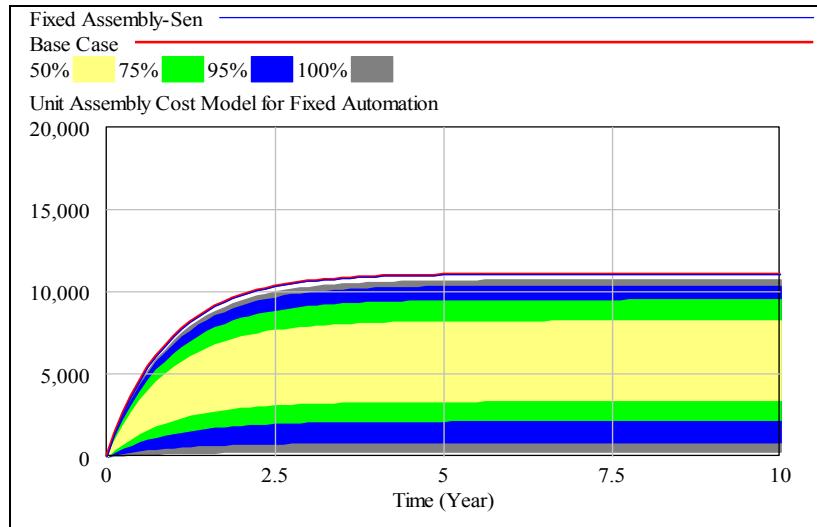

Figure 4.64 Unit Cost of Assembly Multivariate Sensitivity

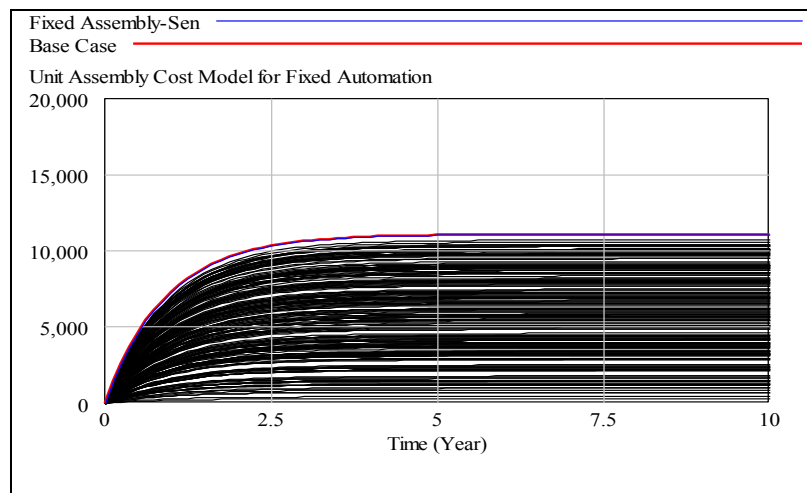

Figure 4.65 Individual Traces of Unit Cost for Fixed Automation

This makes us to consider the fact that what differences will it make if the unit assembly cost is managed by the manual processes only. Next, the results of the multivariate sensitivity and individual traces which are shown in Figures 4.64 and 4.65 reflect the fact that the no matter what the magnitude of intensity is the behavior pattern will remain the same. At this juncture, we change our study focus which leads us to model for manual assembly processes as shown in Figures 4.66, 4.67 and 4.68. By using Equations (5 to 11) concepts from the nomenclature listed at the beginning of dissertation.

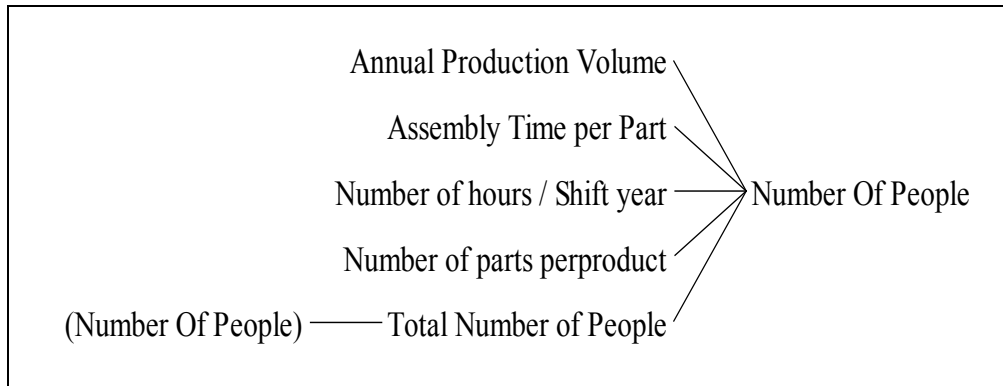

Figure 4.66 Key Attributes in Modeling Unit Assembly Cost

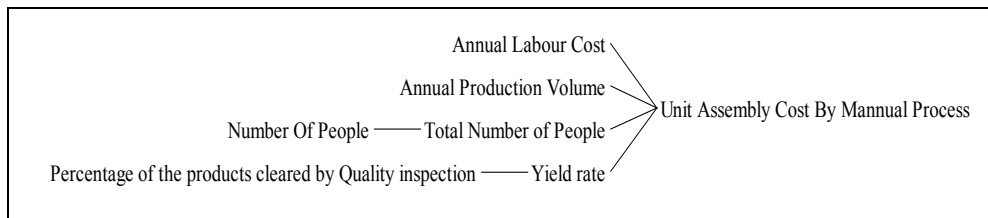

Figure 4.67 Key Attributes in Modeling Unit Assembly Cost through Manual Assembly Processes.

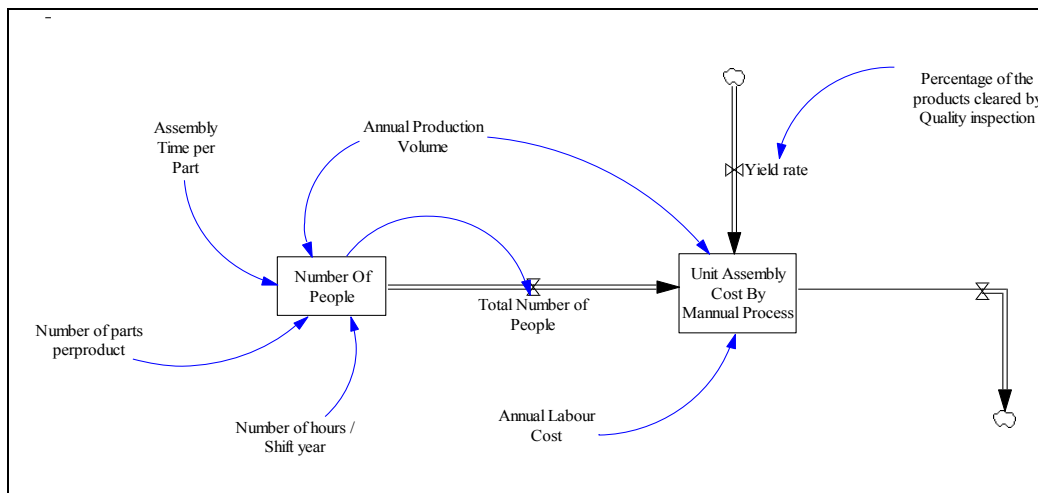

Figure 4.68 Modeling of Unit Assembly Cost through Manual Process.

Case Study #4.8

Let us consider for the model the facts that firstly we take the

Initial time

$$T_i = 0$$

Final time

$$T_f = 100 \text{ Minutes}$$

Time Step:

$$dT = 0.25$$

Any instant T:

$$T = \sum_i^n 0.25 \times n + T_i \dots\dots\dots (4.22)$$

Where $n = \frac{T_f - T_i}{\Delta T}$

Whereas let us consider the annual labour cost for the assembled product can be taken as *Al* in terms of units of dollars per minutes thus at the initial time is given by as such:

$$Al = 1 * 0.5 \text{ dollars/min}$$

Similarly, consider the annual production volume suppose *Apr* Thus at the initial time T_i in terms of product units /sec

$$Apr = 25 \text{ sec}$$

Now consider the assembly time per part of the component of the product are taken at initial time T_i in terms of minutes as such that $Pat = 3.6 * \frac{1}{60} \text{ min.}$

Let us consider the number of hours per shift which are required for running shift in a year suppose at the initial time T_i in terms of minutes of time as such

$$Hshift = 2000 * \frac{1}{60}$$

Whereas it is assumed that 7.5 hr shift will last for 7 days of week for whole year round figure of 2000 hr is taken, excluding the holidays. Let us assume that suppose there are significant number of the parts in a product at initial time T_i in terms of units of the product are given by

$$\frac{N_{part}}{product} = 100 \text{ products}$$

Similarly the percentage of the product passed and cleared by the quality and inspection consider that initial time T_i in terms of the percents of units then as such:

$$Qins = 99 * 1/100 \text{ percentage}$$

Therefore yield rate can be considered at the initial time as such that at the initial time T_i in terms of percent as it is cleared by the inspected and passed by the quality therefore,

$$Yr = Qins$$

While total number of the people in terms of labour involved are considered as the number of people at initial time T_i as such in terms of person.

$$N_{total} = N_{labour}$$

Table 4.15 Variable Name and Definition for Case Study # 4.8

Variable name	Variable Definition
Annual Labour Cost	This is the cost variable which is associated with the production of the assembled product which required labour or man hours on machine tools for completion of given task.
Annual Production Volume	This is a sale volume which is usually the target goal to be achieved This variable is important where it has impact on the behaviour of the system.
Assembly Time per Part of the Component	This is the time which is required to be worked out for modular assembly part.
Number of Hours per Shift	This is the variable time which is needed to assemble a product
Production Yield	It is the percentage of the product passed and cleared by the quality and inspection is a very important variable which shows the real outcome of the production and manufacturing system

Table 4.16 Base Case Variables for Case Study # 4.8

Serial No	Parameter Definition and unit values
1	Annual labour cost for assembling the product $Al = 1 * 0.5$ in dollars/sec
2	Annual production volume= $Apr = 25$ in products / units/minutes
3	Assembly time per part of the component= $Pat = 3.6 * \frac{1}{60}$ in minutes
4	Number of hours per shift= $Hshift = 2000 * \frac{1}{60}$ in minutes
5	Percentage product passed and cleared by the quality and inspection $Qins = 99 * 1/100$

Therefore now the N_{labour} at the final time T_f in terms of persons unit as such can be determined by Equation (4.23) given as

$$N_{Labour}(T_f) = \int_{T_i}^{T_f} (Apr + Pat + Hshift + Npart / product) * dT + N_{Labour}(T_i) \dots \dots \dots (4.23)$$

Similarly, the total number of people can be obtain by equation (4.24) as such

$$Ntotal(Tf) = \int_{Ti}^{Tf} (Apr + Pat + Hshift + Npart / product) * dT + Ntotal(Ti).....(4.24)$$

Thus unit assembly cost by the manual assembly process can be taken as in final units T_f of time and determined by the Equation (4.25) as such that

$$C_{Assembly}^{Manual Process}(Tf) = \int_{Ti}^{Tf} (Al + Ntotal \times 1 / Apr \times Yr) * dT + C_{Assembly}^{Manual Process}(Ti).....(4.25)$$

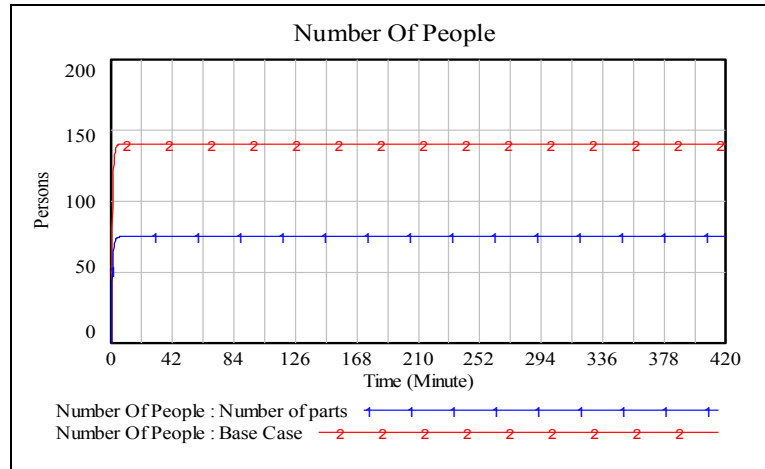

Figure 4.69 Number of People.

In this context, we model the above Equations (4.23) to (4.25) then it has been learned that If the number of the parts are increased in product then more number of people will be needed as shown in Figure 4.69.

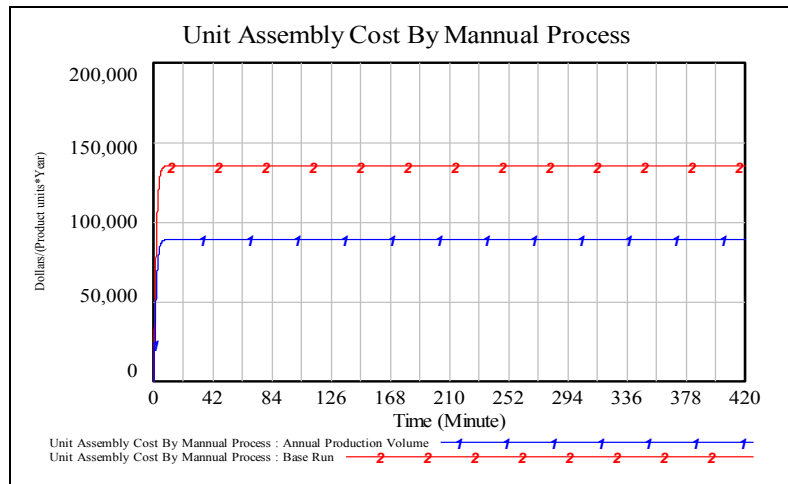

Figure 4.70 Unit Assembly Cost.

If the yield rate is increased then this will significantly increase the unit assembly cost by manual assembly process as shown in Figure 4.70. This reflects the fact that the annual

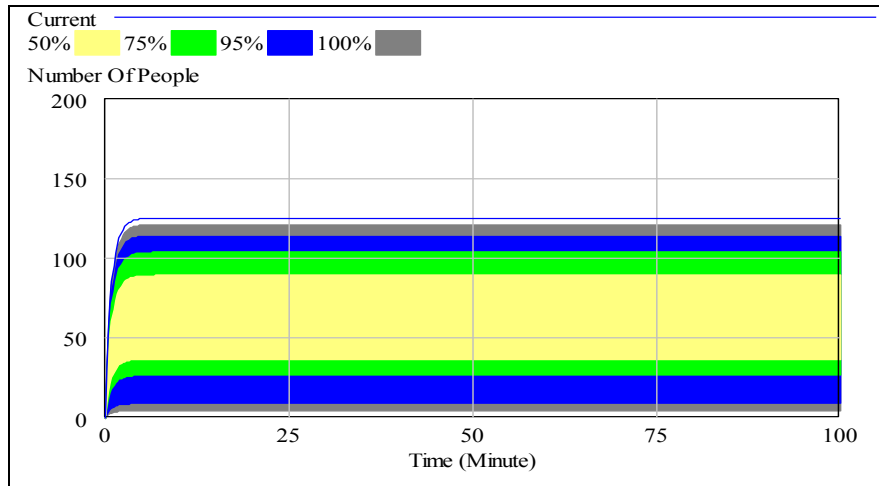

Figure 4.71 Number of People Multivariate Sensitivity

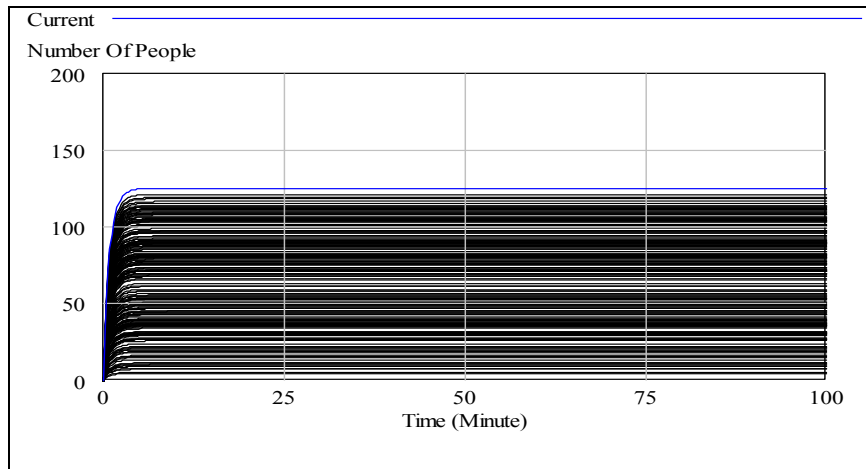

Figure 4.72 Individual Traces of Sensitivity

production volume has great influence on the system as well and small perturbation can result a much bigger monetary loss. Here, we do a test to change time which was extended to 420 minutes of the shift work to understand the gravity of the magnitude and its impact on the system horizon. In this particular case it is found that besides the parameters even if we change the time for simulation run it will not affect the behavior pattern of the system as shown in Figures 4.71 and 4.72 of multivariate sensitivity and in individual traces, respectively. This brings us to another issue which is directly associated with the components and parts which creates trouble, if the number of parts increased in assembly and sub assembly, it will produces the complexity. Here we look in to a quite different nature of the ramp-up problem in the following case study as such key attributes are shown in Figure 4.73 and new model in Figure 4.74 as such.

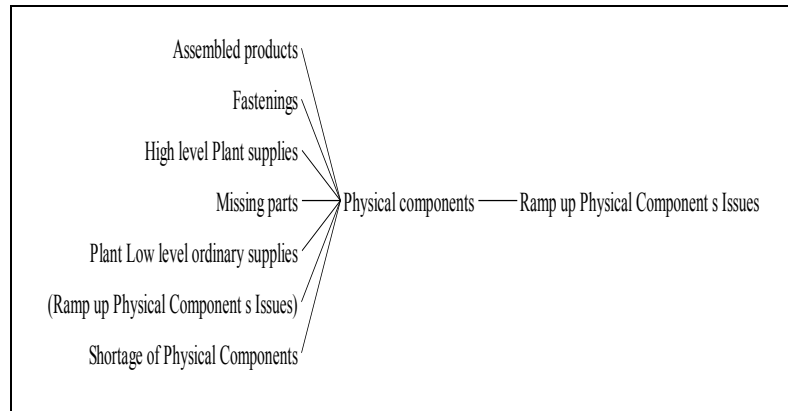

Figure 4.73 Ram-up Physical Component Issues Key Attributes.

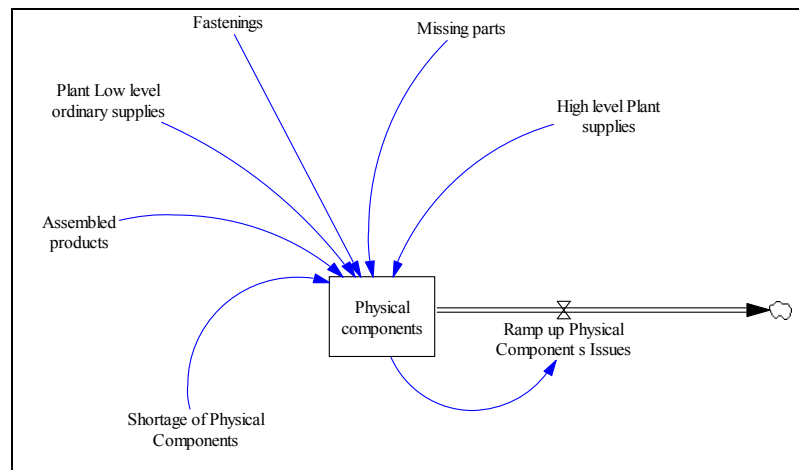

Figure 4.74 Modeling Sketch of Ramp-up Component Issues.

Case Study # 4.9

In this regard, Table 4.17 presents the variable definition for the case study and the Table 4.18 shows the parameters definition and their respective values which are used for the base case.

Table 4.17 Variable Name and Definition for Case Study # 4.9

Variable Name	Variable Definition
Assembled Product Number	This variable is the count of the numbers of the actual assembled product , variation of which may result good or adverse effects on the production
High Level Plant Supplies	This variable concept is those plant supplies which are very necessary for production
Fastening Parts of the Product Component	This variable has the parts which has the variable of temporary fastening. However, in some cases permanent fastening is used for assembly like commercial riveting for air line industry and welding for boilers etc.
Plant Low Level Ordinary Supplies	These are the supplies which are considered ordinary but still play important role as such machine oil or cotton clouth for hand cleaning etc

Parts Misplaced	This is the variable which may occur due to the fact that the human error or the material handling devices has been loaded with somehow with un intended parts.
-----------------	---

Table 4.18 Base Case Variables for Case Study # 4.9

Serial No	Parameter definition and unit value
1	The assembled product number= $A_{pi}=4$ in units of percents
2	<i>high level plant supplies</i> = $H_{pSi} = 19=$ in units of percents
3	Fastening parts of the product components= $F_{pi}=12$ in units of percents
4	<i>Plants low level ordinary Supplies</i> = $L_{oSi} = 13$ in units of percents
5	Initially an average of missing parts or misplaced= $M_{pi} = 8$ in units of percents
6	Shortage of physical components and parts= $S_{pCi} = 56$ in units of percents

Let us consider for the model the facts that firstly we take the

Initial time

$$T_i = 0$$

Final time

$$T_f = 720 \text{ Minutes}$$

Time Step:

$$dT = 0.125$$

Any instant T:

$$T = \sum_i^n 0.5 \times n + T_i \dots\dots\dots (4.26)$$

$$\text{Where } n = \frac{T_f - T_i}{\Delta T}$$

Whereas let us consider the number of product assembled can be abbreviated as A_p thus at the initial time in units of percents involving issues is given by as such: $A_{pi}=4$ percent

Similarly fastening parts of the product components can be abbreviated as Fp Thus at the initial time T_i in units of percents involving issues related to the $Fpi=12$ percent

Similarly *high level plant supplies* if any involving presumably which can be abbreviated as such HpS at initial time T_i in the units of percents involving related issues supposed particular to the product is given by $HpSi = 19$ percent

Similarly the *plants low level ordinary supplies* can be abbreviated as $LoSi$ and taken at the initial time T_i in units of percentage involving issues can be supposed as $LoSi = 13$ percent

Now let us suppose that initially an average of missing parts or misplaced at initial time in percentage the value of which is considered as such by the $Mpi = 8$ percent

The shortage of physical components and parts related issues owing to its supply chain work in process inventory which reflects the internal and external logistics and also determines the automation level along with flexibility to accommodate new design changes etc involve significance issue related to the facts at initial time T_i in given units percentage as such $SpCi = 56$ percent

It is worth to note the fact that the perturbation in terms of the data which is taken at the initial time T_i the significant of behavior change has been noted in terms of magnitude. However, the behavior pattern remains the same. Therefore, this signifies that ramp up of physical component related issues can be determine over all by taken in to account at final time Tf as such in units of percentage and given in Equation (4.27)

$$\begin{aligned}
 & Ramp - UP_{Physical\ component}(Tf) \\
 &= \int_{T_i}^{T_f} (Api + Fpi + HpSi + LoSi + Mpi + Spci) * dT + RampUP_{Physical\ component}(Ti).....(4.27)
 \end{aligned}$$

Thus it can be deduce that when the total rate of ramp-up physical component issues with which its effects in terms of percentage units conjuncture with above cited issues is given in Equation (4.28) as such

$$RampUP_{Physical\ component}(T_f) = \int_{T_i}^{T_f} (A_{pi} + F_{pi} + H_{pSi} + L_{oSi} + M_{pi} + S_{pci}) + I_{iDFA} * dT + RampUP_{Physical\ component}(T_i).....(4.28)$$

It has been learned from the simulation result shown in Figure 4.75 that influencing pattern remains the same however with difference in magnitude in terms of missing parts and fastenings, high and low level supplies physical components will remain a constant. physical component multivariable sensitivity is shown in Figure 4.76 the result demonstrates that 95 percentile is achievable from lower bound to upper bound random variable value. But, a great number of the grey area exist which shows that there is still great deal of the issues within the boundary of the system the variation of which can affect the system. The Multivariate also validates the results of the discrete event simulation and so as the model of the system under focus of study.

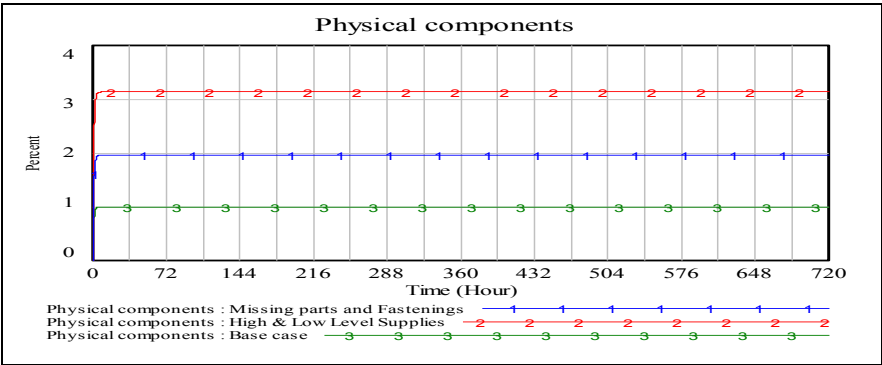

Figure 4.75 The Ram-up Physical Component Issues

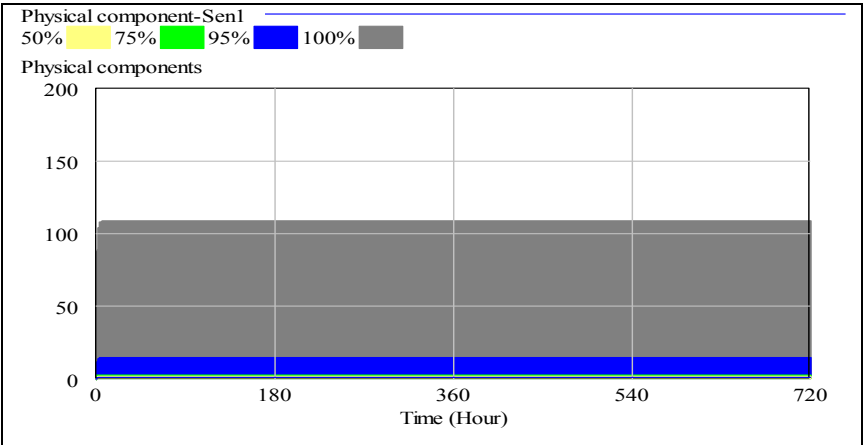

Figure 4.76 Physical Component Multivariate Sensitivity.

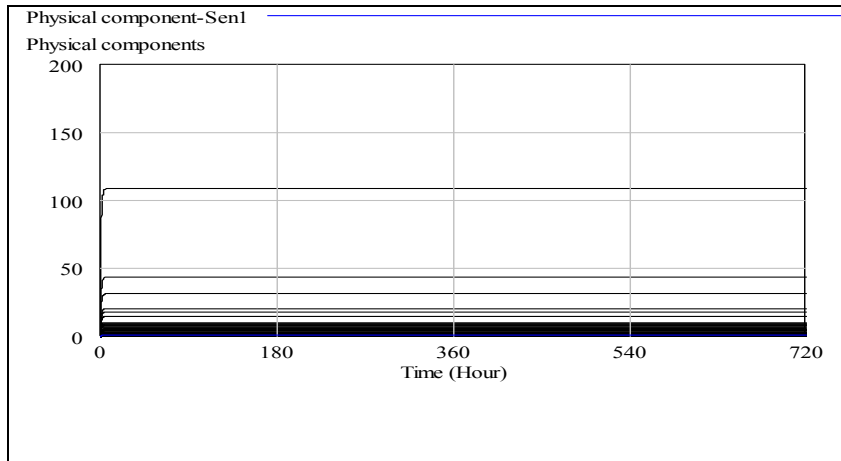

Figure 4.77 Physical Components Individual Traces

Physical components individual traces as shown in Figure 4.77 have a very persistent behavior pattern. This brings our research to look the issue of integrated analysis of the total feed cost involving auto feed key attribute of which are shown in Figure 4.78. and studied Case Study # 4.10.

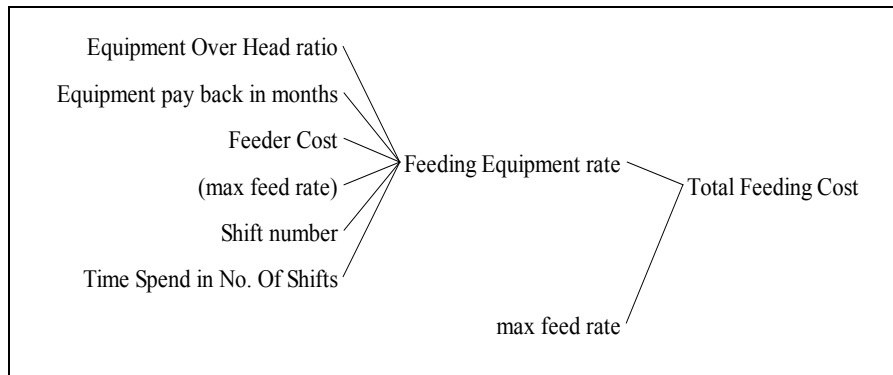

Figure 4.78 Key Relation for Automatic Feeding

Case Study # 4.10

Automatic feed have some key attributes of the model as described by Boothroyd (2005) and relevant modeling equations are mentioned in list of nomenclature Equations (5 to 11) as such which are helpful for forming our analysis in this context Figure 4.78 and 4.80 show the total cost of the manually loaded magazine as rate of the assembly worker and hence total feeding cost of the manually loaded magazine. Similarly, a complete model for determining the cost of automatic and manual feed as shown in Figure 4.79 while Figures 4.78 and 4.80 show the key attributes and their conceptual interrelation.

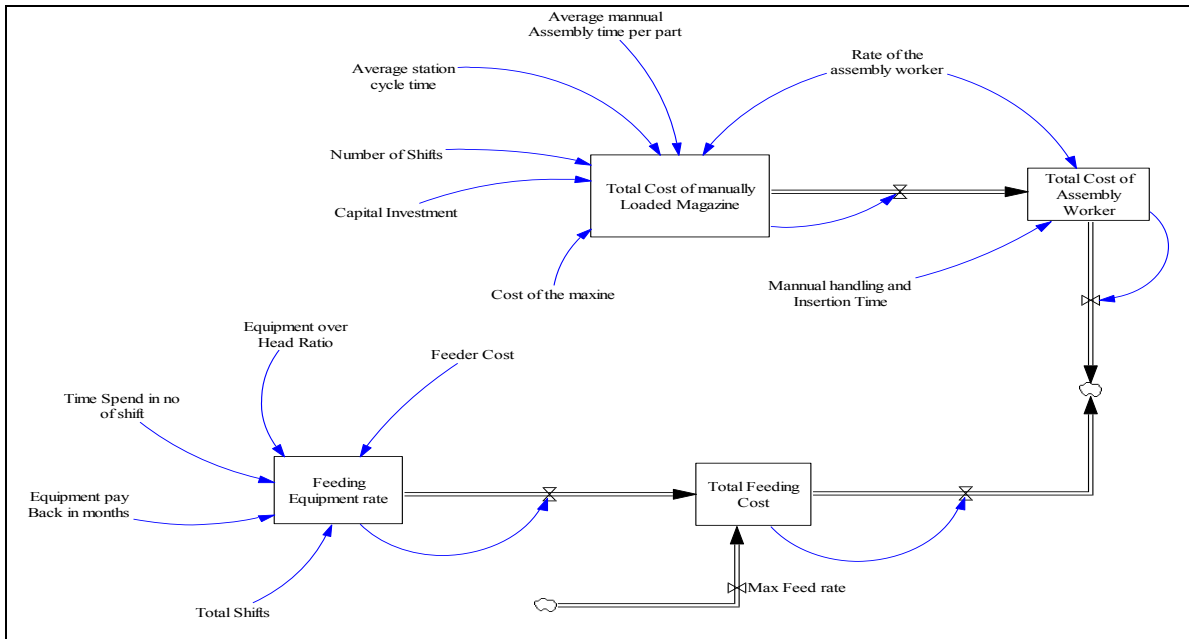

Figure 4.79 Modeling the Cost of Loaded Magazine with Automatic and Manual Feed

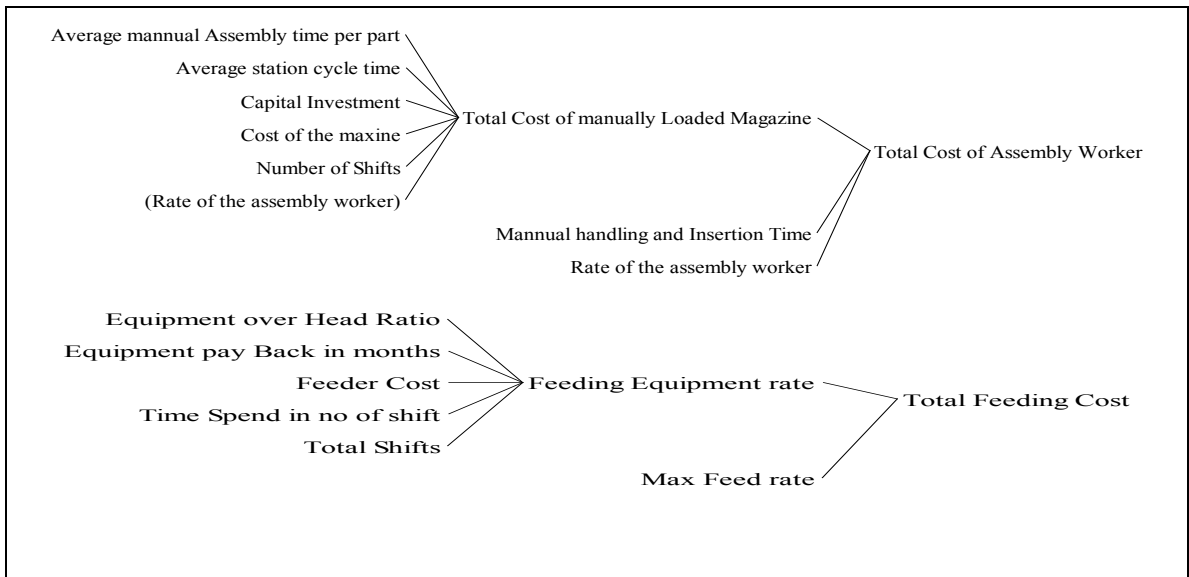

Figure 4.80 Key Attributes of Manually Loaded Magazine and Manual Handling

In this context, we define the base case variables as shown in Table 4.19 and their respective parameter definitions and base case variable values as given in Table 4.20.

Table 4.19 Variable Name and Definition for Case Study # 4.10

Variable Name	Variable Definition
Average manual assembly time per part	This is the variable which defines the average standard time for manual assembly operation.
Average station	This variable defines the cycle time of the average manual

cycle time	assembly process at a work station.
Capital investment	This variable defines the input of cost to bring change in the system
Cost of magazine	This variable is given in terms of the cost which may be automatic or manually loaded and work with gravity action as well.
Equipment over head ratio	This is the over head cost associated with the particular equipment
Feeder cost	This variable is defined as the cost actually occurring to feed the load of un processed material. This may be manual feed or automatic feed.
Equipment pay back in months	This is the variable projection of the return on investment according to which equipment purchased cost will provide the actual gain in the time after use.
Manual handling and insertion time	This is the variable which defines the time related to the manual handling and insertion of assembly operation.
Maximum feed rate	This variable defines the rate with which the feed is progressed.
Number of shifts	This variable defines the number of the shifts which are used for system in operation.
Rate of assembly worker	This is the wage rate which is assumed for the assembly worker.
Time spend on number of shift	This variable defines the total time which is consumed for completion of the production targets in number of the shifts.

Table 4.20 Base Case Variables for Case Study # 4.10

Seri al No	Parameter definition and unit value
1	<i>Average manual assembly time per part = $T_{AVMAsS}=8$, units in seconds per part</i>
2	<i>Average station cycle time = $T_{AVC}=8$, given units of seconds</i>
3	<i>Capital investment = $C_{AP INV}=7000$, given units of dollars</i>
4	<i>Cost of magazine = $C_{MAXine}=1000$, given units of dollars</i>
5	<i>Equipment over head ratio = $E_{qOver-Head}=2$, given units of DMNL consider 100%</i>
6	<i>Feeder cost = $F_{EED-COST}=30*100000$, given units of cents</i>
7	<i>Equipment pay back in months = $E_{qPAY-BACK}=18$, units of Second</i>
8	<i>Manual handling insertion time = $T_{HANDLING-INSERTION}=2$, given units in cents</i>
9	<i>Max feed rate = $R_{MAX-FEED}=10$, given units of parts/minutes</i>
10	<i>Number of shifts = $N_{SHIFT}=2$, given units of DMNL</i>

11	Rate of the assembly worker= $R_{ASS-WORKER}=8$, given units of dollars/seconds
12	Time spend in no of shift= $T_{SPEND-SHIFT}=864000$, given units of Second

Let us consider for the model the facts that firstly we take the

Initial time

$$T_i = 0$$

Final time

$$T_f = 10$$

Units =Year

Time Step:

$$\Delta T = 0.125$$

Any instant T:

$$T = \sum_i^n 0.125 \times n + T_i \dots \dots \dots (4.29)$$

Where $n = \frac{T_f - T_i}{\Delta T}$

We have the following nomenclature for evaluating this average manual assembly time per part= $T_{AVMASS}=8$ sec , with given units in seconds per part @ T_i

Average station cycle time= $T_{AVC}= 8$ sec, with given units of seconds@ time T_i

Capital investment= $C_{AP INV}=7000$ dollars, with given units of dollars @time T_i

Cost of the magazine= $C_{MAXine}=1000$ dollars, with given units of dollars @time T_i

Equipment over head ratio= $E_{qOver-Head}=2$, with given units of DMNL @time T_i

Equipment pay back = $E_{qPAY-BACK}=18$ months, with given units of months @time T_i

Feeder cost= $F_{EED-COST}=30*100000$ cents, with given units of cents@ time T_i

Manual handling insertion time= $T_{HANDLING-INSERTION}=2$, with units of cents @time T_i

Max feed rate= $R_{MAX-FEED}=10$ parts/minutes, with given units of parts/minuts @time T_i

Number of Shifts= $N_{SHIFT}=2$, with given units of DMNL considering shifts @time T_i

Rate of the assembly worker= $R_{ASS-WORKER}=8$,with given units of cents/Seconds @time T_i

Time Spend in number of shift= $T_{SPEND-SHIFT}=864000$, given units in seconds @time T_i

considering 8 hr shift for 30 days Feed equipment rate= $R_{FEED-EQUIP}$

Total cost of assembly worker= $C_{ASS-WORKER}$

Total cost of manually loaded magazine= $C_{MAN-LOAD-MAXINE}$

Total auto-feeding cost= $C_{AUTO-FEEDING}$

Now in order to have the feed equipment rate= $R_{FEED-EQUIP}$ at the final time T_f with and in the units of cents/second is given in Equation (4.30) as such:

$$R_{FEED - EQUIP}(T_f) = \int_{T_i}^{T_f} [(EqOver - Head \times F_{EED - COST}) \times 1 / T_{SPEND - SHIFT} \times S_{Mfg - Total} \times EqPAY - BACK] * dT + R_{FEED - EQUIP}(T_i) \dots \dots \dots (4.30)$$

Now in order to have total cost of manually loaded magazine= $C_{MAN-LOAD-MAXINE}$ at the final time T_f with and in the units of Cents/Seconds is obtained by Equation (4.31) as such:

$$C_{MAN - LOAD - MAXINE}(T_f) = \int_{T_i}^{T_f} [(C_{MAXINE} + R_{ASS - WORKER} / N_{SHIFT} + C_{AP - INF}) \times T_{AVCycle} + R_{ASS - WORKER}T + T_{AVM - ASS}] * dT + C_{MAN - LOAD - MAXINE}(T_i) \dots \dots \dots (4.31)$$

Now in order to have total cost of assembly worker= $C_{ASS-WORKER}$ at the final time T_f with and in the units of cents/seconds is represented by Equation (4.32) as such:

$$C_{ASS - WORKER}(T_f) = \int_{T_i}^{T_f} [(C_{MAN - LOADED - MAXINE}) + (T_{HANDLING - INSERTION})] * dT + C_{ASS - WORKER}(T_i) \dots \dots \dots (4.32)$$

Now in order to have total auto-feeding cost= $C_{AUTO-FEEDING}$ at the final time T_f with and in the units of Cents/second and Equation (4.33) formulated as such:

$$C_{AUTO - FEEDING}(T_f) = \int_{T_i}^{T_f} (R_{FEED - EQUIP} + R_{MAX - FEED}) \times dT + C_{AUTO - FEEDING}(T_i) \dots \dots \dots (4.33)$$

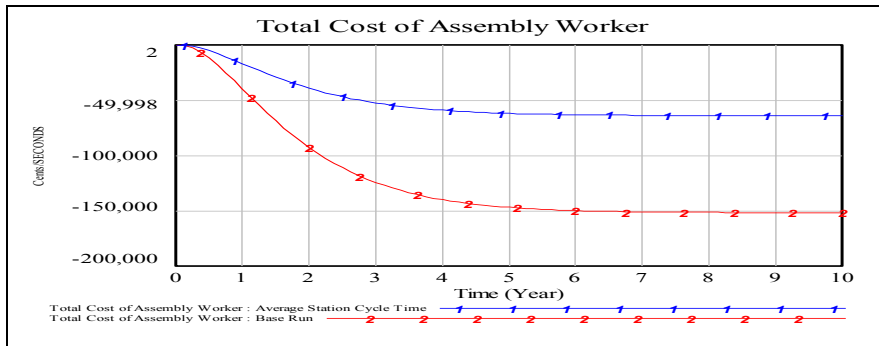

Figure 4.81 Total Cost of Assembly Workers.

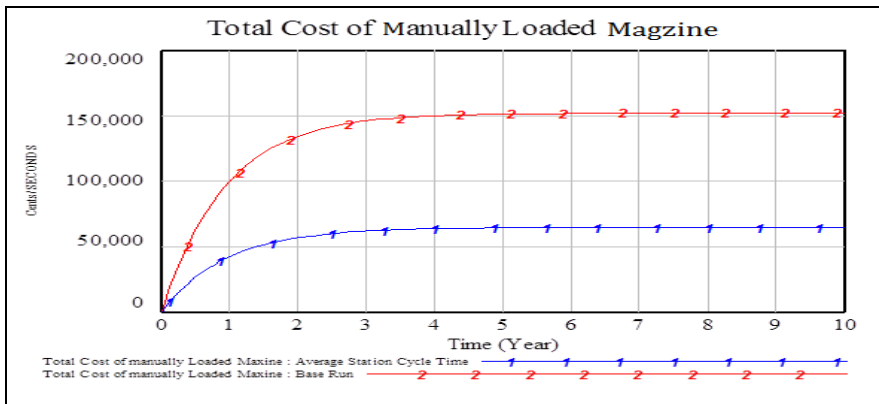

Figure 4.82 Total Cost of Manually Loaded Magazine

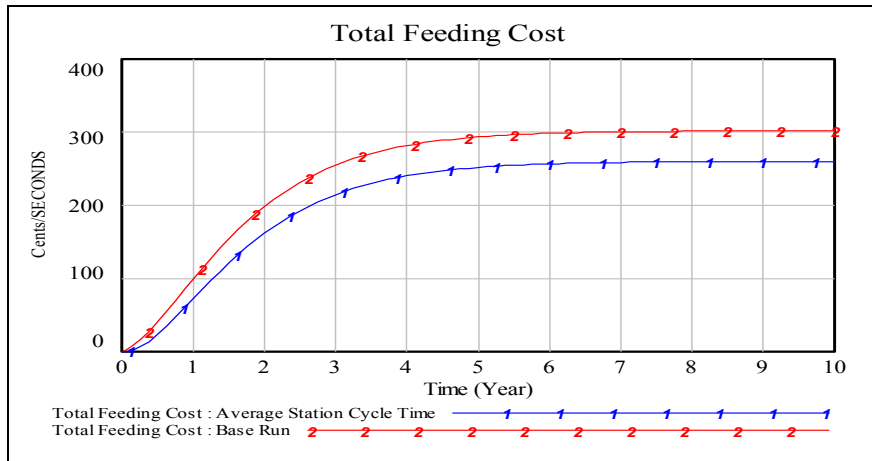

Figure 4.83 Total Automatic Feeding Cost

Figure 4.81 reflects the total cost of assembly worker shown while Figure 4.82. show the cost of manually loaded magazine and Figure (4.83) shows the total automatic cost. Base run reflects that total cost of assembly worker can be controlled if we minimize the labour cost then we will face low yield as low number of people will be on the line.

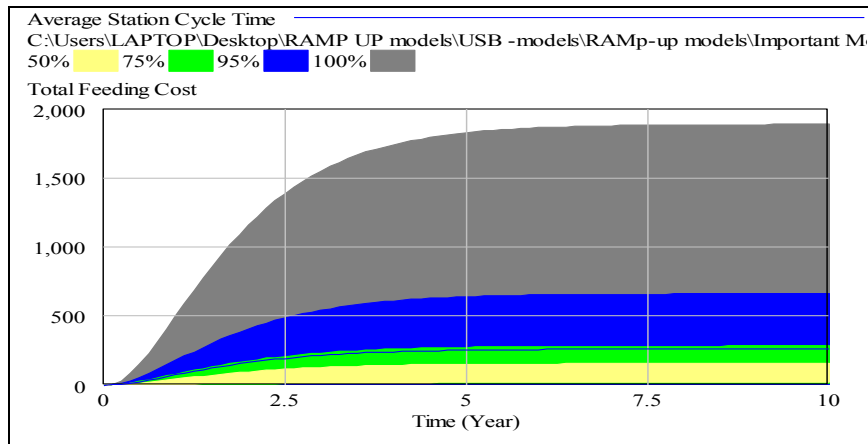

Figure 4.84 Total Feeding Cost Multivariate Simulation

as evident explicitly the fact shown in Figure 4.84 that the curve beyond 95% shows the human element which shows the curve shadow grey area for achieving the goal as planned due to automation while cost due to human element is visible if automation is avoided. Less number of people off course for manageable low variety and low volumes. Next, it is argued on the face of it that automation is the decisive factor in reaching this goal seeking behavior of the system, accordingly. Similarly, Figure 4.85 highlights the Individual traces of the of the fluctuation in total feed cost obviously due to the fact that fluctuation in volumes and economy of scale and scope, agility factor with production mix is dominated by improving the cycle time and markets dynamics to satisfy demand.

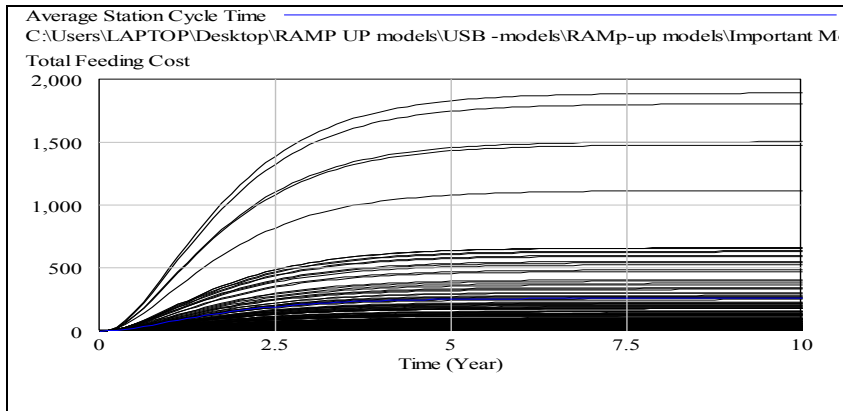

Figure 4.85 Total Feeding Cost Individual Traces

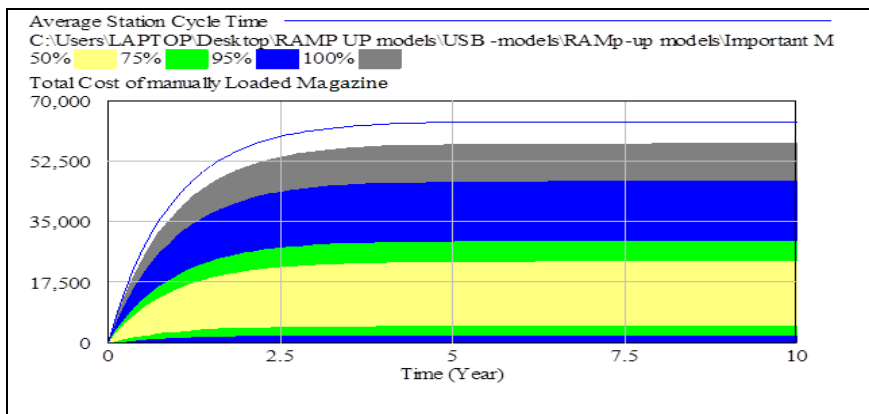

Figure 4.86 Total Cost of Manually Loaded Magazine Multivariate Simulation.

Where as to have a competitive edge more value addition through customization and personalization in product portfolio is necessary. Hence, automation is indeed the jugular vein of entire manufacturing system. Average station cycle time as we see that the parameters when changed then visible behavior shows the decay behavior pattern in system which is having units of cents per seconds in the form of logistic decay. Similarly, from the figure 4.86 total cost of manually loaded magazine is also having the root in the average station cycle time. Lastly, Figure 4.88 shows the result of the simulation as such that automatic feed cost is observed as it behaves differently in terms of magnitude where as the change in the parameter of the maximum feed rate is having domination in a sense that any perturbation can result on similar behavior with different intensity of magnitude in the form of logistic growth. This would result similar behavior with different intensity of magnitude in the form of the logistic growth. Sensitivity analysis shows the multivariate and individual traces from Figures 4.87 shows total cost of manually loaded magazine individual traces where the cost factor fluctuates due to cycle time similarly

when cycle time is improve with given random variable limits 95% percentile show the result in the Figure 4.88 and individual traces in Figure 4.89 as cycle time improves and fluctuates.

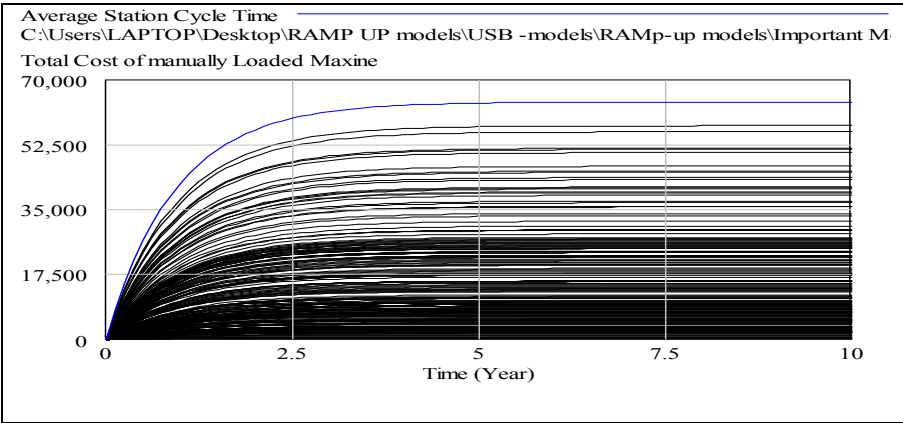

Figure 4.87 Total Cost of Manually Loaded Magazine Individual traces.

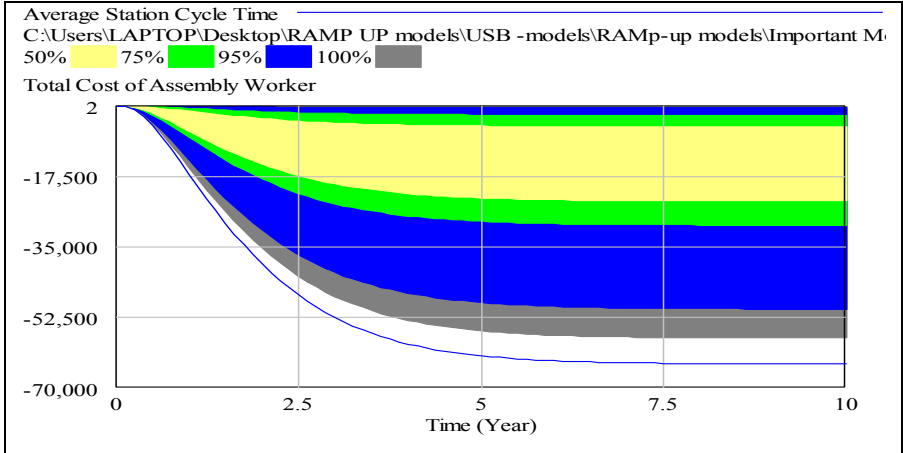

Figure 4.88 Total Cost of Assembly Worker Multivariate Sensitivity.

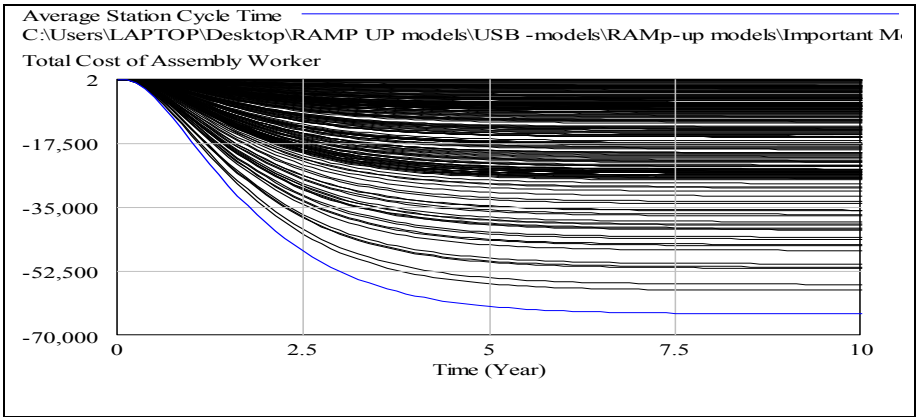

Figure 4.89 Total Cost of Assembly Worker Individual Traces.

CHAPTER V

SOCIO-TECHNICAL SYSTEM RISK ASSESMENT AND EQUILIBRIAM IMPACT A TRIPLE BOTTOM LINE ANALYSIS

5.1 Introduction

The focus of sustainable design at the system level has a multi focused approach. Besides the compliance with regulations this involves social & product particular technical aspect along with the aspiration of the customer. Similarly, considering the sociotechnical environmental system development imperative for industrial system sustainability it is observed that this process is dominated by focusing on attributes and functions and their respective system level inter relations which must be reflected in the product development process. System level design focuses on an approach which is based on a holistic view of product development. In order to achieve a sustainable green economy, we need to have an effective sustainable system based on technical, social and environmental system level product performance assessment approach. In this chapter, a risk analysis approach, based on triple bottom line sustainability factor index, is presented using Utility functions.

5.2 System Level Attribute Representation and Assessment Tool

The concept of the triple bottom line in product development system got its importance when the regulations were enforced by many governments for the benefit of the stakeholders involved in industrial production. An important consideration is the energy cost. Recall the state of the world resources under the oil embargo of the 1970s. In this context, the need for alternative energy sources have been emphasized by academia and as well as by industry. The concern over the world's global warming and depleting resources mark the beginning of seriousness of the climate change and sociotechnical system and its ecological focus to be more economical and sustainable for future generation. Therefore, a weighted function, through using utility of attribute for each factor in each product is required. After the calculation of individual contribution, the overall value of sustainability can be calculated. Later it could be possible to alter the design to optimize the value into desired range of values e.g. replacing one material to another or an optimal value can be obtained by increasing the reusability of its components. Therefore, on the basis of the different characteristics and their relevant attributes, if we consider the available data of different sets of the product with their

attributes and try to construct a mathematical model, then one of the simplified methods is described by Hyman (1998) as such if we construct a utility function then the process of determining the utility function can be broken into five steps:

- (1) Introducing terminology and ideas,
- (2) Determining the general preference structure,
- (3) Assessing single-attribute utility functions,
- (4) Evaluating scaling constants, and
- (5) Checking for consistency and reiterating.

For decision problems with a single objective, only Steps 1, 3, and 5 are relevant. In practice, there is considerable interaction between the steps although mathematically; suppose some characteristic value or utility is given by a function according to Figure 5.1 and $u=0$ when $s=0$, therefore $u=1$ when if and only if $s=1$ and for each choice of the parameter r , there will be a different curve within a family of curves.

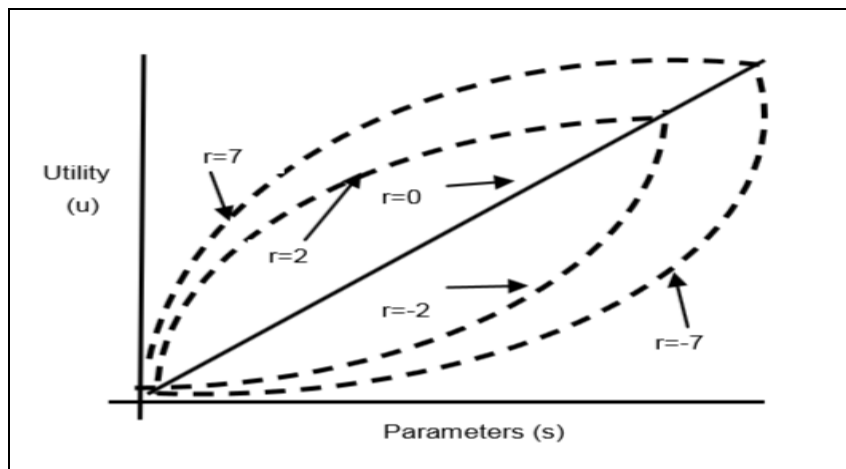

Figure 5.1 Family of Utility Function.(after Heyman (1998))

$r=0$, $r=-2$, $r=-7$, $r=2$, $r=7$, Utility (u) and Parameters (s); The straight line utility function occurs when $r=0$. as described by Heyman (1998) From Figure 5.1:

$r > 0$ (The utility function represents a risk averse behavior)

$r < 0$ (The utility function represents a risk prone behavior)

$r = 0$ (The utility function represents a straight line risk neutral behavior)

The least desirable of an outcome of a utility of curves While the most desirable out come in a given decision has a utility of 1 $u(1)$; $U(M)=1$, where utility of (M) is the value of any behavior under focus of study, the simplification of utility function model for $r=0$ is

described as equation of utility function will be developed as such The equation of utility function will be

$$u(s) = \frac{1-e^{-rs}}{1-e^{-r}} \dots\dots\dots(5.1)$$

therefore u(s) is turn out to be equation of the straight line when r=0, but when we set in the above equation then

$$u(s) = \frac{0}{0} \dots\dots\dots (5.2)$$

which can be resolved by using the L'Hopital's rule to get

$$u(s) = \lim_{r \rightarrow 0} \frac{d/dr 1-e^{-rs}}{d/dr 1-e^{-r}} \dots\dots\dots(5.3)$$

this yield to the equation of straight line as such

$$u(s)_{r \rightarrow 0} = \lim \left[\frac{se^{-rs}}{se^r} \right] \dots\dots\dots(5.4)$$

5.3 Implementation & Case Study

The equation of the straight line equation (5.4) can provide a linear scale i.e. by means of adopting this method or using linear interpolation data can be quantified for the given attributes and comparative analysis can be made to form a prototype case study. In this context, a system based theoretical model has been described above in general. Now let us consider a new product of hybrid electric car or Electric or Gas as alternative1, 2, and 3, respectively. We have assumed every parameter we want to represent the sustainability based upon very basic requirement. If we elaborate on, it further on the basis of environment, economics and social aspects of sustainability then we have to consider following using 80/20 analysis as explained by Armstrong (2006). Now, what minimum factors are having significant impact. The numbers given in all the tables are choices of the designer's. However, experience is important for analysis of all aspects which can

enables the designer to produce variety of analysis by considering different attributes as we discuss the significance of this in the following section.

5.4 Environmental Engineering Aspects

Focusing the product in terms of the primary important aspect which is important for the stakeholders which includes the state and world body and also the customer and entrepreneur. The significant factors for our new product can be summarized as such that it involves the green house gas (GHG) emission, natural resources consumption, maximum break horse power (BHP) available and battery management. The current design features intends to reduce the environmental burden and therefore, there will be less green house gas emissions. So the international and national standard for green house gas reduction will eventually be met. There will be less use of the natural resources like the oil and therefore less oil will be consumed from the natural sources. Therefore, oil for the coming generation natural resource depletion will be less. Apart from that material used should be reusable after re-engineering or parts could be interchangeable and recyclable hence will in turn save the natural resource consumption. The prime mover will be having less frictional losses and therefore more BHP will be available in comparison with the internal combustion engine where thermal efficiency of the plant is higher than the BHP produced. The complexity of the battery management energy storage, etc. needs to be understood fully with regard to reusability, recyclability and interchangeability into similar product variety, etc. which gives the life cycle picture of the product. Thus, we have the utility values shown in Table 5.1 for the product with regards to environmental and engineering aspects.

5.5 Engineering Economic Aspects

In this section, we focus on the product from very important perspective of customer as well as the manufacturer. Both are looking for the cost reducing possibilities in order to make the product economically viable. The significant factors are: the initial cost, low fuel consumption, maintenance and repair, market affordability, etc. Thus the initial cost of hybrid or the electric cars are considerably higher than the available internal combustion engine type cars. But in the long run, due to the uncertainty in the oil price

Table 5.1 General Environmental Focus

Desired Environmental Engineering Aspects			
Parameter	Alternative-1 (Hybrid)	Alternative -2 (Electric)	Alternative-3 (Gas)
GHG emission	0.5	0.25	1.0
Natural resources used	0.5	0.25	1.0
BHP available	0.5	0.25	1.0
Battery management	0.5	1.0	0.25

being taxed at the pump it has a significant effect. The hybrid and the plug-in will be using much less fuel while electric will use no fuel. Therefore, competitive product price should be reasonable and affordable in today’s global economy. In this regard government regulations to help buy new electric and hybrid cars are also an attempt to establish a market which is helpful. Inter changeability of the various parts among different variety of the same product is very essential just like vehicle tires if of the same size can fit any brand name of cars. This creates an affordable pool of product market for affordability. Thus we have the utility values shown in Table 5.2 for product in focus of economic and engineering aspects desired perspective.

Table 5.2 General Economics Focus

Desired Engineering Economics Aspects			
Parameter	Alternative-1 (Hybrid)	Alternative -2 (Electric)	Alternative-3 (Gas)
GHG emission	1.0	1.0	0.5
Natural resources used	0.25	0.25	1.0
BHP available	1.0	1.0	0.5
Battery management	1.0	1.0	0.5

5.6 Social Engineering Aspects

The social engineering aspect is important for new designed products as this is the parameter that gauges the trends and general behavior patterns of the market as well as the customer identified need and versatility. This is achieved through this aspect and social networking can ease the process. However, focusing our case study; it has been observed that new technology, product life cycle, purpose of use and interior spacing of the vehicle are important considerations. The need for change and acceptance may have different set of powerful drivers and motivators but the significance of this aspect is important. For every new technology introduced through the new product design it will take time to make its place in the market. Therefore, it will take time to establish a social mind set of the public to choose plug-ins or hybrid for car purchase, etc. These kinds of expected products can not satisfy the quest of heavy duty use of one's investment as it is a question that if the maximum carrying load capacity increases this will affect the acceleration of the vehicle which is an undesirable fact. Similarly, the highway use of the vehicle has not proven yet and it can be risky for longer and continuous journey. Apart from this the vehicle spacing due to the very big size of the battery is minimized as the area and the load is now occupied by the battery. After getting the values of each factor, it is obvious that all of the factors are not of equal value e.g. emission of carbon monoxide or emission of ammonia cannot be of same weight. Thus, we have the utility values shown in the Table 5.3 for product in focus from social engineering aspects desired perspective.

Table 5.3 General Social Engineering Focus

Desired Engineering Economics Aspects			
Parameter	Alternative-1 (Hybrid)	Alternative -2 (Electric)	Alternative-3 (Gas)
New technology	1.0	1.0	0.5
Product life cycle	1.0	0.5	0.5
Purpose of use	1.0	1.0	0.5
Vehicle interior spacing	0.5	0.5	1.0

5.7 Results and Analysis

If we consider the maximum value as our best choice and minimum is our worst choices then we have the following aggregate as shown in table 5.4 below. Table 5.4 Shows comparison of alternatives. From Table 5.4, we observe that the best choice we have by having the highest grand aggregate value of alternative 3, which has the highest overall total numbers, but while pondering the numbers on the right hand column we observed that their attribute values from equilibrium point of view are not sustainable as such that

Table 5.4 Over all Parameter and Alternative for Analysis

No	Parameter	Alternate-1	Alternate-2	Alternate-3	Sub-Total	Total
1	Desired environmental and engineering aspect	0.5	10	0	10.5	42
		0.5	10	0	10.5	
		0.5	0	10	10.5	
		0.5	0	10	10.5	
2	Desired economic engineering Aspects	0	0	10	10	70
		10	10	0	20	
		0	0	10	10	
		0	0	10	10	
		10	10	0	20	
3	Desired Social Engineering Aspect	0	0	0.5	0.5	42.5
		10	10	0.5	10	
		10	10	0.5	20.5	
		0.5	0.5	10	20	
Grand Total		65	60	75		

for as such that for instance the attribute value is showing the dominating characteristics of economical aspect. However, which is related or not directly associated with the social and environmental aspects. Therefore, social capital values and environmental capital

values of related attributes are to be assessed more carefully in order to bring this type of product in the market. Table 5.4 gives us a description with respect to triple bottom line perspective and hence shows the significant factors of sustainability which are more influencing the decision maker. Table 5.4 also shows the significance of those attributes which would contribute the most influencing factor of the economic aspect for all available alternatives. Consider the analogy of the equilibrium condition of a physical system where as a body in this context is said to be in the state of the stable equilibrium if, on being slightly disturbed, it tends to return to its original position; unstable if it tends to go over further, and neutral if it will remain at rest in differently in any position. The law of triangle of forces as described by Duncan (2010) can be, applied here; then accordingly.

Let us consider what condition must be satisfied in order that 3 forces acting at the same point must balance one another. In this context let us suppose that there are 3 forces of some magnitude X, Y and Z acting at point A. It is assumed that one of them must be equal and opposite to the resultant of the other two. Consider by extended the concept further into a parallelogram of forces the resultant of the X, Y, Z and R must be equal and opposite. Resolving the forces in to a parallelogram we have as such: $X:Y:Z = X:Y:R = AB:AD:CA$ If we take the components as such $R = Z$ and $AD = BC$, then: $X:Y:Z = AB:BC:CA$ If we take the components as such: $R = Z$ and $AD = BC$ then $X:Y:Z = AB:BC:CA$ which are the 3 given forces proportional to the sides of the triangle ΔABC . Now the equilibrium of the forces X,Y,Z drawn as the proportional sides of the triangle as shown in Figure 5.2.

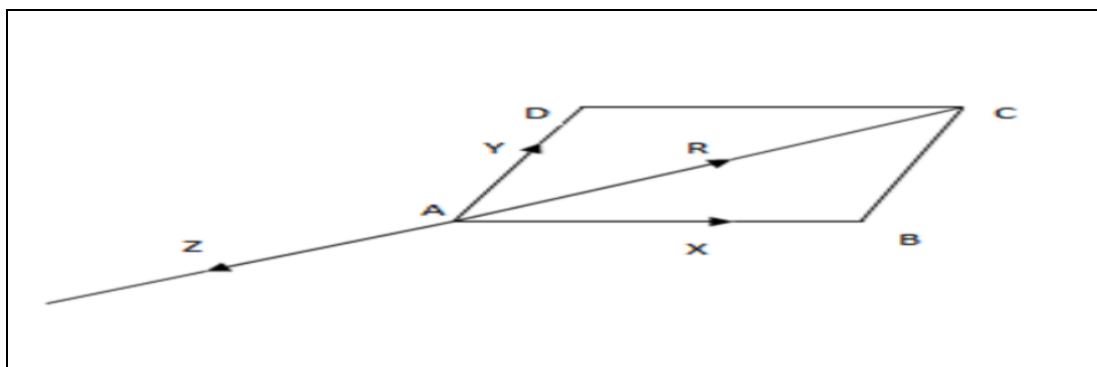

Figure 5.2 Forces acting on a Point

Therefore, in the triangle ΔABC ; $AC = R = Z$, $AB = X$, and $BC = AD = Y$. Therefore, if the lines are drawn so to give a closed triangle then the given forces will be in equilibrium. The triangle ABC is called the triangle of forces for the given forces X, Y, Z , as shown in Figure 5.3. Now resolving the aggregate value into forces and applying law of forces at single point to balance the triangle of forces as such to get the single point for balancing the actions as such a scale according to the force strength have been adopted as:

$$AB=70=70.0 \text{ cm}, BC=42=42.0 \text{ cm}, AC=42.5=42.5 \text{ cm}$$

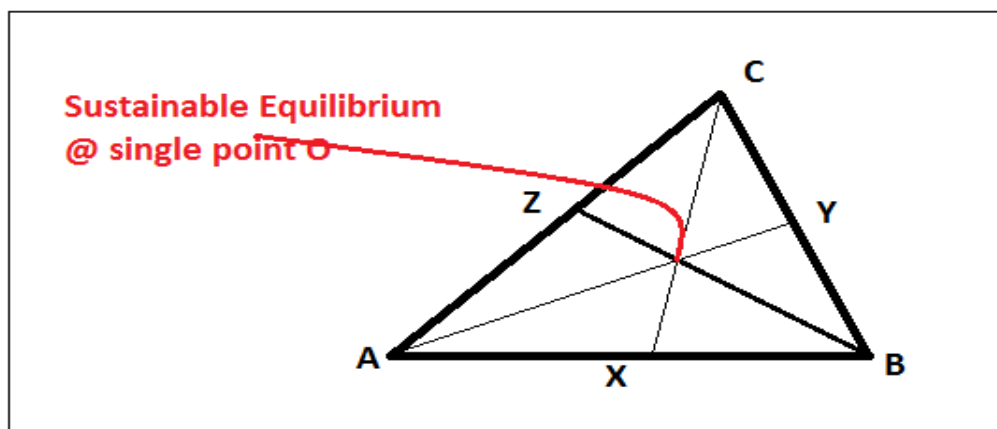

Figure 5.3 Equilibrium in Centroid (after Ali-Qureshi et al. (2011)) as per Appendix G

In this context, we take measurement from the midpoint to the side of the triangle. Then, Where does the center of gravity exists? We know that we have to have that much amount of acting force in order to get an equilibrium balance which will satisfy the law of triangular of forces Duncan (2010), in order to achieve single point equilibrium at the centroid. As shown in Figure 5.3 above, where three lines are generated as the sides of triangle and they are intersecting each other at the same point O which is called the point of concurrency. If we measured distance in our study in focus when drawn approximately produces the distance $OZ = 1.7 \text{ cm}$. and $OY = 1.5 \text{ cm}$. and $OX = 1.0 \text{ cm}$. Then this distance from the centimeters scale can be translated to the relevant scale of the force value of corresponding amount. Which is the amount of force required to achieve single point equilibrium for sustaining the condition of equilibrium. This is then required to adjust the assessment in accordance to the parameter set for getting the balance of sustainable equilibrium. This sustainable equilibrium is necessary in order to save the resources

environment and economic capital for all stake holders of society. This also forms an Impact factor index defined in equation (5.5) as such:

$$Impact\ factor = \frac{Desired\ impct\ Value}{Actual\ Impact\ Value} \dots \dots \dots (5.5)$$

Therefore, the impact factor index can be found by the above formula as given in Equation (5.5) above and this can be used for further analysis with re-assessed value gained from measuring the significance of the impact. This shows us that the higher the index, the higher the potential for the impact as shown in Table 5.5 below, where drawn values are approximately measured and translated in to equal force value. The index factors shows the potential and significance of impact on the system as a whole and described the fact that it can minimize the cost and this will produce affect in the market economy for potential growth with compromise to the relative quality which translate the unstable condition attribute. So for making the system analysis for large system, the index factor can be used to have the increased magnitude or decrease as the case may fit for analysis.

Table 5.5 Impact Factor Index For Environmental and Engineering

Environmental & Engineering Impact Factor Index	Economic Engineering Impact Factor Index	Social Engineering Impact Factor Index
$\frac{BC}{OY} = \frac{42}{15} = 2.8$	$\frac{AB}{OX} = \frac{70}{10} = 7$	$\frac{AC}{OZ} = \frac{42.5}{17} = 2.5$

CHAPTER VI

SOCIAL AND PSYCHOLOGICAL ASPECT OF TECHNICAL MANAGEMENT: A NEW PARADIGM IN SOCIO TECHNICAL SYSTEM DESIGN

As a matter of fact for efficient personnel planning with complex learning processes and knowledge transfer with product change, it is vital to identify and measure the complexity indices of human behavior including psychology. Thus, in this chapter the dynamic simulation models of sociotechnical are proposed. Therefore, different important psychological aspects are discussed in the various sections of this chapter.

6.1 *Perspective on Personality and Behavior*

Although Lester et al. (2008) defined behaviorism in great length. However, there are still dissatisfactions among psychologists with behaviorism who objected to restricting the subject matter of psychology to overt behavior. Some believe it can be expanded to encompass all facets of human potential. However, cognitive and mental processes cannot be omitted. Today, behaviorists are beginning to study a wider range of human behavior, including mental phenomena such as decision making and maladjustment.

6.2 *Motivation Theory*

The concept of motivation is that it is a kind of a way to encourage yourself and others to action purposefully to achieve the goal. Both the external factors as well as inner state of mind can increase the desire to work in a person. Identification of internal motives, are usually considered only for business clients and management purposes in the corporate environment, not in the manufacturing systems. Therefore, it is proposed that human needs and dynamic changes in the motives of manufacturing team should also be analyzed using the following well-known theories. In this regard the fundamental work exist in length and breadth of the issue but the more relevant to our focus are mentioned herein as such ; Porter and Lawler, (1968), Schwab and Cummings, (1970), Hackman and Oldham, (1976) and Baard, Deci, and Ryan (2004). Following are the major Theories of Motivation which are as such:

1. Maslow's Need Hierarchy Theory
2. Herzberg's Motiva I Jon-Hygiene Theory

3. McGregor's Theory X and Theory Y
4. Theory Z
5. Alderfer's ERG Theory
6. Vroom's Expectancy Theory
7. Porter-Lawler Model of Motivation

6.3 Porter-Lawler Model of Motivation:

The Porter and Lawler model explains that an individual's motivation to complete a task is affected by the reward they expect to receive for completing the task. The Porter-Lawler expectancy model is a model of work motivation. It is an extension of an earlier expectancy model developed by Vroom (1964). A person will decide to behave or act in a certain way because of what they expect will be the outcome. Therefore, reward is the basis of increasing human performance as shown in Figure 6.1. Rewards are both intrinsic such as positive feelings and satisfaction and extrinsic rewards such as money and promotion. Performance leads to intrinsic as well as extrinsic rewards depending on fairness. However, the intrinsic rewards are long-lasting and produce attitudes about satisfaction that are related to performance. The motivation is also affected by the individual's ability to perform the task and their perception of the role activities and behaviors that the person feels they should be engaged into to do the performance

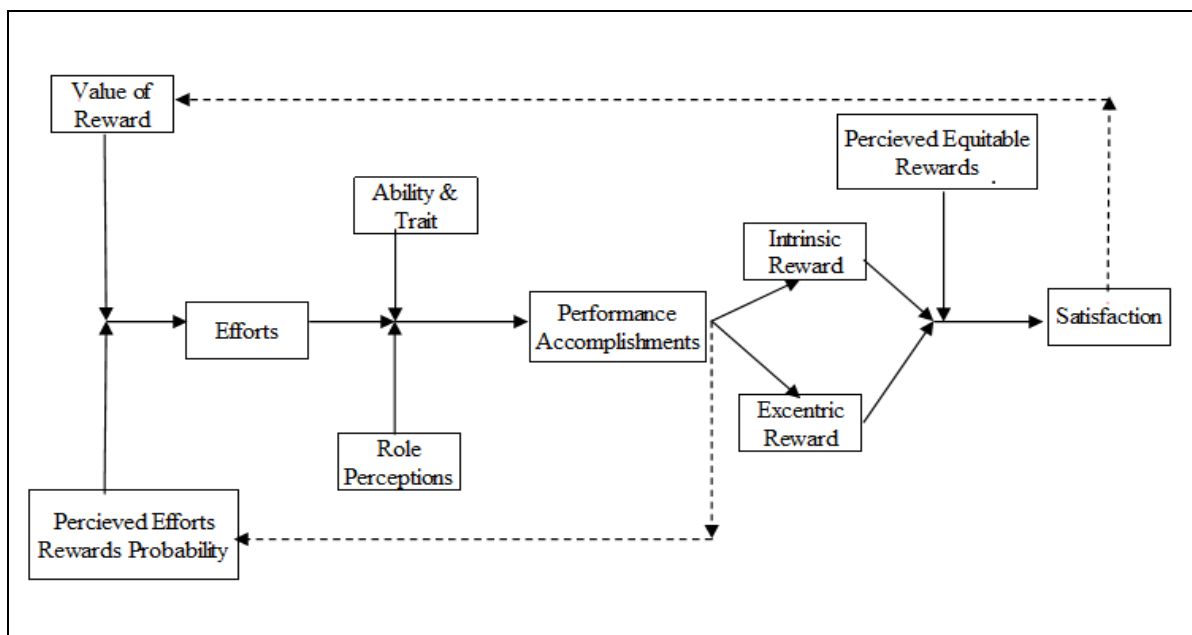

Figure 6.1 Porter & Lawler Motivation Model (after Porter et al. (1968))

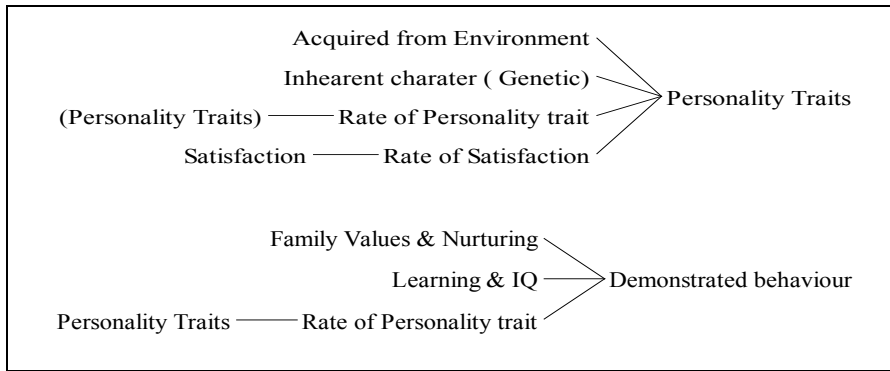

Figure 6.2 Key Relations and Attributes of Porter & Lawler Motivation Re-model

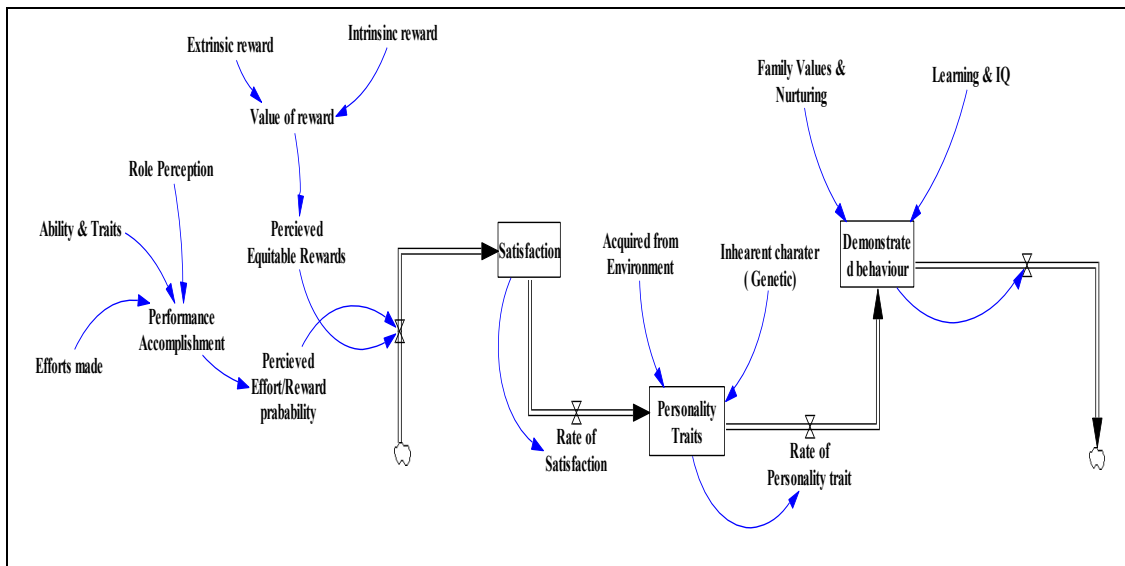

Figure 6.3 Re-modeling of Motivation for Performance

successfully. Therefore, Porter-Lawler theory of motivation is adopted to develop the proposed dynamic model to identify the human behavior complexities. Lastly, satisfaction is derived to the extent where actual rewards fall short to meet or exceed the individual's perceived level of equitable rewards. If actual rewards meet or exceed perceived equitable rewards, the individual will feel satisfied; if these are less than equitable rewards, he will be dissatisfied as described by Porter-Lawler. The work expectancy model based on Porter-Lawler's motivation theory is comprehensive and multivariate with simple traditional assumptions focusing primarily on managers to explain the complex relationship that exists between job attitudes and job performance has generated a considerable amount of research and debate. In this dissertation, the proposed model differs not only in focusing on non-managerial manufacturing positions but also altered many traditional assumptions such as adopting non-linearity in system dynamics. Figure

6.2 shows the key relations and Figure 6.3 shows the new model which depicts these differences. Therefore, a motivation model is being sketched for analysis of the theory in its new perspective. The model description, the equations and parameters of Case Study # 6.1 is presented ahead as such.

Case Study # 6.1

In this context we first model the equations and parameters and variables which will help shape the modeling simulation and results for this purpose all variables are defined in the Table 6.1 where as the parameter definition and their respective value are defined and shown in Table 6.2 of this case study.

Initial time

$$T_i = 0$$

Final time

$$T_f = 4 \text{ Minutes}$$

Time Step:

$$dt = 0.125$$

Units=Week

Any instant T:

$$T = \sum_i^n 0.125 \times n + T_i \dots\dots\dots(6.1)$$

Where $n = \frac{T_f - T_i}{\Delta T}$

Table 6.1 Variable name and Definitions for Case Study # 6.1

Variable Name	Variable Definition
Acquired from environment	This is the variable which defines the acquired knowledge from the environment from which the homo sapiens is exposed to perform some task. This can be referred as learner behaviour.
Ability and traits	This variable defines the ability to cope the task and inclination of the traits.
Family values & nurturing	This variable defines the family values and nurturing tendencies in a personality
Efforts made	This variable defines the actual level of efforts which are made in the context of completion of task.
Extrinsic reward	This variable defines the tangible rewards which are visible to others for instance bonuses to employee, holiday packages cruise tour vacations
Intrinsic reward	This variable defines the rewards which are in tangible as such a comment or compliment.

Role perception	
Demonstrated behavior	This is the variable which is concerned for the actual behaviour which is demonstrated by the individual.
Personality traits	This is the variable which defines the general personality traits
Rate of personality traits	This is the variable which defines the rate of the personality traits with which the individual is composed of.
Inherent character (Genetic)	This is the variable which defines the inherent genetic mental make of an individual homosapian. It is partly donated in genes of the human parents in terms of race and gender.
Rate of satisfaction	This is the variable with which the human labour as individual is satisfied.
Learning & IQ	This is the variable which defines the behaviour of learning and IQ which is acquired intelligence from practice or exposed to the experience develops certain learning area and intelligent quotient
Satisfaction	This is the variable which defines the overall satisfaction state of the system.
Perceived effort/reward probability	This is the variable which is core in the motivation as the labour perceives that there is chance to win the reward provided that efforts are made in this direction therefore, more the input from the labour comes then more probability is to win a reward this perception keeps the labour motivated.
Perceived equitable rewards	This is the variable which defines the perception of the labour to understand the value of the reward if intrinsic and /or extrinsic.
Value of reward	This is the variable which defines the extrinsic and intrinsic rewards with tangible and in tangible value;
Performance accomplishment	This is the variable which defines the performance related to the accomplishment made or accomplishments achieved.

Table 6.2 Base Case Variables for Case Study #6.1

Serial #	Parameter definition and unit value
1	Acquired from environment= $A_{CQ-ENVIRON}= 50\%$, with units of DMNL.
2	Ability and traits= $A_{B-TRAIT}=1$, with the units of DMNL
3	Family values & nurturing= $F_{AM-V-NUR}=1$, with the units of DMNL
4	Efforts made= $E_{FF-MADE}=1$, with the units of DMNL
5	Extrinsic reward= $E_{XT-REW}=1$,with the units of DMNL
6	Intrinsic reward= $I_{NT-REW}=10$, with the units of DMNL
7	Role perception = $R_{OL-PERCP}=1$, with the units of DMNL
8	Demonstrated behavior = $D_{EMO-BEHAV}$
9	Personality traits= $P_{ER-TRAIT}$
10	Rate of personality trait= $R_{PER-TRAIT}$

11	Inherent character (Genetic) = $I_{CHR-GENE}$
12	Rate of satisfaction= R_{SAT}
13	Learning & IQ= L_{RN-IQ}
14	Satisfaction= SAT
15	Perceived effort/reward probability = $P_{ER-EFF-REW-PROB}$
16	Perceived equitable rewards= $P_{ER-EQT-REW}$
17	Value of Reward= V_{AL-REW}
18	Performance Accomplishment= $P_{ER-ACOMP}$

Where acquired from environment= $A_{CQ-ENVIRON} = 50%$, at T_i and the units of DMNL

Where ability and traits= $A_{B-TRAIT} = 1$, with initial time T_i and the units of DMNL

Where family values & nurturing= $F_{AM-V-NUR} = 1$, with initial of time T_i and units of DMNL

Where efforts made= $E_{FF-MADE} = 1$, with initial time T_i and the units of DMNL

Where extrinsic reward= $E_{XT-REW} = 1$, with initial time T_i and the units of DMNL

Where intrinsic reward= $I_{NT-REW} = 10$, with initial time T_i and the units of DMNL

Where role perception = $R_{OL-PERCP} = 1$, with initial time T_i and the units of DMNL

Where demonstrated behavior = $D_{EMO-BEHAV}$

Where personality traits= $P_{ER-TRAIT}$

Where rate of personality trait= $R_{PER-TRAIT}$

Where inherent character (Genetic) = $I_{CHR-GENE}$

Where rate of satisfaction= R_{SAT}

Where learning & IQ= L_{RN-IQ}

Where Satisfaction= SAT

Where perceived effort/reward probability = $P_{ER-EFF-REW-PROB}$

Where perceived equitable rewards= $P_{ER-EQT-REW}$

Now in order to have the Value of Reward at the initial time T_i and given units of dimension less (DMNL), we have mathematical relation as defined in Equation 6.2:

(Value of reward) $V_{AL-REW} = (\text{Extrinsic reward}) E_{XT-REW} + (\text{Intrinsic reward}) I_{NT-REW}$

$$V_{AL-REW} = E_{XT-REW} + I_{NT-REW} \dots\dots\dots (6.2)$$

whereas where value of reward= V_{AL-REW} and extrinsic reward= E_{XT-REW} and also intrinsic reward= I_{NT-REW}

Similarly in order to determine the Performance Accomplishment at initial time T_i and with the given units of DMNL we have mathematical relation as shown in Equation 6.3:

(Performance Accomplishment) $P_{ER-ACOMP} =$ (Ability and Traits) $A_{B-TRAIT} +$ (Efforts made) $E_{FF-MADE} +$ (Role perception) $R_{OL-PERCP}$

$$P_{ER-ACOMP} = A_{B-TRAIT} + E_{FF-MADE} + R_{OL-PERCP} \dots \dots \dots (6.3)$$

Now in order to have the Perceived Effort/Reward probability at the initial time T_i and given units of DMNL we have mathematical relation as shown in Equation 6.4:

(Perceived Effort/Reward probability) $P_{ER-EFF-REW-PROB} =$ (Performance Accomplishment) $P_{ER-ACOMP}$

$$P_{ER-EFF-REW-PROB} = P_{ER-ACOMP} \dots \dots \dots (6.4)$$

whereas perceived effort/reward probability $= P_{ER-EFF-REW-PROB}$ and where performance accomplishment $= P_{ER-ACOMP}$

Similarly in order to determine the equitable rewards at the initial time T_i and with the given units of DMNL, we have mathematical relation as shown in Equation 6.5:

(Perceived Equitable Rewards) $P_{ER-EQT-REW} =$ Value of reward Value of Reward $= V_{AL-REW}$

$$P_{ER-EQT-REW} = V_{AL-REW} \dots \dots \dots (6.5)$$

where perceived equitable rewards $= P_{ER-EQT-REW}$ and where we have value of reward as V_{AL-REW}

Now in order to have the Rate of Personality trait at the initial time T_i and given units of DMNL we have mathematical relation as shown in Equation 6.6:

(Rate of Personality trait) $R_{PER-TRAIT} =$ (Personality Traits) $P_{ER-TRAIT}$

$$R_{PER-TRAIT} = P_{ER-TRAIT} \dots \dots \dots (6.6)$$

whereas rate of personality trait $= R_{PER-TRAIT}$ and where personality traits $= P_{ER-TRAIT}$

Besides in order to have the Rate of Satisfaction at the initial time T_i and given units of DMNL we have mathematical relation as defined in Equation 6.7:

(Rate of Satisfaction) $R_{SAT} =$ (Satisfaction) SAT

$$R_{SAT} = SAT \dots \dots \dots (6.7)$$

whereas the rate of satisfaction $= R_{SAT}$ and where satisfaction is abbreviated as SAT

In order to determine the demonstrated personality of a subject at the final time T_f and the given units of DMNL, to understand a general phenomenon we have mathematical relation as defined in Equation 6.8 :

$$DEMO - BEHAV(T_f) = \int_{T_i}^{T_f} [(F_{AM - VAL - NUR} + L_{RN - IQ}) \times R_{PER - TRAIT}] \times dT + DEMO - BEHAV(T_i) \dots \dots \dots (6.8)$$

In order to determine the Personality Traits of a subject at the final time T_f and the given units of DMNL to understand a general phenomenon we have mathematical relation as define in Equation 6.9 :

$$PER - TRAIT(T_f) = \int_{T_i}^{T_f} [(A_{CQ - ENVIRON} + I_{CHR - GENE}) \times R_{SAT}] \times dT + PER - TRAIT(T_i) \dots \dots \dots (6.9)$$

The satisfaction of a subject is determined at the final time T_f and the given units of DMNL to understand a general phenomenon by the mathematical relation as defined in Equation 6.10:

$$SAT(T_f) = \int_{T_i}^{T_f} [(P_{ER - EFF - REW - PROB} + P_{ER - EQT - REW}) - R_{SAT}] \times dT + SAT(T_i) \dots \dots \dots (6.10)$$

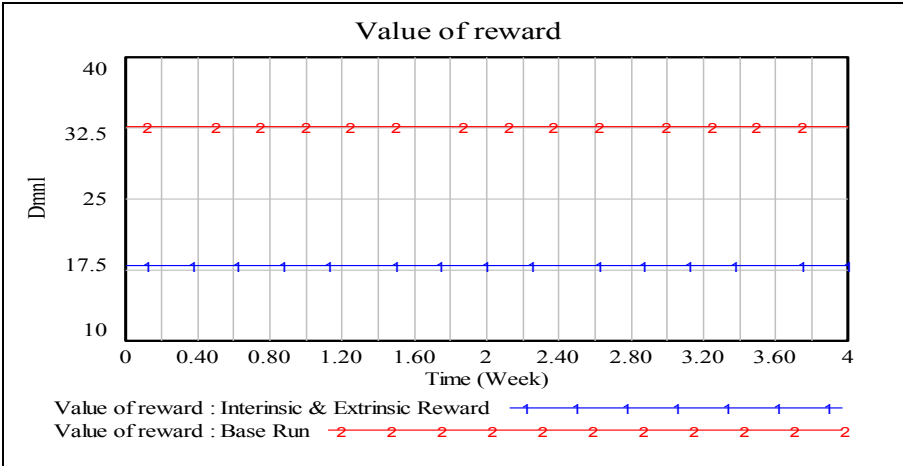

Figure 6.4 Value of Reward.

In this context simulation result describes the fact that the value of the reward is for the base run is having higher value while the same is perturbed and brought to the lower level say about 17 points from about 32 points as shown in Figure 6.4 and there is significant

change in the behaviour as shown in Figure 6.5 where exponential growth steady curve seems falling in to the lowest level which is quite understandable.

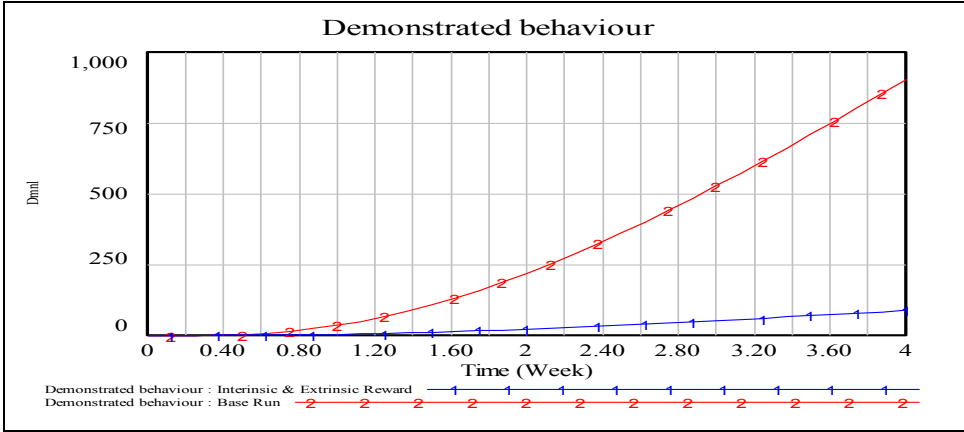

Figure 6.5 Demonstrated Behaviour.



Figure 6.6 Satisfaction Level.

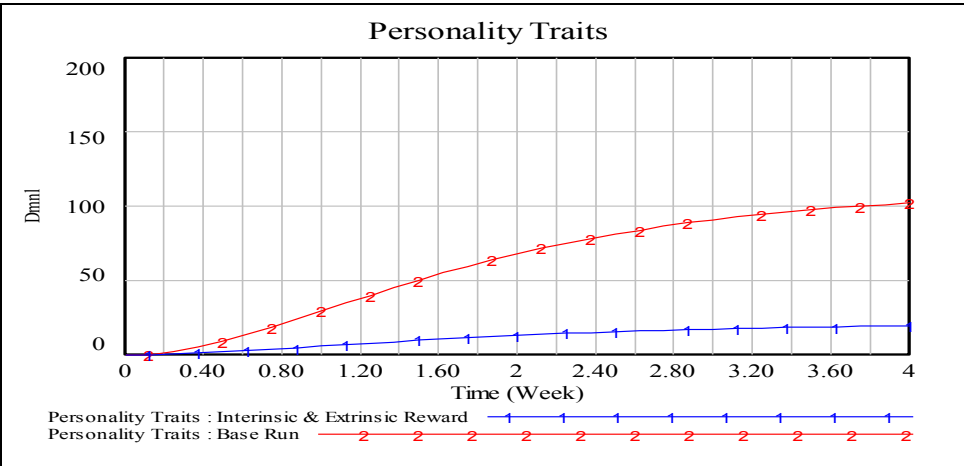

Figure 6.7 Personality Traits

From Figure 6.6 it has been observed that the level of satisfaction has also been disturbed and now base run (red line) which has potential exponential growth fall to significantly

visible lower level as it can be seen in Figure 6.6. Figure 6.7 depicts the low exhibits of the trait or a drop in full swing personality of enthusiastic nature in to a less interested one as such an empathic administration is telling some person in between the lines the as he is an odd man out. The behavior of s shape growth is dropped suddenly into exponential growth with small growth level.

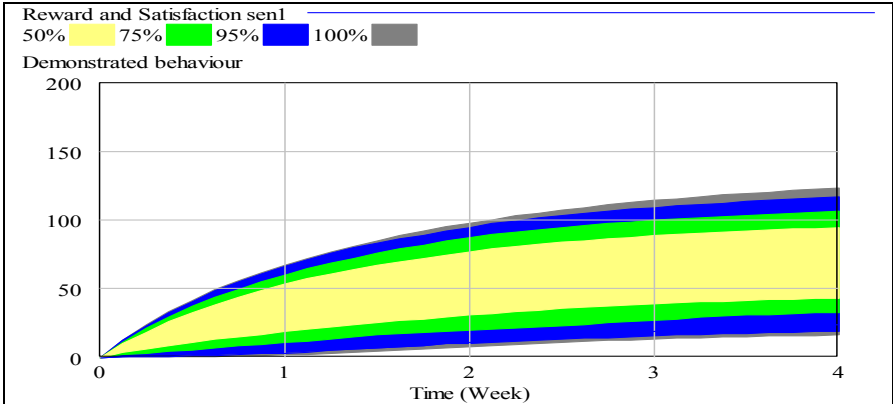

Figure 6.8 Multivariate Sensitivity of Reward and Satisfaction

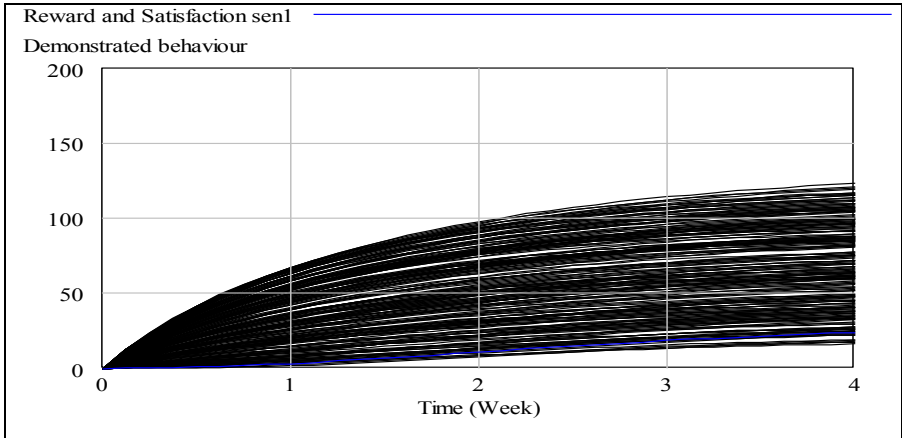

Figure 6.9 Individual Traces of Demonstrated Behavior.

From Figure 6.8 the initial base run state of the system shows the intrinsic rewards are at the highest point where as perceived equitable rewards as shown in Figure 6.9 in the same system another genetic and environment variable is perturbed to observe the system over all. Similarly, the sensitivity of multivariate and individual traces are shown in Figure 6.8 and 6.9 respectively, which validates the model along with discrete event simulation give us whole system picture pertaining to Level variable under focus.

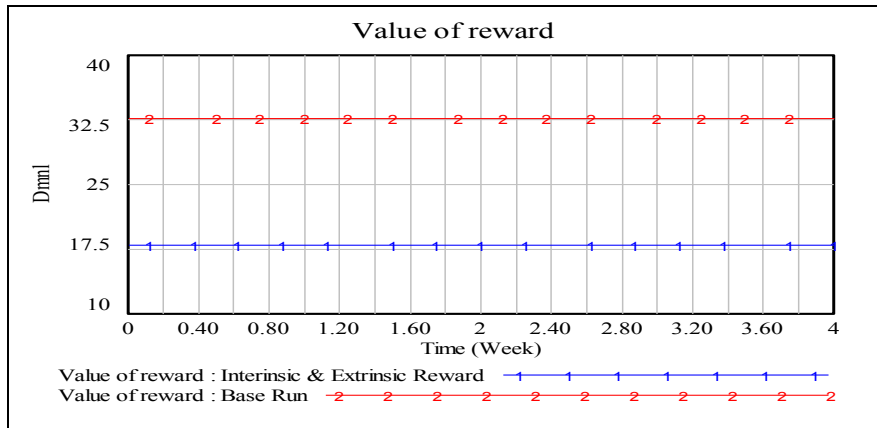

Figure 6.10 Original Value of Reward.

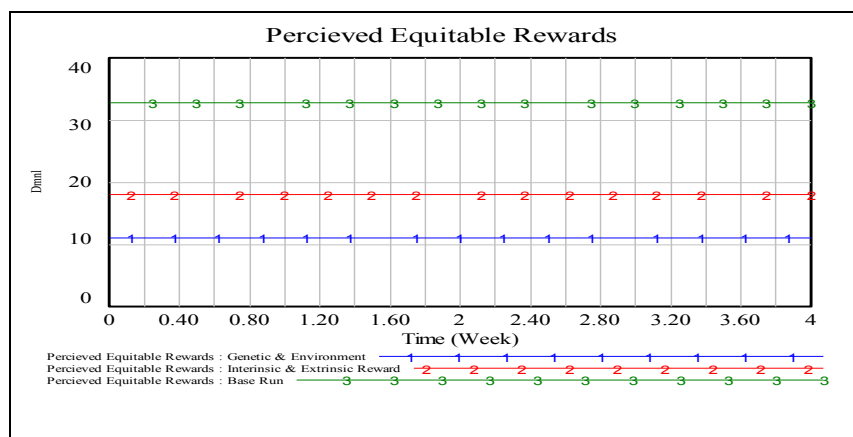

Figure 6.11 Perceived Rewards

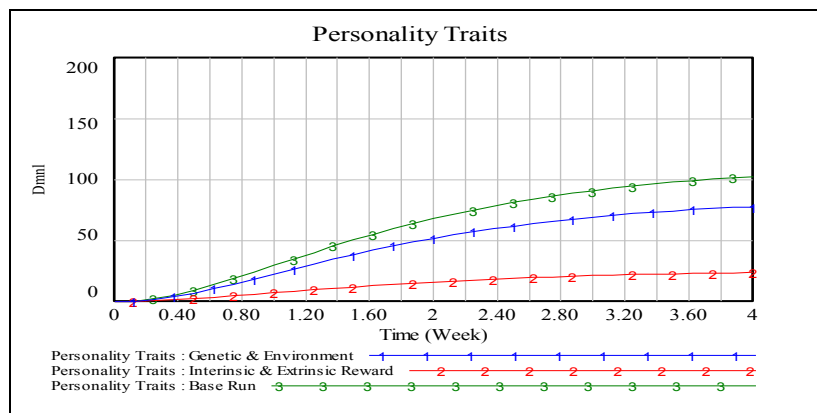

Figure 6.12 Personality Traits.

From Figure 6.10 the initial base run state of the system shows the intrinsic rewards are at the highest point where as perceived equitable rewards as shown in Figure 6.11 in the same system another genetic and environment is perturbed to observe the system over all. The figure shows the linear behavior which means no abrupt change.

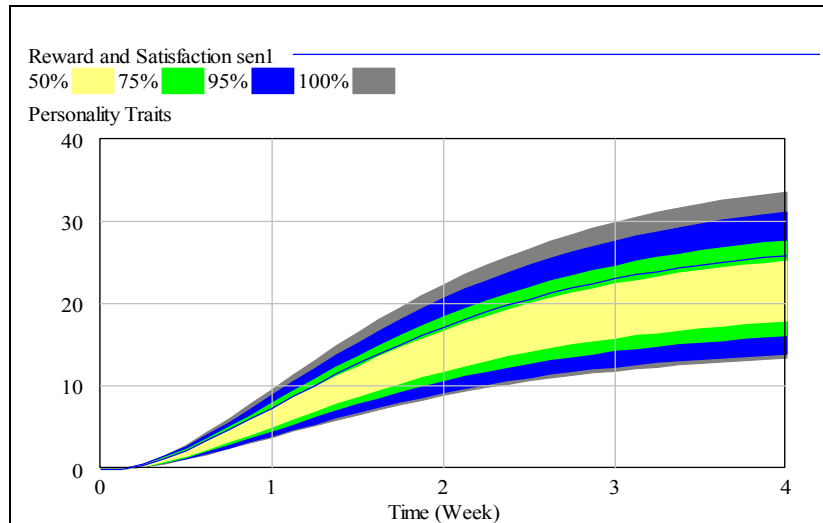

Figure 6.13 Multivariate Sensitivity of Satisfaction Personality Trait Focus

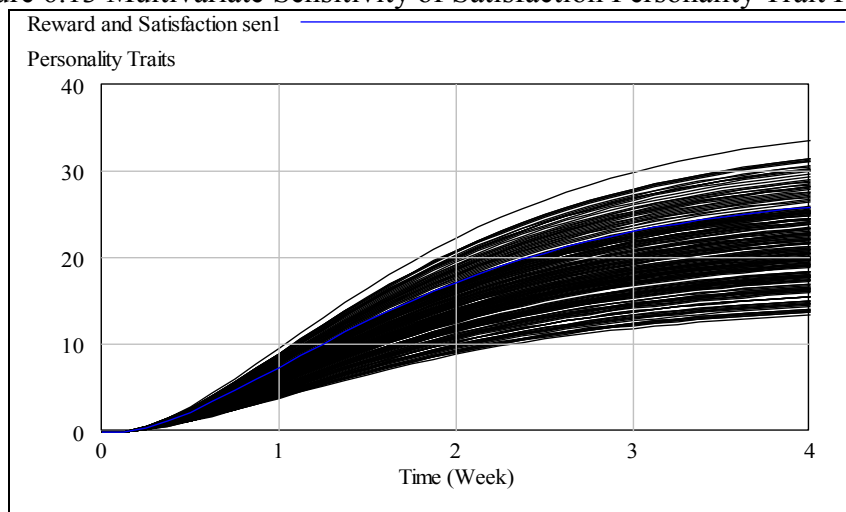

Figure 6.14 Reward and Satisfaction Individual Traces

In this context it has been observed that similar behavior pattern in personality traits with a significant change that from our base case; the intrinsic perturbation of reward do affect the personality traits but in the second case when the genetic and environment has been also changed then significant change occurred in the personality trait as shown in Figure 6.12 which shows the impact of the attribute of genetic and environment in the system over all behavior. The behavior of the curve seems to be S-curve as it does not seem to be exponential growth. While the Figures 6.13 and 6.14 shows the multivariate and individual traces of reward and satisfaction pertaining to personality traits.

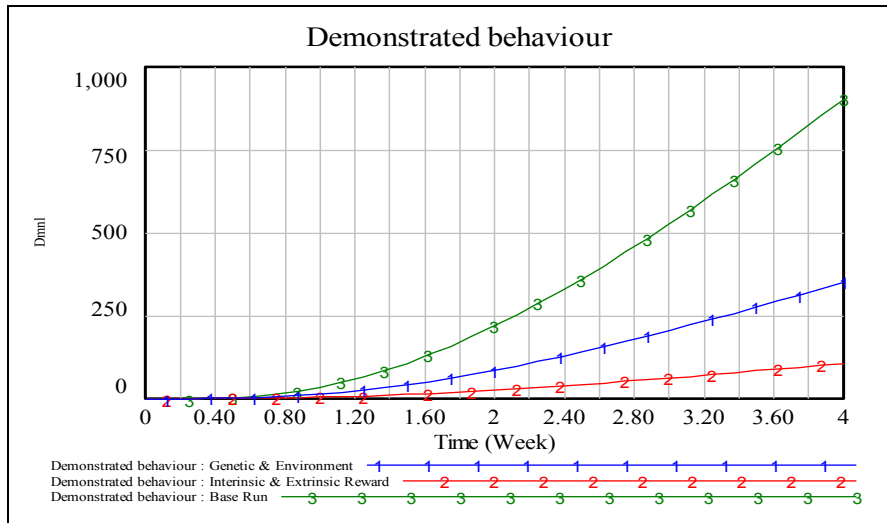

Figure 6.15 Demonstrated Behavior

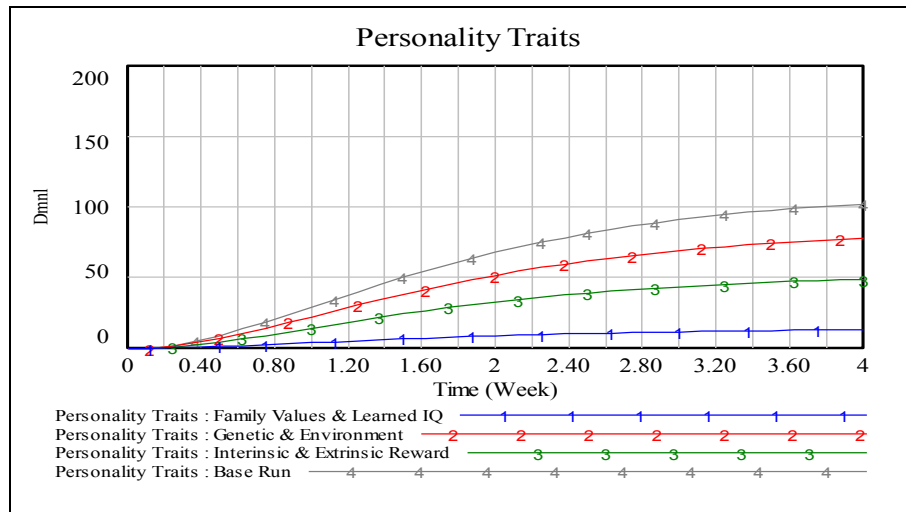

Figure 6.16 Personality Traits.

Similarly, from Figure 6.15 that base run demonstrated behavior is affected and a sudden drop in the magnitude is quite visible which describes similar pattern of behavior though. Ordinarily, the system has exhibited the fact that the exponential growth is changed dropping due to a visible genetic and environmental perturbation in the system. Now the simulation result describes the fact that from Figure 6.16 personality traits has very significant effect as the blue line on the graph explains this phenomena as its pattern for all of our cases in which we have had focused in our previous case studies. Its significance is quite limited therefore the impact of the attribute is very vital in the system which means it needed to be handled with special care.

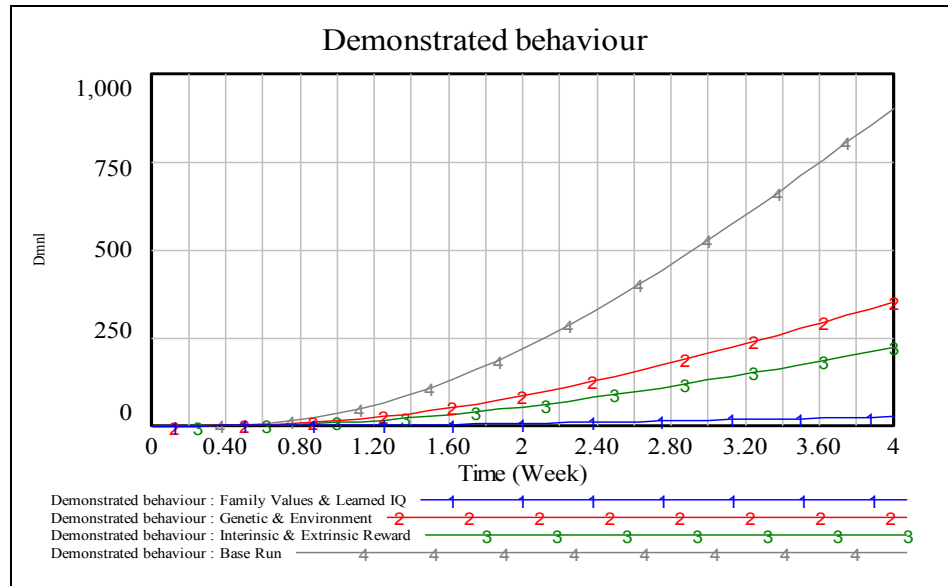

Figure 6.17 Demonstrated Behavior

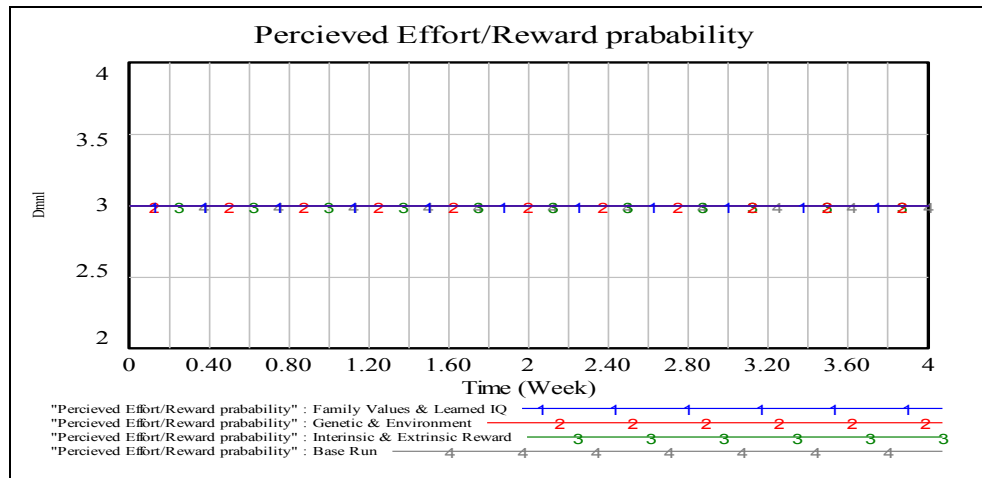

Figure 6.18 Perceived Effort and Reward Probability.

Figure 6.17 shows that the demonstrated behavior is almost none while touching the base line approaching zero. Which reflects that the fall from the base run which is due to the perturbation incurred in the important attribute of family values and learned IQ? The result of the simulation as depicted in Figure 6.18 describes that the perceived effort and reward probability has no perturbation effect while the linear line shows the same.

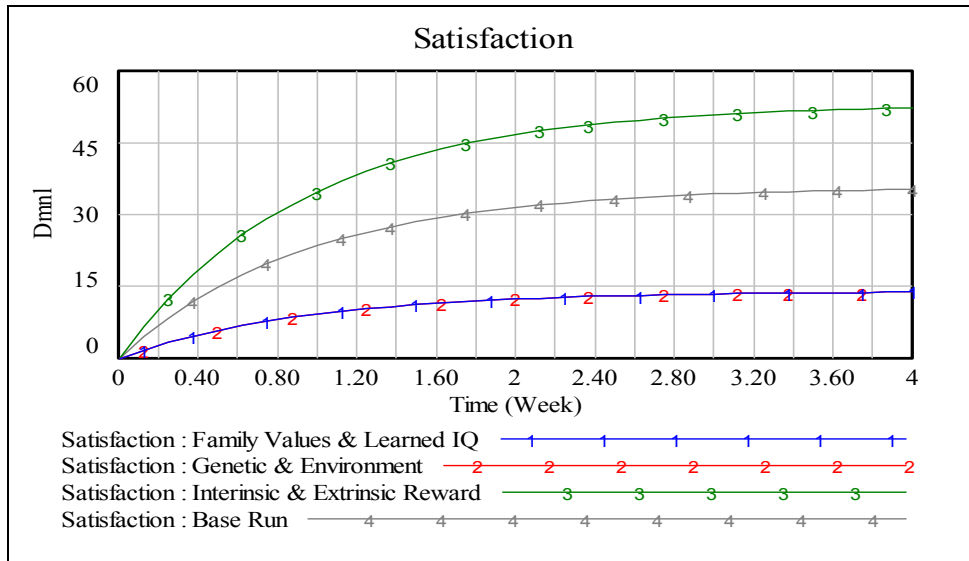

Figure 6.19 Satisfaction Level

behavior pattern for all of our cases in which we have had focused in our previous case studies. This means that for all the cases, the expectations are the same however behavior change occurs when different parameters are changed in the system. Therefore, from Figure 6.18 visible shift is witnessed between the family values and learned IQ and genetic and environment influence. Significance of the result is that this is an indication of the fact that there exist a very dominant role of the aforementioned attributes in the satisfaction and in our motivation model.

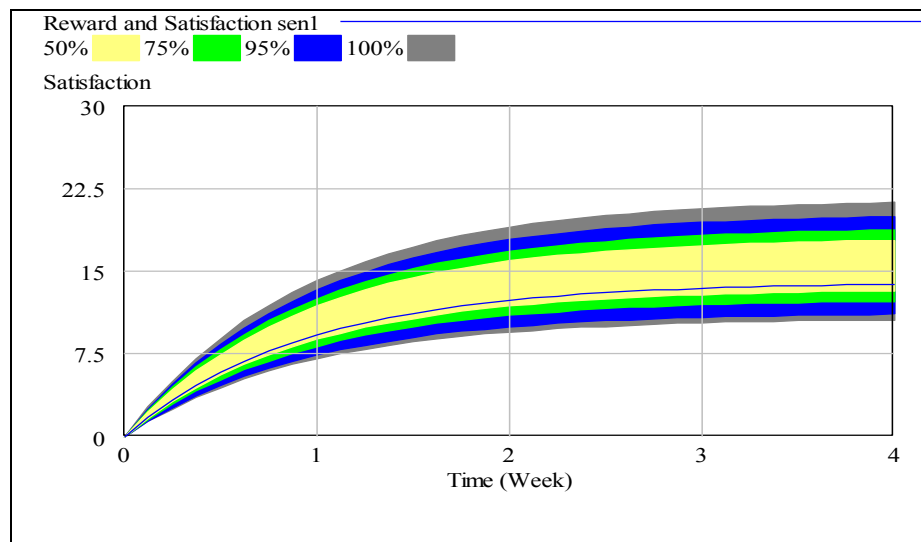

Figure 6.20 Multivariate Sensitivity of Reward and Satisfaction.

If intrinsic and extrinsic reward is kept high in the system variable then the satisfaction curve shows the maximum magnitude from our base case run which is lower as shown in Figure 6.19 in terms of satisfaction. While the aforesaid attributes have the same impact besides the exponential growth behavior in general is persistent and perturbation in any factor will not change this behavior. Next, Figures 6.20 and 6.21 show the multivariate sensitivity analysis and individual traces which are quite explicit in validating the model behavior in about 240 runs, for judging the reward and satisfaction perturbation in multi and its individual traces for understanding.

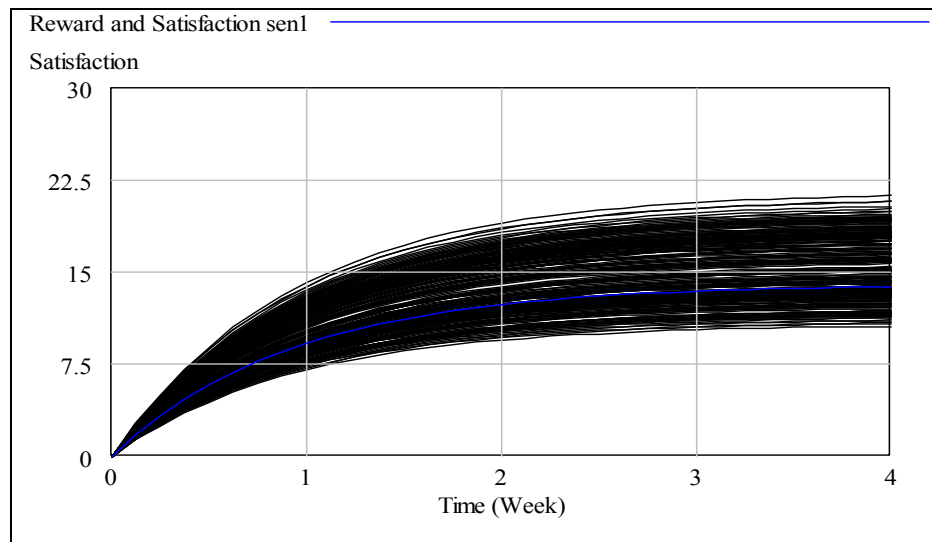

Figure 6.21 Sensitivity Analysis of Reward and Satisfaction Individual Traces.

CHAPTER VII

SUMMARY AND CONCLUSIONS

Effective ramp up is the key for keeping the competitive edge in the free market economy. The customer preferences create the new markets which fluctuate and compel the manufacturer to have mix production and variety. Continuous improvement in the product features, variety, pricing and quality keeps the nonstop ramp-up one way or the other in the manufacturing firms. In today's automated manufacturing, the installation, planning and scheduling of production equipment, and the strategies for coping with variety, involves the reliance on and integration of hard and soft enablers. Besides the core compatibility issues like logical and physical automated systems development, from various programmable logical controllers (PLCs) such as by Allen Bradley or Siemens controls, to Lab View and other computer aided design (CAD) and computer aided manufacturing (CAM) software, the manufacturing system is complex and continuously evolving. With that background, this research focuses on and presents non-linear system dynamic based models of systems and sub-systems of the complex manufacturing systems including the continuous ramp-up processes involved. Complexity indices are suggested that help in not only producing accurate products, in precise quantities owing to lean production paradigm, but also within the minimum limits of estimated timeline to reach the customer, just in-time (JIT). The models have also incorporated contributing sociotechnical factors to explore the impact of the ramp-up processes within the targeted quality and cycle-times. The research was conducted in the form of several diverse and complementary case studies covering many typical stages and aspects of manufacturing system design where the impact on ramp-up process becomes significant e.g. assembly complexity in process and in design. Endogenous variables lie within the boundary of a model where the structure and policies within the modeled system influence the variables' behavior. While exogenous variables lie outside the model boundary that have no causal connection from the endogenous variables within the model boundary but have causal connections to the endogenous variables in the model. Ideally, exogenous variables remain constant throughout the time horizon of the model. For analysis of the intrinsic or independent variable which can individually influence to change the dependent variable and so as the system behavior because of its inherent property or characteristic embedded

as elements of the system under study. The extrinsic or dependent variable is the one whose value affects the behavior of the system but that is due to the influencing character of the random variables of non-dependent variables in the system, whose study is in focus. Next, for Monte Carlo simulation for the sensitivity analysis it is assumed that the simulation run for 200 times and the noise seed value to be 1234. These numbers are kept constant throughout the analysis for consistency in the results. With that in mind, following are the summary of the results.

In this context, the first Case Study # 4.1, focuses on the following system scenario for study as such that the system present capacity holds a linear curve on the base run for products per year, as constant value, therefore, when system with 2 million products each year with average cost of 15 thousand per product is in present capacity produced but when the in order to achieve the target of 6 million the system needed to be upgraded to target the annual usage and RAS cost which are two independent and an intrinsic variable parameter and hence, random variable in the case study. But the rate of the carrying cost which is doubled in resulting curve show the incurring changed value in the system. Next, the sensitivity analysis shows the fact that the random distribution is presenting a curve and steady linear ramp after an inflow with no increase any further. The distribution shows that within the first year the significant growth and then constant magnitude allows the distribution stay constant for the extrinsic or depending level variable of the EOQ. Although, the random variable parameters when perturbed from lower bound to the upper bound in the sensitivity analysis of Monte Carlo simulation result shows the range of the 75% is achievable in the first year or so and remained saturated with null significance change in behavior. The level variable distribution is spread from 0-10 years instead 0-5 years just to give a big view over larger period of time. In Case Study # 4.2, it is observed, from the system exhibited facts, what number of reliable machines will be required to accomplish the task or producing a similar family of parts. When the independent parameters are randomly perturbed to the upper bound during the Monte Carlo simulation for sensitivity analysis then the distribution shows us the fact that increasing the number of parts more machinery will be required with reliability of availability for completing the task, which is an extrinsic variable. As the analysis is

spread 0-100 time units, on the horizontal axis, which shows that steady growth from very beginning and this phenomenon is continuous as the random generation of individual traces shows us as well as such that at 25 units of time we require 4.5 machines while 50 units of time we need about 6 machines and ratio increasing with passage of time. Here the level variable number of machine required depends upon the parameter of independent variables which influences the behavior of the system. The resulting distribution is negative exponential with the balancing loop which is the goal seeking behavior of the system. Case Study # 4.3 model displays the behavior of the system when the EOQ (Economic Order Quantity) is increased by maximizing the daily demand order the significance change have occurred and the system shows that the less than 50 to more than 100 products per week will increased. Now the finished goods to the customer show a steady delivery trend of goods with obvious increase of in the independent variable of the cost per order. Extrinsic variable provides the fact that lower and upper bound increasing or decreasing EOQ is similar and achievable with in less than 5 weeks or so, while later the random variable uniform distribution show saturation with no further increase in system behavior. The random variable seems to less influencing in the system as the curve becomes exponentially distributed. Therefore, in order to increase the capability and capacity new policy needed to be introduced with new intrinsic variables. In Case Study # 4.4, when daily demand is perturbed, then the EOQ changes from the 165 products per week to about two hundred products per week, and so as the daily with holding cost increases from 340 to 495 dollars/week. Distribution projects the curve indicates that about 0-3 weeks the saturation occurs and there is no more further increase except it becomes stable, provided for the variable parameter remains within same random limit which was intrinsic to the system. The Monte Carlo simulation run suggests that for the given random variables the system behavior is same which validates the model and alongside depicts that lower bound and upper bound random variables projects the distribution in early couple of week or so say 5 week or something where as the 75% to 95% variation can occur accordingly in nearly all Level variables resulting in goal seek behavior showing negative exponential growth. Similarly, in Case Study # 4.5 similar, the behavior pattern is observed with exception of the fact that the random variables of the intrinsic value independent variable influences all level variables of the system which

includes the level variable of total with holding cost, total cost of all parts exhibits the same behavior pattern in Monte Carlo simulation runs for sensitivity analysis are completed. But the only noticeable pattern is in the Total Shipment cost, which is increasing the individual and multivariate sensitivity shows the fact as well. Whereas the daily demand random variable changes, 95 % occurs starting in the mid couple of weeks and then progress gradually and so as the total cost level variable. The comparative cost analysis of the manual and automatic machine feed for assembly suggests that in all the involved cost oriented scenarios, the expenses occurred on the machine tools are reasonably higher with the fast change in technology invites further cost implications. However, the fact is manual labour has its own repercussions involving sociotechnical behaviour which affects the labour performance. The distribution resulting forms a goal seek behaviour with negative exponential growth. The research result give us better picture of the DFA and DFM by using the system dynamic modeling and sensitivity of multivariate and individual traces dictates the decision maker to look through the whole system. In Case Study # 4.6, the intrinsic variables of total number of parts, number of sub-assembly components and ratio of affords made along with DFA variable exhibits the goal seek behavior of negative exponential growth. As it is observed from the Monte Carlo simulation as well that the independent variables are influential with the parameters of upper and lower bound random variable values which are defined for extrinsic and dependent level variable which exhibits the system goal seek behavior by resulting the exponential growth describes that the complexity index is mature in almost first to 2nd units of the time and there is no further increase with respect to the boundaries of the parameters as defined while the simulation completes its required runs. This case study is being designed for DFA analysis based assembly model of electric car battery to obtain the complexity indices of assembly. For comparative analysis, the new model is presented by transforming the existing linear model into a system dynamic model which has resulted the evolution of the trend and its extremities. Next, the model is further modified to study the impact of the manual and automatic feeding cost. It is found that with consideration of the human adaptability to change the learning curve is the core and part and parcel of the manual assembly process, the complexity increases as well as the time to assemble and hence the cost as well. Moreover, in this context a Case Study # 4.7, the

intrinsic random variables of annual cost fraction and cost per station with their random parameter boundary provides the dependent variable distribution to be a goal seek behavior which is having negative exponential growth; even when the Monte Carlo simulation completes its runs similar behavior pattern is observed in the level variable which exhibits the same behavior as the unit assembly cost for fixed automation variable apparently; seems reaching its saturation limit owing to the fact that the random variable upper and lower bound pre-defined limit within the system for intrinsic variable.

Furthermore, in the Case Study # 4.8 the intrinsic variables like assembly time per parts, number of parts per products and number of hours per shift produces the extrinsic variable of number of people distribution projects a goal seek behavior as the negative exponential growth is observed as the system evolution progresses with time. In this regard the level and extrinsic variable which is dependent on the intrinsic character of the annual labour cost variable, Intrinsic variable of annual production volume, intrinsic value of yield rate and number of people influencing the exogenous variable of the unit cost of the unit cost by manual assembly process. Here the distribution projects the goal seek behavior which is depicted in the Monte Carlo sensitivity run completes. However, the system evolution shows saturation of the projection owing to its upper and lower bound of random variable limit with negative exponential growth in the beginning of the unit of the time for both of the dependent level variables of the system. Furthermore, Case Study # 4.9 , in which the independent variables like assembled products fastenings, high level plant supplies, missing parts, low level ordinary plant supplies and storage of physical components are the variables which are independent and while physical component ramp up for ram-up is a dependent level variable. The Monte Carlo sensitivity runs exhibits a goal seek behavior pattern which is having negative exponential growth influencing the system. which is considerable owing to the random variables upper and lower bound limit as such that shows the fact that the saturation start quite early while evolution of unit of time is observed which is the indicator of the fact that the issues will be at the beginning as the ramp up operation seeks to proceed, and as there is no fluctuation in the extended final time horizon which means there is no further change in the system because of the intrinsic variables has low influence on the system behavior.

Lastly, In this case study 4.10 the intrinsic variable value of the independent variable such as equipment overhead ratio, equipment pay back, feeder cost, time spend in number of shifts and their respective dependent level variable value of total feed cost with max feed intrinsic variable value provides a goal seek behavior distribution projection with negative exponential growth in character. While similar behavior pattern is observed as the goal seek behavior is exhibited with the extrinsic level variable value of the dependent variable like the total cost of manually loaded Magazine. Whereas the independent variable intrinsic value in terms of capital investment and cost of Magazine along with the independent variable of rate of assembly workers, average cycle time and average manual assembly time per parts, in fact all the parts of the system together exhibits the same behavior pattern which is negative exponential growth progresses as the Monte Carlo simulation completes its run with in the random variable defined upper and lower bound limits of the system. However, total cost of assembly worker as the dependent level variable of the system exhibits quit opposite character where the distribution projection shows the goal seek behavior with positive exponential growth with declined character in its goal seek behavior as exhibit.

Finally, a novel suggestive comprehensive model is developed and analyzed with human behavior attributes. Some of these attributes were adopted from various core attributes of the Porter's theory of Motivation. While, some other important attributes such as nature vs. nurturing, genetic vs. learned IQ are also incorporated for consideration and analysis. This comprehensive model introduces and highlights all the major impacts of the motivation theory such as with given intrinsic and extrinsic rewards to the labor provides a complete understanding of the behavior pattern of the labour. As a result, it is found that the motivated workers have enhanced labor performance which can help in reducing the time period and cost of the ramp-up process. In this context, Case Study # 6.1 based on Motivation theory application has been carried out with indigenous novelty. The result of base run distribution has projected that when the rewards are reduced then the parameters intrinsic and extrinsic rewards with their core values the set distribution projections which enable us to understand that sharp decline of the goal seek behavior of positive exponential growth. As the satisfaction dependable level variables shows drops and so as

the personality traits just switching the rewards when distribution is projected over time. Next, the Monte Carlo sensitivity analysis enable us to understand the fact that the same if the reward is decreased from the 75% to 95% of the case approaching less than 50 units when reward is decreased, while in the case of higher rewards demonstrated behavior significantly higher for above 50 units when 75% to 95% shows the behavior pattern of random variables upper and lower bound limits of which is embedded in the system under study. The behavior of the system as exhibited found goal seek with negative exponential growth as the negative feedback loop seeks balance and stasis. However, the level variable of extrinsic value demonstrated the distribution projection behavior as a goal seek with positive exponential decay for the given random variable parameters upper and lower bound as defined in the system. It has been observed that with higher amount of reward attracts more for the change but that change brings the higher level of satisfaction, and the curve fitting seems mature and saturated. Like sponge cannot take more water. Now if the reward is gradually increased with passage of time, will increase with the same ratio, because of reason a person cannot be motivated all the time as excitement may be increased with the passage of time gradually and it is better than reaching at ascertain saturation. For instant for bigger incentive with expectation of employ behavior change will make them saturated quickly. While on the other hand with normal work load a significantly balanced small portion of reward will continuously improve the behavior, nobody can work twice equal proportion learning with the amount of time that will become saturated. New knowledge should be a small portion of the normal work load to keep a person motivated. Otherwise saturation will occur instead of generalizing incentives there should be group wise change in the process of learning, if one is achieved then next phase of learning to be brought obviously this within the context of the ramp up where sociotechnical aspect of motivation and satisfaction are highly desirable. Therefore, it is concluded that sociotechnical elements especially the labor learning and motivation factors are not only significant for timely development of continuous and dynamic fast ramp up processes but also have non-linear complexity indices owing to the design and manufacturing process complexity. Also, it is suggested that the product and processes involved in the ramp up envisages greater care right from the beginning and goes hands and gloves with R&D to develop solutions to the complexity indices of the

non-linear sociotechnical elements of the system considering hard and soft enablers in focus. The final conclusion is that the evolution of complexity of system of systems (SOS) transforms into a large scale sociotechnical system when it comes to fast manufacturing ramp-up phase which proves our hypothesis and thesis statement.

Finally, this research recommends the following for the future challenges which are needed to be explored as such:

- 1) Human behaviour model which generally referred to as the factor five model if integrated by using system dynamic for labour behaviour modeling in order to study individual behavior in long time projection which can depict the personality type in to a dynamic perspective and hence this can be a vital contribution asset for the management to understand the man machine and work task relation in a new way.
- 2) Future work can be extended to the other associated facts of the sociotechnical system with particular influence of design, manufacturing and system level. No doubt the designer can be biased and so as the technical personnel that is why the human resources has to keep the performance level and its ranking for everyone impartially which is obviously very tricky scenario to cope with.
- 3) Absenteeism is a challenge and an important issue to be incorporated along with the study by implementing factor-5 personality pillars of traits modeling especially for public organizations.
- 4) Finally, a complete system of systems (SOS) based study involving single product needed to be performed which not only involve socitiotechnical element of assembly and disassembly levels by applying DFA and DFM principles and their respective complexity indices projections as well as also include the aggregate planning and lot sizing capacity and supply chain in bound and out bound routing quality and learning issues with market dynamics will be an added asset for quick understanding the behaviours for maintaining a competitive edge through multi faceted and multi focus analysis by using system dynamics.

REFERENCES

- Ali-Qureshi, Z. (2011), " System of Systems Based Complexity analysis for New Product Design", Proceedings of ASME's International Design Engineering & Technical Conference, (IDET- 2011), Washington D.C., USA.
- Arafa A. (2011), Dynamic Analysis for Enterprise Strategic Flexibility using System Engineering Methodology, Ph.D Thesis University of Windsor.
- Almgren, H.(2000), "Pilot Production and Manufacturing Start-Up: the case of Volvo S80" International Journal of Production Research: 38 (17), 4577-4588.
- Almgren,H. (1999) "Start-up of advanced manufacturing systems – a case study", Integrated Manufacturing Systems, Vol. 10 Iss: 3, pp.126 - 136
- Baloff, (1970). Startup management, Engineering Management, IEEE Transactions on (Volume:EM-17 , Issue: 4)
- Bayus, B. L. (1997), Speed-to-Market and New Product Performance Trade-offs. Journal of Product Innovation Management, 14: 485–497. doi: 10.1111/1540-5885.1460485
- Bart H. (2004), The Lean Design Solution, Publisher: Institute for Lean Design (November 20, 2004)
- Ball, P D., Roberts, S., Natalicchio, A. and Scorzafave, C. (2011), Modelling production ramp-up of engineering products, Proceedings of the Institution of Mechanical Engineers, Part B: Journal of Engineering Manufacture, June 2011, vol. 225, no. 6, pp. 959-971
- Baltagi, Y. ; Rosi, D.L.; Tancorre, V.; Garagnon, C.; Faehn, E.; Barone, M.; Appello, D.; Suzor, C. (2011), Embedded memory fail analysis for production yield enhancement. 22nd Annual IEEE/SEMI Advanced Semiconductor Manufacturing Conference (ASMC 2011), 16-18 May 2011, Saratoga Springs, NY, USA; Electron Devices Soc.; Publisher: IEEE, Piscataway, NJ, US.
- Baard, P. P.; Deci, L.E. and Ryan U.M.R (2004), Intrinsic Need Satisfaction: A Motivational Basis of Performance and Well-Being in Two Work Settings, Journal of Applied Social Psychology, 2004,34, 10, pp. 2045-2068. Copyright 0 2004 by V. H. Winston 8, Son, Inc. All rights reserved.
- Boothroyd G. (2005), Assembly Automation and Product Design Second Edition, Published by CRC- Taylor and Francis Group.
- Campbell, M., (2010), The product complexity and test - How product complexity impacts test industry,15th IEEE European Test Symposium (ETS 2010), 15th IEEE European Test Symposium (ETS 2010), Piscataway, NJ, USA.
- Ceglarek, D. and Junshi, J.(1995), Dimensional Variation Reduction for Auto body Assembly, Manufacturing Review, Vol.8, No.2 .1995.

Closs, D. J. Nyaga, G.N., Voss, M. D. (2010), The differential impact of product complexity, inventory level, and configuration capacity on unit and order fill rate performance, *Journal of Operations Management*, v 28, n 1, p 47-57, January 2010.

Cohen, M.A., Huchzermeier, A. (1999), Global Supply Chain Management: A Survey of Research and Applications" in Tayur, S., Magazine, M., Ganesh, R. (Eds.), *Quantitative Models for Supply Chain Management*, Boston: Kluwer Academic Press, pp.669-702.

Dangayach, G. and Deshmukh, S., (2001), Manufacturing strategy: literature review and some issues. *International Journal of Operations & Production Management*, 21 (7), 884-932.

Dashchenko A.I. (Ed.) (2006) *Reconfigurable Manufacturing Systems and Transformable Factories*, Springer-Verlag Berlin Heidelberg (2006), Printed in The Netherlands.

De Weck O.L., Daniel Roos, Christopher L. Magee, Charles M. (FRW) Vest (2011), *Engineering Systems: Meeting Human Needs in a Complex Technological World* by Publisher: The MIT Press (2011).USA.

Dornfeld, D. A. (Ed.) (2012), *Green Manufacturing, Fundamentals and Applications*, Published by Springer New York Heidelberg Dordrecht London.

<http://www.springer.com/978-1-4419-6015-3>.

Dombrowski, U.; Hanke, T. , (2011) Lean ramp-up Fields of Action and Design: Doing the right things right from the beginning (2011), Source: *ZWF Zeitschrift für Wirtschaftlichen Fabrikbetrieb*, v 106, n 5, 332-6, May 2011; Language: German; ISSN: 0932-0482; Publisher: Carl Hanser Verlag GmbH, Germany Inspec database.

Dombrowski, U, Hanke, T.(2009), Lean ramp-up - an organization model for efficient series ramp-ups in SME Source: *ZWF Zeitschrift für Wirtschaftlichen Fabrikbetrieb*, v 104, n 10, p 877-83, Oct. 2009 Language: German, Database: Inspec.

Doltsinis, S. C., Ratchev, S., Lohse, N., (2013), A framework for performance measurement during production ramp-up of assembly stations, *European Journal of Operational Research*, v 229, n 1, p 85-94, August 16, 2013.

Duncan, J. (2010), *Applied Mechanics for Engineers*, re-published by Nabu press. Old edition available online www.archive.org/details/appliedmechanics00duncrich

Deif, A.M. and ElMaraghy W.H., A control approach to explore the dynamics of capacity scalability in reconfigurable manufacturing systems, *Journal of Manufacturing Systems - J Manuf Syst* 01/2006; 25(1):12-24.

ElMaraghy W.H.(2013) Key note address in Cairo, Egypt, E-mail reference personal correspondence.

ElMaraghy W.H., ElMaraghy H.A, Tomiyama, T., Monostori, L. (2012), Complexity in engineering design and manufacturing, *CIRP Annals– Manufacturing Technology* 61 (2012) 793–814.

ElMaraghy W.H. and R. J. Urbanic (2003), Assessment of Manufacturing Operational Complexity, *CIRP Annals* (2003).

ElMaraghy, H.A. (Edition) (2009) *Changeable and Reconfigurable manufacturing Systems*, © Springer 2009

Felipe J., Kumar, U., Abdon, A., Bacate M. (2012), Product complexity and economic development, *Structural Change and Economic Dynamics*, v 23, n 1, p 36-68, March 2012.

Forsberg K. , Mooz H. (1991), The Relationship of System Engineering to the Project Cycle, Joint conference of National Council On Systems Engineering (NCOSE) and American Society for Engineering Management (ASEM) , Chattanooga, TN.

Forester, J. (1961)*Industrial Dynamics*. Pegasus Communications.

Gausemeier, J, Schäfer W, Eckes R, Wagner R. (2005), Ramp-Up and Maintenance with Augmented Reality in Development of Flexible Production Control Systems, CARV 05, International Conference on Changeable, Agile, Reconfigurable and Virtual Production.

Groover, M.P.(2007), *Automation, Production Systems, and Computer-integrated Manufacturing* , Publisher : Prentice Hall; 3 edition (24 July 2007)

Geels, F.W. (2004) ,From sectoral systems of innovation to socio-technical systems Insights about dynamics and change from sociology and institutional theory. *Research Policy* 33,(2004) 897–920.

Glock, C. H., Jaber M.Y., Zolfaghari, S. (2012), Production planning for a ramp-up process with learning in production and growth in demand, *International Journal of Production Research*, v 50, n 20, p 5707-5718, October 15, 2012.

Gunther Schuh (2005), Jens-Christian Desoi and Gregor Tucks, *Holistic Approach For Production Ramp-Up In Automotive Industry*, *Advances in Integrated Design and Manufacturing in Mechanical , Engineering*, 2005. Pp 255-268.

Hackman , J.R. and Oldham, R.G.(1976), Motivation through the design of work: test of a theory , *Organizational Behavior and Human Performance*, Volume 16, Issue 2, August 1976, Pages 250–279. [http://dx.doi.org/10.1016/0030-5073\(76\)90016-7](http://dx.doi.org/10.1016/0030-5073(76)90016-7).

Hyman, B. (1998), *Fundamentals of Engineering Design*, Published by Prentice-Hall, Inc. New Jersey, USA.pp-374.

Harrington, J. Jr. (1984) *Understanding Manufacturing Process, key to successful Cad/Cam Implementation*, by Marcel Dekker, inc.USA

Kampker A., Burggraf Peter., Carsten, N., (2012) Costs, quality and scalability Impact on the value chain of electric engine production Source:; Conference: 2012 2nd International drives production Conference, EDPC 2012, October 15, 2012 - October 18, 2012; Publisher: IEEE Computer Society.

- Kossiakoff, A. and Sweet W.N. (2003), *Systems Engineering Principles and Practice*, John Willey And Sons .
- Koren Y. (2010), *The Global Manufacturing Revolution: Product-Process-Business Integration and Reconfigurable Systems*, Published by John Wiley & Sons. New Jersey, USA.
- Laurène S., (2010), *Problem And Interface Characterization During Ramp-up In The Low Volume Industry* , Ph.D Thesis, Prepared at the Laboratoire G-SCOP, Laboratoire des Sciences pour la Conception, l'Optimisation et la Production de Grenoble (UMR5272), Equipes Conception Collaborative et Gestion et Conduite des Systèmes de Production, 46 avenue Félix Viallet, 38031 Grenoble Cedex 1, France.
- Lanza Gisela. and Sauer, A. (2012), *Simulation of personnel requirements during production ramp-up*, *Production Engineering*, v 6, n 4-5, p 395-402, September.(2012)
- Lee, J.; Chiao-Lin Deng ; Chia-Hsi Tsan; AbuAli, M., *Product life cycle knowledge management using embedded Infotronics: methodology, tools and case studies*, *International Journal of Knowledge Engineering and Data Mining*, v 1, n 1, 20-36, 2010; Publisher: Inderscience .
- Lenfle Sylvain and Midler Christophe (2009): *The launch of innovative services : lessons from automotive telematics*, *Research Policy*, Volume 38, Issue 1, February 2009, Pages 156–169
- Liu, Z., Wong Y.S., Lee K.S. (2010), *Modularity analysis and commonality design: A framework for the top-down platform and product family design*, *Source International Journal of Production Research*, v 48, n 12, p 3657-3680, January 2010.
- Liu Z., Wong Y.S., Lee K.S. (2011), *A manufacturing-oriented approach for multi-platform forming product family design with modified genetic algorithm*, *Journal of Intelligent Manufacturing*, v 22, n 6, p 891-907, Dec. 2011.
- Luh, Ding-Bang, Ko, Yao-Tsung, Ma, Chia-Hsiang (2011), *A structural matrix-based modelling for designing product variety*, *Journal of Engineering Design*, v 22, n 1, p 1-29, January 2011; ISSN: 09544828, E-ISSN: 14661837; Publisher: Taylor and Francis Ltd.
- Matta, A. , Tomasella, M., Valente, A. (2007), *Impact of ramp-up on the optimal capacity related reconfiguration policy*. *Int J Flex Manuf Syst* (2007) 19:173–194, Springer Science+ Business Media, LLC 2007.
- Maier M.(1998) Maier M.W., *Architecting Principles for System-of-Systems CH1-460*, The Aerospace Corporation, Chantilly, VA 20151
- Musch, T. and Schiek, B. (2000), *Measuring the ramp linearity of extremely linear frequency ramps using a fractional dual loop structure*, Source: *CPEM Digest (Conference on Precision Electromagnetic Measurements)*, p 577-578, 2000.
- Muller G. (2011), *Systems Architecting: A Business Perspective*, CRC press.

- Nau, B., Roderburg, A., Klocke F. (2011), Ramp-up of hybrid manufacturing technologies, *CIRP Journal of Manufacturing Science and Technology*, v 4, n 3, p 313-316, (2011).
- Nof Shimon Y. (1999), *Handbook of Industrial Robotics*, second edition, John Wiley & Sons, Inc. , New York, Singapore, Toronto.
- Nof, Shimon Y. Wilbert E. Wilhelm, and Ilans-Jiirgen Warnecke (1997), *Industrial Assembly*, Published by Chapman & Hall, 2-6 Boundary Row, London SE1 8HN, UK
- Nugroho, Y.K. (2011), Production ramp up in built-to-order supply chains, *Journal of Modeling in Management*, v 6, n 2, p 143-63, (2011).
- Orfi, N. , Terpenney, J., Sahin-Sariisik, A. (2011) , Harnessing product complexity: Step-1establishing product complexity dimensions and indicators, *Engineering Economist*, v 56, n 1, p 59-79, January 2011.
- Owen A. E. (Tony) (1984), *Flexible Assembly Systems Assembly by Robots and Computerized Integrated Systems* Bicichley, United Kingdom, Plenum Press, London.
- Pearn, W.L., Hung, Hui Nien, Cheng, Ya Ching, Lin, Gu Hong (2010), Procedure of the convolution method for estimating production yield with sample size information, Source: *International Journal of Production Research*, v 48, n 5, p 1245-1265, January 2010; ISSN: 00207543, Publisher: Taylor and Francis Ltd.
- Prenting, T. O. (1974), *Humanism and technology in assembly line systems*, published by Spartan Books; Hayden Book Co., Rochelle Park, N.J.
- Pang. N. T. (2004), *Essentials of Manufacturing Engineering Management*, First Edition, Universe, Inc.2021 Pine Lake Road. Suite 1, Lincoln. NE 68512, USA. www.iuniverse.com
- Porter, W.L and Lawler E.E. (1968), *Managerial Attitudes and Performance*, p.17. Home wood Illonoi, Irwon Dorci Press, USA.
- Reinhart, G., Wu"nsch, G. (2007), Economic application of virtual commissioning to mechatronic, production systems, *Prod. Eng. Res. Devel.* (2007) 1:371–379.
- Roy R., R Evans, M J Low, and D K Williams D.K. (2011), Addressing the Impact of High Levels of Product Variety on Complexity in Design and Manufacture, *Proceedings of the Institution of Mechanical Engineers, Part B: Journal of Engineering Manufacture*, v 225, n 10, p 1939-1950, October 2011.
- Samin Shokri (2008), *Modeling of Assembly System Complexity in Manufacturing* MA.Sc. thesis, Department of Industrial and Manufacturing Systems Engineering, University of Windsor (Canada), 2008.
- Sule D.R. (2008), *Production planning and industrial scheduling, Examples, Case Studies and Applications* Second Edition, CRC-Press Taylor and Frances Group.
- Suh, N.P., (2005), *Complexity Theory and Applications*. Publisher, Oxford University Press, USA.

Sanayei, A., Monplaisir, L.F. (2012), Integrating product life cycle issues in technology selection, Portland International Conference on Management of Engineering & Technology (PICMET), p 1401-7, 2012.

Schuh G., Lenders, M., Nussbaum C. and Kupke1, D., (2009), Design for Changeability ElMaraghy H.A. (ed.) (2009): Changeable and Reconfigurable Manufacturing Systems. Publisher Springer Verlag.

Schwab. P.D. and Cummings. L.L, (1970), Theories of Performance and Satisfaction: A Review, Industrial Relations: A Journal of Economy and Society Volume 9, Issue 4, pages 408–430, October 1970. Re published.

Sidhartha R (2010), Standardization of product development process in multi project organizations doctoral dissertation, MIT system engineering division.

Shamsuzzoha, A.H.M., Helo, P.T. (2009), Managing product variety through component commonality: concept and application Source: International journal Management and Enterprise Development, v 7, n 2, 183-99, 2009; ISSN: 1468-4330; DOI: 10.1504/IJMED.2009.025949; Publisher: Inderscience Enterprises Ltd., Switzerland.

Stablein, T., Holweg, M., Miemczyk, J. (2011) ,Theoretical versus product variety: how much customisation do customers really demand, International Journal of Operations & Production Management, v 31, n 3, 350-70, 2011; Publisher: Emerald, UK.

Schuh, G., Desoi JC and Tücks G. (2005), Holistic Approach For Production Ramp-Up In Automotive Industry, Bramley A., Brissaud, D., Coutellier , D and McMahan, C. (eds.), Advances in Integrated Design and Manufacturing in Mechanical Engineering, 255-268. © 2005 Springer. Printed in the Netherlands.

Sterman, J.D.(2000), Business Dynamics, System Thinking and Modeling for Complex World Publisher: McGraw-Hill Higher Education (2000)

Swanekamp, R., (1995) Ramp Up Operating Flexibility with Variable Frequency Drives, Source: Power, v 139, n 9, 66, 68, 70, Sept. 1995; ISSN: 0032-5929; publication: USA, inspec.

Thomas, L.C.; Possani, E.; Archibald, T.W. (2003), How useful is commonality? Inventory and production decisions to maximize survival probability in start-ups, Source: IMA Journal of Management Mathematics, v 14, n 4, 305-20, Oct. 2003; Publisher: Oxford University Press for Inst. Math. Appl, UK.

Tkachenko, N., Fedorchuk, E. (2010), Optimization model to research assess the impact of quality and cost indicators of product life cycle, VI-th International Conference on Perspective Technologies and Methods in MEMS Design (MEMSTECH), p 85-6, 2010.

Tsubone, H., Matsuura, H., Satoh, S. (1994), Component part commonality and process flexibility effects on manufacturing performance Source: International Journal of Production Research, v 32, n 10, 2479-93, Oct. 1994; ISSN: 0020-7543;Published in UK

Van Iwaarden, J., van der W. T. (2012), effects of increasing Product Variety and shortening product life cycles on the use of Quality Management Systems, *International Journal of Quality and Reliability Management*, vol. 29, no. 5, page 470-500, 2012;

Vroom, V. H. (1964). *Work and motivation*. Publisher: Jossey-Bass; 1 edition (November 10, 1994), San Francisco, CA, USA.

Von Gleich C.F., Schutt, A., Isenberg, R. (2012), SMART ramp-up: methods to secure production ramp-up in the aircraft industry. Read at the German Aerospace Congress, September 27–29, 2011, Bremen, Germany.

Wazed, M.A., Ahmed, S., and Bin Nukman, Y. (2011), Mathematical models for process commonality under quality and resources breakdown in multistage production, Source: *Journal of Zhejiang University Science A*, v 12, n 11, p 837-48, Nov. 2011.

Wazed, M.A. Ahmed, S.; Nukman, Y. (2010), Commonality in manufacturing resources planning issues and models: a review, Source: *European Journal of Industrial Engineering*, vol 4, no. 2, 2010.

Xiao-pu Jiang; Chang-jiang Ma, (2011) "Concerning the important position of product modeling design in the product life cycle strategy," *Industrial Engineering and Engineering Management (IE&EM)*, 2011 IEEE 18Th International Conference on , vol.Part 1, no., pp.540,542, 3-5 Sept. 2011

APPENDICES

Appendix A Glossary of useful Important Terms

System

A system "an integrated set of elements that accomplishes a defined objective purposes. Next, these elements include products like wise (hardware, software, firmware), processes (policies, laws, procedures), people (managers, analysts, skilled workers), information (data, reports, media), techniques (algorithms, inspections, maintenance), facilities (hospitals, manufacturing plants, mail distribution centers), services (evacuation, telecommunications, quality assurance), and other support elements".

System Thinking

System thinking is a kind of holistic philosophical capability of uncovering critical System Structure such as boundaries, inputs, output, Spatial Orientation process structure and complex interaction of system with their Environment.

System Functionality

Systems have interconnected and interacting elements that perform systems functions to meet the needs of consumers for products and services. Systems have objectives that are achieved by system functions. Systems interact with their environment thereby creating effects on stakeholders.

System Engineering

Systems require systems thinking that uses a systems engineering thought process. Systems use technology that is developed by engineers from all engineering disciplines. It is a holistic, logically structured sequence of cognitive activities that support system design, system analysis, and system decision making to maximize the value delivered by a system to its stake holder for resources.

System Life Cycle

Systems have a system life cycle containing elements of risk that are managed throughout this life cycle by engineering managers. Systems require systems decisions, analysis by systems engineers, and decisions made by engineering managers.

System Dynamics

System dynamics is a tool to help address complex issues involving delays, feedback, and nonlinearities, system dynamics is a methodology for studying and managing complex feedback systems, such as one finds in business and other social systems.

System Complexity

The science of complexity has many origins in many disciplines. Complex Systems are composed of a certain amount of entities which interacting together. A system behavior is said to be complex if the system is difficult to analyze predict or manage. On the other hand system is said to be complex structurally when the number of parts are large and

their relative inter connection is intricate and hard to describe. System that are composed of the complex structure usually behave complex as well.

Time Independent Real Complexity

Real complexity and imaginary complexity—are defined to deal with real uncertainty and imaginary uncertainty, respectively. In the time-independent situation, there are two kinds of complexity, real complexity and imaginary complexity, which are orthogonal to each other. Total complexity defined to be the vector sum of the real and the imaginary complexities.

Time Dependent Imaginary complexity

Imaginary complexity is defined as uncertainty that is not real uncertainty, but arises because of the designer's lack of knowledge and understanding of a specific design itself. For example, a combination lock is easy to open once we know the sequence of numbers we have to activate, but in the absence of the information on the combination, it would appear to be complex. This uncertainty, which is not real but associated with the lack of knowledge, is defined as the imaginary complexity.

Time Dependent Periodic complexity

In the time-dependent complexity arena, there are two kinds of complexity, combinatorial complexity and periodic complexity. In a system that is subject to combinatorial complexity, the uncertainty of the future outcome continues to grow over time, and as a result, the system cannot have long-term stability and reliability. In the case of systems with periodic complexity, the system is deterministic and can renew itself over each period. Therefore, a stable and reliable system must be periodic. A system with time-dependent combinatorial complexity can be changed to a system with time-dependent periodic complexity. The time-dependent periodic complexity requires that a set of functions repeat periodically. At the beginning of each period, the initial state of the system (i.e., the FRs) must be determined to reinitialize the system. The functional periodicity can be obtained by many different means: temporally, geometrically, biologically, chemically, thermally, and electrically. Also they can be controlled by manufacturing processes, information processes, and circadian cycles.

Complicated Systems

It is referred as many elements and many inter-dependencies; the most important of all the system behavior is deterministic. The is said to be complicated when large number of parts and variety of system elements involved. But in this case the system variety and their interdependent parts can be ascertained at minimum level which is thus not complex. It is pertinent to note the fact solving complicated tasks can be achieved through an descriptive approach using models, methods, planning and simulation.

Simple Systems

It is describe as the system which is composed of the few elements, which holds the interdependences, and have behavior possibilities.³ A simple is the one which is easily knowable.

Complex Systems

It is the system which holds few elements and inter-dependencies; but it entails the high number of behavior possibilities and hence the entire controllability of the system is not possible. But in a system where as the complicated part is characterized by prediction the complex part of the production system is then hence categories due to its characteristics by its unpredictable behavior and owing to its undeterminable nature. In short, complexity exists when emergence comes in to action.

Complex and Complicated Systems

This is the one which is composed of the elements and does have interdependence ; but high changeability of system elements over time. A car is complex and complicated product system like wise airplanes and commuter trains etc

Linear Growth of System

It is the system which follow a straight line plot while the slop goes either up or down. But if the system exhibits the growth or decay then sum of all in flow in the stock of system minus all out flow of the system must be constant. It is the system in which the stock of the system which is constant changes over time. If the system constant value is +ve then the growth is linear and if the constant value is -ve then decay is linear. If the constant suppose is zero then the stock of the system will remain constant throughout the time.

Exponential Growth or Decay

If the stock of the system increases then the growth is exponential while the stock of the system decreases then the decay is exponential. The bucket example where water volume with time decreases and represents the example of the exponential decay. Similarly the GDP growth can represent exponentially the growth of commodities market to grow exponentially as higher ends of wealth bring new consumptions of the market products which grows exponentially as the middle class become stronger in the society. this is similar to the mating period where the growth of the mice is double exponentially as long as they survive.

Logistic Growth

It occurs when the system exhibits the exponential growth behavior in such a way that the given constraint facilitates the growth patterns and then max. level is achieved while the system reaches a sustaining state here the further growth is halt and system maintains a steady state growth and do maintains that sustainably for a longer period of time.

Appendix -B Basic IDEFo concept based analogy model for Ramp-up

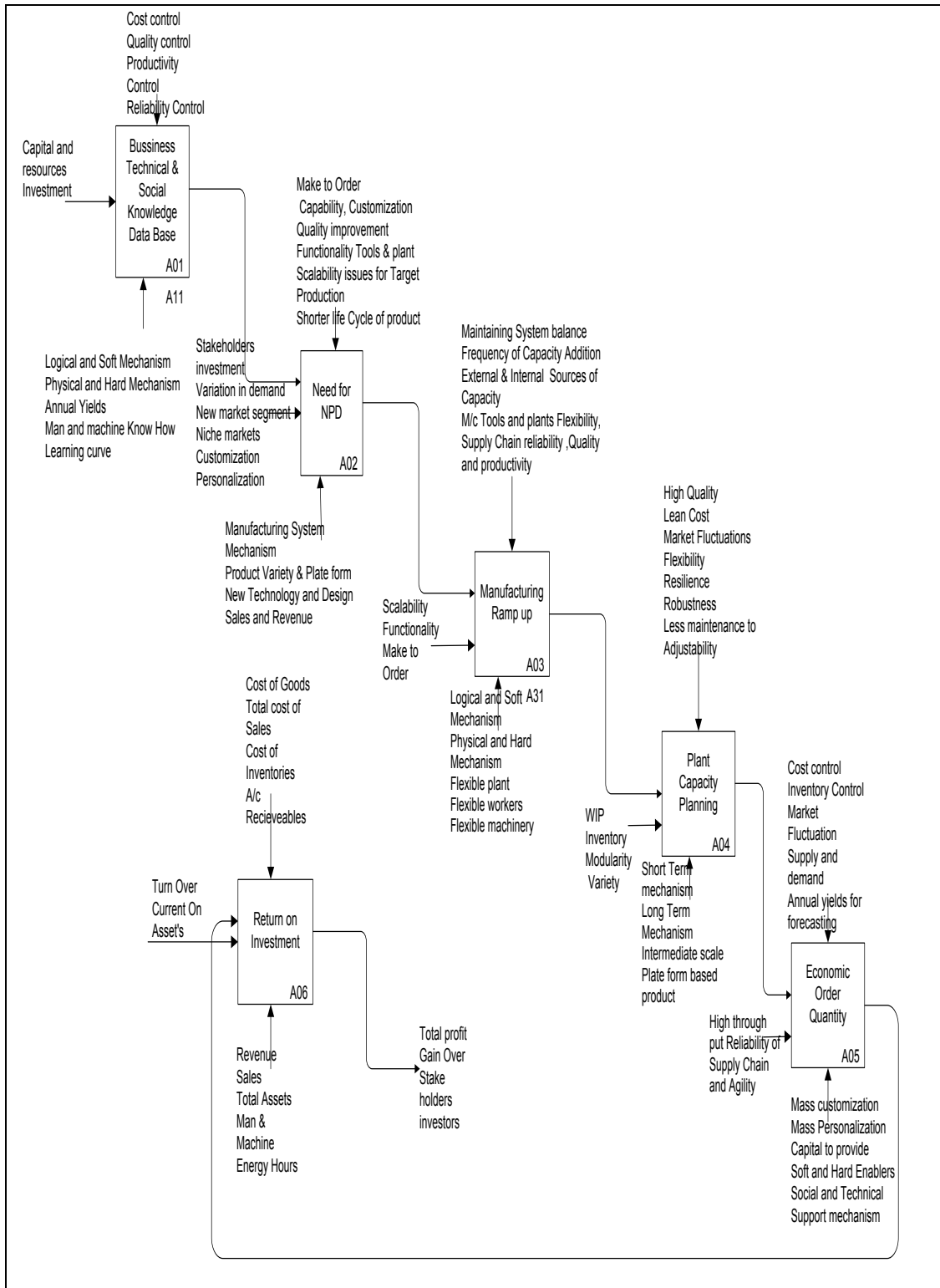

Basic IDEFo concept based analogy model for Ramp-up

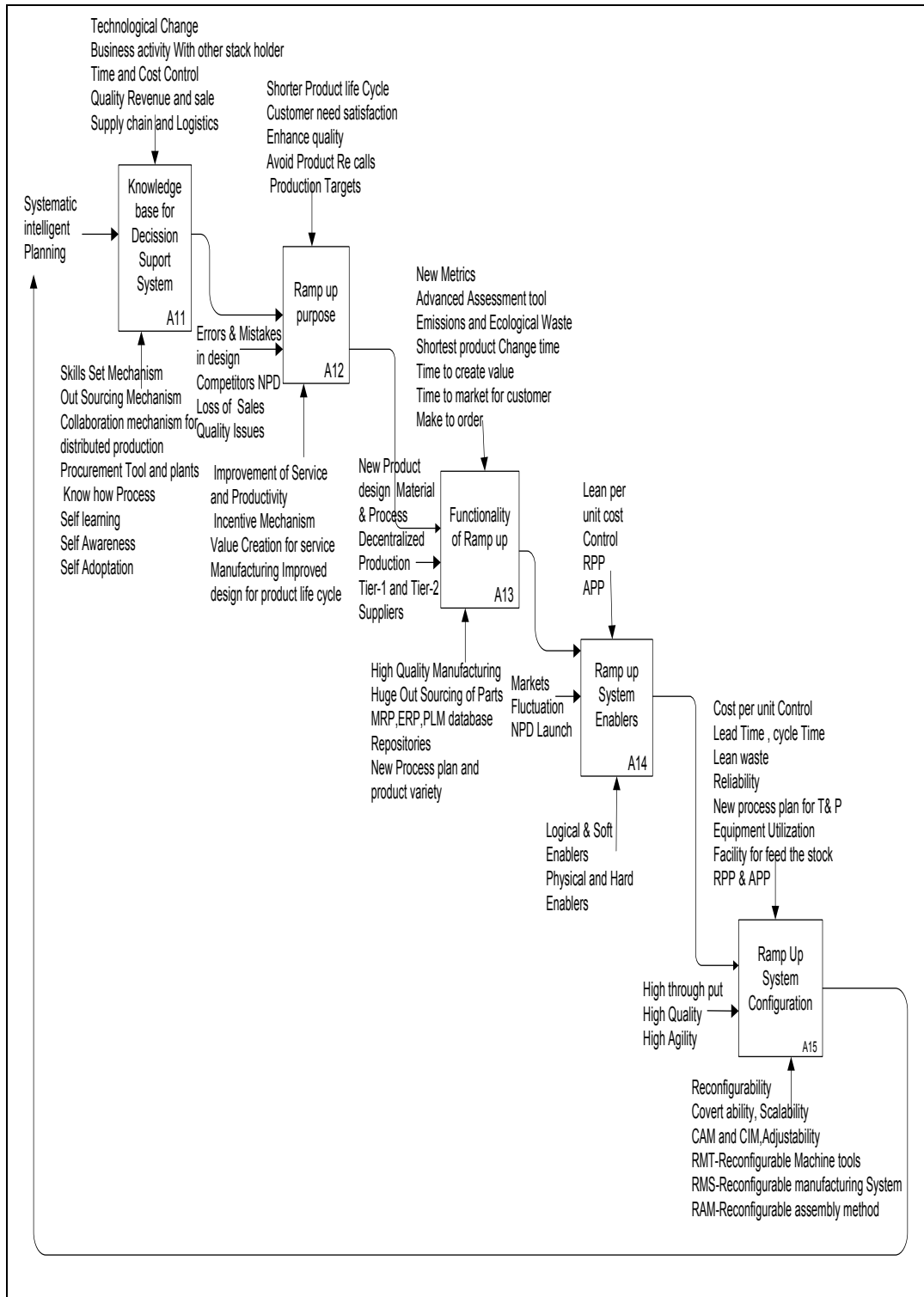

Appendix C Modern Modeling Tools for Systems Dynamics

Modeling Tools

System dynamics was developed in 1950 by Jay W. Forrester in Massachusetts Institute of Technology (MIT). System dynamics simulation is performed to learn about the dynamics of the system behavior. Using system dynamics helps in understanding the behavior and evolution of complex systems over time where the state of the system is the function at the current time, while the state of the system at the previous time instance, and time which changes between the two. Following are the major tools which are used in Industry and academia. most famous are as such, Analytica, Any logic, VisSim, Vensim, i- think, Power Sim, etc.

Analytica

Analytica's influence diagrams make models easier to create, communicate, and maintain. It's easy to develop a graphical user interface that permits clients to do scenario analysis with little effort. Analytica offers an efficient and effective framework, which stems from its intelligent array algorithm. It offers users the flexibility to start simple, and extend to multi-dimensional models. It also allows for greater responsiveness to stakeholder's requests for new scenarios or technologies with minimal effort. Analytica has been used for policy Analysis, business modeling and risk analysis, areas in which it is being used includes the health energy pharmaceuticals, environmental risk, emission policy analysis wild life planning, R & D planning and portfolio management, financial services, aerospace, manufacturing and environmental health impact assessment. It also support the system dynamic, MonteCarlo Simulation, array abstraction, Linear and Non linear optimization. It uses the influence diagrams to define, navigate and document models.[1]

Anylogic

Any Logic is a simulation tool that supports most of the common simulation methodologies in place today: System Dynamics, Process-centric Discrete Event, and Agent Based modeling. The unique flexibility of the modeling language enables the user to capture the complexity and heterogeneity of business, economic and social systems to any desired level of detail. Any Logic's graphical interface, tools, and library objects allow you to quickly model diverse areas such as manufacturing and logistics, business processes, human resources, consumer and patient behavior. Any Logic's visual development environment significantly speeds up the development process. The included object libraries provide the ability to quickly incorporate pre-built simulation elements. Reusability through fully object oriented structure. A visual integrated development environment makes it easy to convert from other widely used IDEs to Any Logic. Pre-built object libraries show how the experts did. Those objects can be easily reused. The native Java environment provides multi-platform support. Both the Any Logic IDE and models work on Windows, Mac and Linux. You don't need a runtime license — with one click you can generate a Java applet that allows users to run a model anywhere. An Any Logic model is completely separable from the development environment and can be exported as a standalone Java application. Develop agent-based, system dynamics, discrete-event, continuous and dynamic system models, in any combination, with one tool. Any Logic supports the seamless integration of discrete and continuous simulations.

application areas include the Supply Chains, Logistics, Healthcare and pharmacy, marketing and competition, manufacturing and production, pedestrian flows airports, stations, malls transportation and warehousing project, asset management business processes and service systems railroads, military and defense, IT and telecom strategic Planning and Management , Social , Processes. The native Java environment supports limitless extensibility including custom Java code, external libraries, and external data sources. An extensive statistical distribution function set provides an excellent platform for simulating the uncertainty inherent in all systems. A powerful experimental framework, built-in support for Monte Carlo simulations and advanced forms of optimization support a wide variety of simulation approaches.[2]

Vis Sim

VisSim™ is a block diagram language for creating complex nonlinear dynamic systems. To create a model, simply drag blocks in the workspace and connect them with wires. Then click the Go button to initiate your simulation. The response is instantaneous. You can choose to display your response in 2D or 3D plots, gauges, bar charts, meters, digital readouts, and even 3D animated scenes. All are driven in real time using the VisSim engine. VisSim's highly tuned math engine executes your diagram directly with no compilation delay. By combining the simplicity and clarity of a block diagram interface with a high-performance mathematical engine, VisSim provides fast and accurate solutions for linear, nonlinear, continuous time, discrete time, SISO, MIMO, multi-rate, and hybrid systems. With VisSim's wide selection of block operations and expression handling, complex systems can be quickly entered into VisSim. VisSim's tightly integrated development platform makes it easy to pass freely among the stages of model construction, simulation, optimization, and validation. This means you can create virtual prototypes on your desktop and make sure they're working properly before committing to the design. And because *VisSim* eliminates traditional programming, your learning time is minimal.[3]

Vensim

It is the best system dynamic tool which is used for the business dynamics and its behavior studies. Forester (2000) and Arafa (2011) used this tool in their work for modeling. The best aspect of modeling the discrete variable and continuous variable can be made simply by defining the random variable. However, more complex problems require the professional level programming and practice to reach a level of perfection. It has built in full modeling language controls and its DSS version comes with full functionality while for student a free version is also available with limited functionality level to make one go. Other software tool like i-think and power-sim can be used for the same purpose but has some differences of control and codal procedure and built in libraries are different icons are different and off course the assembly language and their respective algorithm are different with which they take the user input in their interface.

References:

[1] <http://www.lumina.com/>

[2] <http://www.anylogic.com/overview>.

[3] <http://www.vissim.com/products/vissim.html>

[4] <http://vensim.com/>

Appendix D Simulation Control Parameters of Selected Ram-up Model Problems

This appendix presents the model sketch back end programming controls and parameters. This is the language code which can also be changed and command and functions can be define in the run time environment. This provides flexibility and more user friendly approach to the molder who can make changes not from just drop down menus only but at the professional programming level new algorithms can also be created when programmer writes his own programming code. The programming controls are integrated with the C language which makes this application software to communicate with the operating system software commands outside the domain of the programming which makes the arithmetic logical unit to understand the input and proceed for the output as desired by the modeler. Here, assembly language of the programme is very cool as it is not as complex as the java virtual engines which facilitates the entire process irrespective of the plate form of operating system. Only, important thing, this user friendly environment is comes with Vensim DSS version only. Off course, it is not like Linux Red-Hat operating system which keeps improving throughout the globe being having an open source code. However, initial learning version offered by Vensim PLE is free for educational purpose only, but PLE+ with multivariate simulation feature is not free. But both version does not support this facility to manipulate the programs in run time environment by just saving changes while keep developing.

Model-1

2.5

~ Million Products/Year
~ |

Economic order Quantity= INTEG (
 (Procurement Cost of RAS*Annual usage Target/Rate of Carrying
 Cost*Price of Each Product\
)^1/2,
 Present capacity)
~ Products/Year
~ |

Present capacity=
8.75*10^3
~ Products/Year
~ |

Price of Each Product=
15.5*10^3
~ Dollars/Product
~ |

Procurement Cost of RAS=
34.8
~ Million Dollars
~ |

Rate of Carrying Cost=
0.0036*1/100*Economic order Quantity
~ Dollars/Product
~ |

.Control
*****~

Simulation Control Parameters

|
FINAL TIME = 10
~ Year
~ The final time for the simulation.
|

INITIAL TIME = 0
~ Year
~ The initial time for the simulation.
|

SAVEPER =
TIME STEP
~ Year [0,?]
~ The frequency with which output is stored.
|

TIME STEP = 1
~ Year [0,?]
~ The time step for the simulation.
|

\\--// Sketch information - do not modify anything except names
V300 Do not put anything below this section - it will be ignored
*View 1

\$192-192-192,0,Times New Roman|12||0-0-0|0-0-0|0-0-255|-1--1--1|-1--1--
1|96,96,100,0
10,1,Economic order Quantity,488,534,51,34,3,131,0,0,0,0,0,0
10,2,Procurement Cost of RAS,428,387,58,19,8,3,0,0,0,0,0,0
10,3,Annual usage Target,636,396,43,19,8,3,0,0,0,0,0,0
12,4,48,233,531,10,8,0,3,0,0,-1,0,0,0
1,5,7,1,4,0,0,22,0,0,0,-1--1--1,,1|(391,531)|
1,6,7,4,100,0,0,22,0,0,0,-1--1--1,,1|(288,531)|
11,7,48,340,531,6,8,34,3,0,0,1,0,0,0
10,8,Rate of Carrying Cost,340,558,53,19,40,3,0,0,-1,0,0,0
12,9,48,825,539,10,8,0,3,0,0,-1,0,0,0
1,10,12,9,4,0,0,22,0,0,0,-1--1--1,,1|(749,539)|
1,11,12,1,100,0,0,22,0,0,0,-1--1--1,,1|(605,539)|
11,12,48,677,539,6,8,34,3,0,0,1,0,0,0
10,13,Price of Each Product,677,566,43,19,40,3,0,0,-1,0,0,0
1,14,2,1,1,0,0,0,0,64,0,-1--1--1,,1|(471,437)|
1,15,3,1,1,0,0,0,0,64,0,-1--1--1,,1|(612,465)|
12,16,48,468,693,10,8,0,3,0,0,-1,0,0,0
1,17,19,1,4,0,0,22,0,0,1,-1--1--1,,1|(468,594)|
1,18,19,16,100,0,0,22,0,0,0,-1--1--1,,1|(468,658)|
11,19,48,468,626,8,6,33,3,0,0,4,0,0,0
10,20,Present capacity,528,626,52,11,40,3,0,0,-1,0,0,0
1,21,1,8,1,0,0,0,0,64,0,-1--1--1,,1|(420,610)|

MODEL-2
Cost per part=
5

```

~      Dollar/Product
~      |

Daily Demand of Products Quantity=
100
~      Product/week
~      |

Daily holding cost per part=
4
~      Dollars/week
~      With holding Cost in store
~      |

Economic order Quantity= INTEG (
((Fixed Cost Per Order*Daily Demand of Products Quantity)*(1/Daily
holding cost per part\
))^0.5+Finished Goods to Customer,
0)
~      Product/week
~      |

Finished Goods to Customer=
Rate of Demand by customer-Economic order Quantity
~      Product/week
~      |

Fixed Cost Per Order=
200
~      Dollars/week
~      Carrying Cost
~      |

Rate of Demand by customer=
100
~      Product/week
~      |

*****
~      .Control
*****~
~      Simulation Control Parameters
~      |

FINAL TIME = 54
~      week
~      The final time for the simulation.
~      |

INITIAL TIME = 0
~      week
~      The initial time for the simulation.
~      |

SAVEPER =
TIME STEP
~      week [0,?]

```

```

~      The frequency with which output is stored.
|

TIME STEP = 0.25
~      week [0,?]
~      The time step for the simulation.
|

\\ \---// Sketch information - do not modify anything except names
V300 Do not put anything below this section - it will be ignored
*View 1
$192-192-192,0,Times New Roman|12||0-0-0|0-0-0|0-0-255|-1--1--1|-1--1--
1|96,96,100,0
10,1,Economic order Quantity,789,436,43,25,3,131,0,0,0,0,0,0
10,2,Daily Demand of Products Quantity,611,455,58,19,8,3,0,0,0,0,0,0
10,3,Cost per part,378,472,43,11,8,3,0,0,0,0,0,0
10,4,Daily holding cost per part,505,337,55,30,8,131,0,0,0,0,0,0
10,5,Fixed Cost Per Order,751,303,49,19,8,3,0,0,0,0,0,0
12,6,48,1072,437,10,8,0,3,0,0,-1,0,0,0
1,7,9,6,4,0,0,22,0,0,0,-1--1--1,,1|(1007,437)|
1,8,9,1,100,0,0,22,0,0,0,-1--1--1,,1|(886,437)|
11,9,48,947,437,6,8,34,3,0,0,1,0,0,0
10,10,Finished Goods to Customer,947,464,59,19,40,3,0,0,-1,0,0,0
1,11,5,1,1,0,0,0,0,64,0,-1--1--1,,1|(784,371)|
1,12,2,1,1,0,0,0,0,64,0,-1--1--1,,1|(693,464)|
1,13,4,1,1,0,0,0,0,64,0,-1--1--1,,1|(638,365)|
1,14,1,10,1,0,0,0,0,64,0,-1--1--1,,1|(851,505)|
10,15,Rate of Demand by customer,958,583,62,19,8,3,0,0,0,0,0,0
1,16,15,10,1,0,0,0,0,64,0,-1--1--1,,1|(983,528)

```

Model-3

```

Daily demand of Parts=
500/Time required to complete the Parts
~      Products/Minuts
~      |

Machine reliability for Production=
1*Number of machine Required
~      Machines/Minuts
~      |

Number of machine Required= INTEG (
(Daily demand of Parts*1/Machine reliability for Production*1/Time
Required To Complete The Task
),
1)
~      Machines/Minuts
~      |

Time required to complete the Parts=
12.2
~      Minuts
~      |

Time Required To Complete The Task=
1000

```

```

~      Minuts
~      working time per day
|

*****
.Control
*****~
      Simulation Control Parameters
|

FINAL TIME = 100
~      Minute
~      The final time for the simulation.
|

INITIAL TIME = 0
~      Minute
~      The initial time for the simulation.
|

SAVEPER =
      TIME STEP
~      Minute [0,?]
~      The frequency with which output is stored.
|

TIME STEP = 0.5
~      Minute [0,?]
~      The time step for the simulation.
|

\\---// Sketch information - do not modify anything except names
V300 Do not put anything below this section - it will be ignored
*View 1
$192-192-192,0,Times New Roman|12||0-0-0|0-0-0|0-0-255|-1--1--1|-1--1--
1|96,96,100,0
10,1,Daily demand of Parts,956,334,56,22,8,131,0,0,0,0,0,0
10,2,Number of machine Required,830,425,45,30,3,131,0,0,0,0,0,0
12,3,48,602,415,10,8,0,3,0,0,-1,0,0,0
1,4,6,2,4,0,0,22,0,0,0,-1--1--1,,1|(746,415)|
1,5,6,3,100,0,0,22,0,0,0,-1--1--1,,1|(653,415)|
11,6,48,701,415,6,8,34,3,0,0,1,0,0,0
10,7,Machine reliability for Production,701,442,58,19,40,3,0,0,-1,0,0,0
1,8,1,2,1,0,0,0,0,64,0,-1--1--1,,1|(944,403)|
1,9,2,7,1,0,0,0,0,64,0,-1--1--1,,1|(791,486)|
10,10,Time Required To Complete The Task,767,290,71,30,8,131,0,0,0,0,0,0
1,11,10,2,1,0,0,0,0,64,0,-1--1--1,,1|(779,306)|
10,12,Time required to complete the Parts,935,203,59,19,8,3,0,0,0,0,0,0
1,13,12,1,1,0,0,0,0,64,0,-1--1--1,,1|(994,255)|

MODEL-4
Cost of All Parts=
      Total Costof All Parts
~      Dollar/Product
~      |

daily holding Cost=

```

```

Total With holding Cost
~    Dollars/week
~    |

Total Costof All Parts= INTEG (
  (Cost per part*Daily Demand of Products Quantity)-Cost of All
  Parts,
  0)
~    Dollars/week
~    |

Total With holding Cost= INTEG (
  (Daily holding cost per part*Economic order Quantity)*1/2-daily
  holding Cost,
  0)
~    Dollars/week
~    |

Cost per part=
  5
~    Dollar/Product
~    |

Daily Demand of Products Quantity=
  100
~    Product/week
~    |

Daily holding cost per part=
  4
~    Dollars/week
~    With holding Cost in store
~    |

Economic order Quantity= INTEG (
  ((Fixed Cost Per Order*Daily Demand of Products Quantity)*(1/Daily
  holding cost per part\
  ))^0.5+Finished Goods to Customer,
  0)
~    Product/week
~    |

Finished Goods to Customer=
  Rate of Demand by customer-Economic order Quantity
~    Product/week
~    |

Fixed Cost Per Order=
  200
~    Dollars/week
~    Carrying Cost
~    |

Rate of Demand by customer=
  100
~    Product/week
~    |

```

```
*****
.Control
*****~
```

Simulation Control Parameters

```
|
FINAL TIME = 54
~ week
~ The final time for the simulation.
|
```

```
INITIAL TIME = 0
~ week
~ The initial time for the simulation.
|
```

```
SAVEPER =
TIME STEP
~ week [0,?]
~ The frequency with which output is stored.
|
```

```
TIME STEP = 0.25
~ week [0,?]
~ The time step for the simulation.
|
```

\\--// Sketch information - do not modify anything except names
V300 Do not put anything below this section - it will be ignored

*View 1

```
$192-192-192,0,Times New Roman|12||0-0-0|0-0-0|0-0-255|-1--1--1|-1--1--
1|96,96,100,0
10,1,Economic order Quantity,939,445,43,25,3,131,0,0,0,0,0,0
10,2,Daily Demand of Products Quantity,589,409,58,19,8,3,0,0,0,0,0,0
10,3,Cost per part,780,103,43,11,8,3,0,0,0,0,0,0
10,4,Daily holding cost per part,816,332,57,19,8,131,0,0,0,0,0,0
10,5,Fixed Cost Per Order,689,502,49,19,8,3,0,0,0,0,0,0
12,6,48,1300,425,10,8,0,3,0,0,-1,0,0,0
1,7,9,6,4,0,0,22,0,0,0,-1--1--1,,1|(1245,430)|
1,8,9,1,100,0,0,22,0,0,0,-1--1--1,,1|(1085,430)|
11,9,48,1194,430,6,8,34,3,0,0,1,0,0,0
10,10,Finished Goods to Customer,1194,457,59,19,40,3,0,0,-1,0,0,0
1,11,5,1,1,0,0,0,0,64,0,-1--1--1,,1|(755,450)|
1,12,2,1,1,0,0,0,0,64,0,-1--1--1,,1|(759,406)|
1,13,4,1,1,0,0,0,0,64,0,-1--1--1,,1|(873,420)|
1,14,1,10,1,0,0,0,0,64,0,-1--1--1,,1|(1081,399)|
10,15,Rate of Demand by customer,1062,534,62,19,8,3,0,0,0,0,0,0
1,16,15,10,1,0,0,0,0,64,0,-1--1--1,,1|(1142,503)|
10,17,Total Cost of All Parts,750,225,48,26,3,131,0,0,0,0,0,0
1,18,3,17,1,0,0,0,0,64,0,-1--1--1,,1|(737,196)|
1,19,2,17,1,0,0,0,0,64,0,-1--1--1,,1|(635,324)|
12,20,48,447,221,10,8,0,3,0,0,-1,0,0,0
1,21,23,20,4,0,0,22,0,0,0,-1--1--1,,1|(515,221)|
1,22,23,17,100,0,0,22,0,0,0,-1--1--1,,1|(643,221)|
11,23,48,579,221,6,8,34,3,0,0,1,0,0,0
10,24,Cost of All Parts,579,240,53,11,40,3,0,0,-1,0,0,0
```

10,25,Total With holding Cost,960,268,48,30,3,131,0,0,0,0,0,0
 12,26,48,1267,269,10,8,0,3,0,0,-1,0,0,0
 1,27,29,26,4,0,0,22,0,0,0,-1--1--1,,1|(1197,269)|
 1,28,29,25,100,0,0,22,0,0,0,-1--1--1,,1|(1067,269)|
 11,29,48,1132,269,6,8,34,3,0,0,1,0,0,0
 10,30,daily holding Cost,1132,288,56,11,40,3,0,0,-1,0,0,0
 1,31,25,30,1,0,0,0,0,64,0,-1--1--1,,1|(1066,229)|
 1,32,4,25,1,0,0,0,0,64,0,-1--1--1,,1|(865,278)|
 1,33,1,25,1,0,0,0,0,64,0,-1--1--1,,1|(988,360)|
 1,34,17,24,1,0,0,0,0,64,0,-1--1--1,,1|(650,190)|

Appendix E Mapping Important Relationship of Selected Ram-up Model Problems

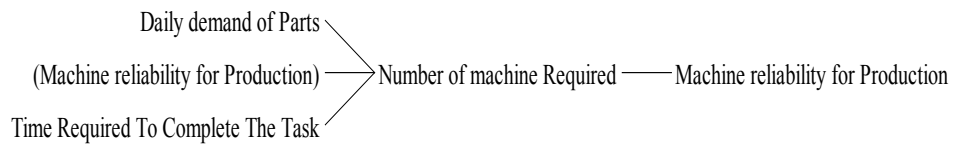
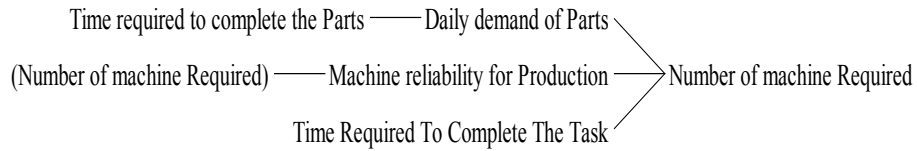
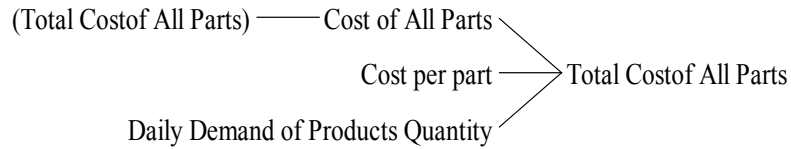
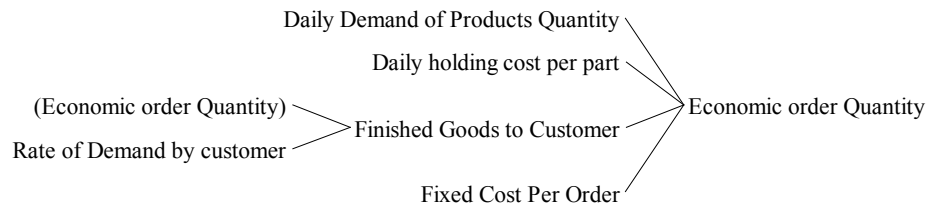

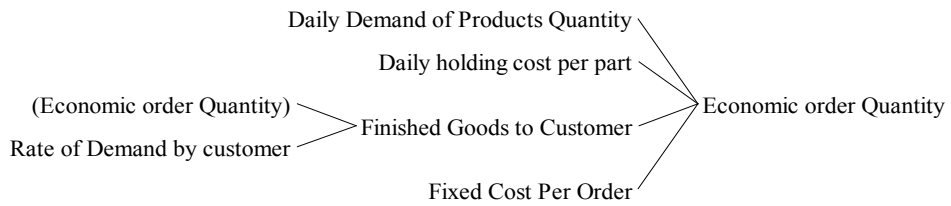
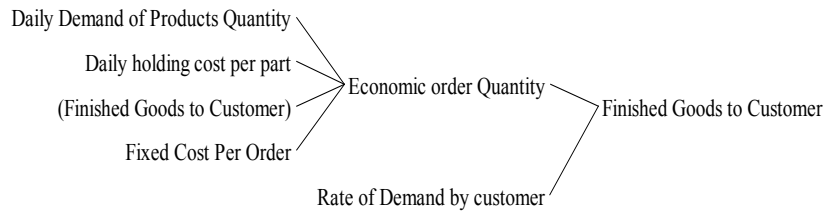
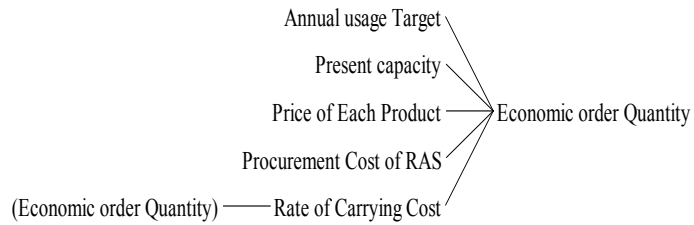
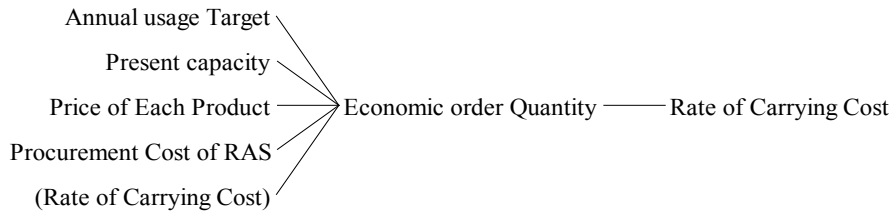
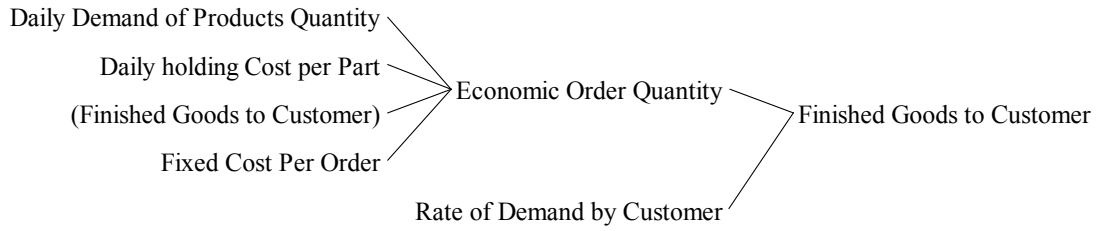

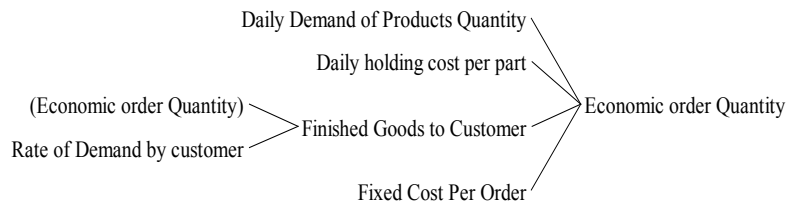
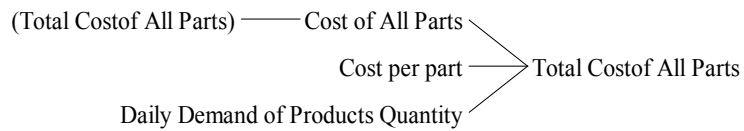
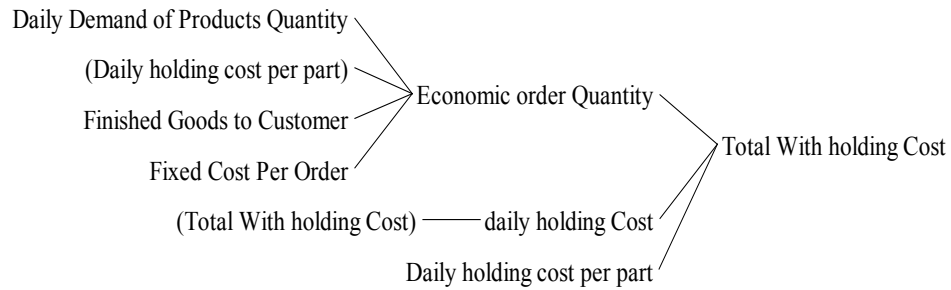
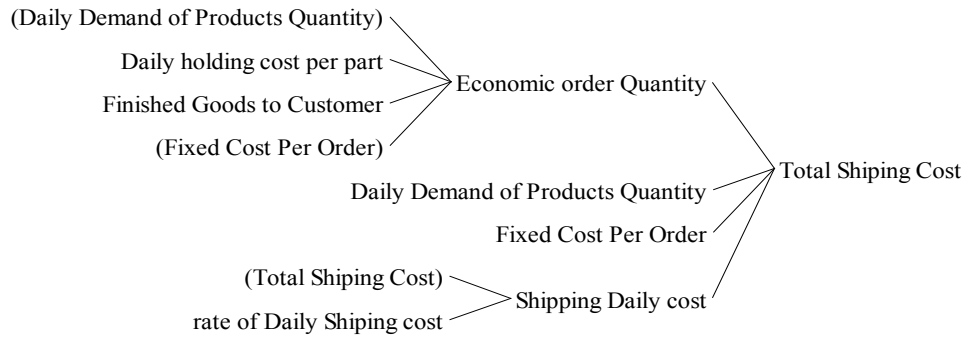
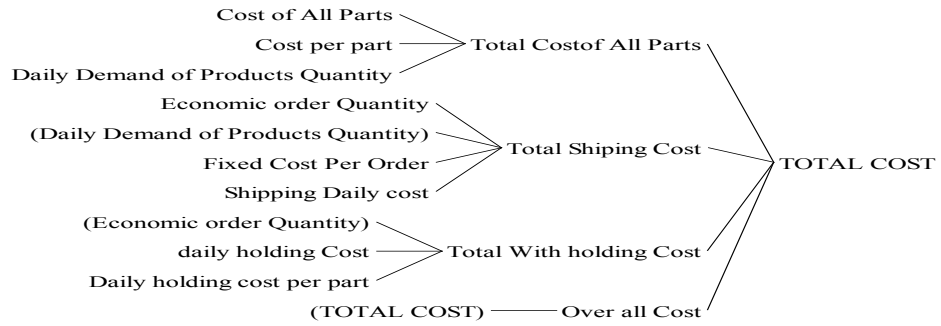

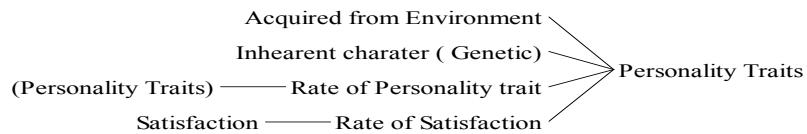
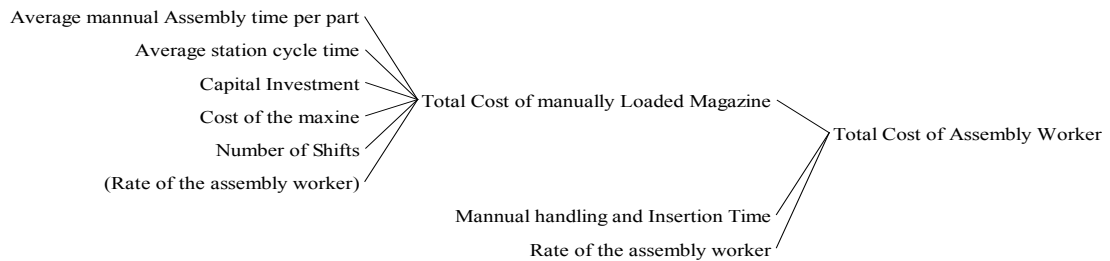
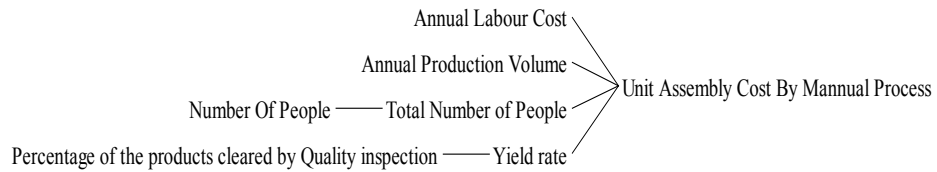
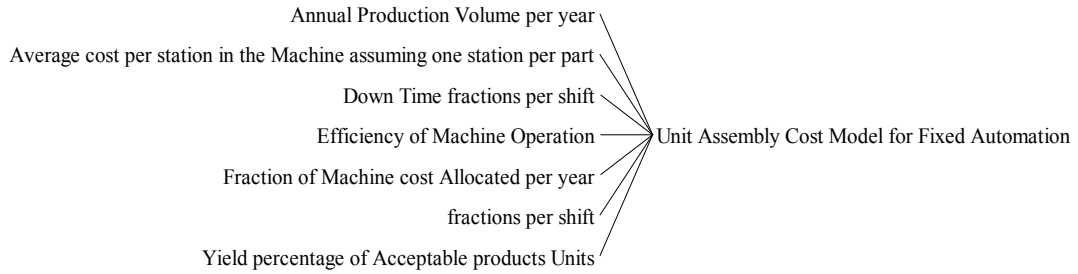
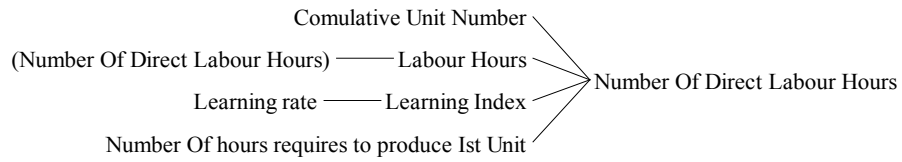

Appendix F Key Words Based Literature Search

The Following key words search which have been made and results are in matrices format prepared for ease of readers to follow their trail of references for further interest. These key words are as such: Life cycle of product, Frequency of ramp-up, Commonality of the products, Plate form technology, Product Complexity, Product variety, Product architecture and technology, Production method and technology used, and Industrial Set-up. Large numbers of papers have been found in literature which has very broad spectrum of research. But unfortunately there is dearth of meaningful related papers to our ramp up SOS based sociotechnical research focus. In case of each of key words there exist number of papers out of which very few were selected and their notable contribution is presented in the tabulated form in this Appendix F for readers. Business databases Scopus, Compendix and Inspec were used for search mostly with specific key words as such:

Key Word Frequency of Ramp Up Related Literature

Serial No	Author Name/Year	Methodology	Contribution to research
1	Dombrowski, U. et al(2011)	Descriptive	This paper discusses the frequency of production with making relative link with ramp up. It advocates the lean production system by giving description to lean ramp up product development.
2	Dombrowski, U. et al(2009)	Descriptive	This paper describes the ramp up scenario in the small manufacturing enterprise. It provides the organization model developed and discusses the lean ramp-up process.
3	Swanekamp, R. (1995)	Experimental	This paper is experimental and is based upon the practical of a low aspect ratio torus experiment (LATE) device.
4	Musch, T. et al. (2000)	Experimental	In this paper a concept of a dual loop synthesizer is presented based on fractional divider techniques which is used for measuring highly linear analog frequency ramps. A (VNA) Vector Network Analysis is performed to obtain more quick measurement.

Key Word Production Yield Related Literature

Serial No	Author Name/Year	Methodology	Contribution to research
1	Baltagi, Y. (2011)	Descriptive	This paper describes the failure analysis on the bit map whose production yield is impacted by the analysis.
2	Pearn, W.L. (2010)	Descriptive	This paper describes the convolution method for production yields and provides useful estimates and information about the sample size.

Key Word Commonality of Plate Form Related Literature

Serial No	Author Name/Year	Methodology	Contribution to research
1	Liu, Z. et al. (2010)	Descriptive Mathematical	In this paper the optimization method is applied to make a trade off between the commonality configuration, and a framework is also proposed
2	Liu, Z. et al. (2011)	Descriptive Mathematical	This paper describes the multi plate form based product family configuration using commonality index which is coupled with varieties of the design and production variation for having increased manufacturing efficiency.
3	Nugroho, Y.K. (2011)	Descriptive Mathematical	This paper discusses the build to order scenario in which product commonality and simulating by means of model to represent supplier and manufacturer communication.

Key Word Product Life Cycle Related Literature

Serial No	Author Name/Year	Methodology	Contribution to research
1	Sanayei, A. et al. (2012)	Theoretical	This paper considers control related actions management, along with the product launch time, observed budget constraints, and sales volume, as well as demand and market requirements during the product life cycle. This paper is partly theoretical and partly descriptive.
2	Lee, J. et al. (2010)	Deterministic approach	This paper emphasizes the need for the data of the product to be managed for the whole Life

			cycle of the product. Where a deterministic approach has been followed.
3	Xiao-pu Jiang et al. (2011)	Deterministic	This paper is deterministic and discusses the role of strategy in product life cycle which for the writer includes many things, such as marketing strategy, development strategy and advertising strategies.
4	Tkachenko, N.; (2010)	Deterministic	It describe the optimization technique for the quality and associated values.

Key Word Commonality Of Production Related Literature

Serial No	Author Name/Year	Methodology	Contribution to research
1	Thomas, L.C. et al. (2003)	Mathematical	In this paper a Markov decision model is used to model production and inventory for analysis
2	Wazed, M.A. et al. (2011)	Mathematical Descriptive	In this paper process commonality of the production is introduced in the model by means of which the cost is being analyzed due to effects of process commonality, capacity and scheduling requirement under uncertainties.
3	Wazed, M.A. et al. (2010)	Descriptive	In this paper a mathematical model is introduced for managing effects of commonality in multi stage system.
4	Shamsuzzoha et al.(2009)	Descriptive	In this paper the commonality value and its effect on the product variety management is being made by using the agile supply & demand.
5	Tsubone, H. et al. (1994)	Descriptive	This paper describes the component parts commonality and process flexibility in terms of production and assembly process.

Key Word Commonality of Plate Form Related Literature

Serial No	Author Name/Year	Methodology	Contribution to research
1	Liu, Z. et al. (2011)	Descriptive Mathematical	In this paper the optimization method is applied to make a trade off between the commonality configuration, a frame work is also proposed

2	Liu, Z. et al. (2010)	Descriptive Mathematical	This paper describes the multi plate form based product family configuration using commonality index which is coupled with varieties of the design and production variation for having increased manufacturing efficiency.
3	Nugroho, Y.K. (2011)	Descriptive Mathematical	This paper discusses the Build to order scenario in which product commonality and simulating by means of model to represent supplier and manufacturer communication.

Key Word Scalability Of Production Related Literature

Serial No	Author Name/Year	Methodology	Contribution to research
1	Deif, A.M. et al. (2006)	Descriptive Analytical	This paper addresses the reconfigurable manufacturing issues and a scalability controller is proposed with dynamic modeling for analysis and to have improved results.
2	Kampker, A. et al.(2012)	Theoretical	This paper advocates the fact that the cost and quality is not the only factors to be rely upon for production of electric cars but scalability issues may be focused as well with respect to the customer value.

Key Word Product Variety Related Literature

Serial No	Author Name/Year	Methodology	Contribution to research
1	Stablein, T. (2011)	Descriptive	This paper suggest a novel way to measure the product variety by using the average repetition ratio and related Pareto curve.
2	Van Iwaarden, J. et al (2012)	Descriptive	This paper describes the effect of variety and shorter life cycle control by means of quality through a model which describes contextual elements are important
3	Luh, Ding-Bang et al.	Descriptive	This paper discusses the design process

	(2011)		in concurrent engineering, the planning model is based on global and local planning which can be utilized for better product variety management.
4	Roy, R. et al (2011)	Descriptive	This paper describes a frame work which is focused on cost and revenue based analysis for addressing the issue of making decision on variety and complexity exists in design.

Key Word Product Complexity Related Literature

Serial No	Author Name/Year	Methodology	Contribution to research
1	Orfi, N. et al. (2011)	Descriptive	Life cycle complexity measuring is discussed and five critical area based strategy is developed for analysis to manage life cycle based complexity of product. A frame work is described as supporting tool.
2	Felipe, J. (2012)	Descriptive	This paper gives the interesting co relation between the complex product market development in rich economies and visa vises.
3	Campbell, M., (2010)	Descriptive	This paper describe the yield in production of the semi conductors and related test development with the cost analysis which is essential for the sustainable semi conductors
4	Closs D.J. et al. (2010)	Analytical	This paper describes a simulation model which is used to test the theory of configuration capacity and inventory level direct impact on performance.

Key Word Ramp Up Production Related Literature

Serial No	Author Name/Year	Methodology	Contribution to research
1	Lanza Gisela, (2012)	Descriptive	This paper provides an optimization for the man power needed to cope with the production ramp up task while forecasting the dynamic variable which enables the organization to simulate economically viable for management.
2	Glock, C. H. et al. (2012)	Pragmatic Practical	The model presented in this paper is focused upon the learning and growth

			of the demand by lowering production rate and the work force deployed to the task of production.
3	Nau, B.,R. et al. (2011)	Descriptive	This paper discusses the need for deploying the hybrid methodology to sustain the objective of implementing the technology at the right time for suitability in to existing manufacturing.
4	Doltsinis, S. et al. (2013)	Descriptive	This work proposes a systematic framework for data preparation, ramp-up formalization, and performance measurement. A model for defining the ramp-up state of a system has been developed in order to formalize and capture its condition.

Key Word Commonality of Production Related Literature

Serial No	Author Name/Year	Methodology	Contribution to research
1	Thomas, L.C. et al. (2003)	Mathematical	In this paper a Markov decision model is used to model production and inventory for analysis
2	Wazed, M.A. et al. (2011)	Mathematical Descriptive	In this paper process commonality of the production is introduced in the model by means of which the cost is being analyzed due to effects of process commonality, capacity and scheduling requirement under uncertainties.
3	Wazed, M.A. et al. (2010)	Descriptive	In this paper a mathematical model is introduced for managing effects of commonality in multi stage system.
4	Shamsuzzoha (2009)	Descriptive	In this paper the commonality value and its effect on the product variety management is being made by using the agile supply & demand.
5	Tsubone, H. et al. (1994)	Descriptive	This paper describes the component parts commonality and process flexibility in terms of production and assembly process.

Appendix G List of Publications and Presentations

- 1) Ali-Qureshi, Z. and ElMaraghy, W.H.(2014), " Procurement of Reconfigurable Assembly System a Justification for Effective Production Ramp-up Planning", The 6th CIRP Conference on Industrial Product-Service Systems (IPSS-2014), Windsor, Ontario, Canada.
- 2) Ali-Qureshi, Z. and ElMaraghy, W.H. (2011)," Sustainable System Risk Analysis: a Triple Bottom Line Approach", The 4th International Conference on Agile, Reconfigurable and Virtual Production (CARV-2011), Montreal, Canada.
- 3) Ali-Qureshi, Z. (2011)," System of Systems based Complexity Analysis for New Product Design", The ASME International Design Engineering and Technical Conference, (IDET- 2011), Washington D.C., USA.
- 4) Ali-Qureshi, Z. (2011),"System of Systems based Sustainable Vehicle design for Transportation System", ASME`s International Design Engineering and Technical Conference, (IDET- 2011), Washington D.C., USA.
- 5) Ali-Qureshi, Z. (2011) “Reverse Logistic Planning and Product Take Back for Sustainable Process and Product Design” *SAE International Congress-2011*, Detroit, MI, USA.
- 6) Ali-Qureshi, Z. (2010), “Top Down Life Cycle Analysis based Hybrid design approach for New Product Design”, ASME International Design Engineering and Technical Conference, (IDET-2010), Montreal, Canada.
- 7) Ali-Qureshi, Z. (2010), "Dynamic Role of Reverse Logistic Cycle with in Life Cycle Analysis for Sustainability", The 10th AEES Ecological Engineering Society meeting held at 17th World Congress of the International Commission of Agricultural and Bio-System Engineering, Quebec city, Canada.

- 8) Ali-Qureshi, Z. (2010), "Single use Carrier Sacs and Reverse Logistic: A Life Cycle Analysis based Approach", Published by the American Society of Agricultural and Biological Engineers (ASABE), Pittsburgh, Pennsylvania, USA.
- 9) Ali-Qureshi, Z. (2010), "New Product Design Sustainable Decision Making in Lean manufacturing System", Published by 4th Canadian Forum on the Life Cycle Management of Products and Services Conference, Montreal, Canada.
- 10) Ali-Qureshi, Z. (2009), "Comparison of Sustainable Design of Green Energy System from Hydrogen and Natural Gas of Bio-Mass", Published by the American Society of Agricultural and Biological Engineers, (Bio-ENERGY-2009) Bellevue-Seattle, Washington, USA.
- 11) Ali-Qureshi, Z. (2009), "Energy Analysis of Sustainable NPD of Green Power Parks", Published by International Association of Scientific & Technical Development (IASTED), Environmental Management and Engineering (EME-2009) Banff-Calgary, Alberta, Canada.
- 12) Ali-Qureshi, Z. (2008), "Green Manufacturing of Electricity for Stationary Industrial Applications", ASME International Manufacturing Science and Engineering Conference with JSM's Japan Society of Manufacturing Engineering International Conference on Materials and Processing (MSEC-2008), Evanston-Chicago, IL, USA.

VITA AUCTORIS

NAME: Zulfiqar Ali Qureshi.

PLACE OF BIRTH: Peshawar City, Khyber Pakhtun Khawa (KPK),
(North West Frontier Province), Pakistan.

YEAR OF BIRTH: 1967

EDUCATION: Centennial Higher Secondary School,
Government High School No-2,
Peshawar City, KPK, Pakistan .(1982)

Associate Degree, Diploma of Associate Engineer,
Mechanical (Manufacturing) Technology.
Government College of Technology,
Peshawar City, KPK, Pakistan.(1987)

B.Sc. Mechanical Engineering,
University of Engineering,
Peshawar City, KPK, Pakistan.(1992)

LL.B. (Bachelors of Laws and Legislations),
University of Peshawar,
Peshawar Law College,
Peshawar City, KPK, Pakistan.(1998)

M.A. Political Science,
University of Peshawar,
Peshawar City, KPK, Pakistan.(2000)

M.Sc. Information Technology,
University of Gomal @ Peshawar Campus,
Peshawar City, KPK, Pakistan.(2002)

Masters in Mechanical Engineering,
University of Alberta,
Edmonton, Alberta, Canada.(2006)

Ph.D. Candidate,
Industrial & Manufacturing Systems Engineering,
University of Windsor, Ontario, Canada.
(2013-2014).