

1978

The ancient svastika.

Charles William. Blewett
University of Windsor

Follow this and additional works at: <http://scholar.uwindsor.ca/etd>

Recommended Citation

Blewett, Charles William., "The ancient svastika." (1978). *Electronic Theses and Dissertations*. Paper 3760.

This online database contains the full-text of PhD dissertations and Masters' theses of University of Windsor students from 1954 forward. These documents are made available for personal study and research purposes only, in accordance with the Canadian Copyright Act and the Creative Commons license—CC BY-NC-ND (Attribution, Non-Commercial, No Derivative Works). Under this license, works must always be attributed to the copyright holder (original author), cannot be used for any commercial purposes, and may not be altered. Any other use would require the permission of the copyright holder. Students may inquire about withdrawing their dissertation and/or thesis from this database. For additional inquiries, please contact the repository administrator via email (scholarship@uwindsor.ca) or by telephone at 519-253-3000ext. 3208.



National Library of Canada

Cataloguing Branch
Canadian Theses Division

Ottawa, Canada
K1A 0N4



NOTICE

The quality of this microfiche is heavily dependent upon the quality of the original thesis submitted for microfilming. Every effort has been made to ensure the highest quality of reproduction possible.

If pages are missing, contact the university which granted the degree.

Some pages may have indistinct print especially if the original pages were typed with a poor typewriter ribbon or if the university sent us a poor photocopy.

Previously copyrighted materials (journal articles, published tests, etc.) are not filmed.

Reproduction in full or in part of this film is governed by the Canadian Copyright Act, R.S.C. 1970, c. C-30. Please read the authorization forms which accompany this thesis.

**THIS DISSERTATION
HAS BEEN MICROFILMED
EXACTLY AS RECEIVED**

Bibliothèque nationale du Canada

Direction du catalogage
Division des thèses canadiennes

AVIS

La qualité de cette microfiche dépend grandement de la qualité de la thèse soumise au microfilmage. Nous avons tout fait pour assurer une qualité supérieure de reproduction.

S'il manque des pages, veuillez communiquer avec l'université qui a conféré le grade.

La qualité d'impression de certaines pages peut laisser à désirer, surtout si les pages originales ont été dactylographiées à l'aide d'un ruban usé ou si l'université nous a fait parvenir une photocopie de mauvaise qualité.

Les documents qui font déjà l'objet d'un droit d'auteur (articles de revue, examens publiés, etc.) ne sont pas microfilmés.

La reproduction, même partielle, de ce microfilm est soumise à la Loi canadienne sur le droit d'auteur, SRC 1970, c. C-30. Veuillez prendre connaissance des formules d'autorisation qui accompagnent cette thèse.

**LA THÈSE A ÉTÉ
MICROFILMÉE TELLE QUE
NOUS L'AVONS REÇUE**

© Charles William Blewett 1978
All Rights Reserved

001201

THE ANCIENT SVASTIKA

by

Charles William Blewett

A Thesis
Submitted to the Faculty of Graduate Studies
through the Department of Religious Studies
in Partial Fulfillment of the Requirements
For the Degree of Master of Arts at
The University of Windsor

*Windsor, Ontario, Canada

1978

ABSTRACT

"The Ancient Svastika"

This thesis reconsiders the evidence for the traditional scholarly opinion that the ancient svastika was originally an Indo-European symbol for the sun. It rejects that opinion, arguing that the svastika originated before the coming of the Indo-European cultures and that the svastika is a symbol of the centre of the world, the axis mundi.

Chapter 1 studies the relationship which exists between the word, which is Indo-European, and the symbol which is not. The svastika is defined in that chapter, and its form is analyzed.

Chapter 2 is directly about the archaeological evidence against the Indo-European theory. The chronology of the symbol is matched against that of the Indo-Europeans in order to show that they were not instrumental in the use of the symbol in northern Mesopotamia (6th millenium B.C.) or in the early levels of Troy (3000 B.C.).

In the process a suggestion is put forward on the ultimate origins of the symbol among prehistoric weavers, on the question of diffusion versus independent invention, and on the need for further research into specific areas of

the history of the svastika in prehistoric times.

Chapter 3 deals with the meaning of the symbol, with the confusion of scholars over that meaning, and with the reasons for that confusion. It centres on the sun-symbol theory and offers a criticism of that view. Finally it suggests that meaning is the wrong word to apply to the significance of the svastika, and offers in place of meaning the concepts of role and complex of symbols.

The last chapter discusses the role of the svastika in prehistoric cosmography, and relates the concept of the centre to early weaving and astronomy.

The Conclusion weaves together the various strands to clarify the implications of such a view of the svastika-- implications pertinent not only to the antique past, but also to our own future.

Seven Appendices and a Bibliography follow the thesis.

TABLE OF CONTENTS

INTRODUCTION	1
CHAPTER 1--The Svastika: Sign, Symbol, and Reality	
Introduction	2
The Sign	3
The Symbol	8
Summary	15
Notes	17
CHAPTER 2--The Roots of the Svastika	
Introduction	27
Samarra	29
Interlude in Iran	34
The Western Branch	37
The Svastika in India.....	42
Summary	46
Notes	48
CHAPTER 3--Interpretations of the Svastika	
Introduction	58
The Solar Svastika	59
The <u>Role</u> of the Svastika	66
Summary	74
Notes	76
CHAPTER 4--The Svastika: A Symbol of the Centre	
Introduction	81
The Symbolism of Space	85
Weaving and the Svastika	95
Summary	103
Notes	107
CONCLUSION	114
Notes	123
APPENDIX 1--The Morphological Spectrum	124
APPENDIX 2--Prehistoric Svastikas	131
APPENDIX 3--Samarran Sites and Indo-European Migrations	135
APPENDIX 4--D'Alviella's Plate II / Tree of Life Symbols	137
APPENDIX 5--Trojan Spindle-Whorls.....	140
APPENDIX 6--Lothal and West Asian Trade (Chart) ..	147
APPENDIX 7--Indo-European Pottery Design	148
Notes	150

SELECTED BIBLIOGRAPHY	151
VITA AUCTORIS	160

ACKNOWLEDGEMENTS

I owe more than can be recounted here to the entire department of Religious Studies at the University of Windsor. Their doors, like their hearts and minds, were always open to students like myself, who had to know. The openness, honesty, and diligence with which they taught, made it possible for me to pursue my course of studies most pleasantly and satisfactorily. I thank them all.

In particular I would like to single out Dr. Roy C. Amore who directed this Thesis. From the first day to the last he gave freely much valuable assistance, not only in regard to this Thesis, but personally and professionally as well. I shall always be deeply grateful for his attention and enthusiasm.

To Dr. M. Mehta of the Asian Studies Department at the University of Windsor, I must also profess my admiration, gratitude, and indebtedness. His love of teaching, patience, and poetic sensitivity shall always inspire me. I thank him for all that, and for the honor he granted me by being the external reader of the thesis.

These acknowledgements would be most incomplete if I were to neglect to thank publicly Professor Edward Crowley, second reader and Head of the Department. He is largely res-

possible for whatever small successes I have garnered for myself during my years with the Department. Always available, ever-helpful, he set an example of personal and professional behavior that cannot be commended highly enough. Much of the warmth and progressive-minded openness that characterize the Religious Studies Department are directly due to the impact which his personality had on all of us who know him. I owe him a special thank-you for filling a gap on the committee caused by an illness at the last moment.

To the entire staff of the Library at the University, and especially to Barbara Cunningham (whose willingness to help was exceeded only by the warmth of her personality and her gentle good humour), I gratefully acknowledge my debt. Thank you.

But the people to whom I owe most are the members of my own family: Wesley and Becky who gave up for me a very precious thing--a piece of their childhood; and Jeni, my good friend (and wife) who never stood in the way, gave up much, and patiently acted as sounding board for me. Without the work, sustaining love, and selfless dedication of these three, this Thesis would have remained forever nothing more than a dream. I dedicate it to them.

INTRODUCTION

The Nature of the Study

What began three years ago as a casual affair has now become this thesis. It is a study of the svastika, its roots and its meaning. It includes archaeological findings, philosophy, religion, and linguistics. Nor have anthropology and psychology been overlooked since it is in man himself that that meaning and those roots are finally to be found.

Symbols have a way of linking worlds together, and of breaking them apart. Such a symbol is the svastika. It has been with us for more than 75 centuries--longer than man has been living in what could be called cities. Man has used the svastika as a symbol for a greater portion of time, than he has used the wheel. The svastika is old, very old.

It is also very modern. In this century the svastika emerged from its obscure past to manifest itself in the German psyche with all the force of a titanic whirlwind. And in our own time it stirs our soul to hatred and repugnance--and guilt. At the same time, for millions of people, it is a symbol of prosperity, of fortune, and auspicious beginnings. The polarization of the svastika into a portent of blessedness and a symbol of evil has posed the question which this thesis seeks to answer:

CHAPTER 1

The Svastika: Sign, Symbol, and Reality

I. Introduction

Kālidāsa viewed the union of Śiva and Śakti as the source of life and understanding symbolized by the relationship between word and meaning. In the first verse of the Raghuvamśa he sought the aid of these World-Parents in that attempt to forge a union of substance and form in his writings.¹ Likewise, I should begin this work with a plea, not for their aid, but for their indulgence. I desire to sunder the holy union.² I wish to divorce word from meaning in order to better understand the nature of both. Thus:

O Noblest Svasti with abundant riches, who comes
to what is good by distant pathways,--
May you at home and far away preserve us,
and dwell with us under the gods' protection.
(Griffith, RgVeda, 10. 63. 16)

In this passage svasti means "the Goddess of Prosperity." From that, in turn, came our English word swastika. It means the symbol, , which in the Indian tradition is the emblem of Ganesa, the elephant-headed god. Both he and the svastika are symbols of auspiciousness, prosperity, and all beginnings.³ Invoking Ganeśa, or inscribing the svastika, before beginning any enterprise ensures a happy outcome and brings good luck.

May he now assist me to remove the first of the ob-

stacles which prevent us from obtaining a clear view of the significance of his emblem: the veil of words that obscures reality. Svasti!⁴

II. The Word⁵

The year 1933 is important to the study of the svastika. It was in that year that the svastika-flag first flew over the Reichstag;⁶ that the German press first began to take note of it;⁷ and that the word was first entered in English-language dictionaries.⁸ In the year that followed Jorg Lechler published a revised edition of his work on the svastika. In it he remarked, "The Hakenkreuz (svastika) has in our own time once again become a living symbol."⁹ He was quite right, as far as Germany was concerned, but not for the East, for India and those countries in which the svastika had long been a living symbol. Because of its Eastern vitality, the resurrected Hakenkreuz kept svastika for its name.

But svastika is not the only word for the symbol. The German Hakenkreuz (lit., "hooked cross") has already been mentioned. In England, it has been known as fylfot ("full-footed") since Anglo-Saxon times.¹⁰ The French have many names for it, including Croix Swasticale, Croix Gammée, and Gammodian.¹¹ The Count Goblet d'Alviella used

this last name in his work, The Migration of Symbols,¹² but the majority of writers, past and present, preferred the term svastika.

The word as it is known today was created by the addition of the suffix -ka to the root word svasti (lit., "it exists well").¹³ Suffixation apparently took place at the close of the Vedic period, or in the Upaniṣadic era. Four reasons point to this conclusion:

- 1.) There is no mention of svastika in the Vedas.
- 2.) Svasti occurs frequently in the Vedas.
- 3.) Yāska, the 8th century B.C. commentator, does not mention svastika in his writings, though he does mention svasti.¹⁴
- 4.) Pāṇini, in the 4th century B.C., does mention the svastika for the first time.¹⁵

Pāṇini lists the svastika as one of the marks (lak-sana) used to denote the ownership of cattle. Other unnamed laksana-s were used in the same period as the emblems of the various families, Vedic schools, and even states. It seems evident that by Pāṇini's time the svastika was part of a series of marks designating social divisions. Beyond this, we can only guess at the significance of the svastika during its early period.

Prior to Pāṇini's time, svasti was an efficacious word used in Vedic ritual as an address to the gods.¹⁶ As

such, it was an holy word appropriate for undertaking new works, just as svastika is today. It was also said to be the name of a R̥ṣi, a Goddess (of prosperity), and was used in the sense of a warm greeting, i.e., "Hail!"¹⁷

As the Vedic period wore to a close, the excessive ritualism of Brahmanas gave way to the speculative and secretive philosophy of Upaniṣads. In the first half of the 1st millenium the trend toward the Aryanization of India reversed itself. Heterodox religious forms arose and began to re-assert practices which had been submerged. This was the character of the time between the writings of Yaska and Pāṇini, when svasti became svasti-ka, and when Jainism and Buddhism revered the symbol.

Early Buddhist literature is full of references to fortune-telling by marks on the body--a practice forbidden to the Vedic priests.¹⁸ It may well have been just this forbidden practice that the Venerable Asita performed when the infant Siddhartha was brought before him:¹⁹

But when he saw the Prince the old man cried
 'Ah, Queen, not so!' and thereupon he touched
 Eight times the dust, laid his waste visage
 There, saying, 'O babe! I worship! Thou art he!
 I see the rosy light, the foot-sole marks,
 The soft curled tendril of the Svastika,
 The sacred primal signs thirty and two,
 The eighty lesser tokens. Thou art Buddh,
 And thou wilt preach the Law and save all flesh.

In this legend of the Buddha the svastika appears as a mark of established significance in an anti-Vedic practice.

familiar to Buddhists. Jainists, too, were familiar with the sign.²⁰ According to the Ākārāṅga-Sūtra, II. 15.2, the svastika figures also in the life of of the last of the Tirthankaras, Mahāvīra (A contemporary of Buddha).

the Venerable Ascetic Mahāvīra descended from the great Vimana (palace), the All-victorious and All-prosperous Pushpottara, which like the Lotus among the best (and highest flowers), and like Svastika and Vardhamanaka amongst the Celestial Regions.

Other Jainist usages of the svastika include the claim that it is the emblem of the 7th Tirthankara, it is one of the eight auspicious symbols, and the foremost sign of its devotees.²¹

The anti-Vedic, or heterodox, associations of the symbol contrast starkly with the Sanskrit (Aryan) history of the word. This suggests that the sign and the symbol were separate entities prior to the 8th-6th centuries B.C., that the svastika was part of the folk-tradition of the indigenous and prakrit-speaking peoples of India, and that it became associated with svasti during the formulation of Classical Sanskrit. This hypothesis is borne out by the fact that the symbol was a part of the symbolic idiom of the pre-Aryan Indus Valley civilization. One seal from Mohenjo-Daro depicts a svastika flanked by an elephant,²² an association which is reminiscent of its modern use by the Buddhists of Sri Lanka to adorn the ear-flaps of Parade elephants.²³ Hinduism, as well, preserves this ancient as-

sociation of elephant and svastika in the figure of Ganesa, whose emblem is the svastika and whose head is that of an elephant.

N. P. Gune would have us believe that the Aryans were already familiar with the svastika.²⁴ At a time roughly contemporaneous with the "fall" of the Indus Valley (c. 1500 B.C.), he asserts, the Mittani knew the svastika as an "auspicious sign."²⁵ But Gune fails to make clear if they knew the word, the symbol, or both. It seems very unlikely that the Indo-European (hereafter abbreviated, I-E) Mittani knew the word since it was not formulated until the 1st millenium B.C., in which case Gune is going beyond the evidence in asserting that the symbol was "auspicious." Whatever are the facts of this case, it clearly demonstrates the need to keep the word and the symbol clearly separated.

More meanings came to be attached to the word, in India after the time of Pāṇini. In a 5th century A.D. astrological work, Brhad Samhita, the svastika is called "a kind of building."²⁶ And in the 15th century the Goladīpikā of Parameśvara uses svastika to mean the simple cross²⁷—a usage which is common in modern Sanskrit dictionaries. For instance:

a kind of bard; any lucky or auspicious object; a bandage in the form of a cross; the crossing of the hands on the breast; a dish; a kind of cake; the crossing of four roads; a triangular symbol made of ground rice; garlic; a libertine; a mansion or a

temple;²⁸ sitting with crossed legs;²⁹ making a sign like a cross.³⁰

English-Sanskrit dictionaries list svastika as the Sanskrit word for "cross," and Buck's Dictionary of I-E Synonyms³¹ has no Sanskrit entry for the concept of cross.³²

The history of the word svastika shows that it has undergone a series of transformations since svasti was first used in Vedic times, that it has always been a word of holiness in the Indian religious tradition, and that it was joined with the non-Vedic symbol only after the Vedic period.

Svastika is now a word with quite different connotations to most of the Western world. To many it has become "the most hated symbol in all of mankind."³³ It is indeed an ironic twist of fate that the all-auspicious svastika has become the symbol of the 20th century German neo-Paganism and racism, that the "hooked cross" has become the "twisted cross."³⁴ As a symbol of Hitler's vision of the "victory of Aryan man," the svastika imparted the impetus of its past history to the Nazi mission where it served to focus and direct the will of those devoted to the cause. It was, in the words of Conrad Heiden, "a lucky find."³⁵

III. The Symbol

In view of the radical dichotomy that exists now

between the eastern and western views of the svastika-as-a-symbol, it is time to investigate its past meanings and to re-assess its significance. That is no simple task. With more than 8000 years of historical and prehistorical existence behind it, the svastika is one of the oldest symbols of man. Its distribution is not limited to Germany and the Indian sub-continent, but is virtually world-wide. It is time that someone took on the task which Mircea Eliade described as "the obligation of the religious historian."³⁶ That obligation is to understand and restore to the svastika "all the meanings it may have had in the course of its history."

Before that can be done successfully the symbol must be properly defined.³⁷ But even that process is not without its difficulties. Too narrow a definition can strangle the study and result in an equally narrow set of conclusions. On the other hand, a definition which is overly-broad will include material which can mislead the study. The two major works on the svastika, Thomas Wilson's and Count d'Alviella's violate both of these principles.

Wilson begins his discussion of the symbol with a rigid explicit definition:³⁸

The bars of the normal svastika are straight, of equal thickness throughout, and cross each other at right angles, making four arms of equal size, length, and style. Their peculiarity is that all the ends are bent at right angles and in the same direction, right or left.

Compare this with that given by d'Alviella:³⁹

that form of the cross whose extremities are bent back at right angles, as if to form four gammas joined together at the base.

Both of these definitions restrict the svastika to those two forms given as figures 1 and 2 of my Appendix 1. Yet both authors describe the curvilinear svastika (figure 5, Appendix 1) as a svastika, and yet both describe the forms found on figure 81 of Appendix 1 as svastikas. D'Alviella gathers together a number of svastika-symbols on his Plate II (my Appendix 4, figures 1-23) even though many of them are outside the limits of his own definition.⁴⁰ Both Wilson and d'Alviella describe so many questionable forms as svastikas that I wonder why they bothered to define the symbol at all. Clearly, they both rely on another more inclusive--almost formless--implicit definition. As a result forms are included in the discussion which bear little resemblance to the svastika, and which materially affect the conclusions reached.

Clearly the svastika cannot be limited to the forms covered by the explicit definitions given. It is more complex than that. More than 80 centuries of use have led to the development of a spectrum of forms which are not only geometrical, but are elaborate, abstract, and representational as well.⁴¹ There has to be some clear method of determining the outer limits of the morphological spectrum of the

svastika-as-a-symbol.

The key to that method is the intention of the form. Only those figures which are intentionally meant to be svastikas are pertinent to the study of the symbol. The rest are merely accidental or coincidental. There can be no symbol if there is no intention.⁴² No object may be admitted to that class of objects called symbol unless it exists both phenomenologically and intentionally. Phenomenologically, by reason of its being an experience, and intentionally, by reason of its being made a symbol. Such an object is freed of the constraints of history. That is to say, it is not limited to a strictly historical existence and understanding. It has a transhistorical dimension as well which stems from the intentional consistency of its form. Only through this consistency of form is it possible to study the connection between the Trojan svastika and the German Hakenkreuz.⁴³ I call this factor the morphology of the svastika.⁴⁴

The svastika, like any graphic symbol (circle, square, triangle, spiral), communicates visually. They speak for themselves through the inviolability of their unique forms. Two messages are imparted. The first confronts the human psyche with the pure perception of form. The second speaks of the dynamic qualities of the form. When the double-message is manipulated in the cognitive processes a unifi-

cation of the two takes place which is not unlike that described by Kālidāsa.

In order to define the svastika it is necessary to extract the messages of form and function while restricting the role of arbitrary value-judgements. Appendix I is a collection of svastika-forms. It is the field of experience, the fund of phenomena, from which a proper morphological definition of the svastika can be drawn. It is arbitrary inasmuch as I have selected the symbols, at random. It is objective by reason of the fact that all of the symbols were described by various authors as svastikas. By comparing the form and the dynamic qualities of all of these figures against each other it is possible to arrive at an understanding of the two messages of the svastika-form.

The first task is to isolate the morphological elements which comprise the pure form of the svastika.

In 86% of all forms given, the cross is present. Out of 87 examples the cross is contained as an element in 75. It is probably the most recognizable element of the svastika. The emphasis placed on this form probably accounts for the same emphasis given to the cross in the definitions of the word svastika mentioned earlier.

Hooked arms occur even more frequently than do crosses. 79 out of 87 examples contain hooks (94%). The combination of the cross and the hook precisely explains the German term,

Hakenkreuz. But there is another element which is even more common than these two in the given figures. The point, at the center of the figure, occurs in all but two examples (figures 36 and 45). Sometimes it is formed by the intersection of lines appearing only as a simple point (figures 1, 2, 5, etc.). At other times it takes the form of the circle (figures 13, 18, 19, etc.), or even of a stylized figure or flower (figures 37, 65). The point at the center of the svastika acts as a force for unification of its elements in 98% of the forms given in Appendix I.

Of these three elements, only two are essential parts of the message of pure form. The third is a by-product of a certain combination of the other two elements. Essential are the hooked arms and the central point. Compare the svastikas given in Appendix I, figures 1 and 5, 9 and 13. In both 13 and 19 the cross is interrupted by the presence of a circle at the center of the figure. For that reason it is not a cross, morphologically speaking. Figure 5 however is clearly a curvilinear variation of figure 1 in which the cross is most evident. In all four of the figures, however, hooked arms and a central point are present, as they are in all of the figures of Appendix I with the exception of 36, 42, 45, 46, 56, 62. Morphologically, those figures are not svastikas. Historically, culturally, or symbolically they may bear some relationship to the symbol, but that relationship is not part of the message of pure form.

The svastika has a dynamic quality, a subtle implication of symmetry and movement, not produced merely by the presence of the two essential elements of its morphological form. Those elements have to be arranged in such a way as to produce a specific symmetrical effect. Figures 68 and 70-73 violate the principle of arrangement and appear static rather than dynamic. Compare figure 69 to figure 72. In the latter the hooked arms are arranged in opposition to each other, and their potential dynamism is destroyed. Figure 69, on the other hand, has each of the hooks bent in the same direction, the figure is given torque, and its dynamic potential is expressed.

Anna Shepard⁴⁵ identifies three basic types of symmetrical arrangement: bilateral, radial, and rotational. She lists the svastika as an example of the third group.⁴⁶ She is correct. Of all the forms given in Appendix I, only two do not have rotational symmetry (figures 42 and 56). Respectively, the Croix Svasticale⁴⁷ and the cross-with-arrows are not svastikas.

A final point needs some short discussion. Svastikas, as defined morphologically, may have more-than, less-than, or only, four arms. Figures 15, 16, and 17 are three-armed. They are called triskelions ("three-legged").⁴⁸ Five-, or more-armed svastikas are seen in figures 23, 35, and 77. All of these forms are svastikas: figures composed of a central

point, hooked arms and conveying an impression of rotational symmetry. Nonetheless, the majority of svastika-forms are four-armed. That form is the normative svastika. It includes, however, a concept of quartering which is not derived from the intentional consistency of form exhibited by the basic symbol. Hence, quaternary, a quality often associated with the svastika, is not a part of the concept of the symbol, in and of itself.⁴⁹

IV. Summary

Svastika is a Sanskrit term applied to the卐. It was united with that symbol during the 1st millenium BC. The symbol was drawn from an established folk-idiom whose roots went back into the pre-Aryan Indus Valley civilization in India. The word, on the other hand, comes from a Vedic priestly terminology and reached full formulation during the period when Classical Sanskrit was being systematized by Pāṇini.⁵⁰ Its wide-spread acceptance by Prakrit-speaking groups suggests that among certain levels of Indian society the svastika was a symbol of prosperity and auspiciousness with an historical continuity from the ancient past up to the present.⁵¹

The symbol has dimensions which are not circumscribed by history, which derive from the intentional consistency with,

which its form has been created by man for more than 8000 years. Its morphological meaning is adherence to and rotation about a central point. Though it may be allowed any number of arms, it normally takes the shape of a four-armed figure. As a result the concept of quaternity is often associated with the svastika.

NOTES

¹The Raghuvamsa: Sri Kālidāsa's Great Epic in English Verse, trans., R. Seshadri, with Foreword by K. S. Ramaswami Sastriar (n.p.: n.p., 1939), p. 1.

²Mythology is full of accounts of the intervention of men into the affairs of the gods--though no good usually comes of it. It is a familiar motif to find Creation beginning with an account of the union of the World-parents who soon find themselves separated on account of their offspring. What parent hasn't felt that same loss of an earlier paradisaical state?

³Alain Danielou, Hindu Polytheism, Bollingen Series 73 (New York: Pantheon Books, 1964), pp. 291-297. On page 295 the author says, "The svastika is the graphic symbol of Ganesa. It is made of a cross representing the development of the multiple from the basic unity, the central point."

⁴"May it be so!," "Hail!," "It exists (is) well." All of these are meanings of the word svasti. It is an holy and auspicious word to be uttered at the beginning of any and every undertaking. It is often used as Christians use the word, Amen!

⁵Words and symbols are often difficult to distinguish without starting an argument, but I have taken my cue from Thomas Sebeok, "Six Species Signs: Some Propositions and Strictures," Semiotica 13 (1975), 233-260. Sign is used to refer to the word, and symbol to the graphic form indicated by the sign. Of course, not all signs are words nor all symbols graphic, but by using these terms in this manner I can (with Sebeok's unwitting guidance) distinguish between the two levels of meaning--and by distinguishing, I can defuse their potential for creating a greater confusion in the mind of the reader. Wilfried ver Eecke treats sign and symbol differently:

"I would circumscribe the difference between 'sign' and 'symbol' as follows...The objective given dimensions...are signs. 'When man uses these signs in concrete circumstances to express his feelings to somebody, then we get an affectively laden sign. This I call a symbol."

Wilfried ver Eecke, "The Symbol as a Philosophical Concept," International Journal of Symbology 6 (March 1975): 29n.

⁶John H. E. Fried, Collin's Encyclopedia, s.v. "Swastika."

⁷Bibliographie der Deutsches Zeitschriften-Literatur, Abteilung A, 99 vols (n.p.: Kraus Reprint Corp., 1961-1963). This is a year-by-year index of popular articles published in the German press. It is an excellent indicator of the sudden rise in popularity the swastika experienced in 1933. In all the years before that, only one article is listed (s.v. "Hakenkreuz,"). In 1933 alone more than a dozen articles were written.

⁸Thomas Finkelstaedt, Ernst Leisi, and Dieter, A Chronological English Dictionary (Heidelberg: Carl Winter. Universitätsverlag, 1970), p. 1378. Swastika is listed with brownshirt and reich.

⁹Jorg Lechler, Vom Hakenkreuz: Die Geschichte eines Symbols, 2nd ed. (Leipzig: Curt Kabitzsch Verlag, 1934), "Vorwort."

¹⁰Thomas Wilson, "The Swastika, the Earliest Known Symbol, and its Migrations; With Observations on the Migration of Certain Industries in Prehistoric Times," Report of the National Museum under the direction of the Smithsonian Institution for the year ending June 30, 1894, (Washington: Government Printing Office, 1896), p. 769.

¹¹Ibid., p. 770.

¹²Goblet d'Alviella, The Migration of Symbols, intro. George Birdwood (Westminster: n.p., 1894; reprint ed., New York, University Books, 1956), pp. xi, 32-33, and all of "Chapter II."

¹³Wilson, "The Swastika," pp. 768, 769, 774. In nearly three years of research I have never found a single disagreement to the proposition that the word svastika is to be derived from svasti. (In the same three years I have found almost no other point upon which even three people will agree.) Such a remarkable unanimity on the etymology of the swastika is, to say the least, remarkable! The addition of the suffix -ka is a more nebulous thing. Its meaning is difficult to determine exactly. In Panini's time the suffix was commonly added to words to denote affection and indicate the diminutive form. It is possible that the svastika was an amuletic talisman (literally "a small blessing.") It is also possible that the addition of the suffix accomplished the same effect that our addition

of -er to a word does. For example, compare "do" and "doer," "work" and "worker" to svasti and svastika.

¹⁴Yaska, The Nighantu and the Nirukta: The Oldest Indian Treatise on Etymology, Philology, and Semantics, critical ed., Lakshman Sarup (Delhi: Motilal Banarsidass, 1967), s.v. "3.22."

"The word svasti is [a synonym] of non-destruction, i.e., honoured existence: it exists well." (see page 55 of the English translation of the Nirukta.)

Information regarding the dating of Yaska, the author of the treatises, is given beginning on page 53 of the English section. The range of dates given there is 500-700 B.C.

¹⁵Wilson, "The Swastika," p. 772. The author quotes Max Muller's discussion of the svastika in Schliemann's book, Ilios.

V. S. Agrawala, India as Known to Panini: A Study of the Cultural Material in the "Ashtādhyāyī" (n.p.: University of Lucknow, 1953), pp. 226-227. The argument for Panini's date is given on pages 455-475, but see page 474 where the range is given as 7th-4th centuries B.C. Agrawala prefers the middle of the 5th century B.C.

¹⁶P. V. Kane, History of Dharmasastra, 5 vols., Government Orientation Series (Poona: Bhandarkar Oriental Research, 1962), p. 813. Even after the Upaniṣadic period svasti continued to be used. For references see V. R. Ramachandra Dikshitar, The Purana Index, 2 vols., (n.p.: University of Madras, 1951), s.v. "svasti."

For a listing of the uses of "svasti" in the Vedas, see Maurice Bloomfield, A Vedic Concordance (Poona: Motilal Banarsidass, 1964), s.v. "svasti."

Brief mention should be made of another word whose usage is similar to svasti. Svāhā, which was also used in Vedic ritual, was apparently the more common of the two. Yaska was familiar with this word and so was Pāṇini. In the Nirukta of Yaska (sections 8:20-21) it is said,

"Consecrations by saying 'Hail!' (they are so called because the word svāhā is uttered in them; or speech herself said, 'well ho!' or one addresses himself, or one offers oblation consecrated with (svāhā) 'hail!'

Yaska, The Nighantu and the Nirukta, page 137. Kane, Dharmasastra, cites another usage of svasti as a meritorious word. "Svastvavāna," Kane says, is the practice of "asking brahmanas to say 'it would be auspicious' after having had a dream in which significant objects were seen. (P. V. Kane,

History of Dharmasastra, p. 780). Both svāhā and svasti meant 'Hail!' and were used in the same fashion in Vedic times, and continue to be used today in much the same way. Svaha was particularly connected with Agni, the God of Fire. But the introductory and concluding oblations are also associated with the metres, and with the four directions, and the sacrificial animals. The sacrifices, set up in the easterly direction, were supposed to be undertaken along with a meditation upon the god to whom they were offered. In that case the god of the introductory and concluding formulas, i.e., svaha, svasti, yasat, and so on, had to be meditated upon as well. Yaska concludes these sections on sacrifice with a simple summary--"But the well-considered view is that they are addressed to Agni." Yaska, The Nighantu and the Nirukta, p. 138. Agrawala, India as Known to Panini, p. 367, mentions both svāhā and vasat (vaushat), but not svasti. It may be that svasti was reserved for specific sacrifices, and addressed to a different deity.

17. One of the most troubling concepts surrounding the word svastika is broached in the complex of words that surround 'Hail!' in Indo-European languages. Hail, in English is derived from the Germanic branch of I-E Middle English hool, 'healthy, unhurt'; Old English hal; Old High German heil. This word becomes heilig, 'holy' in modern German and we are familiar with the usage of 'Heil Hitler.' Originally it meant 'healthy, unhurt'; Welsh coel, 'omen'; Old Slavic celu, 'healthy, unhurt.' The problem arises in the fact that the Sanskrit svasti which has an identical meaning is not a cognate of these other Germanic words. Thus the concepts of svasti and svastika become even more isolated. In other words they are restricted to Sanskrit and to India. But a strange parallel meaning pervades both the Germanic and Sanskrit words. Both have a distinctly religious flavor, and revolve about the notions of health and wholeness. In Old Icelandic and Welsh the correlation is even closer since those languages preserve also the notion of omen.

Carl Darling Buck, A Dictionary of Selected Synonyms in the Principal Indo-European Languages; A Contribution to the History of Ideas (Chicago: University of Chicago Press, 1965), p. 300. Buck gives the same list of cognates given above, but for the Sanskrit, instead of svasti, he gives svastha (lit., "self-standing"). This idea, self-abiding, being in one's natural condition, is closely related to the meaning of svasti. A quick glance through the meanings of the -sva words in any Sanskrit dictionary reveals that the majority of them have similar meanings. Further, the same languages which reveal a dissimilarity from the Sanskrit

'Hail!' show a strong agreement in the words used for the verb 'to be,' i.e., Sanskrit, asmi; Lithuanian, esmi; Gothic, im, and so on. (See Max Muller, Comparative Mythology: An Essay, intro. A. Smythe Palmer (London: George Routledge & Sons, n.d.), p. 24. V. S. Apte, The Practical Sanskrit-English Dictionary, rev. and enlarged ed. (Delhi: Motilal Banaridass, 1975), s.v. "as" gives an interesting series of words and their meanings:

"asta...Setting or western mountain (behind which the sun is supposed to set): -2 Sunset. -stam 1 Home, abode, residence (Ved.); Rv 7. 1. 2, 10. 34. 10. -2 Death, end."
 "astakah Final beatitude, absolution (moksa).
 -kam Ved. home.

All of this is to say that svasti + -ka may well be an oversimplified etymological conclusion for which there is no historical evidence. Strictly speaking, the religious character of the svastika and its use by the Buddhists as a mark on the breasts of the dead, its connections with the notions of self-abiding and wholeness--that is to say with the holy--seem to point to ancient complex of ideas surrounding the self which are still prominent in Indian literature. The key point to understand from this discussion is that the svastika is intimately related to a whole series of words all of which have demonstrable significance in the religious tradition of India from its earliest times right up to the present. Not the least of this is the notion of the sacred as being attached to a bodily disposition--a certain fixity of being--a sense of the wholeness of self.

¹⁸V. S. Agrawala, India as Known to Pāṇini, pp. 336-337.

¹⁹Wilson, "The Swastika," pp. 802-805.

Edwin Arnold, The Light of Asia, or the Great Renunciation (New York: A. L. Bunt, n.d.), p.6.

²⁰Ibid. See also d'Alviella, The Migration of Symbols pp. 42-43.

²¹Wilson, "The Swastika," p. 773.

²²E. J. H. MacKay, Further Excavations at Mohenjo-Daro, 2 vols. (Delhi: Government of India Press, 1937), 2: plates 82.1 and 2.

²³Interview with Dr. Roy C. Amore, Religious Studies

Department, University of Windsor, Windsor, Ontario, Canada,
January 17, 1978.

²⁴I should explain my use of the term Arvan. Arvan means primarily the people speaking Indo-Iranian. But it has a secondary meaning reminiscent of Nazism--of a race of people who migrated throughout Europe and Asia during the late Bronze Age, and Iron Age. I use the term only when it is appropriate to recall the Zeitgeist of the early arguments which surrounded the study of these peoples, and when referring to the theory that the svastika belongs to a certain Germanic-Nordic-Teutonic people. My usage of the term is not to be construed as a belief in Aryans. The term is more homogenous than the people were and in that sense constitutes a connotative distortion of the facts. It is to be eschewed except in the special circumstances described above.

²⁵Pandurang Damodar Gune, An Introduction to Comparative Philology, rev. and ed. N. P. Gune (Poona: Poona Oriental Book House, 1962), appendix III, p. 30.

The evidence of Hittite use of the svastika-as-symbol is slender, and confined to the 1st millenium B.C. It is reported once from a cylinder seal, and occurs on the robes of a priest depicted on a rock-relief near Ivriz. There is no textual evidence as to the meaning of the symbol. See Heinrich Schliemann, Troja, pp. 122-128; William Wright, The Empire of the Hittites, pp. 147-153; and Maurice Viera, Hittite Art, pp. 86-87 and Plate 70.

²⁶Wilson, "The Swastika," p.772. Wilson is quoting the letter Schliemann published in Ilios, which had been received from Max Müller,

"Varahamihira in the Brihat-Samhita mentions certain buildings called Svastika and Nandyavarta, but their outline does not correspond very exactly with the form of the signs. Some sthūpas, however, are said to have been built on the plan of the Svastika... Originally svastika may have been intended for no more than two lines crossing each other, or a cross."

²⁷The Goladīpikā by Parameśvara, ed. and trans. K. V. Sarma, Adyar Library Pamphlet Series, no. 32 (Adyar, India: Adyar Library and Research Centre, 1957), pp. 69-70. The editor notes that the four cardinal points, the zenith, and the nadir are called svastika-s.

²⁸All the definitions preceding this note are from

Sir Monier Monier-Williams, A Sanskrit English Dictionary: Etymologically and Philologically Arranged with Special Reference to Cognate Indo-European Languages (Oxford: Clarendon, 1960), s.v. "svasti."

²⁹ Arthur Anthony McDonnell, A Practical Sanskrit-English Dictionary (London: Oxford University Press, n.d.), s.v. "svasti."

³⁰ Vaman Shivram Apte, The Practical Sanskrit-English Dictionary, new rev. ed. (Delhi: Motilal Banarsidass, 1975), s.v. "svastika."

³¹ Buck, Selected Synonyms, s.v. "cross."

³² I also consulted a few English Sanskrit dictionaries, s.v. "cross" to see what would be given as a Sanskrit word, and found that amongst a number of options the svastika was given. Svastika includes "iron" as a sub-category.

³³ Interview with Walter Barth and Keith Kritchlow, "90 Minutes Live," Canadian Broadcasting Corporation, December 14, 1976.

³⁴ The svastika remained a religious symbol even in the overly political setting of Nazi Germany. Hitler conceived of it as the symbol of "the mission of the struggle for the victory of Aryan man." And that mission was repeatedly characterized by him as a mission of "resurrection." One can almost sense the religious fervor of the man as he wrote,

"How many times the eyes of my lads glittered when I explained to them the necessity of their mission ...and how those lads did fight!...Like a swarm of hornets they swooped down on the disturbers of our meetings...without regard for wounds or bloody victims, filled entirely with the one great thought of creating a free path for the holy mission of our movement."

Adolf Hitler, Mein Kampf, trans. Ralph Manheim (Boston: Houghton Mifflin Co. Sentry ed., 1971), pp. 402, 495, 496, 497, 94, 113, 331, 336, 337, 367, 490, 491. See also, Richard Grunberger, The 12-Year Reich; A Social History of Nazi Germany 1933-1945 (New York: Holt, Rinehart and Winston, 1971), pp. 72-89, and Gary Lease, "Hitler's National Socialism as a Religious Movement," Journal of the American Academy of Religion 45 (September 1977): 351 (Abstract of

article).

³⁵Konrad Heiden, Der Fuehrer: Hitler's rise to Power, trans. Ralph Manheim (Boston: Houghton Mifflin Co., 1944), pp. 143-144.

"It (the swastika) has the effect of an iron octopus, a monster, aggressively reaching out in all directions--hence its menacing and frightening effect. In 1921, Hitler's new red banner with a black swastika in a white disk was unfurled in the open for the first time. The effect was so inflammatory that Hitler himself was surprised and pleased.

In the swastika historical accident gave Hitler one of his mightiest weapons. It was a lucky find."

³⁶Mircea Eliade, Mephistopheles and the Androgyne, trans. J. M. Cohen (New York: Sheed and Ward, 1965), p. 210.

³⁷I consider the need to define the subject as a critical problem in religion studies. Following Robert D. Baird, Category Formation and the History of Religion (The Hague: Mouton & Co., 1971), I do not believe that the implicit-definitional-method suffices for studies in which there is an ambiguity of meaning. Certainly, the meaning of the svastika is ambiguous. For that reason, I do not wish to allow those who read this paper to retain their own individualized understanding of the symbol. Rather, I prefer to establish a stipulative definition (one which is used to make discussion possible but which does not claim "truth-value"). The problem becomes particularly acute when the phenomenological study of the svastika is linked to the historical study. At that point, the breadth of the definition, and the subsequent inclusion of questionable forms, materially affects the conclusions arrived at. My stipulative definition is given in Appendix 1, figures 1 and 2.

³⁸Wilson, "The Swastika," p.767.

³⁹d'Alviella, The Migration of Symbols, pp. 32-33.

⁴⁰Ibid., pp. 60-62, and Plate II.

⁴¹The terms, geometrical, abstract, and representational, refer to styles of art and design, and can be easily distinguished. They do not affect the morphological analy-

sis of the svastika except as they tend to make the form less easily identifiable. For instance, figures 4, 7, and 9 in Appendix 2 are representational and the svastika is hidden by the elaboration which this style requires. Figure 3 contains both a geometric svastika in the centre and representational forms around it in the shape of birds who carry fish in their mouths. Abstract forms should be thought of as representational of geometric forms which have been carried a step farther by the artist. Figures 20, 21, and 22, etc., are examples of abstract forms.

⁴²The point of intention cannot be made too strongly. A symbol is a symbol by virtue of the content it carries, not as an historical accident, or by coincidence, but because it is consciously intended to represent something. A symbol, like a metaphor, is a tool of human expression and thought, and can only be used with purpose and intent. It is the single virtue that makes it possible to study symbols phenomenologically. In the symbol of the svastika, the form of the symbol is the vehicle of intention, and only that makes the cohesion of this study possible.

⁴³In the case of the Trojan svastikas, the question of intention is the critical one, because the material from that site exhibits svastikas of a great many forms. Many of them are very questionable as to whether they were intended as svastikas. For instance compare the various forms which exist side-by-side in figure 81 of Appendix 1. This strange band of geometric marks were inscribed on the equatorial band of a clay ball found in the ruins of Troy. Clearly, if all of these marks were intended to be svastikas the Trojans who made them had a very different understanding of the symbol than do we. So different, in fact, that it must be taken into consideration whether or not there is any relationship between the meaning of the mark as it was used in Troy, and its meaning in 20th century Germany. It may well be that two different symbols are involved, which merely appear to be similar, like the cross and the svastika.

⁴⁴V. Ja Propp, Morphology of the Folktale, 2nd ed., rev. and ed. with a Preface by Louis A. Wagner, New Introduction by Alan Dundes, Anthropology, Folklore and Linguistics series, publication 10 (Bloomington, Indiana: Indiana University Research Center for the Language Sciences, 1968), pp. 19-24. Propp describes the "morphology" of folk-tales as "a description of the tales according to its component parts and the relationship of those components to each other and to the whole." But only one of the com-

ponents is described as function, i.e., the actions of the characters.

⁴⁵Anna O. Shepard, Ceramics for the Archaeologist (Washington: Carnegie Institute of Washington, 1965).

⁴⁶Ibid., pp. 268, 272, 278.

⁴⁷Wilson, "The Swastika," p. 809.

⁴⁸d'Alviella, The Migration of Symbols, pp. 54-55.

⁴⁹Such symbols are still svastikas. I can definitely say that three-armed symbols do not mean the same thing as do four-armed figures, especially in light of the frequency with which they take the appearance of legs and call to mind the "Three Steps of Vishnu." But morphologically, they are svastikas.

⁵⁰I.e., in Pāṇini's writings, the term svastika is first discoverable.

⁵¹The Gangetic basin, where Buddhism arose, was slow to be Aryanized, and the svastika is prominent in that religious movement. But the process could also be looked at in reverse in the case of the svastika. Aryan culture was being assimilated into Indian culture.

CHAPTER 2

The Roots of the Svastika

I. Introduction

Not only is the svastika as old as civilization in the proper sense of the word,¹ it is as widespread as well. Its roots extend far beyond the limits of the Indian sub-continent, even to some of Europe's most ancient ruins. It has been found in all of the seven cities of fabled Troy, in the ancient Anatolian graves of the unknown kings of Alaça Hüyük. At least 6000 years ago it penetrated the interior of Iran. Eighty centuries ago, the svastika was a part of the symbolic idiom of the early farmers of Northern Mesopotamia.

By the time the Iron Age had reached its height, there was virtually no part of the European and Asian world which did not know the symbol.² Along with the spread of Greek civilization the svastika attained to its widest distribution. Ample evidence exists to document its use by Christians in the 1st-2nd millenium A.D.³ During the Viking Era it was a familiar symbol in Northern Europe. Mayans, Aztecs and Incas used the svastika, though infrequently. In the middle of the 2nd millenium A.D., the symbol appeared

as a major motif among the Hopewell Indians, and some tribes of the southwestern United States.⁴

Since the outbreak of the svastika in our own time, no major study of the symbol has been made. In spite of the vast impact which it has had on the lives of millions, in spite of the fact that it may be the most important symbolic event of the century--no important study of the svastika has reached print in the last thirty years.⁵ In a hundred years of study no single clear view of the symbol has emerged. The controversy surrounding the svastika, its origin and meaning, raged into the Twentieth-century, and burst into open flame in the Holocaust. Behind it all, was the single view: that the svastika was the sign of Aryan man. Even today, that claim has not been seriously challenged.⁶ Even though the history of the symbol refutes that belief, it remains still the most widely-held view on the origins of the svastika. As recently as 1974 exactly that claim was put forth in a paper given before the All-India Oriental Congress.⁷ The purpose of this chapter is to refute that view and offer in its place a more correct historical understanding of the roots of the svastika.

Fortunately, it is not necessary for that purpose, to give an exhaustive account of all of the occurrences of the svastika throughout its long and varied history. Only the period between 6000 and 3000 B.C. need be considered.

During that time, in northern Mesopotamia, Anatolia, and India, the svastika was a familiar symbol in use long before the first contact was made with the Indo-Europeans or the Aryans.⁸

II. Samarra

In the midst of the 6th millenium B.C. an obscure band of people settled on the alluvial fringes of the Tigris River in northern Mesopotamia.⁹ Three things are remarkable about these people: they used irrigation techniques to make their arid land hospitable; they used sun-dried mud bricks for the first time in Mesopotamian architecture;¹⁰ and the svastika was an important symbol in their way of life.¹¹

Knowledge of the existence of these peoples was first found in 1910. Ernst Herzfeld, excavating an extensive unstratified prehistoric graveyard, turned up some of the most beautiful painted pottery ever found anywhere.¹² This Samarran ware (named for the site at which it was found) frequently used the svastika as a central element of design. The complex symbolic constructions were then painted on the interiors of shallow bowls and apparently buried with the dead. No other archaeological site has produced evidence for an earlier svastika.¹³ Only there, at the end of the neolithic age, did the svastika emerge as a part of a mean-

ingful symbolic idiom.

Herzfeld first dated Samarran ware to 3000 B.C., but that date has been repeatedly revised backward.¹⁴ The most recently proposed dates (5600-5200 B.C.) place it in the earliest (Hassunan) horizon of Mesopotamian civilization.¹⁵ Along with its date, the nature of the Samarran material has also been revised as a result of other discoveries at Baghouz, Tell-es-Sawwan, and Choga Mami. In a recent article, Joan Oates reported that,¹⁶

For a long time 'Samarra' defined nothing more than this elaborate ceramic style which came to be considered an imported or 'luxury' ware and later simply 'one aspect of the later phase of the Hassunan assemblage.' Recent excavations at Tell-es-Sawwan and Choga Mami, however, have confirmed what was suspected from the evidence at Baghouz on the Euphrates, that Samarra must be considered a separate assemblage (sic) and that the people this assemblage represents flourished some time in the sixth millennium north of Baghdad along the fringes of the alluvium.

The overall picture of Samarran life is still indistinct, though certain important details are known. Samarrans were the first to use sun-dried mud bricks in building construction. They had a rudimentary irrigation and domesticated animals (cattle, sheep and goats). Craft specialization is evident in their remains as is a vast amount of surplus wealth. Terra-cotta and alabaster figurines were found at all sites. Though these varied in many respects from site to site, certain features were shared, including the use of 'coffee-bean' eyes, elaborate head-dresses, and

appliqué necklaces.¹⁷

Their cities were often walled and well-planned. The rectangular houses were divided into a number of rooms. External buttressing of corners and wall junctions was another Samarran innovation which would become wide-spread in Mesopotamia at a later date, especially in religious architecture.¹⁸

Beneath the earliest level of Tell-es-Sawwan (but clearly associated with buildings of that level) a large number of graves were found containing literally hundreds of stone objects, female statuettes, and elegantly-shaped alabaster bowls. The earliest copper objects ever found in Mesopotamia were also found at Tell-es-Sawwan.¹⁹

According to James Mellaart, three stages mark the development of Samarran culture:²⁰

Early Samarra (without painted pottery), the classic Middle Samarra, and at Choga Mami, a late Samarra in which naturalistic design appears.

The key to these periods, as defined by Mellaart, is their pottery, but another major distinction between Early and Middle Samarran is noticed in burial practices. Early Samarran dead were buried beneath the buildings of the period, but Herzfeld's Middle Samarran graveyard was extra-mural. At the same time the alabaster bowls were replaced by the elegant painted pottery on which the svastika appeared. A most significant fact is that the pottery of

Middle Samarra was apparently modelled on "basketry and woven textiles" while that of Tell-es-Sawwan was derived from stone and alabaster prototypes.²¹ This fact is significant for the simple reason that the svastika first appears already a part of a fully-developed symbolic idiom for which there is no precedent. So complex a constellation of symbols could not have sprung into being overnight. A period of development must have preceded it. But no remains of it have been found. In this mystery, the origins of the svastika lie hidden.

The only clue to its solution is the similarity of many Middle Samarran patterns to those which could have been developed in basketry. The linear, woven patterns of basketry, inherent in the techniques of production, lend themselves admirably to the geometric ornamentation of early pottery. The svastika may have been just such a pattern. Figure 18 of Appendix 2 illustrates the connection between design in basketry in that of pottery. Figures "a", "b" and "c" are ceramic bowls from the southwestern United States (Mimbres culture--see note 23 of this chapter). Figure 18, "d" and "e" are examples of plaited and coiled work used in basketry (also from the American southwest). The basket pictured in figure 18 "f" is comparable to the ceramic bowl pictured in 18 "c". 18 "a" is reminiscent of 18 "d". In the pattern extending from the centre of bowl "f" the svasti-

ka is clearly outlined. Five frogs, a figure common on both Samarran and Mimbres bowls, point their heads toward the centre of the bowl. Unfortunately, the great age of Samarran culture and the perishability of woven materials may forever prevent us from obtaining material evidence for this hypothesis. But the evidence, as it exists today, strongly suggests that the svastika was developed as a basketry pattern during the neolithic age.

On the origins and ultimate end of Samarran culture, there is, at the moment, only conjecture. Oates suggests a Hassunan influence and others have suggested an Iranian origin.²² Mellaart, on the other hand, favors the theory of a local origin.²³ By 4500 B.C. the Samarran sites were deserted and its occupants had disappeared almost as abruptly as they had come.²⁴ With them went the svastika, not to appear again in Mesopotamia for thousands of years.

The Samarran svastikas are without doubt the strongest evidence that the svastika originated outside of the Aryan sphere of influence. There is absolutely no evidence that I-E-speaking peoples had infiltrated this area at so early a date. In fact, the earliest movement of I-E peoples out of their southern Siberian Urheimat (homeland) does not take place until nearly 2000 years later.²⁵ The earliest evidence of I-E languages spoken in the area comes from the 2nd millenium--nearly 4000 years after the Samarrans had

disappeared.²⁶

III. Interlude in Iran

Directly east of Samarra, beyond the foothills of the Zagros Mountains, near Tehran, lie the ancient mounds of Tepe Sialk. At the end of the neolithic age this settlement flourished as a trade centre linking those areas on either side of it.²⁷ Like the Samarrans, the inhabitants of Tepe Sialk combined hunting and fishing with agriculture to provide a stable food supply, herded goats, and buried their kin beneath the floors of their houses. They used the svastika as well.²⁸ The pisé walls of their houses rested on mud-brick foundations.

The real nature of the relationship that existed between Sialk and Samarra is difficult to determine. Dyson²⁹ suggests an Halafian influence. That view doesn't account for the svastika which appears nowhere in other Halafian horizons. On the other hand, Samarran culture, which is similar to that of Halaf, did possess the svastika and was contemporary with Sialk I. Given the trade pattern of the area at the time, it is probably wise to conclude that both Samarran and Halafian cultures were in contact with Sialk.

In the 1930's Sir Aurel Stein, conducting a whirlwind tour of "Ancient Persis," reported the discovery of a

painted pottery (sherds only), at a number of shallow, poorly stratified sites (Tal-i-Regi, Tal-i-Skau, Tal-i-Siah).³⁰ The pottery had an elaborate repertoire of design, including maltese crosses, meanders, chevrons, and svastikas. Birds and the familiar long-horned deer appeared with the svastika in the Tal-i-Skau material.³¹

Because of the poor stratification of the site, and because of the character of Stein's sondages, dating of the sites is difficult. The author described the finds as being directly over neolithic material.³² If they are transitional, (neolithic to chalcolithic) their relative position in Iranian archaeology would be c. 4000 B.C.--contemporaneous with Sialk III, and Elamite beginnings in Susa. The Samarrans were gone from northern Mesopotamia by that time.

By 3500 B.C. Elamite civilization had grown strong, and its capital at Susa was engaged widely in trade. Evidence of that trade has come recently from excavations undertaken in Tepe Yahya by the Lamberg-Karlovsky's.³³ They describe the IVth level as a proto-Elamite city and trading outpost whose specialty was the manufacture of steatite products. Lamberg-Karlovsky do not report finding svastikas such as there were in the capital of Elam, but do state that they found a number of pot-marks and³⁴

examples of every major motif represented on the numerous soapstone bowls unearthed at Bronze Age sites in Mesopotamia and the Indus Valley.

Other sites in Iran, Afghanistan and Baluchistan yield evidence of the continued use of the svastika well into the 2nd millenium B.C.³⁵ Bakun A, Damb Sadaat, and Bampur-Makran, respectively, used the symbol in what Dyson described as a "major spread of cultural items through Iran."³⁶ The svastika was one of those "items."

While the details of diffusion are unclear, the overall pattern is well-established: a painted pottery culture of Mesopotamian origin spread south from Samarra and Tepe Sialk through Iran, Afghanistan and Baluchistan to the very borderland settlements out of which the civilization of the Indus Valley arose.³⁷ South and east, the wave of culture carried the svastika to India and ultimately, China. And along with it, was carried the bull figurines, female statuettes, potter's marks, stamp-seals, house-types, village layouts and burial customs.³⁸

The proto-Indian civilization that arose from the flood-plains of the Indus River and her tributaries owes much to the earlier Indian culture. But there are also factors of Harappan life that cannot be accounted for-- which are unique! Fired-brick architecture, large and highly organized urban centres, and the proto-script are the major characteristics of the mature Indus culture (2500-1750 B.C.) which are not found in the borderlands of Iran.³⁹

There are also some significant differences in

pottery styles. For instance, the emphasis on painted-ware declines, while plain and incised ware becomes more common.⁴⁰ Another change takes place in the designs of the pottery: the svastika disappears from the repertoire of painted designs completely! From the beginning of mature Harappan civilization to its end (c. 1750 B.C.), the svastika appears only as a motif on stamp seals.⁴¹

Thus, the diffusionary wave from Mesopotamia, which carried many cultural items through Iran to the borderlands of India may be viewed as the vehicle of the svastika's migration. But it does not account for the medium of its use. The incised proto-script on stamp-seals with which the svastika is associated bears a closer resemblance to the pottery and the spindle-whorls of Troy than to the painted pottery of Iran and Samarra.

IV. The Western Branch

At about the same time that Tepe Yahya was a trading colony of the Elamite empire in Iran, the proto-Trojans were establishing their first foothold on the Scamander Plain in Northwestern Anatolia.⁴² 500 years later (c. 3000 B.C.), they moved to the high-ground of a near-by ridge and founded Troy.⁴³ There the colony flourished and grew. Setbacks led to rebuilding and the city rose, like a phoenix, from its own ashes until seven cities topped the site. In

each city the svastika was used by the inhabitants.⁴⁴ Literally hundreds of bowls, vases, and spindle whorls were found which were decorated with rude incisions: svastikas, crosses, trees, human figures, animals, chevrons, circles, and other, undeciphered, marks.⁴⁵ Often, the incisions would then be filled with a white paste to bring out the pattern in sharper relief.

Troy eventually yielded evidence of more than 3000 years of the continuous use of the svastika.⁴⁶ Because of that fact, d'Alviella, writing in ignorance of the yet-undiscovered Mesopotamian and Persian svastika, believed the Trojan examples to be the oldest found anywhere. From Troy, he maintained, the svastika spread like an octopus into Mycenae, Greece, Italy, and eastward to the Caucasus and India. From India, it went to China, Tibet, and Japan. A second wave of migration (c. 500B.C.) carried it out of Greece and Italy to northern Europe: Gaul, the British Isles, and Scandinavia.⁴⁷

The Count's view of the diffusion of the svastika was partially based on an incorrect estimate of the relative ages of painted and incised decoration. He believed the incised style to be "everywhere the most ancient."⁴⁸ His estimation is incorrect. For instance, the painted pottery of the Yang-shao culture of China is far older than the incise ware of Italy. The Mesopotamian sequence of painted

U

pottery is older than the Trojan ware which is incised, and so on.

Nevertheless, his belief led him to a conclusion which still stands the test of time. Noting that incised ware was found, complete with the svastika, in both the Troad and Italy, he suggested that the symbol may have been introduced into the area from a third source--the Danube Basin.⁴⁹

who will be astonished that these emigrants had taken with them, to the opposite shore of the Hellespont, the symbols as well as the rites and traditions which formed the basis of their creed in the basin of the Danube.

In spite of d'Alviella's inversion of the relative age of incised and painted pottery, his view on the origins of the svastika finds support in modern scholarship. DeShayes,⁵⁰ Mellaart,⁵¹ Gimbutas,⁵² and Winn,⁵³ all look to southern Europe and Danubian civilization for the antecedents of Trojan culture. Pottery shapes, design repertoires, and the use of white paint to fill the incisions, are characteristics which illustrate the connections between these two areas. Other objects, common to both, are:⁵⁴

stone axes, adzes, chisels, mace heads of shell, bone implements, antler sockets used to mount a handle on stone axes in accordance with the common practice of Danubian neolithic; sling pellets of dried clay (no arrowheads were picked up in these levels) and incised spindle whorls complete the list.

Direct evidence of the priority of the svastika in

Danubian--"Old European"⁵⁵--civilization comes from Tordos a little way to the east of Vinca.⁵⁶ Schmidt⁵⁷ (1903) and Winn (1973)⁵⁸ published studies relating the svastika to the proto-script used in that area during the 5th and 4th millennia B.C. Winn, working with a better chronology than that which was available to Schmidt, claims that the script-like incisions represent a system of writing independent of external influences.⁵⁹ The svastika, Winn claims, had an independent, symbolic status, but was not actually a part of "Old European" script.⁶⁰

From Vinca-Tordos, the symbols of Danubian civilization spread to Troy, and then to other sites throughout Northern Anatolia. At Kazaoglan⁶¹ and Alaça Hüyük⁶² svastikas have been found dating from the 3rd millennium B.C. But the general pattern of the distribution of the svastika east from Troy is very mixed and uncertain. No clear lines of diffusion can be drawn from Tordos to Alaça Hüyük. The svastika occurs only sporadically in northern Anatolia in the 3rd millennium, and not at all in the south. It is not possible to connect the western svastika with the proto-Indian civilization of the Indus Valley via diffusion through Anatolia and the Near East. The similarities between the use of the svastika in "Old European Civilization," Troy, and the Indus remain for the moment unexplained.

The rise of the svastika in Tordos, apparently inde-

pendently of its eastern counterpart, raises anew the question of I-E influence. The most recent evidence, however, suggests that the Vinča culture arose prior to the spread of Indo-Europeans into the area.⁶³ Stretching back into the 7th millenium B.C., Danubian civilization was well on its way to developing its own, unique character when it was overrun by the I-E Kurgan (grave-mound) peoples (c. 3500 B.C.).⁶⁴ Inasmuch as the svastika was already a part of the Vinča-Tordos culture prior to that time, it could not have been brought there by the I-E invasion. ✓

The information for Troy is similar and leads us to the same conclusion. If the Indo-Europeans ever came to Troy, and it is likely that they did, their arrival probably coincides with the end of the 5th city and the beginning of the 6th (c. 2000 B.C.). Carl Blegen offers convincing proof of this. He notes an intrusive element causing a break in the cultural continuity of the site, for the first time following Troy V.⁶⁵ ✓

a survey of the ruins of the Sixth Settlement and of the miscellaneous objects recovered from them reveals at once striking differences and innovations as compared with the preceding period on the hill at Hisarlik. The changes seem to me to be so unheralded, so widespread, and so far-reaching that they can only be explained as indicating a break with the past, and the arrival and establishment on the site of a new people with a heritage of their own.

He goes on to describe major differences in planning

and architecture; the use of bronze; and the shape of many miscellaneous items (sword pommels, loom weights, spindle whorls, whetstones, etc.). The pottery shapes of Troy underwent such a vast change that Blegen and his associates were obliged to devise a separate scheme of classification from that which had been used throughout Levels I-V. 90 of the 98 pottery shapes found in the VIth settlement were new to the site.

Evidence that this "new people" were Indo-Europeans is deduced from the fact that Grey Minyan Ware and horse bones (both traditionally associated with I-E's) appear on the site for the first time.⁶⁶

All in all, there is little evidence that I-E speaking peoples exercised any influence in Anatolia before the latter half of the 3rd millenium B.C. when the svastika was already established at Troy.

V. The Śvastika in India

The archaeological evidence for the presence of the svastika in the Indian sub-continent begins with the Indus Valley civilization whose antecedents we have already explored.⁶⁷ Outside of that environment, there is evidence to suggest that the svastika was an element in early indigenous civilization in India.

One Iron-age site in Broach District at Nagal is interesting. The excavation there revealed a single occupation represented by Black-and-Red ware. In the middle of its three phases (pre-2nd century B.C.), and in association with a thick grey ware, inscribed Red-and-Black ware was found. The inscriptions are interesting because of their similarity to the symbols which appear on punch-marked coins from about the same period.⁶⁸ Interesting also, is the connection between Black-and-Red ware and non-Vedic cults.

Hyla Stuntz Converse's article on the Agnicayana⁶⁹ relates the ritual to non-Vedic indigenous sources which she claims are represented by Black-and-Red ware. From 1100-500 B.C., during the Vedic period these peoples lived side-by-side with a Grey Ware people and shared the patterns of pottery decoration. This description tallies exactly with the excavation at Nagal.⁷⁰ Furthermore, according to Converse's article, a Northern Black Polished Ware penetrated the area during the 7th century--a pottery style which was also found in the excavation under discussion.

From the information given in the Converse article, it is possible to tentatively identify the Nagal habitation as occurring near the end of the Vedic period. As such it dovetails nicely into the evidence presented in the first chapter of this paper. There, it was hypothesized that the svastika (as a word) was a re-emergence of a non-Vedic sym-

bol connected with a traditional folk-idiom of symbols. This re-emergence was dated to the period between the 8th and the 6th century B.C. on the evidence from Yaska and Pāṇini. Its popularity among Buddhists and Jaina (Prakrit-speaking peoples) was noted. In this respect, Converse writes,⁷¹

All of the original holy places of Jainism and Buddhism are located in the area of the Black-and-Red ware culture, none in the Grey ware area.

It would appear that the early linguistic evidence, and the archaeological evidence suggests that the svastika was first and foremost (during this period) a sign associated with the Black-and-Red ware peoples, and that it was from this strata that Buddhism and Jainism emerged.

Converse also connects the Black-and-Red ware culture with the Harappans. She notes that in the whole of the RgVeda there is no word for brick; that in the Satapatha Brahmana, the Agnicayana is the only ritual described which uses bricks; that the bricks described correspond in size to those used in Harappan civilization; and that brick-making was part of the Black-and-Red ware culture.⁷² S. R. Rao adds fuel to this fire with his comment that Black-and-Red ware is also to be found in the vicinity of the Gujarat Harappan sites.⁷³

This chain of details very strongly suggests that the svastika emerged in the post-Vedic period as a symbol whose roots were Harappan.*

*The use of the symbol after the Harappan period--and

The svastika has also been found elsewhere in connection with Grey ware during the earlier Vedic period. Between 1100-800 B.C. svastikas with rounded arms were used at Hastinapur and at Shahi Tump to the north.⁷⁴ The Shahi Tump material fits into the latter part of the interlude in Iran, and may well be evidence of the use of the svastika by I-E peoples. It represents the end of a northern Grey ware invasion which began in northern Iran at the terminal end of the painted ware period.⁷⁵

Finally, the use of the svastika in the Harappan civilization provides further evidence of the non-Indo-European origins of the symbol. This unique and advanced culture, which arose in northern India (modern Pakistan) during the 3rd millennium B.C., grew out of a fusion of Iranian, and indigenous traits.⁷⁶ The former, as we have seen, represented a diffusion of culture from northern and southern Mesopotamia. The latter, according to Converse, was Dravidian. In the union between the two, the svastika shifted from painted pottery to the seals of the Indus Valley, for reasons as yet unknown. A possible explanation may be the standardization of symbols necessary for successful international trade. Svastikas, similar to that illustrated in figure 11 of Appendix 1, have been found at three widely-separated sites (two of which are known to have had trading prior to its indigenous emergence among Jainas and Buddhists --was preserved by the Black-and-Red ware peoples.

contacts): Tordos,⁷⁷ Tell Brak,⁷⁸ and Lothal⁷⁹ (see Appendix 6). If, as has been suggested, the Harappan seals were used in trade, the shift of the svastika from painted pottery to seals could have come about through economic necessity.

VI. Summary

The archaeological evidence from 5500 B.C. to 2500 B.C. shows that underneath the Indo-European associations with the svastika, lies an older and consistently well-developed use of the symbol by people who were not Indo-European. Mesopotamian, Danubian, Trojan, and Indian svastikas all occur prior to contact with Indo-Europeans.

The symbol occurs in two unrelated branches and two different styles. In the east, the earlier branch, it is associated with the painted ware cultures appearing for the first time in northern Mesopotamia. The later incised-ware svastika, common to Tordos and Troy, forms the western branch. The two appear to be unrelated, but the evidence in that respect is incomplete. Not enough is known about Danubian civilization in the 6th-5th millennium B.C. to rule out the possibility of an early diffusion. The development of early civilization in these two areas (and their relative chronologies) is the foremost problem of modern archaeology.

The question of an Ur-svastika cannot be settled until that larger question is resolved, and even then the evidence may not be relevant to the ultimate roots of the svastika. Their origin may lie in pre-pottery materials, i.e., basketry and textiles. Just as the Samarran designs must have had a prior period of development, the proto-script of Danubian civilization must also. But, the perishability of woven materials of neolithic age may forever prevent us from finding those roots.

NOTES

¹Walter A. Fairservis, Jr., The Roots of Ancient India: The Archaeology of Early Indian Civilization, 2nd ed., enl., (Chicago: University of Chicago Press, 1975), p. 217.

²Wilson, "The Swastika," pp. 839-879.

³Ibid., p. 776.

⁴On the Vikings, see H. R. Ellis Davidson, Gods and Myths of Northern Europe (Harmondsworth, Middlesex, England: Penguin Books, 1964); and Pagan Scandinavia (London: Thames and Hudson, 1968). On Hopewell, Wilson, "The Swastika," pp. 879-893; James B. Griffin, ed. Archaeology of the Eastern United States (Chicago: University of Chicago Press, 1964); Olaf Prufer, "The Hopewell Cult," New World Archaeology; Theoretical and Cultural Transformations, Readings from Scientific American series (San Francisco: W. H. Freeman & Co., 1974), pp. 222-230. On Mimbres Ware see J. Walter Fewkes, Archaeology of the Lower Mimbres Valley, New Mexico, Smithsonian Miscellaneous Collections series, vol. 63, no. 10, publication 2316 (Washington: Smithsonian Institution, 1914); Designs on Prehistoric Pottery from the Mimbres Valley, New Mexico, Smithsonian Miscellaneous Collections Series, vol. 74, no. 6, publication 2713 (Washington: Smithsonian Institution, 1923); Additional Designs on Prehistoric Mimbres Pottery, Smithsonian Miscellaneous Collections, vol. 76, no. 8, publication 2748 (Washington: Smithsonian Institution, 1924).

⁵The most recent treatments of the svastika were all done in the 1930's.

⁶Prince John Loewenstein and W. Norman Brown both wrote articles arguing against the Indo-European origins of the svastika. Both have been fairly widely ignored.

⁷Rasik Vihari Joshi, "Svastika--A Solar Symbol of the Aryans," (abstract) All-India Oriental Congress 37 (1974): PR-34.

⁸Other sites will also be mentioned in connection with the three in the course of the argument. But, the sites of Troy, Tordos, Samarra, Sialk, Harappa, and Lothal carry the bulk of the material.

⁹Joan Oates, "Early Farming Communities in Mesopotamia; The Samarran Phase," Journal of the Proceedings of the Prehistorical Society 39 (1973): 165-172.

¹⁰Ibid.

¹¹See Appendix 2, figures 3-17, 30.

¹²Oates, "Early Farming Communities..."

¹³Joseph Campbell, The Masks of God; Primitive Mythology, rev. ed., (Harmondsworth, England: Penguin Books, 1976), p. 257. Campbell writes, "in the Ukraine, in a (paleolithic) site called Mezin, there appears the earliest swastika of which we have record--"

The Mezin design, part of which resembles the svastika, was not intentionally meant to be a svastika-symbol. It is more properly called a meander. Since it does not meet the requirements set forth in the first chapter of this paper, it is not here considered a svastika.

See also, Levko Chikalenko, "The Origins of the Paleolithic Meander," The Annals of the Ukrainian Academy 3 (1953): 518-534. The article is a morphological analysis of the design to which Campbell refers. Chikalenko clearly shows that the basis of the meander is the chevron, and that the svastika is sometimes produced as an incidental part of the over-all pattern.

¹⁴Prince John Loewenstein, "Swastika and Yin-Yang," Nine Dragon Screen; Being Reprints of Nine Addresses and Papers Presented to the China Society, 1909-1945 (London: The China Society, 1965), pp. 5-28.

¹⁵Oates, "Early Farming Communities..." p.165.

¹⁶Ibid.

¹⁷Ibid., pp. 166-167.

¹⁸Ibid., pp. 168-169.

¹⁹Ibid.

²⁰Mellaart, *Neolithic Near East*, p. 150.

²¹Ibid., pp. 150-154.

²²Oates, "Early Farming Communities..." pp. 166, 171-172.

²³Mellaart, *Neolithic Near East*, p. 155. An interesting, if vexing, problem arises in regard to the local-origin theory of Samarran ware. The three phases of Samarran culture are unitary in terms of their cultural affinities, but "classical" Samarran ware is restricted to 'Middle Samarran' and is largely defined by decorative techniques. Early Samarran ware, known only from Tell-es-Sawwan, is modelled on the alabaster vessels found in the lowest levels of that site whereas the ware found by Herzfeld is, according to Mellaart, derived from basketry proto-types, which implies some sort of discontinuity between Sawwan and Samarra. Now compare figures 3-17, 30 with figures 18-29 in Appendix 2 of this paper. The first group is Samarran (6th millenium B.C.) while the second is Mimbres ware (2nd millenium A.D.). Geographically they are as far apart as New Mexico and Iraq. 70 centuries and thousands of miles separate these two wares from each other, yet stylistically they have much in common. Both were found in isolated and unstratified burial deposits. Both shared their area with another similar culture which did not use the svastika. Both are considered "Neolithic!" Both are ascribed a local origin. The design repertoire of each of these pottery styles displays a progression from realistic, to abstract, to geometrical (a progression shared also with the signs of most languages). The similarities between the two are staggering. I do not hesitate to suggest that if they were adjacent finds they would have been analysed as related at least in terms of their symbolic idioms. Also, the burial-styles of the Mimbres people--under the floors of the house and in the unstratified deposit --follows exactly that of the Samarrans. All in all, there is enough evidence to say that the two cultures bear an uncanny resemblance to each other. Of course, nothing short of a science-fiction time-machine could bring them together in a meaningful chronological relationship. How then do we account for these similarities?

There is another complication which underlines this

problem. Dupree's work in the Al Kupruk caves in Afghanistan has turned up another pottery style of decorative art bearing a close relationship to the Samarran material. But the deposit is dated to the 3rd-5th centuries A.D. (Louis Dupree, "Prehistoric Research in Afghanistan, 1959-1966," Transactions of the American Philosophical Society, New Series, vol. 62, part 4 (1972), pp. 35-42.) The repertoire of designs includes not only svastikas, but a peculiar deer-like figure whose body is composed of two triangles, point to point (like an hour-glass lying on its side--or a double-ax), and with long undulating horns curving over the full length of the body. An identical animal is reported by Mallowan from Tell Arpachiyah (M. E. L. Mallowan and Rose J. Cruickshank, "Excavations at Tell Arpachiyah," Iraq 2 (1935), pp. 1-178).

In view of the foregoing, I couldn't agree more with the observation of Dyson's (see Dyson, "Relative Chronology of Iran," in Ehrlich, Chronologies in Old World Archaeology, p. 221):

"This sequence pinpoints one of the major problems of Iranian archaeological discussions: the tendency to rely almost exclusively upon design parallels (sometimes of the most tenuous nature) to the exclusion of shape, non-ceramic objects, and basic technology...The difficulty of using this material is compounded by the demonstrable longevity of some of the design motifs and their independence of movement in relation to pottery shapes and other types of objects."

On the other hand it has to be pointed out that to say that these three examples are not related via pottery shapes is not the same as saying that they are not related at all. There can be no doubt that something connects these widely-separated cultures with each other. That "something" is the symbolic idiom itself. The first chapter of this paper illustrated the universal scope of meaning that symbols impart to those who participate in its existence, and when this universality of symbols is taken into consideration along with the conservative nature of religious systems as a whole, it is not surprising that similar symbols recur in otherwise unrelated circumstances. It is no more impossible that these symbols should be used in such a manner than that Eliade should find a similarity in the symbolism of eggs between various distant societies. It is the role of this paper to open the door to the possibility that such things do happen. Finally it should be noted that the absence of the svastika in Hassunan and Halafian cultures (even though they had a geographical and chronological intimacy with the Samarrans), emphasizes another aspect of symbols. They do not necessarily flow from culture to cul-

ture like water seeking a basic level. Rather they are absorbed by those cultures which have an affinity for the symbol. Hassunan culture apparently did not, while the Mimbres culture did. It is the very existence of historical curiosities such as these that make studies such as this one necessary.

²⁴Mellaart, Neolithic Near East, p. 155.

²⁵See notes 63 and 64 of this chapter, and maps 3 and 4 of Appendix 3.

²⁶Mellaart, Neolithic Near East, p. 281.

²⁷Dyson, "Relative Chronology of Iran," pp. 218, 236, and 248.

²⁸Mellaart, Neolithic Near East, pp. 189-194.
Fairservis, Roots of Ancient India, pp. 107-108.

²⁹Dyson, "Relative Chronology of Iran," p. 236.

³⁰Sir Aurel Stein, "An Archaeological Tour of Ancient Persis," Iraq 3 (1936): 1-226, and Plates 12-30.

³¹Ibid., Plate 24.

³²Ibid., p. 187. And on page 189, Stein describes more fully the chalcolithic design repertoire:

"Very common elements are chequers, solid or hachured, often combined with hour-glass shapes; rosettes; volutes; maltese crosses; swastikas; crosslets; cross-hachured or reserved pearls or roundels; meanders; broad leaves, also reserved; multilinear Greek cross; and the 'frog' shape; eyes; ...animal figures occur but rarely."

³³C. C. Lamberg-Karlovsky and Martha Lamberg-Karlovsky, "An Early City in Iran," Scientific American (June 1971) pp. 102-111.

³⁴Ibid., p. 108.

³⁵Fairservis, Roots of Ancient India, pp. 144 (fig 35).

³⁶Dyson, "Relative Chronology of Iran," pp. 218, 249-250.

³⁷George F. Dales, "A Suggested Chronology for Afghanistan, Baluchistan, and the Indus Valley," in Ehrich, Chronologies, pp. 257-284.

Fairservis, Roots of Ancient India, pp. 218-219.

³⁸Ibid.

³⁹S. R. Rao, Lothal and the Indus Civilization, Foreword by Sir Mortimer Wheeler (New York: Asia Publishing House, 1973), pp. 235, 237.

⁴⁰A. D. Pusalker, "The Indus Valley Civilization," The Vedic Age, The History and Culture of the Indian People Series, gen. ed., R. C. Majumdar (Bombay: Bharatiya Vidya Bhavan, 1965), p. 185.

E. J. H. Mackay, Further Excavations at Mohenjodaro, 2 vols. (Delhi: Government of India Press, 1938), 1: 184.

⁴¹Ibid., inter alia., and Rao, Lothal, inter alia.

⁴²Jerome W. Sperling, "Kum Tepe in the Troad," Hesperia 45 (1976): 303-364.

⁴³Ibid., p. 356.

⁴⁴Schliemann believed that the svastika was not used in Troy I and II. But Blegen found them in all levels.

⁴⁵See Appendix 5.

⁴⁶Carl W. Blegen, Troy and the Trojans, Ancient People and Places series, gen. ed., Glyn Daniels (London: Thames & Hudson, 1963). See Blegen's chronological chart at the end of his book.

⁴⁷D'Alviella, Migration of Symbols, Plate III (facing page 80).

⁴⁸Ibid, p. 76.

⁴⁹Ibid., p. 79.

⁵⁰Jean DeShayes, "Dikili Tash and the Origins of Troadic Culture," Archaeology 25 (1972), pp. 198-205.

⁵¹Mellaart, "Anatolia and the Balkans," Antiquity 34 (1960): 270-278. See especially pages 273-275.

⁵²Bibbutas' argument is indirect. Since "Old European" is non-Indo-European (pre 3500 B.C.), its influence on Troy is also non-Indo-European. See note 55.

⁵³Milton McChesney Winn, The Signs of the Vinca Culture--An Internal Analysis: Their Role, Chronology, and Independence from Mesopotamia (Unpublished Doctoral dissertation, UCLA, 1973; Xerox ed., Ann Arbor: University Microfilms, 1978), pp. 6, 102.

⁵⁴DeShayes, "Dikili Tash," p. 204.

⁵⁵Marija Gimbutas, The Gods and Goddesses of Old Europe, 7000-3500 BC; Myths, Legends, and Cult Images (Berkeley: University of California Press, 1974).

⁵⁶Colin Renfrew, Before Civilization: The Radio Carbon Revolution and Prehistoric Europe (Harmondsworth, England: Penguin Books, 1976), pp. 102-103.

⁵⁷Ibid.

⁵⁸Winn, Signs.

⁵⁹Ibid., pp. 252, 268, 289-295.

⁶⁰Ibid., p. 281.

⁶¹U. Bahadir Alkim, Anatolia, 2 vols., trans. James Hogarth, Archaeologia Mundi Series (Cleveland, Ohio: World Publishing Co., 1968-1969), 1: plate 58.

⁶²Machteld J. Mellink, "The Royal Tombs at Alaca Hüyük and the Aegean World," The Aegean and the Near East: Studies Presented to Hetty Goldman on the Occasion of her 75th Birthday, ed. Saul S. Weinberg (New York: J. J. Augustin, 1956),

pp. 39-58.

Ekrem Akurgal, The Art of the Hittites, trans. Constance McNab (New York: Harry N. Abrams, 1962).
Alkim, Anatolia.

⁶³Ibid. See also Marija Gimbutas, "Proto-Indo European Culture: The Kurgan Culture During the Fifth, Fourth, and Third Millenium BC," Indo-European and Indo-Europeans: Papers Presented at the Third Indo European Conference at the University of Pennsylvania, ed. Henry M. Hoenigswald and Alfred Senn (Philadelphia: University of Pennsylvania, 1970), pp. 155-197.

⁶⁴Gimbutas' identification of Kurgan culture with the long sought-after Proto-Indo-European peoples is the most recent of a series of solutions to the I-E problem. See J. P. Mallory, "A History of the Indo-European Problem," Journal of Indo-European Studies 1: 21-65, for a review of those solutions.

The salient points of the theory on which her solution is based are as follows:

1.) Words exhibit genetic relationships (of form) explainable only by postulating a common 'ancestral' language termed Proto-Indo-European (P-I-E).

2.) Words like archaeological sites can be analysed to reveal levels of cultural information depicting chronological, geographical and social facts of life of the people who used the language (linguistic paleontology).

3.) That semantic information can be related to archaeological materials in order to determine prehistoric information about the language families.

On the basis of this theoretical structure, P I-E was attributed to the neolithic period (Marija Gimbutas, "On the Origin of North Indo-European," American Anthropologist 54 (1952): 602-610) of the South Russian steppes north of the Black Sea. Once the area had been identified, it was assumed that the people inhabiting it at that time, had to be undifferentiated Proto-I-E's. Their cultural expansion and growth was identified with the expansion of the Indo-Europeans. Hence Kurgan expansion into the Danubian area (c. 3500 B.C.) marked the first movements of I-E's out of the Urheimat (homeland). There is, of course, no linguistic information to support this contention. It depends entirely of the equation, culture = language, which is controversial at best. On the basis of wide divergences in our modern world of cultures which speak identical or nearly identical languages, I cannot personally accept the concept of I-E or P-I-E culture.

When ethnography is brought into the picture complete with the measurement of skeletal remains for the purpose of

tracing the distribution and movement of 'racial' types the theory comes very close to that formulated by the Third Reich (see Rao, Lothal, pp. 153-160; and Robert W. Ehrich, "Some Indo-European Speaking Groups of the Middle Danube and the Balkans: Their Boundaries as Related to Cultural Geography Through Time," Cardona, Hoenigswald, and Senn, eds., Indo-European, pp. 217-251.) Ehrich moves freely between the concepts of culture, language, and ethnic group in order to span the gaps in the history of the area he studies. Rao actually equates race and language group, although somewhat apologetically.

⁶⁵Blegen, Troy and the Trojans, pp. 110-113, 140, 143, 145-146.

⁶⁶Ibid.

⁶⁷The svastika could not have been brought to India for the first time in the hypothetical Indo-European invasion of the Indus Valley. Nor could that "invasion" account for the use of the symbol on seals rather than painted pottery. The "invasion" may not even be able to account for itself. The entire theory is coming under increasingly strong attack and no longer fully satisfies as an explanation of the "end of Harappan civilization." See, Fairervis, Roots of Ancient India, pp. 296, 301, 302, and 310; George F. Dales, "The Decline of the Harappans," Old World Archaeology, ed. C. C. Lamber-Karlovsy, pp. 157-164; and Robert S. Raikes, "The End of the Ancient Cities of the Indus," American Anthropologist 66 (1964): 284-299.

⁶⁸A. Ghosh, ed., Indian Archaeology--A Review 1959-60 (1960): 11-12. The author describes the inscriptions on page 11:

"The graffiti comprised, besides svastika, arrow-designs, grids and patterns of multi-pronged comb-designs, stylized animals often in rows."

⁶⁹Hyla Stuntz Converse, "The Agnicayana Rite: Indigenous Origin?", History of Religions 14 (1974): 81-95.

⁷⁰Ghosh, Indian Archaeology, pp. 11-12.

⁷¹Converse, "Agnicayana," p. 82.

⁷²Ibid., pp. 83-84.

⁷³Rao, Lothal, p. 95.

⁷⁴Hasmukh Dhirajlal Sankalia, Bendapudi Subbarao, and Shantaram Balchandra Deo, The Excavations at Maheshwar and Nardatoli, 1952-3 (Poona: Baroda, 1958), p. 167.

⁷⁵Dyson, "Relative Chronology of Iran," p. 220.

⁷⁶Fairservis, Roots of Ancient India, pp. 217-239.

⁷⁷Winn, Signs, pp. 34, 90, 122.

⁷⁸M. E. L. Mallowan, "Excavations at Brak and Chagar Bazar," Iraq 9 (1947).

⁷⁹Rao, Lothal, pp. 119, 120, 163-165.

CHAPTER 3

Interpretations of the Svastika

I. Introduction

The greatest problem involved in the interpretation of the svastika is the diversity of learned opinion about the nature of the symbol. Most scholars' arguments are well reasoned and cogent. Many are objective and convincing. But while all of the explanations fit some of the uses of the svastika; and some fit most; none of them fit all of the cases. After reading them I felt similar to J. B. Waring, an early commentator on the symbol, who wrote:¹

But neither in the hideous jumble of Pantheism--the wild speculative thought, the mystic fables, and perverted philosophy of life among the Buddhists--nor in the equally wild and false theosophy of the Brahmins, to whom this symbol...is ascribed...nor yet in the tenets of the Jains, do we find any decisive explanation of the meaning attached to this symbol, although the allegorical meaning is indubitable.

The svastika is the Rorschach-test of symbols. Peer into it and tell me what you see--each individual will give a different answer. Greg,² who thought it was derived from the lightning bolt, saw in the svastika the God of Thunder, Thor and Indra. D'Alviella saw the face of the sun (and the

Legs of Vishnu).³ Colley March saw the vast, rumbling, star-sprinkled vault of Heaven rotating around the Pole.⁴ Mackenzie saw the Four Corners of the Cosmos and the gods as they stood watch there.⁵ Goodyear saw the Lotus;⁶ and Burton viewed the svastika as nothing more than a simple scroll pattern.⁷ Madame Blavatsky, the founder of the Theosophical Society, saw "the evolution of the Kosmos, and the whole period of the twilight before Dissolution."⁸ Adolf Hitler saw the "mission of the struggle (Kampf) for the victory of Aryan man."⁹ Thomas Wilson at the turn of the century summed up the speculation in this way:¹⁰

In the estimation of certain writers it has been, respectively, the emblem of Zeus, of Baal, of the sun, of the sun-god, of the sun-chariot of Agni the Fire-god, of Indra, the rain-god of the sky, the sky-god, finally, the Deity of all Deities, the Maker and Ruler of the Universe. It has also been held to symbolize light or the god of light, of forked lightning, and of water... In the estimation of others, it represents Brahma, Vishnu, and Siva, Creator, Preserver, and Destroyer... It stood for Jupiter Tonans and Pluvius of the Latins, and the Thor of the Scandinavians...

II. The Solar Svastika

Out of all these possibilities and "wild speculations" --this "hideous jumble" of scholarship--one explanation of the svastika is most often favored: the solar svastika. E. Wallis Budge, d'Alviella, Max Müller, and many others

settle for that interpretation. In Amulets and Talismans Budge gives a similar list of meanings and then remarks that:¹¹

The generally accepted view now seems to be that it is a solar emblem, and that the short lines at right angles to the arms indicate gyratory or wheeling motion.

The roots of this idea of the svastika go back to the school of "Solar Mythology" espoused by Max Müller. It was to Müller that Schliemann appealed for an interpretation of the numerous svastikas he had found in the ruins of Troy. The answer given by the great German comparativist still echoes through the scholarship of the symbol. I quote:¹²

Quite another question is, why the sign should have an auspicious meaning, and why in Sanskrit it should have been called Svastika.... A remark of yours (Schliemann) in your book on Troy, where you speak of the Svastika as a wheel in motion, the direction of the motion being indicated by the crampons, contains a very useful hint, which has been confirmed by some important observations of Mr. Thomas, our distinguished Oriental Numismatist. He has clearly proved that on some of the Andhra coins, and likewise on some punched gold coins, depicted in Sir W. Elliot's Plate IX, Madras Journ. Lit. and Science, vol. III, the place of the more definite figure of the sun is often taken by the Svastika, and that the Svastika has been inserted within the rings or normal circles representing four suns of the Ujjain pattern on coins. He has also called attention to the fact that in the long list of the recognized devices of the twenty-four Jaina Tirthankaras the sun is absent; but that while the 8th Tirthankara has the sign of the half-moon, the 7th Tirthankara is marked with the Svastika, i.e. the sun... Here then I think that we have very clear indications that the Svastika, with the hands pointing in the right direction, was originally a symbol of the sun, perhaps the Vernal sun as opposed to the autumnal sun, the Sauvastika, and therefore a natural symbol of light, life, health, and wealth.

I for one do not find it surprising that Müller would have come to that conclusion. The tendency is evident in his other writings to see the sun in nearly everything:¹³

Was not the sunrise to man the first wonder, the first beginning of all reflection, all thought, all philosophy? Was it not to him the first revelation, the first beginning of all thought, of all religion?

No one would think to deny the sun a place in the mind of man, and a high place at that. But to ascribe to its influence "all reflection, all thought, all philosophy, all religion" is certainly going beyond reason itself. Even if I were to concede to Müller his implicit assumption that a first sunrise occurred suddenly to a first man at the dawn of reason, I could not concede that other implication--namely that throughout the whole long and fearful night preceding that dawn, that first man did not gaze on the vast panoply of stars and reflect, or philosophize--or even pray!¹⁴

D'Alviella follows quite closely the argument of Müller even while affirming his own "a priori" reasoning.¹⁵ After citing the absence of the sun among the list of Jainist Tirthankaras, and the numismatic argument, he adds:¹⁶

This, in brief, is the whole theory of the Gammodian ...founded on the following considerations:

- A. The form of the Gammodian.
- B. The connection between the tétrascéle and the triscéle.
- C. The association of the Gammodian with the images, symbols, and divinities of the sun.
- D. The part it plays in certain symbolical combinations, when it sometimes accompanies and sometimes replaces the representation of the solar Disk.

D'Alviella's point on "form" is only that the arms of the svastika are "rays" in motion.¹⁷ But the arms of the svastika portray rotary motion--an idea not usually associated with the sun. It should also be pointed out that the sun is often symbolised without rays--as a circle. D'Alviella himself notes that it is the circle which portrays the sun (rather than the rays, which are secondary).¹⁸

Wilson deals with the second point by pointing out that the svastika is much older than the triscéle and, therefore, it could not be derived from that symbol.¹⁹ His point is especially well-taken in the light of research that has gone on since both men wrote.²⁰

As for the association of the svastika with "the images, symbols, and divinities of the sun", it proves nothing. Wilson rightly rejects the proposition that association implies the equivalency of meaning. Association implies only that a relationship exists, but there are many relationships which do not imply equivalency. In fact, the appearance of the svastika on or alongside a sun-symbol, seems to indicate that there is some difference between them. Otherwise, why have two symbols? D'Alviella is certainly correctly stating the case when he writes,²¹

amongst the symbols accompanying the Gammodian, there is none so frequent as the Solar Disk.

But, to conclude from that evidence that there is no difference

between the two symbols is certainly going too far. Greg, also, was unable to accept d'Alviella's conclusion:²²

The swastika, even if used in a solar sense, must have implied something more or something distinct from the sun, whose proper and universal symbol was the circle.

Only d'Alviella's fourth point remains, and only the latter half of that. The first half--the "accompagnement" of sun symbols by svastikas--was just dealt with. His argument for what is left rests on the collection of objects which he calls Plate II (our Appendix 4, figures 1-23).²³ According to d'Alviella, they are all sun-symbols. In order to explain them, he employs another symbol (Appendix I, figure 24), which he terms the "Cosmic Tree of Hindu Mythology."²⁴ It represents, for the author, "the Three Steps of Vishnu,"²⁵ the three stations of the sun, and the triskelion (from which he derives the svastika). In all of the figures of part A (Plate II), three circles are supplemented by a fourth as in the tree with three suns and a fourth behind the trunk. Part B (Appendix I, figures 8-23) show the sun during the four seasons.²⁶

The criticism of this argument notes, first of all, that d'Alviella relates the "Three Steps of Vishnu" to the positions of the sun when they might be more correctly described as marking the three levels of Vedic cosmology.²⁷ In this respect the three circles surrounding the fourth depict the three levels of the world surrounding the axis

mundi, whose base is the altar and whose summit is the lofty pinnacle of heaven.²⁸ Part B is then explained to mean that the axis mundi is surrounded, horizontally, by the four regions of space.

Second, d'Alviella assumes the priority of the triskelion, and its relationship to the svastika. Third, he makes no attempt to account for the fact that a similar mythological idea is adduced to explain symbols from two widely separated cultures. Because he believed that the svastika spread to India from Troy, he saw no need to justify this breach of method. But, his assumption has proved unsound, and his conclusions need to be re-assessed.

All this is to say that d'Alviella's interpretation of the svastika as a sun-symbol rests entirely upon outdated information and unproved assumption. He admits that his conclusions are "hypothetical"²⁹ while Wilson of course goes further in his criticism:³⁰

It is surely pushing the argument too far to say that this is an 'incontestable' representation of solar motion.

The final argument for the solar character of the svastika is mentioned by both Müller and d'Alviella. It involves a coin from Thrace which bears this legend: MES ☸. The translation is variously rendered as "Mid-day" or "The Town of Noon";³¹ "The town or city of the South, or the sun."³² This proves the interpretation of the svastika as

a sun-symbol, argue the two scholars, since the symbol is used to replace the sun in the inscription! Not so! MES is related to the Greek meso, "middle," and it remains un-supplanted by the svastika. They might as well have argued that the svastika stood for "town."

A similar coin appears in India bearing the legend, Majhamikaya-Sibi-janapadasa. As in the Thracian coin a svastika precedes the inscription. "The Middle Country of the Sibi"³³ is a fair translation of the legend and it illustrates the role of the svastika--on both coins--as a symbol of the centre. Since this coin is dated to the 4th-2nd centuries BC it falls into the Alexandrian period and the similarity between the two coins may be more than simply coincidental.³⁴

This, then, is the basic case for interpreting the svastika as a solar symbol. Often hypothetical, conjectural, and wildly speculative, the theory has yet to be proved. Yet it seems ineradicable and one meets with it at every turn of the page. It clings to the mind, and lingers in the soul, where the lamps of scholarship burn, sometimes, dimly.

The theory is with us even today, in Walker's Hindu World,³⁵ in Pusalker's article in The Vedic Age, and elsewhere.³⁶ Two articles written for The All-India Oriental Congress in the 1970's argued in favor of the solar theory

of the svastika.³⁷ Survey books on art and symbolism accept the theory as a fact beyond dispute.³⁸

But it must be disputed. It is no more accurate to describe the svastika as a sun-symbol, than as the emblem of Zeus, or Indra, or even, of Hitler. Another explanation must be found.

III. The Role of the Svastika

Now that Müller's school of "Solar Mythology" is in "eclipse,"³⁹ it is appropriate to reassess the significance of the symbol. A more conclusive (and inclusive!) explanation might be found. The fund of information has grown larger and the methods for study are more sophisticated than they were a hundred years ago. New disciplines have arisen (depth psychology, anthropology, linguistics) which offer a new perspective on the study of symbols and a wider context in which to understand religion. Wherever possible, that information, and those methods have been used, in this paper, in order to understand the svastika in the full breadth of its context.

Traditionally, the svastika has been studied in isolation, stripped of the cultural matrix which gave it vitality. Studies of that sort have largely been autopsies of symbols--investigations of its lifeless corpse. Conse-

quently, the results were often lifeless. Religious and symbolic values disappear when the symbol is removed from its vital network of social relationships, and the meaning of the symbol recedes from view. Imagine trying to understand the Christ experience with no knowledge of its Hellenic environment; or the Christian cross only through a tabulation of its history as a symbol.⁴⁰

The same is true of the svastika, as a symbol. It is a stellar example of the incomprehensibility that masks the meaning of a symbol that has been removed from the symbolic context within which it once existed. It becomes plastic, capable of being formed, or twisted, into any shape whatsoever. It is no wonder that opinions have varied so as to the meaning of this ancient symbol. So--the reconstruction of the symbolic environment is what this paper is about.

It is, of course, absurd to attempt to recover all of the details of a thousand times and places where the svastika has been used as a symbol. Ten thousand reams of written discourse could not restore what 8000 years have erased. The most that can be hoped for is that we shall be able to perceive dimly the bare outlines of the symbolic complex; that the "pattern" (as Eliade would have it) is still intact; or that the "structure of the hierophany" has remained constant even though its outward forms have changed.⁴¹

In other words, what will be sought for here will not be the meaning of the svastika--but its role (the part it plays in the drama of human religious life) in the framework of experience.

Meanings are specific, and historically conditioned, Roles are general or generic, and stem from the human condition. As a result they tend to the universal and accept many symbols as their agent of expression. Roles are the script--symbols are the actors which bring it to life and expression. Many actors may play a single role bringing to it his own interpretation and style. So also many symbols may fulfill a role, and thereby bring it to life. That interaction of the symbol and the role is what I seek to understand. The role has the quality of Reality, and therein are the real roots of the svastika to be found.⁴²

Jung's "empty forms" (the archetypes) are analogous to roles. They both present the possibility of a "certain type of perception and action."⁴³ As "empty forms" they (roles) may be accurately characterized as nameless--or as experience which seeks a name. They exist before and beyond language, like birth and death. Because of their pre-nominal nature they are experiences which are capable of being expressed or handled only through a matrix of non-linguistic signs--through symbols.

The svastika is such a symbol. Created by direct

experience it fulfills a role consistent with all human activity. It designates the space of prenominal experience. It expresses symbolically (without words) perceptions and actions which took place beyond the "edges of language",⁴⁴ in what Eliade called illud tempus--mythic time.⁴⁵ Thus symbols derive their mythic qualities and their religious uses from the role they play. These qualities may be passed on from symbol to symbol as historical circumstance dictates changes in the symbolic cloak of the role. In this way Vishnu, may absorb some to the qualities of Indra as each assumes the role of creator. For instance, Indra, the slayer of Vrtra, looses the cosmic fertilizing waters of creation according to the RgVeda, but in the Puranas Vishnu, in his third and highest step, catches his toe in the peg of heaven and rips a hole in the firmament out of which flow the waters of creation.⁴⁶ The Nāgas who support the universe are later translated into elephants.⁴⁷ Svasti, a Vedic goddess of Prosperity is later absorbed by Lakshmi, and so on. Eliade has described one part of the pattern:⁴⁸

Supreme Beings of a heavenly nature tend, if they do not fade into complete oblivion, either to change into gods of fecundation and weather, or else become sun gods.

Structures of sacred time and space are not bound by geographical-cultural-historical ties. They need not be diffused. As a result of the human condition they arise independently among North American Indians, Mayans or Aztecs,

Chinese, Swedes, Greeks, or Hebrews. As structures beyond language they are not limited to a single language-group, i.e. Semitic, Finno-Ugritic, or Indo-European.

The universal distribution of the roles is not matched by a similar distribution of any one symbol which fulfills the role. Chapter 2 showed that the svastika began as a localized symbol having an established meaning among the Samarrans, but without value to their Halafian neighbors. By the time of the Iron Age the svastika was widely distributed throughout the Old World. The simplicity of the design and the efficiency with which it expresses the concept of the axis mundi undoubtedly led to such a wide acceptance. But among some, it was rarely used. The Egyptians had a different symbol which expressed the concept, as did the early Indo-Europeans.⁴⁹ Since all of the symbols express the same concept I call them surrogates of each other. They are the actors among whom the svastika is the "Barrymore".

Loewenstein⁵⁰ and d'Alviella both approached a delineation of this idea of surrogates in their works on the svastika. Loewenstein saw the Old World as divided into two spheres⁴¹ in terms of symbolic ornamentation-- north and south, patriarchal and matriarchal, rectilinear and curvilinear.⁵²

The "Southern or Matriarchal Cultural Sphere"... extended from the Near East in a north-westerly direction as far as Central Europe, including the southern part of modern Poland and the Ukraine... The important thing to establish is that the Swastika, like female idols, occurs in all the groups of the great "Southern Sphere"... whilst it was originally quite unknown outside of it.

D'Alviella, whose perception was the same in general, came to different conclusions because he was arguing from a different set of facts. He wrote 50 years before Loewenstein and before Herzfeld's discovery of the svastika in northern Mesopotamia. In 1894 he wrote:⁵³

In brief, the ancient world might be divided into two zones, characterized, one by the presence of the Gammodian, the other by that of the Winged Globe as well as of the crux ansata.

Both of these ideas have problems. For instance, d'Alviella cannot account for the discovery of the svastika in northern Mesopotamia. On the other hand, Loewenstein ignores the absence of the svastika from Egypt, Palestine, and Anatolia. What they have both correctly perceived is that the symbol is prevalent in some areas and absent in others where its role has been usurped by a surrogate. In Egypt, the winged disk is a svastika-surrogate identified with the solar cult.⁵⁴ In Minoan religion the labyrinth played the same role.⁵⁵ Tripolean symbols designating an identical idea are the spiral and the quartered lozenge (see Appendix 7, figures 6, 7, 9, 12, 13, and 14).⁵⁶ There are a number of symbols which have filled the role in the

Indian religious tradition, including the svastika, the lotus, and the tree.⁵⁷

Of all of the svastika-surrogates, the tree is probably the most wide-spread. It occurs in all parts of the world in a virtually identical fashion. Since it is so wide-spread, the outlines of the role it plays are better preserved in its cult than they are in others.

E. A. S. Butterworth⁵⁸ describes it as follows:

So begins a tale of the Yakuts of Siberia...
'Above the wide, motionless deep, under the nine spheres and the seven storeys of heaven, at the most central place, the navel of the earth, earth's stillest place, where the sun does not set and the moon does not wane, where eternal summer reigns and the cuckoo calls unceasingly, there the White Youth found himself.'

The story goes on to describe a great tree, set on a high mountain. Its roots are in the nether worlds and its top rises to the highest point of heaven. In the tree dwells a goddess who guards its ambrosial sap. Eliade regards this configuration of symbols as "one of the most common and constant patterns."⁵⁹ It is found in the Vedic tradition⁶⁰ and in the motifs of the Indus Valley seals.⁶¹

Effigies of the ficus religiosa are fairly numerous, as are those representing the Great Goddess naked--an iconographic motif common to chalcolithic civilization all over Afro-Asia, including Egypt. The sacred tree is in an enclosure, and sometimes a naked goddess rises between two branches of a ficus religiosa growing in the centre of a circle. It is clearly indicated in iconography that this signifies a holy place and a "centre."

The complex of symbols (or "pattern"), as it has been outlined by Butterworth and Eliade, consists of tree, goddess, and animal. Each plays a role. Each seeks to describe symbolically "mythic" experience--pre-nominal perceptions and actions. The role of the tree is that of the "centre"--of the world, of the universe, and of human existence.⁶² It marks "the most central place, the navel of the earth, earth's stillest place."

The svastika, like the mountain, the tree, the lotus, or the labyrinth, is a symbol of the role of sacred space.⁶³ Its central point represents the fixity of that space; its arms are the extension of space in all directions from that point; the hooks convey the symmetry of rotation inherent in the idea of the axis mundi.⁶³ In its most basic significance at the morphological level, the svastika represents the concept of devotion: attachment to and movement about the internalized centre. Ritually, the circumambulation of the altar is an act of rotation about the centre. Mythically, the "heavenly host," the devas, are devoted to, and revolve about, the Pole star.

Each of these ideas may be perfectly symbolized by the svastika.

IV. Summary

It is not possible to attribute any single meaning to the svastika. Characterising it as the symbol of "the victory of Aryan man" is no more, nor less, correct than describing it as a "sun symbol." There is some evidence for most of the views that have been offered, but no conclusive evidence for any of them. The most widely accepted interpretation is that the svastika is a sun-symbol. But the arguments for the solar theory are hypothetical and out-dated.

Since previous studies of the symbol have proved inconclusive, a new approach has been offered. By placing the svastika back into the context of its symbolic complex an understanding of its role in a cohesive configuration of symbols is made possible. Such an approach makes it possible to reconcile the various views rather than to refute them.

The svastika, when it is viewed in context, appears as one of a group of symbols which express the role of the "centre." As a symbol of sacred space, the svastika is associated with many other symbols and figures of religious and mythic dimensions, i.e., Indra, Thor, and the sun. Those associations led to the various interpretations of the symbol through the proposition of equivalency of meaning through association. This theorem has been rejected in favor of one

that views associations as complementary.

The following chapter enlarges upon this view of the svastika.

NOTES

¹J. B. Waring, Ceramic Art in Remote Ages, p. 12, as quoted in Wilson, "The Swastika," p. 775.

²Wilson, "The Swastika," p. 779.

³Ibid. See also d'Alviella, Migration of Symbols, pp. 52-55.

⁴Quoted in Wilson, "The Swastika," p. 781.

⁵Mackenzie, Migration.

⁶Goodyear, Grammar.

⁷Quoted in Wilson, "The Swastika," p. 780.

⁸Katherine Hillard, An Abridgement of 'The Secret Doctrine; A Synthesis of Science, Religion, and Philosophy, by Helena Petrova Blavatsky (New York: The Quarterly Book Department, 1907), p. 515.

⁹Adolf Hitler, Mein Kampf, trans. Ralph Manheim (Boston: Sentry; Houghton Mifflin Co., 1971), p. 497.

¹⁰Wilson, "The Swastika," pp. 770-771.

¹¹E. A. Wallis Budge, Amulets and Talismans (New York: Collier-Macmillan, 1970), pp. 331-335.

¹²Max Müller, As quoted by Wilson, "The Swastika," p. 773.

¹³Max Müller, as quoted by A. Smythe Palmer, "Introduction," Comparative Mythology, Max Müller, with "The Oxford Solar Myth," by R. F. Littledale (London: George Routledge & Sons, n.d.), p. xi.

- ¹⁴ Littledale's essay is a beautiful spoof on the methods on Müller. He treats Müller and his life as if they were symbols of the sun.
- ¹⁵ D'Alviella, Migration of Symbols, pp. 52-57.
- ¹⁶ Ibid., p. 52.
- ¹⁷ Ibid., pp. 52-53.
- ¹⁸ See my discussion on the morphology of the svastika in Chapter 1.
- ¹⁹ Wilson, "The Swastika," pp. 790-791.
- ²⁰ See Chapter 2 of this paper. Especially, on the svastika in northern Mesopotamia and Iran.
- ²¹ D'Alviella, Migration of Symbols, p. 56.
- ²² Wilson, "The Swastika," p. 790.
- ²³ D'Alviella, Migration of Symbols, p. 60 (facing).
- ²⁴ Ibid., p. 61.
- ²⁵ Ibid.
- ²⁶ Ibid., pp. 60-65.
- ²⁷ Ralph T. H. Griffith, The Hymns of the RgVeda, Chowkhamba Sanskrit Studies Series, no. 35, 2 vols. (Varanasi, India: Chowkhamba Sanskrit Series Office, 1963), 1: 127.
- ²⁸ Mircea Eliade, Patterns in Comparative Religion, trans. Rosemary Sheed (New York: Meridian; New American Library, 1974), pp. 99-104.
- ²⁹ D'Alviella, Migration of Symbols, p. 65.
- ³⁰ Wilson, "The Swatika," p. 787.

- ³¹D'Alviella, Migration of Symbols, p. 59.
- ³²Wilson, "The Swastika," p. 788.
- ³³John Allan, Catalogue of the Coins of Ancient India (London: Trustees of the British Museum, 1967), p. cxxiv. The translation is Allan's, not my own.
- ³⁴Ibid.
- ³⁵Benjamin Walker, Hindu World, 2 vols., s.v. "Swastika."
- ³⁶A. D. Pusalker, "The Indus Valley Civilization," The Vedic Age, The History and Culture of the Indian People series, no. 1, gen. ed., R. C. Majumdar (Bombay: Bharatiya Vidya Chavan, 1965), pp. 172-204.
- ³⁷Bhaskar Chatterjea, "Iconographic Development of the Sun-God in Early North India," Proceedings of the All-India Oriental Congress, 27th session (1976): 409-413.
Joshi, "Svastika--."
- ³⁸Such as Goff and Akurgal (see Bibliography) whose books rely heavily on interpretations of other scholars.
- ³⁹Richard Dorson, "The Eclipse of Solar Mythology," Myth: A Symposium, ed. Thomas Sebeok, Bibliographic and Special Series of the American Folklore Society (Philadelphia: Indiana University Press, 1972).
- ⁴⁰The 'event' of the Cross has contributed as much to the meaning of the symbol as did its entire history prior to that time. But, still, the Cross drew on that history for some of its power as a symbol.
- ⁴¹Eliade, Patterns, pp. 1-10.
- ⁴²Ibid., pp. 429-431.
- ⁴³Carl Gustav Jung, The Collected Works of C. G. Jung, 19 vols., trans. R. F. C. Hull (London: Routledge & Kegan Paul, 1968) 9: 48.

⁴⁴Paul M. Van Buren, The Edges of Language: An Essay in the Logic of a Religion (London: SCM Press, 1972).

⁴⁵Mythic time expresses a discontinuity with ordinary time. Eliade understands this in terms of a historical consciousness versus a mythic consciousness. Perhaps we agree. I view language as the categories of history, and history as the ground of logic.

⁴⁶Griffith, RgVeda, 2. 12. 3.
Nali Nath Muherji, Popular Hindu Astronomy, with a Foreword by N. G. Lahiri (Calcutta: Nirmal Mukherjea, 1969), p. 20.

⁴⁷On the decline of the Sky-God in cult and the rise of the Storm-god, the Rain-god, etc., see Eliade, Patterns, pp. 38-123.

⁴⁸Eliade, Patterns, p. 139.

⁴⁹On the use of the spiral in early Indo-European religion, see Gimbutas, "Proto-Indo-European Culture," and B. A. Rybakov, "Cosmogony and Mythology of the Agriculturalists of the Eneolithic," Soviet Anthropology and Archaeology 4 (1965): 16-38.

⁵⁰Prince John Loewenstein, "Swastika and Yin-Yang," Nine Dragon Screen: Being Reprints of Nine Addresses and Papers Presented to the China Society, 1909-1945 (London: The China Society, 1965), pp. 5-28.

⁵¹Ibid., pp. 24-25.

⁵²Ibid., p. 24.

⁵³D'Alviella, Migration of Symbols, p. 82, and chart facing p. 80.

⁵⁴Ibid., p. 82.

⁵⁵Eliade, Patterns, pp. 380-381.

⁵⁶Rybakov, "Cosmology and Mythology," pp. 20-24.

57 The evidence for the surrogate-nature of these symbols would fill a book in itself. But see Zimmer, Myths and Symbols in Indian Art and Civilization. Note also that the posture known as Padmāsana is also known as Svastikāsana; that in the Vedas the altar area is described in many ways-- as a tree, as a horse-stake, and so on.

58 E. A. S. Butterworth, The Tree at the Navel of the Earth (Berlin: Walter de Gruyter & Co., 1970), p. 1.

59 Eliade, Patterns, pp. 280-286.

60 Eliade, p. 281. "This conception is firmly rooted in both Vedic and Puranic creation beliefs..."

61 MacKay, Further Excavations, vol. 2, "Plates." Fairservis, Roots of Ancient India, pp. 274-285.

62 Jung sees that in the representation of human experience the whole spectrum cannot be expressed in terms of anthropomorphic symbolism, the rest must find expression in some other way.

"Only part of the self can be expressed by human figures: the other part of it has to be expressed by objective, abstract symbols." Jung, Collected Works, 9: 187. He goes on to mention both theriomorphic and plant figures specifically. "These lead to geometrical figures like the circle, the sphere, the square, the quaternity, the clock, the firmament, and so on."

63 See the morphological analysis in Chapter 1.

CHAPTER 4

The Svastika: A Symbol of the Centre

I. Introduction

2

The primary source for the task of understanding the prehistoric svastika is archaeology. Only the relics of the ancients can supply the keys to unlock the doors into the prehistoric imagination wherein lies the ultimate significance of the svastika. But the evidence is mute. A wall of silence separates the historic and the prehistoric periods from each other. The written languages of ancient man do not extend beyond the 4th millenium BC. They offer no clue to the meaning of the svastika. The earliest language-related use of the svastika comes from the Indus Valley in the 3rd millenium. That language remains untranslated.

Linguistic paleontology¹ provides little in the way of evidence on the early uses of the svastika. Svastika occurs only in Classical Sanskrit. It has no cognate in Old Persian or Avestan. Hungarian (a Finno-Ugritic language) has the word horogkereszt (lit., angled-cross) for svastika.² Like Hakenkreuz and Gammadion, horogkereszt is a descriptive term and supplies no inkling as to the meaning of the symbol.

Only the Navaho language contains a description of the svastika as a symbol. There the svastika is Tsinéole,³ the logs that whirl. The name and its explanation are found in the text of The Night Chant, A Navaho Ceremony, by Washington Matthews (quoted by Mackenzie):⁴

He beheld the cross of sticks circling on the lake. It did not move on its own centre, but turned around the centre of the water. The log which lay from east to west was at the bottom; that which lay from north to south was on the top. On each of the logs, four holy ones were seated--two at each end...

While the Navaho myth of the origin of the svastika may supply evidence for understanding its meaning in the area of the American southwest, other sources must be found in respect of the Old World. To that end modern religious practice, folklore, and textual materials become the secondary sources.

In an article on the interpretation of eneolithic Tripolyan ornamentation (c. 3000 BC), R. A. Rybakov notes:⁵

It is possible to trace connections through millenia from the Tripolyan art to the most archaic strata of the folklore of the Indians, Iranians, Slavs, Moldavians, and Lithuanians--connections that help us to decipher the symbolism of the ornamentation.

He gives an example of a Tripolyan vase which depicts a custom still practised in modern Bulgaria:⁶

Raising a vessel to the heavens is widely known in the rituals of many peoples and is always associated with fertility magic.

The Bulgarians have retained the practice of having the three

eldest women raise the New Year bread thrice to the skies; the ancient Slavs raised a trough filled with grain to the sky.⁷

This ritual was adopted by the Orthodox Church as the raising of the vessel containing the fermented sour bread blessed on the first day of Easter and given out to the people on the Saturday of Holy Week.

Another example of the use of modern folklore for the interpretation of ancient religious customs comes from Johannes Mariinger's article, "Grave and Water in Prehistoric Europe."⁸ The author notes that megalithic graves and monuments are located near water (lakes, springs, brooks, etc.), and that a series of horizontal and vertical zig-zag lines ("the commonly accepted ideogram for water") are engraved on them.⁹

Water undoubtedly played a prominent role in megalithic belief. Yet, so far as the author of this study knows, no explanation has been given for this striking topographical feature. On the grounds of much later folkloristic beliefs we may assume the megalithic builders believed that water was the abode of the dead.¹⁰

Still another example of the tenacity with which ancient ideas are retained in modern usage comes from India. In Bengal today the most important festival is the Durga-puja held in the autumn. Various members of the Durga-family are worshipped, including Ganesha and his wife Kalabau.¹¹ Kalabau, who was originally an agricultural deity,¹² is placed in front of the Bel-tree (Ficus religiosa) and worshipped either as the goddess Lakshmi, or for the invocation

of Durga.¹³ As such she is reminiscent of scenes from the seals of the Indus Valley which portray a goddess emerging from the ficus religiosa.¹⁴ When one adds to this configuration the presence of Ganesha with his elephant-head and his svastika-emblem-- also found on the Harappan seals-- the similarity is overwhelming. Even Śiva, the Lord of the Beasts, is portrayed on some seals.¹⁵

Another type of study can also help to decipher the meaning of prehistoric symbols. Archaeology has recovered a number of materials from the 1st millenium which can be related to what we know of the mythology of the culture from which it came. Such correspondences provide an intermediate link between very ancient material and modern usages.

In "Mythology in Mycenaean Art," Emily Townsend Vermeule¹⁶ is able to cross the void between history and prehistory--between Greece and Minoan civilization--through an analysis of art. One example given by her depicts the "Shield Goddess" of Mycenae (Potnia) in terms reminiscent of the later Athena. The correlation is helped by the knowledge that one of the local ^{cult} titles of Potnia was A-ta-na.¹⁷ Another example, from an Amethyst seal of Pylos, shows a warrior and a rearing lioness which puts one in mind of "Herakles and the Nemean beast."¹⁸

In the same vein, Rybakov analyses Tripolyan art in order to extract from it the concepts of the ancient agri-

culturalists. Interestingly enough the same designs, even the same arrangement of space, is preserved in pottery of the geometric period of Greek civilization.¹⁹

Symbols, such as the meander, the quartered lozenge, the lotus, and the svastika are the vocabulary of prehistoric civilization. They can and must be deciphered.

II. The Symbolism of Space

Sacred space of eneolithic Tripolye is symbolized vertically and horizontally, as Rybakov's analysis clearly shows.²⁰ The vertical space is tripartite while the horizontal is quadrapartite. Rybakov's conclusions are drawn from the material remains of a specific chalcolithic European culture, but they may be seen to apply equally well to many others as well.

Reference was made earlier to the Navaho conception in which the svastika appears. Mackenzie believes it to be a cross of the cardinal points.²¹ Villaseñor supports this view. He writes:²²

From the great center of life, four bars (elements) reach out to the four cardinal points of the compass...

Hodge describes it (the svastika) as a Navaho "Altar-floor symbol of the four world-quarters."²³

The same principle of horizontal quartering is evident

in the pottery of the Mimbres Indians (see Appendix 2, figures 18-29) as it is in Samarran ware. Very frequently, in both pottery styles, a svastika appears in the centre of the design. The style of the Trojan spindle-whorls is radically different than that of the painted pottery traditions, but the principle of quartering remains just as visibly present (see Appendix 7c). John Perry's book, Lord of the Four Quarters,²⁴ relates the concept of divine kingship to the quartering of the universe in Egyptian, Indo-European, Near Eastern, and New World culture (literally covering the four corners of the world!).

Rybakov, who believes that the "principle of four-fold repetition" did not appear before agriculture, considers it to be an "important landmark in cognition of the world."²⁵ The universal character of the phenomenon would certainly seem to support him in that view. Zenia Nuttall considers the quartering of the universe to be the cardinal idea central to all of the world's civilizations.²⁶ F. W. Putnam, the Curator of the Peabody Museum, summarized her conclusions as follows:²⁷

She traced the origin of the swastika in Mexico to an astronomical source, and in all countries alike, found its use as a sacred symbol accompanied by evidence of a certain phase of culture based on pole-star worship, which found expression in the ideal of celestial kingship or states organized on a set numerical plan and regulated by the apparent revolution of the circum-polar constellations.

Nuttall's conclusions follow quite closely those of Perry and Mackenzie, who wrote:²⁸

It would appear, indeed, that the spiral was a symbol of the Celestial whirlwind or whirlpool, and that was why it was associated with the cross, the symbol of the four cardinal points, and the swastika, the symbol of the revolving seasons controlled by the Great Bear.

Like Nuttall, Mackenzie believed that there was a strata of Pole-star worship which underlay the more recent cult of the sun-god.²⁹ They may well be right in that hypothesis, but a discussion of the point will have to be postponed for the moment.

Rybakov's second division of space as it is represented on Tripolyan painted pottery is vertical. Appendix 7, figure 20, portrays a vase on which a number of the elements identified by Rybakov are clearly visible.³⁰ Two heavy bands divide the body of the base into three zones. According to Rybakov (compare this description with figure 20 of Appendix 7):³¹

1. The upper band (at the neck of the vessel) usually contains the ideogram for water: a horizontal wavy line.
2. The middle and broadest band is filled with spirals, solar and lunar symbols, slanting lines and vertical treamer-types recalling rain.

In Figure 20 (Appendix 7) the spirals have been replaced by svastikas, and the rain-lines are absent.

3. The bottom band is very narrow. It consists of two parallel lines between which nothing at all is drawn. Sometimes one finds trees growing, or animal figures standing on the upper line of this band.

A number of basic differences occur in the vase illustrated, from the pattern outlined by Rybakov.

First, if the horizontal design (at the neck) be taken as the water ideogram which Rybakov describes in the first band, then rather than three levels, the vase has four. The first has the horizontal rain-design. The second shows a large lotus, faced on either side by what appear to be geese. Deer graze on third band which, according to Rybakov's plan, should be the ground level. Below that are more lotuses. According to Rybakov:³²

This threefold division is not invariable in all types of compositions, ... In one case we will find a doubling of the earth and in the upper sky we see clearly terrestrial elements such as ears of grain or animals. In another case we will find a doubling of the middle sky with its solar spirals.

The vase in figure 20 clearly fits into the pattern as Rybakov gives it. All the more remarkable is this similarity when one realizes that the vases which the author describes and this one are separated in time by nearly 2000 years! The vases described by Rybakov were produced in the Ukraine c. 3000 B.C. while the vase pictured in Figure 20 is a Rhodian vessel of the Greek Geometric Style (c. 600 B.C.). Both could clearly be described as Indo-European.³³ Here is clear evidence of a number of key points:

1. The svastika and the spiral are "surrogates."
2. The svastika does not appear in the Early Indo-European vase because the spiral was filling that

role.

3. The svastika is not originally Indo-European, but was picked up during their movement to Greece.

The replacement of the Indo-European spiral by the svastika on the Rhodian vase is a stark contrast to the traditional character of the other symbols. Appendix 7 (figures 1-19) reproduces a portion of the Tripolyan repertoire of design motifs. Some of them appear essentially unchanged on the vase from Rhodes. For instance, the quadrapartite symbols floating over the deer are modifications of figure 12. Each is divided into four parts containing a dot. The pyramidal designs growing out of the heavy bands (and hanging from the upper one) resemble figures 6, 7, 9, 13, and 14-- though they appear only partially visible. A large lotus in the third band is blooming out of one of the half-buried lozenges. The lotuses which, according to Goodyear, are an Egyptian motif,³⁴ are clearly a foreign element in Rybakov's analysis--unless one is willing to believe that lotuses grew in the Ukraine in 3000 B. C.

Rather than "potential" lotuses, Rybakov describes the lozenges as fertility ideograms.³⁵ He describes a number of female statuettes which bear this ideogram as a protective device around the navel; its use in 20th-century wedding shirts and skirts; on Rhodian vases; and a 19th-century Belorussian use:³⁶

when a new house was built, a square of this type was first drawn on the ground. Then the head of the family visited each of the four fields around the farmyard, and brought from each a rock carried on his head, which he then placed in the centre of each quarter of the square.

Rybakov believes that this ideogram is a pictograph of a plowed field in which seeds have been planted. It has a remarkable resemblance to symbols which occur on Trojan spindle-whorls (see Appendix 1, figure 42). It is called a Croix Swasticale from its resemblance to svastikas which occur with a dot in each quadrant.

In Gujarat a similar custom prevails in which fertility, ploughing and the svastika are related.³⁷

On the day when ploughing is to be commenced, the front court yard of the house is cowdunged and an auspicious figure called Sathia (svastika) is drawn on it with the grains of juvari.

Even the lotus is a symbol of fertility. In India, it is connected with Lakshmi, the Goddess of Prosperity. Among her epithets are, "lotus-born," "standing on a lotus," "lotus-coloured," "lotus-thighed," "lotus-eyed," "abounding in lotuses," and "decked with lotus garlands."³⁸ The seat, or the throne, of the gods is also a lotus.³⁹ As such it is not only connected with the earth and fertility, but with the "highest and the best"; it is, according to the Jainists, "like Svastika and Vardhamanaka amongst the Celestial Regions."⁴⁰

The four quadrants of space which extend outward from

the centre, and the three levels of vertical extension should not be viewed as separate provinces. They are a unified whole which is joined by the axis mundi. Its base is on earth and its pinnacle is usually at the pinnacle of heaven.⁴¹ On each level the centre is represented in analogous terms. For instance, on the vase pictured in figure 20, the lotus is the central symbol. It is represented on each level. In the lowest level, the blossoms have died, only the leafy plants remain. According to Rybakov, this area represents the nether-world. In the Tripolyan material, it is blank.⁴² On the second level where deer are grazing the lotuses remain potential. This is the earthly plane. In the sky, where the geese are, the lotus has bloomed. Above that lie only cosmic waters associated with creation.⁴³ Goodyear notes that the lotus⁴⁴ topped Egyptian columns and was frequently associated with the goose. As such the lotus-column is associated with the sky-pillars which extend to the "roof" of heaven in Egyptian mythology.⁴⁴

The blossoming of the lotus from the half-lozenge provides a graphic illustration of the "surrogate-nature" of the two symbols. In the Rhodian vase with its Egyptian influence the lotus participates in the role of the centre, and the lozenge has been relegated to a secondary status as a supportive fertility symbol. The artistic representation reflects the historical transition from one idea to another.

The symbols change, but the role remains the same. It is the centre out of which creation proceeds. It may be symbolized by a lotus, a lozenge, or a svastika.

Probably the best example of the process of surrogation is seen on a series of coins which were found in Knossos (Crete).⁴⁵ Minted during the 5th-4th century B.C. the coins bear on one side the head of the Minotaur. On the obverse, various symbols occur, including the labyrinth, the svastika, and a square divided into nine parts. Each of these symbols fulfills the role of the centre. The svastika usually occurs in the centre of the labyrinth, or in the central square of the compartmented design. At other times, instead of a svastika, five points are arranged like an X or a star.

The role of the svastika in this configuration stems from the well-known story of Theseus' slaying of the Minotaur.⁴⁶ The myth recounts a familiar theme: a god or a hero slays a monster, and restores order. Vṛtra is slain by Indra (or Vishnu) and the life-giving waters are released. Marduk kills Tiamat. Eliade rightly detects in this version of the complex, "the quality of an initiation."⁴⁷ It takes place at a "centre" guarded by a serpent and a monster.

The svastika is, in the words of A. B. Cook, a "symbol" of the labyrinth of Knossos. A sherd from a vase shows this relationship by depicting the Minotaur emerging from behind a column decorated with svastikas.⁴⁸ Describing the

earliest labyrinth designs on Cretan coins, A. J. Evans notes that they are "little more than a slight development of this symbol."⁴⁹ The relationship between labyrinth and svastika is suggested elsewhere as well.

The elaborate design of the Jainist nandyavarta (Appendix 1, figure 53) is a truly labyrinthine svastika, as is that depicted in figure 21. The literature on this strange figure is obscure, but its association with the "Whirlpool" and the "Nine Treasures of Kubera," suggests an image not unlike that of the Navaho "Whirling Logs." What is significant is that the svastika, the nandyavarta and the labyrinth are each variously described as buildings.⁵⁰ They might be more accurately understood as a place--the sacred space of the centre, the place of initiation.

But it is through the figure of the divided square that the symbolism of space is most clearly brought out. The "nine-chambered" square is a surrogate of the labyrinth as well. It is also known as "the Magic Square of Three" because of its mathematical qualities. By placing a number in each of the nine squares according to a particular arrangement, each of the rows, horizontal, vertical, and diagonal will add up to 15. Similarly, if each of the paths of the Knossos labyrinth is numbered consecutively from 1 to 9 both ways from the centre, the distribution of numbers in the magic square is achieved.

There are other similarities between the labyrinth and the square of nine compartments, but one must go to China and Chinese legend to discover them.⁵¹ There, the Great Yu (a legendary king) first discovered the Magic Square on the back of a turtle rising out of the River Lo. Cammann and Needham both give detailed descriptions of the use of the diagram in Chinese art, religion, and politics, but let suffice to say that it is the model upon which the Chinese conceive the universe. The nine squares represent the divisions of the Chinese state at the centre of which is the residence of the emperor. Directly overhead of the central square is the pinnacle of heaven, the throne of the sky-god T'ai-Yi.⁵² The eight other squares are represented in heaven as the four cardinal points and the four intermediate directions. As in so many other areas,⁵³ the emperor below is identified with the god above. In China, the nine regions also take the form of a svastika.⁵⁴ Christenger's comment is:⁵⁵

Thus there is an equivalence with the coins of Cnossos. But what precisely is the imago mundi revealed to Yu the Great by the turtle? It is the image of the Universe traveled through by T'ai Yi, "the Supreme Unity," whose carriage is formed by the bowl of the Great Bear constellation, the handle of the Great Bear being the spear of T'ai Yi.

Again we are reminded of the contention of March, Nuttall, and Mackenzie--that the svastika is a graphic representation of the circumambulation of the Great Bear (or Big

Dipper) about the Pole star.

III. Weaving and the Svastika

In chapter 2 a brief discussion of weaving and the svastika brought out the dependency of early Samarran and Mimbres pot-makers on weaving techniques. I also mentioned the similarity between woven designs (especially of basketry) and the early repertoire of design used in pottery. Weaving again appears as a prominent element in a second group of svastikas--at Troy. The vast majority of the symbols found there occur on the weaving implement called a spindle-whorl. Very probably they were made by the women who used them to spin the thread for the clothing of the Trojans.⁵⁶ The diversity of shape and design of these objects supports that conclusion.⁵⁷ As such, the designs and symbols which appear on them are among the earliest art forms which can be specifically attributed to women. Appendix 5 illustrates the major motifs appearing on the whorls: rotation, trees, quartering, animals, svastikas, and some marks which defy description, even while implying meaning.⁵⁸

These are the elements of the complex of symbols discussed in chapter 3. Particularly interesting in this respect are the tree-symbols seen in section B. They are nearly always drawn as if their roots were in the shaft hole

of the whorl while their branches extend to the outer edge. Conversely the animals (section D) are drawn with their feet toward the outer edge, as if that were ground level. Another interesting inconsistency can be seen in section A. These whorls are inscribed with patterns suggesting rotation. But depending on the whorl, sometimes to the right and sometimes to the left. It may well be that the direction was determined according to whether the operator was right- or left-handed.

Regardless of the orientation of the designs on the objects, the whorls themselves as well as the spindle are a perfect representation of the axis mundi which extends upwards through the earth to heaven and the pole star; and often down into the nether regions. When the spindle is put into the shaft hole of the whorl and then spun, it collects the thread from the top of the spindle and gathers it on the whorl. With a little imagination added, the image one gets is that of a woman sitting, and daily gathering skeins of finely-spun wool. This image is still present in our own culture in the form of myth and fairy tale.

Plato, in the myth of Er from the Republic, describes exactly this image. The goddess Necessity holds the earth in her lap and its axis is described as⁵⁹

a Straight Light extending from above through the whole Heaven and Earth, as it were a pillar, for colour most like unto the rainbow, but brighter and purer... this light is that which bindeth the Heavens

together;...and from the ends extendeth the Spindle of Necessity, which causeth all heavenly revolutions...

Nearby are her daughters, the Fates Lachesis, Clotho, and Atropos.⁶⁰

they chant to the melody of the Sirens; Lachesis chanteth of the things that have been, and Clotho of the things that are, and Atropos of the things that shall be;

A similar picture is drawn of the Norns, those enigmatic and dark women who show up, the day after creation, unannounced to take up their residence at the foot of Yggdrasil (the World-Tree of the Norse myths). Like the Greek Fates, the three Norns spin out, measure, and cut the threads of human destiny. Hollander describes them and their abode:⁶¹

An ash I know, hight called Yggdrasil, the mighty tree moist with dews white; thence come the floods that fall adown; evergreen, o'ertops Urth's well this tree. Thence wise maidens three betake them-- under spreading boughs their bower stands--Urth is one hight, the other Verthandi, Skuld the third; they scores did cut, they laws did make, they lives did choose: for the children of men they marked their fates.

Bauschatz describes this Fate as a force, noting:⁶²

The cultic representations of this force are chthonic in origin and from the beginning are associated with death in inscriptions and hymns. They appear early as 'spinners of man's lot,' and are often represented as being present at man's birth.

In the construction of the names of the Norns the same role of time is retained. Bauschatz traces all of their names to the verb verda, from which the German word to be (werden)

is derived. It in turn is derived from the Proto-Indo-European root *uert denoting motion common to spinning, turning, and rotating. He adds,⁶³

It should be pointed out additionally that the motion of 'turning' or 'changing position' found in *uert implies revolution about an axis.

In Sanskrit the same connection between spinning (or rotating) and existence is found in the word vṛt.⁶⁴ Its meaning is given by Apte, and includes: To be, exist, remain, abide, stay, to happen, occur, come to pass, to proceed in a regular course, to turn, roll on, revolve. The words involved in this concept contain the same innate paradox found in the morphological significance of the svastika: fixity and movement. Furthermore, both vṛt and asti have identical meanings to that of the Fates: existence, and axial movement.

Also derived from vṛt is Vṛtra, the heavenly dragon whose coils contained the waters of fertility, and who was slain by Indra (the Rain-god). His name is also said to mean darkness and wheel. The image involved here is of the rotating night sky proceeding in its regular course around the abiding centre--the Pole star. A series of verses from the RgVeda confirms this notion and brings back into the discussion its central element--weaving.

The first verse relates the verb "web (tantra = book) of worship" to the warp and woof of two weavers (interpreted

as night and day):⁶⁵

Good work for us, the Glorious Night and Morn,
like female weavers, waxen from aforetime,
yielders of rich milk interweave in concert
the long-extended thread, the web of worship.

Again in book 10, the sacrifice is described as "threads":⁶⁶

The sacrifice is drawn out with threads
on every side stretched by a hundred
sacred ministers and one.

But in book 1, a new image appears:⁶⁷

For up above the yearling calf, the sages
to form a web, their own seven threads have woven.

The Sages, or Rishis, have their abode in the Great Bear,
the most prominent of all the circumpolar constellations.⁶⁸

Mighty in mind and power is Visvakarman,
Maker, Disposer, and most lofty Presence.
Their offspring joy in rich juices where
they value only One, beyond the Seven Rishis.

In the note to this stanza, Griffith explains the reference to the Seven Rishis as being the "Constellation Ursa Major, the seven stars of which are the Great Rishis."⁶⁹ A passage from the AtharvaVeda (also RgVeda 1.164) is important in this regard as it describes the cosmology of the Vedas in terms very much like those Rybakov uses to describe Tripolyan cosmology. It also further elaborates upon the connection between the Sages and the Big Dipper.

In this beautiful and elaborate hymn, three Hotars are described: the second is the ancient voracious lightning (that is, the priest of the middle air); the third priest is the altar where the sacrifice takes place. According to

Rybakov's scheme, the 1st priest should be beyond the sky in upper heaven. According to our contention that priest should be the Pole star (around whom the Big Dipper revolves).⁷⁰

The second brother of this lovely Hotar, hoary with eld, is the voracious Lightning.
The third is he whose back is balmed with butter.
Here, have I seen the King with seven male children.

The seven make the one-wheeled chariot ready:
bearing seven names the single Courser draws it.
The wheel, three-naved, is sound and undecaying:
thereon these worlds of life are all dependent.

All of these images seem to come together in a story from the Han dynasty of China.⁷¹ An illustration of the story can be seen on two stone-engraved slabs from the ceiling of a shrine. On these two slabs are depicted the Weaving Lady, beside her is a circle with a bird head-down in it, and the third element is a snake. The second slab is a "connect the dots" drawing of the Big Dipper. Beside it is another circle (with a frog or a turtle in it). The story connected with the drawings says that⁷²

the Weaving Lady was the daughter of the Sun-god, or T'ai I--who resided on the pole star, and who married her to the Herdboy (a near-by constellation). After the wedding she neglected her work, and for this reason her father separated the couple allowing them to unite only once a year on the seventh day of the seventh month. On this day the Magpies formed a bridge over which she would cross the Milky Way (supposed to be a wild river) to join her husband.

From these associations it is possible to suggest that the markings on the spindle whorls from Troy are re-

lated to the sky and the stars that fill it. For example section A shows rotation around the axis (the hole or the spindle); section B gives us the tree which is so often the symbol of the axis mundi (Appendix 4 C and D, figures 25-45);⁷³ section C shows various schemes of quartering associated with the distribution of space around the sacred centre; section D shows animals arranged around the centre. 1879⁷⁴ shows a very interesting tableau. On one side of the shaft hole is a group of animals. On the opposite side, a series of svastika-like figures. Between the two groups runs a crooked double line which could represent the Milky Way. Section E shows svastikas, possibly in rotation around the pole. The last two figures are not spindle whorls, but clay balls of unknown purpose. Both contain svastikas. In one (1999) the ball is divided into 8 sections, one of which contains a svastika. This may mark the zone in which Troy was located (a device similar to the Thracian coin and the Indian coin). On the other ball a topmost circle contains a mark that may be either a sun or a simple symbol of rotation. By our morphological definition (see chapter 1), it is a svastika.

A final note about spindle whorls and their relationship to the centre and its symbols suggests that the shape and design of these objects may be more than accidentally related to ancient cosmology. E. A. S. Butterworth's study,

The Tree at the Navel of the Earth, is an excellent collection of motifs and symbols relating to the concept of the axis mundi in ancient religious beliefs. One of the symbols he deals with is the ompholos. The ompholos (the navel) is a cultic object well-known in the Mediterranean area. He describes it as follows:⁷⁵

The ompholos varies a great deal in both shape and size. Its typical shape is approximately that of the old-fashioned domed bee-hive, but it may be much lower and flatter in outline...It may be represented in vase painting as even egg-shaped. It may stand flat upon the ground (partly buried in it), or on a base,

Butterworth goes on to say that it may be one- to four-feet in size, plain or decorated, and associated with grave-mounds or tombs. He quotes another author (W. H. Roscher) who pointed out that the ompholos should describe a hole, a shaft, or a dépression, rather than a projection or a conical shape.⁷⁶

The above description of this object fits perfectly (except for its size) the spindle whorls of Troy! Seen from above, as the spinner would see them, whorls are circular in shape and the shaft-hole at the centre forms another circle in the centre. From this view, spindle whorls are exact replicas of the symbolic design which Butterworth calls the ompholos-symbol.⁷⁷

IV. Summary

Graphic representation on prehistoric materials provides information on the world-view of the peoples who produced them. Because these signs and symbols are not explained by accompanying linguistic information they need to be deciphered. Modern religious practice, texts, folklore and customs, myth and history provide the keys for translating the symbols into concepts. Changes in the symbolic repertoire reflect the changes in conceptualization which occur as a result of historical circumstances.

The object of this analysis of prehistoric art is to determine the relationship of the svastika to early conceptions of space. Particular emphasis is placed on the role of the centre in its relationship to prehistoric religious practice.

One of the most common and early divisions of space is horizontal quatering. Its centre is the altar, the navel, a political division, a mountain, a tree, and the Pole star. The svastika is commonly found in the middle of compositions which reflect this spacial orientation. Light, water, and fertility are associated with it.

A second division of space is vertical. This scheme usually represents the cosmos as situated on a series of upward-layered planes. The number of planes is frequently

three, but sometimes four. At its centre is one of the surrogates of the axis mundi. Communication between the planes is possible only through this centre.

The highest level usually contains a water symbol or ideogram. The lowest level is the realm of death. In early ware it is frequently empty. In the Rhodian ware dormant lotus-plants float on water. The middle space(s) corresponds to the earthly plane and the lower atmosphere. Most often sun-symbols and other atmospheric symbols (moon, stars, birds, clouds) are pictured along with animals and vegetable-symbols.

In the early Indo-European pottery spirals are present in the middle plane(s). In the later Indo-European Rhodian pottery the svastika has replaced the spiral in the same area. In the same period (3000-600 B.C.) the fertility ideogram has become fused with the lotus. Both of these cases are examples of the surrogation of symbols. The amuletic function of these symbols of fertility remained unchanged as did their role as symbols of the sacred centre of vertical (axis mundi) and the horizontal (altar) space.

Trojan svastikas are of a completely different style. They are incised instead of painted. Nevertheless, the symbols associated with the svastika are basically the same, even if their relationship to spacial concepts is less certain. The earliest examples occur on the rims of bowls, and

later examples are found on the navels of "owl-faced" vases. These latter objects should rightly be called "fertility" vessels in respect of their navel, breasts, and uplifted arms. The most common provenience of svastikas are spindle-whorls.

The major significance of the Trojan materials resides in the resemblance which spindle-whorls bear to the image of the axis mundi and to the omphalos-symbol. If they are so intended, that would explain the configuration of symbols which occur on them distributed around the hole (spindle). The decorated upper-half would correspond to all of the levels above ground level. Some of the inscriptions may be intended to represent atmospheric and heavenly objects. At other times, hunting and ritual scenes predominate, usually involving animals. Frequently whorls are inscribed with rotational or quartering patterns indicating an association with horizontal space.

The Cretan, Chinese, and Indian evidence seems to suggest that the lotus, the labyrinth, and the svastika stood for the sacred space of initiation, that these symbols were surrogates of each other in that respect. In the Trojan and Rhodian material the svastika, the lozenge, and the lotus represent fertility. In Samarran and Mimbres ware, it is associated with death, water, and water animals. Death, fertility, and initiation are all associated with

water through ritual and cultic acts which take place by definition at the centre.

In Samarran and Mimbres ware, the svastika appears to be a pattern derived from weaving and basketry. In Troy it appears mainly on objects associated with women and weaving. Most prehistoric examples of svastikas appear on artifacts associated with women, and were meaningful to them.

The configuration of ideas associated with weaving in mythology, religious texts, and in the physical structure of the implements are: darkness, existence, creation, rotation, woman, the svastika, the four directions, and the tree.

All of these ideas are found associated with the ritual centre in prehistoric religion which extends from the altar to the Pole star. The circumambulation of the heavens about the axis provides the basic pattern which is reproduced in ritual circumambulation, weaving, and in the morphology of the svastika.

As such, it serves as a pictograph suitable for symbolizing all of those levels of religious behavior.

NOTES

¹Linguistic paleontology attempts to reconstruct prehistoric culture from words. Somewhat in the manner of the archeologist, he excavates the language.

Winfred P. Lehman, "Linguistic Structure as Diacritic Evidence on Proto-Culture," Indo-European, eds. Cardona, Hoenigswald, and Senn, pp. 1-10. Lehmann notes: "that language be used only as a diacritic, not as a primary source for reconstruction of early culture." (page 2)

²K. P. Schick, English-Hungarian: Hungarian-English Dictionary, s.v. "Svastika."

³Mackenzie, Migration, pp. 95-96.

⁴Ibid.

⁵Rybakov, "Cosmogony and Mythology," p. 17.

⁶Ibid., p. 18.

⁷Ibid.

⁸Johannes Maringer, "Grave and Water in Prehistoric Europe," Journal of Indo-European Studies 3 (1975): 121-145.

⁹Ibid., pp. 123-124.

¹⁰It may just as well be true that the later sources have associated death and water from the fact that the megaliths are there. The megalithic builders may have had quite another reason. When using diachronic information to assess archaeological material discretion is the better part of scholarship.

¹¹Sankar Sen Gupta, "A Study of Ganesha: A Distinct Member of the Durga Family in Bengal," Folklore (Cacutta) 14 (1973): 323-337.

¹²Ibid., p. 324. Dr. Roy Amore reports encountering a similar practice on a recent visit to Sri Lanka. There, Hindus (and Buddhists) include a Ganesha image in shrines under Bo trees.

¹³Ibid.

¹⁴Fairservis, Roots of Ancient India, p. 277 (figure 23).

¹⁵See the "Proto-Siva" seal, ibid., p. 276 (figure 17).

¹⁶Emily Townsend Vermeule, "Mythology in Mycenaean Art," Classical Journal 54: 96-107.

¹⁷Ibid., p. 99.

¹⁸Ibid., p. 100. See also, Sp. Marinatos, "On the Track of Folklore Elements in Bronze Age Art and Literature," International Congress for Folk-Narrative Research in Athens 4: 262-273.

¹⁹Compare Rybakov's description (rather than the vases) to any of the vases of the Greek Geometric period (1st millennium). Figure 20 is an example of this later style.

²⁰Rybakov, "Cosmogony and Mythology."

²¹Mackenzie, Migration, pp. 94-96.

²²David V. Villaseñor, Tapestries in Sand: The Spirit of Indian Sandpainting, ed. Vinson Brown (Healdsburg, Calif.: Naturograph, n.d.), pp. 15, 35.

²³Frederick Webb Hodge, ed., Handbook of American Indians North of Mexico, 2 vols. (New York: Pageant Books, 1960), 1: 366-367.

²⁴John Perry, Lord of the Four Quarters; Myths of the Royal Father, Patterns of Myth series, gen. ed. Alan W. Watts (New York: George Braziller, 1966).

²⁵Rybakov, "Cosmogony and Mythology," p. 22.

²⁶Zenia Nuttall, The Fundamental Principles of New and Old World Civilization: A Comparative Research Based on a Study of Ancient Mexican Religious, Sociological, and Calendrical Systems, Archaeological and Ethnological Papers of the Peabody Museum, Harvard University, no. 2 (Cambridge: n.p., 1900; reprint ed., New York: Kraus Reprint Co., 1970).

²⁷Ibid., p. 3. On page 14, Nuttall writes:
 "In a flash of mental vision I perceived a quadrupled image of the entire constellation standing out in scintillating brilliancy from the intense darkness of the wintry sky. I saw that it bore the semblance of a symmetrical swastika of giant proportions..."

²⁸Mackenzie, Migrations, p. 95.

²⁹Ibid., p. 104. Compare this statement with Eliade's (Patterns, p. 128): "Even the oldest phases of primitive cultures display both a beginning of the transfer of the sky-god's attributes to the sun god and an amalgamation of the Supreme Being with the sun god."

³⁰Rybakov, "Cosmogony and Mythology." The vase in figure 20 is from Rhodes.

³¹Ibid., p. 26.

³²Ibid.

³³Ibid., p. 17. Rybakov notes:
 "The territory between the Carpathians and the Dnieper, inhabited at that time by Tripolyan tribes, is regarded by modern linguists as the northeastern portion of the Indo-European "original homeland" of the Neolithic epoch."

Gimbutas, "Proto-Indo-European Culture," p. 178. The Greek Geometric Ware is called Indo-European because the people spoke an I-E language. The question of whether they were I-E culturally is beyond the scope of this paper. But, the retention of so many symbolic elements of Tripolyan design seems to suggest that they were.

³⁴Goodyear, Grammar.

³⁵Rybakov, "Cosmogony and Mythology," pp. 20, 21, 22.

³⁶Ibid., p. 21.

³⁷A. M. T. Jackson, Folk Lore Notes; Gujarat, comp. R. E. Enthoven (Mazgaon, Bombay: British India Press, 1914), p. 153.

³⁸The lotus-throne is a common iconographic element. It is seen in a great deal of Indian statuary. See note 39.

³⁹Danielou, Hindu Polytheism, p. 237. Brahma is depicted in association with both the lotus and the Goose. It is interesting to compare that association with the upper level of Appendix 7, figure 20.

⁴⁰Hermann Jacobi, Jaina Sutras; The Akaranga Sutra, new ed., The Sacred Books of the East series, no. 22 (Delhi: Motilal Banarsidass, 1964). The liberated Jiva will rise to the summit of Loka and there will remain at the pinnacle.

⁴¹Eliade, Patterns, pp. 100, 106.
Butterworth, The Tree, pp. 69-72, where the author discusses the evidence for calling An, the Sumerian god, a Pole star diety.

⁴²Rybakov, "Cosmogony and Mythology," p. 27.

⁴³Ibid., pp. 27-29. See also Eliade, Patterns, pp. 188-215. The waters are always creative.

⁴⁴Goodyear, Grammar.

⁴⁵Raymond Christinger, "The Hidden Significance of the Cretan Labyrinth," History of Religion (1975), pp. 183-191.

⁴⁶Mark P. O. Morford and Robert J. Lenardon, Classical Mythology (New York: David McKay Co., 1974), pp. 363-372.

⁴⁷Eliade, Patterns, pp. 288, 381.

⁴⁸Arthur Bernard Cook, Zeus: A Study in Ancient Religion, 2 vols. (n.p.: Biblo & Tannen, 1964) 2: 475-476.
Arthur Evans, The Palace of Minos Knossos, 2 vols. (n.p.: Biblo & Tannen, 1964) 1: 357-358, 515; and 2: 492.

W. H. D. Rouse, "The Double Ax and the Labyrinth," The Journal of Hellenic Studies 21 (1901): 268-274.

Arthur J. Evans, "The Palace of Knossos," Annual of the British School at Athens 9 (1902-03): 1-154. On page 89 Evans writes: "At Eryx the Swastika symbol alternates in the same position with a star, that very universal mark of divinity." This view accords well with that of Cook, who says in Zeus, p. 476, "It would seem that the Attic tradition points back to a time when the labyrinth was depicted not as a palace, but as a meander, or as a swastika pattern."

⁴⁹Evans, "The Palace," p. 89.

⁵⁰Wilson, "The Swastika," p. 772.

⁵¹In China the Pole star cult which can be clearly traced back to the time of early Taoism remains still very strong. The Taoists considered the Big Dipper as the Dispenser of Fate. Some of the sources for this material are:

Christenger, "The Hidden Significance."

Schuyler Camman, "The Magic Square of Three in Chinese Religion and Philosophy," History of Religion (1961): 37-80.

Joseph Needham, Science and Civilization in China, 5 vols., collab. Wang Lin (Cambridge: University Press, 1959), esp. vols. 3-4.

A. Bulling, The Meaning of China's Most Ancient Art: An Interpretation of Pottery Designs from Kansu (Ma Ch'ang and Pan-Shan) and their Development in the Shang, Chou and Han Periods (Leiden: E. J. Brill, 1952), pp. 43-44, et passim.

Michael Sasso, Taoism and the Rite of Cosmic Renewal (n.p.: Washington State University Press, 1972).

Sasso, "Orthodoxy and Heterodoxy in Taoist Ritual," Religion and Ritual in Chinese Society, ed. Arthur P. Wolf (Stanford: Stanford University Press, 1972), pp. 325-336.

Loewenstein, "Swastika."

⁵²Camman, "The Magic Square," pp. 60-69.

⁵³Ibid., p. 63. See also Perry's book for parallels.

⁵⁴Ibid., p. 58.

⁵⁵Christenger, "The Hidden Significance," p. 186.

⁵⁶This cannot be proved since only witnesses could testify to who made this whorl or who made that one, but the

diversity of form and design indicates that they were personal objects rather than "factory-made." See also R. J. Forbes, Studies in Ancient Technology, 9 vols. (Leiden: E. J. Brill, 1955-) 4: 177.

⁵⁷See Appendix 5.

⁵⁸These may be Proto-script. . See Winn and Schmidt.

⁵⁹J. A. Stewart, The Myths of Plato, Centaur Classics Series, gen. ed. J. M. Cohen (London: Centaur Press, 1960), pp. 149-150.

⁶⁰Ibid., p. 161.

⁶¹Quoted in Paul Bauschatz, "Urth's Well," The Journal of Indo-European Studies 3 (1975): 53-68, on page 54.

⁶²Ibid., p. 62.

⁶³Ibid., p. 66.

⁶⁴Apte, Sanskrit-English Dictionary, s.v. "vr̥t," and "vr̥tra."

⁶⁵Griffith, R̥gVeda, 2.3.6.

⁶⁶Ibid., 10. 130. 1-2.

⁶⁷Ibid., 1. 164. 5.

⁶⁸Ibid., 10. 82. 2.

⁶⁹Ibid.

⁷⁰Ibid., 9. 9. 1-2.

⁷¹Bulling, China's Ancient Art, pp. 43-44.
Edward H. Schafer, "The Sky River," Journal of the American Oriental Society 94 (1974): 401-407.

⁷²Bulling, China's Ancient Art, pp. 43-44.

⁷³Butterworth, The Tree,

⁷⁴Schliemann's figure-numbers have been retained for ease in checking the illustrations against his text.

⁷⁵Butterworth, The Tree, p. 26 :

⁷⁶Ibid. Kurgans (i.e., grave-mounds) also appear similar to this description of the ompholos.

⁷⁷Ibid., pp. 37-47. The symbols repeatedly connected with Butterworth's ompholos-sign are usually the ones connected with the svastika and often appear on spindle-whorls as well--four-pointed stars, bucranium, serpents, etc.

Goodyear, Grammar, notes that the sacred "cone" is a lotus bud. It commonly occurs as a capital on tomb-columns in Cyprus (pages 175-181).

CONCLUSION

I have traced the roots of the svastika from its earliest use in northern Mesopotamia (5500 B.C.) to the borders of northern India in the 3rd millenium B.C. The early history of the symbol clearly refutes any claim to its Aryan origin.

In approximately 4000 B.C., the svastika appeared independently in southcentral Europe among the Danubians. Its use with a proto-script in that culture is similar to the manner in which the svastika was used by the ancient Indians who inhabited the extensive Indus Valley civilization. The two are similar also in the style of use. Etched or incised symbolism was more common in the European branch than it was in the Samarran (Mesopotamian). In the latter, painted ware predominated.

Nevertheless, the two branches of the svastika's pattern of distribution seem to come together in the sub-continent of India and Pakistan. In that climate the symbol took root and flourished from the 3rd millenium until today, with the exception of the Vedic period (1100-600 B.C.). Not until the 7th century B.C. did the svastika arise again from the obscurity thrust upon it by Aryan rule. The svastika again became an important religious symbol to the Buddhists,

Jainists, and Hindus after the Vedic decline. Today it remains a symbol of prosperity and auspicious beginnings. It is the emblem of Ganesha, the elephant-headed god, and is drawn before undertaking anything of importance.

But its exact meaning remains a mystery. Many interpreters have sought to decipher it, and all have unmasked a facet of the svastika, but none has uncovered its whole meaning. All have made the same mistake. They sought to study the symbol without first reconstructing its symbolic environment. In other words it was studied out of context and without reference to the one clue which we truly possess as to its meaning: those symbols which accompany it.

On the painted ware of Samarra, on that of the Mimbres pottery, on the stamp seals of the Indus Valley, and the spindle whorls of Troy, the same configuration of symbols appeared with svastika. These symbols varied only to the extent that one might expect from cultural differences. Otherwise they remained the same: tree, animal, and woman or weaving. Usually the svastika occurred in the centre of the composition, but even when it didn't it still maintained its relationship to the axis mundi. Because of its universal capability of marking the centre, it became a generic symbol of sacred space.

At other times, the svastika did not appear in the configuration of symbols. Cultures where it is absent are

Egypt and the Levant, and in the region of the Indo-European Urheimat before 4000 BC. In fact it is possible to say directly that the svastika by reason of its distribution is not originally an Indo-European symbol. Its roots lie much more deeply implanted in the soil of the neolithic Near East.

But with the spread of the Indo-Europeans at the dawn of history (3rd-2nd millenia BC) the indigenous use of the svastika in cult was overlaid with a thick and glossy veneer of sun-worship. The sun usurped the throne of the elder god, and the svastika was absorbed into the religious practice of the Indo-Europeans.

According to Eliade, and to the remnants of literary evidence, earlier worship was centred on the sky-god. That is here understood to mean the movements of the stars around the high pinnacle of heaven--the Pole star. As such, the conceptual roots of the svastika are laid bare. The morphological significance of the svastika is exactly that of Polar rotation. It represents both fixity and motion. At the personal level, the symbol represents devotion to the centre; at the ritual level, it mimics heavenly rotation in the act of circumambulation.

Among the peoples that use the svastika as a symbol of the centre, it designates those things, Gods, images, utensils which are associated with the cultus. But among those

who do not use the svastika another symbol must be found which fulfills that role in the religious system. The early Indo-Europeans used the spiral and the solar (or rayed) disk. The Egyptians expressed the concept through the lotus symbol and the winged disk. The Hebrews had a tree, and often a mountain.

One need only look with fresh eyes on the svastika as it was used in Nazi Germany by Hitler to see that little has changed in the way that the symbol strikes the mind of man. Even for Hitler it was a positive sign. He called it the symbol of the victory of Aryan man. It emerged as the central symbol of the German (neo-Pagan) revival.

Today, in the western world, the symbol is attached not only to Nazism, but to Hitler, as well. But to characterize it as a symbol of Hitler is obviously not accurate, just as it is wrong to label it as a symbol of the sun. Nor is it right to allow the Nazis or anyone else to lay claim to the symbol. It belongs to no one. The svastika belongs to the world.

The historically consistent use of the svastika throughout time and space suggests very strongly that man does not change. Only his tools evolve. The burin gives way to the axe and the knife. Bone and stone melt before the onslaught of copper, and bronze, and iron. But wars are still fought. Songs are still sung of hate and love.

The social institutions still seek to formulate answers to personal questions just as they did 10000 years ago. Over many centuries the institutions change, some slowly and others more quickly, but the human questions remain much the same.

Symbols, like the svastika, float in and out of use but their nature is fixed by the way in which the very form itself dictates of our perception; itself, altered only to the degree that man differs from man. To the degree that humans do not differ--that is the degree of similarity in perception and action. All humans experience birth--before language. All await death--a word for which there is no experience. What do we do with these words beyond language, and these expectations of experience? They are absolutely identical realities which all must suffer. And all experience hunger or desire, which was the catalyst of creation according to the following Vedic hymn:¹

Darkness there was: at first concealed in Darkness;
This-All was undifferentiated Chaos, void and formless.

By the great power of Warmth (tapas) was born That-One.
Thereafter, rose Desire, in the Beginning, Desire,
The Primal Seed (Bindu) and germ of Spirit...

Who knows whence It first came into Being?

Who knows? But all have experienced it, before there were words to suck for knowledge. There, before the veil was drawn, before there was warm milk to quench the hunger and still the soul. There, there was only--emptiness and

grasping.

These experiences are common to us all, and some others as well. For instance, the sun, and fear, and Death. All of these have at least one thing in common. We experience them before we know what they are, or what they mean. We develop a schema of meaning, a pattern of meaning that helps us to know, to understand--even the puzzle of our own puzzlement.

It is like trying to play leap-frog with yourself. Knowledge cannot overcome ignorance, nor can language ever fully express experience. Certain things, those common human things, were settled early and given a name, like one, two, three, four, five, or like ma, and am. Other things, experiences, are still largely unknown, ineffable, inexpressible, in words. But some have evolved symbols as a meta-language, like the svastika.

These symbols are not the same in everyone. They vary as I vary from you. But the thing they represent, the experience they were formed to express, does not vary. It is constant. It is what I call a role, experience seeking language--seeking a name. Not everyone experiences every role. Some have only heard of that experience. They have a schema for which they have no experience, as I, for instance, have no experience of God, or Death, except at second-hand. These are names which seek experience.

Symbols are the intermediaries of the two. Like Hermes they bear cryptic messages to man and among the Gods. Now, the meaning of these things, these symbols, these cryptic messages, is the thing itself, the symbol. One equals One. Svastika is Svastika.

卐 is Ganesa, 卐 is Prosperity, 卐 is Odin. 卐 is the Labyrinth wherein the Minotaur awaits to slay or be slain.

卐 is an experience which is partially submerged, withdrawn, like the dormant lotus awaiting creation, manifestation, birth amid the warmth and the waters, on the Navel of the Sleeping God. Below it, at the bottom of it All is the Serpent coiled within itself, devouring itself. And on its head is the symbol, present in the beginning, repeated at every new beginning--the first invocation--卐. It is devotion; the never-ending procession of the Celestial Hosts around the High Throne of the Most Holy Ancient One. Its centre is the Polestar, the stable point, above the Brother whose "back is balmed with butter," above the Lightning, "hoary with eld," in the Highest Nave is the still point:²

At the still point of the turning world. Neither flesh nor fleshless; Neither from nor towards; at the still point, there the dance is, But neither arrest nor movement. And do not call it fixity, Where past and future are gathered. Neither movement from nor towards, Neither ascent nor decline. Except for the point, the still point, There would be no dance, and there is only the dance.

But the rhythm of the song, its melody and harmony, is determined by the Seven Sons of Aditi. They set the tune in

motion.³ Among the Greeks, they say, the Sirens sit on Seven rings upon the Spindle of Necessity. Below them are the eight circles of the whorl, turned by the Music of the Spheres. Each is a planet. The seventh is the sun, the eighth, the moon. Upon those ancient whorls is the svastika. In the lists of Jainist Heroes, the eighth has the sign of the half-moon, while the seventh "is marked with the Svastika, i.e., the sun."⁴

Close contemporaries are Plato and Mahāvīra. Late is the myth and the list in comparison with the Vedas, even those late hymns in which the presence of the sky-god has not yet faded from the glory of the sun. By the time of the 6th century the solar cult had fully established its gods in the zenith in padmāsana, or svastikāsana.

The sun now wears that symbol of the older faith, like a svastika emblazoned on a circle, around which march the endless legions of Darkness:⁵

There is no lunacy people under the domination of an archetype will not fall prey to. If thirty years ago anyone had dared to predict that our psychological development was tending towards a revival of the medieval persecutions of the Jews, that Europe would again tremble before the Roman forces and the tramp of legions, that people would once more give the Roman salute, as two thousand years ago, and that instead of the Christian Cross an archaic svastika would lure onwards millions of warriors ready for death--why that man would have been hooted at as a mystical fool. And Today?

And Tomorrow?

I have yet another answer to Muller's question:⁶

"Why the sign should have had an auspicious meaning, and why in Sanskrit it should have been called Svastika."

Because, in the Beginning, before even the Word was formed, when the Lake of Mead, the Well of Mead, in Vishnu's highest footstep, was churned by the serpent Shesha, or by the Throes of Vr̥tra; then the Ambrosial Stream was loosed and fell on its milky way through the abode of the Seven, the One Dipper made Four, to earth, bringing Prosperity to us all.?

From Her descend in streams the seas of water;
Thereby the world's four regions have their Being.
Thence flows the Imperishable Flood,
and Thence, the Universe hath Life.

O Noblest Svasti, with abundant riches,
Who comes to what is good by distant pathways,--
May you, at home and far-away, protect us,
and dwell with us under the Gods' protection.

NOTES

- ¹Griffith, RgVeda, 10. 129. 3-4, 6.
- ²T. S. Elliot, quoted by Huston Smith, Forgotten Truth; The Primordial Tradition (New York: Harper Colophon Books, 1977), p. 33.
- ³But even the Rishi's operate by a Higher Law:
"Seven germs unripened yet are heaven's prolific seed: their functions they maintain by Vishnu's ordinance." Griffith, RgVeda, 1. 164. 36.
- ⁴Wilson, "The Swastika," p. 773.
- ⁵The legions of Darkness are the Asuras, the Dévas, and the Storm Troopers of Nazi Germany.
Jung, The Collected Works, 9: 48.
- ⁶Wilson, "The Swastika," p. 773.
- ⁷Griffith, RgVeda, 10. 63. 16.

The Morphological Spectrum

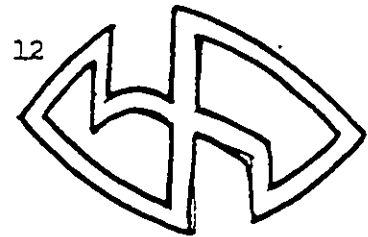
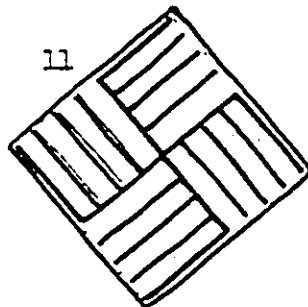
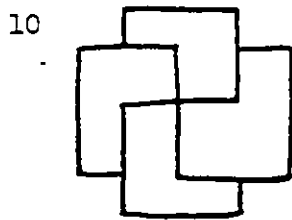
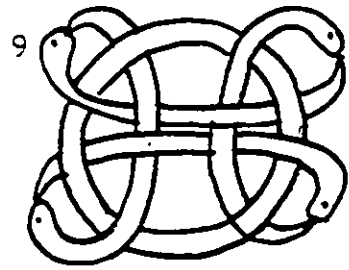
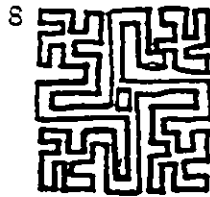
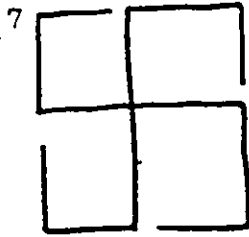
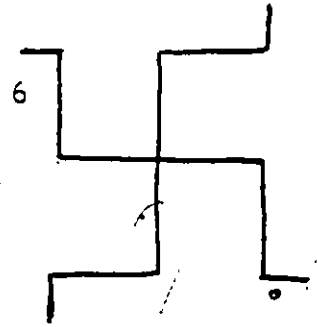
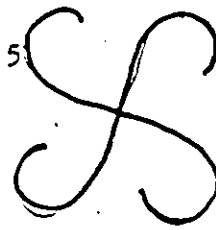
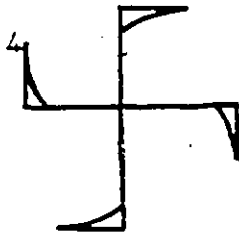
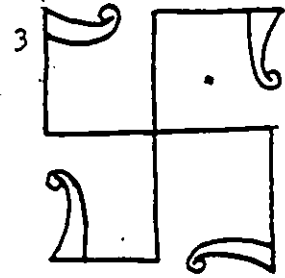
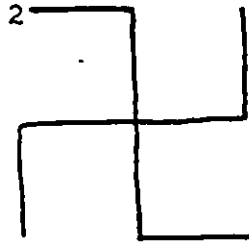
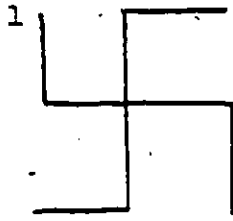

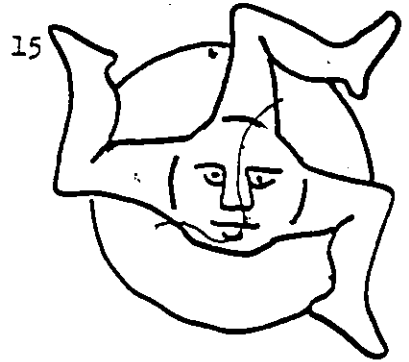
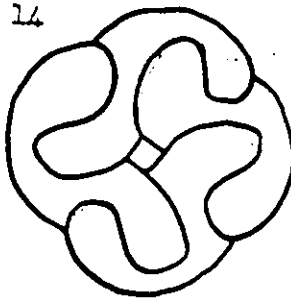
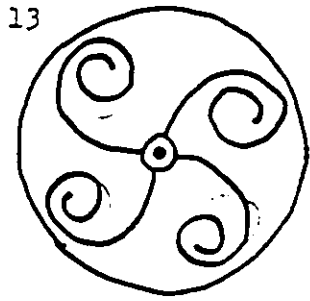

16



17

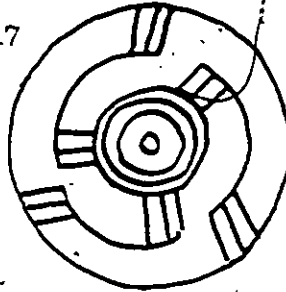

18

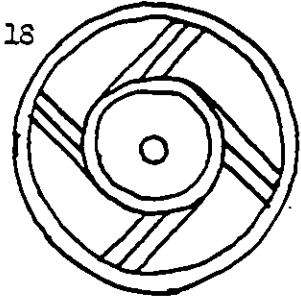

19

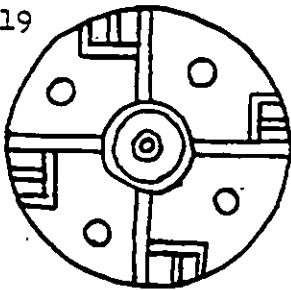

20

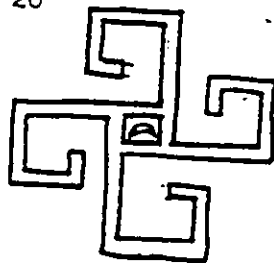

21

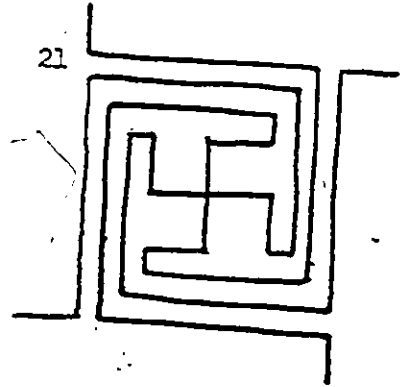

22

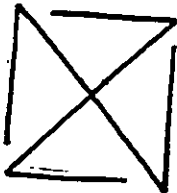

23

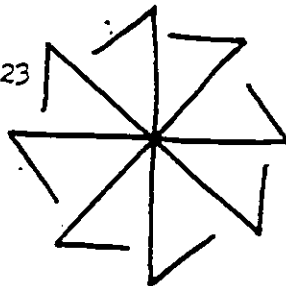

24

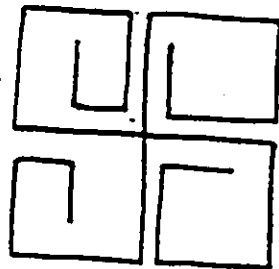

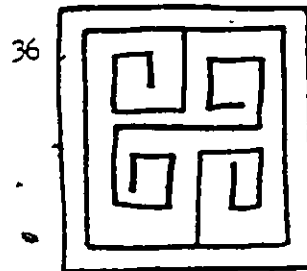
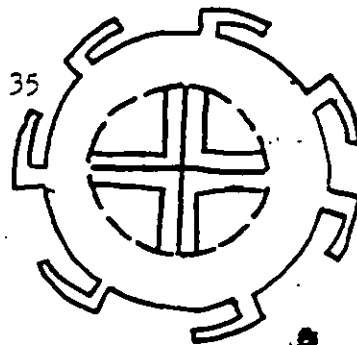
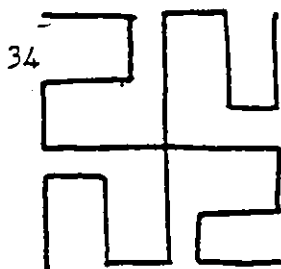
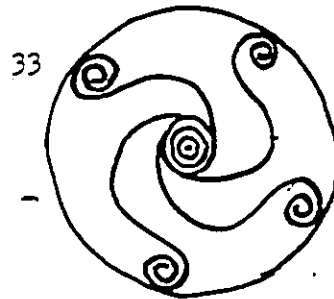
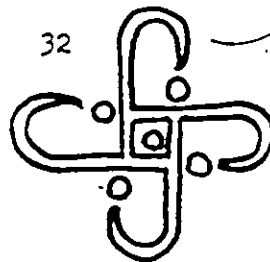
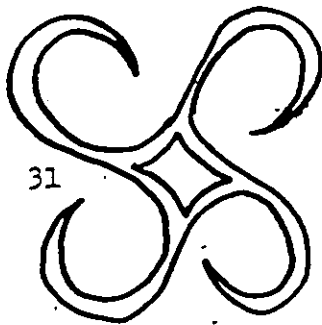
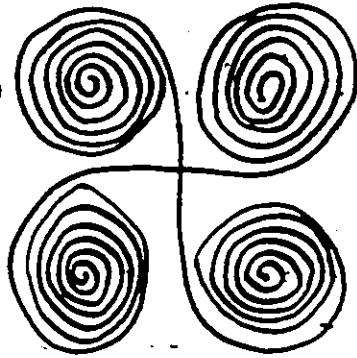
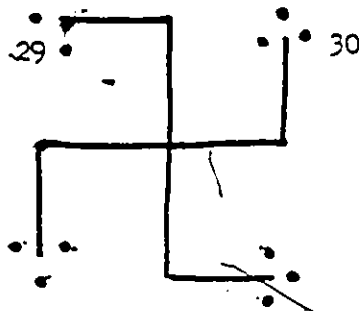
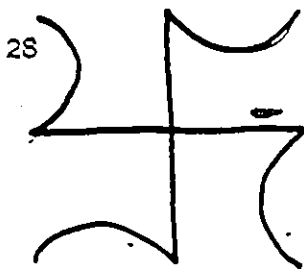
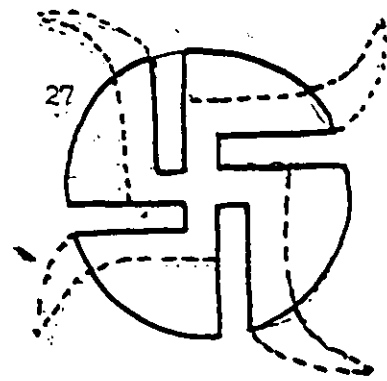
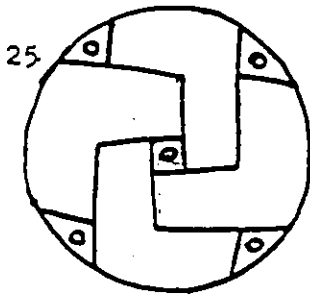

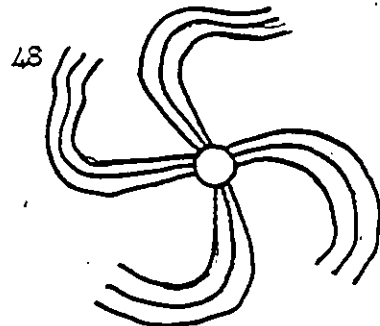
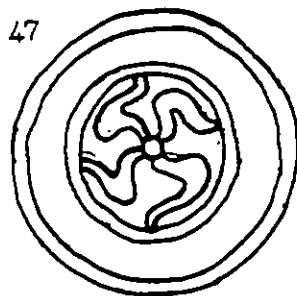
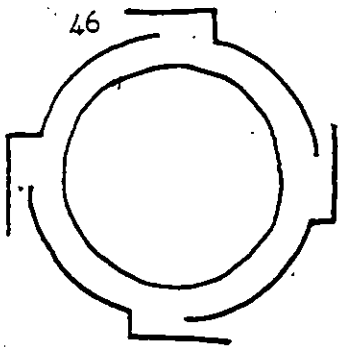
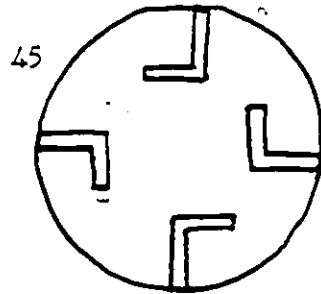
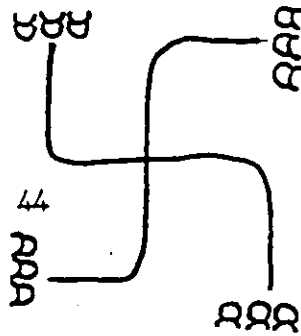
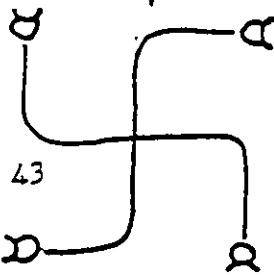
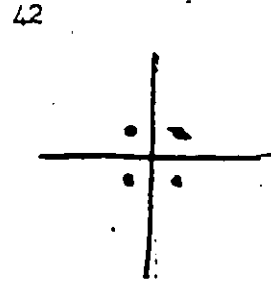
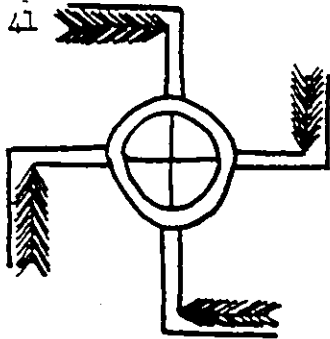
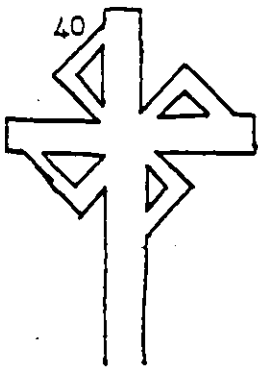
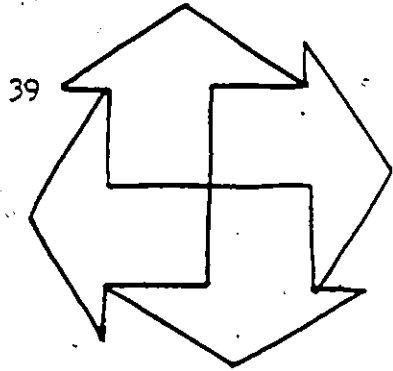
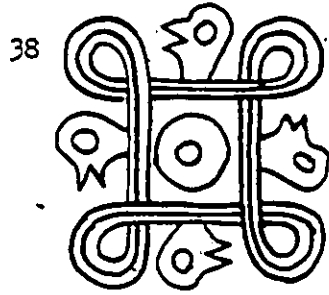
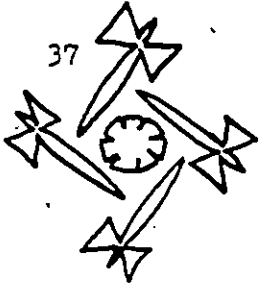

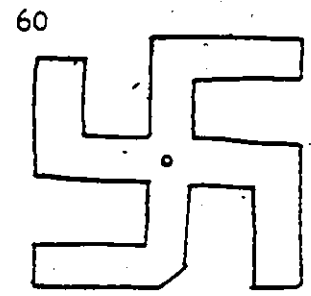
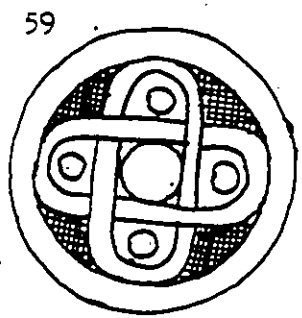
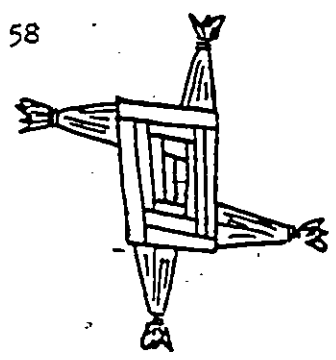
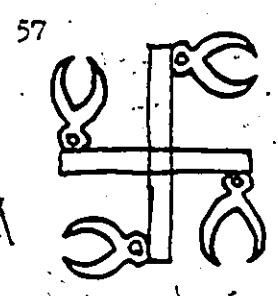
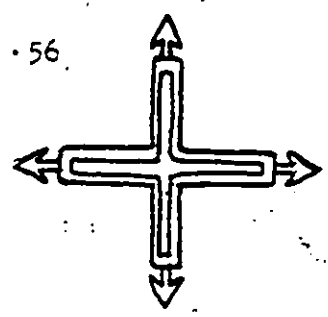
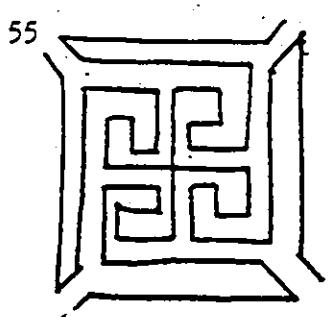
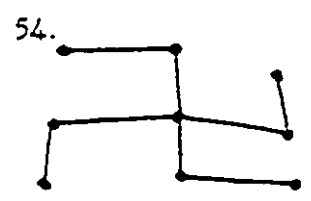
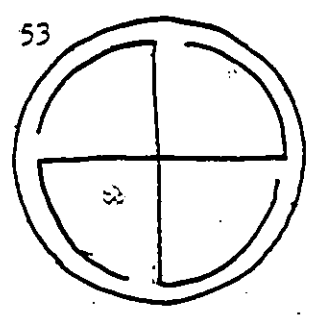
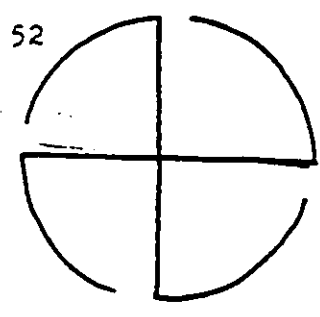
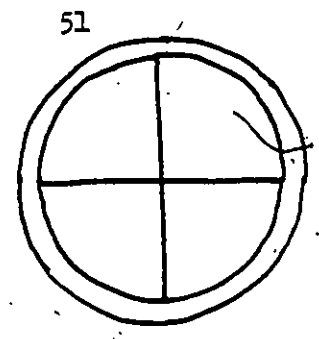
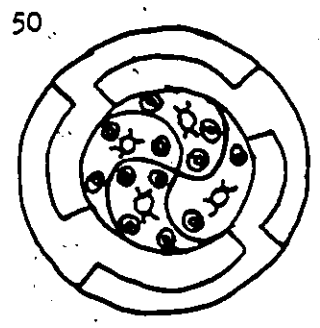
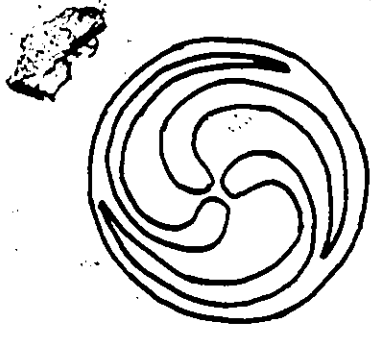

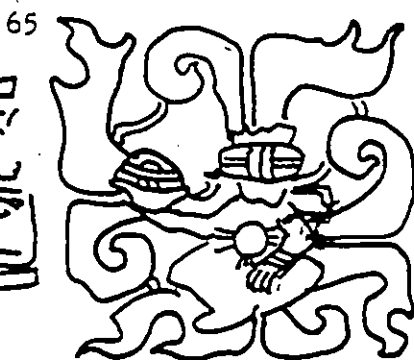
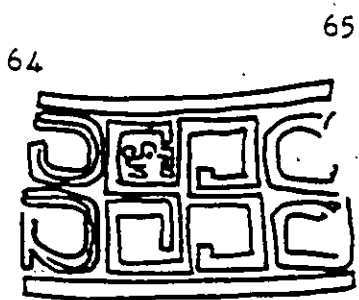
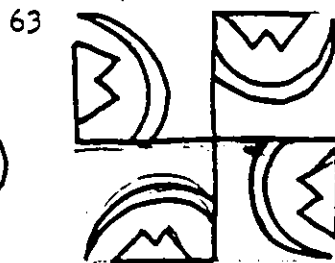
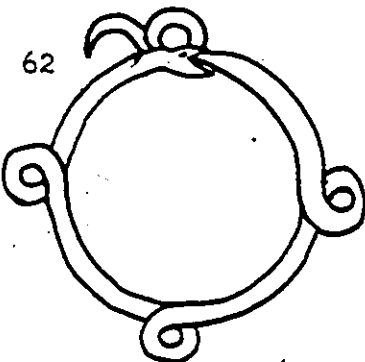
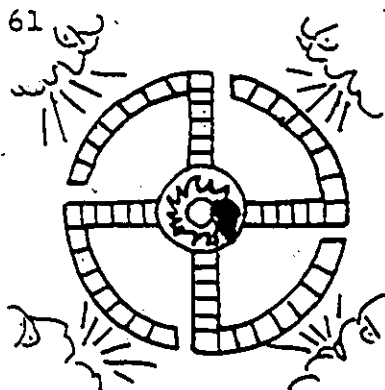

66

67



68



69

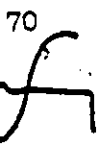

70



71



72

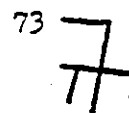

73



74

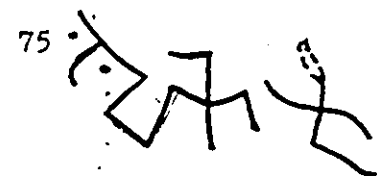

75

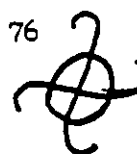

76



77

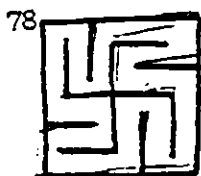

78

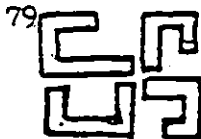

79

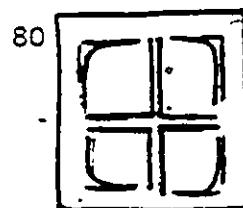

80

81

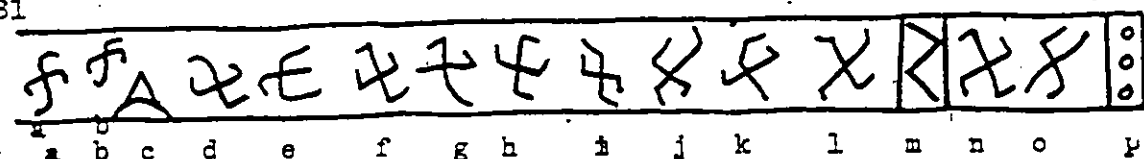

a b c d e f g h i j k l m n o p

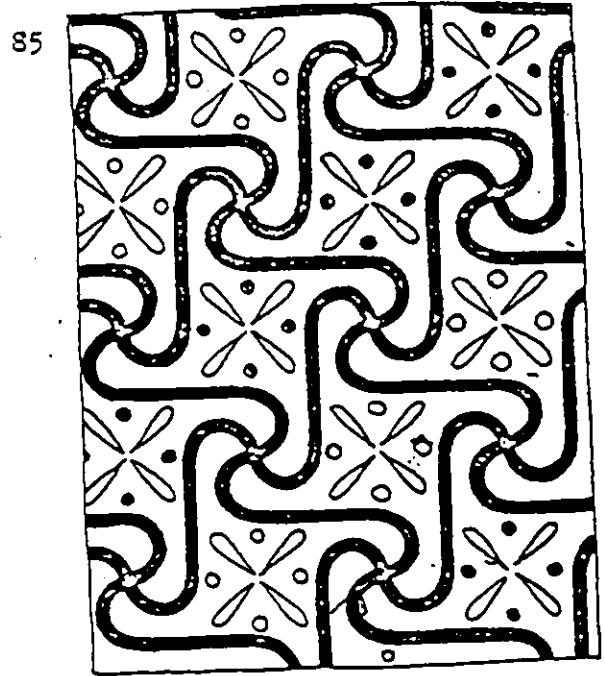
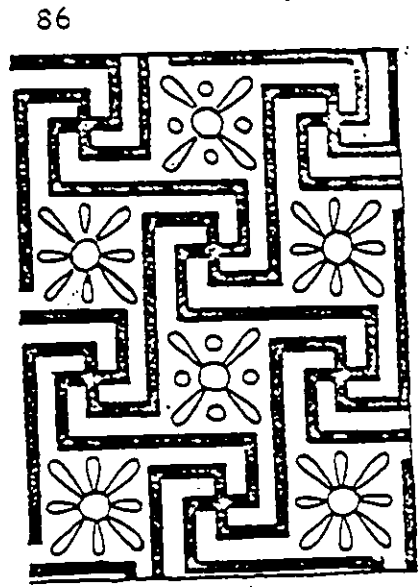
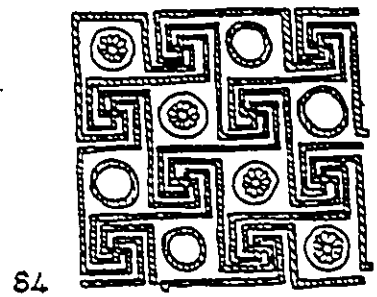
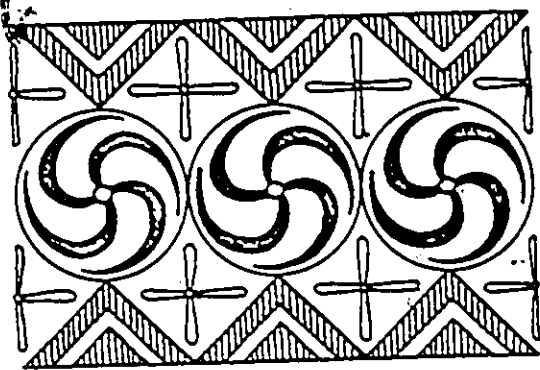
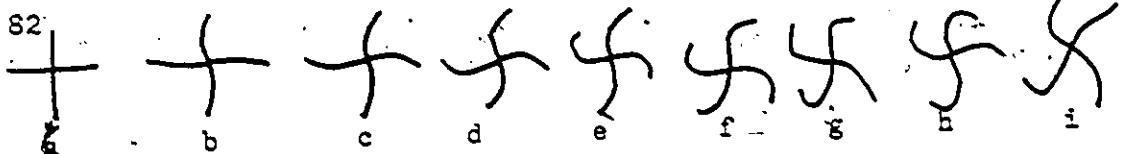

Appendix 2

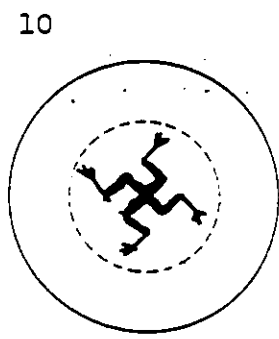
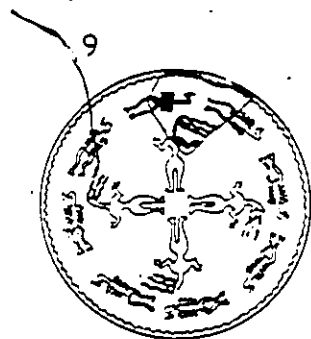
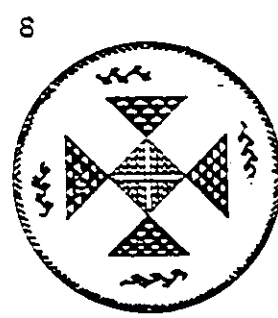
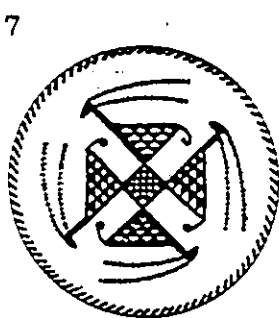
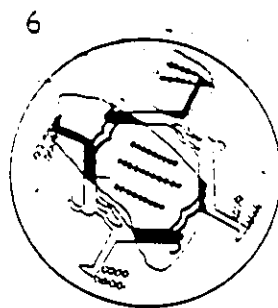
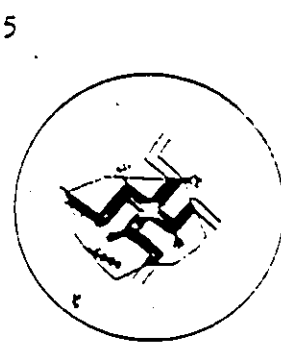
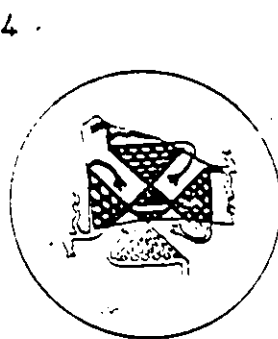
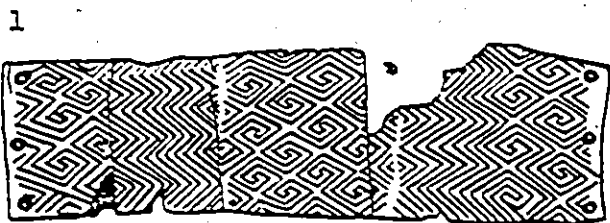

Patterns in Basketry

(fig. 18-cont'd.)

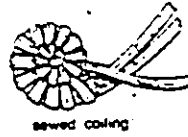
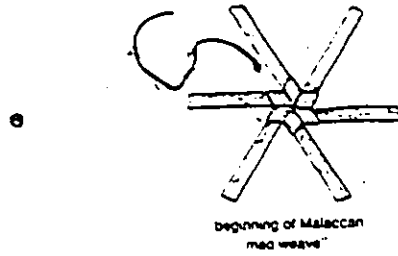
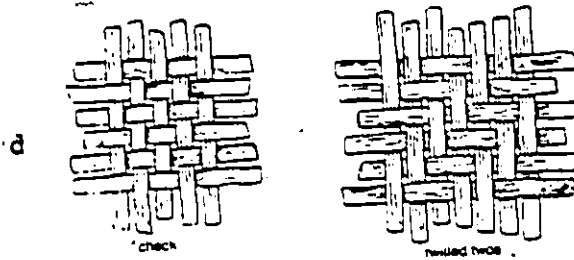

19

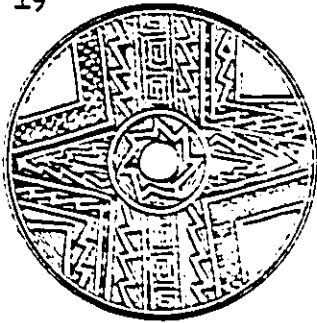

20

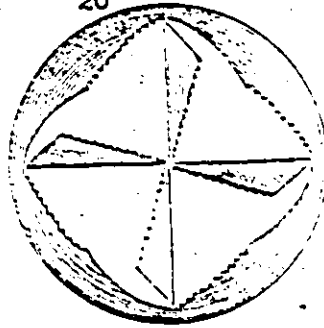

21

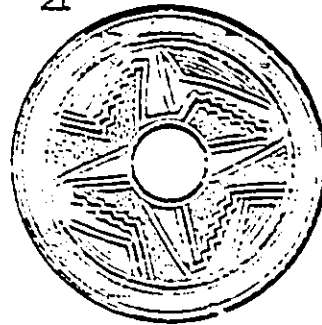

22



23

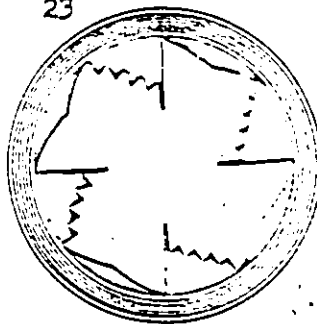

24



25

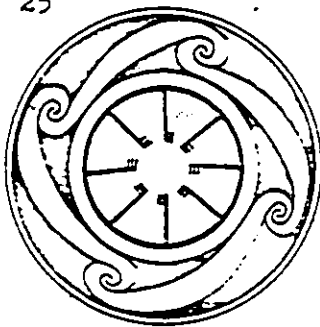

26

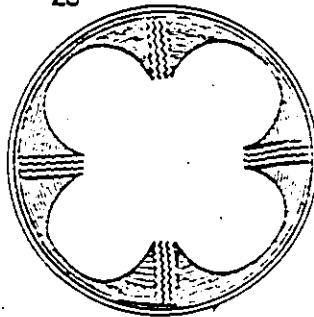

27

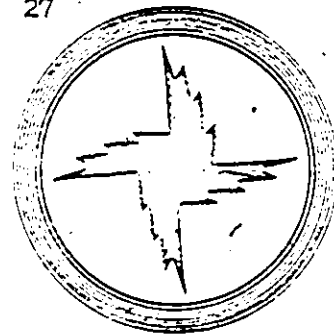

28

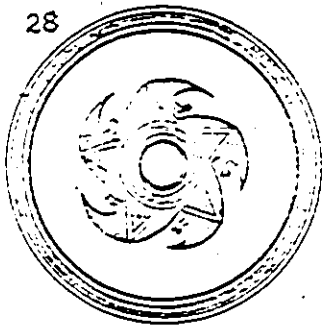

29

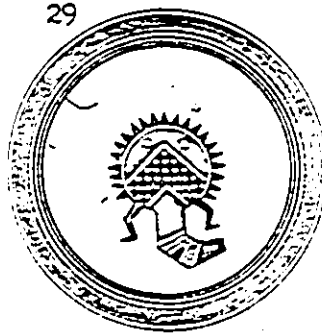

30



Samarran sites and Indo-European Migration

1

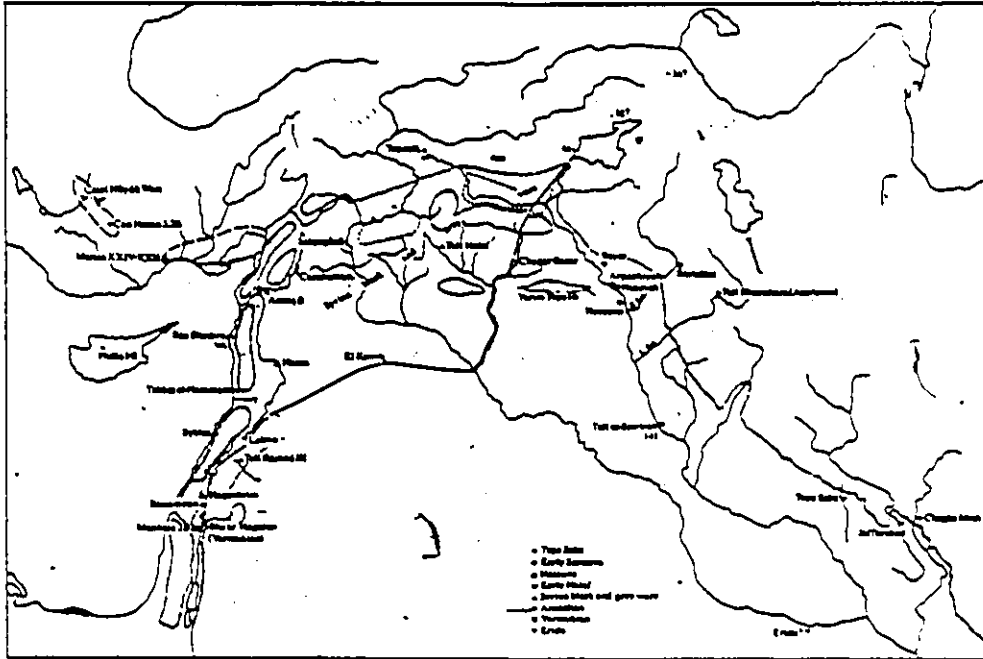

2

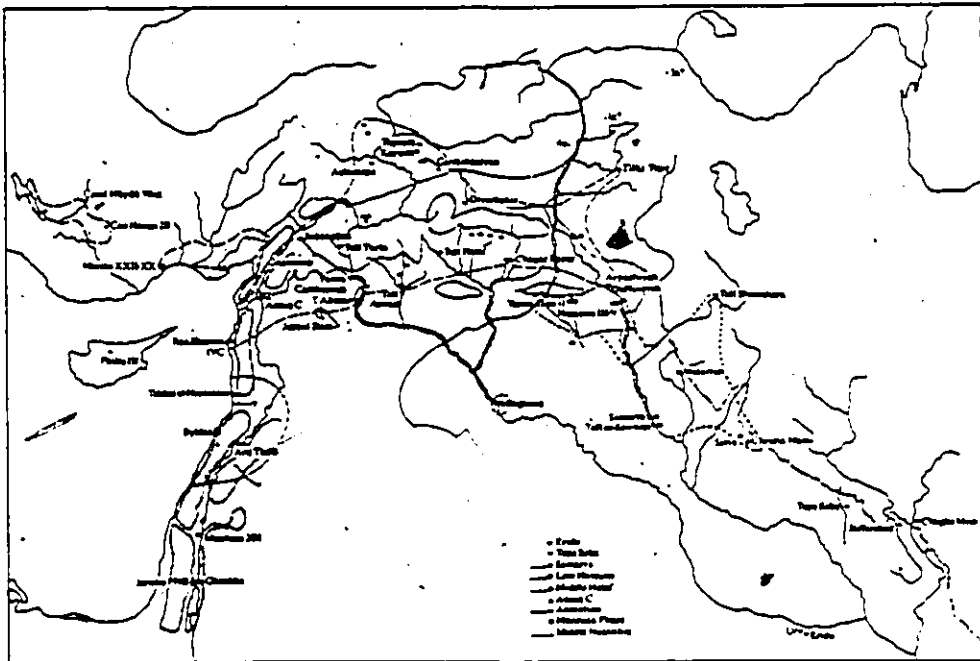

Samarran sites.¹

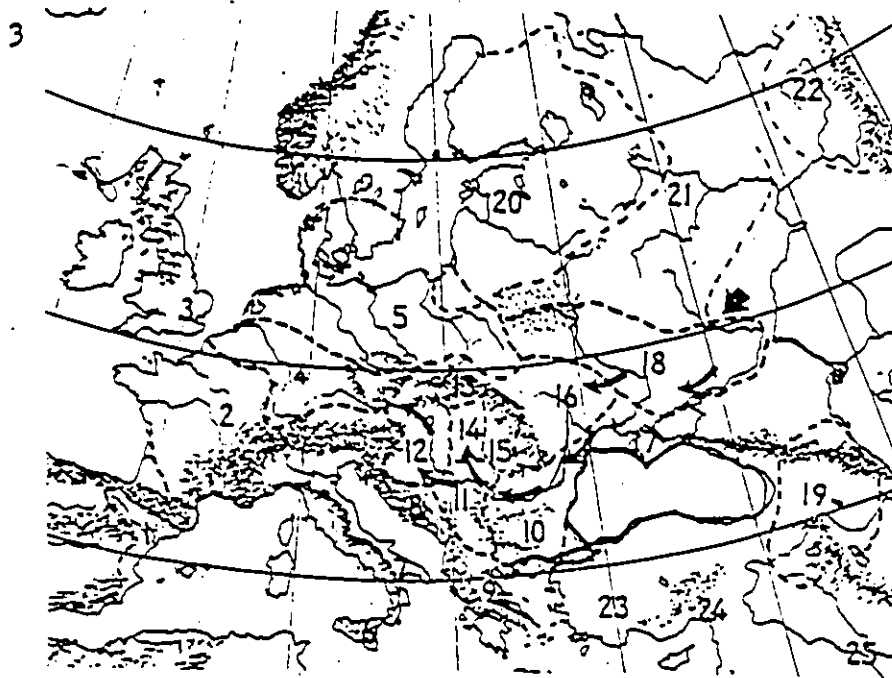
Indo-European Migration²

European and Near Eastern cultures during the fifth and fourth millennium B.C., and the Kurgan infiltration (arrows) into the Danube basin in the first half of the fourth millennium B.C.

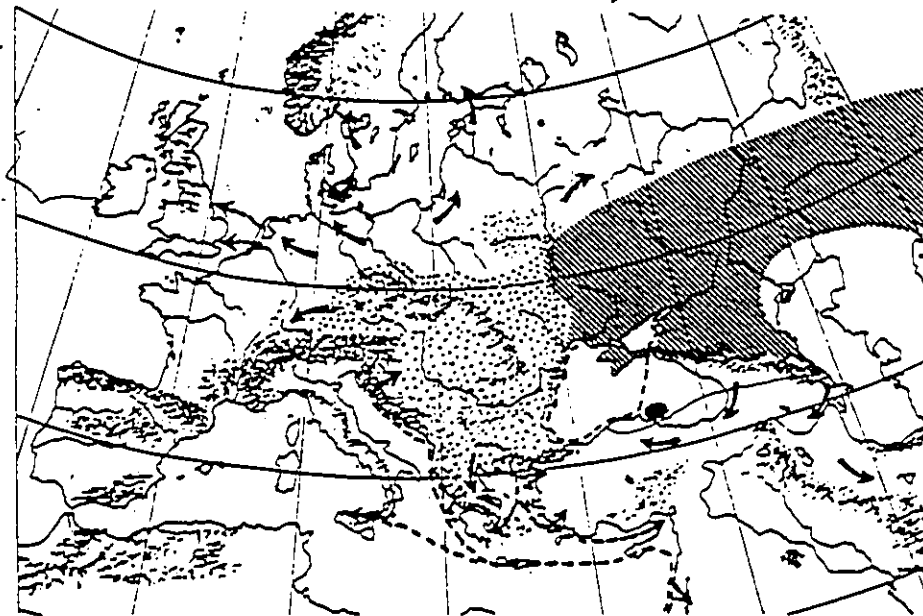
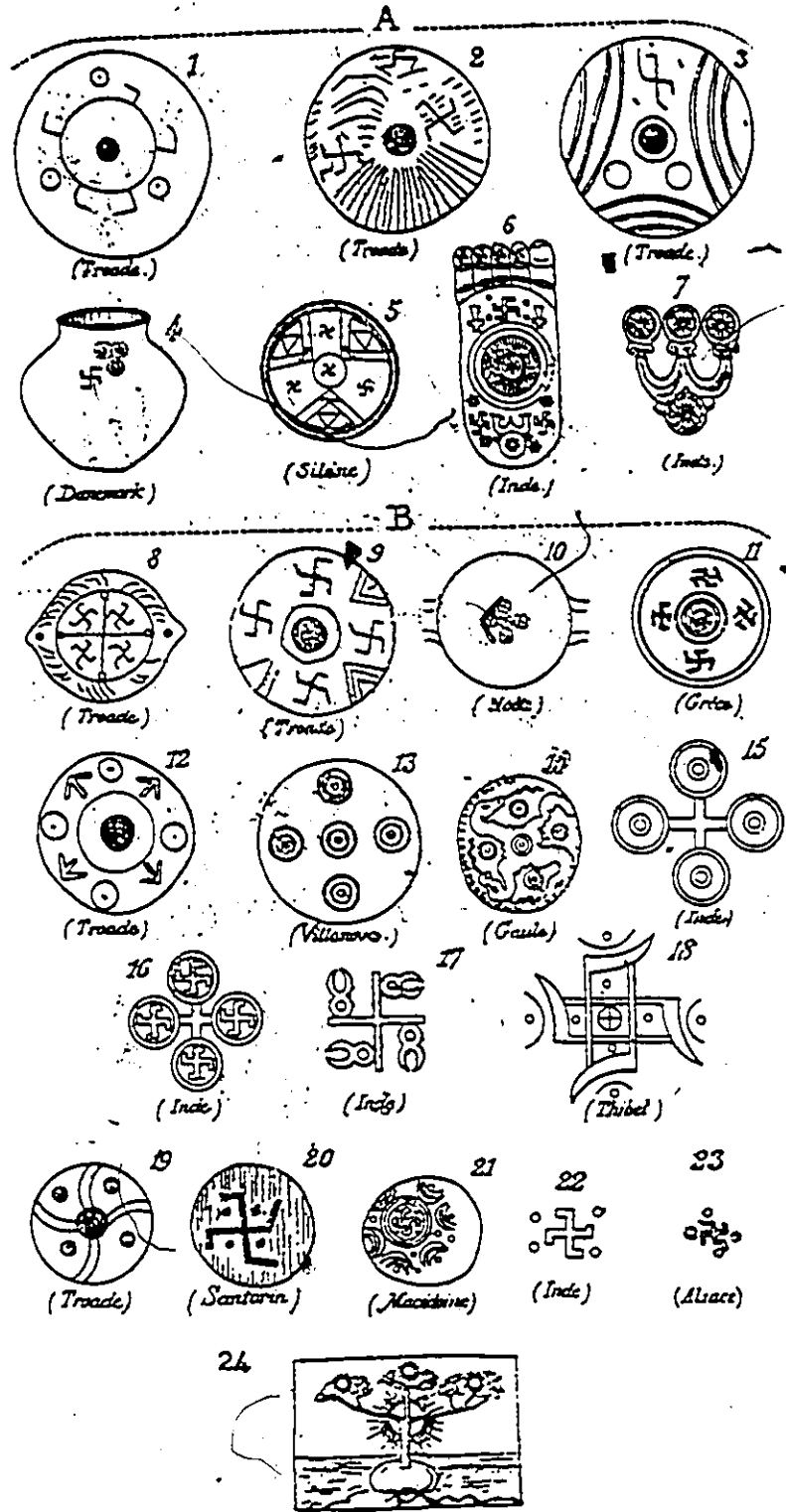

FIG. 27. Kurgan culture during the fourth and third millennia and the climax of expansions. *Solid gray area*: Kurgan culture in the Eurasian steppes. *Dotted area*: The area infiltrated not later than 4000-3500 B.C. *Arrows* show tentative movements after ca. 2500 B.C. *Disconnected line and arrows* indicate possible sea-ways, raids, and destruction at ca. 2300 B.C.



D'Altiella's "Plate II"

C



FIG. 25. From an Assyrian Cylinder.



FIG. 26. From a Phoenician Bowl.



FIG. 27. Lappala Coin of Myra in Lycia.

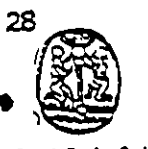

FIG. 28. Persian Seal.



FIG. 29. Indian Sculpture.



FIG. 30. Indian Sculpture.

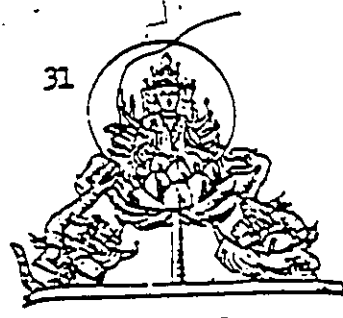

FIG. 31. Japanese Group.

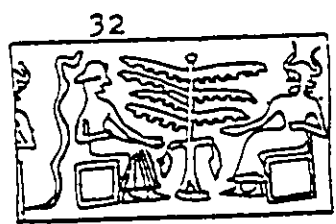

FIG. 32. From a Chaldean Cylinder.



FIG. 33. Japanese Coin.

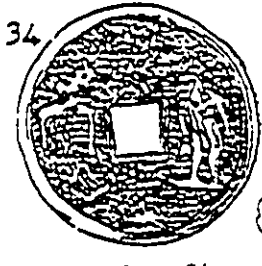

FIG. 34. Japanese Coin.



FIG. 35. Mexican Manuscript.

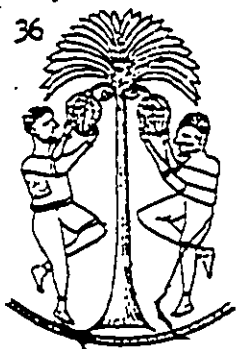

FIG. 36. Syrian Ornamentation.



FIG. 37. Silesian Engraving.

Tree of Life Symbols

D



FIG. 38. Bas-relief of Nineveh.



FIG. 39. From a Phoenician Bowl.

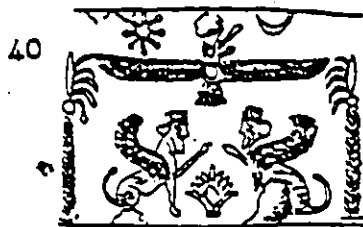

FIG. 40. From a Persian Cylinder.



FIG. 41. From a Sassanian Bowl.



FIG. 42. Capital of the Temple of Athens at Priene.



FIG. 43. Archaic Vase of Athens.



FIG. 44. Bas-relief of the Taptirary of Cividale.

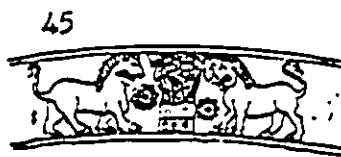
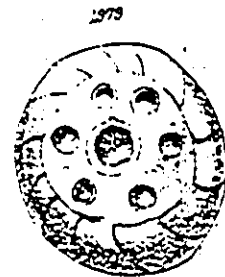
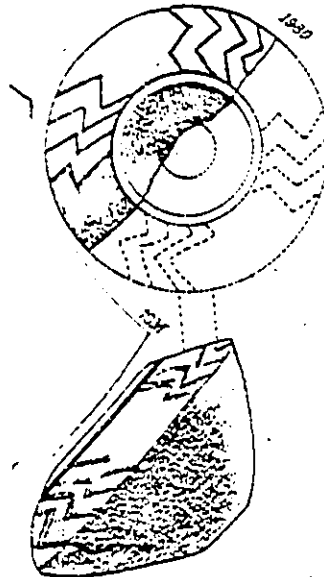
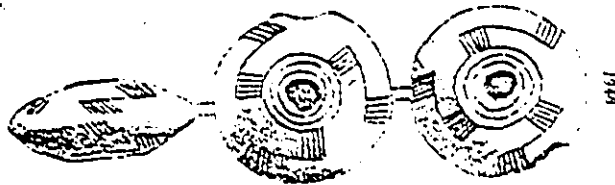
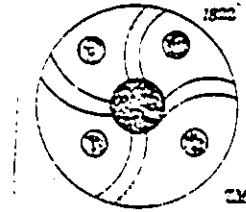
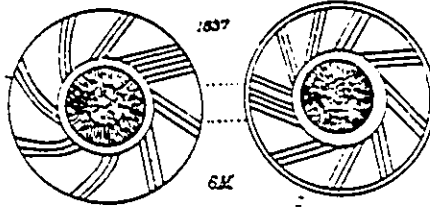

FIG. 45. Bas-relief of Echarbur.

Tree of Life Symbols

Trojan spindle-whorls

A. (Rotation)



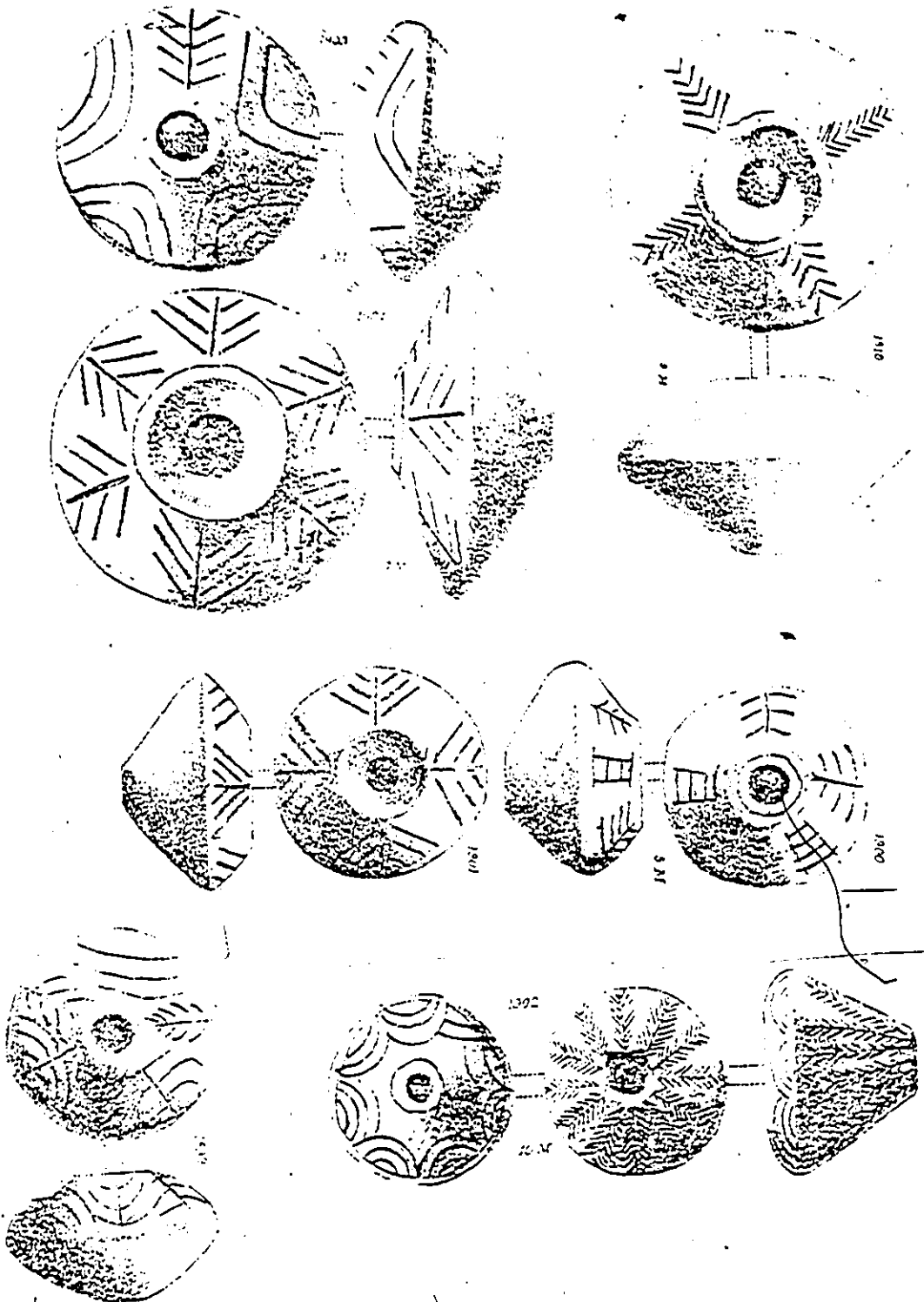

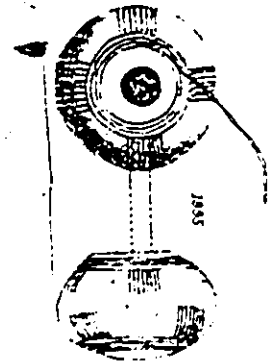
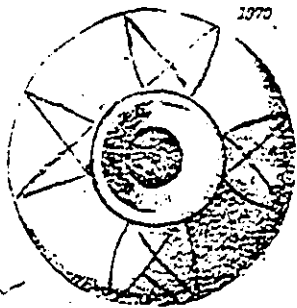
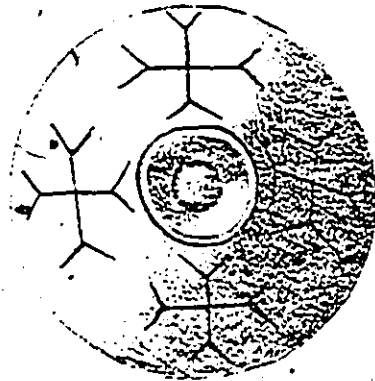
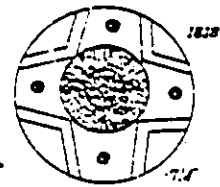
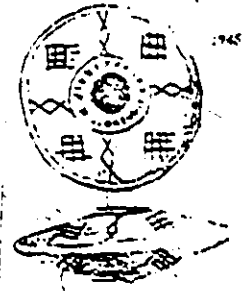
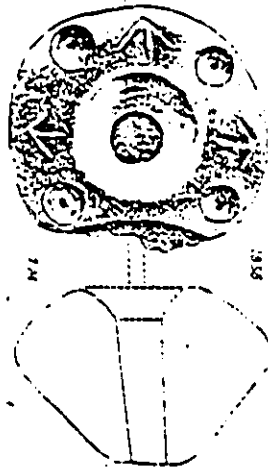
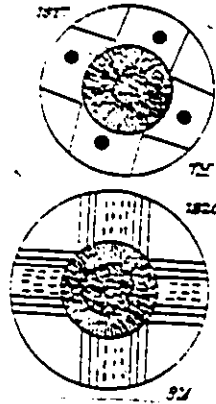

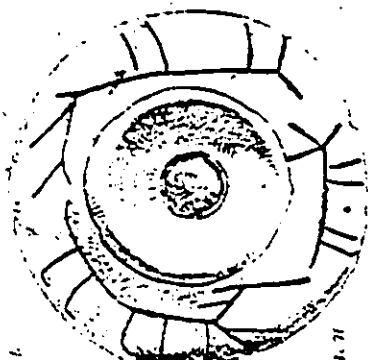

1874

1874

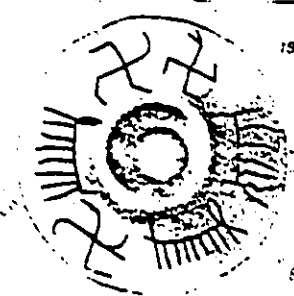

1872

5M

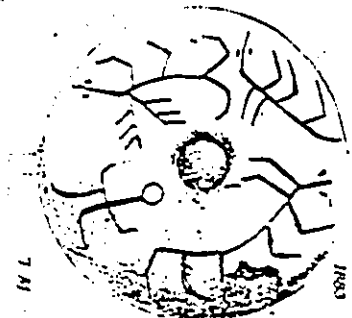

1883

1883

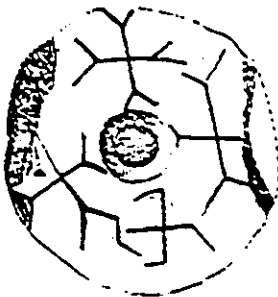

1879

4A

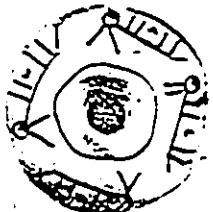
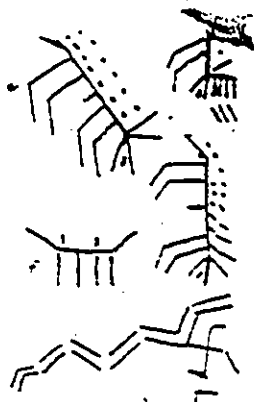

1867

11

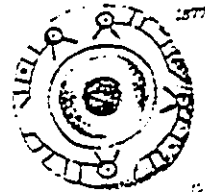
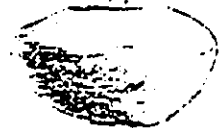
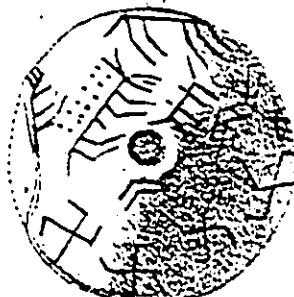

1857

12



1880

6 X

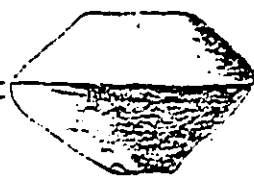



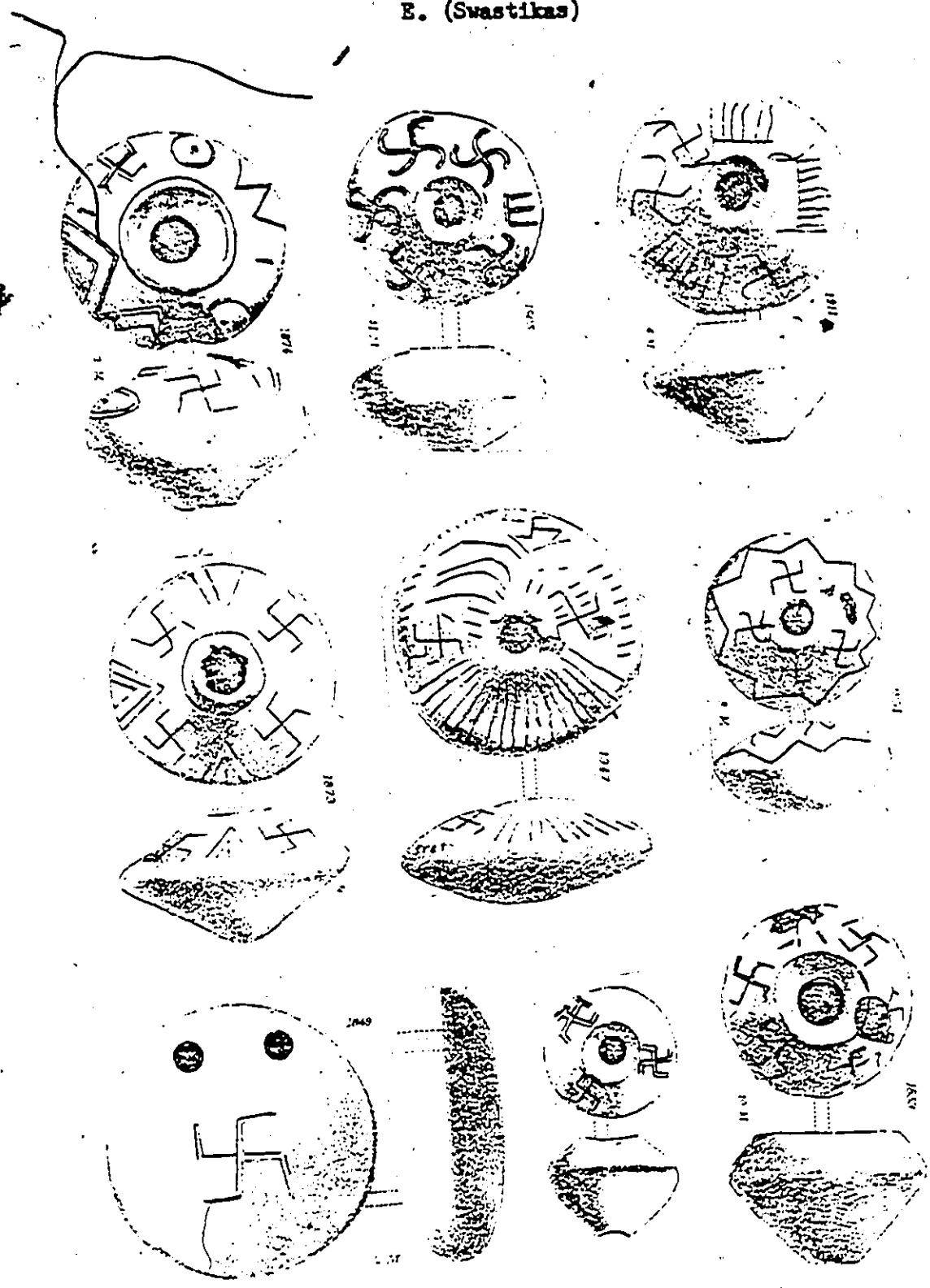

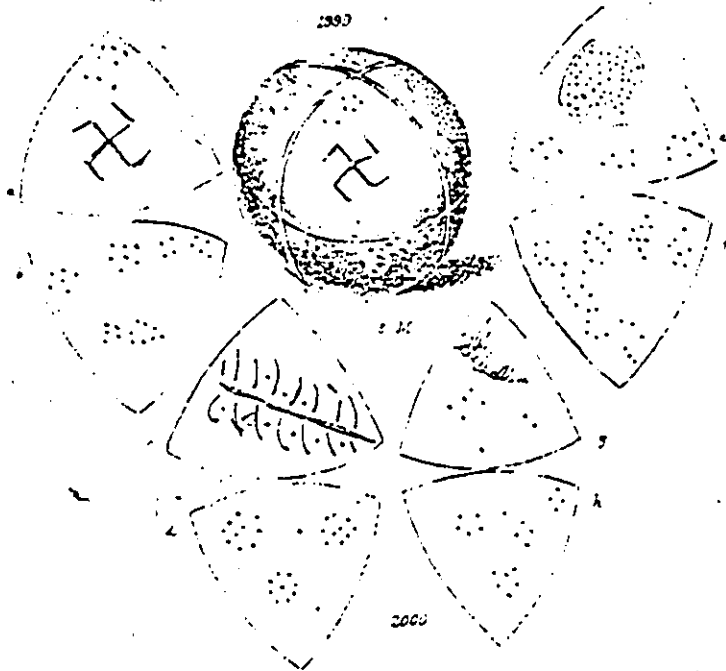
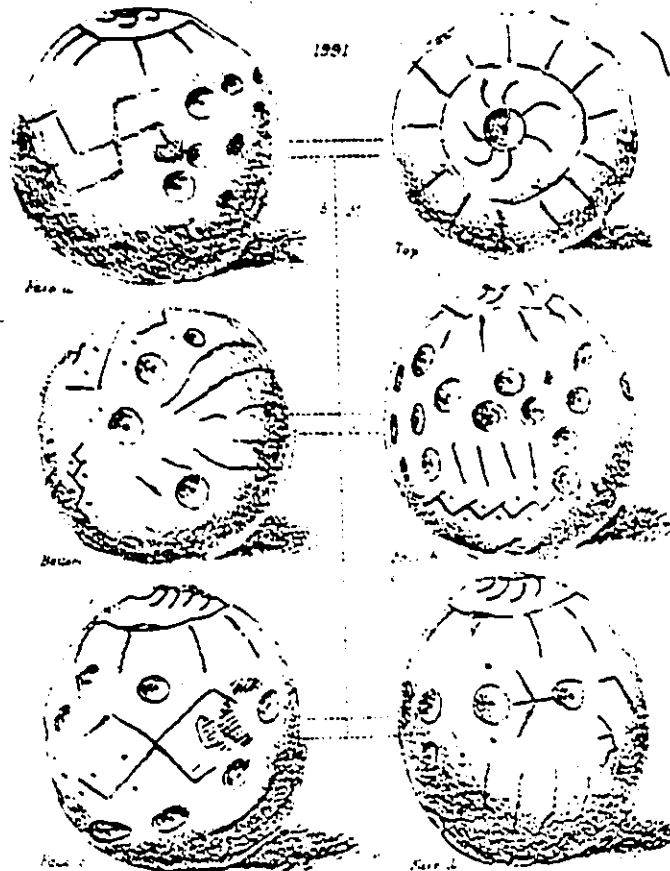

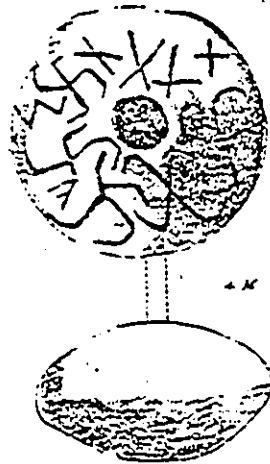
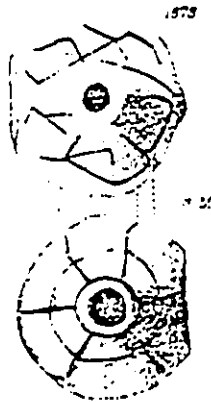
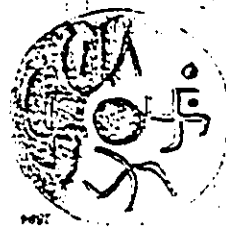
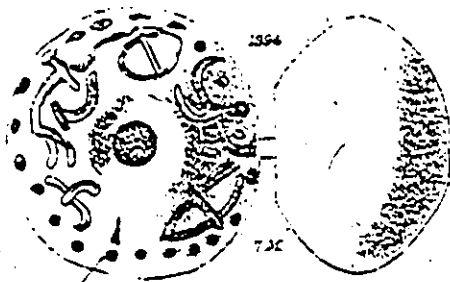
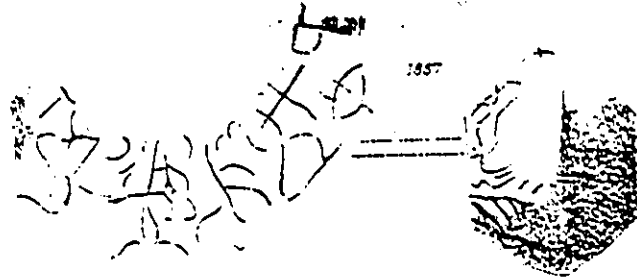











E. (Swastikas)







DATE B.C.	MESOPOTAMIA							IRAN		INDIA GUJARAT	DATE B.C.
	PERIODS	LARSA	KISH	ASMAR	UR	GAWRA	ERAK	SUSA	HISSAR	LOTHAL	
1600											1600
Indus and Sumerian objects suggestive of trade contacts between Lothal and West Asia.											
1700	OLD BABYLONIAN										1700
1800					MARSH PORT						1800
1900	ISIN LARSA 1897-1762				LARSA PERIOD TOWN						1900
2000					AMARIN SHULGI TOMBS						2000
2100	UR THIRD DYNASTY 2112-2006				UR NABUCCI TIGORAT						2100
2200	POST AKKAD 2230-2130				UR GRAVES						2200
2300	AKKAD 2371-2253	GUDEA		ABU TEMPLE	LARSOND GRAVES	GAWRA VI	LARSOND LEVEL VI		HISSAR III		2300
2400	EARLY DYNASTY IIIA		A CEMETERY		AMARATA ROYAL CEMETERY	GAWRA VII		SUSA D6	HISSAR IIIA		2400
2500								SUSA D4	HISSAR IIB		2500

REFERENCES	
ETCHED CARNELIAN BEAD	
DOUBLE SPIRAL RING	
INDUS SEAL	
INDUS WEIGHT	
SHELL INLAY	
COPPER DOG	
GAMESMAN	
BIRD-HEADED PIN (COPPER)	
RESERVED SLIP WARE	
SPACER BEAD (GOLD, COPPER ETC)	
HOLLOW CONICAL PENDANT (GOLD ETC)	
SEALING WITH LINEAR SWASTIKA DESIGN	
BUN INGOT (COPPER)	
CYLINDER SEAL WITH INDUS MOTIF	
PERSIAN GULF SEAL	
BEAD WITH AXIAL TUBE (COPPER, SILVER ETC)	
STEATITE DISC BEAD	
BULL AMULET (COPPER SILVER, STONE ETC)	

Indo-European Pottery Design

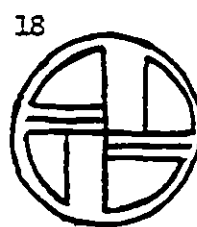
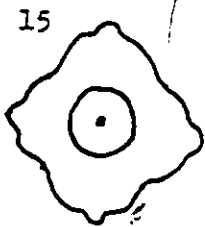
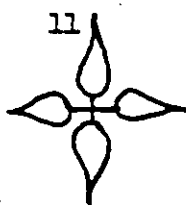
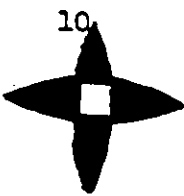
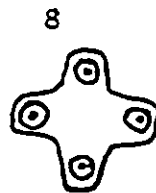
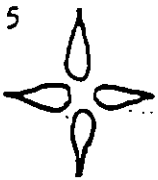
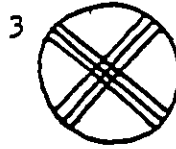
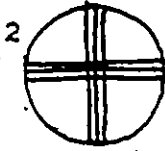
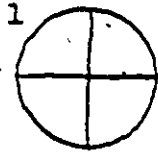



NOTES

Appendix 3, note 1, Mellaart, Neolithic Near East.

Appendix 3, note 1, Gimbutas, "Proto-Indo-European
Culture."

Appendix 4, note 1, D'Alviella, Migration of Symbols.

Appendix 5, note 1, Schliemann, Ilios.

Appendix 6, note 1, Rao, Lothal.

Appendix 7, note 1, Rybakov, "Cosmogony and Mythology."

SELECTED BIBLIOGRAPHY

- Agrawala, V. S. India as Known to Panini: A Study of the Cultural Material in the Ashtadhyayi. Lucknow: University of Lucknow, 1953.
- Akurgal, Ekrem. The Art of the Hittites. Trans. Constance McNab. New York: Harry N. Abrams, 1962.
- Alkim, U. Bahadir. Anatolia. Trans. James Hogarth. Archaeologia Mundi Series. 2 vols. Cleveland: The World Publishing Co., 1968.
- Allan, John. Catalogue of the Coins of Ancient India. n.p.: Trustees of the British Museum, 1967.
- Apte, V. S. The Practical Sanskrit-English Dictionary. Rev. and Enl. Delhi: Motilal Banarsidass, 1975.
- Baird, Robert D. Category Formation and the History of Religion. The Hague: Mouton & Co., 1971.
- Barth, Walter and Kritchlow, Keith. Interview on "90 Minutes Live." Canadian Broadcasting Corporation, December 14, 1976.
- Bauschatz, Paul C. "Urth's Well." The Journal of Indo-European Studies 3 (1975): 53-86.
- Bibliographie der Deutsches Zeitschriften-Literatur; Abteilung A. 99 vols. n.p.: Kraus Reprint Corp., 1961-63.
- Blegen, Carl W. Troy and the Trojans. Ancient People and Places series. no. 32. gen. ed. Glyn Daniel, London: Thames & Hudson, 1963.
- Bloomfield, Maurice. A Vedic Concordance. Poona: Motilal Banarsidass, 1964.
- Buck, Carl Darling. A Dictionary of Selected Synonyms in the Principal Indo-European Languages; A Contribution to the History of Ideas. Chicago: University of Chicago, 1965.
- Budge, E. A. Wallis. Amulets and Talismans. New York: Collier-Macmillan, 1970.

- Bulling, A. The Meaning of China's Most Ancient Art; An Interpretation of Pottery Patterns from Kansu (Ma Ch'ang and Pan-Shan) and their Development in the Shang, Chou and Han Periods. Leiden: E. J. Brill.
- Butterworth, E. A. S. The Tree at the Navel of the Earth. Berlin: Walter de Gruyter & Co., 1970.
- Camman, Schuyler. "The Magic Square of Three in Chinese Religion and Philosophy." History of Religion (1961): 37-80.
- Campbell, Joseph. The Masks of God; Primitive Mythology. Rev. ed. Harmondsworth, England: Penguin Books, 1976.
- Cardona, George; Hoenigswald, Henry M.; and Senn, Alfred. Indo-European and Indo-Europeans, Papers Presented at the Third Indo-European Conference at the University of Pennsylvania. Philadelphia: University of Pennsylvania Press, 1970.
- Chatteryea, Bhaskar. "Iconographic Development of the Sun-God in Early North India." Proceedings of the All-India Oriental Congress. 27th session (1976): 409-413. "Joshi, Svastika--."
- Chikalenko, Levko. "The Origin of the Paleolithic Meander." The Annals of the Ukrainian Academy of Arts and Sciences in the U. S. 3 (1953): 518-534.
- Christenger, Raymond. "The Hidden Significance of the Cretan Labyrinth." History of Religion (1975): 183-191.
- Converse, Hyla Stuntz. "The Agnicayana Rite: Indigenous Origin?" History of Religion (1974): 81-95.
- Cook, Arthur Bernard. Zeus: A Study in Ancient Religion. 2 vols. n.p.: Biblo & Tannen, 1964. 2; 475-476.
- Dales, George F. "A Suggested Chronology of Afghanistan, Baluchistan, and the Indus Valley." In Ehrich, Chronologies. pp. 257-284.
- D'Allirella, Comte Goblet. Migration of Symbols. 1894; Rep. ed., New York: University Books, 1956.
- Danielou, Alain. Hindu Polytheism. Bollingen Series 73. New York: Pantheon Books, 1964.

- Deshayes, Jean. "Dikilitash and the Origins of the Troadic Culture." Archaeology 25 (1972): 198-205.
- Dikshitar, V. R. Ramachandra. The Purana Index. 2 vols. n.p.: University of Madras, 1951.
- Dorson, Richard. "The Eclipse of Solar Mythology." Myth: A Symposium. Ed. Thomas Sebok. Bibliographic and Special Series of the American Folklore Society, no. 5. Philadelphia: Indiana University Press, 1955.
- Dupree, Louis. Prehistoric Research in Afghanistan (1959-1966). Transactions of the American Philosophical Society held at Philadelphia for Promoting Useful Knowledge, n.s. vol. 62, pt. 4 (1972). Philadelphia: American Philosophical Society, April 1972.
- Dyson, "Relative Chronology of Iran." Ehrich, Chronologies in Old World Archaeology.
- Eliade, Mircea. Mephistopheles and the Androgyne. Trans. J. M. Cohen. New York: Sheed and Ward, 1965.
- _____. Patterns in Comparative Religion. Trans. Rosemary Sheed. New York: New American Library (Meridian), 1974.
- Evans, Sir Arthur John. "The Place at Knossos." Annual of the British School at Athens (1902-1903): 1-154.
- Fairservis, Walter A., Jr. The Roots of Ancient India: The Archaeology of Early Indian Civilization. 3rd ed. rev. Chicago: University of Chicago Press, 1975.
- Finkenstaedt, Thomas, Leisi, Ernst, Wolff, Dieter. A Chronological English Dictionary: Listing 80,000 Words in Order of their Earliest Known Occurrence. Heidelberg: Carl Winter Universitaats verlag, 1970.
- Forbes, R. J. Studies in Ancient Technology. 9 vols. Leiden: E. J. Brill, 1955.
- Fried, John H. E. Collin's Encyclopedia.
- Ghosh, A. ed., Indian Archaeology--A Review. 1959-60 (1960) pp. 11-12.
- Gimbutas, Marija. The Gods and Goddesses of Old Europe, 7000-3500 B.C.: Myths, Legends and Cult Images.

- Berkeley: University of California Press, 1974.
- . "On the Origin of the North Indo-Europeans." American Anthropologist 54 (1952): 602-610.
- . "Proto-Indo-European Culture: The Kurgan Culture During the Fifth, Fourth, and Third Millenium B.C." Indo European and Indo-Europeans: Papers Presented to the Third Indo-European Conference at the University of Pennsylvania. Ed. George Cardona, Henry M. Hoenigswald, and Alfred Senn. Philadelphia: University of Pennsylvania, 1970. pp. 155-197.
- Griffith, Ralph T. H. The Hymns of the RgVeda. The Chowkhamba Sanskrit Studies Series, no. 35. 2 vols. Varanasi, India: Chowkhamba Sanskrit Series Office, 1963.
- Grunberger, Richard. The 12-Year Reich: A Social History of Nazi Germany, 1933-1945. New York: Holt, Rhinehart & Winston, 1971.
- Gune, Pandurang Damodar. An Introduction of Comparative Philology. Ed. N. P. Gune. Poona: Poona Oriental Book House, 1962.
- Gupta, Sankar Sen. "A Study of Ganesha: A Distinct Member of the Durga Family in Bengal." Folklore. (Calcutta) 14 (1973): 323-337.
- Heiden, Konrad. Der Fuehrer: Hitler's Rise to Power. Trans. Ralph Manheim. Boston: Houghton Mifflin Co., 1944.
- Hillard, Katherine. An Abridgement of the Secret Doctrine; A Synthesis of Science, Religion, and Philosophy, by Petrova Blavatsky. New York: The Quarterly Book Department, 1907.
- Hitler, Adolf. Mein Kampf. Trans. Ralph Manheim. Houghton Mifflin Co., Sentry ed., 1971.
- Hodge, Frederick Webb. ed. Handbook of American Indians North of Mexico. 2 vols. New York: Pageant Books, Inc., 1960.
- Jackson, A. M. T. Folk Lore Notes. Comp. R. E. Enthoven. 2 vols. Mazgaon, Bombay: British India Press, 1914-15.
- Jacobi, Hermann. Jaina Sutras The Akaranga Sutra and the

- Kalpa Sutra. New ed. The Sacred Book of the East Series, no. 22. Delhi: Motilal Banarsidass, 1964.
- Lechler, Jorg. Vom Hakenkreuz; Die Geschichte eines Symbols. 2nd ed. Leipzig: Curt Kabitzsch Verlag, 1964.
- Joshi, Rasik Vihari. "Svastika--A Solar Symbol of the Aryans." Abstracts of the Proceedings of the All-India Oriental Congress, 37th Session. (1974).
- Jung, Carl Gustav. The Collected Works of C. G. Jung. Trans. R. F. C. Hull. 19 vols. Routledge & Kegan Paul, 1969.
- Kane, P. V. History of Dharmasastra. 5 vols. Government Oriental Series. Bhandarkar Oriental Research Institute, 1962. Vol. 5.
- Lamberg-Karlovsky, C. C. and Lamberg-Karlovsky, Martha. "An Early City in Iran." Scientific American (June 1971): 102-111.
- Lease, Gary. "Hitler's National Socialism as a Religious Movement." Journal of the American Academy of Religion 45 (1977): 351 (Abstract only).
- Lehmann, Winfred P. "Linguistic Structure as Diacritic Evidence on Proto-Culture." Indo European and Indo-Europeans; Papers Presented to the Third Indo-European Conference at the University of Pennsylvania. Eds. George Cardona, Henry M. Hoenigswald and Alfred Senn. Philadelphia: University of Pennsylvania, 1970. pp. 1-10.
- Loewenstein, Prince John. "Swastika and Yin-Yang." Nine Dragon Screen; Being Reprints of Nine Addresses and Papers Presented to the China Society, 1909-1945. London: The China Society, 1965. pp. 5-28.
- MacKay, E. J. H. Further Excavations at Mohenjo-Daro. 2 vols. Delhi: Government of India Press, 1938.
- MacDonnell, Arthur Anthony. A Practical Sanskrit-English Dictionary. Oxford: Oxford University Press, n.d.
- Mackenzie, Donald A. The Migration of Symbols and their Relations to Beliefs and Customs. New York: n.p., 1926; Rep. ed., New York: AMS Press, 1970.
- Mallory, J. P. "A History of the Indo-European Problem." Journal of Indo-European Studies. 1 (1973): 21-65.

- Mallowan, M. E. L.; Cruickshank, Rose J. "Excavations at Tell Arpachiyah: 1933." Iraq 2 (1935): 1-178.
- Marinatos, Sp. "On the Trail of Folklore Elements in Bronze Age Art and Literature." International Congress for Folk-Narrative Research at Athens 4 (1965): 262-273.
- Maringer, Johannes. "Grave and Water in Prehistoric Europe." Journal of Indo-European Studies 3 (1975): 121-145.
- Mellaart, James. "Anatolia and the Balkans." Antiquity 34 (1960): 270-278.
- _____. The Neolithic of the Near East. New York: Charles Scribner's Sons, 1975.
- Mellink, Machteld J. "The Royal Tombs at Alaca Huyuk and the Aegean World." The Aegean and the Near East: Studies Presented to Hetty Goldman on the Occasion of Her 75th Birthday. Ed. Saul S. Weinberg. J. J. Augustin, 1956. pp. 39-58.
- Monier-Williams, Monier. A Sanskrit-English Dictionary: Etymologically and Philologically Arranged with Special Reference to Cognate Indo-European Languages. Oxford: Clarendon Press, 1960.
- Morford, Mark P. O.; Lenardon, Robert J. Classical Mythology. New York: David McKay Co., 1974.
- Mukherji, Kali Nath. Popular Hindu Astronomy. Foreword by N. C. Lahiri. Calcutta: Nirmal Mukherjea, 1969.
- Muller, Max. Comparative Mythology; An Essay. "Introduction" A. Smythe Palmer. incl. "The Oxford Solar Myth." R. F. Littledale. London: George Routledge & Sons, n.d.
- Needham, Joseph. Science and Civilization in China. Collab. Wang Lin. 5 vols. Cambridge: University Press, 1959.
- Nuttall, Zenia. The Fundamental Principles of Old and New World Civilizations: A Comparative Study Based on a Study of Ancient Mexican Religious, Sociological, and Calendrical Systems. Archaeological and Ethnological Papers of the Peabody Museum, Harvard University, no. 2. Cambridge, n.p., 1900; Rep. ed., New York: Kraus Reprint, 1970.

- Oates, Joan. "Choga Mami, 1967-68: A Preliminary Report." Iraq 31 (1969): 115-151.
- _____. "Early Farming Communities in Mesopotamia; The Samarran Phase." Journal of the Proceedings of the Prehistoric Society 39 (1973): 165-172.
- Perry, John Weir. Lord of the Four Quarters; Myths of the Royal Father. Patterns of Myth Series, gen. ed. Alan W. Watts. New York: George Braziller, 1966.
- Propp, Ja V. Morphology of the Folktale, 2nd ed. Rev. and ed. Louis A. Wagner. New Introduction, Alan Dundes. Anthropology, Folklore, and Linguistics Series, no. 10. Bloomington, Indiana: Indiana University Research Centre for the Language Sciences, 1968.
- Pusalker, A. D. "The Indus Valley Civilization." The Vedic Age. The History and Culture of the Indian People Series, no. 1, gen. ed. R. C. Majumdar. Bombay: Bharatiya Vidya Bhavan, 1965. pp. 172-292.
- Sheshadri, R. trans. The 'Raghuvamsa'; Sri Kalidasa's Great Epic. Foreword, K. S. Ramaswami Sastriar. 1939.
- Rao, S. R. Lothal and the Indus Civilization. Foreword by Sir Mortimer Wheeler. New York: Asia Publishing House, 1973.
- Renfrew, Colin. Before Civilization: The Radio Carbon Revolution and Prehistoric Europe. Harmondsworth, Eng.: Penguin Books, 1976.
- Rybakov, B. A. "Cosmogony and Mythology of the Agriculturalists of the Eneolithic." Soviet Anthropology and Archaeology 4 (1965-66): 16-38 and 33-54.
- Sankalia, Hasmuth Dhirajlal; Subbarao, Bendapudi; Deo, Shantaram Balchandra. The Excavations at Maheshwar and Navdatoli, 1952-1953. Poona: Baroda, 1958.
- Sarma, K. V. ed. The 'Goladipika' by Paramesvara. Adyar Library Pamphlet Series, no. 32. Adyar, India: Adyar Library and Research Centre, 1957.
- Sarup, Lakshman. (ed. and trans. The Nighantu and the Nirukta. Delhi: Motilal Banarsidass, 1967.
- Sasso, Michael. "Orthodoxy and Heterodoxy in Taoist Ritual." Religion and Ritual in Chinese Society, ed. Arthur

- Stanford: Stanford University Press, 1974. pp. 325-336.
- _____. Taoism and the Rite of Cosmic Renewal. n.p.: Washington State University Press, 1972.
- Schick, K. P. English-Hungarian; Hungarian-English Dictionary.
- Schliemann, Henry. Ilios: The City and Country of the Trojans. Rep. ed. New York: Benjamin Blom, 1968.
- _____. Troja: Results of the Latest Researches and Discoveries on the Site of Homer's Troy, 1082. Rep. ed. New York: Benjamin Blom, 1968.
- Sebeok, Thomas. "Six Species of Signs: Some Propositions and Strictures." Semiotica 13 (1975): 233-260.
- Shepard, Anna O. Ceramics for the Archaeologist. Washington: Carnegie Institution of Washington, 1965.
- Sperling, Jerome W. "Kum Tepe in the Troad." Hesperia 45 (1976): 303-364.
- Stein, Sir Aurel. "An Archaeological Tour in Ancient Persis." Iraq 3 (1936): 1-226.
- Stewart, J. A. The Myths of Plato. Centaur Classics Series, gen. ed. J. M. Cohen. London: Centaur Press, 1960.
- Van Buren, Paul. The Edges of Language: An Essay in the Logic of Religion. London: SCM Press, 1972.
- Ver Eecke, Wilfried. "The Symbol as a Philosophical Concept." International Journal of Symbology 6 (1975): 20-30.
- Vermeule, Emily Townsend. "Mythology in Mycenaean Art." Classical Journal 54 (1958): 96-107.
- Villasenor, David V. Tapestries in Sand; The Spirit of Indian Sandpainting. ed. Vinson Brown. Foreword by Vinson Brown. Healdsburg, California: Naturograph Co., 1963.
- Walker, Benjamin. Hindu World. 2 vols.
- Wilson, Thomas. "The Swastika, the Earliest Known Symbol, and Its Migrations; With Observations on the Migration of Certain Industries in Prehistoric Times." Report of the U.S. National Museum Under the Direc-

tion of the Smithsonian Institution for the Year
Ending June 30, 1894. Washington: Government Print-
ing Office, 1896. pp. 757-1011.

Winn, Milton McChesney. "The Signs of the Vinca Culture--
An Internal Analysis: Their Role, Chronology, and
Independence from Mesopotamia." (Ph.D. dissertation,
UCLA, 1973; Rep. ed., Ann Arbor: University Micro-
films, 1978).

Zimmer, Heinrich. Myths and Symbols in Indian Art and
Civilization. Bollingen Series VI, ed. Joseph
Campbell. Princeton: Princeton University Press,
1974.

VITA AUCTORIS

Education

- 1961. Graduated, North Salem High School, Salem, Oregon.
- 1967. Attended Oregon College of Education, Monmouth, Oregon.
- 1970. Graduated, George Brown College of Applied Arts and Sciences, Toronto, Ontario. Certificate of Off-set Lithography.
- 1976. Graduated, University of Windsor, Windsor, Ontario. Bachelor of Arts (Honors), Religious Studies.
- 1977-
1978. Attended University of Windsor, Windsor, Ontario. Master of Arts, Religious Studies.

Professional Experience

- 1967. Psychiatric Nursing, Oregon State Hospital, Salem, Oregon.
- 1973-
1975. Manager, Coles Book Stores, Rexdale, Ontario.
- 1976. 1st Prize, Canadian Society for the Study of Religion Undergraduate Essay Contest.
- 1977. Board of Governor's Medal for Outstanding Scholarship, University of Windsor, Windsor, Ontario.
- 1978. Paper, delivered before the Canadian Society for Asian Studies, Guelph, Ontario.
- Sessional Instructor, University of Windsor.