



2014

## Eligibility Testing at Three Prehistoric Sites at Lynch Creek, Lampasas County, Texas

J. Michael Quigg

Paul M. Matchen

Robert A. Ricklis

Shannon Gray

Charles D. Frederick

charlesthegeoarchaeologist@gmail.com

*See next page for additional authors*

Follow this and additional works at: <http://scholarworks.sfasu.edu/ita>

 Part of the [American Material Culture Commons](#), [Archaeological Anthropology Commons](#), [Cultural Resource Management and Policy Analysis Commons](#), [Historic Preservation and Conservation Commons](#), [History Commons](#), [Human Geography Commons](#), [Other Anthropology Commons](#), [Other Arts and Humanities Commons](#), [Other History of Art, Architecture, and Archaeology Commons](#), [Other Social and Behavioral Sciences Commons](#), and the [Technical and Professional Writing Commons](#)

Tell us how this article helped you.

### Recommended Citation

Quigg, J. Michael; Matchen, Paul M.; Ricklis, Robert A.; Gray, Shannon; Frederick, Charles D.; and Barrett, Jason (2014) "Eligibility Testing at Three Prehistoric Sites at Lynch Creek, Lampasas County, Texas," *Index of Texas Archaeology: Open Access Gray Literature from the Lone Star State*: Vol. 2014 , Article 5. <https://doi.org/10.21112/ita.2014.1.5>

ISSN: 2475-9333

Available at: <http://scholarworks.sfasu.edu/ita/vol2014/iss1/5>

---

# Eligibility Testing at Three Prehistoric Sites at Lynch Creek, Lampasas County, Texas

## **Authors**

J. Michael Quigg, Paul M. Matchen, Robert A. Ricklis, Shannon Gray, Charles D. Frederick, and Jason Barrett

## **Licensing Statement**

This is a work for hire produced for the Texas Department of Transportation (TxDOT), which owns all rights, title, and interest in and to all data and other information developed for this project under its contract with the report producer. The report may be cited and brief passages from this publication may be reproduced without permission provided that credit is given to TxDOT and the firm that produced it. Permission to reprint an entire chapter, section, figures or tables must be obtained in advance from the Supervisor of the Archeological Studies Branch, Environmental Affairs Division, Texas Department of Transportation, 125 East 11th Street, Austin, Texas, 78701

# Eligibility Testing at Three Prehistoric Sites at Lynch Creek, Lampasas County, Texas

By:

J. Michael Quigg, Paul M. Matchen, Robert A. Ricklis,  
Shannon Gray, Charles D. Frederick, and Jason Barrett

with contributions by

J. Phil Dering, Steven Bozarth, Linda Perry, Byron Sudbury, and Bruce Hardy



Prepared for:  
Texas Department of Transportation  
Environmental Affairs Division  
Archeological Studies Program  
Report No. 161  
Austin, Texas

Prepared by:  
TRC Environmental Corporation  
TRC Technical Report  
Nos. 43243 (106892), 18125, and 201313  
Austin, Texas

Texas Antiquities Committee Permit No. 3494

2014

## **EXECUTIVE SUMMARY**

In August 2004, archeologists from the Cultural Resources Section of the Planning, Permitting and Licensing Practice of TRC Environmental Corporation's Austin office conducted National Register eligibility testing and geoarcheological documentation at three previously unrecorded prehistoric sites, 41LM49, 41LM50, and 41LM51, at two separate bridge crossings over Lynch Creek (TxDOT Project CSJ: #0231-15-032; designated East and West) by Farm to Market Road 580W (FM 580W) in western Lampasas County, Texas. This archeological investigation was necessary under the requirements of Section 106 of the National Historic Preservation Act (NHPA), the implementing regulations of 36CRF Part 800 and the Antiquities Code of Texas (Texas Natural Resource Code, Title 9, Chapter 191 as amended) to assess eligibility of all three cultural resource sites for listing on the National Register of Historic Places (NRHP) and for designation as a State Antiquities Landmark (SAL). This eligibility assessment was for the Texas Department of Transportation (TxDOT), Environmental Affairs Division under a Scientific Services Contract No. 573XXSA006 (Work Authorization No. 57315SA006). The analysis and reporting were conducted under contracts 575XXSA008 (Work Authorization 57510SA008), 577XXSA003 (Work Authorization No. 57704SA003) and 571XXSA003 (Work Authorization 57113SA003). All work was performed under Texas Antiquities Committee Permit No. 3494, issued by the Texas Historical Commission (THC) prior to the planned replacement of the two bridges. The materials, artifacts, records, and photographs will be curated at Texas Archeological Research Laboratory (TARL) in Austin.

The field assessment of these three previously unrecorded prehistoric sites was accomplished by mapping the portions of the sites within the proposed area of potential effect (APE, the

temporary easements), documentation of archeological contents through a total of 21 hand-excavated 1-by-1 meter (m) test units that totaled 17.2 m<sup>3</sup> in conjunction with excavation of five mechanical trenches that totaled 51 linear meters, profiling of 17+ m of the portion of the burned rock mound (BRM) present within the APE, and geoarcheological documentation of the Holocene deposits.

Site 41LM49 is a burned rock midden site on the northeastern side of Lynch Creek Bridge East. The site contains minimal cultural materials and burned rock features within the existing FM 580W right-of-way, but minimally two and a half mounds are present beyond the existing right-of-way. Cultural materials within the existing right-of-way are mainly from BRM 1, underlying the right-of-way fence. A profile was created, drawn, photographed, and sampled along a linear section of BRM 1 to document the subsurface of this feature under the current right-of-way fence line. On the opposite side of the roadway from BRM 1, one of the two mechanical trenches exposed a small, buried burned rock feature at approximately 90 centimeters below surface (cmbs), and a 1-by-1 m test unit (0.4 m<sup>3</sup>) targeted a possible cultural zone between 170 and 210 cmbs. No new right-of-way was planned for this locality, and site 41LM49 would not be further impacted by bridge replacement activities. Based on the investigations conducted within the existing right-of-way at 41LM49, it became apparent that limited to no intact cultural deposits remain within the existing right-of-way. Consequently, the investigated portion of site 41LM49 does not contain sufficient information pertinent to answering research questions about local or regional prehistory under NRHP Criterion D. Therefore, the part of site 41LM49 within the existing right-of-way is recommended as not eligible for listing on the NRHP or for designation as a SAL. No further



archeological investigations are recommended for the portion of site 41LM49 within the existing right-of-way.

Site 41LM50 is a buried terrace campsite on the southwestern side of Lynch Creek Bridge East. The assessment of a proposed 10 m wide by 109 m long proposed easement for a low-water crossing was accomplished through mapping the proposed easement, hand-excavating 6.5 m<sup>3</sup> in nine test units, mechanically excavating two trenches (23 linear meters), and documenting the upper 2.5 m below surface of alluvial deposits in those trenches. At least one shallowly buried, well-defined and radiocarbon datable Late Prehistoric component was present in the top 30 centimeters below surface (cmbs), with possibly a second deeper dispersed component in the top 80 cmbs of alluvial deposits sampled.

The upper component appeared concentrated within the 30 m closest to the creek. It is represented by one Bonham and one Alba arrow point, 31 formal and informal stone tools, 643 scattered lithic debitage, both scattered and clustered burned rocks, and minimally two burned rock features (Features 1 and 2). Two radiocarbon dates derived from wood charcoal from Feature 2, plus two from burned rock residues from Feature 1, document this Late Prehistoric component to within the last 430 years. Within this Late Prehistoric component, minimally two curated Late Archaic dart point fragments (one Pedernales and one Marcos) were present, as were a few modern animal bone fragments (deer size) intermixed within or just above the Late Prehistoric materials in the upper 10 cmbs.

Lower in the Holocene alluvial deposits between 50 and 80 cmbs, vertically and horizontally scattered lithic debitage, scattered charcoal, and the occasional stone tool (7 edge-modified flakes, 1 biface, and 1 scraper) were present. These artifacts may represent displaced materials from the overlying component, or minimally one dispersed lower component. Some burned rocks, but no

diagnostic artifacts or features were encountered within this deeper 30 cm thick zone. Two radiocarbon dates derived from isolated wood charcoal from 67 to 80 cmbs yielded dates of 930 B.P. and 950 B.P. and may document the age of these scattered materials. The absence of recognizable cultural features, combined with the limited, dispersed debitage and burned rocks hinder our understanding of this deeper material.

The investigated portion of site 41LM50, located within the proposed easement/APE, contains minimally one well-defined component of Late Prehistoric age (less than 430 B.P.) that has the potential to yield further information pertinent to answering research questions about local or regional prehistory under NRHP Criterion D. Therefore, the investigated portion of site 41LM50 in the APE is recommended as eligible for listing in the NRHP and for designation as an SAL. If this area cannot be avoided, then it is recommended the portion of site 41LM50 within the proposed easement of the low-water crossing of Lynch Creek, specifically the Late Prehistoric component in the top 30 cmbs, be targeted for mitigation excavation prior to any earth-disturbing activities.

Site 41LM51 is a buried campsite in Holocene alluvium on the southern side of Lynch Creek Bridge West. The proposed 10 m wide by 120 m long easement/APE for a low-water crossing spans two different terraces. Assessment was accomplished by mapping the proposed easement, hand-excavating 11 1-by-1 m test units (10.3 m<sup>3</sup>) within the easement, and mechanically excavating one trench in the existing right-of-way. Minimally three buried components were identified and sampled. Two separated, well-defined and well-stratified components, a Late Prehistoric/Protohistoric Toyah component overlying an Early Archaic Gower component, were in the low T<sub>0</sub> terrace. A third vertically and horizontally dispersed Late Archaic component,

between 10 and 90 cmbs was present in the higher T<sub>2</sub> alluvial terrace.

In the low T<sub>0</sub> terrace, the Toyah component, between 10 and 40 cmbs, yielded one complete Perdiz point, sparse lithic debitage, and scattered burned rocks. Two wood charcoal dates of 130 B.P. and 290 B.P., from a depth between 23 and 40 cmbs, document the probable age of this Toyah event. The Early Archaic Gower component was encountered between 80 and 110 cmbs, represented by one broken Gower point, a small burned rock dump feature (Feature 2), moderate frequencies of lithic debitage, and scattered burned rocks. Three *Rabdotus* shells from 80 to 90 cmbs yielded a combined radiocarbon date of ca. 6750 B.P. that provides an approximate age for this lower Gower component.

The higher T<sub>2</sub> terrace contains a greater density of cultural materials between 10 and 90 cmbs, however, in a less than ideal context. The component appears restricted to an estimated 1,500 years during the Late Archaic period, as evidenced by five Late Archaic projectile points of four typologies (i.e., Frio, Marcos, Lange, and Pedernales). Four radiocarbon dates on *Rabdotus* shells document a possible stable period in this high terrace towards the lower part of the cultural deposits. The youngest of the four dates is 4870 B.P., which came from 30 to 40 cmbs in Test Unit (TU) 5. Two other dates of 5220 B.P. and 5790 B.P. came from deeper in TU 5.

These three components at 41LM51 have the potential to yield further information pertinent to answering multiple research questions about local and regional prehistory under NRHP Criterion D. Therefore, the investigated portion of site 41LM51, within the APE/proposed temporary easement, is recommended as eligible for listing in the NRHP and for designation as SAL. If the APE cannot be avoided during bridge construction activities, then it is recommended that the portion of site 41LM51, specifically the Late Prehistoric Toyah and Early

Archaic Gower components in the low T<sub>0</sub> terrace, and the Late Archaic component in the higher T<sub>2</sub> terrace, be targeted for mitigation excavation prior to any earth-disturbing activities.

Following review of the interim report recommendations (Quigg and Frederick 2005), the Brownwood District engineers decided to avoid further impact to the prehistoric resources within the proposed easement at 41LM50 and 41LM51. Instead of using the temporary easement to allow continued flow of traffic, the roadway was closed to vehicle traffic, and bridge construction activities were performed within the existing right-of-way. This avoided additional impact, preserving these valuable cultural resources *in situ*.

The following report documents the 2004 National Register eligibility investigations and geoarcheological documentation conducted at prehistoric sites 41LM49, 41LM50 and 41LM51, reports the findings and analysis of the materials according to the TxDOT approved research design and protocols, and documents the site specific and component recommendations.

Additionally, the report also contains the results of an experimental study designed to test Shafer's (2006) suggestion that lithic debitage from latter stages of biface reduction, produced during manufacture of certain thin biface typologies could potentially be distinguishable in the archeological record. The manufacture of certain thin, relatively 'flat' bifaces, such as Gahagans, Shafer (2006) reasoned, would potentially have produced 'flatter' bifacial thinning flakes, or low flake curvature. If this were so, and those 'flat' flakes were distinctive enough to identify in the archeological record, this would potentially allow identification of production locales for Gahagan bifaces; and therefore, allow site association with the Prairie Caddo even in absence of diagnostic artifacts.

Although this original hypothesis was not supported by the data, the experiment was quite

informative. The analytical results suggested that correlation of flat bifacial thinning flakes to the production of flat, thin bifaces is not possible; and therefore, neither is correlation of bifacial thinning flake curvature with the production of certain biface typologies. The data indicates that typology is not a constraining factor upon the correlation between width and thickness, or the relative thickness of the finished biface, but instead the relative constraints

of the parent material and knapper technique. No correlation of the experimental replications was detected between the relative thinness of the finished biface (width-to-thickness ratio) and the flatness of the bifacial thinning flakes (length-to-height ratio) associated with the production of that biface. Therefore, bifacial thinning flake curvature cannot be utilized to identify prehistoric Gahagan biface production locales.

## **TABLE OF CONTENTS**

1.0	INTRODUCTION .....	1
1.1	Project Background.....	1
1.2	Project Location .....	2
1.3	Contents of Report .....	5
2.0	ENVIRONMENTAL BACKGROUND.....	7
2.1	Physiography and Hydrology .....	7
2.2	Geology and Soils.....	7
2.3	Climate.....	8
2.4	Flora and Fauna.....	8
3.0	CULTURAL BACKGROUND .....	11
3.1	Introduction.....	11
3.2	Archeological Background .....	11
3.3	The Early Archaic Period.....	13
3.3.1	Introduction.....	13
3.3.2	The Gower Point and Split Stem Series.....	16
3.4	The Middle Archaic Period in Central Texas .....	19
3.5	The Late Archaic Period in Central Texas.....	23
3.6	The Late Prehistoric Period in Central Texas .....	27
3.6.1	The Austin Interval .....	27
3.6.2	The Toyah Interval.....	28
3.6.3	Unassigned Late Prehistoric Components .....	33
4.0	METHODS .....	37
4.1	Introduction.....	37
4.2	General Field Methods.....	37
4.3	Laboratory Procedures and Technical Analyses.....	40
4.3.1	Analytical Methods.....	41
4.3.2	Flotation Methods .....	46
4.3.3	Technical Analyses .....	46
4.4	Curation.....	51
5.0	RESEARCH DESIGN FOR SITES 41LM50 AND 41LM51 .....	53
5.1	Introduction.....	53
5.2	Stratigraphy and Chronology .....	53
5.3	Feature Functions.....	53
5.4	Subsistence Patterns.....	53
5.5	Stone Tool Functions .....	53
5.6	The Question of the Sociocultural Identity.....	53

5.6.1	Late Prehistoric Cultural Identity and Shafer’s Prairie Caddo Model .....	54
5.6.2	Research Objectives .....	56
5.6.3	Procedures for the Experimental Study .....	57
5.6.4	Research Based on the Results of the Experimental Study .....	59
6.0	AN EXPERIMENTAL LITHIC ARTIFACT STUDY .....	63
6.1	Rationale for the Experimental Study .....	63
6.1.1	Addressing the Research Question: Process .....	65
6.2	Metric Analyses of Archeological Examples of Late Prehistoric Bifaces .....	66
6.2.1	Methods and Procedures: Archeological Sampling .....	66
6.2.2	Replicated and Archeological Specimen Range Comparisons .....	72
6.3	Analysis of the Experimental Debitage .....	73
6.3.1	Debitage Analysis: Methods Overview .....	75
6.3.2	Methodological Considerations and Discussions .....	76
6.3.3	Results of Experimental Debitage Analysis .....	78
6.4	Conclusions .....	86
6.5	Summary .....	89
7.0	GEOARCHEOLOGICAL EVALUATION .....	93
7.1	Introduction .....	93
7.2	Methods .....	93
7.3	Alluvial Stratigraphy .....	93
7.3.1	Late Quaternary Alluvial Deposits .....	93
7.4	Stratigraphic Summary .....	95
7.5	Geoarcheological Summary .....	97
8.0	TESTING RESULTS AT 41LM49 .....	99
8.1	Introduction .....	99
8.2	Site Specific Field Procedures .....	99
8.3	Geoarcheological Results .....	102
8.4	Cultural Features .....	102
8.4.1	Burned Rock Mound 1 .....	103
8.4.2	Feature 2 .....	106
8.5	Other Cultural Materials .....	109
8.6	Stratigraphy and Age of Burned Rock Mound 1 .....	110
8.6.1	Comments on the Contextual Integrity .....	111
8.7	Summary, Conclusions, and Discussion of 41LM49 .....	112
8.7.1	Summary .....	112
8.7.2	Conclusions and Discussions .....	112
8.8	Recommendations for 41LM49 .....	113

9.0	TESTING RESULTS AT 41LM50 .....	115
9.1	Introduction.....	115
9.2	Site Specific Procedures .....	115
9.3	Cultural Features.....	118
9.3.1	Feature 1.....	118
9.3.2	Feature 2.....	120
9.4	Material Classes and Frequencies.....	124
9.4.1	Lithic Debitage.....	124
9.4.2	Chipped Stone Tools.....	129
9.4.3	Vertebrate Faunal Remains.....	133
9.4.4	Mussel Shells .....	133
9.4.5	Charcoal .....	133
9.4.6	Ground Stone Tools .....	134
9.4.7	Snail Shells.....	135
9.4.8	Burned Rocks.....	135
9.5	Cultural Stratigraphy and Vertical Distribution of Artifacts .....	135
9.5.1	Geoarcheological Context.....	139
9.6	Summary, Conclusions, and Discussion.....	139
9.6.1	Summary .....	139
9.6.2	Conclusions and Discussion .....	140
9.7	Recommendations for 41LM50 .....	145
10.0	TESTING RESULTS AT 41LM51 .....	147
10.1	Introduction.....	147
10.2	Site Specific Procedures .....	148
10.3	Cultural Features.....	153
10.3.1	Feature 1.....	153
10.3.2	Feature 2.....	156
10.3.3	Feature 3.....	157
10.3.4	Feature 4.....	160
10.4	Material Classes And Frequencies.....	161
10.4.1	Lithic Debitage.....	161
10.4.2	Chipped Stone Tools.....	169
10.4.3	Faunal Remains.....	172
10.4.4	Mussel Shells .....	172
10.4.5	Charcoal .....	173
10.4.6	Ground Stone Tools .....	174
10.4.7	Snail Shells.....	174
10.4.8	Burned Rocks.....	175

10.5	Cultural Stratigraphy, Horizontal and Vertical Distributions of Artifacts.....	176
10.5.1	The Lower T <sub>0</sub> Terrace.....	176
10.5.2	High T <sub>2</sub> Terrace.....	179
10.5.3	Beveled Edge of Upper Terrace.....	184
10.6	Summary, Conclusions, and Discussion.....	184
10.6.1	Summary.....	184
10.6.2	Conclusions and Discussion.....	187
10.7	Recommendations for 41LM51.....	192
11.0	PROJECT SUMMARY AND RECOMMENDATIONS.....	193
11.1	Introduction.....	193
11.2	Project Summary.....	193
11.2.1	Site 41LM49 Summary.....	194
11.2.2	Site 41LM50 Summary.....	195
11.2.3	Site 41LM51 Summary.....	195
11.3	Project Recommendations.....	197
11.3.1	Site 41LM49 Recommendations.....	197
11.3.2	Site 41LM50 Recommendations.....	197
11.3.3	Site 41LM51 Recommendations.....	197
12.0	References Cited.....	199
13.0	Glossary of Technical Terms.....	219



## **LIST OF APPENDICES**

APPENDIX A: GEOMORPHOLOGICAL DESCRIPTIONS.....	229
APPENDIX B: RADIOCARBON ASSAY RESULTS .....	243
APPENDIX C: RESIDUE AND USE-WEAR ANALYSIS OF STONE ARTIFACTS .....	263
C.1    Introduction.....	265
C.2    Methods.....	265
C.3    Results.....	265
C.3.1    41LM50.....	265
C.3.2    41LM51.....	266
C.4    Discussion and Conclusions .....	267
C.5    References Cited .....	268
APPENDIX D: STARCH ANALYSIS OF SIXTY SAMPLES, .....	283
D.1    Introduction To Starch Grain Analyses .....	285
D.1.1    Understanding the Relationship between Residues and Artifacts .....	287
D.2    Methods.....	288
D.3    Results.....	289
D.3.1    Site 41LM49 .....	289
D.3.2    Site 41LM50 .....	289
D.3.3    Site 41LM51 .....	289
D.3.4    Starch Analysis of Artifacts Subjected to Use-Wear Analysis.....	290
D.4    Discussion And Conclusions .....	290
D.4.1    Damaged Starch Grains .....	290
D.4.2    Identifications and Plant Use at the Sites.....	290
D.5    References Cited .....	293
APPENDIX E: ASSESSMENT OF PHYTOLITH PRESERVATION AT 41LM51 .....	299
APPENDIX F: ENVIRONMENTAL BIOSILICA DATA 41LM50 AND 41LM51: .....	303
F.1    Summary.....	305
F.2    Overview.....	305
F.3    Background.....	305
F.4    Laboratory Phytolith Recovery Procedure .....	305
F.5    Data and Results .....	311
F.5.1    Sand.....	311
F.5.2    Phytoliths .....	318
F.6    Discussion.....	336
F.7    Conclusions.....	345
F.8    References.....	346

APPENDIX G: TXDOT CHIPPED STONE ANALYTICAL PROTOCOL.....	349
G.1 Txdot Archeological Studies Program.....	351
G.2 Taxonomy .....	351
G.3 Metric Information.....	353
G.4 Attributes.....	355
G.5 Wear Patterning .....	365
G.6 Raw Material.....	370
G.7 Projectile Point Data .....	371
G.8 Txdot Protocol for Debitage Analysis .....	373
G.9 References Cited.....	384
APPENDIX H: PLANT REMAINS FROM 41LM49, 41LM50, 41LM51 .....	389
H.1 Methods.....	391
H.2 Results and Conculsions .....	391
APPENDIX I: LITHIC DEBITAGE ANALYSES .....	393
I.1 Sites 41LM50 and 41LM51 .....	395
I.2 Experimental Lithic Analysis .....	395

## **LIST OF FIGURES**

Figure 1-1.	Project location in Lampasas County, Texas.....	3
Figure 1-2.	Project location in the biotic regions. ....	4
Figure 1-3.	View westward along FM 580W at the Lynch Creek Bridge East.....	5
Figure 2-1.	Overview of roadway crossing Lynch Creek.....	8
Figure 2-2.	View of dense Mexican cedar and various grasses as understory .....	9
Figure 3-1.	Prewitt’s (1981) Central Texas Archeological Region.....	12
Figure 3-2.	Central Texas chronology .....	13
Figure 3-3.	Selected Early Archaic sites in central Texas .....	15
Figure 3-4.	Selected Middle Archaic sites in central Texas .....	22
Figure 3-5.	Selected Late Archaic sites in central Texas.....	24
Figure 3-6.	Selected Late Prehistoric sites in central Texas .....	29
Figure 3-7.	Late Prehistoric arrow points from the McDonald site.....	34
Figure 4-1.	Example of trench excavation at sites.....	38
Figure 4-2.	Charles Frederick documenting soils in test unit profiles at 41LM51 .....	38
Figure 4-3.	Chipped stone artifact analysis flowchart. ....	42
Figure 4-4.	Dousman flotation system used to float sediment samples.....	46
Figure 4-5.	Examples of starch grains of wildrye grass recovered from burned rocks at an archeological site in Texas .....	49
Figure 5-1.	Map illustrating Shafer’s (2006) proposed Prairie Caddo habitats.....	55
Figure 5-2.	Gahagan biface illustration from Turner and Hester (1993:255).....	56
Figure 5-3.	Map showing a possible model of high-quality material distribution for Gahagan biface manufacture throughout east-central Texas among groups in the Late Prehistoric period.....	58
Figure 6-1.	Map illustrating Shafer’s (2006) proposed Prairie Caddo geographic areas. ....	64
Figure 6-2.	The 11 Gahagan bifaces from archeological context used in the present study. ....	67
Figure 6-3.	The 12 Friday bifaces from archeological context used in the present study. ....	68
Figure 6-4.	The 12 Harahey/four-beveled knives from archeological context used in the present study. ....	69
Figure 6-5.	Graphic presentation of the curated archeological Gahagan, Friday, and Harahey bifaces compared to the six replicated specimens. ....	73
Figure 6-6.	Replications of three Late Prehistoric biface types made by TxDOT archeologist, Chris Ringstaff .....	74
Figure 6-7.	Distributional groupings of width and thickness variables for archeological specimens by biface type. ....	75
Figure 6-8.	Idealized profile of a bifacial thinning flake and the axes along which the length and the arc height of the flake were measured. ....	78
Figure 6-9.	Size grade sorting by percentage for experimental bifaces (both individual and overall average) compared to debitage recovered from 41LM50.....	79
Figure 6-10.	Dorsal cortex groupings for the six replicated bifaces.....	79
Figure 6-11.	Bar graph showing percentages of each platform type present for the six replicated bifaces and their average compared to debitage from 41LM50.....	82
Figure 6-12.	Graph showing the range of arc height-to-flake length ratios of bifacial	

	thinning flakes from each of the six replicated bifaces.....	82
Figure 6-13.	Relative flake flatness (L:H ratios) of bifacial thinning flakes. ....	85
Figure 6-14.	Graph showing the lack of correlation between biface W:T ratios (relative finished biface thickness) and average of flake L:H ratios (relative flatness of associated bifacial thinning flakes) for experimental replicated bifaces. ....	85
Figure 6-15.	Comparative plot of biface W:T ratio ranges of archeological samples sorted by biface typologies (trendlines and experimental bifaces are included for comparative purposes).....	87
Figure 6-16.	Plot of relative biface thickness compared to maximum biface thickness variable.....	87
Figure 7-1.	Alluvial stratigraphy and cultural strata at 41LM49, 41LM50, and 41LM51 .....	94
Figure 7-2.	Photograph of the Unit 1 gravel lag on a limestone bedrock surface upslope of Unit 2, east of 41LM5 .....	95
Figure 7-3.	Drawing of the southwestern wall of Trench 1, 41LM49, showing lateral accretion sets of Unit 5a, and primarily vertical accretion deposits of Unit 5b.....	96
Figure 7-4.	Photograph of southwestern wall of Trench 1, 41LM49, showing lateral accretion sets of Unit 5a, and primarily vertical accretion deposits of Unit 5b.....	96
Figure 8-1.	Skematic sketch map of site 41LM49 and locational relationship with 41LM50 .....	100
Figure 8-2.	Sketch map of the portion of site 41LM49 on the northern side of FM 580W. ....	101
Figure 8-3.	Eastern edge of existing right-of-way showing steeply sloping, eroding deposits of BRM 1 exposed beneath the existing fence at 41LM49.....	104
Figure 8-4.	Close-up of eroding burned rocks in BRM 1 under fence at 41LM49 .....	104
Figure 8-5.	Top section of the central part of BRM 1 following vertical exposure by trenching at 41LM49 .....	105
Figure 8-6.	Close-up photograph of deep pit(s) exposed in profile of BRM 1, 41LM49.....	106
Figure 8-7.	Profile drawing of Burned Rock Mound 1 at 41LM49.....	107
Figure 8-8.	Photograph of Feature 2, a burned rock hearth in southwestern wall of Trench 1 south of the roadway, 41LM49 .....	109
Figure 8-9.	Untyped projectile point (#2-10) from profile window on eastern side of BRM 1. ....	110
Figure 8-10.	Ground face with peck marks near middle and beveled edge of complete mano (#2-11).....	110
Figure 9-1.	Plan sketch map of site 41LM50 that shows the investigated areas in the temporary proposed easement on west side of the current right-of-way. ....	116
Figure 9-2.	View east of proposed easement and east end of terrace with excavation units in progress at 41LM50.....	117
Figure 9-3.	Photograph of hard dense clays in Trench 2 wall profile at 41LM50, view east.....	118
Figure 9-4.	Feature 1 burned rock distribution in southwestern quadrant of TU 2 at 41LM50 .....	118
Figure 9-5.	Plan view drawing of burned rocks in TUs 2 and 8 as part of Feature 1 at 41LM50. ....	119
Figure 9-6.	Feature 2 burned rocks following exposure with backhoe. ....	121
Figure 9-7.	Plan view of Feature 2 that depicts distribution of burned rocks in backhoe scrape at 41LM50.....	122
Figure 9-8.	Vertical patterning of plotted materials of Feature 2 in Trench 2 at 41LM50.....	123
Figure 9-9.	Frequency by level for analyzed lithic debitage from 41LM50.....	125
Figure 9-10.	Sample of igneous/fossiliferous rock in archeological assemblage from 41LM50.....	126
Figure 9-11.	Sample of quartzite debitage in the archeological assemblage from 41LM50.....	126

Figure 9-12.	Size grade distribution of analyzed lithic debitage from Levels 1 through 3 at 41LM50. ....	127
Figure 9-13.	Distribution of platform-bearing flakes exhibiting thermal alteration. ....	127
Figure 9-14.	Frequency of platform types in the analyzed assemblage. ....	127
Figure 9-15.	Cortex present on analyzed platform-bearing lithic debitage from 41LM50. ....	128
Figure 9-16.	Arrow points; Bonham (#68-10), unwashed Alba (#60-10), and untyped (#1-10). ....	129
Figure 9-17.	Pedernales (#9-10) & Marcos (#60-11) dart point fragments; untyped blade (#76-10). ....	130
Figure 9-18.	Close-up of unwashed uniface (#18-11) and unwashed distal end of broken side scraper (#26-10). ....	131
Figure 9-19.	Large biface (#66-10) from lower questionable component. ....	132
Figure 9-20.	Graver (#71-12) with worked tip (top left of picture). ....	132
Figure 9-21.	Edge-modified flakes (#35-10 and #35-11) that yielded starch grains. chert. Eight specimens reveal patterned scarred edges at relatively steep angles to indicate a likely scraping motion. ....	132
Figure 9-22.	Top view of broken metate (#27-10). ....	134
Figure 9-23.	South wall profile of TU 7 that reveal cultural rocks in clay loam sediments. ....	135
Figure 9-24.	Vertical patterning of plotted materials in TUs 2 and 8 at 41LM50. ....	137
Figure 9-25.	Vertical patterning of plotted materials in TUs 4 and 5 at 41LM50. ....	137
Figure 9-26.	Vertical patterning of plotted materials in TUs 7 and 9 at 41LM50. ....	138
Figure 9-27.	Prewitt's (1995:89) distribution map of the Alba points in Texas. ....	141
Figure 9-28.	Prewitt's (1995:93) distribution map of the Bonham points in Texas. ....	141
Figure 9-29.	"Toyah Focus" arrow point types. ....	142
Figure 10-1.	View east of proposed easement on south side of roadway with Lynch Creek in foreground, and western end of site 41LM51 with completed TU 4 in cutbank. ....	147
Figure 10-2.	View of tree covered upper T <sub>2</sub> terrace surface along proposed easement across 41LM51. ....	148
Figure 10-3.	Holocene alluvial deposits in vertical cutbank on east edge of Lynch Creek with completed TU 4 at 41LM51. ....	149
Figure 10-4.	Plan sketch map of site 41LM51 indicating investigated areas in the temporary proposed easement on the south side of the current right-of-way. ....	150
Figure 10-5.	Profile of alluvial deposits exposed in TU 2 in low T <sub>0</sub> terrace, 41LM51. ....	152
Figure 10-6.	Profiling north wall of TU 10 at 41LM51. ....	153
Figure 10-7.	Profile of Feature 1 on southern side of Trench 1 with TU 3 in background at 41LM51. ....	154
Figure 10-8.	Plan view and profile drawing of Feature 1 at 41LM51. ....	155
Figure 10-9.	Plan view drawing of Feature 2 at 41LM51. ....	156
Figure 10-10.	Plan view drawing of Features 3 and 4 at 41LM51. ....	158
Figure 10-11.	Top view of exposed burned rocks in Feature 3 (top) and Feature 4 (bottom) in TU 10, 41LM51. ....	158
Figure 10-12.	Profile of north wall of TU 10 with part of Feature 3 extending into wall, 41LM51. ....	159
Figure 10-13.	Frequency for lithic debitage from Toyah component, TUs 1 and 2, Levels 3 to 4 (20-40 cmbs). ....	164

Figure 10-14.	Size distribution of Toyah component lithic debitage. ....	164
Figure 10-15.	Frequency for lithic debitage from 41LM51 Gower component in TUs 1 and 2, Levels 9, through 11 (80 to 110 cmbs). ....	164
Figure 10-16.	Size grade frequency distribution of Gower component lithic debitage at 41LM51.....	164
Figure 10-17.	Platform types in 41LM51 Gower component debitage assemblage.....	166
Figure 10-18.	Frequency for Late Archaic sample of debitage from 41LM51, TUs 5 and 10, Levels 5 and 6 (40 to 60 cmbs). ....	166
Figure 10-19.	Size distribution of Late Archaic component lithic debitage sample at 41LM51.....	167
Figure 10-20.	Frequency of platform types in the sampled Late Archaic component debitage at 41LM51.....	168
Figure 10-21.	Cortex on Late Archaic platform-bearing debitage sampled from 41LM51. ....	168
Figure 10-22.	Unwashed Perdiz (#13-10, left) and Gower (#19-10, right) point from low T <sub>0</sub> terrace at 41LM51. ....	170
Figure 10-23.	From left to right, unwashed Frio (#104-10), unwashed Marcos (#52-10), and unwashed Lange (#89-10) dart points from upper T <sub>2</sub> terrace at 41LM51.....	170
Figure 10-24.	Dart point bases from upper T <sub>2</sub> terrace at 41LM51, unwashed and untyped (#52-11 and #69-10) and unwashed Pedernales base (#79-10).....	170
Figure 10-25.	Unwashed biface fragments from Late Archaic component in T <sub>2</sub> terrace at 41LM51 (#81-10, #91-10 and #59-10) used in starch grain analysis. ....	171
Figure 10-26.	Unwashed gouge (#83-10) and unwashed side scraper (#66-10) from upper T <sub>2</sub> terrace at 41LM51. ....	171
Figure 10-27.	Unwashed mano (#59-11) from 24 cmbs in TU 6 at 41LM51. ....	174
Figure 10-28.	Vertical patterning of in situ plotted materials in TUs 1 and 2 at 41LM51. ....	177
Figure 10-29.	Vertical patterning of in situ plotted materials in TUs 5 and 10 at 41LM51. ....	179
Figure 10-30.	Vertical distribution of lithic debitage and burned rocks by selected test units at 41LM51.....	180
Figure 10-31.	Photograph facing east from near Lynch Creek Bridge West, at 41LM51.....	182
Figure 10-32.	Small section of the Gorman Falls NE DOQQ image of 41LM51 (top panel); line drawing made from aerial illustrating geomorphic relationships (bottom panel)....	183
Figure C-1.	Visual summary of results from 41LM50.....	273
Figure C-2.	Visual summary of results from 41LM50.....	274
Figure C-3.	Site 41LM50, #17-11.....	275
Figure C-4.	Site 41LM50, #12-10.....	276
Figure C-5.	Summary of results from 41LM51. ....	277
Figure C-6.	Summary of results from 41LM51.....	278
Figure C-7.	Summary of results from 41LM51. ....	279
Figure C-8.	Site 41LM51, #85-13.....	280
Figure C-9.	Site 41LM51, #70-10.....	281
Figure D-1.	Starch remains recovered from the analyzed samples. ....	291
Figure F-1.	Soil samples prior to detergent addition and disaggregation to separate particle sizes. The lab sample number abbreviations of #1-10 are identified in Table F-1 (right hand column).....	307
Figure F-2.	Samples in Calgon® solution on mechanical reciprocal shaker.....	307

Figure F-3.	Disaggregated sample solutions upon removal from the mechanical shaker. The clay (and some silt) is still suspended while the sand fractions have already settled. ....	307
Figure F-4.	The lower portion of the two settled control samples (157-004 and 41-004). ....	308
Figure F-5.	Decanted sample solutions containing silt and clay after decanting from the sand fraction. ....	308
Figure F-6.	The suspended clay fraction from Sample 6 in Figure F-5A. ....	309
Figure F-7.	Settled silt after final clay removal. ....	310
Figure F-8.	Isolated phytolith fractions. ....	310
Figure F-9.	Isolated sand fractions following oven drying (samples jars are about 2 inches in diameter) ....	312
Figure F-10.	Fossil sponge spicules and other fossils in the sample sand fractions (41LM50). ....	313
Figure F-11.	Fossil sponge spicules in the 41LM51 sample sand fractions. ....	314
Figure F-12.	Snails from 41LM51; Sample 102-004 (images A-M). Two views of A are shown. ....	314
Figure F-13.	Snails from 41LM51. Samples 103-004 (images A-C), 102-004 (image D), and 108-004 (image E (two views), F- N). Specimens D and K appear to be fragments of shells or large snails. ....	315
Figure F-14.	Snails from 41LM51. Samples 117-004 (images A-E), 132-003 (images F-N), and 157-004 (images O-U (two views each of specimens Q and R). ....	316
Figure F-15.	Unidentified specimens (41LM51). Samples 102-004 (images A-B) and 117-004 (images C- D). ....	317
Figure F-16.	Flake debris in the sand samples (41LM51). A-C Sample 103-004, and D sample 108-004. ....	317
Figure F-17.	Carbonates in 41LM51. ....	318
Figure F-18.	Carbonate confirmation (HCl reaction). ....	320
Figure F-19.	Examples of short cell phytolith form specimens recovered at 41LM50 and 41LM51. ....	321
Figure F-20.	Cucurbit phytoliths from 41LM50 and 41LM51. ....	328
Figure F-21.	Possible cucurbit phytoliths from 41LM50 and 41LM51. ....	328
Figure F-22.	Small Panicoid cross phytoliths from 41LM50 and 41LM51. ....	329
Figure F-23.	Medium Panicoid cross phytoliths from 41LM50 and 41LM51. ....	329
Figure F-24.	Burned Panicoid cross phytoliths from 41LM50 and 41LM51. ....	330
Figure F-25.	Commelinaceae seed coat fragment (sample 104-04). ....	330
Figure F-26.	Freshwater sponge spicules, gemmoscleres, and similar particles from 41LM51. ....	331
Figure F-27.	Heavily weathered bulliform and elongate phytoliths. ....	332
Figure F-28.	Representative good condition bulliform phytoliths. ....	333
Figure F-29.	Tree phytoliths. ....	334
Figure F-30.	Large unidentified plant phytoliths. ....	335
Figure F-31.	Short cell environmental signatures of the five samples collected for environmental assessment. ....	339
Figure F-32.	Short cell feature and environmental signatures. ....	341
Figure F-33.	Burned short cell phytolith incidence (percent of total short cells counted) by sample depth. ....	342
Figure F-34.	Total tree phytoliths by depth. ....	342



Figure F-35.	Incidence of charcoal particles in the soil samples (total particles counted in microscopic fields scanned).....	342
Figure F-36.	Log plot of burned particles and tree phytolith ratios.....	343
Figure F-37.	Chloridoid short cell phytolith data. ....	344
Figure G-1.	Artifact taxonomy for chipped stone tools based on technological attributes and reduction characteristics.....	353
Figure G-2.	Artifact taxonomy for chipped stone objects with primarily non-utilitarian, symbolic purpose.....	354
Figure G-3.	Taxonomy for chipped stone cores.....	354
Figure G-4.	Metric measurements recorded directly from tool.....	355
Figure G-5.	Edge angle can be recorded with the use of a goniometer.....	355
Figure G-6.	In the illustration above, "retouched" and "fractured segments" are generally represented by Stage 5 (rejuvenated forms).....	358
Figure G-7.	Give stages of Chipped Stone Analytical Protocol.....	358
Figure G-8.	Chipped stone tools are more often discovered in a broken state.....	359
Figure G-9.	These terminations are often observed on bifacial blanks and preforms that were discarded in the process of manufacture. ....	361
Figure G-10.	These terminations illustrate additional failures that may render the objective piece unusable or incapable of further reduction and recycling.....	362
Figure G-11.	Edge morphology has its greatest utility in characterizing projectile points, darts, and knives.....	363
Figure G-12.	Patterns of flake removal in edge construction, potentially related to flaking technique, tool function, aesthetic display, and social identity. ....	364
Figure G-13.	Examples of lateral edge flaking attrition. (A) bifacial-unilateral; (B) unifacial-unilateral; (C) Platform abrasion and (likely) post-depositional removals.....	366
Figure G-14.	Patterns of polish formation and distribution related to use-wear. ....	368
Figure G-15.	Development of lateral scars (or striations) developed on the working edge of the tool derived from abrasive and repeated contact between the tool form and contact material. ....	369
Figure G-16.	The graphic above illustrates both a quantifiable and a qualitative means by which to measure or estimate the amount of remnant dorsal cortex on a lithic flake. ....	376
Figure G-17.	10-20x magnification (hand lens or loop) is recommended for viewing platforms on debitage in the ¼ -½ inch size grades.....	378

## LIST OF TABLES

Table 6-1.	Metric Data (in mm) of 35 Late Prehistoric Bifaces in TARL Collections Compared to Experimental Replicated Bifaces. ....	70
Table 6-2.	Characteristics of Six Replicated Bifaces Made by C. Ringstaff of TxDOT.....	72
Table 6-3.	Quantities of Cortex Groupings for Debitage from the Production of the Six Replicated Bifaces.....	80
Table 6-4.	Platform Types for Debitage from the Production of the Six Replicated Bifaces. ....	81
Table 6-5.	Metric Data (in mm) on Whole Bifacial Thinning Flakes from Production of Six Replicated Bifaces.....	83
Table 6-6.	T-Test Results for Comparison of Experimental Specimens Gahagan #12 and Harahey #3 .....	84
Table 6-7.	Results of T-tests for W:T of Archeological Biface Samples by Types (t-tests are two-tailed, two-sample, assuming unequal variances).....	88
Table 8-1.	Radiocarbon Data and Results from 41LM49. ....	111
Table 9-1.	Radiocarbon Data and Results from 41LM50. ....	124
Table 9-2.	Material Summary for 41LM50.....	124
Table 9-3.	Vertical and Horizontal Distribution of Burned Rocks at 41LM50.....	136
Table 9-4.	Vertical and Horizontal Distribution of Lithic Debitage at 41LM50 .....	136
Table 10-1.	Vertical and Horizontal Distribution of Lithic Debitage by Physiographic Setting. ....	162
Table 10-2.	Material Summary by Test Unit for 41LM51 .....	173
Table 10-3.	Vertical and Horizontal Distribution of Burned Rocks at 41LM51.....	175
Table 10-4.	Radiocarbon Data and Results from 41LM51 .....	178
Table A-1.	Mechanical Trench Descriptions at 41LM49.....	231
Table A-2.	Mechanical Trench Descriptions at 41LM50.....	235
Table A-3.	Mechanical Trench and Unit Descriptions at 41LM51.....	237
Table C-1.	Results for 41LM50. ....	271
Table C-2.	Results for 41LM51 .....	272
Table D-1.	Starch Remains Recovered from the Analyzed Samples.....	296
Table E-1.	Samples Used in Phytolith Analysis .....	301
Table F-1.	Lampasas County Site's Soil Samples Identities .....	306
Table F-2.	Raw Phytolith Counts and Short Cell Normalized Percent. ....	322
Table F-3.	Burned Short Cell Phytolith Counts .....	324
Table F-4.	Burned: Total Short Cell Phytolith Counts (Normalized) .....	325
Table F-5.	Summary of Major Particle Forms Observed .....	326
Table F-6.	Ratios of Short Cell Phytolith Forms and Burned Particles.....	327
Table F-7.	Soil Texture Data.....	327
Table G-1.	Example of Tool Observations and Measurements .....	372
Table H-1.	Identified Plant Material .....	392
Table I-1.	Summary of Lithic Debitage for 41LM50.....	396
Table I-2.	Summary of Lithic Debitage for 41LM51 .....	396
Table I-3.	Summary of Lithic Analysis for Experimental Biface Study .....	397

*This page intentionally left blank.*

## **ACKNOWLEDGEMENTS**

Many individuals and institutions assisted the authors in completing this project. We would like to thank all participants for their various contributions, regardless how large or small it may appear to others, as each and every part was necessary to complete this report.

This project was under the direction of the Environmental (ENV) Affairs Division of the Texas Department of Transportation (TxDOT) and various individuals helped guide and direct this effort. We thank the many TxDOT personnel for their support and guidance over the 10 years. At project initiation, Dr. Nancy A. Kenmotsu was the Director of the Cultural Resource Management, with Dr. Owen Lindauer as Supervisor of the Archeological Studies Program, followed by Dr. G. Lain Ellis, and presently the current Supervisor Dr. Scott Pletka, who has guided this program to the end. Mr. Allen Bettis, the former TxDOT Brownwood District archeologist, was responsible for this region during the fieldwork, conducted the initial site inspection, the background file search, wrote various work authorizations, and, along with Dr. Mary Jo Galindo and Mike Quigg from TRC Environmental Corporation (TRC), participated in the May 2004 field inspection. Mr. Bettis completed both Archeological Impact Evaluation forms for the two bridges and recommended the eligibility assessment at these three sites. He provided numerous project maps and copies of photographs from his initial visits to the project area. He also facilitated the initial work authorization for the final analyses and reporting phases, which was eventually placed on hold after completing 4 of 14 tasks. Mr. Bettis worked with TRC personnel through mid-2009 and also reviewed the draft report. Thank you Allen, for your continued support and answering our many questions throughout the duration of this project.

Dr. Jim Abbott and other TxDOT representatives participated in devising field strategies for this archeological evaluation and testing program. Dr. Abbott also reviewed multiple requests for dating radiocarbon samples and facilitated the handling of samples to the radiocarbon laboratories. TxDOT Brownwood District office provided the backhoe and operator, Mr. Bill Henderson, for the mechanical excavations and backfilling. Thank you Mr. Henderson for your precise and careful digging. Mr. Andrew Chisholm, the Environmental Specialist in the Design Section of the Brownwood District was also very helpful in facilitating the fieldwork. Other Brownwood District personnel, Tom Dahl and Mike Ray, stopped by during the fieldwork and expressed interest in the investigations.

Dr. Jason Barrett took over for Allen Bettis in July 2009, as the TxDOT archeologist in charge of this project and was directly involved in the planning and reviewing the experimental analysis, writing much of the research design for the experimental lithic debitage analysis, and individual deliverable reviews, project review, and facilitated the various work authorizations and supplementals during the final analyses and reporting phases. Drs. Barrett and Abbott along with Allen Bettis provided review comments on the draft and final technical report. Thank you Jason for your help and guidance in these final steps.

Noted flint knapping specialist and TxDOT archeologist Chris Ringstaff manufactured multiple fine biface replications of three different biface typologies, and submitted all the resulting debitage, for our use in the experimental analysis. Thank you Chris, for your excellent reproductions of the three types used in this analysis for comparison with the archeological specimens.

The TRC field archeologists are thanked for their hard work and dedication to the various tasks at hand in retrieving the necessary data in a timely and precise manner. The crew included Billy Turner,

Charles Burton, Greg Sundborg and crew chief Mercedes Cody, under the field direction of Mike Quigg. Mr. Turner constructed the site sketch map for 41LM50. Dr. Charles Frederick, project geoarcheologist, is thanked for his thorough understanding and documentation of the geoarcheological aspects of each of these sites and his comments and directions to the archeologists during the fieldwork. Dr. Frederick helped significantly in documenting the burned rock midden profile at 41LM49 with advice, a series of digital pictures, the writing of Chapter 7.0, and production of all the geoarcheological figures used in this report. He also collected the natural rock samples from the lag gravel source exposed in the vicinity of site 41LM51, to be used in the anticipated instrumental neutron activation analysis.

In the TRC Austin laboratory, former Laboratory Director Mercedes Cody initially processed the artifacts, created and maintained the electronic database, and managed the paper records throughout the interim report process. Ms. Cody also produced most figures used in the interim report. Her diverse skills and organization aided in the successful completion of the interim report. Subsequently, during the final data analysis and reporting phase, Trisha-Ann Gonzales conducted numerous laboratory tasks. She helped in the preparation and documentation of the many samples sent for technical analyses, maintained and updated the database, performed artifact and debitage analyses under the direction of Paul Matchen, and also prepared the materials and documents for curation. Shannon Gray, current Laboratory Director, helped with data verification, database management, finalized the drawings and tables used in the final report, and helped write, finalize, and proof Chapter 6.0. She also performed most editing and proofreading tasks for the report.

Dr. Robert Ricklis and Paul Matchen contributed significantly to the final research design, in both

interpretation of the findings, and writing the final chapters. Dr. Ricklis finalized the research design provided in Chapter 5.0, conducted the analyses on both the archeological bifaces curated at Texas Archeological Research Laboratory as well as the experimental bifaces and lithic debitage produced by TxDOT archeologist Chris Ringstaff. Dr. Ricklis and Shannon Gray wrote Chapter 6.0 on the experimental analyses and results. Mr. Matchen wrote the environmental background chapter, contributed to drafts of the research designs, participated in the analyses of the stone tools and lithic debitage with the assistance of Trisha-Ann Gonzales, and wrote sections pertaining to the lithic tools and debitage. Barrett Clark, biologist for TRC, conducted the mussel shell identifications and is thanked for his knowledge and expertise. Marissa Stewart, Chantel Pham, and Ashleigh Knapp formatted the drafts and final report, and oversaw the production of the final document.

A number of individuals and institutions also supported this project by conducting highly specialized technical analyses on selected samples. Laura Nightengale, former Head of Collections at Texas Archeological Research Laboratory, contributed her time and knowledge in the selection of the archeological bifaces from the collections to be used in the comparative analysis. Her help with facilitating our analyses of those specimens is much appreciated. Dr. Leslie Bush, Austin archeobotanist, was kind enough to assess one light fraction flotation sample and provide her professional comments regarding the value of further detailed analyses of other light fraction samples. Thank you Leslie for your professionalism and comments. Dr. Phil Dering, of Shumla Archeobotanical Services in Comstock, Texas, conducted the macrobotanical identification of the charcoal and plant remains, and wrote Appendix H. Dr. Steven Bozarth, of Lawrence, Kansas, assessed the presence/absence of phytolith samples in the sediments and wrote Appendix E. Dr. Linda Perry, Executive Director of The Foundation for

Archaeobotanical Research in Microfossils, conducted the starch grain analysis and wrote Appendix D. Dr. Byron Sudbury, at J. S. Enterprises in Oklahoma, conducted the detailed phytolith analysis and wrote Appendix F. Dr. Bruce Hardy, professor in the Department of Anthropology at Kenyon College in Ohio, is also thanked for his expertise in conducting the high-powered microscopic use-wear analyses on the chipped stone tools. The technical staff at Beta Analytic Inc. in Florida, and at the University of Georgia, Center for Applied Isotope Studies in

Georgia, is thanked for their expertise in handling the samples for radiocarbon dating. We thank these highly skilled individuals and institutions for their professionalism and willingness to conduct analyses for this project. Their collective knowledge made significant contributions to furthering our understanding of Texas prehistory, and they are thanked for their efforts.

Mike Quigg  
Project Manager

*This page intentionally left blank.*



## **1.0 INTRODUCTION**

J. Michael Quigg

### **1.1 PROJECT BACKGROUND**

This technical report describes the results of the archeological eligibility testing program implemented at three previously unrecorded prehistoric sites (41LM49, 41LM50, and 41LM51). The Brownwood District office of the Texas Department of Transportation (TxDOT) proposed to replace two existing bridge structures along Farm to Market Road 580W (FM 580W), project CSJ: 0231-15-032, crossing over Lynch Creek twice (designated as east and west). The two bridges are about 1.6 kilometer (km) apart in southwestern Lampasas County, Texas.

Initially, the planned bridge replacement projects called for the implementation of temporary low-water crossings in temporary easements, the areas of potential effect (APE) on private property on the southern sides of the two current bridges. Portions of these prehistoric sites are partially within the existing right-of-way and/or in the proposed temporary easements/APEs.

The required archeological fieldwork was conducted in August 2004 to evaluate each archeological site for its eligibility for listing on the National Register of Historic Places (NRHP) per the requirements of Section 106 of the National Historic Preservation Act (NHPA), the implementing regulations of 36CRF Part 800, and for designation as a State Antiquities Landmark (SAL) under the Antiquities Code of Texas (Texas Natural Resource Code, Title 9, Chapter 191 as amended). This required assessment was conducted by archeologists from the Cultural Resources Section of Planning, Permitting and Licensing Practice of TRC Environmental Corporation's (TRC) Austin office under TxDOT Scientific Services Contract No. 573XXSA006 (Work

Authorization No. 57315SA006). Subsequent analyses and reporting phases were conducted under multiple TxDOT contracts and work authorizations over the years since the 2004 eligibility testing investigations. All fieldwork, analyses, subsequent reporting, and curation were under Texas Antiquities Committee (TAC) Permit No. 3494 issued by the Texas Historical Commission (THC) to Principal Investigator J. Michael Quigg prior to initiating the fieldwork.

Andrew Chisholm, Brownwood District Environmental Coordinator, notified the Archeological Studies Program archeologist at the TxDOT Austin office of their intent to replace four bridge-class structures on FM 580W west of Lampasas, Texas. The four bridges crossed small creek drainages from west to east; McAnelly Creek, Lynch Creek Bridge West, Lynch Creek Bridge East, and Browns Creek. The existing bridges would be replaced with new structures that would widen each bridge width by approximately 3.6 meters (m), 1.8 m on each side. Former TxDOT Brownwood District archeologist Allen Bettis made the initial assessment of these four crossing during a field visit in February 2004. He observed cultural materials in at least three of the eight quadrants at two bridge locations, Lynch Creek Bridge West and Lynch Creek Bridge East. The remaining two crossings at McAnelly Creek and Browns Creek had no potential for intact, significant cultural deposits (Bettis personal communication).

Further inspection of the APEs by Mr. Bettis, TxDOT archeologist Dr. Mary Jo Galindo, and TRC archeologist Mike Quigg in May 2004 reaffirmed the presence of cultural resource materials in three quadrants within the existing right-of-way and/or proposed easements at both Lynch Creek Bridges, East and West crossings. Mr. Bettis conducted a review of the Texas Archeological Sites Atlas in June 2004 and found that no previously recorded sites within, adjacent,

or near the proposed APE (Bettis personal communication). Mr. Bettis completed Archeological Impact Evaluation forms for the Lynch Creek East and West structures and recommended that eligibility testing be conducted at 41LM49, 41LM50, and 41LM51. THC subsequently concurred with TxDOT recommendations.

Prehistoric sites 41LM49 and 41LM50 are on the northern and southern sides respectively of the Lynch Creek Bridge East, whereas site 41LM51 is at the southeastern corner of the Lynch Creek Bridge West. Construction activities within the proposed temporary easements/APE slated for the southern side of the current roadway would primarily impact undisturbed areas of sites 41LM50 and 41LM51. No new impacts were planned for site 41LM49, a burned rock mound site previously impacted by FM 580W road construction. Consequently, investigations at 41LM49 were confined to the existing right-of-way and focused on profiling, sampling, and documenting a partially disturbed BRM along and under the northern edge of the right-of-way fence line. This documentation was accomplished through a mechanically dug trench that created a profile of the BRM, plus the excavation of two mechanical trenches that totaled 12 linear m and a single 1-by-1 m test unit on the southern side of the existing road. At 41LM50, the proposed easement crossed a narrow, single alluvial terrace that contains buried cultural remains. Two mechanically dug trenches that encompassed 23 linear meters and nine 1-by-1 m hand-excavated test units (6.5 cubic meters [m<sup>3</sup>]) sampled the APE.

At 41LM51, the proposed easement crossed two adjoining alluvial terraces and the narrow sloping area between the two terraces. One mechanical trench (16 linear meters) in the existing right-of-way and 11 1-by-1 m test units were excavated across the various landforms in the proposed temporary easement. In total, the archeological investigations at the three sites included the

excavation of five mechanical trenches that totaled 51 linear meters, and hand-excavation of 21 1-by-1 m test units that encompassed 17.2 m<sup>3</sup>, profiling some 17+ meters of BRM, plus the geoarcheological documentation of the Holocene alluvial deposits.

Following the TRC fieldwork and preliminary assessment of the recovered data from the three prehistoric sites, TRC recommended that sites 41LM50 and 41LM51 were eligible for listing on the NRHP under Criterion D and for designation as SALs, and that mitigation through data recovery be conducted at these two sites if they could not be avoided during construction activities (Quigg and Frederick 2005). TRC did not recommend further work at 41LM49 as it did not contain sufficient data to warrant listing on the NRHP or as an SAL. Following the concurrence by THC that sites 41LM50 and 41LM51 were eligible for listing on the NRHP and designation as SALs, the Brownwood District office determined that the two sites could be avoided by closing FM 580W and restricting construction activities to the existing right-of-way. Subsequently the construction project was let in July 2005 and completed in February 2006. Prehistoric sites 41LM50 and 41LM51 were avoided during bridge replacement activities and those parts of these two sites within the proposed APE were preserved in place.

## 1.2 PROJECT LOCATION

This bridge replacement project lies in central Texas, roughly 17 kilometers (km) west of Lampasas in western Lampasas County and just east of the Colorado River (Figures 1-1 and 1-2). Lampasas County lies just south of the southeastern end of the Rolling Plains in the Edwards Plateau with the Llano Uplift west of the Colorado River and the Blackland Prairie to the east. The surrounding environment is rural and the terrain exhibits undulating relief (Figure 1-3). Vegetation cover consists of scattered oak (*Quercus* sp.), pecan (*Carya* sp.), Ashe juniper (*Juniperus ashei*),

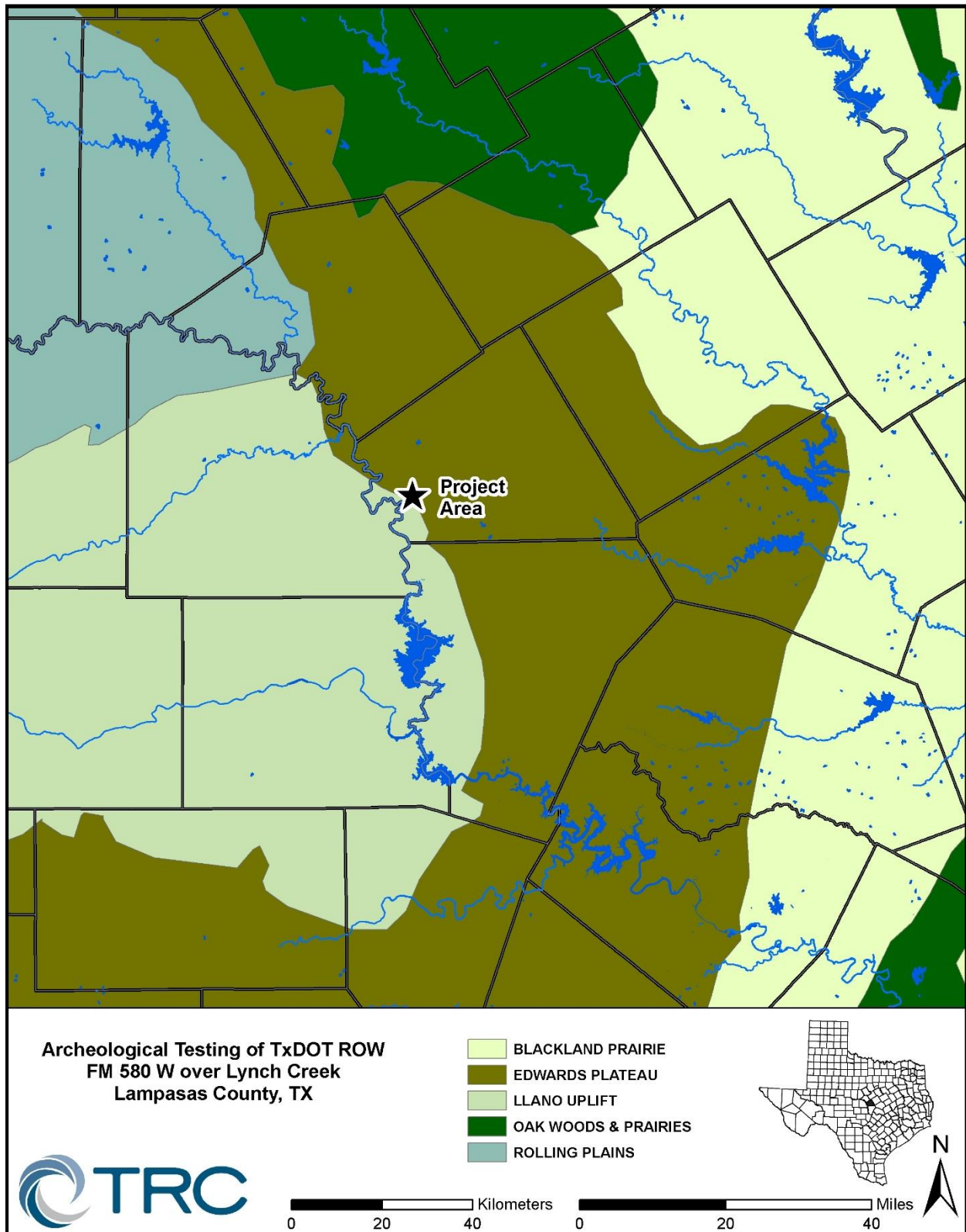


Figure 1-1. Project location in Lampasas County, Texas.

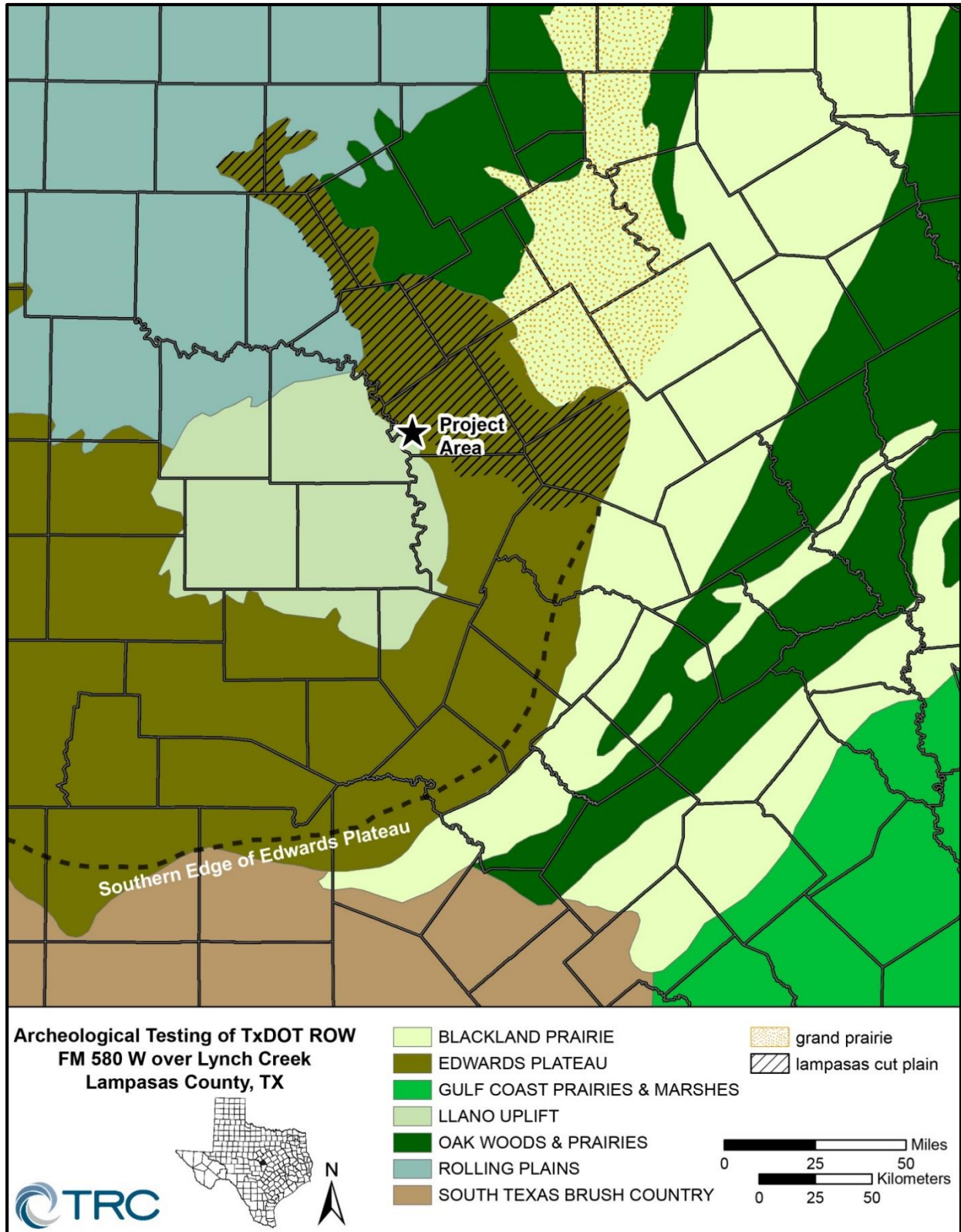


Figure 1-2. Project location in the biotic regions.



**Figure 1-3. View westward along FM 580W at the Lynch Creek Bridge East** (Photograph by Allen Bettis, February 2004). Note: The site 41LM49 is on high terrace on the right side, whereas 41LM50 is on the low terrace on the opposite side of the creek.

Texas persimmon (*Diospyros texana*) trees, and various grass species.

### **1.3 CONTENTS OF REPORT**

Following this introductory chapter, Chapter 2.0 presents an overview of the modern environmental setting and regional paleoclimate at the projected time represented at these prehistoric occupations. Chapter 3.0 provides a regional overview of the cultural history period for central Texas represented by the majority of the cultural remains encountered here. Chapter 4.0 describes the field methods implemented in 2005, the subsequent TRC laboratory procedures, terminology, and analytical techniques employed to generate data from the findings. Chapter 5.0 presents a general research design that guided and directed the analyses and discussions of the findings from the excavations following the fieldwork. Chapter 6.0 addresses a primary intermediate step in the research plan that would guide a subsequent part of the research. The geoarcheological methods and findings at Lynch Creek is presented in Chapter 7.0. Chapters 8.0, 9.0,

and 10.0 present the comprehensive information gathered from the field investigation combined with the subsequent laboratory analyses from each of the three sites, respectively. Chapter 11.0 provides a summary and conclusions of the findings for the project, and presents site specific recommendations for the three sites. This chapter is followed by a list of the references cited throughout the document. Finally, a glossary of technical terms used in this report that may not be familiar to all potential readers is presented.

Following the glossary, nine appendices (labeled A through I) are presented. These provide detailed data by technical experts who served as subconsultants and address specific analyses. Appendix A presents the raw geomorphological descriptions of trench deposits by geoarcheologist Dr. Charles D. Frederick. Appendix B provides laboratory reports from Beta Analytic Inc. and Center for Applied Isotope Studies at the University of Georgia on the radiocarbon dates obtained from the materials submitted during data analyses, the



procedures used in the dating process, and the various calculations for the obtained dates. Appendix C contains the processing procedures and individual results of the high-powered microscopic lithic use-wear analysis performed on 35 stone tools by Dr. Bruce Hardy. Appendix D presents the detailed procedures, handling, and individual results for 60 artifacts subjected to starch grain analysis by Dr. Linda Perry. Dr. Bozarth's phytolith analysis methods and presence/absence findings are presented in Appendix E. Appendix F presents the

procedures and findings from the complete phytolith analysis on samples from selected localities by Dr. Byron Sudbury. Appendix G is the "TxDOT Lithic Protocol Version 2.1, Chipped Stone Analytical Protocol" that was followed during lithic analysis. Dr. Dering's identification of the macrobotanical samples is presented in Appendix H. The lithic debitage analyses for sites 41LM50 and 41LM51 are presented in Appendix I along with the data regarding the the experiemental lithic debitage analysis.

## **2.0 ENVIRONMENTAL BACKGROUND**

Paul M. Matchen

### **2.1 PHYSIOGRAPHY AND HYDROLOGY**

Lampasas County lies in the eastern part of the Edwards Plateau or more specifically the Lampasas Cut Plain/Grand Prairie region (see Figure 1-1). The western margin of the county lies just inside the Llano Uplift or the mineral section, which exhibits rolling to hilly topography. The eastern margin is part of the Lampasas Cut Plain. The project area is in the extreme eastern portion of the county, a dissected upland with topography similar to that of the Edwards Plateau. The project is less than 5 km from the Colorado River. This region exhibits extensive limestone outcrops and exhibits some 305 m (1,001 ft.) of topographic relief with elevations that range between 213 and 519 m (699 to 1,702 ft.) above mean sea level.

The relevant section of the roadway crosses the limestone uplands just northeast of the Colorado River. It also crosses a number of small tributary creeks that includes Lynch Creek (Figure 2-1), which flows from the uplands into the Colorado River a short distance to the south and southeast. The Colorado River flows to the southeast through the Llano Uplift region, the Edwards Plateau, and then out onto the Coastal Plains towards the Gulf of Mexico. The small creeks and the Colorado River generally cut deep into the limestone with areas of Holocene alluvial deposition and areas of erosion along these water courses. Lynch Creek is deeply incised with very narrow Holocene alluvial deposits along its margins. Often these narrow areas are flushed out during intense rains or accumulate small quantities of alluvium that form cumelic soils.

### **2.2 GEOLOGY AND SOILS**

This project area lies in the eastern margin of the Edwards Plateau only a few kilometers east of the Llano Uplift and next to the Lampasas Cut Plain. The Lampasas Cut Plain and the Edwards Plateau consists of geological formations mostly of Cretaceous age, although the exposure of the cut plain itself is the result of Tertiary erosion (Barnes 1976). In general, the Strawn Group undivided lies north of the roadway, whereas the Marble Falls Formation lies to the south. The Strawn Group includes sandstone, shale, mudstone, conglomerate, siltstones, limestones, and small pebbles of chert. The Marble Falls Formation includes mostly fine to coarse grained limestones, local cherts and siliceous rocks, plus abundant marine fossils (Barnes 1976).

Site 41LM51 is near the edge of the Roughcreek-Rock outcrop soil complex, but is most likely included in the Weswood soil type. In general, the Roughcreek series consists of shallow, well-drained, undulating soils on uplands that formed in residuum weathered from dolomitic limestone. Slopes are 1 to 8 percent. These soils are characterized as shallow, undulating, well-drained with rock outcrops on broad, smooth areas. Intermittent occurrences of coarse limestone are evident on the surface, with sizes ranging from 15 to 91.5 cm (6 to 36 in.) (Allison 2001). Roughcreek soils have a top layer of neutral, dark brown very stony clay loam about 20 cm (8 in.) thick. The subsoil, from a depth of 20 to 43 cm (8 to 17 in.), is neutral, reddish brown, very stony clay. The underlying material, below a depth of 43 cm (17 in.), is coarsely fractured, indurated limestone bedrock nearly a meter thick. The Rock outcrop areas are typically long and narrow. Outcrops vary from 6 to 9 m (20 to 30 ft.) across and from 12 to 21 m (40 to 70 ft.) long, and may be up to 30 cm (12 in.) higher than the adjacent Roughcreek soil. Surface runoff is medium to high. Permeability of the Roughcreek soil is slow, the plant root zone





**Figure 2-1. Overview of roadway crossing Lynch Creek** (photograph by Allen Bettis).

is shallow, and available water capacity is very low. This complex has a severe water erosion hazard.

Sites 41LM49 and 41LM50 (and probably 41LM51) reside in soils that are characteristic of the Weswood silt loam (Allison 2001). This is a very deep, nearly level, well-drained soil mostly on the flood plain of the Colorado River. Limited areas of this soil type extend up major tributaries of the river. Slopes are dominantly less than 1 percent. These soil areas are oblong, oval, or long and narrow, and range from 12 to 141 hectares (ha, 30 to 350 acres) in size. These areas flood for brief periods about once in 20 years. Typically, the surface layer is brown silt loam about 20 cm (8 in.) thick. The upper part of the subsoil, from a depth of 20 to 111.7 cm (8 to 44 in.), is reddish brown or light reddish brown silt loam. The lower part varies from a depth of 111.7 to 203 cm (44 to 80 in.), is yellowish-red with strata of silt loam, silty clay loam, and fine sandy loam. The soil is moderately alkaline throughout. Surface runoff is negligible.

### **2.3 CLIMATE**

Lampasas County lies in an area with appreciable hot and cold weather in the summer and winter, respectively (Allison 2001). The area is marked by

sharp decreases in temperature dropping mild conditions to those that are extremely cold. The average minimum temperature is 0°C (32°F) in January, and the average maximum is 33.9°C (93°F) in July. The growing season averages 180 days annually (April through September). The rainfall is consistently distributed throughout the year with the annual average approaching 73 cm (29 in.).

### **2.4 FLORA AND FAUNA**

Biotically, the region is a relatively small transition zone referred to as the Balconian biotic province (Blair 1950). This lies between much broader provinces. To the east lies the more mesic Texas province, whereas to the west lies the more xeric Chihuahuan province. South of the Edwards Plateau or the Balconian province lies the semiarid Tamaulipan province with extensive brush lands. To the north is the massive mesquite (*Prosopis*) grassland of the Kansan province. Thus, the region sees a mixture of biota from the adjacent regions.

The regional vegetation is dominated by Mexican cedar (*Juniperus mexicana*) and Texas oak (*Quercus texana*) savanna across the uplands with some oak (including stunted live oak) and hickory



**Figure 2-2. View of dense Mexican cedar and various grasses as understory.**

(*Carya* spp.) woodlands mixed with a variety of other trees and grasses (Figure 2-2; Blair 1950). Various oak species including stunted live oak (*Quercus virginiana*), post oak (*Quercus stellata*), and blackjack oak (*Quercus marilandica*) are in abundance along with other minor species such as Texas persimmon (*Diospyros texana*). The more common juniper (*Juniperus mexicana*) that is associated with much of the limestone region is limited. Sotol (*Dasyllirion* spp.), prickly pear (*Opuntia* spp.), and various yuccas occur across the southern part of the county and further south. Much of the region is a mosaic of vegetation communities. Along the major rivers the arboreal species dominate and more species may be present. These can include the pecan (*Carya illinoensis*), American elm (*Ulmus americana*), and black willow (*Salix nigra*).

Minimally 57 species of mammals are known from the Balconian province (Blair 1950), including raccoon (*Procyon lotor*), rock squirrel (*Spermophilus variegates*), and nine banded armadillo (*Dasypus novemcinctus*). No species are totally restricted to this province and most range into adjacent provinces, creating a transitional region for most mammals. At least 15 species of frogs and toads are known, some 36 species of snakes, only one land turtle, and 16 species of lizards. Although Blair (1950) indicates the density of the mammals was usually lower than in the adjacent Tamaulipan province, it may be that a relatively greater diversity of plant and animal species, plus relatively abundant surface water and a range of mineral resources, drew prehistoric human populations to this region.

*This page intentionally left blank.*

### **3.0 CULTURAL BACKGROUND**

J. Michael Quigg

#### **3.1 INTRODUCTION**

This Lampasas project lies in the northern section of what is commonly referred to as the Central Texas Archeological Region in southwestern Lampasas County, Texas (Prewitt 1981, 1985; Figure 3-1). This chapter provides a broad, general overview of what is currently known about the cultural history of the Central Texas Archeological Region, which includes the Edwards Plateau and the neighboring Llano Uplift. In general terms, human occupation evident at the three prehistoric sites investigated includes minimally parts of four major time periods. The cultural assemblages probably represent the Early, Middle, and Late Archaic periods, plus the Late Prehistoric period. This chapter presents the relevant cultural background for the general cultural/chronological units pertinent to the major components identified as a result of this eligibility testing investigation. Few key differences exist in the stone tool assemblages and other aspects of the cultural systems for identifying the cultural complexes/phases present. The projectile points are the primary key, or recognizable time-diagnostic artifacts available, for assigning the cultural events to defined time periods. However, very few diagnostic projectiles were recovered. Those projectiles recovered, coupled with the subsequent radiocarbon dates obtained, are assumed to represent previously recognized cultural complexes across central Texas.

The Early and Middle Archaic periods appear partially represented at 41LM49 in the burned rock midden and by a Gower component in the lower T<sub>0</sub> terrace at 41LM51. The Late Archaic period is represented at 41LM51 in the upper T<sub>2</sub> terrace, and possibly in the lower zones at 41LM50. The Late Prehistoric period is represented in the top

component at 41LM50, and by a Toyah component in the top of the lower T<sub>0</sub> terrace at 41LM51. It was recommended that a data recovery program be conducted at 41LM50 and 41LM51 prior to bridge development if they could not be avoided (Quigg and Frederick 2005). It was anticipated that mitigation of these identified components would contribute significant information to each of their respected time periods; and therefore, that collected information would contribute to a greater understanding of human adaptations to this topographically diverse region.

#### **3.2 ARCHEOLOGICAL BACKGROUND**

Lampasas County, in the Lampasas Cut Plain bordering on the Llano Uplift and Edwards Plateau, has received limited archeological attention, consequently very little is known about the immediate area of this project. As of January 2008 only 59 trinomial site numbers had been assigned to this county. No large-scale systematic surveys or major excavation projects have been completed in Lampasas County. Many sites have been recorded along the Colorado River that runs along the western border of this county, whereas other sites are scattered about the county. One site of interest, further up the Colorado River, yielded a few sherds of Caddoan pottery (Field 1956:168).

Near the project, on the southwestern side of the Colorado River, in San Saba County, Texas Parks and Wildlife Department (TPWD) personnel conducted a partial survey of the Colorado Bend State Park (McNatt et al. 2001). In a 57 percent surface survey of 1,217.5 ha (3,021 acres) they recorded 39 archeological sites. Most diagnostic projectile points (Bulverde, Castroville, Montell, Frio, Ensor) observed reflect the Late Archaic period with nine arrow points (Perdiz and Scallorn) that represent the Late Prehistoric period. A single Bell point represents the Middle Archaic, whereas a single Jetta point indicates Early Archaic occupation. A

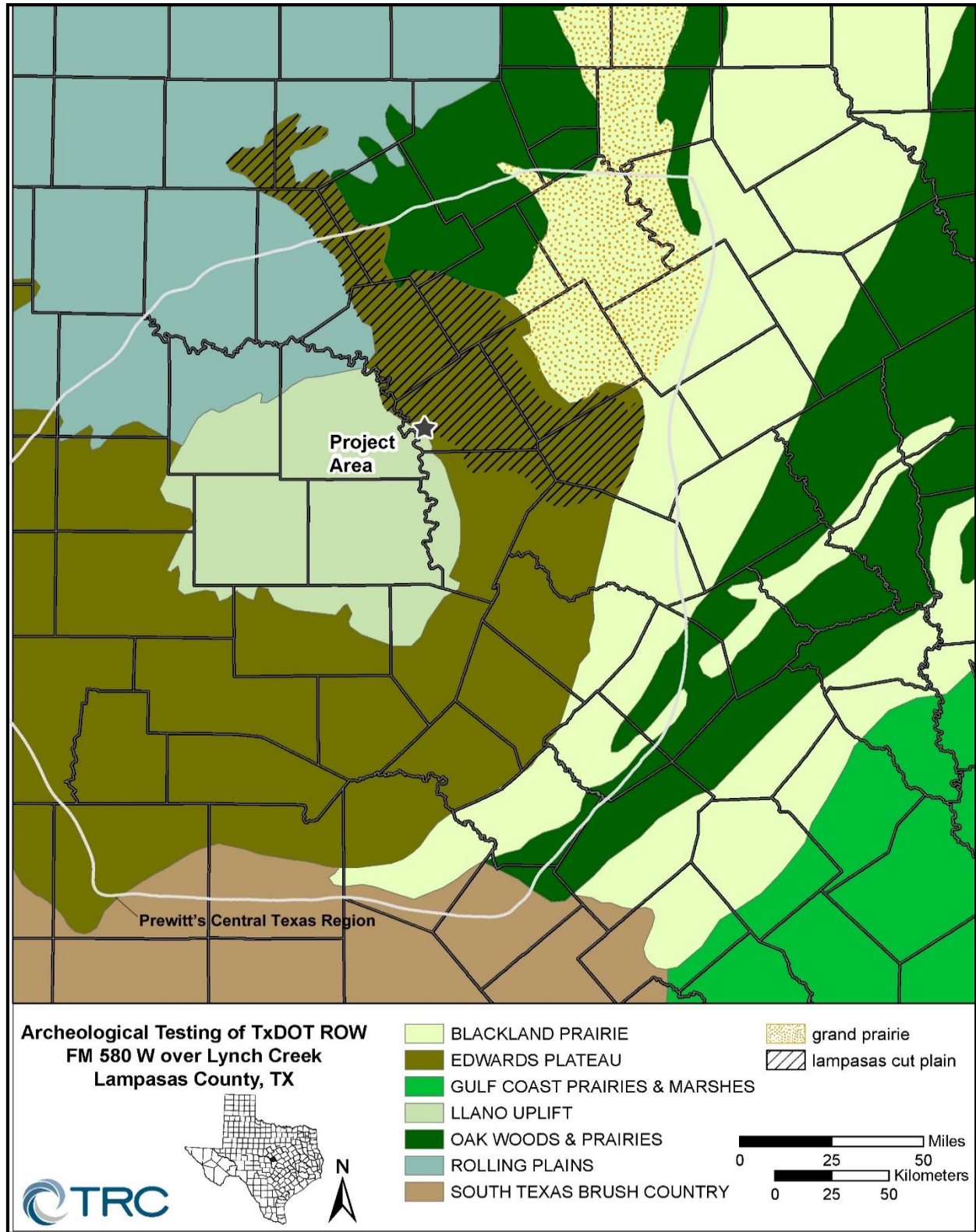


Figure 3-1. Prewitt's (1981) Central Texas Archeological Region overlaying physiographic regions.



wide range of chipped and ground stone tools were also observed during the TPWD survey. The prehistoric site types include open upland camps, terrace camps, lithic scatters, workshops, lithic procurement areas, rockshelters, burned rock middens, sinkholes, and pictographs.

Because few sites in this region have undergone extensive archeological excavations, information concerning the Lampasas region is extracted from investigations all across central Texas. Major archeological investigations and detailed reporting have been spotty across central Texas. Excavated sites with better context and larger data sets provide the majority of our understanding. Sufficient time and space is not available to review all sites or components that have been investigated in central Texas. An overview of the pertinent time periods with selected examples from individual sites provides the broad general background to this project.

In 1995, the Texas Archeological Society (TAS) published a comprehensive volume that summarizes much of what is known about Texas prehistory (Perttula 1995). A second summary with many of the same chapters was published by Texas A&M University Press (Perttula 2004). In those publications Collins's (1995, 2004) summarized central Texas archeology and combined with other key and relevant publications from which diverse information has been extracted (Prewitt 1981, 1985) that includes the Wilson-Leonard site report (Collins 1998), Johnson and Goode's (1994) reevaluation of the eastern Edwards Plateau climates and archeological periods, and others, provides much of the background information presented in this chapter. Collins's 2004 chronology provides a general timeline and diagnostic projectile points for the recognized cultural complexes in central Texas (Figure 3-2).

Below, the three major time periods projected for the occupations identified at the Lynch Creek

Archeological Periods	Years B.P.	Diagnostic Artifacts
Historic		
Late Prehistoric	-1,000-	Perdiz Scallorn, Edwards
	-2,000-	Darl Ensor, Frio, Fairland
Late Archaic	-3,000-	Marcos, Montell, Castroville Lange, Marshall, Williams Pedernales, Kinney
	-4,000-	Bulverde
	-5,000-	Nolon, Travis
Middle Archaic	-6,000-	Taylor
	-7,000-	Bell, Andice, Calf Creek
	-8,000-	Martindale, Uvalde
Early Archaic	-9,000-	Early Split Stem
	-10,000-	Angostura St. Mary's Hall
Late Paleoindian	-11,000-	Golondrina, Barber Wilson
	-12,000-	Dalton, San Patrice, Plainview Folsom
Early Paleoindian		Clovis

**Figure 3-2. Central Texas chronology** (from Collins 1995, 2004).

Bridge sites is provided to help place those site/components in context of what is known around the region.

### **3.3 THE EARLY ARCHAIC PERIOD WITH SPECIFIC EMPHASES ON SPLIT STEM PROJECTILE POINTS**

#### **3.3.1 Introduction**

Archeological investigations in the region have not revealed many well-stratified sites that exhibit good context with Early Archaic period projectile points or diagnostic tool types and/or cultural assemblages. The lack of Early Archaic excavated sites, coupled with the limited radiocarbon dates for this period, greatly hinders our understanding (see Collins 1995, 2004). In central Texas, the Early Archaic period is thought to begin at approximately 8800 B.P. and ends roughly around 6000 B.P.

(Collins 1995, 2004) or 5500 B.P. (uncalibrated) (Johnson and Goode 1994).

Specific beginning and ending dates continue to be refined as additional archeological work is reported, and more radiocarbon dates are obtained and presented from good contexts. McKinney (1981) conducted an assessment of early Holocene adaptations. In his study he lists only 45 Early Archaic sites for central and southwestern Texas. Nearly half the sites ( $N = 21$ ) listed represent surface contexts that include surface collections such as that from Granite Beach (Crawford 1965). Since then, a number of Early Archaic sites across a broad region have been investigated and reports with syntheses and discussions concerning the Early Archaic period in central Texas. Selected sites include in Camp Pearl Wheat (Collins et al. 1990), Sleeper (Johnson 1991), 41TG307 and 41TG309 (Quigg et al. 1996), Wilson-Leonard (Collins 1998), Woodrow Heard (Decker et al. 2000), Cibolo Crossing (Kibler and Scott 2000), Armstrong (Schroeder and Oksanen 2002; Schroeder 2011), Berdoll (Karbula et al. 2011); Richard Beene (Thoms et al. 1996; Thoms and Mandel 2007), and Varga (Quigg et al. 2007b); Ice House (Oksanen 2011)(Figure 3-3), which provide valuable insights into the Early Archaic period, slowly increasing our understanding of this period.

The Early Archaic period is considered to represent the transformation from highly mobile, big-game hunting Paleoindian lifeways to adaptations that involved diversified economies that relied on smaller game and varied plant resources. It was also a time at which hot rocks became a key element in the cooking process. The subsistence base is not known in detail, since most sites dating to this period have poor bone and organic preservation. Diversification is perhaps expressed in the stone tool assemblages, which incorporate ground stone plant processing tools, as well as hunting and butchering tools into the artifact assemblage. While ground stone tools are generally scarce at Early

Archaic sites, they are reported in some abundance from the Sleeper site (Johnson 1991), thus indicating relatively intensive plant processing at some locations.

The cooking technology appears to have also changed from the Paleoindian period as burned rocks, employed to transfer heat to foods, became more prominent in Early Archaic assemblages. Burned rocks appear in general scatters, small hearths, large ovens, midden-like accumulations, and became increasingly abundant with the passage of time.

Dart tips during the Paleoindian period were primarily lanceolate forms (i.e., Clovis, Folsom, St. Mary's Hall, and Plainview) that changed to mostly notched and/or stemmed forms (i.e., Gower, Hoxie, Martindale, and Uvalde) in the following Early Archaic. One persistent lanceolate form, the Angostura type, apparently spanned the transition from Late Paleoindian to earliest Archaic. The number of types of projectile points also increased during this period. The "diagnostic" points of the Early Archaic period include Angostura, Baker, Bandy, Gower, Hoxie, Jetta, Martindale, and Uvalde. At Wilson-Leonard, a certain degree of morphological and technological continuity was detected between Angostura and some early bifurcate forms (e.g., certain Hoxie variants), namely lateral stem edge grinding; shallow, ground basal concavity in an arc-shaped configuration; and long narrow stems or bases (Dial et al. 1998:425). Other projectile point technological aspects are presented by Dial et al. (1998) that focus on lateral stem edge grinding, secondary flaking, and basal modifications.

Currently, the Early Archaic is subdivided into three projectile point style intervals, Angostura, Early Split Stem, and Martindale-Uvalde (Collins 1995, 2004; Johnson and Goode 1994). The latter authors presently believe the Early Triangular and Bell/Andice points are part of the Middle Archaic. However, the limited frequency of any one point

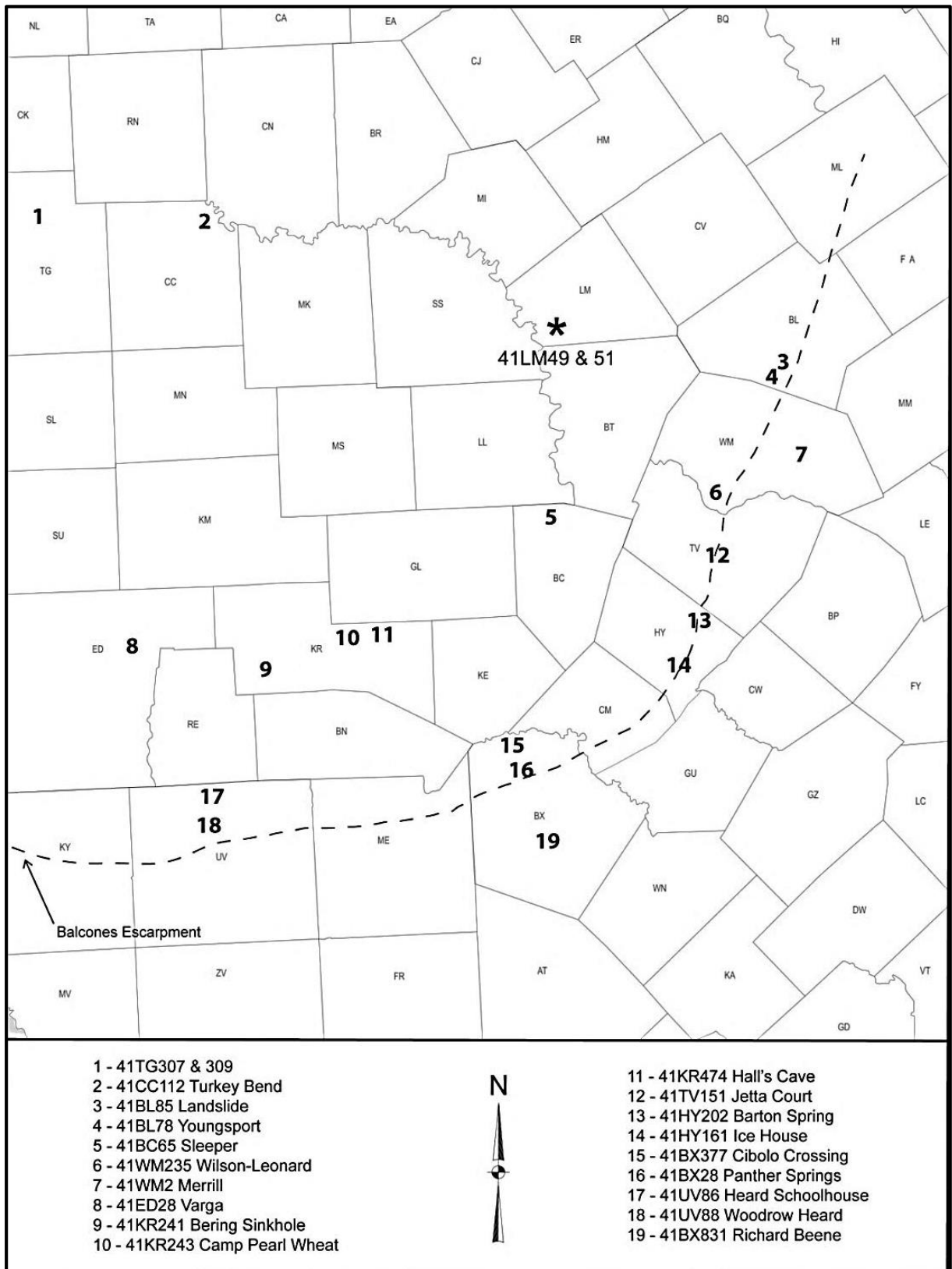


Figure 3-3. Selected Early Archaic sites in central Texas.



type from any one site, the often poor context and mixing of components that yield these point types, the questionable accuracy of some projectile type identifications, and the general lack of supporting radiocarbon dates have all contributed to our poor understanding of the precise age and chronological sequencing of the different point types within this period. Given the various problems in identifying individual point types, authors have employed broad descriptive point categories instead of trying to type individual points. Terms such as Early Barbed (Johnson 1964), Early Corner-Notched (Hester 1971), Early Split Stem (Johnson 1991), Contracting Stem (Dial et al. 1998), Expanding Stem (Dial et al. 1998), and Bifurcate Stemmed (Dial et al. 1998), are currently common in the literature. Johnson (1964) originally used his Early Barbed construct as a catch-all group, but presently this and other broad descriptive categories have become a means of grouping points. Although these terms are useful for observing broad trends in point styles, the use of broad categories may mask cultural patterns that may be discernable throughout this time period based on stylistic variation within and among individual point types. It may be possible to establish the stylistic variations among the broader groupings.

Most Early Archaic projectile point types are not well-dated by directly associated radiocarbon dates. However, general site context and stratigraphic positions of radiocarbon dates and projectile points provide indications as to which point types occurred earlier than others, and provide broad chronological context and time frames.

### 3.3.2 The Gower Point and Split Stem Series

An Early Archaic projectile fragment identified as a Gower point from the lower T<sub>0</sub> terrace at 41LM51 falls within Collins's (1995, 2004) Early Archaic, Split Stem series. Three *Rabdotus* shells from that component yielded a  $\delta^{13}\text{C}$  (-10.5‰) corrected AMS date of 6750 ± 50 B.P. (UGA-14422).

Also, at least one radiocarbon date (6660 ± 50 B.P.; UGA-14415) on a *Rabdotus* snail shell from Burned Rock Mound 1 (BRM 1) at 41LM49 falls within the Early Archaic period. The following discussion centers on the Gower point type and the general Split Stem series of the Early Archaic period.

The Gower point was first recognized at the Youngsfort site, a stratified site in alluvial deposits in Bell County (Shafer 1963) just southeast of Lampasas County (see Figure 3-3). Vertical stratigraphy was generally good with eight strata identified within roughly 260 cm of deposits.

Fourteen Gower specimens from the lowest stratum (Stratum 8, roughly 30 cm thick) revealed some morphological variations. This was the only point type recognized from this stratum. The points were described as crudely made, with indented bases; short, parallel-edged stems; and the markedly concave bases apparently made by the removal of a single flake (Shafer 1963). Lateral stem edge grinding was not characteristic of these points, although Gower variants did display edge dulling. These Gower points were stratigraphically below younger point types such as Bulverde, Nolan, Wells, and Uvalde. However, radiocarbon dates were not obtained for this Gower component. Stratum 8 also yielded two bifaces, two scrapers, a Clear Fork Gouge, lithic debitage, burned rocks, and snail shells.

Since that discovery a number of other excavated sites have yielded similar projectile points including Landslide (Sorrow et al. 1967), Jetta Court (Wesolowsky et al. 1976), Sleeper (Johnson 1991), Richard Beene (Thoms 1992; Thoms and Mandel 2007), Wilson-Leonard (Collins 1998; Dial et al. 1998), Varga (Quigg et al. 2007b), and Ice House (Oksanen 2011)(Figure 5-3).

Gower points are also recognized much further west in the Lower Pecos region at sites like Devil's Rockshelter (Prewitt 1966). Gower points are

morphologically similar to Uvalde and Hoxie forms (see Turner and Hester 1993; Kerr and Dial 1998). The 32 Gower points recovered from the Varga site may be the largest single sample of this point type thus far, but these points were recovered from a compressed Early Archaic stratigraphic zone that included numerous other Early Archaic point types. The same can be said for most of the 14 Gower points from the Wilson-Leonard site, where the type exhibits a wide range of metric and nonmetric variation. The detailed presentation of Gower data in the Wilson-Leonard collection is quite useful, but Dial et al. (1998) note that this type, with its similarity in stem morphology to both Uvalde and Hoxie, is problematical. Much is yet to be learned about this point type and similar forms.

Although these and other sites/components have yielded Gower points, poor organic preservation, stratigraphic complexities, and mixing of deposits has severely limited the radiocarbon dating of this type, associated events and features, and an understanding of the associated subsistence base if preserved. One of the better stratigraphic and temporal contexts is at the Ice House site (41HY161) in San Marcos, where three occupation zones (Zones 1, 2, and 3) spanning some 60 cm of deposits have yielded Gower points. These zones were radiocarbon dated by three bone collagen dates to between 7700 B.P. and 6650 B.P. (Oksanen 2011).

Above the well-dated and sealed Angostura component in the Upper Perez Paleosol at the Richard Beene site south of San Antonio lie several Early Archaic occupations beginning with a  $6930 \pm 665$  B.P. (Beta-47525) date associated with stemmed and indented-base Gower-like points (Thoms et al. 1996). An estimated age of 5500 B.P. for a hearth buried in the Medina Paleosol, which yielded a soil humate date of  $6450 \pm 135$  B.P., was believed the youngest of the Early Archaic materials at this site (Thoms 1992). Currently, Gower points are radiocarbon dated to sometime

between roughly 7700 and 5500 B.P. based on less than a dozen dates.

In addition to the projectile points, other items commonly recovered from Early Archaic period tool assemblages include various bifaces, end and side scrapers, Guadalupe tools, gouges, grinding implements such as manos and metates, drills, flake tools, burins and burins spalls, and edge-modified flakes. Clear Fork tools/gouges were once thought indicative of specialized wood working tasks (Hester et al. 1973; Howard 1973), but more recent high-powered micro-wear studies indicate that Clear Fork tools had multiple functions that include; woodworking, defleshing, and scraping (Church 2000; Hardy 2002; Hudler 1997; Root et al. 2008). Some sites have yielded gouges (e.g., Wilson-Leonard), whereas other sites lack this tool (e.g., Sleeper). The differences in occurrence of specific tool types at individual sites may reflect that different tasks were performed at different sites. Guadalupe tools are also thought to reflect primarily woodworking and “percussive cutting tools” (Brown 1985). Grinding implements are quite frequent at a few sites (i.e., 47 metate fragments and 70 manos at the Sleeper site), but are not present at most other sites (e.g., Camp Pearl Wheat), which again may reflect task-restricted sites/components and/or indicate different exploitative strategies. A rare engraved pebble recovered in Early Archaic context at the Turkey Bend Ranch site (Lintz et al. 1995) probably reflects a non-utilitarian object. If so, this object implies the users had time for recreational or ritualistic activities.

Early Archaic human remains are scarce in central Texas, with the exception of what has been recovered from sinkholes such as the Bering Sinkhole (Bement 1991, 1994) in Kerr County. The latter site provides the best-documented evidence of patterns of disposal of human remains for this time period. Apparently 20 bodies, one bundle, two

Cremations, and 17 others were dropped or lowered into sinkholes for their final resting place during a period from roughly 5100 to 7100 B.P. The different strategies employed in disposing of human bodies may indicate different belief systems within the Early Archaic populations.

The dental caries rate per person is a relatively low (0.69) for those employing the Martindale and Uvalde points (San Geronimo phase; Bement 1994:93). The low ratio is indicative of a diet relatively low in carbohydrates. Stable carbon isotope analyses on the human bones from Bering Sinkhole indicate the diet consisted of 54 percent C3 and 46 percent CAM/C4 foodstuffs. Direct subsistence data is sparse because preservation of organic materials is poor in most Early Archaic components.

Prewitt (1981) thought that hunting and gathering occurred with an emphasis on gathering for a general mixed economy. Currently, the recovered data provides a very skewed picture of past subsistence resource utilization patterns. When bone has been preserved and recovered from an early occupation zone, some researchers have neglected to address the potential for natural species to be incorporated into archeological deposits. Deer, various small animals, and fish are all indicated as probable resources (Collins 1995, 2004). Freshwater mussel and snail shells are common in many components such as at the Landslide site (Sorrow et al. 1967), the Sleeper site (Johnson 1991), and 41TG307 and 41TG309 (Quigg et al. 1996). Deer and turtle bones were present in stratigraphic association with the Martindale and Uvalde points at the Bering Sinkhole (Bement 1994:82), whereas deer elements dominated in the lowest levels associated with 11 Uvalde/Martindale points at Panther Springs (Black and McGraw 1985). Taxa represented by burned bone during this period at the Wilson-Leonard site include turtle, rabbit, carnivore, and deer/antelope (Baker 1998; Collins 1998).

Analyses of organic residues in burned rocks from Camp Pearl Wheat indicate that plant, as well as animal products, were processed during this period (Collins et al. 1990). Minimally 10 charred wild hyacinth/eastern camas bulbs from a burned rock oven (Feature 181) in the Early Archaic strata at the Wilson-Leonard site were dated to 7870 to 8420 B.P. (Collins 1998; Dering 1998, 2007). Occupation Zone 3 at the Armstrong site yielded two lily family bulb fragments from Feature 2 (Schroeder and Oksanen 2002; Schroeder 2011).

The Berdoll site (41TV2125) also yielded some faunal remains that include mussels, deer, rabbits and others species along with onion bulbs, seeds, acorns, and walnut shells that reveal diverse food resources (Karbulla et al. 2011). The Early Archaic component at the Varga site yielded deer/antelope bones, a few rabbit bones, mussel shells, prickly pear seeds, and walnut pericarp fragments, which also indicate a diverse resource base (Quigg et al. 2007b; Dering 2007). The Angostura component at the Richard Beene site, just south of the southern edge of the Edwards Plateau, yielded charred sotol or yucca leaf bases that dated to 8000 B.P. (Thoms and Mandel 2007). Although not radiocarbon dated, the Early Archaic Sleeper site did yield two mano caches that imply plant processing was an activity pursued there. Apparently, the subsistence base was very broad, and peoples exploited diverse riverine and terrestrial resources. Deer-size game dominated the faunal assemblage that also included small game at Ice House (Oksanen 2011). Dering (2007) sees this period marked by the use of earth ovens to cook large quantities of plant resources with the eastern side of the plateau initiating this process earlier than the western side. The eastern side focused on cooking geophytes or bulbs, whereas the western side focused on cooking evergreen rosettes, agave and sotol.

The discovery of large cooking features, burned rock hearths, and ovens at many sites (i.e., Sleeper, Richard Beene, Wilson-Leonard, Woodrow Heard;

Berdoll, and Cibolo Crossing) indicates that large quantities of plant foods were cooked in the Early Archaic period (Dering 2007). Small basin hearths such as those at the Sleeper site, Armstrong, Barton Creek (41HY202), Varga, and 41TG307 may reflect different cooking processes for different types of foods, or even non-cooking elements. The “baking heaps” at the Sleeper site are said to have been mostly one stone thick, generally elongated with flat bottoms that lacked organic staining (Johnson 1991:49), rather than suitable for use as ovens. The three cooking hearths at the undated Sleeper site are smaller than the “baking heaps”, lined with flat slabs, and slightly basin shaped (Johnson 1991:51). Massive burned rock mounds or middens have not been recognized for the Early Archaic in central Texas.

Further northwest and upstream along the Colorado River, excavations at the Turkey Bend site (41CC112) in O. H. Ivie Reservoir revealed a 5.8-by-5.4 m circular rock structure that was radiocarbon dated to 7500 B.P. This apparent structure contained a large, 3.1-by-2.7 m, and 33 cm thick, rock lined hearth-like feature that encompassed most of the interior space of that rock structure (Lintz et al. 1995; Treece et al. 1993a). The function of this internal feature is unknown, but the central rock mass was probably a plant-cooking feature. Feature 22 at Cibolo Crossing, a large 200-by-380 cm flat concentration of burned rocks contained 24 pieces of lithic debitage, and 700 *Rabdotus* shells, but without charcoal staining, was interpreted to have been used with *Rabdotus* snails (Kibler and Scott 2000). Collins (1995, 2004) sees this period as the beginning of specialized cooking appliances, which he projects as the antecedents of the larger burned rock middens of later Archaic times.

Many researchers have recognized a broad regional distribution of Early Archaic sites and materials, with multiple diagnostic artifact forms widely distributed across much of Texas. For example,

Gower points, Gower-like points, and Guadalupe tools have been recovered from central and southwestern parts of Texas (McKinney 1981). Kibler and Scott (2000) believe Early Archaic site distribution at Camp Bullis in San Antonio reflect spatial patterning of subsistence activities. In their analysis of the site distribution at Camp Bullis, sites that yielded Martindale points are concentrated in and along the fringes of the Balcones Canyonlands. This is similar to the distributional pattern observed by McKinney (1981) for Gower points. McKinney’s (1981) findings revealed that many known Early Archaic sites appear concentrated along the southern edge of the Edwards Plateau, which implies a linkage with a greater abundance of resources that includes water, at a time when the climate was somewhat drier.

In 1991, Johnson reviewed and discussed 11 important excavated Early Archaic sites that were distributed from the eastern edge of the Edwards Plateau around the Austin area, westward across the Edwards Plateau to include the Lower Pecos region. The sites Johnson discussed form a “crescent” shaped distribution pattern across an east-west section through central Texas. This distribution may or may not have any real meaning, but may reflect a biased sample of excavated sites. The two extreme ends of this crescent are currently in two different archeological regions, the Central Texas and Lower Pecos Archeological Regions. The Lampasas sites fall toward the northwestern side of the crescent area in the Central Texas Archeological Region.

### **3.4 THE MIDDLE ARCHAIC PERIOD IN CENTRAL TEXAS**

Johnson and Goode (1994) proposed a tentative revision of Weir’s (1976) and Prewitt’s (1981, 1985) Archaic periods for the eastern parts of the Edwards Plateau. This revision was accepted and used by Collins (1995, 2004) in his synthesis. Collins (1995, 2004) divides the Middle Archaic into three subdivisions based on projectile point

types for the period between roughly 6000 and 4000 B.P. The earliest is the Bell/Andice/Calf Creek style, followed by the unnotched Taylor, and then the Nolan/Travis series. A significant change comes with the Johnson and Goode (1994) reassignment of Prewitt's Early Archaic point types, including Bell/Andice, Baird, and Taylor triangular points to the Middle Archaic. Prewitt's (1981, 1985) previously assigned Middle Archaic point types, including Bulverde, Pedernales, Marshall, and Williams that Johnston and Goode (1994) are placed within the Late Archaic period. This may confuse many readers as most literature refers to these later points according to Prewitt's chronology.

Johnson and Goode (1994) propose a period of about 1300 years from about 5600 to 4300 B.P. for the Middle Archaic, although Collins (1995, 2004) time frame is slightly broader and incorporates nearly 2000 years from 6000 and 4000 B.P. These revisions push back the time of the Middle Archaic as defined by Prewitt (1985).

The Bell/Andice/Calf Creek dart points dominate the early part of the Middle Archaic period at roughly 6000 B.P. and are assumed to correlate with bison hunting. Bison presence in central Texas at that time is not well-established, although the Landslide site (41BL85) reveals a bison bone in apparent association with one Bell/Calf Creek point (Sorrow et al. 1967; Figure 3-4). A second possible bison association was at the Cervenka site (41WM267), which also yielded several bison bones scattered around a small, shallow basin hearth—Feature 26. This feature was thought to reflect a period estimated to fall between 6000 and 5000 B.P. (Peter et al. 1982). The vertebrate faunal assemblage from the excavations at the Big Hole site (41TV2161) just east of Austin appears to contradict the assumption that the populations using the Bell/Andice/Calf Creek points were primarily bison hunters. The initial faunal analysis indicates that bison bones were not present in the

faunal assemblage that is dominated by small game animals (Matchen and Quigg 2007; Quigg et al. 2007a). A dense burned rock feature associated with an Andice point at 41MS69 in Mason County also supports plant processing by these populations (Quigg and Frederick 2005).

A limited number of other intensively investigated sites have yielded a few Bell/Andice projectile points and those include; Granberg II (Black and McGraw 1985), McKinzie (Ricklis 1988, 1993), Barton Creek (Collins 1994), Richard Beene (Thoms and Mandel 2007), Wilson-Leonard (Collins 1998), Cibolo Crossing (Kibler and Scott 2000), Royal Coachman (Mahoney et al. 2003a), and the Big Hole site (Quigg et al. 2007a) (Figure 3-4). At the Granberg II site (41BX271), a Bell point along with a number of other early dart point forms were associated with a radiocarbon date of  $4770 \pm 110$  B.P. (uncorrected, Tx-3606 [Black and McGraw 1985:325]). A Bell component at the Richard Beene site was dated to ca. 4500 B.P. (Thoms and Mandel 2007). Southeast of central Texas in Nueces County along the coast, a Bell point was associated with calibrated dates between 5900 and 5300 B.P. based on *Rangia flexuosa* shells at the McKinzie site (Zone 3, Ricklis 1993:49). At the Royal Coachman site (41CM111), three Bell/Andice points were recovered from excavation levels that also contained nine Early Triangular, five Pandale, and five Nolan points associated with five charcoal dates ranging in age from about 5000 to 4700 B.P. (Mahoney et al. 2003a). Charcoal from a dense burned rock Feature 1 at 41MS69 yielded a series of four dates;  $4890 \pm 40$  B.P.,  $5000 \pm 40$  B.P.,  $5070 \pm 40$  B.P.,  $5120 \pm 40$  B.P., associated with one Andice point base (Matchen and Quigg 2007; Quigg and Frederick 2005).

Also, the Big Hole site (41TV2161) has yielded a series of nine radiocarbon dates from 5800 to 5300 B.P. for a deeply buried, well-defined component that contains Bell/Andice/Calf Creek points (Quigg et al. 2007a). The Cibolo Crossing site (41BX377)

had good but not great context. The 16.8 m<sup>3</sup> investigated Bell component yielded nine Bell points, one Andice point, and two Baird triangular bifaces. Based on the average of three charcoal dates from Feature 19, this component was radiocarbon dated to 4400 B.P. (Kibler and Scott 2000). These radiocarbon dates are contributing to establish the age range of the populations using the Bell/Andice/Calf creek points in Texas.

Later in this period was the occurrence of Early Triangular, La Jita, Travis, and Nolan points, and possibly Merrill points (Johnson and Goode 1994). The unnotched Taylor or Early Triangular points were the dominant projectile (n = 27 or 51 percent of the total) at the burned rock midden excavated at Wounded Eye site (41KR107) in Kerr County (Luke 1980). However, this midden was not radiocarbon dated to document the actual use period. Mahoney et al. (2003a) believe that the Royal Coachman site yielded one of the more securely dated Early Triangular components in Texas with five of six radiocarbon assays from wood charcoal returning one-sigma calibrated ages ranging from 5600 to 5460 B.P., which would put the uncalibrated ages roughly 4800 to 4900 B.P. These ages appear earlier than most known ages, but it may be that these styles have a long use period that is contributing to the difficulty in trying to narrow down the time frame in which these triangular points were used.

Nolan and Travis points, both with stemmed bases and rounded shoulders (Turner and Hester 1993) became the dominant types in the last part of the Middle Archaic (Collins 1995, 2004; Johnson and Goode 1994). The Nolan points are most often well-made in comparison to the more crudely knapped Travis points (Johnson and Goode 1994:27). Although not well-documented, Johnson and Goode believe that the Nolan and Travis points are no earlier than about 5000 B.P. Goode believes the La Jita and the Travis points are of the same age

as they share similar manufacturing features (Johnson and Goode 1994:27).

Johnson and Goode (1994) see the Middle Archaic as a time of considerable borrowing of alien artifacts styles or new artifact styles brought into the area. They project mixed economies with burned rocks middens reflecting intensive periods of plant collection and processing. They also link the burned rock middens with Nolan and Travis points. Two burned rock middens dominated the Middle Archaic deposits at the Wilson-Leonard site (Collins 1998).

Other than these two large middens, small burned rock clusters (less the 130 cm in diameter) were in similar age context at Wilson-Leonard. Toward the latter part the Taylor period and into the Nolan and Travis point type period, bison are not readily apparent in the archeological record (Dillehay 1974). It is not clear when bison moved from the region. A variety of food resources including rabbit, turtle, rodent, deer, snake, mussels, and fish were in a Middle Archaic context at Wilson-Leonard (Baker 1998; Collins 1998).

Evidence for burial practices in the eastern Edwards Plateau is nearly non-existent. The Mason Burial Cave (41UV4), a sinkhole in Uvalde County on the southwestern edge of the Plateau, revealed some 25 to 50 bodies in 9.8 m of deposits. A few of the bodies are linked with Travis, Nolan, and Early Triangular points (Bender and Bender 1962 cited in Johnson and Goode 1994:28).

The paleoenvironment is not well understood. Johnson and Goode (1994) see this period as moderately moist but drying. This contrasts with the data from Fort Hood, which Nordt (1992, 1993) interprets as a dry/xeric period that had increases in C4 grasses at the expense of C3 trees and shrubs. Phytolith and snail data from the Middle Archaic deposits at Wilson-Leonard support xeric conditions. Pollen data from the bogs just east of

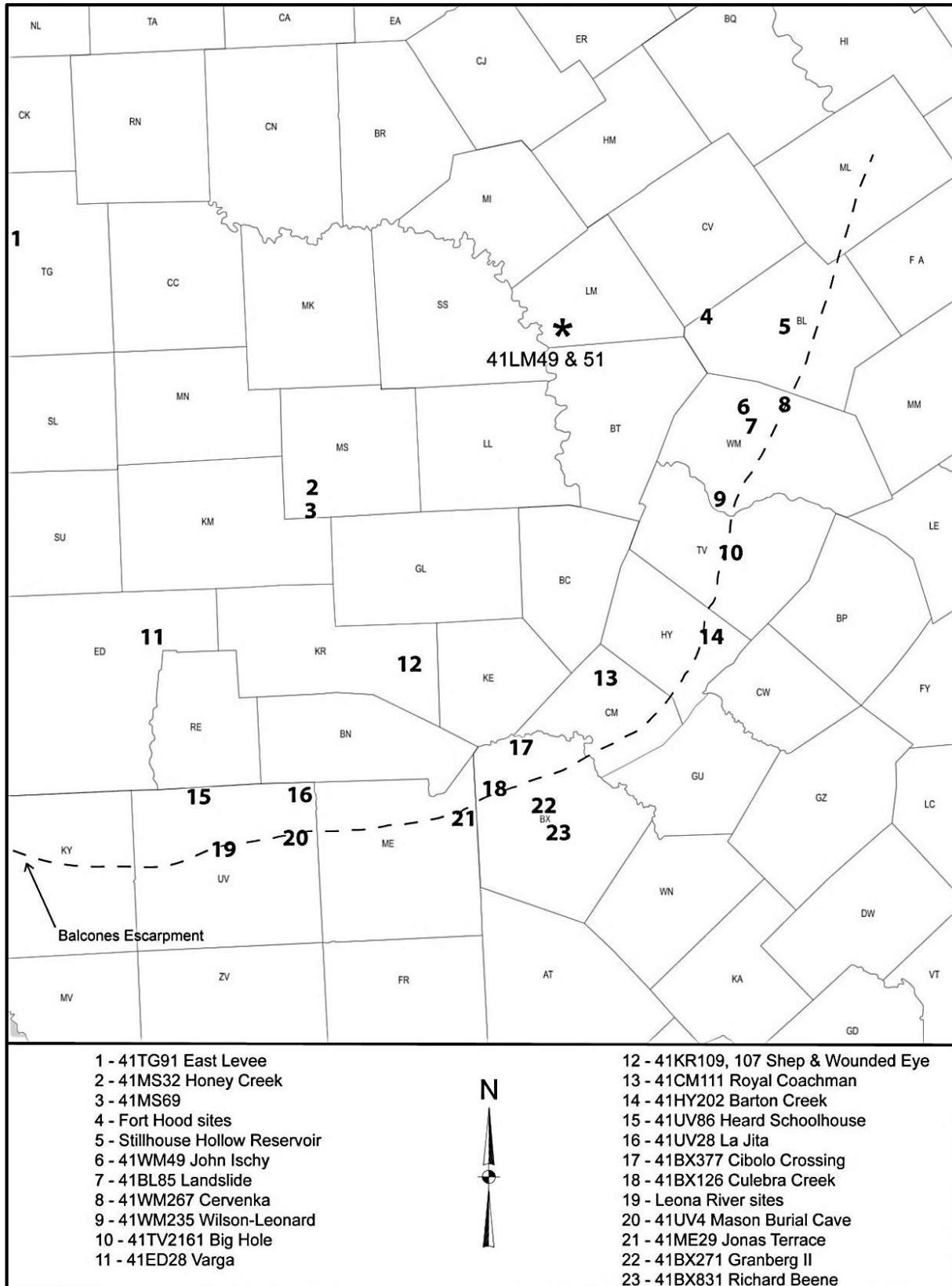


Figure 3-4. Selected Middle Archaic sites in central Texas.

the plateau indicate a region dominated by grasslands (Bousman 1998).

This author interprets the current data to indicate that populations that employed the Nolan and Travis points were the prominent local groups in the central Texas region at that time with Bell/Andice/Calf Creek point using populations intruded from the north and the Early Triangular point using populations intruded from the south.

This also assumes that all the point types are contemporaneous, which is very questionable, and only additional radiocarbon dates will resolve. The events reflected by the different point types may all be very close in time, and coupled with poor stratigraphic context at most sites, has not allowed shorter subperiods to be accurately defined. The lack of significant time and deposition between events, coupled with the erosional and depositional sequences, have often mixed these points types together. Therefore, until short-term occupations isolated from other components are located, excavated, and well-dated, our understanding will be limited.

### **3.5 THE LATE ARCHAIC PERIOD IN CENTRAL TEXAS**

In central Texas, the Late Archaic period is roughly dated to between 4000 and 1300 B.P. This period is currently divided into six intervals based on different projectile point types (Collins 1995, 2004).

Previously, Prewitt's (1981) chronological sequence consisted of three phases represented by different point types: Uvalde phase (Castroville, Marcos, and Montell points), Twin Sisters phase (Enser points), and Driftwood phase (Mahomet [Darl] points). Therefore, one must pay close attention to the publication author and date to keep these cultural divisions clear when an author refers to a general time period such as the Late Archaic.

Many archeological sites which represent this time period have been excavated, although few well-stratified components are represented and thoroughly radiocarbon dated and reported (Collins 1995).

Many sites/components have yielded Late Archaic point types from a single broad zone or stratigraphic layer (e.g., Jonas Terrace [Johnson 1995]; Wilson-Leonard [Collins 1998]; Bessie Kruze [Johnston 2000]; 41WM815 [Brownlow 2003]; Millican Bench [Mauldin et al. 2004]; Varga [Quigg et al. 2007b]) (Figure 3-5). This raises the possibility of mixing of occupational events or the remains of multiple groups that cohabitated the same sites.

Johnson and Goode (1994) provide a slightly different view by subdividing this period into early ("Late Archaic I") and late ("Late Archaic II") subperiods. Their two part division is based on perceived changes in the archeological record. During the Late Archaic I period, the common dart points include Bulverde, Pedernales, Marshall, Montell, and Castroville. In Late Archaic II period, the common dart points are Marcos, Enser, Frio, Darl, and Figueroa. Johnson and Goode (1994) indicate a time of about 2500 B.P. for the division of the two subperiods.

Data recovery investigations at 41MM340 in Milam County along the eastern border of the Blackland Prairie and western margin of the Oak Woods and Prairie (see Figure 3-5) revealed a deeply stratified site that reflected 15 stratigraphic zones grouped into seven analytical units (AU). Recurrent occupations were well-dated and spanned nearly 1,000 years between 3000 and 2000 B.P. (Mahoney et al. 2003b). Pedernales points dominated AU 6, whereas Marcos and Marshall points dominated AUs 4 and 5, respectively. Multiple point types were present in AU 2. The diet of all the groups represented throughout that 1,000 years was diverse, with a greater reliance on riverine resources early in the sequence. Increased



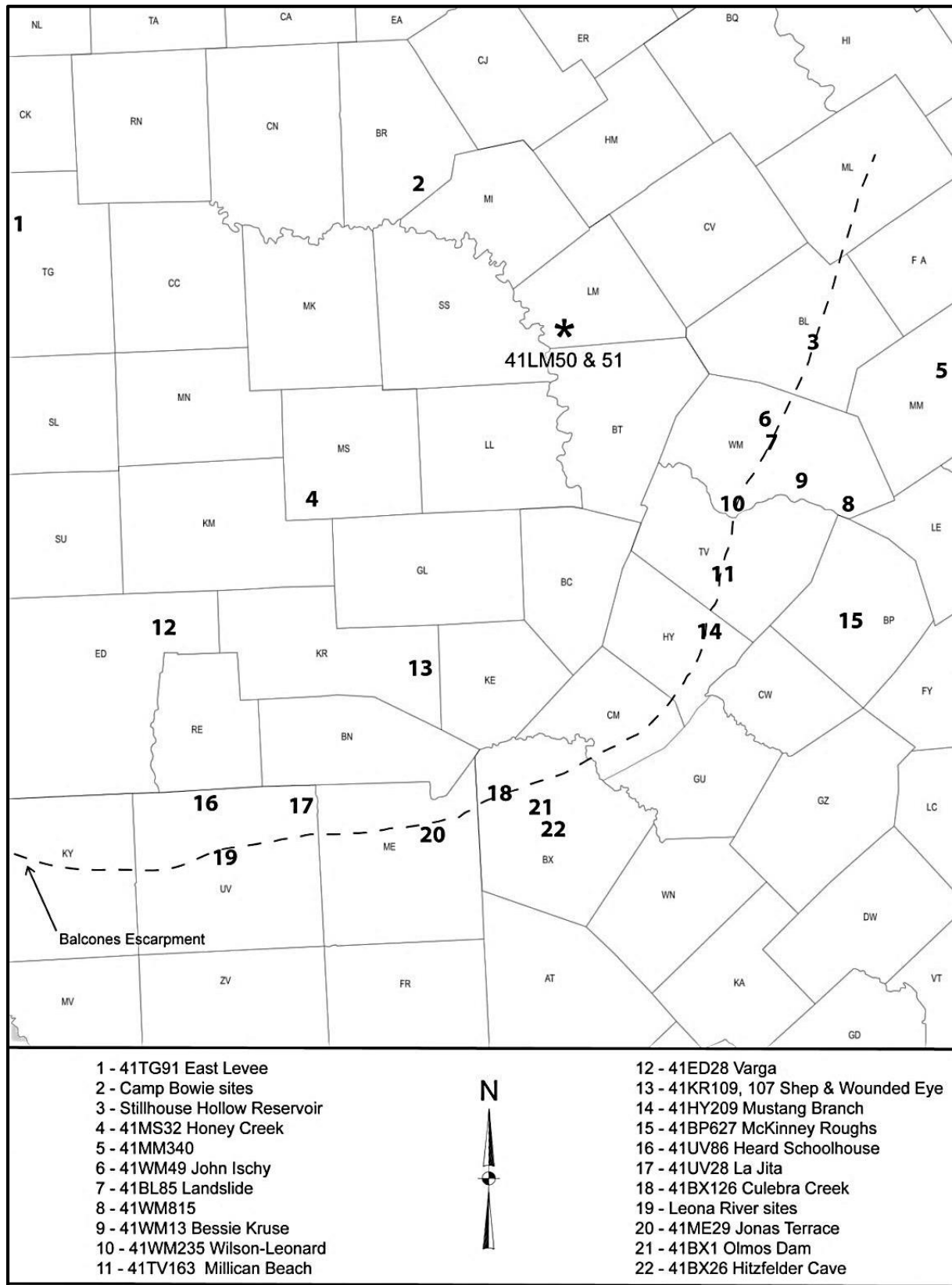


Figure 3-5. Selected Late Archaic sites in central Texas.

frequencies in burned rock clusters in the upper analytical units were detected. The authors also detected considerable, yet patterned regional variation in Pedernales stem forms in a comparison with ten other sites. Tool kit refurbishing was probably one of the principal activities, although the recovered tool assemblage was dominated by expedient tools.

Two other sites with good context and radiocarbon dates associated with Marcos, Montell, and Marshall projectiles (Uvalde phase) include 41GT91 and Culebra Creek (see Figure 3-5). At 41TG91 (East Levee as referred to by Johnson) near San Angelo, Marcos points were associated with three radiocarbon dates of  $2910 \pm 270$  B.P. (Tx-4764B),  $2540 \pm 80$  B.P. (Tx-4764A), and  $2480 \pm 60$  B.P. (Tx-4761) (Creel 1990). At Culebra Creek site near San Antonio, three Montell and one Marshall point came from a thin burned rock midden associated with two charcoal dates of  $2700 \pm 50$  B.P. (NSRL-3520) and  $2780 \pm 50$  B.P. (NSRL-3519) (Nickels et al. 2001). These two sites and associated radiocarbon dates indicate these three point types can occur as separate entities. The dates for Montell points at Culebra are earlier than indicated by Collins' (1995, 2004) chronology, but appear very similar to the dates suggested by Johnston and Goode (1994). These data indicate a roughly 1,000-year time frame that bracketed the use of Pedernales, and then Ensor and Frio points, ca. 3000 to 2000 B.P.

Data recovery at the McKinney Roughs site (41BP627) yielded an isolated Darl point component in good context overlying an earlier Ensor point component (Carpenter et al. 2006). The Darl point component was radiocarbon dated to roughly 850 to 950 B.P., which is slightly more recent than previously Darl dated components, and later than most would postulate, or perhaps even accept. The occupation was dominated by an extensive scatter of mussel shells (Carpenter et al. 2006). These late dates indicate possible overlap in

time with groups representing the Austin interval of the Late Prehistoric period.

Burned rock middens, thought to have appeared by the Middle Archaic period (Prewitt 1981; Weir 1976), and more likely during the Early Archaic, continue through this period, with their accumulation having peaked perhaps toward the end of the Late Archaic as demonstrated by the radiocarbon dates obtained from burned rock middens (Black and Creel 1997). This peak may be questioned, as the time-transgressive abundance of dates is probably a factor of charcoal preservation. Burned rock middens at Camp Bowie in Brown County were demonstrated to have been used partially during the Late Archaic (Mauldin et al. 2003). Some middens yielded well-defined central pit features or rock ovens (i.e., Ricklis and Collins 1994; Black et al. 1997; Mauldin et al. 2003; Brownlow 2003). Johnson and Goode (1994:34-35) see xeric conditions (i.e., Dry Edwards Interval) during the early part of this period and propose that burned rock midden use increased significantly for the processing of semi-succulents. The Culebra Creek site contained one 35 cm thick by 5 m long burned rock concentration with what the researcher refers to as the remains of a central heating element. However, no direct evidence of the food resource was recovered. This concentration was associated with Montell points dated to 2700 and 2800 B.P. (Nickels et al. 2001).

The 2 m diameter and 15 cm deep rock oven (Feature 9) at 41WM815 was associated with Montell, Castroville, and Lange points. Feature 9 dated to between 2330 and 2540 B.P. (Brownlow 2003). Other than great quantities of burned rock within this oven, lithic debris, broken tools, animal bones, quantities of charcoal, and carbonized eastern camas bulbs were recovered. Many researchers believe that the rock ovens and large middens represent the cooking of bulk plant resources such as sotol and/or lechuguilla that require long periods of heating to make

consumption a possibility. An alternate hypothesis based on the broad distribution of oak trees and burned rock middens is that these features were used to process acorns (Creel 1986, 1991). More recently it has been directly demonstrated through the identification of burned plant parts that geophytes (tubers, bulbs, and roots) were also cooked in burned rock middens (Brownlow 2003; Dering 1997, 1998, 2003; Mauldin et al. 2003; Mehalchick et al. 2004). Chemical residue analysis on burned rocks from a central cooking feature at Mustang Branch midden (41HY209) revealed animal residues (Loy 1994). Other smaller burned rock dumps, scatters, basins, and flat hearths have been recognized at various sites during the Late Archaic period.

Bison may have been one of many resources exploited throughout this time, given that their presence was demonstrated by Dillehay (1974). At 41TG91 bison bones were directly associated with the Marcos points dated to  $2910 \pm 270$  B.P. (Tx-4764B),  $2540 \pm 80$  B.P. (Tx-4764A), and  $2480 \pm 60$  B.P. (Tx-4761, Creel 1990). Bison bones from the Barton site (41HY202) yielded bone collagen radiocarbon dates between about 1800 and 2150 B.P. (Ricklis and Collins 1994). This is the same period during which bison were also present in the Lower Pecos region as evidenced by Bone Bed 3 at Bonfire Shelter, which was associated with Castroville and Montell points at roughly 2800 to 2300 B.P. These examples demonstrate the wide range of bison across at least the western half of Texas during this period. Other than bison, deer continued to be part of the consumed resources as were other riverine resources that included mussels (Baker 1998). The Late Archaic period at Wilson-Leonard (Unit IIIc) also yielded turtle, and small to medium size mammals such as rabbits, carnivores, and raccoons (Baker 1998). A carbon isotope value of  $-17.2\text{‰}$  from a Late Archaic human bone from the Stiver Ranch Burial Sinkhole (41KM140) reflects a diet that consisted predominately of C3

plants and animals that eat these plants (Alvarez 2005).

Kibler and Scott (2000:184) reviewed the distribution pattern of 17 Castroville-Montell-Marcos sites in Camp Bullis, which they believe represent campsites of specialized bison hunting peoples. They discovered that 65 percent of those sites occur in zones with little or no potential for bison. Thus, the distribution of bison may only be part of the explanation for the site selection/distribution.

Cemeteries were in use in central Texas during the Late Archaic as indicated by sites like Olmos Dam (41BX1) with some, if not all 13 burials attributed to this period (Lukowski 1988). Minimally two infant burials, at least one flexed and associated with grave inclusions, that included whitetail deer antlers, traces of ocher, and chert cobbles, were associated with charcoal radiocarbon dates of  $2200 \pm 70$  B.P. (Tx-3989) and  $1920 \pm 160$  B.P. (Tx-3993). The remains of many individuals, possibly up to 200, were recovered from the vertical shaft of Hitzfelder Cave (41BX26), which also yielded a number of Late Archaic dart points (Pedernales, Frio, and Marshall), that in all likelihood were associated with some of the interred bodies (Collins 1970). Sinkholes were also used to deposit Late Archaic bodies as indicated by the Stiver Ranch Burial Sinkhole site, 41KM140. There, one body was radiocarbon dated to  $2130 \pm 40$  B.P. (Alvarez 2005). Isolated burials are also present, as indicated by a semiflexed male skeleton buried 2.2 m deep in an alluvial terrace in Llano County (Bement 1993). This body was associated with a complete Ensor dart point near the dorsal side of the spine opposite the lower thoracic vertebrae, which might have been the cause of death. At Bessie Kruze (41WM13) a small burial pit yielded evidence of three commingled bodies in secondary context that probably were killed by Pedernales points at ca. 3400 B.P. (Johnston 2000). Minimally one of the individuals suffered from systematic infection,

although the teeth were free of caries and showed no abscesses in individuals less than 35 years old (Steele 2000). An individual burial at the Carpenter Bend site (41TV2242) was recovered from along the Colorado River in Travis County (Malof and Taylor 2011). This tall-statured (183 cm) male of old age was radiocarbon dated to  $1350 \pm 40$  B.P. or A.D. 560 to 640. Two Darl points were found on the surface in the vicinity of the burial.

This individual was in relative good health and had successfully adapted to his environment. The C13/C12 ratio of the bones was -18.3‰ that indicates a diet of inland plant and animals resources. He suffered from chronic degenerative conditions derived from extreme dental wear (Malof and Taylor 2011).

During the latter part of this period, broad regional interactions are manifested in a variety of artifacts, such as obsidian, boat stones, two-hole stone gorgets, and marine whelk shells. As an example, an obsidian flake from the Bessie Kruse site in Williamson County was sourced to Polvadera Peak in northern New Mexico (Hester et al. 2000). Johnston and Goode (1994:37-38) describe a number of sites and artifacts from the region that they believe reflect the exchange of items across broad regions. Apparently some long distant exchange networks were in operation during this time.

The Late Archaic is viewed as a continuation of a generalized adaptive strategy that included bison and other diverse plant food resources. Also, population densities apparently increased from the preceding period (Prewitt 1985; Weir 1976).

### **3.6 THE LATE PREHISTORIC PERIOD IN CENTRAL TEXAS**

In the Central Texas Archeological Region, the Late Prehistoric period dates roughly from 1300 to 300 B.P. This period is primarily recognized by the introduction of the bow and arrow, and later on, the

introduction of ceramic technology. The period is divided into two subperiods, early and late, which correspond to the Austin and Toyah “phases” or “intervals,” respectively (Collins 1995, 2004).

#### **3.6.1 The Austin Interval**

The earlier Austin interval, characterized by Scallorn and Granbury arrow points, lacks pottery and, generally, lifeways were similar to those of the preceding Archaic. Where good stratigraphy and context exists at sites that contain both intervals, the Austin material is below, and older than, the Toyah. However, some radiocarbon dates overlap in time, in some parts of Texas (e.g., Quigg et al. 2011b). This may indicate that these two groups potentially were present in the region at the same time (Prewitt 1982b). In fact, violence and conflict are recognized, as a number of burials contain various point types in contexts that indicate they were the cause of death (Prewitt 1981). Perhaps intergroup conflicts underlay a decrease in population, as suggested by Prewitt (1985:218). Contact probably occurred with coastal groups as the bodies interred at Loeve-Fox were associated with conch shell pendants (Prewitt 1982a, 1982b) (Figure 3-6). Radiocarbon dates from Loeve-Fox indicate a period between 1300 and 700 B.P. (Prewitt 1982b).

Data recovery excavations at the J. B. White site (41MM341) in Milam County (see Figure 3-6) further reinforced the age of the Austin interval from about 1350 to 650 B.P. (Gadus et al. 2006). The J. B. White site on Little River along the eastern border of the Blackland Prairie and western margin of the Oak Woodlands, presents solid evidence for a diverse subsistence base during the Austin interval. That subsistence base includes resources from all environmental zones, which reflect a broad-based subsistence orientation. Interestingly, no bison remains were identified (Gadus et al. 2006).

The artifact assemblage consists of formal and informal chipped stone tools, groundstone, and

bone tools. Scattered burned rocks and small burned rock features were present, which indicates continuation of heating and cooking with hot rocks.

Although two projectile point types, Scallorn and Granbury, are linked to the Austin interval, some uncertainty exists as to where the Edwards arrow points belong. Prewitt (1981) does not mention the Edwards type in his central Texas chronology. However, the Edwards type was defined by Sollberger in 1967 (1971) stemming from excavations in rockshelters and burned rock mounds in Kerr County of central Texas. Hester (1978) sees the Edwards type as the earliest arrow point form in southwestern Edwards Plateau. This is based on radiocarbon dates from the La Jita site (41UV28) in Uvalde County that are around 1000 B.P. Their stratigraphic occurrence is primarily below other arrow point types. Prewitt (1995) suggests that Edwards points are primarily distributed across most of south Texas and into the central Texas region, with some recovered in the Trans-Pecos region.

The Rainey site (41BN33) in Bandera County (see Figure 3-6) reveals one of the few well-stratified Late Prehistoric sites with multiple discrete presences of Edwards points below Perdiz points. Sometimes an Edwards point was associated with Scallorn and Sabinal points (Henderson 2001). Multiple radiocarbon dates on charcoal from the Rainey site provide ages for the Edwards points around 900 to 1000 B.P. Two dates associated with Perdiz occupations (Zone IVe) reveal ages between 670 and 790 B.P. These ages are some of the earliest for Toyah occupations in the region. Above this dated zone was evidence for more recent Perdiz occupations (Zones III, IVa, IVb, IVc, and IVd).

### **3.6.2 The Toyah Interval**

The Toyah archeological manifestation is represented by many sites scattered across a broad area of Texas, except for the Texas panhandle region (i.e., Arnn 2012a; Boyd 2012; Kenmotsu and

Boyd 2012; Prewitt 1995:126). Most excavated Toyah sites probably were short-term camps that focused on limited activities such as meat processing (e.g., the Mustang Branch site Terrace [Ricklis 1994]), tool production (e.g., Barton site North [Ricklis 1994]), possible plant processing (e.g., Toyah Bluff site [Karbula 2003]), and bone grease/pemmican processing (e.g., Rush site [Quigg and Peck 1995; Quigg 1997]), although a few basecamps have been identified (e.g., Little Paint [Carpenter et al. 2012]). Toyah materials are primarily dated to between 650 and 300 B.P. (Prewitt 1981, 1985; Creel 1990; Treece et al. 1993b; Johnson 1994; Ricklis 1994; Quigg and Peck 1995; Karbula 2003; Carpenter et al. 2012; Kenmotsu and Boyd 2012), with a few exceptions as noted above.

The Toyah material assemblage consists of a constellation of items that include large thin bifaces, two and four-beveled Harahey knives, Perdiz arrow points, what most refer to as arrow point preforms (Cliffton points), end scrapers, flake drills, prismatic blades, utilized and edge-modified flakes, spokeshaves, choppers/mullers, hammerstones, and plain bone-tempered pottery (Arnn 2012a; Carpenter et al. 2012; Collins 1995; Johnson 1994). Large stone slabs have also been recovered from campsites, and their context and associations indicate use as anvils and/or butcher blocks in the processing of meat products (Quigg and Peck 1995). Grinding implements, metates, manos, and abrading stones are present at many sites (i.e., Johnson 1994).

A soapstone pipe was recovered from 41TG91 (Creel 1990), and a bone-tempered ceramic pipe was recovered from Mustang Branch (Ricklis 1994). An unusual bone-tempered ceramic figurine-like object was recovered from the Varga site (Quigg et al. 2007b). Other types of items include bone beads and awls, various bone tools, antler sections, and mussel shell pendants and beads

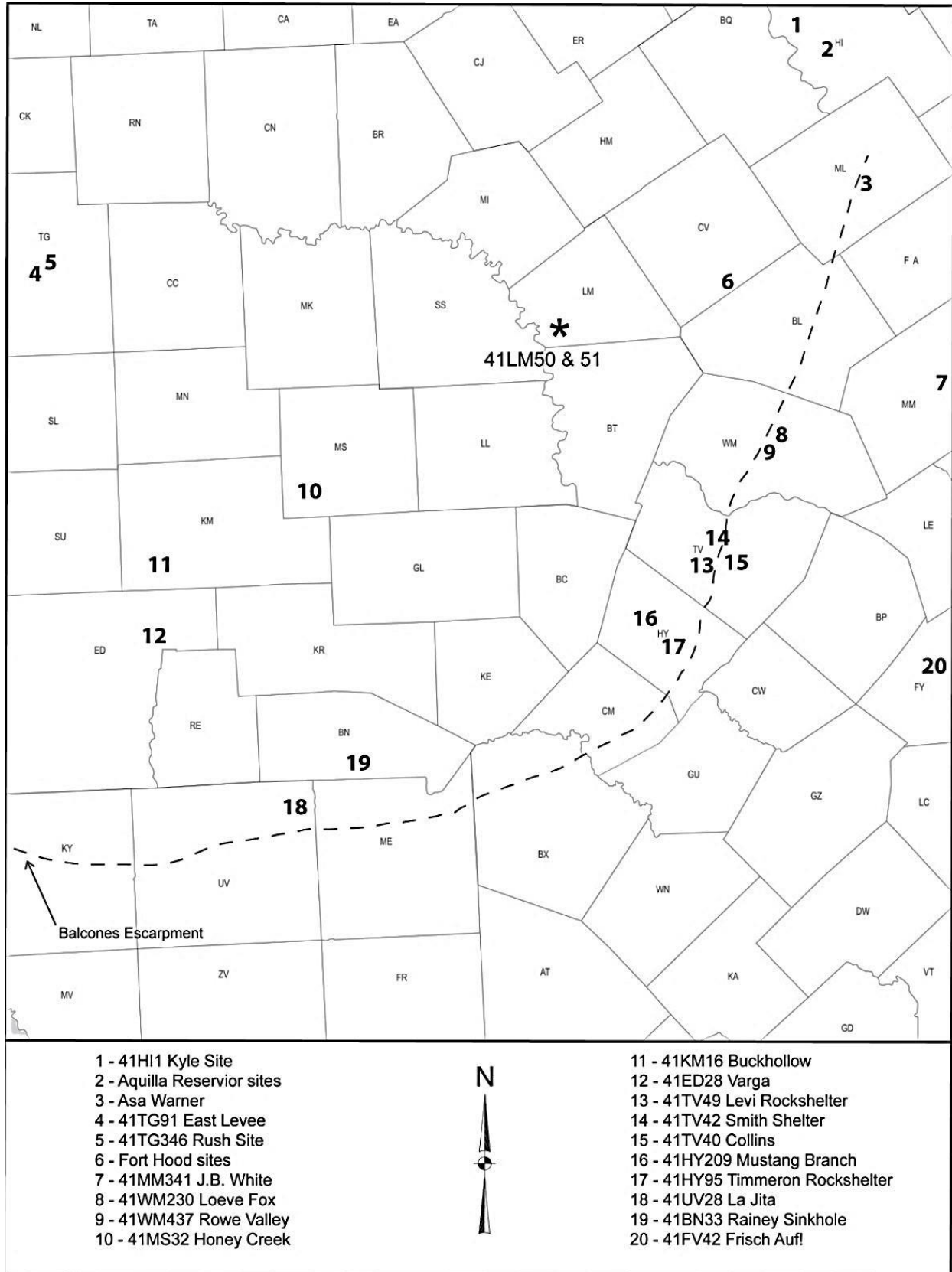


Figure 3-6. Selected Late Prehistoric sites in central Texas.

(Prewitt 1981; Creel 1990; Treece et al. 1993b; Johnson 1994). Exotic goods are rare in Toyah sites, but indicate alliances and contacts with neighboring peoples (Kibler 2012).

Cliffton points (Suhm et al. 1954) are present in most Toyah assemblages and most often referred to as unfinished points or preforms for the Perdiz point (Turner and Hester 1993; Johnson 1994). The apparent impact breaks on some specimens hint that some specimens were finished tools that served as projectile points. Use-wear studies on four Cliffton points from Varga (41ED28) indicate all four were hafted (Hardy 2007) and served as finished tools (Quigg et al. 2007b).

In several sites (e.g., 41TG91 and 41TG346) along the northwestern region of Texas, a small number of different arrow point types occur in direct association with the more frequent Perdiz points. These include Harrell, Lott, and Garza arrow points (Boyd 2012; Creel 1990; Quigg and Peck 1995). Johnson (1994:91-93) illustrates several small triangular specimens that he refers to as preforms for notched arrow points. The presence of multiple point types may indicate interactions with different groups, if you believe that projectile points equate to groups. Boyd (2012) discusses the possibility that sites in the northwestern end of the Edwards Plateau may represent part of the Toyah interval. The stone tool assemblage appears to represent a core-blade industry (Bond 1978; Ricklis and Collins 1994; see Carpenter et al. 2012 for an opposing view). Cores are most often largely unidirectional with more or less flat platforms. Apparently, by-products of biface manufacture—the flakes were selected for production of arrow points (Ricklis 1994:236), and undoubtedly various other tools as well. This is an interesting adaptive pattern and generally reflects conservative and efficient use of the raw material. If a conservative adaptation, it was not out of necessity, as the central Texas region is a chert rich area with natural chert readily available.

Bone tools have also been recovered from many Toyah sites, although not in large quantities. These bone items include tool classes such as awls, flakers, needles, beads, and various shaped and worked bone pieces (i.e., Jelks 1962; Creel 1990; Treece et al. 1993b; Johnson 1994; Ricklis and Collins 1994; Quigg and Peck 1995).

Pottery has been associated with Toyah components since its discovery at the Collins (Suhm 1955) and Smith (Suhm 1957) sites. In Prewitt's (1981) earlier synthesis, he referred to the pottery both as Leon Plain and Doss Redware. Johnson (1994) states these two type names are outdated and collectively refers to Toyah ceramics not by name, but in terms of attributes (i.e., thin-walled, often smoothed with a flat wide stick or cane instrument with fine crushed bone as additives to the fine clays). The exterior colors vary from a light-colored reddish-tan, orange, or brown, and have unpainted surfaces. Wide-mouthed bowls and relatively deep jars are recognized, with some bowls exhibiting a distinctive matte-finish wash on the interiors. Slips are occasionally present. Rims are usually thin and beveled on their inside edges. The additives to the natural clay are dominated by tiny burned and calcined bone pieces, but limited quantities of quartz sand and other particles have been detected as well (Reese-Taylor 1993, 1995; Robinson 1999, 2007).

At present, we are no closer to determining where this ceramic technology originated. Johnson (1994:287) believes the observed attributes point to source regions in U.S. Southwest or northeastern Mexico, although he cannot rule out the Southern Plains region. The bone-tempering technology probably had its origin in the Caddoan region of northeast Texas.

The frequency of ceramic sherds and the projected number of vessels varies considerably at Toyah sites. As an example, 480 sherds were recovered from Mustang Branch (41HY209) and probably represent five distinct vessels (Ricklis 1994). At the

Rush site (41TG346), only 184 sherds were recovered from Occupation 4, and represent minimally seven vessels (Quigg and Peck 1995). These relatively low numbers indicate that few ceramic vessels were at most Toyah sites. Therefore, it should not be surprising that some Toyah sites do not yield ceramic sherds.

Interactions with other groups are also indicated in the ceramic assemblage as brushed and/or incised exterior surfaces of vessels similar to Caddoan types have been recovered in low numbers at several Toyah sites (Jelks 1962; Johnson 1994; Pertulla et al. 2003; Quigg and Peck 1995; Ricklis 1994; Suhm 1955, 1957). However, the easily recognized painted trade vessels from the southwestern part of the U.S. have not been detected in any Toyah components thus far. The absence of Southwest trade sherds coupled with the often present Caddoan sherds indicates the primary direction of interactions of the Toyah groups was to the northeast. This may be a reflection of the close proximity of the Caddo area to the Toyah area, since hundreds of kilometers separate the Toyah area from the Jornada Mogollon area.

Despite only a few petrographic and other source studies on Toyah ceramics (Kittleman 1994; Pertulla et al. 2003; Reese-Taylor 1993, 1995; Reese-Taylor et al. 1994; Robinson 1999, 2007), Johnson (1994) stated pottery did not often move across drainage systems. Petrographic analysis on seven sherds from San Felipe Springs (41VV444) (Mehlich et al. 1999; Robinson 1999) and previous petrographic analysis on nine sherds from Infierno sites (Turpin and Robinson 1998), all in Val Verde County, were compared (Robinson 1999). At the petrographic level, Robinson (1999) sees fundamental technological similarities with only minor, regional variations in the matrix, but sees no distinctive or even subtle differences between the Infierno and Toyah phase pottery from San Felipe Springs. The regional variations probably represent different ceramic production localities (Robinson 2007).

A large instrumental neutron activation analysis (INAA) was completed on a variety of Late Prehistoric pottery sherds collected from many Late Prehistoric sites across the southwestern and central part of Texas. The results of the INAA on the sample of nearly 400 sherds reveal six compositional groups, and provide some interesting geographical distributions (Creel and Johnson 2002). An INAA analysis on a sample of Toyah ceramics from the Varga site in Edwards County reveals limited similarities to the Central Texas-1 and -2 reference groups. The Edwards County sample has less than a four percent probability of membership in either of these two compositional groups (Speakman and Glascock 2007). The differences in paste, reflects insights into pottery production localities and movement of vessels across the landscape. Minimally one, and probably two vessels, were manufactured from local clays (Quigg et al. 2007b). Another INA study of 27 plain and Caddoan-style sherds from Fort Hood in Coryell County reveals most sherds probably had Caddoan origins (Pertulla et al. 2003). These imported vessels reflect interactions between northeast Texas Caddoan farmers and central Texas hunter-gathers along the Balcones Escarpment.

Chemical analyses (i.e., of fatty acids) on sherds have been infrequent, but have yielded animal lipids that indicate vessels were used to cook meat products (Loy 1994). In contrast, plant lipids were identified on the shreds from the Toyah component at the Varga site (Malainey and Maliszka 2007). Stable carbon and nitrogen isotope analyses on residues extracted from these same sherds have also indicated vessels were used in cooking meat products, which included bone grease (Quigg and Peck 1995), plus various plant resources (Quigg et al. 2007b).

Burned rock features that include large and small hearths, rock lined and filled hearths, burned rock dumps, and minimally one large burned rock midden (Honey Creek Midden at 41MS32) have



been attributed to the Toyah period (Black and Creel 1997). Black and Creel (1997) demonstrated through compilation of radiocarbon dates from burned rock middens that these middens were continually used through the Late Prehistoric period. Most archeologists do not see the larger burned rock middens as part of the Toyah interval, although often a Toyah component lies directly on top of a burned rock midden deposit, as reflected at Mustang Branch (Ricklis and Collins 1994; see Black et al. 1997 for different view).

A limited number of burned rocks have been subjected to chemical residue (i.e., fatty acids) analyses. The few fatty acid results support their use in cooking meat (Loy 1994) and plants (Malainey and Malisza 2007). Various other features identified include ash, charcoal and bone concentrations; bison rib alignments, clay-lined pits, knapping stations, organic stains, oxidized areas, unlined pits, and wall trenches (i.e., Treece et al. 1993b; Quigg and Peck 1995). In at least one instance, the distribution of artifacts around hearths was thought to reflect a large brush-walled windbreak (Johnson 1994:283).

Quantities of animal bones such as bison, deer, and antelope are often associated with the Toyah sites. The faunal remains reflect a human population focused on large game animals (Creel 1990; Shaffer 1994; Ricklis and Collins 1994; Quigg and Peck 1995). This represents a dramatic shift in subsistence from the earlier Austin interval with its broad-based hunting and gathering economy. At the Mustang Branch site, great quantities of bone represents extensive butchering of a minimum of 19 adult deer, 6 fetal deer, 8 antelope, and 2 bison. The presence of this many animals processed at one camp is a testament to group cooperation in the procurement and processing of bulk resources (Masson and Holderby 1994). The highly fragmented condition of bones at sites like Mustang Branch and Rush indicates that bone grease production was also undertaken (Masson and

Holderby 1994; Quigg 1997; Quigg and Peck 1995). The tool assemblage documents the intense procurement, butchering, and processing of animal products.

Although the Toyah groups are portrayed as hunters of large game, they also collected very diverse resources that included river mussels and used these as food (Creel 1990). Fish, turkey, rabbits, and turtles are other probable food resources indicated by their bones at several Toyah sites (Carpenter et al. 2012; Creel 1990; Johnson 1994; Quigg and Peck 1995; Shaffer 1994). Charred mesquite seeds and pods were recovered from the Rush site (Quigg and Peck 1995). The Toyah Bluff site (41TV441) yielded at least 10 onion bulbs from within and adjacent to pit Features 2 and 11 of Block 1 - the proposed Toyah component (Karbula 2003). Because of the diverse food resources recovered from numerous Toyah sites, Dering (2008) and Quigg and Dering (2007) made a strong case for a nonspecialized subsistence base for Toyah interval. Although very late in time, and with agricultural practices underway in the northeastern part of Texas, minimal evidence is available for agricultural crops through a few isolated corncobs (Jelks 1962; Harris 1985). The infrequent cobs at Kyle site (41HI1) (Jelks 1962) and Timmeron Rockshelter (41HY95) (Harris 1985) may represent exchange items very late in the sequence. However, recent starch grain analysis on burned rocks from small burned rock features in Mills County indicate the presence of maize at 980 B.P. (Quigg et al. 2013b).

The Kyle site in Hill County, just north of the Central Texas Archeological Region, yielded perishable material that includes twisted cordage, pieces of mats, and coiled basketry fragments, arrow fragments, notched sticks, pointed sticks, pointed wooden splinters, wood shavings, and pieces of tanned deer skins (Jelks 1962). These perishable goods provide insights to the Toyah culture not available from most open air sites.

Human remains have been found as isolated burials (e.g., Kyle [Jelks 1962]) and in cemeteries (e.g., Loeve-Fox [Prewitt 1974, 1982b]) with interred bodies in various positions. At least 10 cremations have been identified. The burial at Kyle site was a cremation that had been wrapped in an unwoven fiber mat with no mortuary offerings. Several bodies reflect conflict and/or hostilities between groups as different arrow point types such as Perdiz in two flexed bodies at Asa Warner #2 (Watt 1956), as well as Scallorn points embedded in human remains at sites like Loeve-Fox and Frisch Auf! (Hester and Collins 1969; Huebner and Comuzzie 1992; Prewitt 1974).

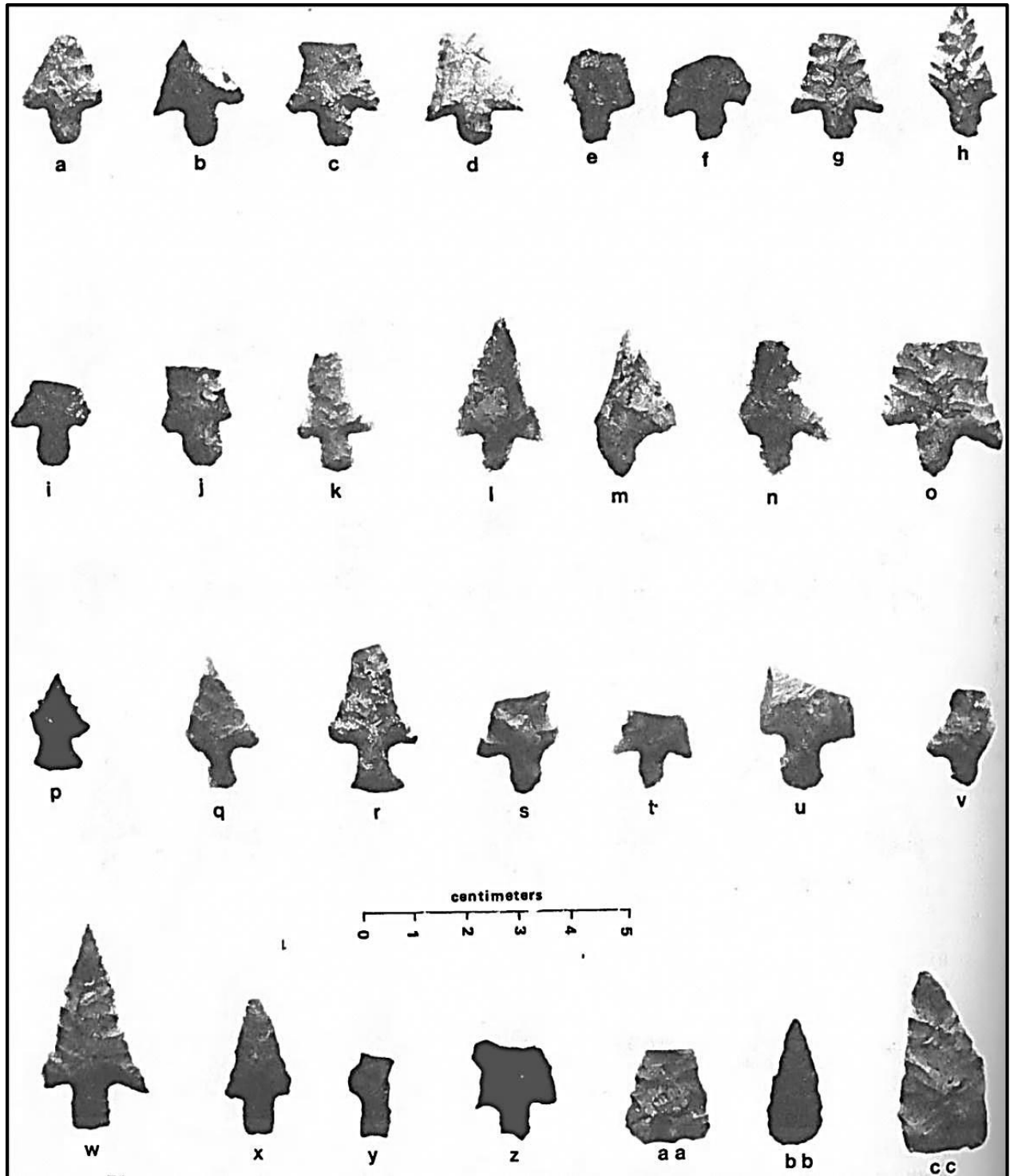
The general perception has been that the Toyah groups represent bison hunters that migrated into the area bringing their own technology and changes in adaptive strategies (Collins 1995, 2004; Johnson 1994; Prewitt 1981, 1985; Ricklis and Collins 1994). The adaptive system involved relatively high subsistence mobility as a correlate of extensive use of large game such as bison, deer, and antelope. However, Johnson (1994:286) believes there is considerable evidence for the conclusion that Classic Toyah communities did not move great distances. He cites use of local clays for vessel, the distribution of two and four-beveled knives, and localized finds of cone-shaped ceramic pipes as his evidence. The wide distribution of Toyah interval assemblages across the Texas landscape opens the debate as to whether or not this represents the spread of ideas or people. Black (1986) and Ricklis (1992a, 1994) see it more as a widely adopted techno-complex, whereas Johnson (1994) sees it as a single ethnic group. Johnson (1994:286) sees an underlying unity among Toyah customs and practices to reflect a common background. He also sees the sudden appearance of the Toyah manifestation as an indication that they were “interlopers”. Ricklis (1992a, 1992b, 1994) points to the presence of the same lithic assemblage along the central coast, where the ceramics, by contrast, are distinctively non-Toyah, and believes this

discrepancy indicates that the lithic assemblage was widely adopted by groups of quite different ethnic/linguistic affiliations. Recently much has been written about the Toyah phase (see Kenmotsu and Boyd 2012; Arnn 2012b; Carpenter et al. 2012) and Carpenter (2012) synthesized Toyah models and revised the model with interpretations of the Toyah origins and identity and placed this into a broader context and discussed macroregional forces.

### **3.6.3 Unassigned Late Prehistoric Components**

The two Late Prehistoric arrow points (Alba and Bonham/Alba-like points) from 41LM50 cannot be assigned to either the Austin or Toyah intervals. Brown et al. (1987a), Story (1990:364), Shafer (2006), and Gadus et al. (2006:177) all recognize that the cultural assemblages of the Late Prehistoric period across east-central Texas prairie region are poorly understood. In fact many sites and components with arrow points from this region cannot be ascribed to either of these two central Texas cultural expressions, as they are currently defined.

The Alba and Bonham/Alba-like arrow points from 41LM50 conform typologically to specimens found at other sites in the east-central Texas prairie region (e.g., Jelks 1962; Brown et al. 1987a, Shafer (2006), Gadus et al. 2006). Their presence hint at linkages to vaguely known or poorly defined Late Prehistoric cultural pattern or patterns. Gadus et al. (2006), in their interpretive discussion of findings at the J. B. White site (41MM341) along the Little River in Milam County, suggest the existence of an indigenous Late Prehistoric cultural pattern characterized by Alba and Bonham arrow points, thin bifacial knives of the Gahagan type, and sparse ceramics. In the J. B. White site assemblage, these authors recognize a possible relationship with the early Caddo culture of east Texas, and suggest the possibilities of either direct or indirect (“down-the-



**Figure 3-7. Late Prehistoric arrow points from the McDonald site.** Note: (a-h) Alba-like Variant I; (i-k) Alba-like Variant II; (l-o) Perdiz; p-r Scallorn; (s-v) Miscellaneous Round Stemmed; (w-z) Miscellaneous Square Stemmed; (aa-cc) Miscellaneous Triangular. (from Brown et al. 1987b:38-90; Figure 38-14).

line”) trade between prairie hunter-gatherers and the agricultural Caddo area, as represented especially by certain types of mortuary artifacts recovered from the early Caddo George C. Davis site. Gadsen et al. (2006) emphasize that, at this point in time, inferences concerning the nature of this Late Prehistoric pattern are tentative, due to a general dearth of data from sites other than J. B. White. Along the northeastern margins of the Central Texas Archeological Region the Late Prehistoric sites are often dominated by Alba and Alba-like arrow points as detected in sites from the Aquilla Lake project in Hill County (Brown et al. 1987a). The McDonald site (41HI105) in Aquilla Lake is a good example of a Late Prehistoric assemblage that contained arrow points classified as Alba and Alba-like along with a number of other arrow points that include Scallorn, Clifton, and Perdiz (Figure 3-7). That Late Prehistoric assemblage also yielded ceramic types (i.e., Kaim Incised and Canton Incised) that are not those generally associated with the Toyah interval, and probably do not represent a manifestation of the

Caddoan ceramic tradition (Brown et al. 1987b:38-109). In general, the radiocarbon dates from these contexts indicate a use period spanning approximately 1,000 years from 1750 to 750 B.P. (ca. A.D. 200 to 1200). These ages are earlier than most Toyah dates and are more in line with the later end only of the Austin interval in central Texas. Apparently other cultural manifestation(s) may account for the occupation represented at 41LM50, since it does not fit well into the currently defined Toyah interval.

In 2006, Harry J. Shafer proposed that Caddo people inhabited the prairie environments of central, east-central, and north-central Texas during the early part of the Late Prehistoric period. He suggested that the area occupied by what he termed the “Southern Prairie Caddo” (Shafer 2006:5) extended from the margins of the east Texas woodlands westward as far as the central part of Lampasas County. This is further discussed in the research design presented below in Chapter 5.0 and again in Chapter 6.0.

*This page intentionally left blank.*

## **4.0 METHODS**

J. Michael Quigg and Paul M. Matchen

### **4.1 INTRODUCTION**

Allen Bettis, then TxDOT staff archeologist for the Brownwood District, previous TxDOT staff archeologist Dr. Mary Jo Galindo, and Mike Quigg, Principal Investigator for Cultural Resources Section of the Planning, Permitting and Licensing Practice of TRC, visited and inspected the APE at the two Lynch Creek Bridge locations on May 25, 2004. The inspection included a general walkover of the existing TxDOT right-of-way and examination of exposures to look for indications of cultural materials. The two planned bridge replacements created four potential localities at each bridge crossing, two on either side of each bridge for a total of eight quadrants which might contain cultural resources. At each crossing the proposed APE consisted of a narrow 10 meters (m) wide temporary easement immediately south of the existing TxDOT right-of-way on private property. TxDOT planned to acquire access to these temporary easements before construction, but the land was still in private ownership and the precise boundaries of the easements were not marked on the ground at the time of the inspection or subsequent investigations. During TRC's inspection, and the subsequent eligibility testing phase, a fence separated the private lands from the existing TxDOT right-of-way. Upon inspection in May 2004, three of the eight potential quadrants adjacent to the two bridges yielded evidence of unrecorded cultural materials. One prehistoric site (41LM51) was at the southeastern quadrant of the western bridge, and two additional prehistoric sites (41LM49 and 41LM51) were at opposite ends of the eastern bridge crossing.

In June 2004 Mr. Bettis conducted a review of the THC Archeological Sites Atlas records. The review indicated that no cultural resource sites had been

previously recorded in these two proposed bridge construction localities. Following the May 2004 field inspection and site file search, Mr. Bettis completed an Archeological Impact Evaluation report in June 2004 for each proposed bridge structure location. In his two reports, Mr. Bettis recommended eligibility testing at the three newly discovered prehistoric sites, all with buried cultural materials.

Following THC determination that further work was necessary for the three prehistoric sites, a strategy/plan for the archeological testing program was devised to record, document and assess these three site locations. The strategy used knowledge gathered from the May 2004 inspection and finalized during a subsequent meeting at TxDOT Austin office between TRC's Principal Investigator and TxDOT staff members of the Archeological Studies Program in Austin. These three newly discovered cultural resource sites were subsequently designated TARL as 41LM49, 41LM50, and 41LM51.

In the following sections, the general field methods for the entire project are presented. The presentation of the general field methods is followed by a discussion of the laboratory procedures and technical analyses that documented the materials recovered. Lastly, curation of the materials is presented. Site specific field methods are presented by site in subsequent chapters.

### **4.2 GENERAL FIELD METHODS**

Once the TRC crew was in the field, the first step was to create a sketch map of the location depicting the existing right-of-way, the proposed APE, overstory vegetation boundaries, key site characteristics, and the location of the observed cultural materials. As work progressed, additional information was added to the sketch maps, such as the location of the test units and trenches. All three site locations contained Holocene alluvial deposits

with exposed stream cutbanks. Given the presence of deep alluvium, mechanical trenches were excavated at each site (Figure 4-1). The limited access to the narrow APE restricted the number and location of backhoe work in the proposed easements. The TxDOT Brownwood District office provided the backhoe and operator.

A total of six trenches that encompassed some 43 linear meters were excavated during this project. Trenches were positioned within the existing TxDOT right-of-way at 41LM49 and 41LM51. At site 41LM50, a private gate in the fence allowed backhoe access directly to the proposed easement. The excavated trenches provided deeper, broader, and cleaner exposures into the subsurface than shovel tests could provide, which allowed the geoarcheologist to identify the nature of the depositional sequences at specific locations. After excavated, trench walls were hand-troweled, inspected for subsurface cultural materials, any cultural materials encountered were documented, and samples collected. The geoarcheologist, Dr. Charles Frederick, and TRC archeologist Mike Quigg inspected the trench walls. Dr. Frederick documented the deposits observed in each trench (Figure 4-2); see Chapter 7.0 for details and interpretations, and Appendix A for trench descriptions). Selected trench exposures were sampled for charcoal and/or sediment for potential radiocarbon dating, with further documentation and additional collection of certain cultural materials (i.e., at 41LM49). The depositional context recorded also provided insights to the integrity of the cultural deposits.

Following trench excavation, inspection, and documentation, 1-by-1 m hand-excavation test units (TUs) were placed across the APEs. Test units were horizontally distributed to sample the length and width of the proposed APEs. They were employed to investigate and assess the deposits for buried cultural materials. Test units were numbered sequentially by site. A total of 21 hand-excavated



**Figure 4-1. Example of trench excavation at sites.**



**Figure 4-2. Charles Frederick documenting soils in test unit profiles at 41LM51.**

units, which totaled 17.2 m<sup>3</sup>, were completed in the three sites collectively.

These units were excavated from the existing ground surface and generally penetrated below the lowest cultural component detected by the trench excavations, or into Pleistocene age deposits. TUs were excavated into alluvial deposits in 10-cm arbitrary levels. Excavation depth measurements were taken in centimeters from below surface (cmbs). Hand-excavated sediments were screened through 0.64 cm (1/4 in.) hardware cloth. An excavation level record form was completed for each hand-excavated and screened level.

These level forms document provenience information, depth excavated, excavation techniques employed, observations concerning sediment types encountered, and types and quantities of cultural materials recovered from that level.

When clusters of cultural material designated as features or sizeable pieces of cultural material (generally 5 cm or greater), were encountered *in situ*, these items were piece-plotted on the excavation level records and the bottom elevations were recorded. Recovered cultural materials (except for burned rocks, see below) were bagged by material classes in resealable plastic bags by test unit and level, and a paper tag with appropriate provenience information was completed and placed in each bag. These bags were boxed and transported to TRC's laboratory in Austin for check-in, processing, and analysis.

Recovered burned rocks were generally sorted into four previously established size categories (i.e., 0 to 4 cm, 4.1 to 9 cm, 9.1 to 15 cm, and greater than 15 cm), counted and weighed by size class in the field, recorded on each level record, and then often discarded in the field. Samples of burned rocks from selected features and non-feature contexts were collected, bagged, and transported to the Austin laboratory for possible additional analyses.

Bulk sediment, macrobotanical, charcoal, phytolith, and other samples were collected as deemed necessary by the Principal Investigator, with the primary goals of determining the age of site deposits and recovering data pertinent to addressing research questions. Samples included a random sampling of the natural chert gravels from upland terrace settings east of 41LM51 and west of 41LM50. These collections were in anticipation of conducting instrumental neutron activation analysis on and comparing to the archeological assemblages collected.

Outsourced technical analyses (e.g.; radiocarbon dating, assessing matrix for phytoliths, and identification of macrobotanical remains), were anticipated to help determine and refine the data content of site deposits, assess contextual integrity of those deposits, and address broad research questions about the chronology and nature of occupation(s) at each site.

Following fieldwork, State of Texas Archeological Site Data Forms were electronically completed for all three sites and copies were submitted to TARL in Austin for review and assignment of trinomial numbers. TARL-assigned site numbers were then applied to materials collected from each respective site. Electronic databases of collections by site were created using Microsoft Access with sequential lot numbers assigned as artifacts were checked in. Recovered artifacts from each site (including chipped and ground stone tools, faunal bones, lithic debitage, and mussel shells) were sorted by material type, washed, labeled with site and lot numbers, counted, analyzed as necessary, and prepared for curation. Cultural materials and samples were temporarily curated at TRC's laboratory facilities in Austin, Texas. Following completion of analyses and reporting, cultural materials and samples shall be permanently curated.

Prior to completion of the interim report (Quigg and Frederick 2005), specific samples from each site were selected for analyses by outside technical experts in order to extract information helpful in assessment of the significance of the sites. TRC selected radiocarbon samples and provided justifications to TxDOT, then once approved by TxDOT personnel, 12 samples (8 *Rabdotus* samples, 3 chunks of charcoal, and 1 faunal bone) plus the completed radiocarbon laboratory forms for each sample were delivered to TxDOT, and subsequently sent to University of Georgia (UGA) Center for Applied Isotope Studies (CAIS), for radiocarbon dating. The UGA laboratory results are presented in Appendix B. Seventeen



macrobotanical samples were selected and sent to Dr. Phil Dering of Shumla Archeobotanical Services in Comstock, Texas for identification and assessment of potential further information. Dr. Dering's results and conclusions are presented in Appendix H. Six sediment samples were selected and submitted to Dr. Steven Bozarth in Lawrence, Kansas, for presence/absence assessments of phytoliths to determine their potential to address and reconstruct site paleoenvironment. Dr. Bozarth's results, comments, and interpretations are presented in Appendix E.

### 4.3 LABORATORY PROCEDURES AND TECHNICAL ANALYSES

All provenience information available and any pertinent data from level records or collection bags were entered into a Microsoft Access format database at initial artifact check-in. TRC's cataloging system assigns strings of numbers to artifacts that encode, as a unique identifier, information on provenience, artifact class, as well as denoting any samples taken from the artifact(s) for specialized analyses. All cultural materials were assigned Provenience Numbers (PNUMs) by site and entered into an electronic database. These unique PNUMs (e.g., #250) were assigned to individual excavation levels, as well as any additional provenience, such as feature designations. PNUMs are sequential integers that designate the overall provenience unit (i.e., excavation unit, backhoe trench, modern ground surface) level and/or depth, within that provenience unit, and can be cross referenced to a master list of PNUMs.

Within each PNUM, various artifact classes were assigned a secondary designation referred to as the artifact category number: lithic debitage (001), faunal bone (002), burned rock (003), soil samples (004), feature (005), shell (006), macrobotanical remains (007), ceramic sherds (008), and historic material (009). Unique items, such as tools, were

assigned individual artifact identifiers by test unit and level, starting with the number 10 and increasing sequentially as needed. Therefore, individual tools were assigned a PNUM and an individual unique number appended to the PNUM (e.g., #250-10, #250-11, and #250-12).

Laboratory artifact processing included the initial check-in, sorting as necessary, and assignment of PNUMs by site. With the exception of burned rocks and mussel shells, most cultural materials were washed and labeled, although a few specific artifacts remained unwashed for potential further analysis. Before washing, all bags of lithic debitage were examined for both formal and informal tools, including flakes with modified edges. All identified stone tools were handled with nitrile gloves, bagged separately, and only cleaned where necessary in order to apply the archivally stable provenience number/label.

In selected instances, individual burned rocks were removed from the collection for specialized analyses that included radiocarbon dating, lipid residue, and starch grain analysis. After a particular burned rock was selected for analyses, it was broken into multiple pieces, and parts of that individual rock were then sent for each type of analysis. For example, if a particular burned rock was selected from the collected burned rocks from #250-003 for starch grain analysis, then that burned rock would be designated as #250-003-1 to indicate it constituted the first sample from that burned rock group. In another words, the catalog number #250-003-1 would identify that specific burned rock as the first sample (#1) taken from the burned rock class of artifacts (003) within a specific provenience unit (#250). If burned rock #250-003-1 was subdivided into two pieces for two different types of analyses, such as lipid residue and starch grain analyses, then lower case letter designations (e.g., a and b) would be added after the last number in the sequence (i.e., #250-003-1a and #250-003-1b) to signify that two parts (part a and b) were

taken from burned rock #250-003-1. The complete two- or three-part number sequence assigned to each object or class of objects constitutes the accession number. This process allows individual pieces of large collections of various materials to be individually handled and tracked without the risk of a loss of provenience information.

About one in ten items (10 percent) in bulk material classes (e.g., chert debitage, mussel shells, faunal bones) within specific provenience units (e.g., a level) were individually labeled as per Council of Texas (CTA) curation guidelines (<http://counciloftexasarcheologists.org/>). Specimen size was also a major consideration for labeling purposes, as many lithic pieces are less than 1 cm in diameter and were not labeled. Artifact labeling consisted of inscribing the State of Texas Archeological Site Trinomial (41LM49, or 41LM50, or 41LM51) and the PNUM number on designated artifacts using black indelible ink. After the ink was dry, the artifact labels were coated with clear Acryloid B-72 with reagent-grade acetone solvent to preserve the inscriptions.

Permanent paper tags were included with each individually bagged artifact or class of artifacts collected from a single provenience. These tags have the site trinomial, provenience information (test unit and depth), the class or type of artifact(s), the date of excavation, the excavator's initials, and the quantity of items in the bag. These permanent tags were printed on acid-free, 30.4 kg (67 lb.) card stock and filled out with pencil.

#### **4.3.1 Analytical Methods**

Artifacts were subjected to different metric, nonmetric, typological, and specialized analyses, such as starch grain and high-powered microscopic use-wear analysis. A set of predefined attributes for each material class were first encoded on paper, and then entered into TRC's electronic database management system that utilized Microsoft Access 2010 software, which constitutes the master

database for each of the three investigated sites. A copy of these three databases is provided on the CD-ROM attached to the back cover of this report. The specific data recorded for each class of artifact are presented below. Analytical methods pertinent to each data class are discussed in detail in the appropriate parts of this report.

##### **4.3.1.1 Chipped Stone Artifact Analysis**

A protocol for analysis of lithic debitage and chipped stone tools has been developed by TxDOT archeological staff in an effort to standardize data collection and presentation in analytical and interpretive chapters of archeological reports sponsored by TxDOT (TxDOT 2010). Terminological and taxonomic uses follow those terms for the detailed analysis of selected assemblages (Figure 4-3). When discussing assemblages in general and in part of the experimental analysis plus those not subjected to detailed analysis using the TxDOT protocols, other more familiar terms were used.

##### ***Bifaces***

Bifacial tools, whether finely or crudely produced, represent different stages of reduction to target an idealized trajectory. Bifaces are generally referenced to as stages of reduction starting with a blank (Stage 1) followed by blank preparation by lateral edge refinement (Stage 2), followed by preform shaping and thinning (Stage 3), then final edge trimming and shaping (Stage 4), and Stage 5 is the rejuvenation of previous forms (TxDOT 2010).

Most or all of both faces may be covered with flake scars, and in some instances one face may be completely modified, whereas the opposite face may exhibit only partial modification. Bifaces may be fashioned either from large bifacial cores or from flakes. Included within this overall morphological category are diverse functional groups such as projectile points (see below).

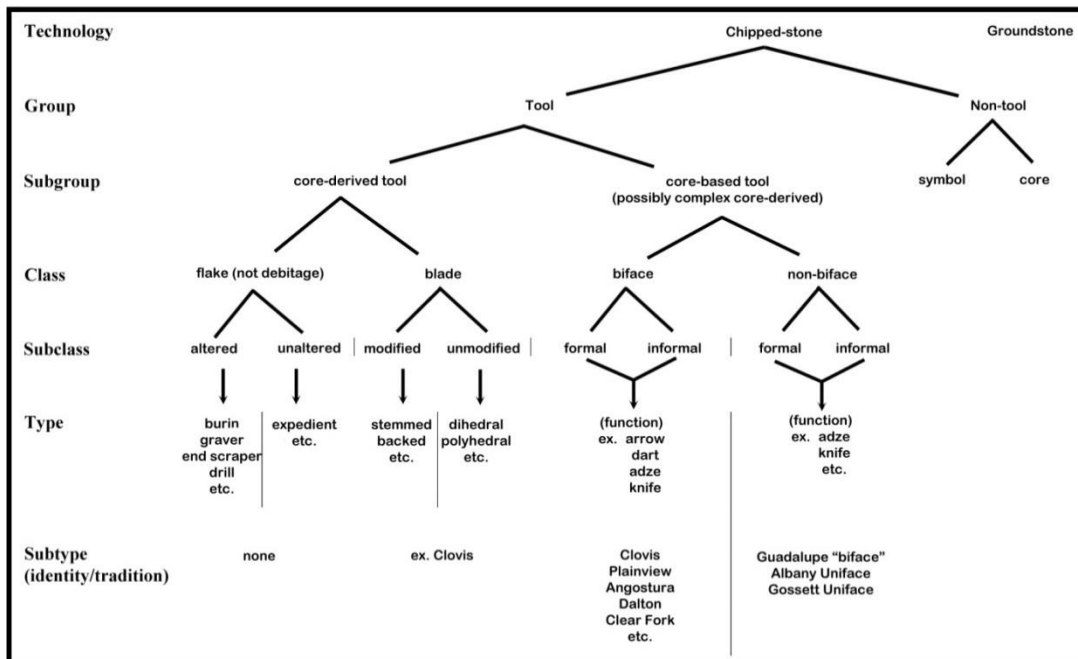


Figure 4-3. Chipped stone artifact analysis flowchart.

### ***Projectile Points***

Projectile points are a functional subset of the biface class specifically designed to be hafted to the distal end of a shaft used in stabbing, throwing, or shooting to penetrate animal hides and flesh and kill the animal. Projectile points are bifacial tools given their final form by means of fine secondary retouch, usually with basal modification in the form of notching, stemming, or thinning of the proximal end for purposes of hafting. Dart points, arrow points, and indeterminate dart/arrow points are all classes of projectile points. Dart points were those employed to tip hand-held darts or spears, arrow points were used to tip arrows, and indeterminate points are, as the name implies, of uncertain usage. Whereas dart points were usually manufactured from bifacial preforms, arrow points were often manufactured on thin flakes.

Projectile points were assigned to recognized types whenever possible. In traditional archeological literature, projectile points are normally referred to by their typological designation, which are usually based on a set of morphological characteristics, shared in common by groups of similar points,

which generally focus on haft modification. Point classifications were conducted by TRC's personnel in reference to established point typologies in use in Texas archeology (Suhm and Jelks 1962; Turner and Hester 1993; Turner et al. 2011). Many tools identified as "points" served entirely or situationally as knives.

### ***Unifaces***

Unifaces are those tools that exhibit flake scars on one face only. Like bifaces, unifaces are defined based predominantly on morphological characteristics, but they also tend to have functional associations (e.g., scraping, planing, cutting, engraving). Unifacial tools exhibit purposeful flaking across most or all of one face, whereas the opposite face most often remains flat and unmodified. Unifaces may be fashioned from cobbles or flakes and include such functionally diverse groups as scrapers, gouges, edge-modified flakes, gravers, and spokeshaves. One or more edges of a unifacial tool may exhibit manufacture and/or use-related flake removals that may be patterned or random. To some degree, unifacial tools form a continuum that range from formal

tools, which exhibit intentional, patterned, and manufacture-related edge flaking to informal, expedient tools that show only use-related edge scarring. The former tend to fall in the scraper and gouge categories, whereas the latter are generally classified as edge-modified flakes.

### ***Scrapers***

Scrapers are a specific type of unifacial tool that have minimally one intentionally modified working edge. In some instances, bifacial modification may be present, but in such instances the intentional retouch tends to be located on the dorsal flake surface whereas the ventral surface tends to exhibit primarily use-related flake scars. Based upon the location of the primary working edge, scrapers are subdivided into end, side, or combination types. End scrapers are pieces with retouch, restricted primarily to either the distal or proximal end of the flake blank, generally producing a convex working edge. The opposing end of the piece may bear some minimal retouch, presumably to facilitate hafting. Side scrapers are pieces with retouch present on one or both lateral edges of the flake blank. Working edges may be convex, straight, or concave. On combination scrapers, marginal retouch may appear along the end as well as along one or more lateral edges of the blank. As implied by the name of this tool, the primary function of scrapers is presumed to relate to scraping relatively soft materials such as animal hides or vegetable matter, or slightly harder materials, such as wood or possibly antler or bone.

Twenty-eight metric and nonmetric attributes were recorded for scrapers. Many measurements relate to the number, location, and characteristics of the worked edges. Metric measurements of length, width, thickness, and weight were recorded for each specimen even if it was broken.

### ***Edge-Modified Flakes***

Edge-modified flakes are minimally modified flakes, flake fragments, or pieces of angular debris

that are characterized by one or more areas of flake scarring along margins. The edge flaking may be patterned or unpatterned, continuous or discontinuous, and may result from use-related activities or from intentional pressure retouch to prepare an edge for use. Many edge-modified flake tools exhibit combinations of these characteristics, and many have more than one worked edge. The modifications, however, usually are restricted to the edges of the piece and do not significantly alter the original flake form. Such edge modifications may be either unifacial or bifacial. Edge-modified flakes are usually considered ‘expedient’ tools, pieces of raw or minimally modified material that are utilized for a short time, and subsequently discarded soon after use.

### **4.3.1.2 Lithic Debitage Analyses**

Chipped stone or lithic debitage is unmodified debris resulting from stone tool manufacture and maintenance. During the analysis process, the laboratory technician uses macroscopic analysis for flake or use scars that indicate modification on each flake to separate any possible tools. All debitage from all test units was counted and most subjected to detailed analysis to understand the general character of each site debris assemblage. The debitage analysis at 41LM50 targeted only the Late Prehistoric component in the top 30 cm of the deposits. The debitage analysis at 41LM51 targeted the Late Prehistoric probable Toyah component in the 20 to 40 cmbs and the probable Gower component between 80 and 110 cmbs in the lower part of the T<sub>0</sub> deposits. The Late Archaic component in T<sub>2</sub> terrace was subjected to sampling and targeted the levels in two units with the two burned rock features present. This unit and level was selected because it contained a high frequency of archeological material.

Selected tools and much of the lithic debitage were also examined under ultraviolet (UV) light to isolate raw materials inconsistent with the bright

yellow UV fluorescence of Edwards Formation chert (see Collins and Headrick 1990; Hofman et al.1991). A hand-held multiband UV-254/366NM (Model UVGL-58) light source with short and long wave capabilities was used for materials analyzed.

The lithic debitage was first size graded as specified by screen manufacturer Gilson Company, Inc. into 6.4 mm (1/4 inch), 12.5 mm (1/2 inch), 19.0 mm (3/4 inch), and 26.5 mm (1 inch) size groups as per TxDOT (2010). Each specimen was then sorted into platform-bearing and nonplatform-bearing groups. Nonplatform-bearing specimens were treated as shatter and weighed in bulk by provenience (specific to level and test unit). Platform-bearing specimens were examined individually and sorted into one of four classes: flat, multifaceted, crushed, and cortical. Other attributes documented include the presence/absence of heat alteration, cortex percentage (i.e., none, 1 to 25 percent, 26 to 50 percent, 51 to 75 percent, and 75 to 100 percent) and raw material type. Specimens were then weighed and findings entered into a database spreadsheet. Those that lacked a platform were grouped together on a single line, counted and weighed.

Lithic debitage lacks any macroscopic indications of use or modification. Pieces that exhibit any sign of use-wear or intentional modification are placed in the appropriate tool category. Some of the following categories were used in the experimental debitage analysis in Chapter 6.0 and in places where general discussion of sites debitage occurred that was not formally analyzed employing the TxDOT protocols.

#### ***Biface Thinning Flakes/Flakes with Complex Platforms***

Biface manufacture flakes were classified primarily based on the presence of complex striking platforms, multidirectional dorsal flake scars, parallel to slightly expanding flake margins, and slight to moderate longitudinal curvatures. This term is used in the experimental section.

#### ***Angular Debris***

Angular debris, or “shatter,” includes angular pieces of lithic raw material that break away from the core as flakes are struck. In contrast to flakes, angular debris does not generally retain any diagnostic characteristics of the flint knapping process (i.e., platforms, bulbs of percussion, concussion rings, and definable dorsal or ventral surfaces). In this analysis, those few pieces of angular debris that exhibit characteristics diagnostic of biface manufacture were included in the appropriate biface manufacturing category (i.e., early versus late-stage biface flakes).

#### ***Indeterminate Flakes***

This category includes flakes and flake fragments that lack diagnostic traits that would permit their placement into one of the other categories. Generally, these flakes are small fragments of flakes and/or thin pieces of angular debris that do not display clear evidence of a platform, concussion rings, or flake scar patterning on their dorsal surfaces. This category also includes a small number of potlid flakes and fractured heat spalls resulting from thermal alteration of raw materials.

#### ***Cores***

A core is a cobble, pebble, or other mass of lithic raw material that exhibits one or more platforms and flake scars resulting from the systematic removal of flakes by flint knappers (Parry and Kelly 1987). Technically, any chipped stone tool may properly be classified as a core as it is the object created through the removal of flakes from the exterior surface of the original mass of lithic material. In common terms, however, cores are generally considered to be those masses of material from which one or more flakes were removed. In other words, cores do not exhibit any intentional or use-related flake scarring along any of their edges, though scars resulting from platform preparation may be evident, and a core might be expediently used as a tool (e.g., extensive crushing damage along one or more thick edges of a core would

probably result in classification of the object as a chopper).

Various types of cores are recognized according to the degree of knapping and the flake removal strategy. Four basic types of cores are unifacial, bifacial, multidirectional, and blade core. The last named type often has a distinctive conical polyhedral shape, the result of the repeated, parallel removal of long, narrow flakes known as prismatic blades.

A unifacial core is one that exhibits flake scars removed from only one face. The flake removals may be in various directions and exhibit no pattern or structure to the removals. There are usually only one or two platforms.

A bifacial core exhibits flake removals from both faces and again these may be in multiple directions. The parent or objective rock is generally a cobble that exhibits two detectable faces. The flakes were driven from the lateral edges; thus, the platforms are along the edges.

The multidirectional core is generally a chunk of raw material that does not necessarily exhibit two obvious faces. Generally, there are a number of platforms from which flakes were removed. Most often, the flakes are removed in different directions.

Blade cores are chunks of raw material intentionally prepared to facilitate the removal of a specific kind of desired flake. These generally exhibit two or more parallel scars driven from the same platform in the same direction with the same overall shape.

#### **4.3.1.3 Ground Stone Tool Analyses**

This broad artifact class includes pieces of natural rock that have been modified by grinding either to intentionally shape an implement or as a by-product of use. Ground stone tools are recognized by the presence of intentional abrasions, grooves, and striations and/or smoothing. Significant rounding,

flattening, and/or pitting of utilized surfaces can also be identified. Categories of ground stone tools can include manos, metates (milling stones or grinding slabs), abraders/shaft smoothers, and edge-ground cobbles.

The edges and surfaces of each rock were macroscopically examined for signs of use as a tool. If battered, smoothed, unnaturally flattened, pitted, ground, striated, incised, or pecked areas were identified, then the artifact was assigned to a morphological and/or functional category based on general form and inferred function. Sets of observations were recorded for the tool classes recovered. The following subsection provides a definition of major tool class identified.

#### ***Manos and Metates***

Manos and metates are generally used together to grind friable materials (nuts, seeds, other vegetal matter, and sometimes pigments) into powder. A mano is a hand-held grinding stone, generally characterized by a round to ovate shape, usually of hard, dense siliceous rock such as quartzite, dolomite, or sandstone. One or more surfaces exhibit a smooth or polished, and/or possibly flattened area caused by grinding action against another hard surface (the metate). In some instances, the edges exhibit crushed or pitted areas indicating possible use as hammerstones as well. Sometimes one or both faces may be pitted, which results from the user trying to rough up the smooth surface to facilitate the grinding. Generally, these are water worn cobbles that exhibit no other alterations to the natural cobble.

A metate is often a large slab of a dense rock such as sandstone, limestone, or dolomite, which has served as the base on which the mano is used to grind materials. The grinding action most often wears the natural surface and creates a shallow concave face that is smoothed and/or polished. Extensive and continued use creates a deeper concave basin and in some instances, both faces served as foundations for grinding. Occasionally,

the edges of metates are artificially shaped, usually by direct percussion that removed flakes along the margins. Metric and nonmetric observations were recorded for manos and metates. Measurements of dimensions were recorded only when the dimension in question was completely represented and/or could be reasonably estimated.

#### 4.3.1.4 Battered Stone Tools

This artifact class includes pieces of natural rock that exhibit evidence of modification by pecking or hammering to intentionally shape an implement or as a by-product of use. Battered tools are recognized by areas crushed, peck marks or pits. Categories of battered tools include hammerstones and pitted slabs, etc.

#### 4.3.1.5 Mussel Shell Analysis

Recovered mussel shell was compared to TRCs extensive modern and prehistoric comparative collection that has been identified and individually labeled. Original identifications were performed by Dr. R. G. Howells. To confirm the initial identification, specimens were compared to modern pictures and finalized by our in-house specialist Barrett Clark. Habitat data were obtained from literature sources (i.e., Howells et al. 1996).

#### 4.3.2 Flotation Methods

Bulk sediment samples that totaled 9.9 liters and included sediment from three feature proveniences (Features 2, 3, and 4 at 41LM51) were mechanically floated. Flotation was conducted at the TRC Austin facilities in south Austin using the Dousman flotation system (Figure 4-4). The dry sediment was first measured for volume and then poured into the churning water. The light and heavy fractions were collected separately and dried.

In the Austin laboratory, each heavy fraction was spread across a clean white paper and the remains were sorted into general artifact classes such as flakes, shells, burned rock fragments, charcoal,



Figure 4-4. Dousman flotation system used to float sediment samples.

bone, etc. The sorting was facilitated with the aid of magnification. The frequencies and weights of the various classes were recorded on forms and results incorporated into appropriate the feature discussions. The light fractions were scanned in the laboratory under magnification searching for charred seeds and other possible cultural materials.

Charcoal or other carbonized materials were not observed in light fractions. The small (1.3 g) light fraction (#104-4-c) obtained from Feature 4 at 41LM51 was sent to archeobotanist Dr. Leslie Bush for her review, and assessment for further detailed analyses.

#### 4.3.3 Technical Analyses

Five outsourced technical analyses: radiocarbon dating, macrobotanical identifications, starch grain, use-wear, and phytolith analysis, were performed on a selected suite of artifacts. These five techniques were employed to gain greater insights and understanding of the prehistory at this project location, such as: ages of the deposits and associated cultural materials, indications as to foods potentially employed during these occupations, and

past vegetative characteristics for specific points in time.

Following the fieldwork, and in conjunction with the interim testing report (Quigg and Frederick 2005), 17 macrobotanical samples from the three sites were selected and sent to Dr. J. Phil Dering of Shumla Archeobotanical Services in Comstock, Texas, for identification. Dr. Dering's results are presented in Appendix H. Also, 6 sediment samples from 41LM51 were submitted to Dr. Steven Bozarth in Lawrence Kansas for assessment of phytolith preservation in the form of a presence/absence analysis. His results (positive with good preservation in 5 of the 6 samples) are presented in Appendix E and stimulated further phytolith analysis during subsequent analysis and reporting phases. Radiocarbon dating of 12 TxDOT approved samples was also conducted for the interim report (see details below). The combined results were used to aid in the initial research direction in formulation of the data recovery plan presented in the interim testing report (Quigg and Frederick 2005).

The technical reports are presented in individual appendices and provide details on the methods, analytical results, and interpretations. The results are also incorporated into the body of this report.

#### **4.3.3.1 Radiocarbon Dating Analysis**

Charcoal, the preferred material for radiocarbon dating, was recovered in very limited quantities. Consequently, other substances with the potential for organic content were selected to provide alternate means of potentially obtaining absolute dates. An absolute date can be obtained from organic materials trapped in sediments, bones, shells, and sandstone burned rocks, although the obtained date may not be as precise as what one might obtain from charred seeds or wood. Direct dating of bones, sandstone burned rocks, and *Rabdotus* snail shells have been accomplished

previously with mixed results. Consequently, one must view dates derived from noncharcoal as a general 'ballpark' date, rather than a narrowly definable point in time. Following the 2004 fieldwork, TRC archeologists selected 12 samples (8 *Rabdotus* samples, 3 charcoal, and 1 animal bone) for direct radiocarbon (<sup>14</sup>C) dating of the three sites. A letter and list of samples was sent to James Abbott of TxDOT requesting approval of the 12 samples. After TxDOT approved the list of samples, those 12 samples were prepared and laboratory forms completed by TRC staff and submitted to TxDOT. TxDOT then submitted the 12 samples to the CAIS at The University of Georgia in Athens, Georgia.

The CAIS laboratory operates a 500 kV compact AMS unit for precise analyses of carbon isotopes, <sup>12</sup>C, <sup>13</sup>C, and <sup>14</sup>C, at extremely low (parts per quadrillion) concentration levels. The National Electrostatics Corporation Model 1.5SDH-1 Pelletron Accelerator Mass Spectrometer (AMS) provides the means to directly count the number of <sup>14</sup>C atoms in a sample, so that even extremely small (microgram size) samples can be used for quantitative determinations of very low-level isotopic concentrations. Precision of <sup>14</sup>C measurements is better than 0.3 percent. The sensitivity of the instrument is comparable to that of much larger units, with theoretical detection limits as low as 4 attomoles (4 x 10<sup>-18</sup> moles) of <sup>14</sup>C. Geological graphite <sup>14</sup>C/<sup>12</sup>C ratios average 7.5 x 10<sup>-16</sup>.

The charcoal samples were pretreated by CAIS with acid, alkali and acid, the shells were treated with mild acid, and the collagen was extracted from the bone sample prior to processing for AMS dating. The derived dates are reported as radiocarbon years before present (B.P.), with "present" being A.D. 1950 using the international convention Libby <sup>14</sup>C half-life of 5,568 ± 30 years. Each sample was measured for <sup>13</sup>C verses <sup>12</sup>C



ratios ( $^{13}\text{C}/^{12}\text{C}$ ) expressed as the delta 13 carbon ( $\delta^{13}\text{C}$ ) and calculated relative to the internationally standard Cretaceous belemnite formation at Peedee, South Carolina (PDB or VPDB). The CAIS individual laboratory reports concerning each sample are presented in Appendix B. Individual sample results are also presented and discussed throughout the body of this report.

In March 2013, during the initial stages of data analyses for the final reporting phase, another 8 samples (5 sandstone burned rocks and 3 wood charcoal samples) were requested for dating to support the previous 12 radiocarbon dates obtained for the 3 sites. Again, the request and justification for dating these 8 samples was sent to James Abbott of TxDOT. These 8 samples were approved for dating, and a TRC archeologist prepared the samples, completed the laboratory forms and submitted the samples to TxDOT. At that time, Beta Analytic Inc. (Beta), in Miami, Florida, was the laboratory conducting the dating process for TxDOT.

With instructions from TRC archeologists, Beta tried to extract only the darkened outer margins of the burned rocks for use in the dating process. Beta's extraction procedure included the use of a chisel and hammer to remove the darkened rind from the surfaces of the rock, to extract only the outer stained areas and most recent organic residues. As each sample differed due to the thickness of the rind and discoloration, it was unclear how much material would actually be needed.

Beta dates are reported as radiocarbon years B.P., as standard and with same half-life and measurements for  $\delta^{13}\text{C}$  as CAIS. Beta's individual laboratory reports, with specific details concerning each sample, are presented in Appendix B. Individual sample results are also presented and discussed throughout the body of this report.

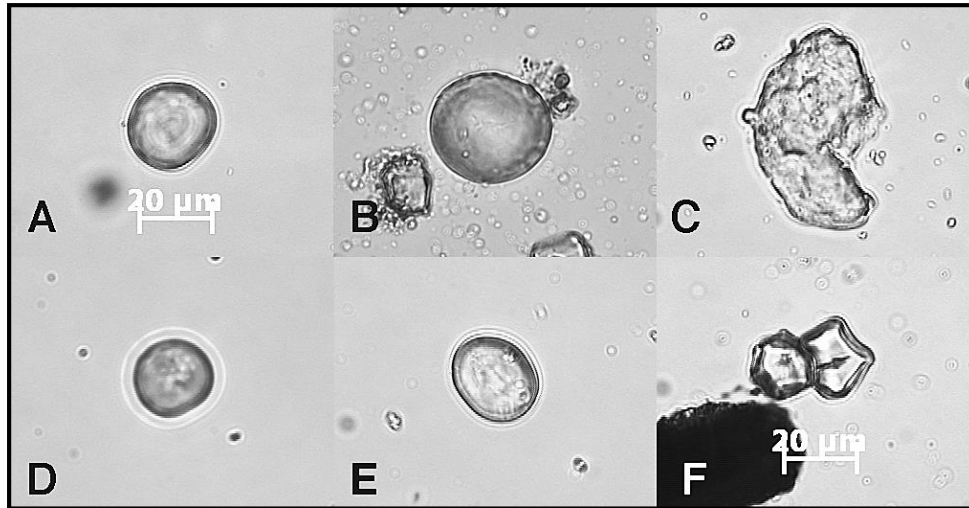
### 4.3.3.2 Macrobotanical Analysis

As indicated above, the initial charcoal identifications were performed following the fieldwork by Dr. Dering in 2005. As reported in the interim report (Quigg and Frederick 2005), his identifications of the 17 submitted samples (4 from 41LM49, 5 from 41LM50, and 8 from 41LM51) documented only the presence of wood charcoal and no potential food parts (Appendix H). Given that the largest and most likely identifiable samples were originally submitted, and no charred remains were detected in the scans of either heavy or light fractions from the flotation of feature sediments, no further samples were submitted during analysis in 2013.

### 4.3.3.3 Starch Grain Analysis

Starch grain analysis has become more widely used in Texas archeology (see Perry and Quigg 2011a; Quigg et al. 2010, 2011b, 2013a, 2013b). A brief introduction is provided as background to this discipline for those who might not be familiar with this technique.

Starch grains are microscopic granules that serve as the principal food storage mechanism of plants (Figure 4-5). The starches that archeologists study are storage starches rather than transient starches. It is this category of starch that is distinctive and diagnostic in morphology (Reichert 1913). These grains are found in storage portions of most plants such as roots and tubers (e.g., crow poison, rain lilies, false garlic, wine cup, and spring beauty), and in the seeds of legumes and grasses, where they are often produced in abundant numbers (Perry personal communication 2008). Just as different plants produce characteristically shaped leaves, flowers, and seeds, different genera and species make starch grains that are distinctive to, and diagnostic for, each taxon. The anatomical features that distinguish the starch of one species of plant from another have been noted by botanists (e.g.,



**Figure 4-5. Examples of starch grains of wildrye grass recovered from burned rocks at an archeological site in Texas (photograph by L. Perry).**

Denniston 1904; MacMasters 1964; Reichert 1913), and their methods have been expanded by archeobotanists, who are now able to distinguish wild from domesticated species in some plant families (Iriarté et al. 2004; Pearsall et al. 2004; Perry 2001, 2002, 2004; Perry et al. 2007; Piperno et al. 2000). Successful identification of starch granules relies upon viewing each grain in three dimensions under high-powered microscopes for accurate assessment of morphological features.

Distinctive features of starch grains are genetically controlled and can be used to identify plant taxa when carefully observed. Minimally, 300 species and varieties of important economic plants from around the world have been described and are potentially preservable in archeological contexts (Piperno and Holst 1998; Piperno et al. 2000). Researchers around the world (particularly in the neotropics and in Australia) have used these techniques with excellent results (Perry personal communication 2007). Starch grain remains have significantly increased the knowledge of plant domestication and crop-plant dispersal in various regions (Perry et al. 2006:76-77).

Starch grains have been extracted from soil samples, ceramics, burned rocks, and chipped and

ground stone tools to address questions of resource procurement and preparation of foods. Intact starch grains have been extracted from formal and informal chipped stone tools, both washed and unwashed (Perry personal communication 2007). Heat alone does not destroy starches, as they are found in ceramic cooking vessels and in burned rocks (Quigg et al. 2010, 2011b, 2013a, 2013b; Perry and Quigg 2011a, 2011b). Researchers have employed starch grain analyses to investigate diet, plant processing, plant domestication and cultivation, tool use, and uses of ceramic vessels.

Another significant aspect of starch grain analysis is that starches have been recovered from ground stone and burned rock artifacts, which indicate these types of plants, were processed both by mechanical means and through cooking strategies. When starchy plant tissues are processed, via mechanical procedures or cooking, damage occurs to the starch grains. Different types of damage can be diagnostic, and therefore can be used as signatures to reflect the processes that led to those damaged starches in the archeobotanical record (Babot 2003; Henry et al. 2009; Perry and Quigg 2011b; Williams 1982). To determine which types of processes (such as grinding, freeze-drying, or boiling) produce damaged starch grains,

experiments have been undertaken (see Perry and Quigg 2011b for an example). Basic processing procedures resulted in distinct patterning of damage to the starches, although specific times and temperatures did not create noticeably different morphological changes. Boiling starches from wildrye results in gelatinization of the grains, a process that enlarges the grains along a horizontal plane and creates undulations in their surface. Starches ground in a mortar and pestles develop cracks and some surface damage (often revealing lamellae, or growth layers, underneath the surface) and sometimes break into pieces. Seeds that were dry-roasted produced starches that were enlarged, distorted, and bumpy, with small particles of indeterminate material clinging to the surfaces of the grains. This ‘dirty’ look is in direct contrast to the ‘clean’ and curved starches resulting from boiling. No distinction was found between parching and roasting with indirect moisture (Perry and Quigg 2011b).

A total of 60 artifacts from these three sites were analyzed for starch grains in anticipation that starch from various plant resources would be present and identified. From 41LM50 and 41LM51, 18 chipped stone tools, 3 ground stone tools, and 5 sediment samples were selected and analyzed. The sediment samples from 41LM51 included three from features (Features 2, 3, and 4) as well as two non-feature contexts for comparisons and control. A suite of 34 burned rocks from individual features at three sites, specifically collected for starch analysis from identified cultural features, were submitted for starch analysis. Three types of burned rock features (*in situ* heating/cooking, secondary dumps of by-products, and a large burned rock mound/midden) were targeted, and included burned rocks from the mound at 41LM49, two small discard features at 41LM50, and discard/dump features at 41LM51. The selection process included sampling the features (identified as representing different function and time periods), in anticipation of possible identification of food resources utilized

within differing features and cultural periods. It is notable that most burned rocks recovered were limestone, with a small percentage sandstone pieces. Although both rock types were sent for analysis, it was a concern that limestone would not retain starch grains as well as more porous sandstone. Starch grains were recovered from 50 percent of the sandstone and 30 percent of the limestone pieces. Dr. Perry’s methods, results, and interpretations are presented in Appendix D. Individual sample results are also presented and discussed in the body of this report.

#### 4.3.3.4 Use-Wear Analysis

Formal chipped stone tools are generally categorized by overall form, with an assumed function, such as pointed projectiles for tipping arrows or dart shafts, and scrapers for scraping hides, etc. This generalized classification strategy was used throughout this report. However, to gain greater insights into the actual tool function of certain tool classes, a suite of 35 chipped stone tools from 41LM50 and 41LM51 were selected and sent for high-powered microscopic use-wear analysis. Most tools selected were originally washed, although a few remained unwashed. Each artifact was archivally labeled in ink with the site and provenience number in a small area and then the label was coated with B-72 to preserve it. These artifacts were submitted to Dr. Bruce Hardy at Kenyon College in Gamber, Ohio.

The 35 tools of the analyzed assemblage include 21 chipped stone items from 41LM50: 20 from the Late Prehistoric component, and 1 large biface (#66-10) from the lower possible component. Tools submitted included 3 formal biface fragments, a thin gouge, and a distal fragment of an end scraper. Edge-modified flakes with a wide range of modifications were intensively sampled ( $n = 16$ ) as they presumably served in multiple ways (i.e., cutting, scraping, engraving, whittling, etc.) on multiple materials (i.e., skins, wood, bone). It was anticipated that their results would reveal the

greatest diversity in tasks performed at this site. From 41LM51, 14 artifacts (12 from the presumed Late Archaic component, 1 each from the Toyah and Gower components) were selected and submitted. The submitted sample included formal tools (3 biface fragments and 2 scrapers), but was again dominated ( $n=9$ ) by informal edge-modified tools. Hardy's analytical methods, individual observations, and results are presented in Appendix C. Use-wear results are also incorporated into appropriate sections within the body of this report.

#### **4.3.3.5 Phytolith Analysis**

Phytoliths are inorganic siliceous residues that form in plant cells and frequently mirror parent cell shape. When the plant dies, these tiny bodies become a mineral particle in the soil. Phytoliths often survive for thousands of years and provide evidence of past vegetation landscapes and general environmental conditions. The distinctiveness of different types of phytolith bodies varies according to cellulosic structure. Phytoliths exhibit diversity and are distinct among grass species. The presence of certain short cell grass phytoliths (e.g., panicoids, pooids, and chloridoid) in the paleoenvironment record provides a record of the general grass community. Therefore, phytoliths are important for reconstructing a general profile of the grassland flora. Unfortunately, diagnostic phytoliths are rarely formed in edible fruits or nuts. However, common domesticated plants such as the common beans (*Phaseolus vulgaris*), specific species in the sunflower family (Asteraceae), rinds of selected varieties of squash (*Cucurbita* species), and maize (*Zea mays*) all yield recognizable phytoliths (Bozarth and Woodburn 2010).

As mentioned above, following eligibility assessment, a phytolith presence/absence assessment on 6 sediment samples from 41LM51 was conducted by Dr. Steven Bozarth from the University of Kansas Palynology Laboratory. His

positive results, presented in the interim assessment report (Appendix F), stimulated the subsequent phytolith analysis. Nine sediment samples (3 from 41LM50 and 7 from 41LM51) were submitted to Dr. Byron Sudbury of J. S. Enterprises, Inc. in Ponca City, Oklahoma, for identification, full analyses, and reporting. The samples consisted of sediment collected from five burned rock features: Features 1 and 2 at 41LM50; and Features 2, 3, and 4 at 41LM51. These samples were submitted in anticipation of potential identification of food resources associated with those features. The remaining 5 samples from the two sites targeted natural environmental conditions at specific points in time, and were also used as a control to help evaluate the results from the cultural features. Dr. Sudbury's analytical methods, individual observations, results, and interpretations are presented in Appendix F.

#### **4.4 CURATION**

Artifacts collected from this 2004 assessment project were temporarily curated at the offices of TRC in Austin. All collected and curated artifacts, field records, and digital photographs from this assessment are permanently curated. Individual artifacts or artifact lots, (including stone tools, lithic debitage, mussel shells, animal bones, and burned rocks) are bagged in clear, zip-locking four millimeter thick archival polyethylene bags according to provenience. Each polyethylene bag contains an archival-quality, acid-free curation tag that lists the site number, provenience data, date of excavation, excavator(s) name, artifact type, and quantity in pencil. Digital photographs were submitted on CD along with a printed contact sheet. All original field records are on acid-free paper and were placed in acid-free file folders for curation. The materials, artifacts, records, and photographs will be curated at TARL in Austin.

*This page intentionally left blank.*

## **5.0 RESEARCH DESIGN FOR SITES 41LM50 AND 41LM51**

Robert A. Ricklis, Paul M. Matchen, J. Michael Quigg, and Jason Barrett

### **5.1 INTRODUCTION**

An initial data recovery plan for sites 41LM50 and 41LM51, accompanied by broad research issues to be addressed, was submitted with the interim report (Quigg and Frederick 2005). Following that a formalized final draft research design was submitted by TRC to the Archeology Studies Program at TxDOT in 2007 (Ricklis et al. 2007). The draft provided an outline and the sequence of analysis to address Shafer's 2006 Prairie Caddo model. TxDOT archeologists provided specific comments that were added and TxDOT archeologist Jason Barrett wrote major sections concerning the procedures for the experimental analysis that were incorporated into this final version. This chapter presents the final research design as originally presented, and as such, the future tense is used to refer to studies that are now complete. This research design is presented to provide the reader with context to better understand the analyses and the conclusions of this investigation.

### **5.2 STRATIGRAPHY AND CHRONOLOGY**

In order to provide a meaningful temporal and cultural context for the artifacts and features documented at these sites, TRC proposes to review and present the cultural-stratigraphic data for each site. Where possible, identified cultural strata and features will be placed within a temporal framework on the basis of radiocarbon dates. Where radiocarbon dates are not available, the ages and basic cultural periods to which strata and features pertain will be estimated on the basis of their relative vertical positions within site stratigraphic profiles.

### **5.3 FEATURE FUNCTIONS**

Functions of features are interpreted where possible, based on constituent materials (e.g., burned rocks, lithic debitage, and charcoal), feature morphology, and analyses of residues on burned rocks. The residue analyses will involve phytoliths and starch grains to provide additional information relevant to this question.

### **5.4 SUBSISTENCE PATTERNS**

For each of the cultural periods identified by the stratigraphic studies, patterns of subsistence economy will be inferred, to the extent possible, based upon ecofactual data (e.g., macrobotanicals, faunal remains, and shells) as well as results from residue analyses. Phytolith and starch grain data are expected to contribute insights into the range and variety of plant resources that were utilized.

### **5.5 STONE TOOL FUNCTIONS**

Use-wear analyses are proposed for selected formal and informal/expedient stone tools, with the goal of determining the kinds of tasks carried out during occupations of the sites. It is expected that the results of this effort will aid in making correlations between tool use and the range of utilized resources revealed by other studies, such as the starch grain and phytolith analyses.

### **5.6 THE QUESTION OF THE SOCIOCULTURAL IDENTITY OF THE LATE PREHISTORIC OCCUPANTS OF 41LM50**

Two of the three sites tested by TRC archeologists, 41LM50 and 41LM51, yielded evidence of occupations during the Late Prehistoric period. The third tested site, 41LM49, yielded only a profile of one burned rock mound minimally within the existing right-of-way (ROW) and no associated time-diagnostic artifacts, it has no potential to elucidate significant research issues due to a lack of definable cultural chronology. Thus, data recovered

from excavations at 41LM49 are not contributing elements to the research design formulated here. Since 41LM51 has only a late-phase, Late Prehistoric component that is most likely Toyah or its chronological equivalent, it also is not relevant in addressing the question of the cultural identity of resident groups during the early part of the Late Prehistoric period, the chronological period of interest here (see below). Thus, data from 41LM51 will receive only ancillary analysis and documentation as a largely non-contributing element within the overall research design of this project.

### 5.6.1 Late Prehistoric Cultural Identity and Shafer's Prairie Caddo Model

Harry J. Shafer (2006) proposed that the prairies of east-central Texas, which include the Lampasas County area, were inhabited during the early part of the Late Prehistoric period by Caddo people who were related to the occupants of the George C. Davis site (41CE19), a large Caddo mound site to the east in the woodland landscape of Cherokee County, Texas (Figure 5-1). In support of this suggestion, Shafer points to the presence of artifacts from sites on the prairies that are technostylistically equivalent to comparable materials from the Davis site. These include: a) early Caddo pottery types, b) Alba-Bonham arrow points, c) Gahagan bifaces, d) bone needles, and e) deer metapodial bone beamers (defleshing tools).

Taking note of the fact that Late Prehistoric assemblages from the prairie margins of east-central Texas fit into neither the Austin phase or the Toyah phase, Shafer stated that,

The working hypothesis...is that the material culture in the prairie area is distinctive and can be distinguished from that of earlier and later constructs and from contemporaneous assemblages in adjacent geographic regions based on the technological

styles and is more closely related to that of the George C. Davis site and other Caddoan assemblages than to either the Austin or Toyah constructs as currently defined (Shafer 2006:1).

Alba (and Alba-like) arrow points, among the key traits of the Prairie Caddo in Shafer's model, were recovered from upper levels at 41LM50, along with samples of lithic debitage (mainly chert). This raises the possibility that this site may have been occupied by Caddo people who had links to the east Texas Caddo homeland. On the other hand, no pottery was found in association with the arrow points, which implies that either this site component is: (a) too early in the cultural sequence to produce pottery; (b) too limited in terms of the range of on-site activities for ceramics to have been a part of the functional assemblage deposited at the site; or that (c) TRC's testing work was too limited in scope to have recovered a fully representative sample of material remains. The latter indicates that more extensive excavations might have yielded a limited amount of pottery, as at the J. B. White site (41MM341), where extensive excavations resulted in the recovery of only four potsherds (Gadus et al. 2006:124). It is reasonable to suggest that ceramics may not have been documented at 41MM341 had work there been limited to the same excavated volume (6.5 m<sup>3</sup>) as TRC's excavations at 41LM50. Therefore, based on the present recovered assemblages that lack pottery from either Late Prehistoric component we assume that pottery was not a significant part of the artifact assemblage at either 41LM50 or 41LM51. The absence (or potential underrepresentation) of pottery at sites 41LM50 and 41LM51 can be hypothetically interpreted in a number of ways. Perhaps most simply, is that the sites pertain to the formative or early period of the Late Prehistoric (ca. A.D. 700 to 900); that is, essentially contemporaneous with the pre-ceramic Austin phase as defined for central Texas (Jelks 1962; Prewitt 1981, 1985). While this

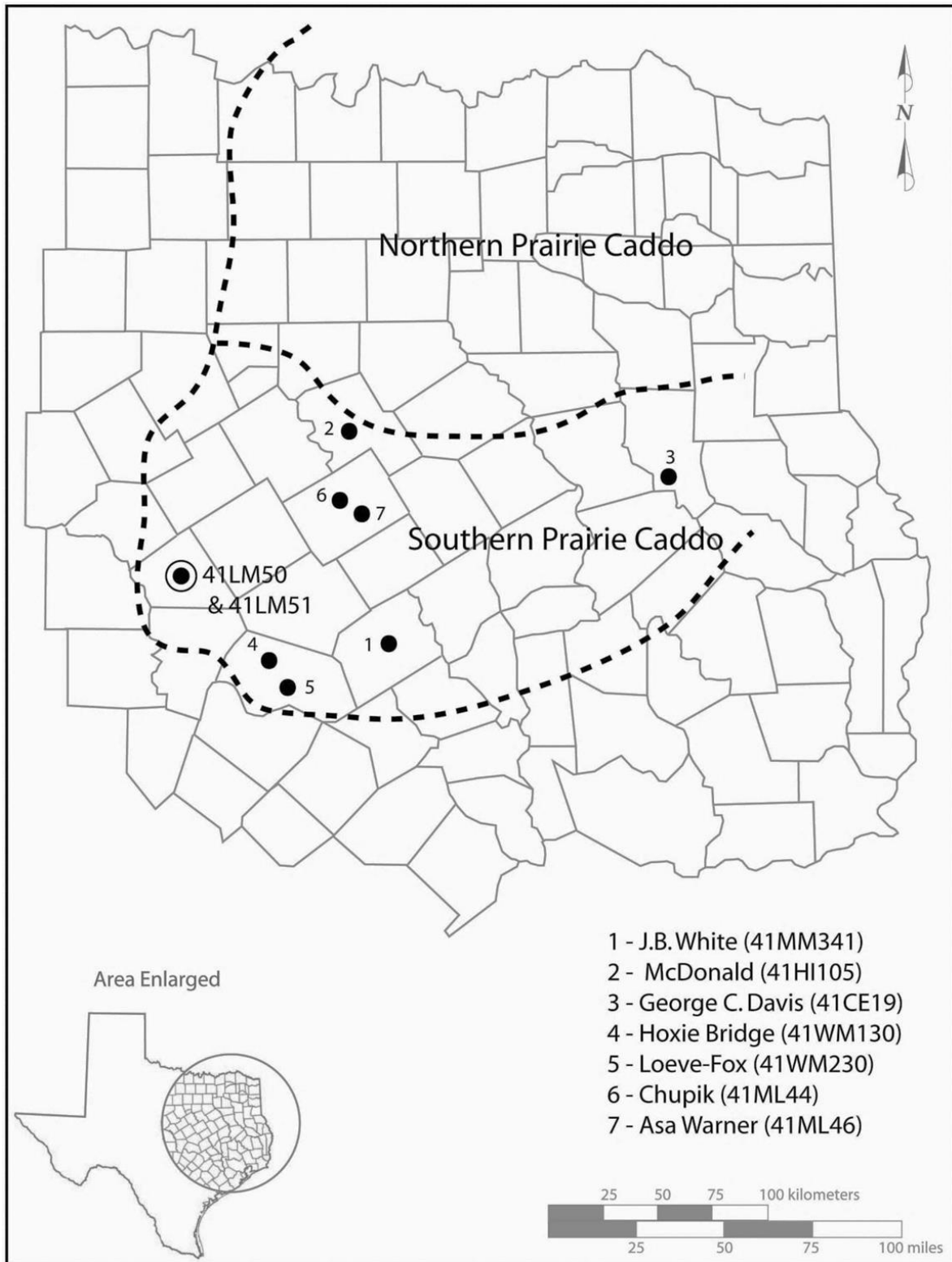


Figure 5-1. Map illustrating Shafer's (2006) proposed Prairie Caddo habitats.



may be the case, sites 41LM50 and 41LM51 cannot be directly linked to that techno-cultural sphere since no Scallorn arrow points (the key Austin phase diagnostic artifact) were recovered. The Bonham and Alba types, represented at 41LM50 are generally acknowledged as contemporary with the Austin phase (see Turner and Hester 1999:56-60), which lends support to the premise that 41LM50 was occupied relatively early in the Late Prehistoric cultural sequence. Diagnostic artifacts of central Texas' later Late Prehistoric cultural sequence, such as Perdiz arrow points and bone-tempered plainware pottery (both generally dating to after ca. A.D. 1300), are absent from the upper component assemblage at 41LM50.

A second implication of the absence (or marked scarcity) of pottery at sites 41LM50 and 41LM51, is that the site occupants were not ethnically Caddoan. This is in significant contrast to Shafer's proposed Prairie Caddo model, which postulates the presence of early Caddo manifestations in the study region, contemporaneous with occupation of the Lampasas County sites of present concern. The model states that techno-cultural traits associated with Prairie Caddo groups will include early Caddoan pottery, deer metapodial beamers, bone needles, Bonham-Alba arrow points, and Gahagan bifaces (Shafer 2006). From this perspective, the absence of bone tools – in particular needles and beamers – from artifact assemblages at the Lampasas County sites may also be relevant. However, the impact of sampling strategy and the possibility of poor organic preservation within specific deposits must also be considered when evaluating the representation of bone artifacts within site assemblages.

With respect to the available data, only the arrow points from 41LM50 hint at a potential connection with ethnically Caddoan groups. Shafer has also suggested that Prairie Caddo were manufacturing Gahagan bifaces (Figure 5-2) from high-quality

central Texas cherts, ultimately for use in the Caddo heartland (2006:33).

From this perspective, Caddo people from the wooded heartland of east Texas may have made repeated forays onto the prairies to obtain desired resources that were not available locally, or were available only in limited amounts. We propose that if the occupants at site 41LM50 were Caddo or Prairie Caddo, we should expect to see evidence of such reflected in the site's artifact assemblage, especially within the well-preserved lithics. In contrast, the significance of the absence of ceramics is more ambiguous. An assemblage devoid of ceramics may be expected if the site represents a limited-function, resource procurement site, regardless of its cultural affiliation. In such a scenario the full complement of material culture observed in the context of a residential base camp should not necessarily be expected.

### 5.6.2 Research Objectives

The objective for the proposed research is to evaluate the fit of separate models of cultural affiliation against data from 41LM50 through experimental study, analysis of archeological collections, and literature review. The various models offered for evaluation propose that site 41LM50 represents either: [1] a currently undefined hunter-gatherer cultural pattern carried by people



**Figure 5-2. Gahagan biface illustration from Turner and Hester (1993:255).**

living on the prairie who could have been engaged in trade with Caddoan peoples; [2] a temporary/seasonal resource procurement camp utilized by Caddoan people from the east Texas Caddo heartland; or [3] Caddo people who inhabited the prairie environment.

To test for the presence and activities of Prairie Caddo people, we propose to produce and analyze an experimental assemblage of debitage generated through the manufacture of Gahagan bifaces, Friday bifaces, and large beveled knives. If production of Gahagan bifaces occurred at 41ML50, that could indicate the Caddo cultural affiliation of the site's occupants as either a resident population of Prairie Caddo, or as people from the Caddo heartland within the context of a temporary procurement camp. Alternatively, it could indicate the production of Gahagan bifaces by local hunter-gatherers for exchange with Caddo peoples to the east, a scenario in which a connection with Caddo peoples is represented, but in which the physical presence of Caddo peoples on the prairie, as suggested by Shafer, was not necessarily the case. In either case, certain aspects of Caddo influences/connections that underlie Shafer's Prairie Caddo model may be archeologically identified.

A lithic debitage assemblage derived from Gahagan manufacture can be expected to exhibit large biface thinning flakes, but such flakes are not diagnostic of Gahagan production in and of themselves. The production of other Late Prehistoric bifacial forms, such as Friday bifaces and large beveled (Harahey) knives, can also be expected to generate large biface thinning flakes, and neither form represents a known Caddo cultural marker. Thus, the three tool forms being replicated within the experimental assemblage will represent more or less contemporary tool types that may each produce similar debitage attributes. We thus propose to conduct an experimental study designed to test whether this is actually the case or, alternatively,

that the production of Gahagan bifaces results in uniquely diagnostic flake attributes within an associated collection of debitage.

Should the experimental study indicate that Gahagan biface production is identifiable on the basis of the resultant debitage, we propose to then follow it up with an analysis of lithic debitage from site 41LM50 to ascertain whether the site's occupants were producing Gahagan bifaces. Together with the Bonham and Alba points recovered in excavations at 41LM50, the presence of Gahagan biface manufacture would support the identification of the site's inhabitants as Caddo, or at least suggest the above-mentioned alternative that local people were involved in a production and exchange network that included Caddoan peoples (Figure 5-3). However, if Gahagan manufacture cannot be objectively identified by diagnostic debitage within the experimental assemblage, then the assertion that the occupants of 41LM50 were culturally affiliated with the Caddo, or were an unaffiliated foraging people producing large bifaces for export to the Caddo, cannot be objectively evaluated.

### **5.6.3 Procedures for the Experimental Study**

Determining whether diagnostic components of Gahagan production exist within debitage assemblages is of primary importance within the context of the proposed research. Specifically, debitage produced in the manufacture of Gahagan bifaces must be distinguishable from that resulting from the production of other Late Prehistoric large, thin bifaces known to have been produced in the region (i.e., Friday bifaces and beveled bifacial [Harahey] knives).

Toward this end, each large bifacial tool form (Gahagan, Friday, beveled knife) known to have been produced during the Late Prehistoric within the general region will be replicated and the resulting debitage analyzed. Total reliance on the

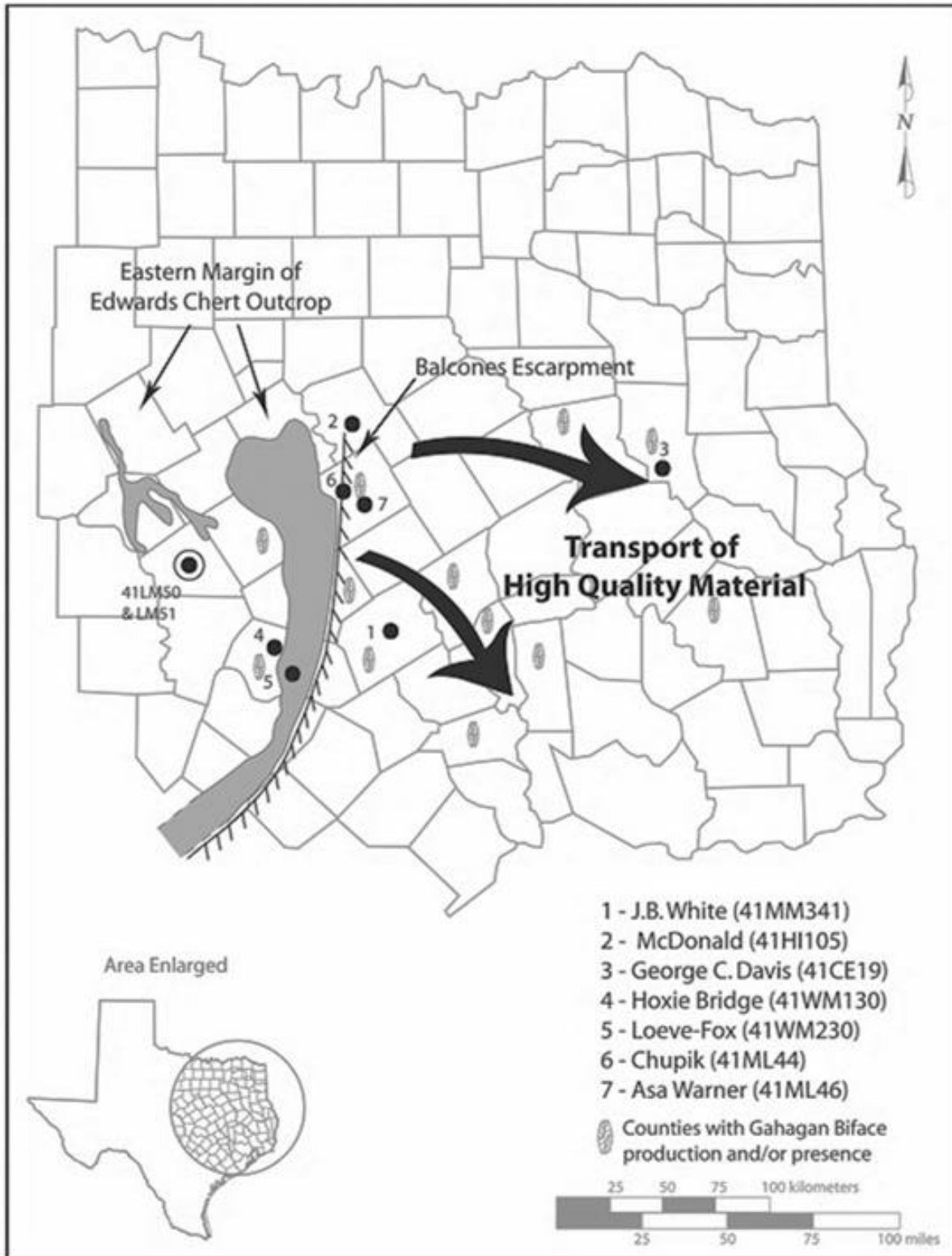


Figure 5-3. Map showing a possible model of high-quality material distribution for Gahagan biface manufacture throughout east-central Texas among groups in the Late Prehistoric period (chert distribution modified from Frederick and Ringstaff 1994).

debitage assemblage is necessary in this instance, as no diagnostic tool forms other than arrow points were recovered during evaluation excavations at 41LM50. The following procedures will be observed in carrying out the proposed experimental study:

- Each of the tools will be replicated using only technologies available aboriginally (materials and techniques reasonably thought to have been available to the region's prehistoric flintknappers). In keeping with discussions between TRC and TxDOT archeology staff, the replications are to be produced by Mr. Chris Ringstaff, a staff archeologist for TxDOT.
- For each tool produced, waste flakes created during the manufacturing process will be retained for study from each stage of tool production as defined in TxDOT's 2010 protocol for chipped stone analysis, Version 2.1 (Texas Department of Transportation 2010).
- Debitage by-product analysis will be completed in accordance with TxDOT's 2010 protocol for chipped stone analysis, Version 2.1.
- Analytical data will be recorded in such a way that it allows for the study ofdebitage from distinct production stages, as well as from various stage combinations.
- To control for the influence of raw material types on assemblage composition, two of each tool form will be replicated: one using a tabular raw material package, the other using a nodular raw material package.
- The effects of raw material variability on assemblage composition will also be reduced by ensuring that the initial lithic packages used in producing each tool form are of comparable size and material quality, and display comparable cortex characteristics.
- For these purposes, it is assumed that thedebitage sample from 41LM50 is representative of on-site knapping activities and has not been significantly affected by either

C- or N-transforms. A C-transform is a force or process that alters the original state of an archeological object or context (artifact, ecofact, or feature) and that has a cultural origin, whereas N-transform is a similar force/process that has a natural origin.

Ifdebitage produced in the manufacture of Gahagan bifaces can be shown to differ from both Friday bifaces and beveled knives following the completion of analysis on the experimentaldebitage assemblage, either through statistically significant differences in compositional elements or through the presence of diagnostic attributes, then the fit of the proposed models can presumably be evaluated. If not, the fit of the proposed models cannot be tested. The need for additional research and the composition of the final report will vary, based on which of these two outcomes is realized by the experimental study.

#### **5.6.4 Research Based on the Results of the Experimental Study**

##### **5.6.4.1 Scenario One: Gahagan Manufacture Can Be Experimentally Detected**

**(1a):** Gahagan biface manufacturingdebitage can be experimentally detected, and there is evidence for its presence at 41LM50.

If Gahagan manufacture is experimentally detectable, and site 41LM50 does appear to represent Gahagan manufacture based on a comparison between the site'sdebitage and the experimentally deriveddebitage assemblage, thendebitage from a maximum of two additional sites (known to represent Gahagan production) will be compared to the experimental sample to validate both its broad applicability as a nominal measure of Gahagan manufacture, and also to quantify the differences in assemblage characteristics. Analysis of these additionaldebitage collections will be independent of any analyses already performed on those collections, and will be performed in

accordance with TxDOT's protocol for chipped stone analysis (TxDOT 2010).

Also, if site 41LM50 does reflect Gahagan manufacture through comparison with the experimentally derived debitage assemblage, then lithic artifact analysis will include a characterization of raw material variability at 41LM50. Raw material variability (including an assessment of quality, probable proximity of nearest raw material source, and relative representation) will be characterized for the entire chipped stone assemblage discussed in analytical units at 41LM50 to determine whether raw material quality varies between Gahagan bifaces and other types of chipped stone tools. This characterization will not include chemical characterization procedures such as INAA, but will instead be based on the observation of macroscopic attributes of the lithic material. This characterization will focus on natural raw material variability and specifically address whether observed variability is the result of either chemical or mechanical alteration (e.g., thermal alteration, patina formation) rather than mineral composition.

The primary comparison in raw material analysis will be between the debitage determined likely to be the product of Gahagan biface manufacture in contrast to all other debitage represented in the artifact assemblage. To clarify, the material character and quality of known Late Prehistoric Gahagan manufacturing waste will be compared with debitage resulting from the production of other tool forms within the Late Prehistoric assemblage (e.g., Alba/Bonham-Alba arrow point production waste – as inferred by comparison with Alba/Bonham-Alba points recovered in excavations).

Raw material types will be examined to determine if higher-quality cherts are disproportionately represented in the Gahagan-related flake category as opposed to other flake-type groupings. Gahagan bifaces made for use in east Texas can be expected

to have been made of high-grade (fine-grained) as opposed to low-grade (coarse-grained) cherts. As a result, we would expect a positive correlation between high-quality material and Gahagan bifacial thinning flakes. Conversely, we expect flaking debris from the production of other tool types to be comprised of lower-grade material given that they presumably reflect production of more generalized, potentially informal tool types intended for on-site tasks.

Raw material quality will be determined by establishing a range of criteria within which the 41LM50 lithic assemblages will be classified. These criteria are likely to include raw material type (mineralogy), grain size (defined as fine to coarse), and presence of thermal alteration (defined by luster and color). Material homogeneity will be assessed within the lithic assemblage to estimate the character of the resource outcrop or the likelihood that multiple outcrops were exploited. TRC will also evaluate whether the debitage and the tools discarded at 41LM50 represent contrastive resources, suggesting that tools produced with some nodules were exported from the site and, potentially, that some of the tools represented were made from non-local resources.

For the sake of clarity, we reiterate that the comparison of debitage from additional sites (other than the 41LM50 assemblage), as well as the characterization of raw material variability and assessment of the relationship between tool form and function within that assemblage, will only be undertaken if Gahagan manufacture can be experimentally distinguished from other forms of large biface manufacture, and if it is determined to be represented at 41LM50.

**(1b):** Gahagan biface manufacture can be experimentally detected, but evidence for that activity is not detected at 41LM50.

In this scenario, debitage from the two additional sites (known to represent Gahagan production, as

discussed above) will not be compared to the 41LM50 assemblage, but will instead be compared just to the experimental sample to validate the broad applicability of experimental replication as a nominal measure of Gahagan manufacture. Analysis of these additional debitage collections will be independent of any analyses already performed on those collections, and will be performed in accordance with TxDOT's protocol for chipped stone analysis (TxDOT 2010).

In the event that Gahagan manufacture is experimentally detectable, but evidence for its occurrence is absent at site 41LM50, the suggestion that inhabitants at the site expressed a Caddo cultural pattern, or were an unaffiliated foraging population involved in producing artifacts for export to Caddo populations to the east, cannot be supported. Thus, it would be reasonable to consider an alternative cultural pattern for the site's occupants. If this scenario should be realized, a literature review will be undertaken to characterize Late Prehistoric prairie culture pattern in the study region not fitting the current Prairie Caddo, Austin phase, or Toyah phase models. One specific goal of this study will be to reason that the presence of one proposed element of the existing Prairie Caddo model (i.e. Bonham-Alba points) is not unequivocal support for the validity or applicability of Shafer's (2006) Prairie Caddo model.

Such a finding would not be intended to arbitrarily rank the worth of various elements with respect to their ability to identify Caddo ethnicity (e.g., Gahagan bifaces vs. Bonham-Alba points), but rather to establish that (1) multiple lines of evidence are required to address the cultural pattern of prehistoric groups, and (2) any one "marker" of Prairie Caddo identity, as identified in Shafer's model, may as likely be associated with an alternative cultural pattern. Such a finding would be compatible with the blending of cultural traits and dilution of core cultural elements historically observed among indigenous groups at the margins

of their culture areas, in contested zones, and in borderlands.

The proposed literature review will involve professional reports that are directly relevant to the subject matter. It will focus on placing the Late Prehistoric occupations of site 41LM50 within a regional cultural-historical framework based on survey of extant data from other Late Prehistoric sites in the east-central Texas region. The review will incorporate Late Prehistoric sites in the study region with a predominance of Alba and/or Bonham-Alba (*sensu* Shafer 2006) arrow points in their chipped stone tool assemblage. The review will not focus on Late Prehistoric sites (or components of sites) in the study region with a predominance of Scallorn points and/or Friday bifaces that demarcate Austin phase assemblages, or Perdiz points and beveled knives that typify the later Toyah phase (e.g., Jelks 1962; Prewitt 1981, 1985). Late Prehistoric sites included in this review also should exhibit an absence or scarcity of ceramics (either of Caddo origin or the bone-tempered Leon Plain type assigned to the Toyah phase).

TRC shall compile data collected from the pertinent literature, producing a distributional map of sites with this suite of traits in an effort to define the geographic range of what may be an as-yet undefined and potentially distinct Late Prehistoric archeological culture. For comparison, the distributional map may, at the discretion of TRC, include the geographic distribution of traits associated with the Henrietta and Norteño complexes, as well as the proposed Prairie Caddo area. Using the distributional map, a model shall be developed that proposes an explanation for the known distribution of sites with the above suite of traits, as well as proposing settings or conditions that may favor the discovery of similar sites. TRC shall explicitly state whether Late Prehistoric material culture at site 41LM50 can be reasonably attributed to existing culture complexes as they are

currently understood (e.g., Austin, Toyah, Henrietta complex, Norteño complex, or Prairie Caddo), This predictive model will consider geological and geographical variables, ecological variables, natural and cultural site formation processes, and issues of preservation.

**5.6.4.2 Scenario Two: Gahagan Biface Manufacture Cannot Be Experimentally Detected**

If Gahagan biface production cannot be detected through experimental flake analysis, lithic assemblages from additional sites will not be

analyzed, an analysis of raw materials from site 41LM50 will not be performed, a literature review directed at developing a cultural-historical context for 41LM50 will not be performed, and a map of sites with the trait distributions described above will not be platted, and a predictive model will not be developed. A section will be included in the final report that discusses the difficulty in addressing multifaceted questions of cultural affiliation given limited material data. This discussion will also address the data needs for objectively testing the Prairie Caddo model and other alternative models of social identity during the Late Prehistoric period.

## **6.0 AN EXPERIMENTAL LITHIC ARTIFACT STUDY: DESIGNED TO TEST THE APPLICABILITY OF HARRY J. SHAFER'S MODEL OF THE PRAIRIE CADDO AT 41LM50**

Robert A. Ricklis and Shannon Gray

### **6.1 RATIONALE FOR THE EXPERIMENTAL STUDY**

In 2006, Harry J. Shafer proposed, in a monograph entitled *People of the Prairie: A Possible Connection to the Davis Site Caddo*, that Caddo people inhabited the prairie environments of central, east-central, and north-central Texas during the early part of the Late Prehistoric period (i.e., contemporaneous with the Caddo occupation of their heartland in the east Texas woodlands, including at the large George C. Davis site [41CE19] on the Neches River in Cherokee County, Texas, ca. A.D. 900-1300). Shafer suggested that the area occupied by what he termed the “Southern Prairie Caddo” (Shafer 2006:5) extended from the margins of the east Texas woodlands westward as far as the central part of Lampasas County (Figure 6-1). According to Shafer (2006), the presence of people of Caddoan culture and ethnicity on these prairies is archeologically indicated through a series of artifacts of diagnostically Caddoan technological styles. These include: ceramics of recognizably Caddoan typology, or with decorative and other attributes closely resembling pottery from the Caddo heartland; specific types of flaked-chert debitage such as Bonham-Alba arrow points and Gahagan bifaces; deer metapodial beamers (hide dehairing tools); and bone needles (Shafer 2006:10-24).

Of the three sites reported here, only 41LM50 yielded any of these postulated Southern Prairie Caddoan diagnostic artifacts. Arrow points identified as Alba and Bonham types, considered by

Shafer to be a relevant Prairie Caddoan diagnostic item, were recovered during excavation. As discussed earlier in our research design (see Chapter 5.0), no Gahagan bifaces were recovered, and aboriginal ceramics, bone needles and beamers are absent as well. Lithic debitage, present in limited quantities, was collected for analysis.

The demonstrated presence of Bonham-Alba arrow points and Gahagan bifaces at other sites on the prairies of east-central Texas, such as J. B. White (Gadus et al. 2006) and Hoxie Bridge (Bond 1978), suggests that these items are indeed recurrent traits in Late Prehistoric assemblages. Shafer (2006) points out how current debitage analysis strategies do not take into account correlation of technological style and debitage characteristics. He suggested the reduction strategy used to make Gahagan bifaces may have been sufficiently specialized to leave distinctive characteristics in the debitage from production:

An approach used to identify the production area of Gahagan knives is to factor out the particular technological style of biface reduction from the excavated lithic sample through core analysis (biface sequence), platform preparation, and presence of biface thinning debitage that fits that technological style of biface reduction. All of these artifact classes would constitute the correlates of the Gahagan biface system.

The approach using technological style for the Gahagan system is necessarily qualitative in part, and requires critical knowledge of biface technologies and how to recognize the respective components. The idea is to introduce testable assumptions for material culture analysis. The real key to understanding the Gahagan technological system rests with the technological style of platform preparation and biface thinning skill.

Current methods of lithic analysis in central Texas obscure identifying the presence of such a technological system, and essentially identify



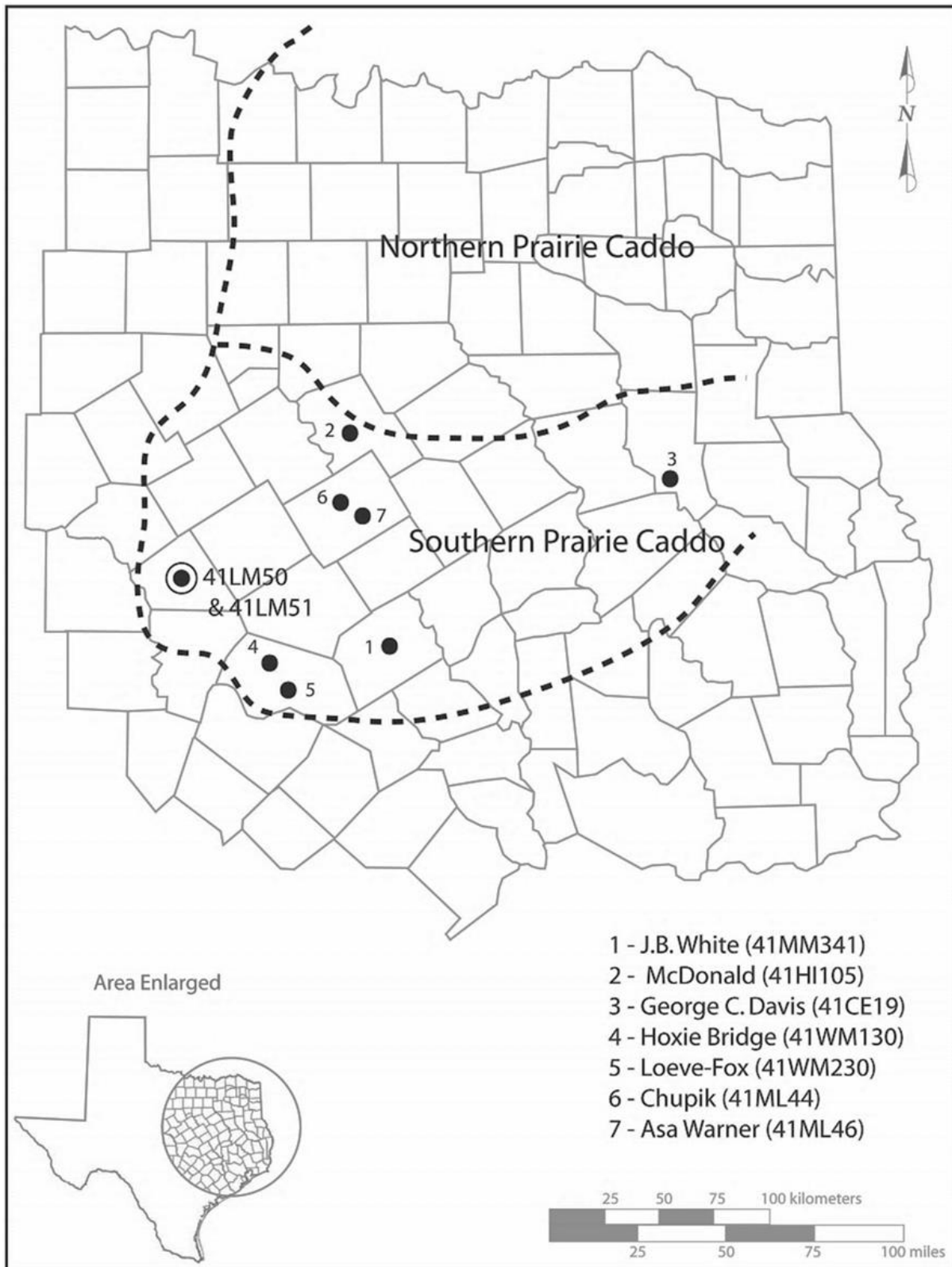


Figure 6-1. Map illustrating Shafer's (2006) proposed Prairie Caddo geographic areas.

only the type at best (Gahagan or Friday knife) or “thin biface or stage four biface” at worst in the descriptive analysis. The other components of the technological system used to define the technological style are lost in the segregation of bifaces from debitage and with the emphasis on describing reduction stages in overall biface assemblages and trends in debitage analysis. Neither the bifaces nor debitage are customarily related to specific technological systems.

Current methods of lithic analysis are not sufficient in the manner of organization to recognize Gahagan manufacturing localities and need to take a more systemic approach. Platform type and method of detachment will become obvious as the material is sorted out and can be related to the appropriate stages of reduction at the time of their removal. In other words, trends in the debitage should show that, as biface thinning progresses, platforms become more acute and the frequency of hard-hammer (cone-initiation) flakes decreases at the expense of biface thinning flakes (flakes with bending initiation). As the biface becomes thinner, the length-thickness ratio of the biface thinning flakes decreases, and (this is important), flakes become *flatter in profile than the typical arched profile of thinning flakes removed from dart points* (Shafer 2006:27-28; emphasis added).

Shafer (2006:27-28) suggests that technological requirements of producing relatively thin, flat bifaces (such as Gahagans) might result in debitage containing relatively flat biface thinning flakes. However, he cautions that “One cannot necessarily expect the debitage alone to reveal a location of Gahagan manufacture.” and states “it has yet to be shown that biface thinning flakes are diagnostic of technological styles in Late Archaic and Late Prehistoric sites in central Texas, despite the fact that some may be.” To date, however, no detailed analysis has been undertaken to determine whether debitage diagnostic of Gahagan biface production is identifiably present at Late Prehistoric sites.

As we noted in Chapter 5.0, we also posited that relatively flat biface thinning flakes might be a diagnostic by-product of Gahagan biface production. The essential premise here is flat bifacial thinning flakes should result from production of flat bifaces. Gahagans, being relatively flat, should have bifacial thinning flakes that are also relatively flat, perhaps distinctively so. Therefore, the research question is summarized thusly: can bifacial thinning flakes from Gahagan manufacture be archeologically identified via assessment of arc curvature in order to indicate areas of Gahagan biface production?

### **6.1.1 Addressing the Research Question: Process**

Shafer (2006) suggests a systematic approach to debitage analysis incorporating technological style markers could address key questions in lithic manufacturing. He postulates that technological requirements to produce thin, flat bifaces may lead to biface thinning flakes with an identifiably flatter profile. The presence of such flakes could indicate areas of biface production, and if differentiated enough, perhaps even the typology of the bifaces produced there. Shafer (2006) suggests Prairie Caddoan diagnostic Gahagan bifaces are relatively flat, and production of such could result in distinctively flatter bifacial thinning flakes. Therefore, the recognition of these qualities of arc curvature within debitage assemblages could therefore identify production locations for Gahagan bifaces.

In order to assess Shafer’s (2006) suggestion that biface thinning flakes could potentially be distinguished due to the differences in technological styles of production of different bifaces, an experimental approach was devised. We proposed this experimental study to TxDOT: to analyze debitage produced by replication of bifaces to test whether debitage from Gahagan manufacture was potentially isolatable from that of other bifaces by qualities such as relative flatness. TxDOT

agreed to produce biface replications and supply us with all resultant debitage for analysis. In addition to Gahagan bifaces, TxDOT also included in the replications two other common types of Late Prehistoric thin bifaces: Friday bifaces and Harahey knives (four-beveled bifaces). This provided a contrastive sample in order to determine if debitage from Gahagan biface production was distinguishable within the replicated debitage.

Measurements were made on curated archeological specimens of all three types, in order to assess the hypothesis that Gahagan bifaces are, on average, relatively thinner/flatter than specimens of other Late Prehistoric biface types, as previously suggested by Shafer (2006). If so, then late-stage thinning debitage from Gahagans might be empirically distinguishable from debitage resulting from production of the other two types.

The experimental bifaces were to be measured to verify each fell within the ranges described by the metrics from the archeological samples. If the experimental bifaces were within the archeological ranges, then the experimental debitage could be presumed to be consistent with archeological debitage, and would be analyzed. As part of the analysis, the experimental biface thinning flakes would be separated and the relative flatness assessed. If results indicated that the experimental debitage was distinguishable between types, then this would indicate that archeological debitage might be potentially distinguishable as well.

## **6.2 METRIC ANALYSES OF ARCHEOLOGICAL EXAMPLES OF LATE PREHISTORIC BIFACES**

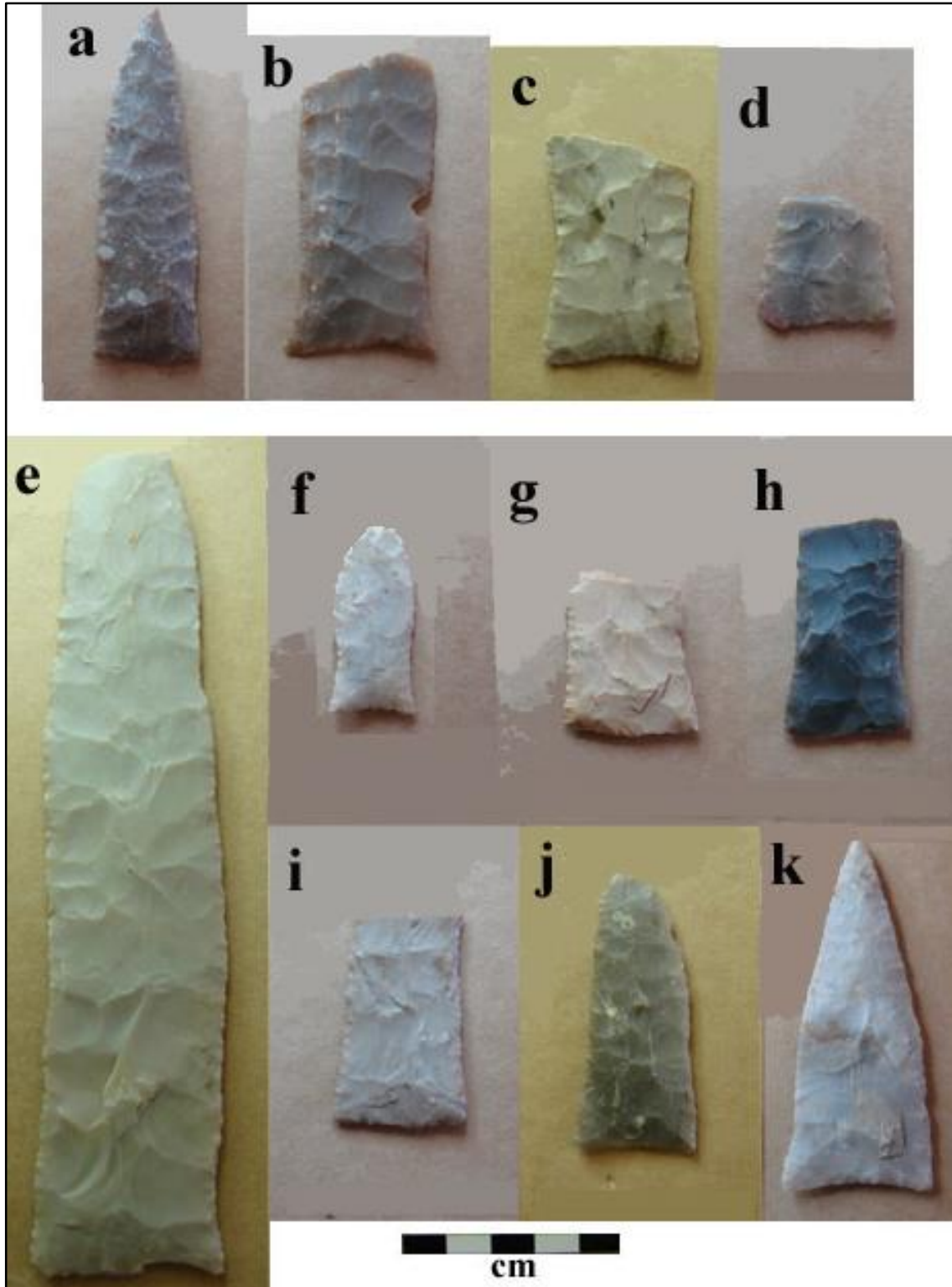
The senior author visited the TARL at the University of Texas, Austin, on November 24, 2011 to collect metric data on a sample of three types of Late Prehistoric bifaces: Gahagan bifaces; Friday bifaces; and Harahey/four-beveled knives (see Figures 6-2 through 6-4). Since all three types have

established Late Prehistoric cultural affiliations (Turner et al. 2011), analysis of debitage resulting from the replication of the three types would presumably permit us to assess whether or not debitage from prehistoric production of Gahagan bifaces in particular could be differentiated from debitage from biface reduction of other types in a given Late Prehistoric context. All 35 prehistoric specimens comprising this analyzed sample are from well-documented archeological contexts.

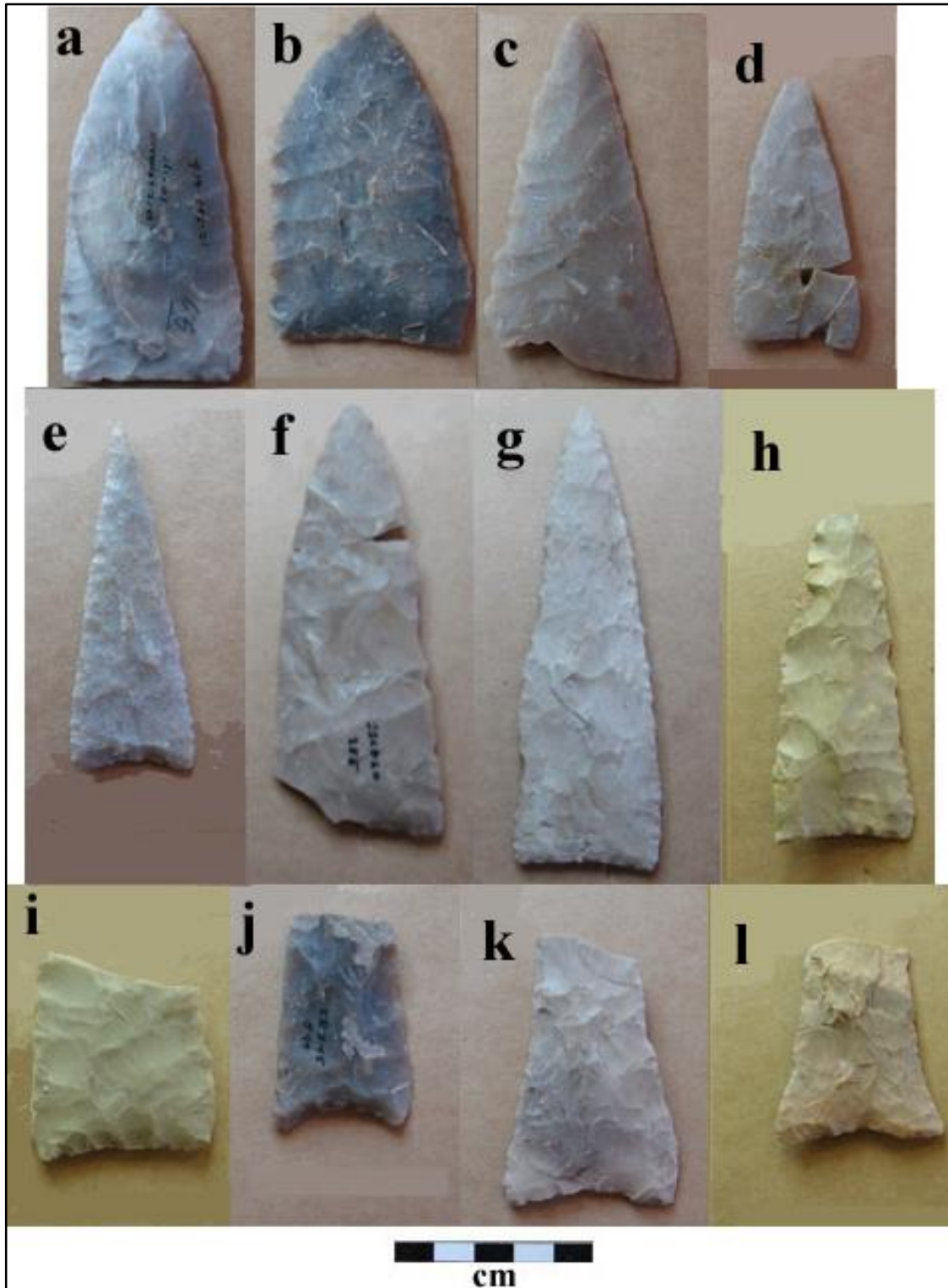
The aim of the sampling was to determine the relative thickness within each sampled type, via width-to-thickness ratios (W:T), and to determine if the six replications (two of each type) produced by TxDOT staff archeologist Christopher Ringstaff fell within the range observable on the measured prehistoric archeological specimens. As discussed above, this determination permits assessment of the suitability of the debitage produced during the replication work for reliable comparisons with archeological debitage from the Late Prehistoric component at 41LM50 in Lampasas County. Ultimately, the goal of this study was to determine if the debitage from Gahagan biface production is potentially distinguishable in archeological collections, and if so, applying that methodology to assess if site 41LM50 is, or is not, potentially representative of on-site production of Gahagan bifaces. The ability to identify Gahagan debitage within the archeological context of 41LM50, and potentially other sites, would help to construct a model of these sites as part of a possible system of production and exchange of Gahagan bifaces by/with Caddo people, as hypothesized by Shafer (2006).

### **6.2.1 Methods and Procedures: Archeological Sampling**

At the senior author's request, Laura Nightengale, former Head of Collections at TARL, kindly assembled a sample of each of the three types of bifaces for use in this study from various sites in central and east Texas, and made them available for

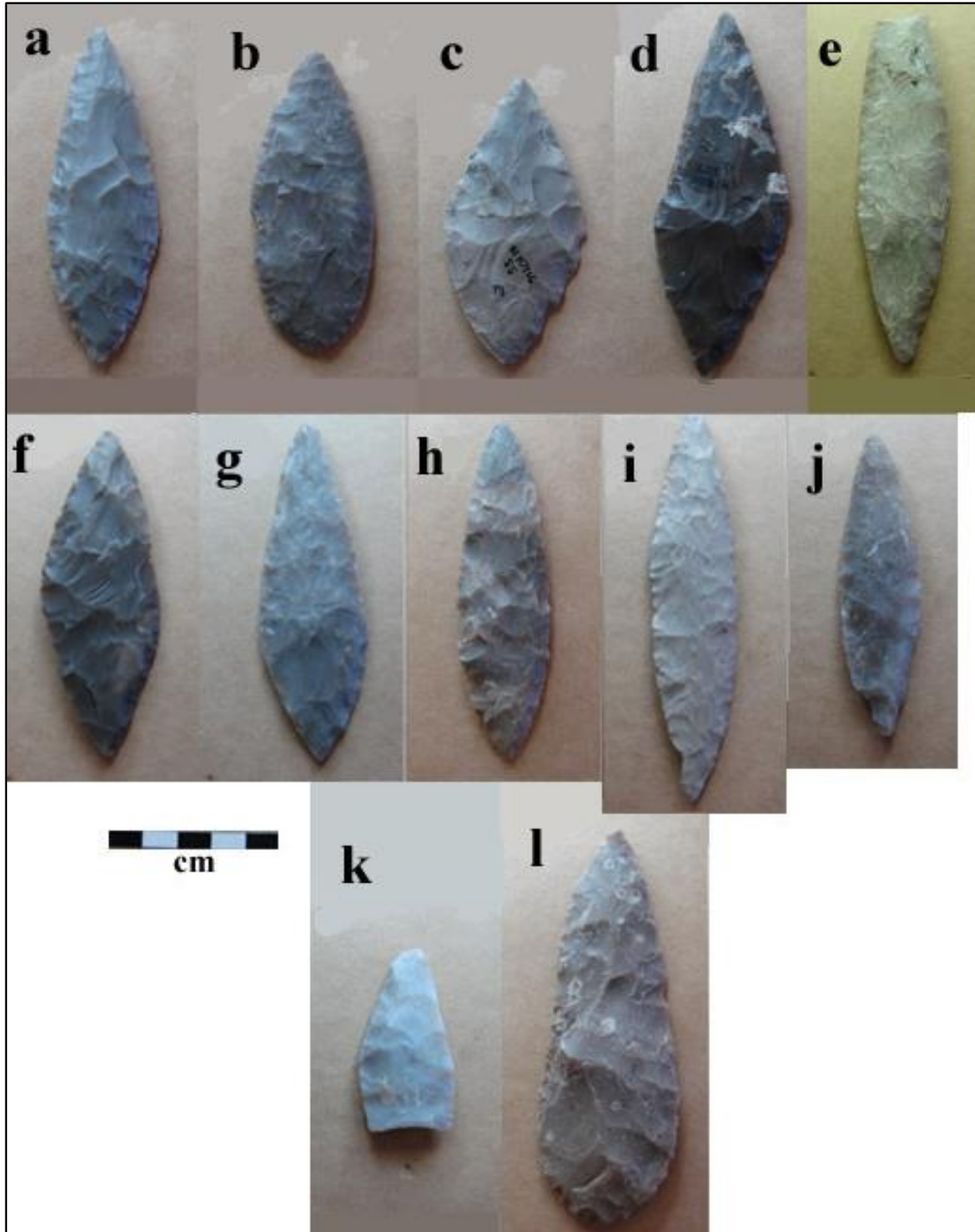


**Figure 6-2.** The 11 Gahagan bifaces from archeological context used in the present study. Curated in the collections of the Texas Archeological Research Laboratory (TARL), The University of Texas at Austin. Photographs by R. Ricklis with permission of TARL.



**Figure 6-3.** The 12 Friday bifaces from archeological context used in the present study. Note: These bifaces are curated in the collections at Texas Archeological Research Laboratory (TARL), The University of Texas at Austin. Photographs by R. Ricklis with permission of TARL.





**Figure 6-4.** The 12 Harahey/four-beveled knives from archeological context used in the present study. Note: These knives are curated in the collections at Texas Archeological Research Laboratory (TARL), The University of Texas at Austin. Photographs by R. Ricklis with permission of TARL.

**Table 6-1. Metric Data (in mm) of 35 Late Prehistoric Bifaces in TARL Collections Compared to Experimental Replicated Bifaces.**

Type	Figure #	Max Length	Max Width	Max Thick	W:T Ratio	T:W Ratio
Gahagan	6-2, a	100.11	27.98	7.74	3.61	0.277
	6-2, b	74.48*	37.15	6.17	6.02	0.166
	6-2, c	54.59*	36.98	5.51	6.71	0.149
	6-2, d	31.45*	32.78	3.63	9.03	0.111
	6-2, e	182.3*	41.49	7.72	5.37	0.186
	6-2, f	42.63*	19.90	4.52	4.40	0.227
	6-2, g	38.89*	31.01	5.29	5.86	0.171
	6-2, h	55.62*	31.98	6.53	4.90	0.204
	6-2, i	50.11	30.03	5.62	5.34	0.187
	6-2, j	66.10	28.57	6.42	4.45	0.225
	6-2, k	120.60	50.04	7.00	7.15	0.140
<b>Gahagan Average</b>			<b>33.45</b>	<b>6.01</b>	<b>5.71</b>	<b>0.186</b>
Exp 12 Gahagan	6-5	109.19	42.59	9.61	4.43	0.226
Exp 14 Gahagan	6-5	89.59	37.94	8.82	4.30	0.232
<b>Exp Gahagan Average</b>			<b>40.27</b>	<b>9.22</b>	<b>4.37</b>	<b>0.229</b>
Friday	6-3, a	117.50	55.10	9.90	5.57	0.180
	6-3, b	96.40	54.10	6.40	8.45	0.118
	6-3, c	108.06	56.37	8.53	6.61	0.151
	6-3, d	79.27	35.55	7.09	5.01	0.199
	6-3, e	83.95	30.63	6.42	4.77	0.210
	6-3, f	109.70	40.85	8.13	5.02	0.199
	6-3, g	110.65	34.58	7.44	4.65	0.215
	6-3, h	77.81	32.76	10.30	3.18	0.314
	6-3, i	53.27*	45.53	8.14	5.59	0.179
	6-3, j	53.79*	33.79	8.32	4.06	0.246
	6-3, k	64.59*	41.45	7.95	5.21	0.192
	6-3, l	49.13*	40.19	10.01	4.01	0.249
<b>Friday Average</b>			<b>41.74</b>	<b>8.22</b>	<b>5.18</b>	<b>0.204</b>
Exp 6 Friday	6-5	86.79	41.67	8.27	5.04	0.198
Exp 15 Friday	6-5	95.16	40.23	8.49	4.74	0.211
<b>Exp Friday Average</b>			<b>40.95</b>	<b>8.38</b>	<b>4.89</b>	<b>0.205</b>
Harahey	6-4, a	93.84	31.38	8.22	3.82	0.262
	6-4, b	84.47	34.26	7.23	4.74	0.211
	6-4, c	82.64	40.58	7.72	5.26	0.190
	6-4, d	114.35	41.11	8.99	4.57	0.219
	6-4, e	118.21*	29.53	8.04	3.67	0.272
	6-4, f	100.02	35.05	10.04	3.49	0.286

Note: The Figure # Column Indicates Photo Location and Identification in this Report. Asterisks Denote Fragmented Specimens. Averages are not included for Length as Fragmented Specimens Would Introduce Data Skew.

Type	Figure #	Max Length	Max Width	Max Thick	W:T Ratio	T:W Ratio
Harahey	6-4, g	103.19	32.96	7.71	4.27	0.234
	6-4, h	100.36	27.03	7.39	3.66	0.273
	6-4, i	116.88	25.17	9.27	2.72	0.368
	6-4, j	87.57	23.47	9.91	2.37	0.422
	6-4, k	53.63*	27.13	9.04	3.00	0.333
	6-4, l	114.95	39.88	12.05	3.31	0.302
<b>Harahey Average</b>			<b>32.30</b>	<b>8.80</b>	<b>3.74</b>	<b>0.281</b>
Exp 2 Harahey	6-5	121.00	41.03	9.99	4.11	0.243
Exp 3 Harahey	6-5	156.10	48.33	13.86	3.49	0.287
<b>Exp Harahey Average</b>			<b>44.68</b>	<b>11.93</b>	<b>3.80</b>	<b>0.265</b>

Note: The Figure # Column Indicates Photo Location and Identification in this Report. Asterisks Denote Fragmented Specimens. Averages are not included for Length as Fragmented Specimens Would Introduce Data Skew.

analysis at TARL. Metric data were obtained on a total of 35 curated archeological specimens comprised of 11 Gahagan bifaces, 12 Friday bifaces, and 12 Harahey (four-beveled) knives. Specimens were identified by type on the basis of diagnostic morphology, using the standard typology reference, *Stone Artifacts of Texas Indians* (Turner et al. 2011) in addition to the senior author's own experience in Late Prehistoric Texas bifaces. Each biface specimen was photographed, and these photos are reproduced here as Figures 6-2 through 6-4. At least two of the Gahagan specimens (Figure 6-2, e and h) were pictured in Shafer's monograph (2006:20) as representatives of the type.

In all cases, the measured specimens were selected for their morphological integrity. Distal breaks are present on 13 of the 35 bifaces, however, the damage was not extensive enough to preclude reliable measurements of relevant dimensions, as the maximum width and maximum thickness were still intact and measurable. Additionally, the specimens selected had not been subjected to extensive use, reworking, or resharpening that significantly altered their original form, and therefore affected their original widths and thicknesses.

In the case of Harahey knives, the diagnostic four-beveled form is considered to result from resharpening, but the sampled specimens were perceived to retain all or most of their original midsection width and thickness.

Measurements were made using a Mitutoyo digital caliper, with readings recorded to the nearest hundredth of a millimeter (mm). The artifacts were photographed with a Sony digital camera. Comparable measurements were made on the six replicated bifaces produced by Mr. Ringstaff.

The metric data is presented for archeological and experimental specimens (see Tables 6-1 and 6-2). Preliminary assessment of archeological samples had suggested Gahagan bifaces were thinner comparative to other Late Prehistoric biface types Fridays and Haraheys. The metric data collected from the curated specimens of archeological Gahagan, Friday, and Harahey bifaces seemed to indicate that Gahagans were, on average, thinner (6.01 mm) than Friday (8.22 mm) and Harahey (8.80 mm) types, consistent with Shafer's (2006) theory that the late-stage thinning flakes produced during the manufacture of Gahagans should therefore correlate similarly, and be, on average, flatter, with less pronounced arcs/curvatures than comparable flakes resulting from the production of the other two types.



**Table 6-2. Characteristics of Six Replicated Bifaces Made by C. Ringstaff of TxDOT.**

<b>Biface Type</b>	<b>Exp. #</b>	<b>Material Form</b>	<b>Material</b>	<b>Max. Length</b>	<b>Max. Width</b>	<b>Max. Thick</b>	<b>W:T Ratio</b>
Harahey	2	Nodular	Mottled gray chert	121.0	41.03	9.99	4.11
Harahey	3	Tabular	Dark gray chert	156.1	48.33	13.86	3.49
Friday	6	Tabular	Georgetown chert	86.79	41.67	8.27	5.04
Friday	15	Nodular	Light gray chert	95.16	40.23	8.49	4.74
Gahagan	12	Nodular Macroflake	Mottled gray chert	109.19	42.59	9.61	4.43
Gahagan	14	Nodular Macroflake	Medium gray chert	89.59	37.94	8.82	4.30

However, biface thickness cannot be considered independently of the interrelated variable of width. The key attribute required in our current work is the relative thickness of each type of biface, and this must be expressed as a ratio in order to account for the interrelated variables of thickness and width. Utilization of the W:T ratio allows direct comparatives of relative thickness of bifaces while accounting for size variations amongst those bifaces. When width is equalized to a constant across the bifaces, the relative thickness is calculated for that equivalent width, therefore, the smaller the resulting W:T ratio, the thinner the biface. For ease of future cross-study comparatives, both width-to-thickness (W:T), as well as thickness-to-width (T:W) ratios, were calculated for this study. T:W ratios are utilized for comparisons of relative width.

**6.2.2 Replicated and Archeological Specimen Range Comparisons**

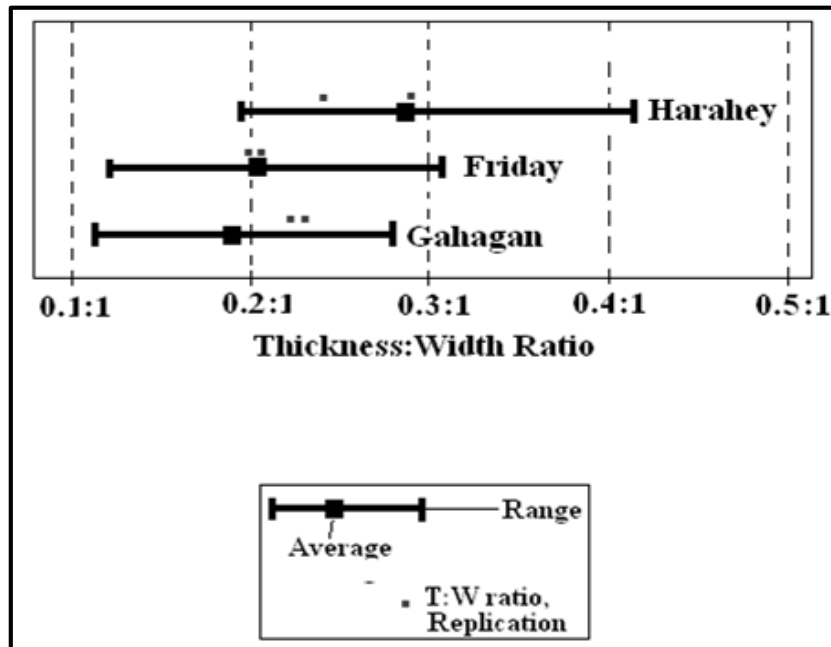
The biface experimental replications are illustrated in Figure 6-6, and the metric data and characteristics for these specimens are presented in Tables 6-1 and 6-2. The metric results of the prehistoric and replicated bifaces are graphically compared in Figure 6-5. If the finished replicated

biface types fell within the range for relative thickness described by the sampled archeological bifaces, then theoretically, debitage generated from production of those replications would therefore potentially display characteristics similar enough to be within the range of the debitage resulting from prehistoric manufacture of this type. The two replicated Gahagan bifaces have T:W ratios of 0.226:1 and 0.232:1, both within the range of the archeological specimens (0.111:1 to 0.277:1). W:T ratios of 4.3 and 4.43, are well within the archeological sample range of 3.62 to 9.03.

The two replicated Friday bifaces have T:W ratios of 0.198:1 and 0.211:1, both within the range (0.118 to 0.314) and for the archeological sample. W:T ratios of 4.74 and 5.04 are within the archeological range of 3.18 to 8.45.

Replicated Harahey knives have T:W ratios of 0.243:1 and 0.278:1, both within the archeological range (0.190:1 to 0.422:1). W:T ratios of 3.49 and 4.11 are within the archeological range of 2.37 and 5.26.

Having established that the experimental replicated bifaces fell within the ranges described by the archeological specimens, it was presumed that the



**Figure 6-5. Graphic presentation of the curated archeological Gahagan, Friday, and Harahey bifaces compared to the six replicated specimens.** Note: This diagram compares thickness-to-width (T:W) ratios (range and average) of the curated archeological Gahagan, Friday, and Harahey bifaces, compared to T:W ratios of each of the six replicated specimens indicated by dots plotted above the range.

debitage created during the replication production of these replications was reasonably similar to debitage resulting from prehistoric manufacture of those three biface typologies. Thus, the debitage created by manufacture of these replications is likely sufficiently similar to prehistoric debitage for the present analytical purposes.

It was noted that the relative thickness of the Friday replicated bifaces was closer than the Gahagan replications to the average of the archeological Gahagan bifaces. The bifacial thinning flakes generated by the production of the Friday biface replications were therefore expected to be similar to bifacial thinning flakes from production of prehistoric Gahagan bifaces – perhaps even more so than that of the replicated Gahagans (under the early working assumption, later proved incorrect, that the fairly subtle thickness differences of the resultant tools are discernibly reflected in the debitage).

Although the relative thicknesses of the replicated Gahagans and Fridays do not precisely match the means of the archeological specimens should not be taken as problematical, given that the ranges of these ratios for the two types largely overlap among the prehistoric specimens, and that there is a good deal of overlap in the overall morphology of specimens of the two types (Figure 6-7, as well as illustrated specimens in Shafer 2006:20, Figure 6).

### 6.3 ANALYSIS OF THE EXPERIMENTAL DEBITAGE

Having verified the relative thicknesses of the replicated bifaces fall within the range of those of the archeological specimens among all three types of bifaces, the next step was to perform detailed analysis of the experimental debitage created via the replication of six bifaces by Chris Ringstaff in order to test the hypothesis that discernible differences in the characteristics of the debitage may exist and be detectable in archeological

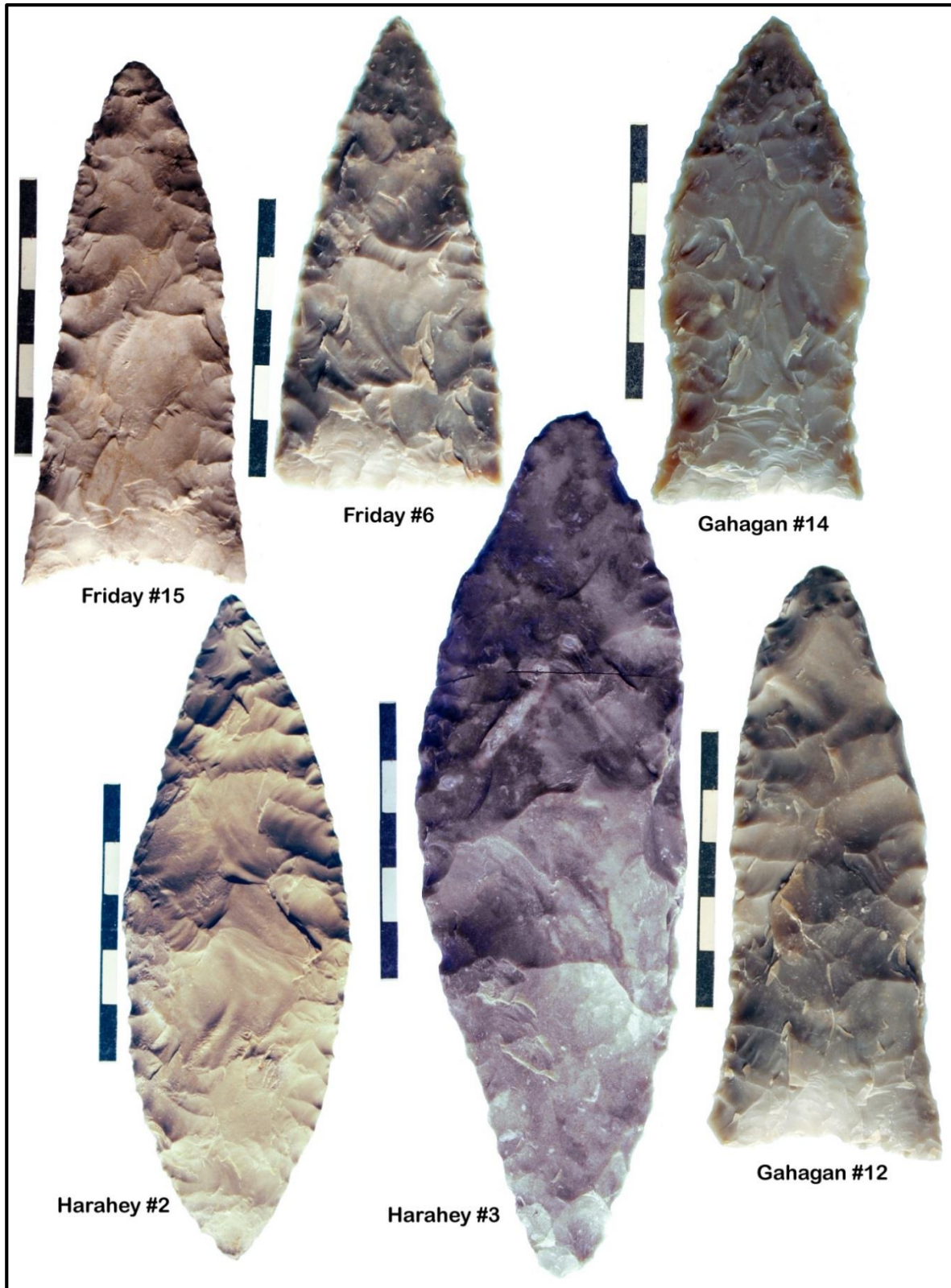
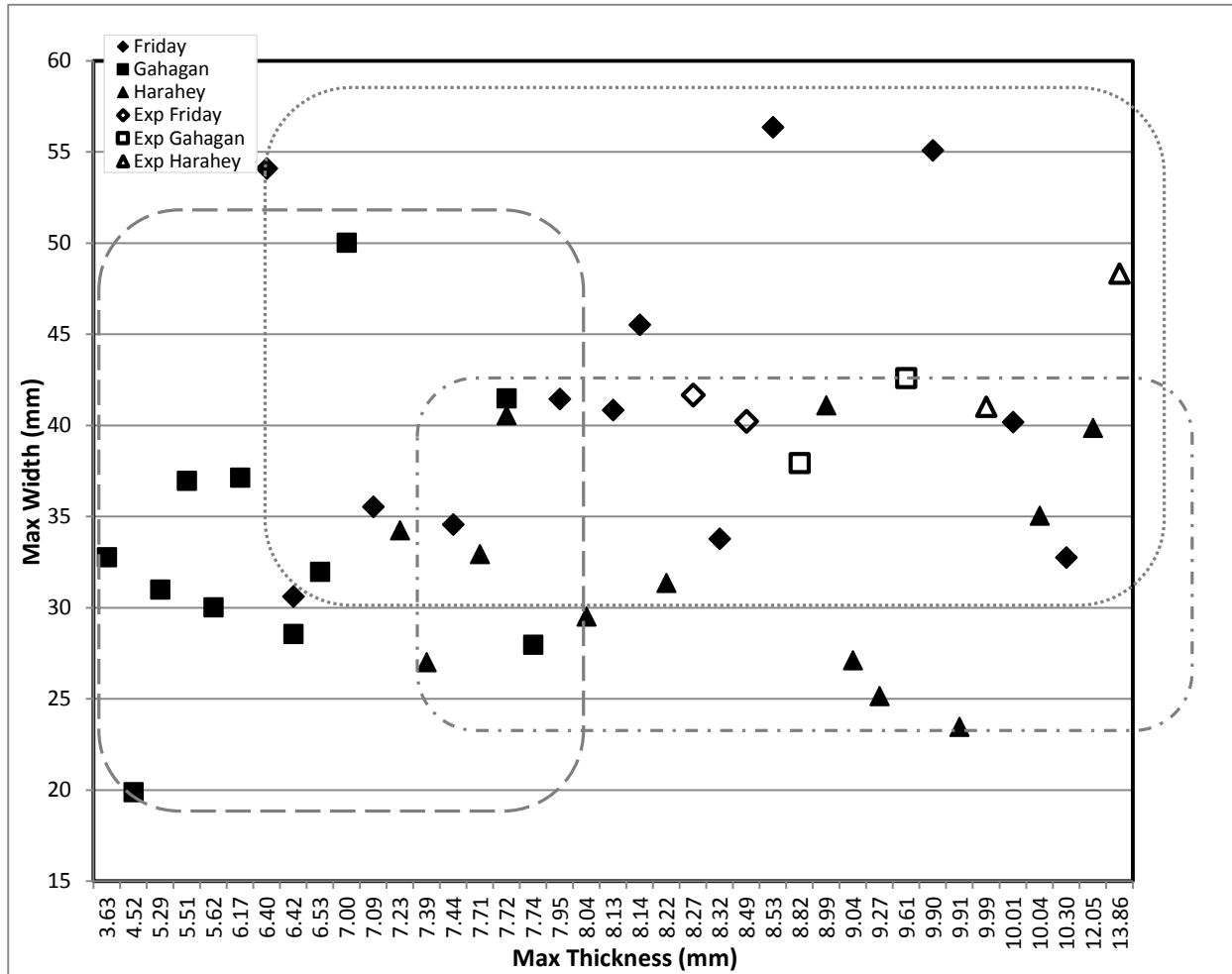


Figure 6-6. Replications of three Late Prehistoric biface types made by TxDOT archeologist, Chris Ringstaff (photographs by M. Quigg).



**Figure 6-7. Distributional groupings of width and thickness variables for archeological specimens by biface type.** Note: the thickness and width are plotted as independent variables to highlight differential distribution when considered separately. A large degree of overlap between the three types is evident, even when considered thusly.

assemblages. In particular, the purpose of this work was to determine if the debitage (flakes and flake fragments) generated in the production of each of the three types has a definable ‘signature’ in terms of diagnostic flake attributes.

Theoretically, if the debitage from a particular type has corresponding flake-type/attribute characteristics, it should then theoretically be possible to apply these parameters to archeological collections in order to potentially identify the production of a given type through analysis of debitage samples from Late Prehistoric contexts.

In the following sections, the methods utilized for this purpose are first summarized then discussed in detail.

### 6.3.1 Debitage Analysis: Methods Overview

Following TxDOT’s Chipped Stone Analytical Protocol (2010), the basic sequence of analytical procedures for the replicated debitage was as follows:

1. Size sorting of all debitage from each experimental specimen by passing the materials through a series of wire-mesh screens

of progressively smaller gauges (ranging from 1 inch to ¼ inch). Categories as stipulated in the protocol were assigned:

- 01 1 inch (26.5 mm)
- 02 ¾ inch (19.0 mm)
- 03 ½ inch (12.5 mm)
- 04 ¼ inch (6.4 mm)

2. Specimens in each size group were then sorted/grouped according to percentage of the dorsal surface that still retained cortex. Percentages were estimated according to five range categories as stipulated in TxDOT protocol:

- 00 0 percent cortex
- 01 1-25 percent cortex
- 02 26-50 percent cortex
- 03 51-75 percent cortex
- 04 76-100 percent cortex

3. Within each of the five cortical categories, the specimens were further sorted according to attributes of the striking platforms. The protocol lists the following platform characteristics and corresponding numerical codes:

- 00 Indeterminate platform
- 01 Cortical platform
- 02 Single-faceted (flat) platform
- 03 Double-faceted (dihedral faceted) platform
- 04 Multiple-faceted platform
- 05 Abraded platform (not applicable to the current study)
- 06 Complex / bifacial platform
- 07 Rejuvenated platform (not applicable to the current study)
- 08 Missing platform / flake fragment

4. Degrees of curvature were calculated for all whole bifacial thinning flakes from each specimen.

a. Flake length (L) and maximum height (H) were measured for all whole bifacial

thinning flakes. L:H ratio was calculated for each flake.

b. Resulting ratios of L:H by flake were grouped by specimen and statistically assessed to determine if any statistically significant differences for degrees of curvature existed in the replication debitage, whether between individual specimens or across type groupings.

### 6.3.2 Methodological Considerations and Discussions

It is important to note that the methods of analysis were necessarily tailored to meet the specific requirements of this project due to the nature of the experiment and the goals of the research design. Some categories and steps taken in analysis of prehistoric collections were not applicable to analysis of replications. Additionally, since the experiment is aimed at determination of characteristics not normally recorded in standard analysis, with TxDOT's approval, additional methods of analyses were applied in order to attempt to investigate the intriguing suggestion set forth by Shafer (2006) that manufacture of different biface types may result in distinguishable patterns of resulting debitage that potentially could be identified in analysis of archeological collections. All debitage was categorized by Chris Ringstaff by parent raw material classification (nodular, tabular, macroflake) prior to analysis. As this information was already known, the debitage did not require analysis aimed at determining the form of the parent material. Likewise, thermal alteration/treatment was known to have been applied to all experimental replications and was not an applicable category for this study.

As previously indicated in the methods overview, certain categories of platform types were not relevant to the current study. Since the replicated bifaces have not been used as tools and have not been rejuvenated, the category of rejuvenated

platform (07) is not applicable here. The Abraded platform (05) category was also not relevant to the present analysis since abrasion was found only in combination with other platform attributes, such as Multiple-faceted (04). To assign such a flake to the Abraded platform (05) group, rather than the other platform groups present, would mask the representation of those categories within the sample. Thus, for the sake of the most accurate representation of other platform types, the Abraded (05) category was not utilized during this analysis. These observations suggest that perhaps abrasion should be treated as a *secondary* platform attribute, recorded as a subset of other platform categories, rather than a primary platform type, as is called for in the current version of the protocol (TxDOT 2010). During assignment of platform type, a high percentage of the flakes were necessarily assigned to the indeterminate platform (00) category, either because they had crushed platforms, or because the platforms were so thin as to have no recognizable facet characteristics.

Especially relevant in regards to assignment of platform type is the methodology followed for fragmentary flakes. Proximal flake fragments were assigned based on the platform type present. Distal flake fragments, lacking platforms, were grouped under the missing platform (08) category. However, since this category is not a platform type, but rather a lack of it, these distal flake fragment counts are noted in the table, but are not included in calculations nor when discussing platform type representation.

It is also important to note that cortex percentage is an aspect of the flake dorsal surface only, rather than the flake in its entirety. Cortex confined to the platform surface of a flake, with no cortex upon the dorsal surface, would therefore still be considered a cortical flake, as per the TxDOT protocol (2010).

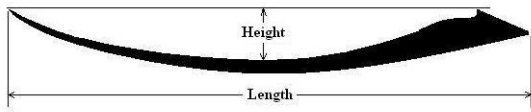
A final aspect of analysis was directed toward examination of attributes of the bifacial thinning flakes present in the experimental debitage. Bifacial

thinning flakes, as defined in TxDOT's Protocol for Lithic Analysis, (2010), are removed during the final stages of biface manufacture, and display the complex platforms associated with precision platform preparation. Within the experimental debitage, a total of 46 flakes met these criteria; however, only 31 of those flakes were whole. These 31 whole flakes formed the bifacial thinning flake experimental data set for this analysis.

In order to examine the specific attributes of the bifacial thinning flakes necessary for this study, the analytical procedure used is an addition to those analytical steps in the protocol, utilized with prior approval from TxDOT (J. Barrett, personal communication, 2012). Specifically, the goal here was to attempt a controlled replication study to test Shafer's (2006) suggestion that Gahagan production debitage might be distinguishably flatter, with less pronounced arc curvatures, than comparable flakes resulting from production of other biface types.

Degrees of curvature are a comparison of the degree of flake arch as it relates to the length of the flake. In order to describe metrically the curve and relative 'flatness' of the flake profile, Shafer uses the term "length-thickness ratio" (2006:28). For clarity, we have opted to describe the flake profile in terms of flake length comparative to flake arc height to describe the curvature while avoiding potential confusion between the thickness of the flake profile versus the thickness of the flake material. The comparative ratio is therefore termed the flake-length-to-flake-arc-height ratio, or length-to-height (L:H) ratio for short. Utilization of the L:H ratio allows direct comparatives of the arc of curvature by individual flakes while accounting for size variations between those flakes. When height is equalized across the flakes, the length is calculated for that equivalent height, therefore, the greater the resulting L:H ratio, the 'flatter' the flake.

In order to determine if there was any consistent difference in the average degree of curvature



**Figure 6-8. Idealized profile of a bifacial thinning flake and the axes along which the length and the arc height of the flake were measured.**

exhibited by Gahagan bifacial thinning flakes compared to those from Friday and/or Harahey bifaces, flake length and maximum arc height was measured on all whole thinning flakes ( $N = 31$ ) represented in the experimental debitage from production of the six replicated bifaces.

To determine the maximum arc height, the space between the maximum concavity on the ventral side of each thinning flake and a straight line formed by a straight-edge placed against the outer edge of the flake platform (on its ventral side) and the distal end of the flake was measured, as shown in Figure 6-8. These measurements were obtained by the use of a digital caliper and recorded to the nearest one-hundredth of a millimeter.

The resulting measurements were then used to calculate the flake-length:arc-height (L:H) ratio for each flake, on the basis of which the average length:height (L:H) ratio for all specimens within the sample from each replicated biface could be determined and the results from all six specimens could be compared.

### **6.3.3 Results of Experimental Debitage Analysis, and Comparison to 41LM50 Debitage**

#### ***Flake Size Sorting***

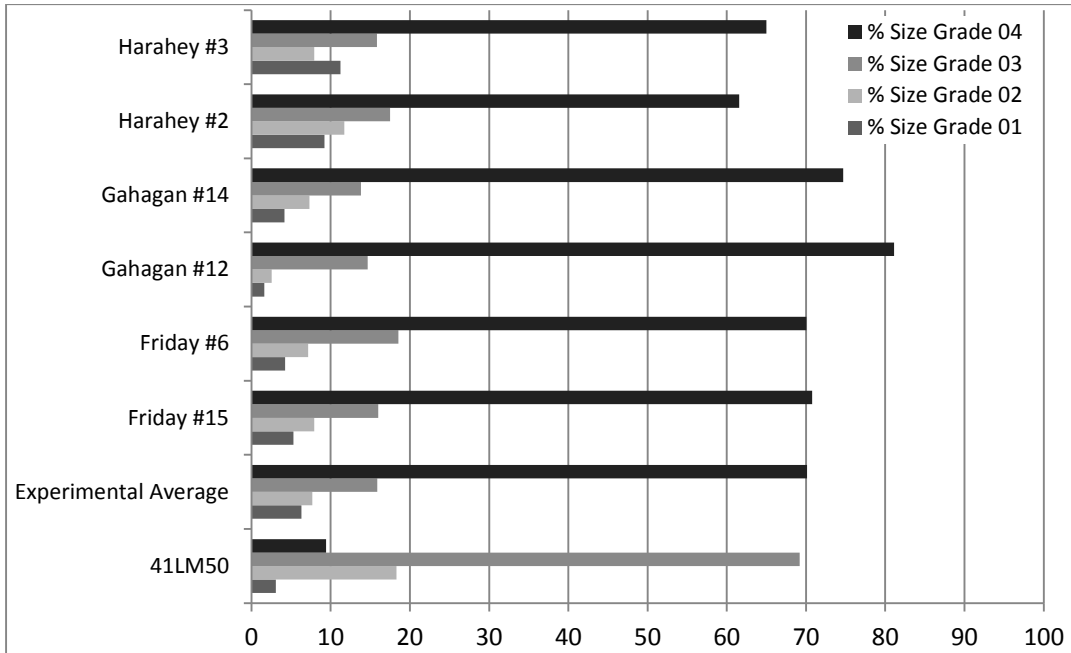
As per the standard procedure followed for all lithic debitage analysis under TxDOT protocol (2010), the debitage from the experimental bifaces was initially size sorted into the previously mentioned size grade categories. In all cases, by far the largest quantity of flakes for each replication was  $\frac{1}{4}$  inch and smaller. The biface manufacturing process requires more precision and control with flake

removal towards the latter stages of manufacture. The precision required results in smaller flakes removed and the resultant greater number of flakes from this finishing stage. This is quite evident in the experimental debitage, where slightly more than 70 percent ( $N = 2,176$ ) of the total flakes produced during the manufacture of the experimental bifaces ( $N = 3,103$ ) were  $\frac{1}{4}$  or smaller (Size Grade 04) finishing stage flakes (Figure 6-9).

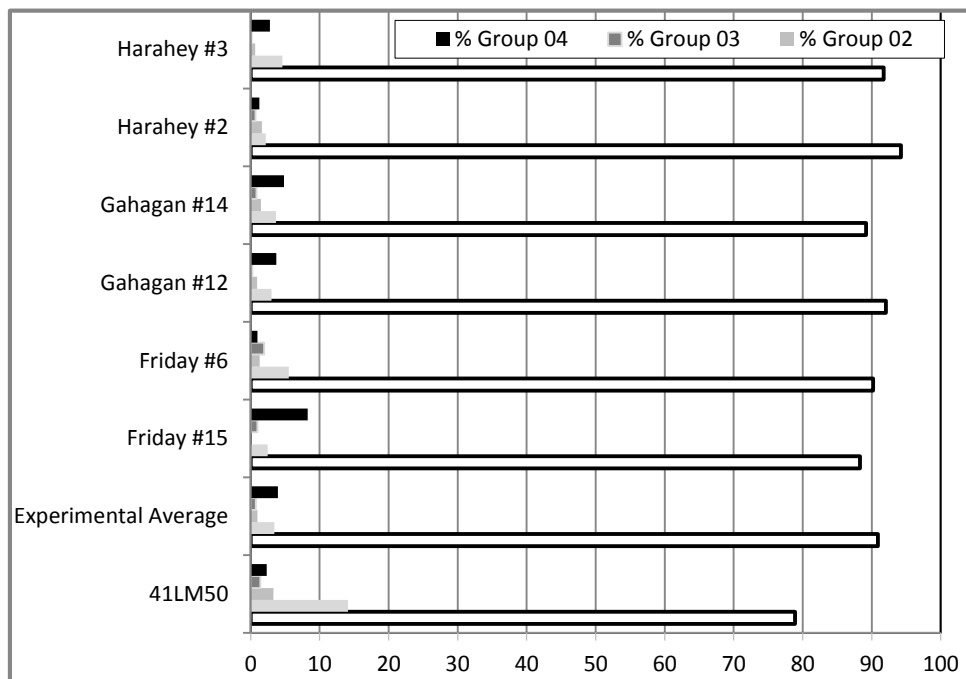
In comparison, debitage recovered from 41LM50 seems to indicate a different distributional pattern. However, the low proportion of  $\frac{1}{4}$  inch and smaller flakes is likely due to collection methodology rather than site occupational patterns. The use of  $\frac{1}{4}$  inch screens for the majority of the screening of sediment for collection purposes perhaps renders the size grade sorting of archeological lithic debitage unfortunately skewed. However, if excludes the potentially skewed  $\frac{1}{4}$  and less Size Grade 04, a pattern of on-site manufacture of lithic tools with small quantities of initial large flakes, increasing quantities of mid-size flakes, and large quantities of smaller flakes is still evident. The similar patterning of the experimental debitage in terms of quantities to size grades provides evidence to support the interpretation of this pattern as one of debris from on-site lithic tool manufacture.

#### ***Dorsal Cortex Percentage***

The experimental debitage was then assessed by percentage of dorsal cortex present. Dorsal cortex groupings in the debitage display a similar correlative pattern for all six replicated bifaces (Table 6-3, Figure 6-10). The greatest proportions of flakes are entirely devoid of cortex on the dorsal surface (i.e., Grouping 00); this group represents between 88 and 94 percent of the debitage in all six cases. Other groupings have relatively minor representations comparatively. Tabular, nodular, or macroflake starting parent raw material do not seem to have a predictable patterned effect upon the resulting cortex groupings, and the results may indicate the thickness of the starting objective pieces are more influential in this category than the



**Figure 6-9. Size grade sorting by percentage for experimental bifaces (both individual and overall average) compared to debitage recovered from 41LM50.**



**Figure 6-10. Dorsal cortex groupings for the six replicated bifaces.** Note: The information in the figure is based on data presented in Table 6-3.



**Table 6-3. Quantities of Cortex Groupings for Debitage from the Production of the Six Replicated Bifaces.**

Type	Experiment	(00) 0%	(01) 1-25%	(02) 26-50%	(03) 51-75%	(04) 76-100%	Total
Harahey	#2	522	12	9	4	7	554
Harahey	#3	556	28	4	1	17	606
Friday	#6	277	17	4	6	3	307
Friday	#15	535	15	0	6	50	606
Gahagan	#12	395	13	4	1	16	429
Gahagan	#14	536	22	9	5	29	601
41LM50	N/A	336	60	14	6	8	426

starting form. Debitage from 41LM50 displays a pattern of cortex grouping that is similar proportionally to what would be expected from on-site manufacture of lithic tools.

Small numbers of extensively cortexed flakes is expected due to the quantitatively constrained amounts of exterior cortex on any starting objective piece, coupled with the possibility of previous off-site initial preparation of the objective starting piece at procurement. Large quantities of flakes without cortex would be expected to coincide with on-site lithic tool manufacture and resharpening/reworking, as these latter stages of preparation (and rejuvenation) produce proportionally far greater flake quantities as the precision of flake removal required increases and therefore the flake size decreases to accompany this care in crafting.

Debitage from the experimental bifaces that retained platforms (whole flakes and proximal flake fragments) totaled 1496 (Figure 6-11). The indeterminate platform category (00) constituted the largest division, ranging between 51 and 74 percent of the total platform-bearing debitage for each specimen. As noted previously, indeterminate platforms were categorized as such because platforms were usually crushed or too minimal (i.e., thin) for clear morphological characteristic identification. As these indeterminate platforms

again indicate an inability to classify a particular platform to a specific category, these platforms will not be discussed further.

Platform-bearing debitage from 41LM50 totaled 350 (excludes missing, indeterminate, or otherwise unclassifiable due to damage from crushing or abrasion). The highest proportion of platforms were present in the multifaceted group ( $N = 203$ ), followed by the single-faceted ( $N = 120$ ). There is only a single complex platform present, and few double ( $N = 11$ ) or cortical platforms ( $N = 15$ ). The significance of these results is unclear. Other characteristics of the debitage seem to indicate on-site manufacture, perhaps with limited initial preparations of objective initial pieces of raw material at procurement locales. However, the low frequency of complex platforms, and the high peaks in frequency of single and multifaceted platforms, without an accompanying peak in double-faceted platforms may indicate that platform assignment is either too subjective to be a reliable interpretive variable or that the presumed progression from cortical to single to double to multifaceted and complex as the lithic tool nears completion is not necessarily correlative and may vary based on knapper preference or technological style or proficiency.

Table 6-4 shows the numerical breakdown of the platform types in the debitage from the six

**Table 6-4. Platform Types for Debitage from the Production of the Six Replicated Bifaces.**

Type	Exp. #	01 Cortical	02 Single	03 Double	04 Multi	06 Complex	Total
Harahey	#2	2	66	23	29	13	133
Harahey	#3	19	63	10	42	13	147
Friday	#6	0	18	5	14	9	46
Friday	#15	12	45	14	22	4	97
Gahagan	#12	49	5	9	13	3	79
Gahagan	#14	54	11	13	18	4	100
41LM50	N/A	15	120	11	203	1	350

replications. Approximately one-half ( $N = 1,607$ ) of the total debitage present ( $N = 3,103$ ) were distal flake fragments on which the proximal, platform-bearing portion was missing (missing platform group 08). This high degree of fragmentation of the debitage is important to keep in mind, however, since the missing platform (08) category indicates a lack of platform rather than a platform type, this category is necessarily excluded from the following discussions of platform types.

The results of the analysis of the bifacial thinning flakes are summarized in Table 6-5 and Figure 6-12. Contrary to initial expectations, the data appears strikingly similar across a majority of the groups. Metric measurements of individual flakes were compiled by experimental replication, and control for variable size of flakes was exacted by calculating L:H ratios. These L:H ratios of individual flakes grouped by experiment specimen were used to run a series of two-sample t-tests to determine if there were any statistically significant differences between the presented values. These statistical tests compared the L:H ratios of individual flakes by specimen to one another (e.g., Test 1: #14 Gahagan [G] to #15 Friday [F]; Test 2: #14 G to #6 F; etc.), as well as L:H ratios across biface types (see Appendix I). All t-tests yielded data that indicate no significant differences with the exception of one pairing: Gahagan #12 and Harahey #3.

Using the two-sample t-test assuming unequal variance [ $t(6) = 2.75$ ,  $p < 0.05$ ] the arc curvature mean of flakes from Specimen #12 Gahagan ( $M = 28.5$ ,  $SD = 1.85$ ,  $N = 3$ ) was significantly different than those of Specimen #3 Harahey ( $M = 18.35$ ,  $SD = 8.67$ ,  $N = 6$ ).

The resulting p-value of 0.03, lower than the significance threshold ( $p < 0.05$ ), provides evidence to reject the null hypothesis of equal means; in other words, this difference has a probability of occurring as a result of chance of less than 5 percent (Table 6-6).

There is no clear explanation for the morphological differences between the bifacial thinning flakes of Gahagan #12 and Harahey #3. The fact that the thinning flakes are flatter on average from Gahagan #12 (27.9) than those measured from Harahey #3 (18.3) is consistent with expected trends. Before Mr. Ringstaff produced these experimental assemblages, he documented the starting material forms (i.e., nodular, tabular, or macroflake). Gahagan #12 was fashioned from a macroflake, a large flake driven off of the parent material form, nodular in this case, which then serves as the objective piece that is reduced (see Table 6-2).

Harahey #3 was made from a tabular piece. The parent material form, that is, whether the initial objective piece was nodular, tabular, or macroflake, certainly has the potential, as a constrictive

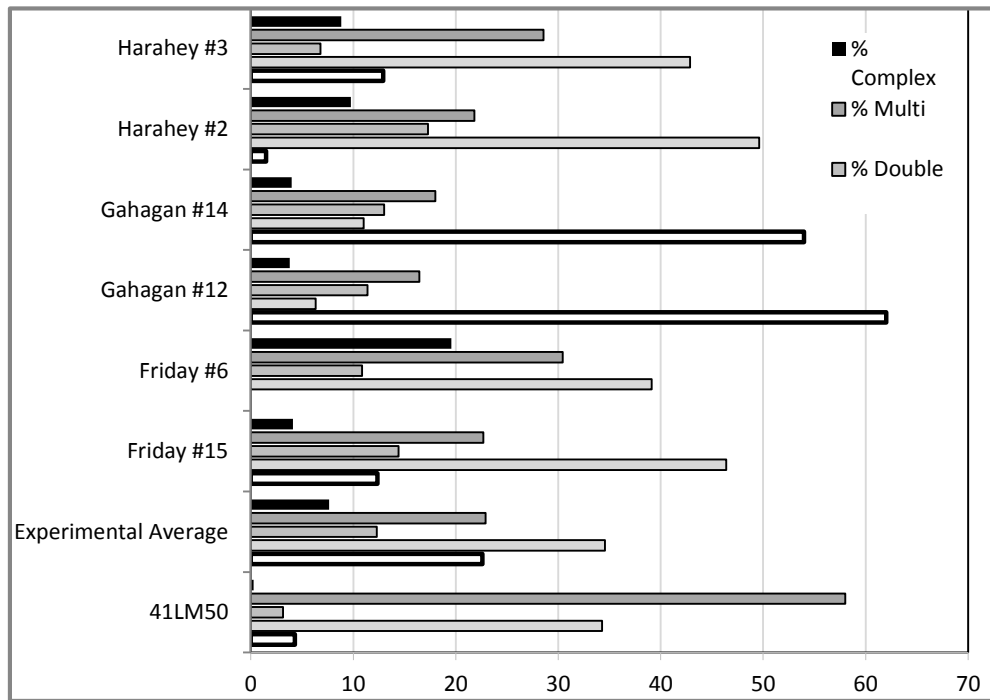


Figure 6-11. Bar graph showing percentages of each platform type present for the six replicated bifaces and their average compared to debitage from 41LM50.

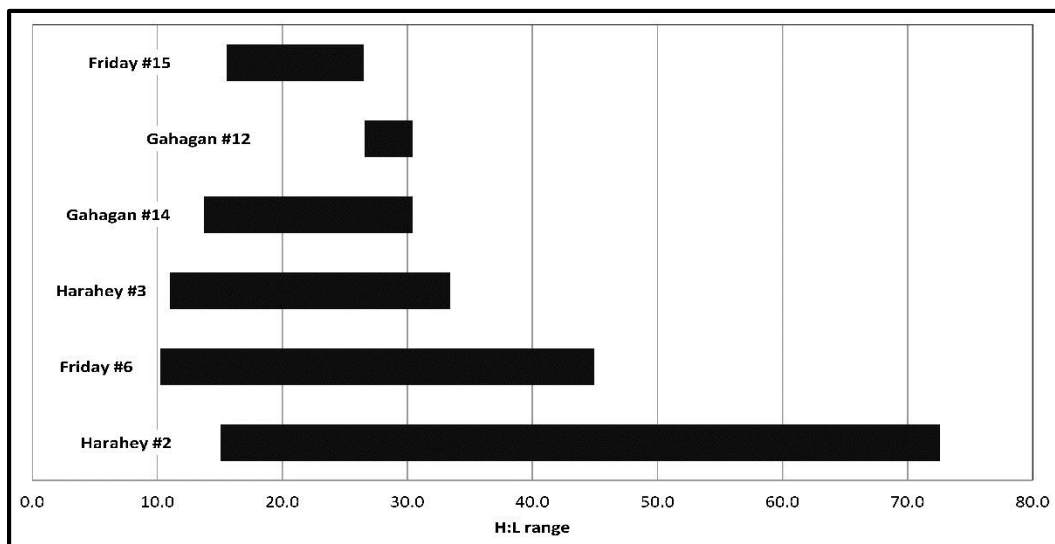


Figure 6-12. Graph showing the range of arc height-to-flake length ratios of bifacial thinning flakes from each of the six replicated bifaces. Note: The highest values indicate the 'flattest' flakes. The Harahey #2 flake with L:H ratio of 110.2 is not charted, as it is an anomalous outlier.

**Table 6-5. Metric Data (in mm) on Whole Bifacial Thinning Flakes from Production of Six Replicated Bifaces.**

Experiment #	Flake Height	Flake Length	L:H Ratio
Harahey #2	2.07	31.12	1:15.0
	1.87	31.20	1:16.7
	0.91	17.02	1:18.7
	1.02	24.26	1:23.8
	0.96	26.34	1:27.4
	1.14	39.11	1:34.3
	1.03	36.09	1:35.0
	0.37	26.86	1:72.6
	0.21	23.15	*1:110.2
<b>Harahey #2 Average</b>	<b>1.06</b>	<b>28.35</b>	<b>1:39.3</b>
Harahey #3	1.69	18.60	1:11.0
	2.45	31.73	1:13.0
	1.59	21.93	1:13.8
	1.71	25.52	1:14.9
	1.54	36.80	1:23.9
	1.52	50.85	1:33.5
<b>Harahey #3 Average</b>	<b>1.75</b>	<b>30.91</b>	<b>1:18.3</b>
<b>Harahey Type Average</b>	<b>1.34</b>	<b>29.37</b>	<b>1:30.9</b>
Friday #6	1.53	15.71	1:10.3
	2.51	26.49	1:10.6
	1.48	20.00	1:13.5
	3.54	60.21	1:17.0
	1.14	33.36	1:29.3
	0.90	34.08	1:37.9
	0.55	24.71	1:44.9
<b>Friday #6 Average</b>	<b>1.66</b>	<b>30.65</b>	<b>1:23.3</b>
Friday #15	1.55	24.15	1:15.6
	1.04	18.14	1:17.4
	2.01	53.31	1:26.5
<b>Friday #15 Average</b>	<b>1.53</b>	<b>31.87</b>	<b>1:19.8</b>
<b>Friday Type Average</b>	<b>1.63</b>	<b>31.02</b>	<b>1:22.3</b>
Gahagan #12	1.77	47.08	1:26.6
	1.61	42.99	1:26.7
	0.93	28.27	1:30.4
<b>Gahagan #12 Average</b>	<b>1.44</b>	<b>39.45</b>	<b>1:27.9</b>
Experiment #	Flake Height	Flake Length	L:H Ratio
Gahagan #14	2.33	32.05	1:13.8
	0.96	25.00	1:26.0
	0.93	28.27	1:30.4
<b>Gahagan #14 Average</b>	<b>1.41</b>	<b>28.44</b>	<b>1:23.4</b>
<b>Gahagan Type Average</b>	<b>1.42</b>	<b>33.94</b>	<b>1:25.6</b>

\*anomalous outlier

**Table 6-6. T-Test Results for Comparison of Experimental Specimens Gahagan #12 and Harahey #3.**

<b>t-Test: Two-Sample Assuming Unequal Variances</b>		
	<b>#12 Gahagan</b>	<b>#3 Harahey</b>
Mean	28.5	18.35
Variance	3.43	75.115
Standard Deviation	1.852025918	8.666891023
Observations	3	6
Hypothesized Mean Difference	0	
df	6	
t Stat	2.746002667	
P(T<=t) two-tail	<b>*0.0334684449908384</b>	
t Critical two-tail	2.446911846	
<i>* Significant : p-value less than 0.05, Confidence 95%</i>		

variable, to influence the resulting morphology of a biface and flakes derived from it.

However, this apparent potential difference in curvature by parent material form of these two specimens is not evidenced in any of the other specimens with regard to parent material form.

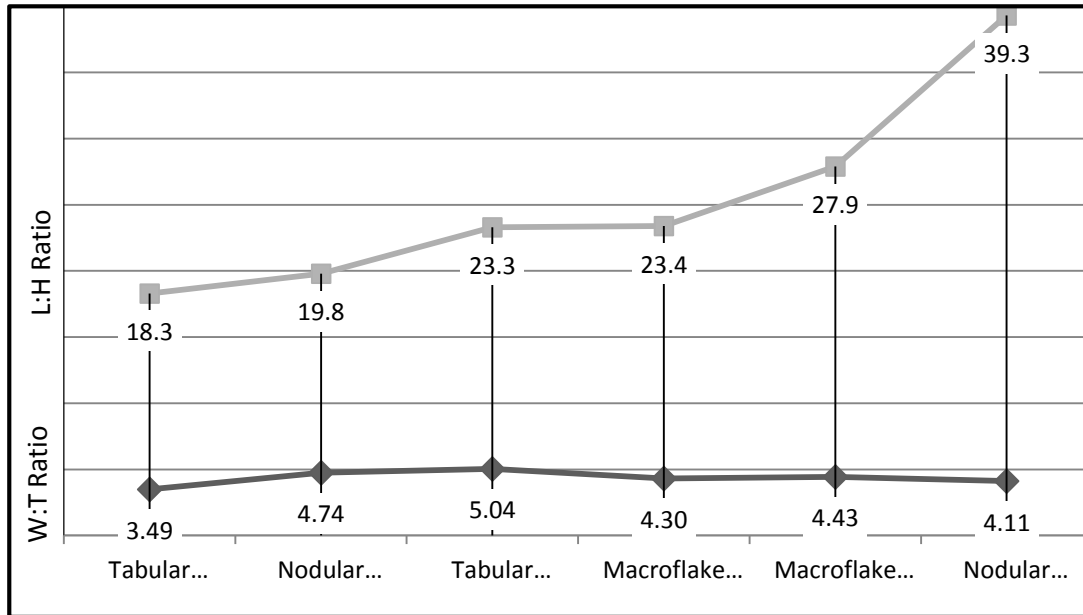
For instance, Friday #6 is also from tabular parent form, but the average L:H ratio of this specimen is 23.3, nearly the same as that from Gahagan #14 (23.4), derived from a nodular macroflake. Therefore, we must attribute the statistically significant differences between these two specimens to an unknown variable and treat it as an outlier.

Harahey #3 also exhibits the smallest ratio (18.3) and therefore the greatest curvature of the flakes by specimen. Interestingly enough, the greatest ratio (39.3), and therefore the least curvature and ‘flattest’ flakes by specimen, is from Harahey #2, the other specimen in the Harahey group Figure 6-13).

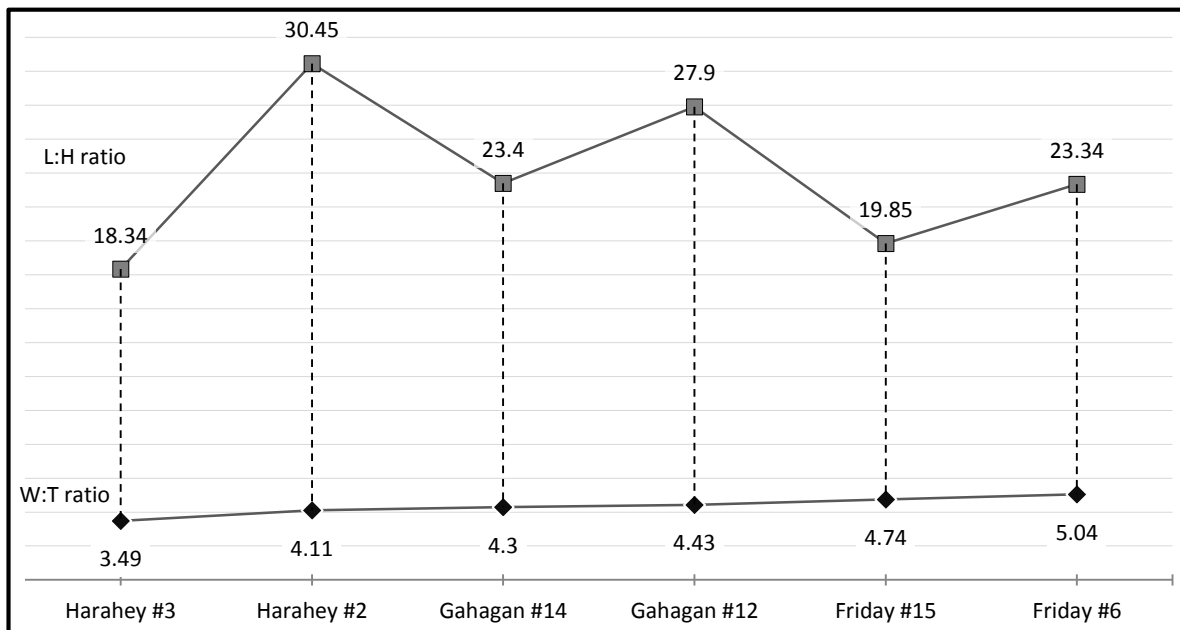
In fact, the Harahey bifaces have the flattest overall average flakes (30.9) when compared by type (see Table 6-5). Therefore, the flakes that exhibit both the greatest and the least curvature both come from production of the same biface type.

The bracketing by the Harahey bifaces on both the high and low ends of the arc curvature results on the replicated debitage suggested that perhaps the production of these four-beveled forms was potentially significantly different in some unknown way from that of the other forms, therefore, potentially skewing the results. However, neither replication study data nor data from curated archeological specimens supports this assumption. When Haraheys are removed from consideration, Gahagans still do not exhibit statistically significant patterned differences from Fridays in neither analysis of replicated debitage, nor of curated archeological specimens (see Table 6-6 and Table 6-7).

Overall, the findings indicate no statistically significant differences between curvatures (flake length-to-arc height ratios) of flakes when compared by biface type, and only one significant difference when compared by individual specimens (Figure 6-14). As a group, bifacial thinning flake L:H ratios from Gahagan replications (25.6) are not significantly flatter statistically (i.e., they do not have a greater flake length-to-arc height ratio) than the thinning flakes resulting from the production of either Friday bifaces (22.3) or Harahey knives (30.9).



**Figure 6-13. Relative flake flatness (L:H ratios) of bifacial thinning flakes.** Note: This figure is from each of the six replicated bifaces from most curved on the left to the least curved on the right, compared to relative thickness of finished bifaces (W:T ratios). Higher L:H values indicate 'flatter' flake averages. Also, note the lack of correlation of flat flakes to thin bifaces. Harahey #3, the thinnest biface, actually has the most curved flakes, with a L:H ratio of 18.3.



**Figure 6-14. Graph showing the lack of correlation between biface W:T ratios (relative finished biface thickness) and average of flake L:H ratios (relative flatness of associated bifacial thinning flakes) for experimental replicated bifaces.** Note: The bifaces are sorted by relative thickness from left to right; thinnest Harahey #3 to thickest Friday #6.

From this limited replication study, it appears that neither parent material form nor the production of different biface types results in predictably patterned debitage that could be recognized in archeological contexts.

The reasons for these unexpected outcomes are not entirely clear. Since only whole flakes (with complete measurable lengths) could be used in this analysis, it is possible that a significant underrepresentation of longer flakes (and corresponding greatest height-to-length ratios) results from the tendency for longer flakes to break more easily.

This hypothesis is untestable within the framework of archeological and replication analysis, and is a question that could only be answered within the field of materials science (i.e., the study of the effects of stress on particular types of materials). Such long, thin flakes have an inherent fragility. Approximately 33 percent of the biface thinning flakes present in the experimental debitage were fragmentary. Bifacial thinning flakes, as defined by the TxDOT Lithic Protocol (2010), have complex platforms, and only 46 flakes total were present in the debitage that fit this criteria. Of those, only 31 were whole thinning flakes. Presumably, the fragmentary specimens were broken either during the initial flake removal process or through indeterminate stresses of unknown agency at a later point in time.

Therefore, the quantity of whole thinning flakes ( $N = 31$ ) available for this study may simply be too limited to obtain reliable comparisons between a likewise very limited set of six variables (i.e., the six replicated bifaces).

## 6.4 CONCLUSIONS

When the essential metrics behind the study, the finished biface width compared to the thickness, were compared as independent variables for the archeological specimens sampled (Figure 6-15), a

great deal of distributional grouping, overlap of the three biface types was apparent. Initially, discernible patterned differences were apparent in this ratio between the three types. In order to assess if these perceived patterns of distribution by type of the archeological samples were statistically relevant, statistical analysis was performed to access both intra-type and inter-type variability through form consistency and correlation between variables of width and thickness. In order to account for the potential skew outliers may introduce, especially in a small sample, results were also calculated incorporating a 5 percent trimmed sample.

### *Archeological Gahagans*

Contrary to expectations, the Gahagans proved the thickest of the archeological sampled types, with an average W:T of 5.71, SD 1.51 (trimmed: W:T 5.58, SD 1.05). Gahagan W:T ratios range from 3.61 to 9.03. Most variable in both width (23.61 CV) and thickness (21.14 CV) of the three biface types

### *Archeological Haraheys*

Harahey knives are the thinnest sampled type, with an average 3.74 W:T ratio (0.85 SD). Least variable of the types in both width (18.84 CV) and thickness (15.84 CV), Harahey bifaces likewise displayed the most restrictive variation of W:T ratio (22.83 CV), indicating that the patterning of these distinctive bifaces came closest of the types to a direct correlative between width and thickness. Haraheys average a T:W ratio of 0.281:1, with a range of 0.190:1 to 0.422:1 (0.07 SD, 24.08 CV).

### *Discussion*

Biface relative thickness, calculated with the W:T ratio, bears little correlation to the metric measurement of maximum thickness as an independent variable (see Figure 6-15). Potentially a larger sample size could reveal a more distinguishable or definable broad overall pattern, which the current sample cannot. However, it is prudent to consider that the null hypothesis is types.

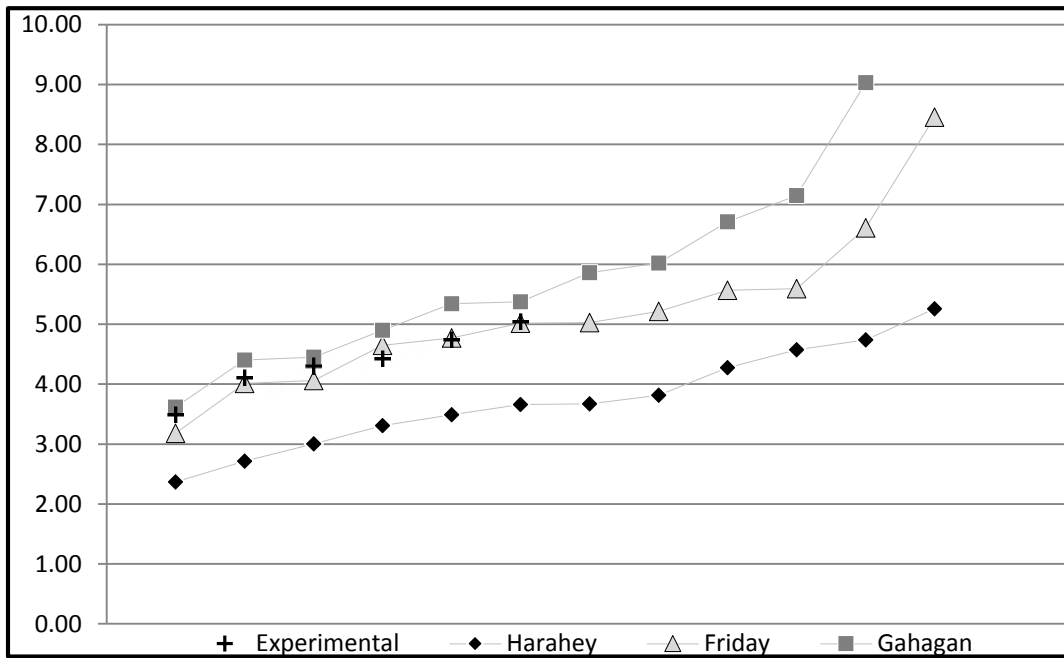


Figure 6-15. Comparative plot of biface W:T ratio ranges of archeological samples sorted by biface typologies (trendlines and experimental bifaces are included for comparative purposes).

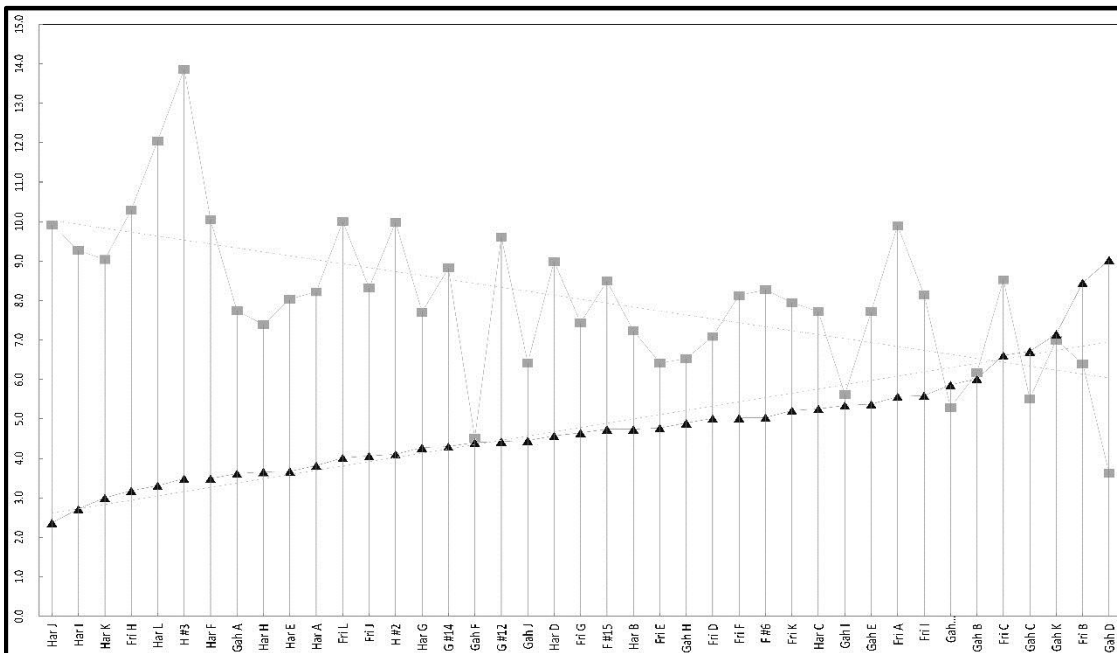


Figure 6-16. Plot of relative biface thickness compared to maximum biface thickness variable. Note: The relative thicknesses of bifaces, expressed as biface W:T ratios (triangles), are ordered from thinnest/flattest to thickest, and compared to the associated biface maximum thickness (squares). The lack of correlative patterning between maximum thickness of a biface, as an independent variable, with relative thickness is evident. When W:T ratios of all biface types are ordered from smallest to largest, the lack of correlative patterning by biface typology is also apparent. (Biface types are abbreviated. Letters correspond to archeological specimens, numbers to experimental replication bifaces.)



**Table 6-7. Results of T-tests for W:T of Archeological Biface Samples by Types (t-tests are two-tailed, two-sample, assuming unequal variances).**

t-Test: Two-Sample Assuming Unequal Variances			
	<i>Gahagan W:T</i>	<i>Friday W:T</i>	
Mean	5.714213157	5.179072722	
Variance	2.280924886	1.83482403	
Standard deviation	1.510273117	1.354556765	
Observations	11	12	
Hypothesized mean difference	0		
df	20		
t Stat	0.891580296		
P(T<=t) one-tail	0.191609627		
t Critical one-tail	1.724718218		
P(T<=t) two-tail	0.383219254		<b>Not Significant</b>
t Critical two-tail	2.085963441		
t-Test: Two-Sample Assuming Unequal Variances			
	<i>Gahagan W:T</i>	<i>Harahey W:T</i>	
Mean	5.714213157	3.739679358	
Variance	2.280924886	0.728997666	
Standard deviation	1.510273117	0.853813602	
Observations	11	12	
Hypothesized mean difference	0		
df	16		
t Stat	3.81338636		
P(T<=t) one-tail	0.00076447		
t Critical one-tail	1.745883669		
P(T<=t) two-tail	0.001528939		<b>Significant</b>
<b>t Critical two-tail</b>	<b>2.119905285</b>		<b>p-value less than 0.05</b>
			<b>Confidence 95%</b>
t-Test: Two-Sample Assuming Unequal Variances			
	<i>Friday W:T</i>	<i>Harahey W:T</i>	
Mean	5.179072722	3.739679358	
Variance	1.83482403	0.728997666	
Standard deviation	1.354556765	0.853813602	
Observations	12	12	
Hypothesized mean difference	0		
df	19		
t Stat	3.114054507		
P(T<=t) one-tail	0.002856617		
t Critical one-tail	1.729132792		
P(T<=t) two-tail	0.005713234		<b>Significant</b>
<b>t Critical two-tail</b>	<b>2.09302405</b>		<b>p-value less than 0.05</b>
			<b>Confidence 95%</b>
t-Test: Two-Sample Assuming Unequal Variances			
	<i>Gahagan W:T</i>	<i>Friday W:T</i>	
Mean	5.714213157	5.179072722	
Variance	2.280924886	1.83482403	
Standard deviation	1.510273117	1.354556765	
Observations	11	12	
Hypothesized mean difference	0		
df	20		
t Stat	0.891580296		

P(T<=t) one-tail	0.191609627		
t Critical one-tail	1.724718218		
P(T<=t) two-tail	0.383219254		<b>Not Significant</b>
t Critical two-tail	2.085963441		
<b>t-Test: Two-Sample Assuming Unequal Variances</b>			
	<b><i>Gahagan W:T</i></b>	<b><i>Harahey W:T</i></b>	
Mean	5.714213157	3.739679358	
Variance	2.280924886	0.728997666	
Standard deviation	1.510273117	0.853813602	
Observations	11	12	
Hypothesized mean difference	0		
df	16		
t Stat	3.81338636		
P(T<=t) one-tail	0.00076447		
t Critical one-tail	1.745883669		
P(T<=t) two-tail	0.001528939		<b>Significant</b>
<b>t Critical two-tail</b>	<b>2.119905285</b>		<b>p-value less than 0.05</b>
			<b>Confidence 95%</b>
<b>t-Test: Two-Sample Assuming Unequal Variances</b>			
	<b><i>Friday W:T</i></b>	<b><i>Harahey W:T</i></b>	
Mean	5.179072722	3.739679358	
Variance	1.83482403	0.728997666	
Standard deviation	1.354556765	0.853813602	
Observations	12	12	
Hypothesized mean difference	0		
df	19		
t Stat	3.114054507		
P(T<=t) one-tail	0.002856617		
t Critical one-tail	1.729132792		
P(T<=t) two-tail	0.005713234		<b>Significant</b>
<b>t Critical two-tail</b>	<b>2.09302405</b>		<b>p-value less than 0.05</b>
			<b>Confidence 95%</b>

applicable perhaps beyond this limited study, and potentially the three biface types of Gahagan, Friday, and Harahey are simply too close in these particular characteristics of width compared to thickness to distinguish between the

This could also indicate that if the three biface finished forms are indistinguishable statistically metrically, the production techniques and resulting debitage may also be indistinguishable behaviorally and technologically, and therefore, statistically and archeologically

## 6.5 SUMMARY

We started this study with the assumption that Gahagans are relatively thinner biface types than Haraheys and Fridays, and therefore perhaps would have flatter flakes produced in the late manufacturing stages, potentially allowing the development of a model wherein bifacial thinning flake curvature could be utilized as an indicator of what biface type had been manufactured.

Although Shafer (2006) suggested that thin Gahagans might produce potentially distinguishable archeologically flatter flakes, he

also cautioned that Fridays and Gahagans may not actually be distinguishable. The analysis of the experimental and archeological data indicates that Shafer's caution was well-founded.

The analytical results indicate that it may not be possible to correlate bifacial thinning flake curvature with the production of certain biface typologies (Gahagan, Friday, or Harahey). Results suggest that even correlation of flat bifacial thinning flakes to the production of flat, thin bifaces is not possible. There was no correlation of the experimental replications between the thinness of the finished biface (W:T ratio) and the flatness of the bifacial thinning flakes (L:H ratio) associated with the production of that biface (see Figure 6-16).

Moreover, the data indicates that in fact, even the basic assumption that Gahagans were thinner bifaces than Fridays and Haraheys was incorrect. Although the average Gahagan maximum thickness is lower than that of the other types when looked at as a discrete and independent variable, it cannot be considered alone. Thickness and width are interdependent variables that cannot be considered separate from each other. The W:T ratio takes into account the interdependency of the two variables of width and thickness to get the *relative thickness* of the biface. Gahagans are not the thinnest bifaces *relatively*. Their W:T ratio ranges overlapped both Friday and Harahey bifaces. In fact, over 80 percent of the range of W:T archeological sample of Gahagans overlapped that of the Fridays, and the point of discrete variability only occurred on the thicker side of the range, making them statistically *thicker* than Fridays, not thinner.

Sampled archeological Gahagan bifaces were not distinguishable statistically in terms of relative thickness from Fridays and Haraheys. Gahagans were the most variable of the biface types in terms of width and thickness, both as independent and interdependent variables, with the least correlation between variables and the widest quantitative range spread of relative thickness ratios. Gahagans were

not, in fact, relatively thinner bifaces than Haraheys and Fridays, but statistically the *thickest* of all the sampled types. Of the archeological samples, the Haraheys were the thinnest sampled type, and proved the most conservative in thickness, with the least variation in thickness comparative to width differences.

Typology did not appear as a constraining factor upon width and thickness. Relative thickness overlapped significantly among all three typologies. It appears that the form of the raw parent material, that is, tabular, nodular, or macroflake, is perhaps a significant constrictive factor upon these variables. However, the knapper can adjust for these restrictions, as archeological specimens indicate through significant variability in absolute width and thickness, but little variability overall in relative width-to-thickness. That is, although maximum thickness may vary significantly, the corresponding width was scaled to match, resulting in little variation in W:T ratio. Impressively low covariance in terms of width-to-thickness and typology among the experimental bifaces indicated that perhaps the knapper is the key factor overlooked in these lithic studies. The study data provides an intriguing suggestion that perhaps the *knapper* is the most significant and most constraining factor in terms of biface morphology. It would be interesting to see if a larger archeological and experimental study (with additional samples to compare amongst different knappers) would perhaps lead to development of a model wherein archeological biface morphological characteristics could potentially reveal patterns of limited intra-site manufacture by knappers sharing the same technological style (perhaps a family group) versus larger inter-site patterns of trade or tool curation.

Therefore, on the basis of these findings, it must be concluded that analysis of the archeological debitage recovered from 41LM50 cannot be expected to reveal whether or not Gahagan bifaces

were manufactured at that site. The analyses on the debitage from the six experimental bifaces do not reveal any patterned differences or contrasts in the debitage from the three biface types (Gahagan, Friday, or Harahey) such as would provide a reliable means for addressing this question using the archeologically recovered debitage assemblages.

The inconclusive results cannot contribute to the identification of the specific kind(s) of relatively large, thin bifaces that may have been produced at 41LM50. Thus, in accord with the stipulations presented in the research design, the question of the presence/absence of on-site Gahagan biface

production, and potential implications linking the Late Prehistoric component to the Southern Prairie Caddo pattern hypothesized by Shafer (2006), cannot be investigated. Therefore, such considerations must be excluded from our further analysis of the artifact assemblage from this site. Indeed, based on the present findings, it appears likely that identification of what Shafer (2006) termed the Prairie Caddo in central Texas must continue to be predicated upon the presence of diagnostic artifacts such as Caddo or Caddo-like ceramics, finished lithic tool types (e.g., Gahagan bifaces, Alba-Bonham arrow points), and perhaps certain bone artifact traits (i.e., needles, deer metapodial beamers) listed in his 2006 monograph.

*This page intentionally left blank.*

## **7.0 GEOARCHEOLOGICAL EVALUATION**

Charles D. Frederick

### **7.1 INTRODUCTION**

This report describes the geologic setting of three archeological sites located northwest of Lampasas along targeted roadway at two separate crossings of Lynch Creek, a tributary of the Colorado River. At the easternmost crossing of Lynch Creek two archeological sites are present, 41LM49 and 41LM50. Site 41LM49 is located on the right bank or south bank of the stream, whereas 41LM50 is situated immediately across the creek and west of the highway. The third site, 41LM51 is located about a 1.6 km (1 mile) west of the first crossing where Lynch Creek flows from north to south under the east to west highway. Site 41LM51 is located on the left bank or east bank of the creek on and within the floodplain and higher terrace deposits.

### **7.2 METHODS**

Mechanical trenches were excavated within the existing and proposed highway right-of-way. In most cases these exposures were fairly discrete 4 to 6 m long excavations. However, a couple of trenches were long, extensive excavations that were made in order to reveal an extensive cultural feature (like the burned rock midden at 41LM49) or where major bounding surfaces between one or more units were anticipated (as in Trench 1 at 41LM51). Trench excavations were also intended to provide platforms for hand-excavated test units of prehistoric occupation surfaces identified in the deposits. Profiles were described in the field and descriptions generally follow Schoeneberger et al. (2002; see Appendix A). Schematic illustrations of the stratigraphy at the two stream crossings are provided on Figure 7-1.

### **7.3 ALLUVIAL STRATIGRAPHY**

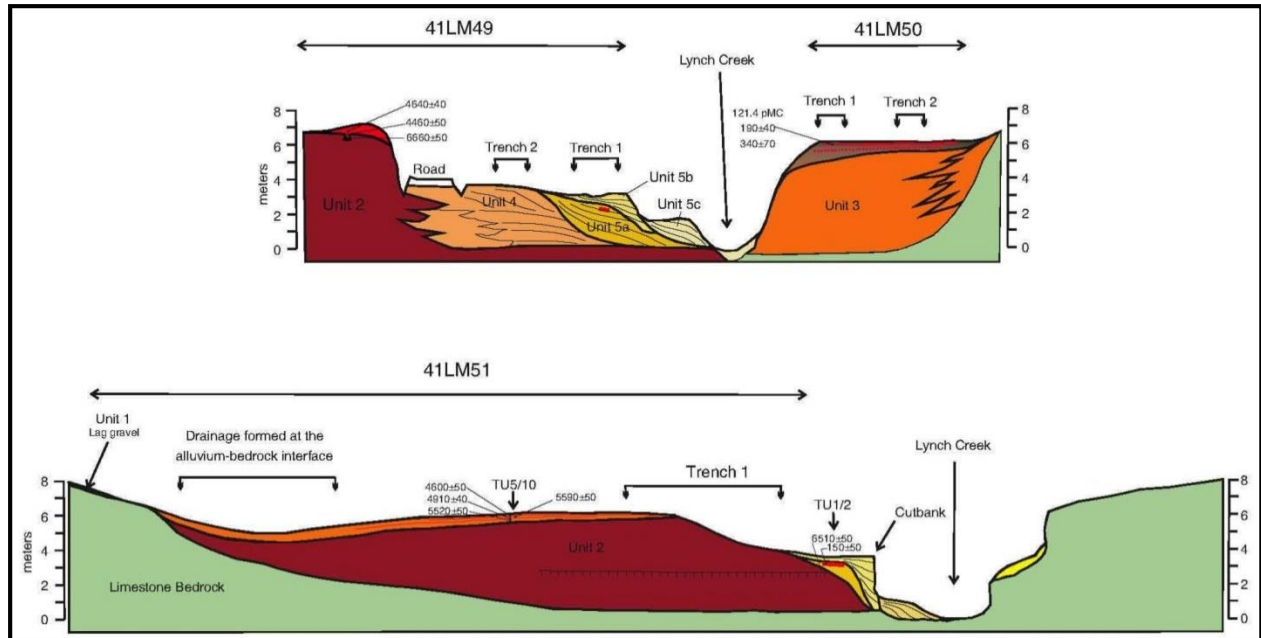
Although the work described in this report occurred at two separate crossings of Lynch Creek, the geomorphological and stratigraphic observations are combined here to avoid repetition later and to provide a more comprehensive picture of the geology in the area.

There are at least three distinct constructional geomorphic surfaces present in the Lynch Creek valley: the modern floodplain ( $T_0$ ), a low terrace ( $T_1$ ), and a high terrace ( $T_2$ ). The modern floodplain rises about 3 m above the thalweg and consists of a flat to gently rolling surface with prominent sand and gravel bars inset against it, and flanks the modern channel. Where it is well expressed, this surface is marred by many shallow linear scour features. In places, the floodplain is inset into the low terrace, which rises to an estimated elevation of about 4 m above the existing channel. Elsewhere the  $T_0$  surface is formed on and adjacent to strath surfaces cut into older alluvial deposits. The  $T_1$  or low terrace forms a slightly higher, relatively flat surface adjacent to the modern floodplain, and is probably still inundated by extreme flood events. The  $T_2$  surface rises to an elevation of roughly 6 to 7 m above the channel and has a prominent flat to gently sloping surface.

#### **7.3.1 Late Quaternary Alluvial Deposits**

##### **7.3.1.1 Unit 1**

The oldest alluvial deposit observed along Lynch Creek is lag gravel exposed along the east side of the stream valley at 41LM51. This deposit lies scattered across the sloping bedrock surface upslope of Unit 2 and comprises a thin scatter of siliceous rocks (primarily chert and quartzite; see Figure 7-2). North of the highway, this deposit appears significantly thicker (possibly approaching 1 m), but no good vertical exposures were observed. The height, nature of preservation, and lithology of this deposit indicates it is in excess of 20,000 years old. The lithology implies that it may be an ancient



**Figure 7-1. Alluvial stratigraphy and cultural strata at 41LM49, 41LM50, and 41LM51.** Note: The top panel illustrates the stratigraphic relationships observed at 41LM49 and 41LM50. The bottom panel shows the stratigraphic relationships observed at 41LM51. In both cases, the stratigraphic units shown are described in detail in the text.

Colorado River deposit, or a Lynch Creek deposit derived from the same. Prehistoric populations clearly used this gravel lag as a lithic procurement source.

### 7.3.1.2 Unit 2

Unit 2 is found beneath the T2 surface and consists of more than 6 m of brown to light brown sandy alluvium within which an A-AB-Bk-Ck-C soil profile has formed. A prominent Stage II calcic horizon has formed in these sandy sediments, and the presence of a faint, incipient soil in the core of this deposit suggests deposition was episodic. Almost no gravel or mud was observed within this deposit suggesting it was formed under less flashy discharge regime than prevails today. Unit 2 was revealed by Trench 1 at 41LM51 and is presumed present beneath the burned rock middens on the T2 surface at 41LM49

### 7.3.1.3 Unit 3

This unit consists of more than 6 m of relatively fine-grained clayey alluvium situated beneath the T<sub>2</sub> surface and was observed only at 41LM50. It is possible that this deposit is a fine-grained facies of Unit 2, but for the time being it is tentatively interpreted as a fine-grained early Holocene alluvial deposit. Two bulk sediment samples were collected from the Bk horizon in Trench 1 at 41LM50 to check this interpretation, but they were not submitted for dating.

The soil formed in this unit exhibited an A-Bk-C profile, with a Stage II or nodular calcic horizon. A cumulic A horizon marks the top of the deposit, and this cumulic zone forms a wedge that appears to thicken toward the center of the valley. At least two occupation surfaces are preserved within this cumulic soil, an early Late Prehistoric one, at a depth of around 60 to 70 cm, and a Late Prehistoric one, very shallowly buried beneath the surface.



**Figure 7-2. Photograph of the Unit 1 gravel lag on a limestone bedrock surface upslope of Unit 2, east of 41LM5.** (Photograph by C. Frederick).

### 7.3.1.5 Unit 5

This deposit consists of at least three or more phases of lateral and vertical accretion separated by brief periods of scour. The oldest of these phases is a deposit of alternating pale brown gravelly sediment and brown to dark brown loamy sediment with prominent lateral accretion sets

Within this deposit several incipient soils exhibit A-C profiles. This deposit, designated Unit 5a, contains Late Prehistoric occupations, one of which came from the top of the fill in TU 2 at 41LM51 and yielded a radiocarbon age of  $130 \pm 50$  years B.P. (UGA-14421) at a depth of 23 cmbs and a date of  $290 \pm 30$  years B.P. (Beta-345278) at a depth of 30 to 40 cmbs in association with a Toyah component. Another, presumably Late Prehistoric feature was observed within this stratigraphic unit in Zone 20 of Trench 1 at 41LM49 (see Figures 7-3 and 7-4), but it was not radiocarbon dated.

In most places, Unit 5a appears buried by lateral and/or vertical accretion sets of Unit 5b. This deposit consists of alternating brown and light brown beds of sand, loam and silty loam. The majority of those examined in the field appear to have formed by vertical accretion (e.g., 41LM51

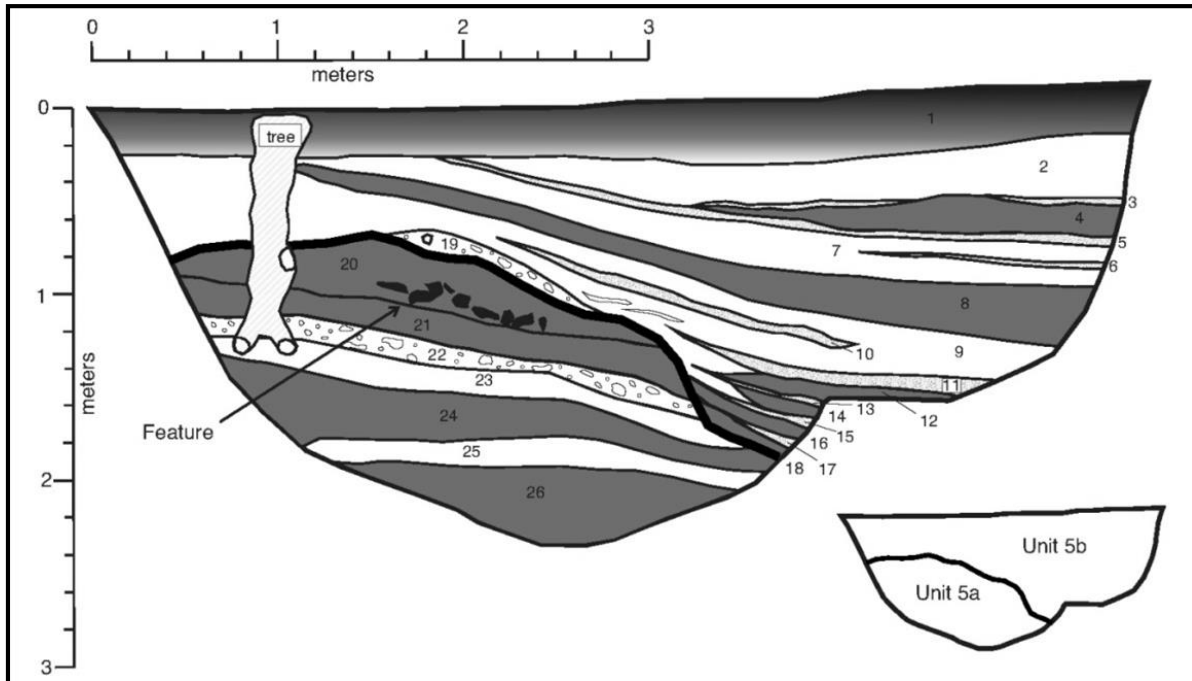
cutbank; north side of Trench 1 at 41LM49). Where cultural material was observed within this unit, it was of historic age and contained of glass or plastic.

The most recent phase of deposition (Unit 5c) is represented by prominent sand and gravel bars that occur at the foot of the  $T_0$  surface (and below exposures of Unit 5b), essentially at the outer edge of the modern channel. These bars were not examined in detail in the field but are clearly of modern age. Although Unit 5 deposition continues today, the antiquity of this unit is unknown, but it is anticipated to be correlative with Blum's modern fill at Stacy Reservoir (present day O. H. Ivie Reservoir; Blum and Valastro 1992) and represent roughly the last 1,300 years.

## 7.4 STRATIGRAPHIC SUMMARY

Although the units described here were not comprehensively dated, the age and alluvial architecture seems to most closely resemble the deposits of the Colorado River (Blum and Valastro 1992; Blum et al. 1994). If the inference that Unit 3 is a Holocene deposit is correct, then there is a significant difference in alluvial architecture between Lynch Creek and the Colorado River, with early to middle Holocene deposits graded to a different level than the middle to late Holocene deposits. However, if the core of Unit 2 is of Pleistocene age, then architecture of this alluvial sequence may more closely resemble the deposits of the Lampasas River described by Pearl (1997). In addition to an undated high Pleistocene terrace, Pearl documented fine-grained alluvial deposits dating to the middle to late Holocene: Unit II deposited between ca. 5100 to 1100 years B.P.; and three post 1000 years B.P. deposits: Unit III that was radiocarbon dated to ca. 1100 to 900 years B.P. and capped by a named paleosol (the Lovelady paleosol), Unit IV that was deposited between ca. 900 and 500 years B.P.; and Unit V that is essentially modern. Conspicuously absent in this





**Figure 7-3.** Drawing of the southwestern wall of Trench 1, 41LM49, showing lateral accretion sets of Unit 5a, and primarily vertical accretion deposits of Unit 5b. Note: this trench exposed Units 5a and 5b, which are separated by a heavy line and illustrated in the smaller outline at the bottom right hand side of Figure 4. Note the prehistoric burned rock Feature 2 in Zone 20, and truncation of this surface by the erosional surface between Unit 5a and 5b.



**Figure 7-4.** Photograph of southwestern wall of Trench 1, 41LM49, showing lateral accretion sets of Unit 5a, and primarily vertical accretion deposits of Unit 5b.

sequence is any fine-grained alluvial deposition in the late Pleistocene to middle Holocene period.

## **7.5 GEOARCHEOLOGICAL SUMMARY**

At least five different age alluvial deposits appear present at the three prehistoric sites along this roadway at two separate crossings of Lynch Creek. The tread of the highest surface, T<sub>2</sub> appears to have been repeatedly occupied throughout the Holocene, but especially in the late Early to Middle Archaic. At 41LM49, cultural deposits on this surface are thought to have little research potential. At 41LM51, apparent alluvial sedimentation on the tread of this T<sub>2</sub> Pleistocene terrace during a 1,000

year period in the middle Holocene appears to have buried a series of Archaic occupation surfaces. At 41LM50, Late Prehistoric occupations were discovered shallowly buried beneath the tread of what is inferred a clayey early Holocene alluvial deposit with a thick cumulic A horizon. Late Prehistoric occupation of the modern floodplain during the last 1,000 years was noted at both 41LM49 and 41LM51. Trench 1 at 41LM49 scour associated with lateral accretion appears to have adversely affected the preservation of this occupation. At 41LM51, the Late Prehistoric occupation appears buried by vertical accretion deposits; therefore, it has a greater potential for preservation.

*This page intentionally left blank.*

## 8.0 TESTING RESULTS AT 41LM49

J. Michael Quigg and Charles D. Frederick

### 8.1 INTRODUCTION

This chapter presents the results of archeological evaluation and testing investigations within the existing FM 580W right-of-way at prehistoric site 41LM49. This was a previously unrecorded site east of Lynch Creek Bridge and adjacent to the creek and roadway. Construction of FM 580W removed most the T<sub>2</sub> terrace deposits from within the northern side of the current right-of-way, which left a steep sloping artificial edge of that terrace along the right-of-way fence line. Most of 41LM49 extends northward across private property (Figure 8-1). No new right-of-way or easement was planned on this eastern side of Lynch Creek. Therefore, the archeological assessment was mostly directed towards the very northern margin of the current right-of-way, along and below the fence line at the exposed burned rocks in the sloping deposits of the T<sub>2</sub> terrace.

The core of site 41LM49 consists of a series of at least three large, low dome-shaped burned rock mounds (designated BRMs 1 through 3), which are north of the existing right-of-way and within 65 m of the bridge. The three mounds measured roughly 10 to 15 m in diameter and 0.5 to 1.0 m tall. All three mounds appeared disturbed by relic collectors. BRM 1 was partially exposed immediately under the current northern right-of-way fence in the steeply sloping, artificial edge of the T<sub>2</sub> terrace, on the eastern edge of the project area. BRM 2 is about 5 m further north of the fence, whereas BRM 3 is estimated to be 25 m northward from the fence at the edge of Lynch Creek.

The burned rock mounds are situated on the higher T<sub>2</sub> surface that overlooks a relatively broad expanse of the T<sub>1</sub> to T<sub>0</sub> surfaces to the southwest, the active

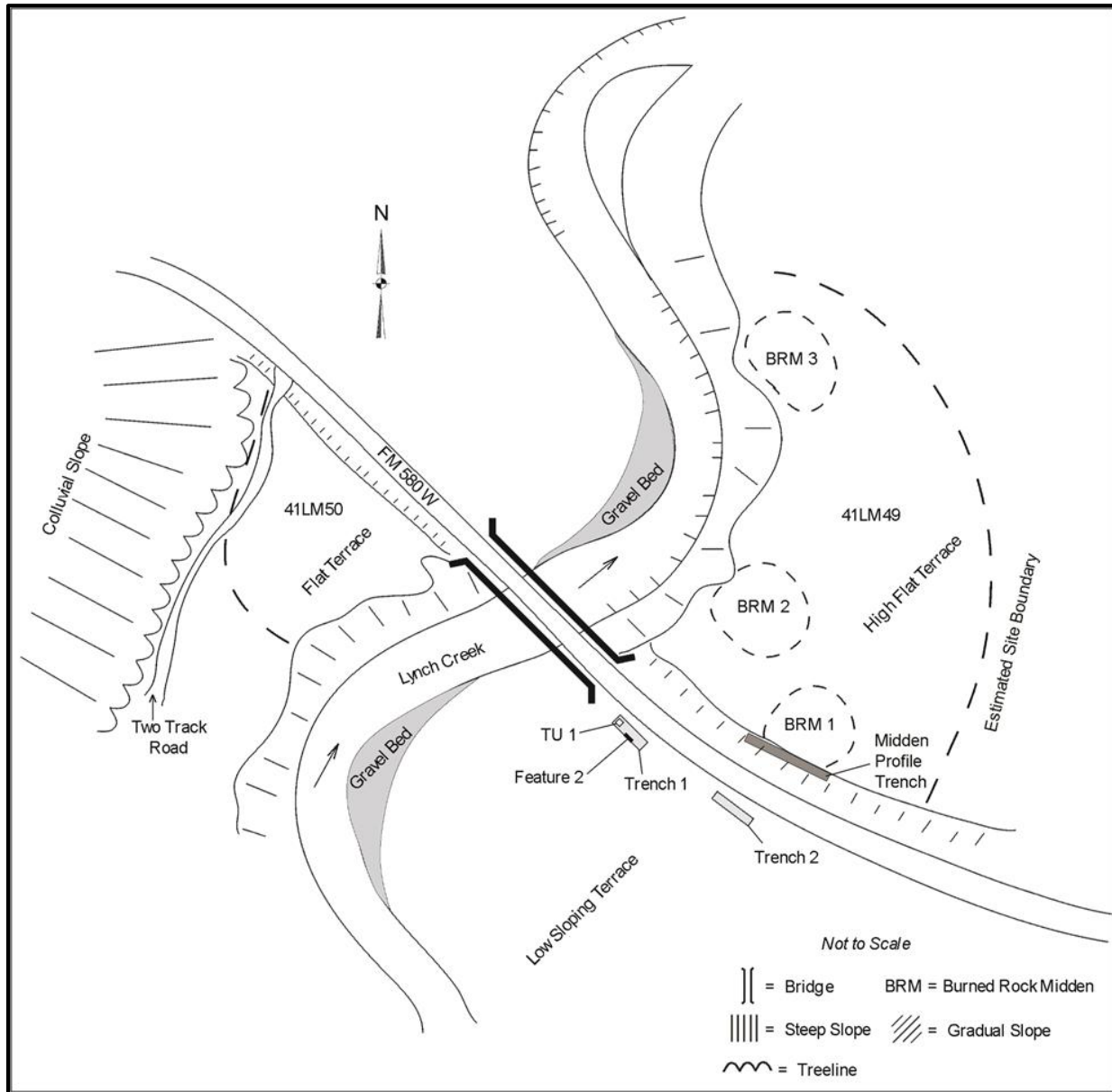
creek channel, and a small fragment of the T<sub>1</sub> surface to the north. A formal description of the deposit was not made for geoarcheological purposes, but the deposits appearance is consistent with the presumably late Pleistocene age Unit 2.

Directly opposite the mounds on the southern side of the pavement (see Figure 8-1), the deposits within the current right-of-way had been partially disturbed during original road construction, which were grass covered at the time of the investigations. That area was investigated as it had potential for buried cultural remains below the disturbed grassy surface. Two exploratory trenches and one test unit were excavated immediately south of the roadway to explore that side of the roadway.

### 8.2 SITE SPECIFIC FIELD PROCEDURES

Initially, BRM 1, also known as Feature 1, was investigated by mechanically digging a trench along the base of the northern right-of-way fence and through what remained of BRM 1 in the 4+ m tall sloping terrace deposits in the existing right-of-way (Figures 8-1 and 8-2). This trench created a vertical profile of the subsurface deposits of BRM 1, which allowed documentation of the buried part of this mound.

This profile was then systematically cleaned and brushed. The midden sediments were dry, very loose and soft, which made it difficult to retain cultural items *in situ* in the profile. Other than quantities of burned rocks, only the occasional fleck of charcoal, a chert flake or two, a few scattered *Rabdotus* shells, and a few small mussel shell fragments were exposed in the profile of the BRM. After cleaned, the profile was recorded through a scale drawing and a series of digital photographs to create a mosaic. Subsequently, samples such as burned rocks, charcoal, and *Rabdotus* shells were collected from the profile for future laboratory analyses. The locations of the collected samples were plotted on the profile drawing. Subsequently,



**Figure 8-1. Schematic sketch map of site 41LM49 and locational relationship with 41LM50.**

three small, about 25 cm wide, profiles were hand-cut along the eroding edge of the northern right-of-way fence northwest and southeast of the trench profile cut (Figure 8-2). These small windows into the subsurface were employed to help further explore for possible cultural activities next to BRM 1.

Directly opposite the mounds on the grass covered southern side of the pavement, the existing right-of-

way had been partially disturbed during previous road construction. This area had potential for buried cultural remains below the disturbed surface. That area was investigated through the digging of two mechanical trenches (Trenches 1 and 2) totaling about 12 linear meters plus one test unit (TU 1). Trench 1 was the more northern of the two (see Figure 8-1). It measured about 5 m long and 220 cm deep. In addition to complex natural stratigraphy that was intact, a small, less than 1 m long

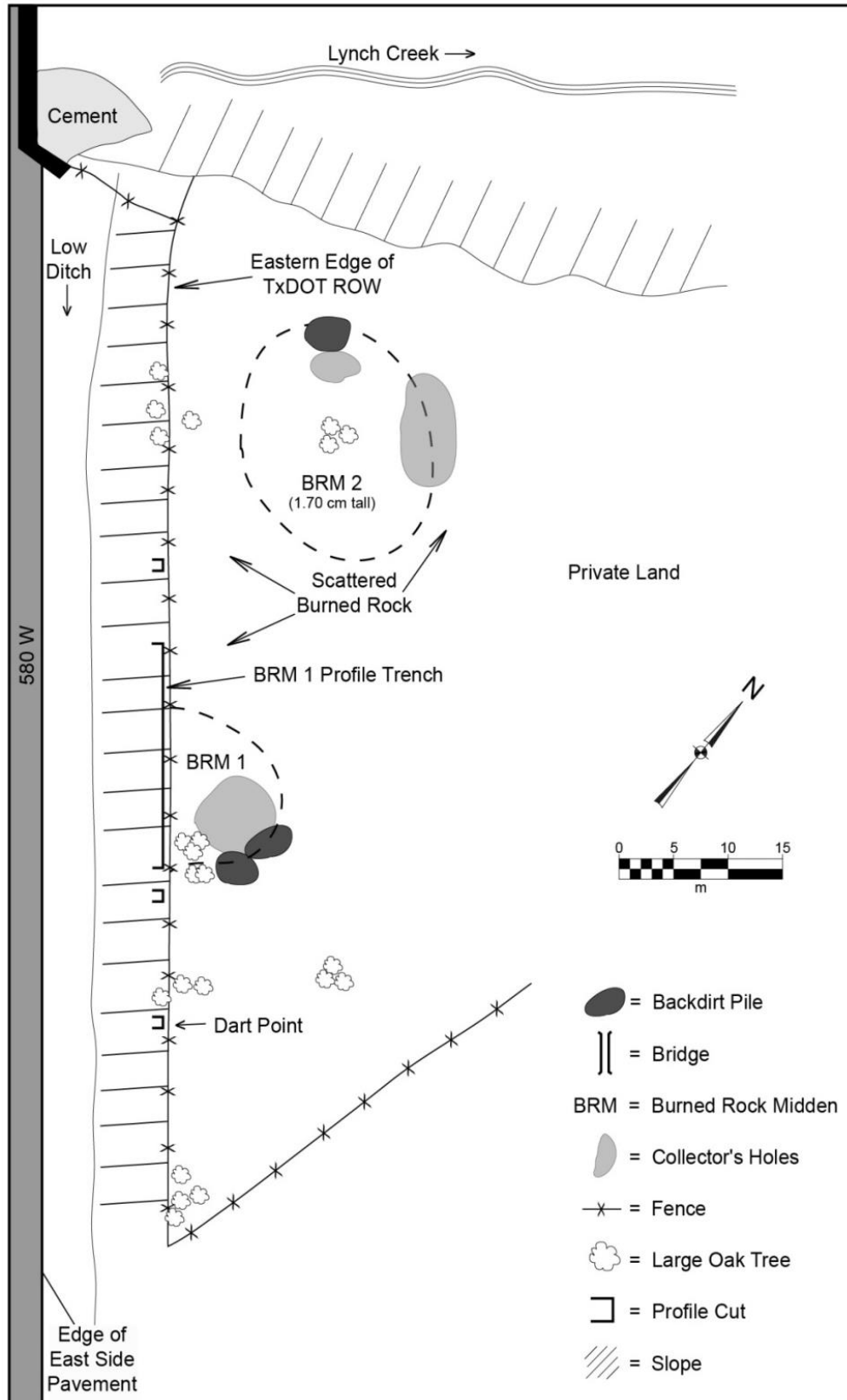


Figure 8-2. Sketch map of the portion of site 41LM49 on the northern side of FM 580W.

burned rock feature (Feature 2) was partially exposed in the western wall towards the southern end, whereas chunks of charcoal and fragmented animal bones were encountered at the northern end. The latter were in a thin AC soil horizon a few meters north of Feature 2. The multiple thin soil horizons appeared to lap up against the truncated soil zone that contained Feature 2, which was about 1 m to the south in the western profile (see Figure 7-3). The thin more horizontal soil zones with the charcoal and bones exhibited the greatest potential to yield intact cultural occupations, more so than the context in Feature 2. Therefore, the zones that contained charcoal and bone were targeted for assessment through the excavation of a 1-by-1 m test unit (TU 1). The northern end of Trench 1 was widened with the upper 170 cm mechanically removed to create a flat platform from which TU 1 was established. TU 1 was hand-excavated from a depth of 170 to 210 cmbs (0.4 m<sup>3</sup>) in four 10 cm arbitrary levels through potentially cultural-bearing sediments. The sediments from 170 to 180 cmbs were a yellowish-brown (10YR 5/4) loamy sand, followed by a grayish-brown (10YR 5/2) loamy silt from 180 to 200 cmbs, over a brown (10YR 5/4) loamy silty sand to 210 cmbs.

With the discovery of the intact Feature 2 in Trench 1, a second trench (Trench 2) was excavated about 15 m further southeast. Trench 2 measured nearly 7 m long and 230 cm deep. No cultural materials were observed in the trench walls. Consequently, no further work was conducted south of the roadway.

### 8.3 GEOARCHEOLOGICAL RESULTS

The two trenches south of the roadway exposed younger alluvial deposits. Trench 1 revealed greater than 2.5 m of Late Prehistoric age alluvium in Units 5a and 5b, with Feature 2 discovered in Zone 20 (Unit 5a) (see Figure 7-3). Trench 2 exposed an older alluvial deposit, specifically Unit 4, which is presumed to be of middle to late

Holocene age. If the age estimate of this deposit is correct and it is chronologically correlative with the middle to late Holocene alluvium recognized by Blum and Valastro (1992) for the Colorado River, it would appear that this deposit began to accumulate about the same time as the occupation of the T<sub>2</sub> surface was diminishing (assuming the 3 radiocarbon dates on *Rabdotus* shells from the subsurface BRM 1 pit adequately represent the occupation period of the higher surface).

Only one occupation surface was identified in the Holocene alluvial deposits at this site. The burned rock Feature 2 observed in Trench 1 appeared in good context and a stratigraphically isolated occupation. But as is clear from Figure 7-3 in the preceding chapter that the occupation surface accompanying this feature appeared truncated by erosion on two sides within a meter of its edges to the north and south. For this reason the occupation potentially associated with Feature 2 was not pursued.

Below the cultural materials recovered from investigations of 41LM49 are presented beginning with the features encountered. The different classes of materials recovered are then presented. This is followed by a discussion of the cultural stratigraphy, age, and geoarcheological findings for BRM 1. Then comments concerning the cultural integrity of the mound are presented. Finally, this chapter concludes with a general summary, conclusions, discussion, and finally site recommendations.

### 8.4 CULTURAL FEATURES

Two cultural features, a burned rock mound (BRM 1/Feature 1) and a small burned rock feature (Feature 2), were investigated within the existing right-of-way during this testing and evaluation program. Each feature is described and discussed below. As previously noted, BRMs 2 and 3 located on private property were not investigated.

### **8.4.1 Burned Rock Mound 1**

Burned Rock Mound 1 (BRM 1/Feature 1) was the only mound investigated at this site, as the others were on private property. This is the southernmost of three identified mounds, and is partially exposed along the very eastern edge of the existing right-of-way, in the sloping deposits below the right-of-way fence (Figures 8-3 and 8-4). Previous road construction removed an estimated 50 to 60 percent of BRM 1, leaving a 16 to 18 m partial exposure that ran east-west under the right-of-way fence. The remaining portion of BRM 1 continued about 12 to 13 m north of the fence.

The mound exhibited a 6 to 7 m wide by 50 cm deep depression on the southeastern corner, and mounded dirt and burned rock pile south and east of that depression. These likely resulted from relic collectors. It was estimated that BRM 1 rose 60 cm above the surrounding surface. The higher central part of the mound was north of the burned rock exposed under the fence, creating sloping deposits. Previous road construction created a steep cut slope nearly 5 m in height between the existing road surface to the mound surface. Burned rocks were exposed at the top of the road cut (Figure 8-4). Five or six large oak trees were growing on the southern edge of the mound.

Initially, TRC archeologists hand-excavated three small 25 cm wide profile cuts along the eroding edge of the fence to help determine the extent of BRM 1 (see Figure 8-2). These small windows guided the length of the subsequent trenching. Subsequently, mechanical trenching created a roughly vertical cut (BRM 1 Profile Trench) from the top of the road cut down approximately 1.5 m to expose the subsurface midden deposits. This trenching was monitored by an archeologist and established the horizontal boundaries in this profile via exposure of approximately 18 m of subsurface burned rocks. After exposed, the profile was systematically cleaned and brushed. The loose sediment present created difficulties in preserving

burned rocks and other materials *in situ* within the profile. After cleaned, the profile was drawn and a digital photo collage was created.

The profile was inspected several times for soil colors, obvious intrusive pits, internal structure, lithic artifacts, charcoal, sandstone burned rocks, and *Rabdotus* snail shells. Charles Frederick, the project geoarcheologist, then inspected the sediment, finalized the locations of color changes, and identified and documented each zone.

In profile, the surface of the mound was quite irregular vertically, with high and low areas (Figures 8-5 and 8-6). Many disturbances to the top of the burned rock mound were observed in the profile. Some disturbances were obvious looter holes and accompanying backdirt, some were slumped deposits, and others were of unclear causation. The bottom of the burned rock zone was also quite irregular. The subsurface burned rocks generally formed an irregular and poorly defined lens that ranged in thickness from 5 to 60 cm along the approximately 18 m exposure. The sediment that surrounded the burned rocks was dark gray-brown (10YR 4/2) loamy sand. At the very north end of BRM 1, towards the creek side, the burned rocks tapered to a single layer only a single rock thick for about 1 m. Moving southward, the burned rock lens increased in thickness, with parts of the central section as much as 65 cm thick. The southern burned rocks formed an approximately 40 cm thick lens in the undisturbed section immediately prior to an abrupt stop at a large rodent-disturbed area.

Also near the southern end was a 150 cm deep, somewhat irregularly shaped pit(s) nearly 150 cm wide (Figures 8-6 through 8-8). The pit base and sides were irregular with sides that appeared concave to somewhat “S” shaped. Diffuse, indistinct upper margins made delineation of the pit edges within the surrounding burned rock lens difficult. The overall boundaries of the pit were ill-defined due to rodent disturbances and mottled





**Figure 8-3.** Eastern edge of existing right-of-way showing steeply sloping, eroding deposits of BRM 1 exposed beneath the existing fence at 41LM49 (photograph by Allen Bettis, May 2004).



**Figure 8-4.** Close-up of eroding burned rocks in BRM 1 under fence at 41LM49 (photograph by Allen Bettis, May 2004).



**Figure 8-5. Top section of the central part of BRM 1 following vertical exposure by trenching at 41LM49** (composite photograph by Charles Frederick). Note: the pit is not shown but is below the central part of photograph.

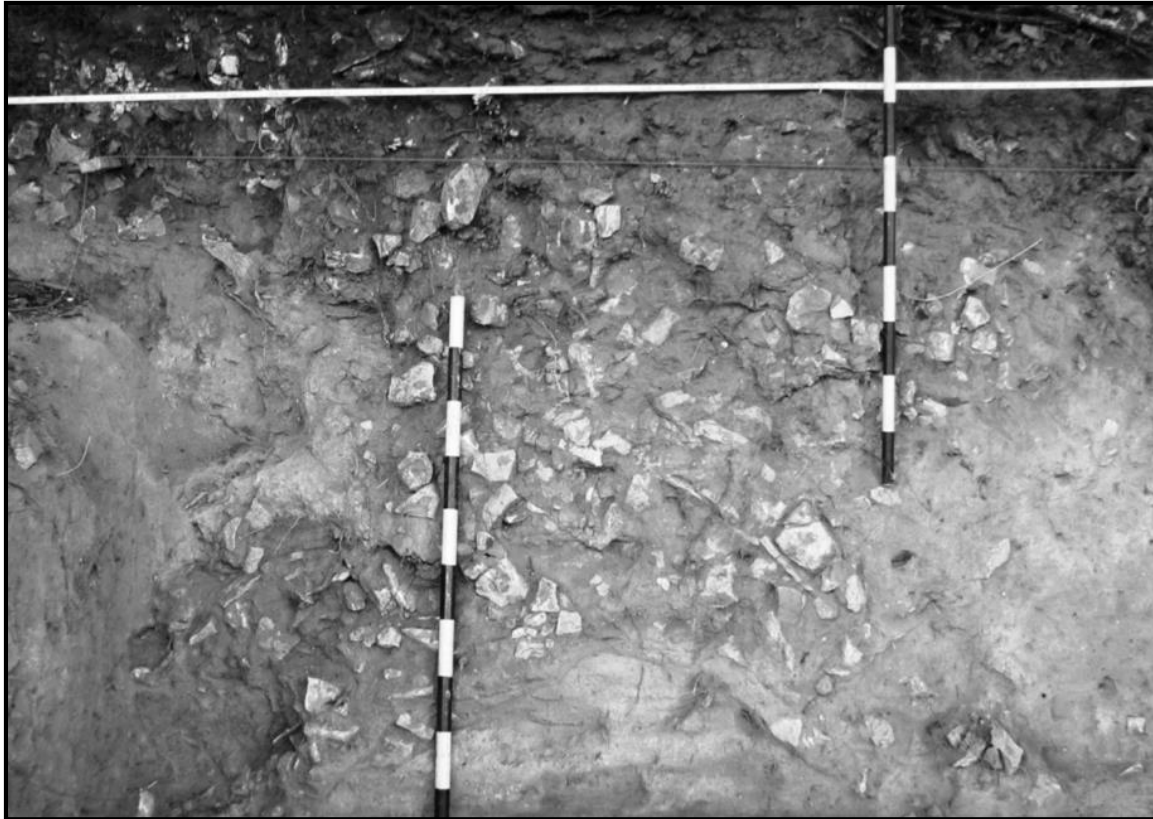
sediment changes. Rodent disturbances were especially noticeable in the southern portion and in the two segments extending laterally from the lowest portion of the pit. These lowest segments appeared to extend beyond the slightly more constricted lateral sides, which created the appearance of short wings extending on either side of a slightly raised center area across the bottom of the pit. It is possible this peculiar shape was caused by rodent activity. The interior of the pit was filled with burned rocks and dark gray-brown (10YR 4/2) loamy sand, with an occasional small snail shell, mussel shell fragment, and chert lithic. Upon closer inspection, and by wetting the sediment, two amorphous pit disturbances were discerned; the pit disturbance previously detected appeared to intrude into an older, larger underlying previous pit disturbance at the same location. The underlying older pit sediment was slightly darker brown (10YR 5/3) sandy loam and appeared to extend about 15 to 20 cm beyond the boundary of the rock filled newer pit. These overlapping intrusions were most distinct on the southern side of the pit. A large rodent-disturbed area with brown (10YR 5/3) sandy loam sediment was immediately south of the pit disturbances. The light yellowish-brown (10YR 6/4) loam that the apparent pit was dug into was harder than the intrusive and rodent-disturbed sediment fill. Most burned rocks were grayish limestone, but an occasional piece of burned sandstone was present.

In general, other than the burned rocks, very little other cultural material was observed in this long profile. No obvious chunks of organic remains or animal bones were observed.

Following the cleaning, drawing, and photographing of the profile, multiple samples of different material classes were plotted and collected from the exposed profile of BRM 1. These samples included 9 burned rocks (4 of which were sandstone), 2 tiny possible charcoal flecks, 3 mussel shell fragments (2 with hinges), 1 chert biface fragment (#1-10), 1 possible sandstone mano (#1-11), and 6 *Rabdotus* snail shells.

The wedge shaped chert biface fragment (#1-10) was recovered from approximately 50 cmbs, on the northern edge of the burned rock filled pit disturbance in the BRM 1 profile. It is a small medial fragment of a finished biface with one, nearly straight finished lateral edge and two broken edges. It fluoresces an orangish color under short-wave light, darker than most Edwards chert that has a more yellowish UV fluorescence.

During the analysis, 2 sandstone burned rocks (#1-3-1 and #1-3-8a) from 80 and 60 cmbs respectively, were selected for radiocarbon dating to determine the age of this feature. Both rocks came from the profile and were selected because they were sandstone and had potential to yield organic matter that had been absorbed into rock pores during



**Figure 8-6.** Close-up photograph of deep pit(s) exposed in profile of BRM 1, 41LM49  
(photograph by C. Frederick)

prehistoric cooking processes. See below for discussion of the age of this BRM.

Five burned rocks from different depths that ranged between 10 and 139 cmbs (3 sandstone: #1-3-4, #1-3-8a, and #1-3-9a; and 2 limestone: #1-3-3 and #1-3-2) from BRM 1 profile were sent for starch grain analysis. Three of the 5 burned rocks did not yield any starch grains. Sandstone burned rock #1-3-9a from 10 cmbs yielded two lenticular grass grains, whereas sandstone burned rock #1-3-8a from 60 cmbs yielded one unknown starch grain (Appendix D). None of the starch grains exhibited any damage from human processing.

#### **8.4.2 Feature 2**

Feature 2 is apparently an isolated occurrence, as no other cultural materials were encountered in either Trench 1 or Trench 2 during investigations on the

southern side of the roadway. Feature 2 was encountered in the western wall of Trench 1 (see Figure 8-1). Feature 2 was a tight concentration of limestone burned rocks that measured approximately 90 cm in length and 15 cm in thickness in profile. This feature is in a sloping, very dark grayish-brown (10YR 3/2) sandy loam Ab horizon zone that terminated about 60 cm to the north of Feature 2 (see Figure 7-3). This feature was not excavated, but was only exposed and observed in the trench profile. It was probed, cleaned, and photographed. Thirteen closely spaced burned rocks were observed in a linear pattern, possibly in two layers, but it was difficult to verify within the limitations of the profile. The burned rocks were relatively large, mostly intact cobbles, closely spaced over an approximately 90 cm long area that angled down to the north (Figure 8-8). The burned

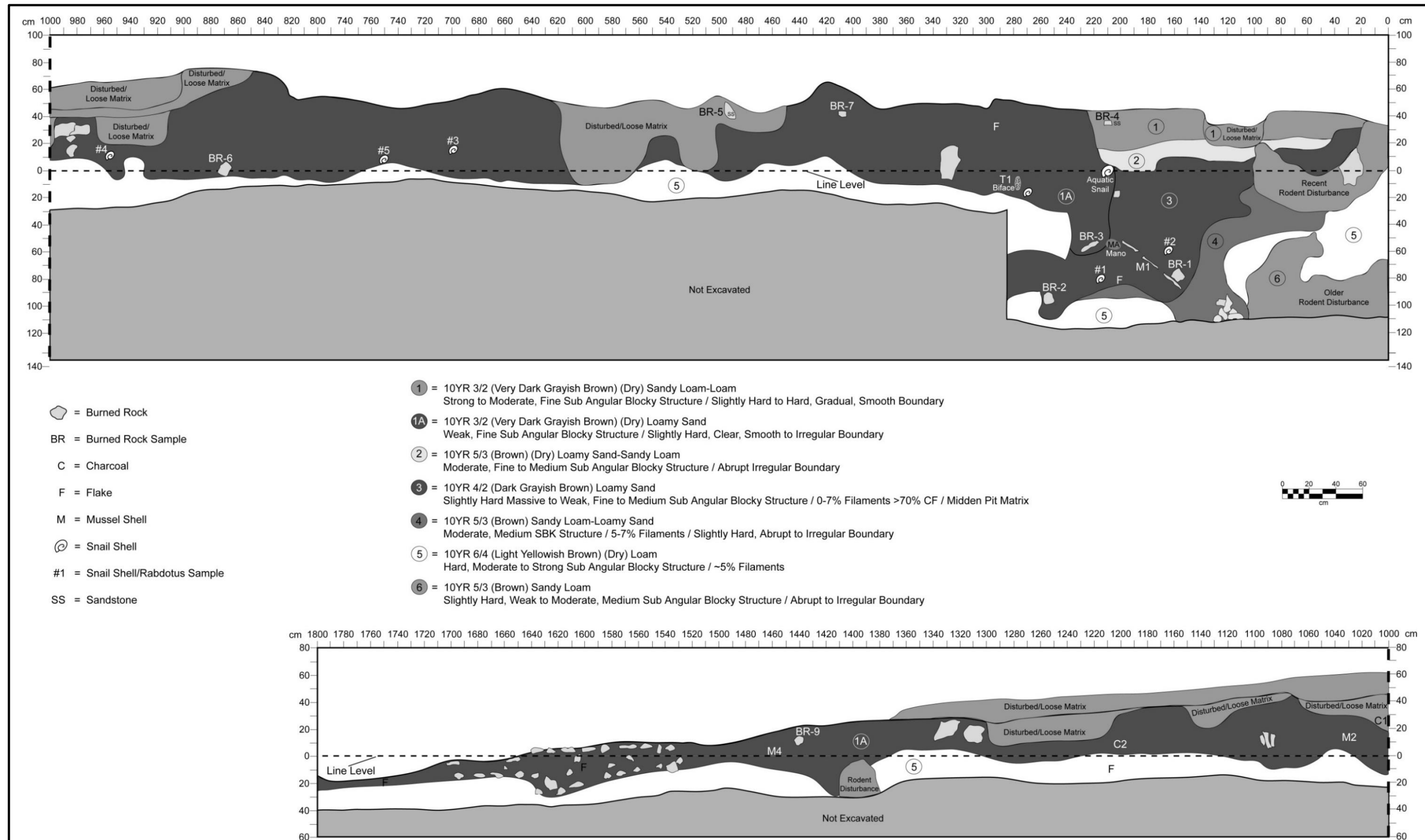


Figure 8-7. Profile drawing of Burned Rock Mound 1 at 41LM49.



rocks at the base of the feature were between 90 cmbs at the southern edge, and 120 cmbs at the northern edge, with the slope of the feature accounting for the 30 cm difference in elevation from one end to the other. No obvious charcoal lens, oxidation zone, or basin was observed below the burned rocks. Tiny flecks of charcoal were observed amongst the burned rocks. One sandstone burned rock and one charcoal sample were collected from the profile at 120 cmbs. The charcoal sample was identified as oak (Appendix H). No other cultural materials were observed on either side of this feature. No direct dating or other technical analyses were conducted on burned rocks from Feature 2. Feature 2 is interpreted as an *in situ* heating element or hearth. The age and precise function of Feature 2 is currently undetermined.



**Figure 8-8. Photograph of Feature 2, a burned rock hearth in southwestern wall of Trench 1 south of the roadway, 41LM49**  
(photograph by C. Frederick).

The chunks of charcoal and the fragmented animal bones discovered in thin sediment zones in TU 1 at the northern end of Trench 1 were not associated with any lithic debitage or burned rocks. Therefore, they were presumed not to be cultural. Charcoal samples were identified as oak and Mexican peach (Appendix H).

## **8.5 OTHER CULTURAL MATERIALS**

The proximal half (35.9 mm) of an untyped projectile point (#2-10) was from 41LM49 (Figure 8-9). This base and midsection was recovered from 0 to 10 cmbs in a 25 cm wide profile window 12 to 13 m southeast of BRM 1 along the fence line. The point was recovered from silty sand sediment, with no observed burned rock in the profile. Its association with BRM 1 is uncertain. The point is 7.9 mm thick, with a 17.2 mm narrow blade with straight, ground lateral edges. It exhibits a relatively straight, narrow 12.6 mm stem that is 5.7 mm thick, with a straight base. The edges of the entire stem are ground. It was manufactured from a local dark gray coarse-grained chert that does not fluoresce but exhibits a dark purple color under the short-

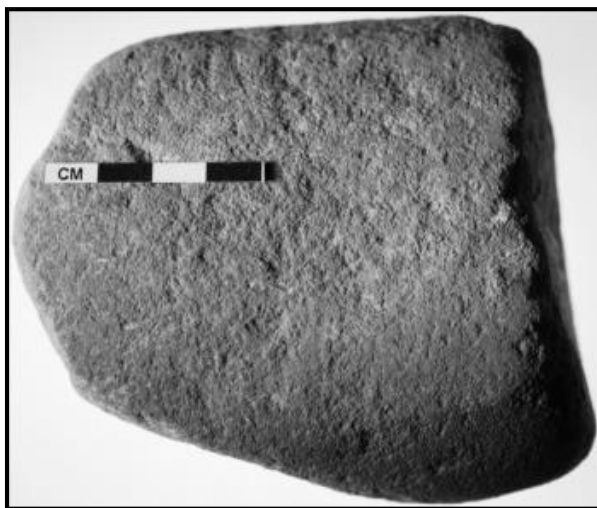
wave UV light. The surface is lightly polished to the touch, as from weathering. It exhibits an apparent use break near the midblade. The overall form and thickness is similar to a dart point; however, the narrowness of the stem could indicate that it may have been a thick arrow point or halfted biface.

A complete one-handed sandstone mano (#2-11) was from 97 cmbs in the profile of the midden TU 1. Very limited wear is visible on one surface with one lateral margin that reveals a ground beveled edge from use (Figure 8-10). Both faces are slightly convex and smoothed. However, both faces also have what appear roughly 3 cm wide ovate concave areas that could be from pecking. One lateral edge and the narrow edge both have shallow dimples that appear as peck marks or from use as a hammer. A light coating of calcium carbonate covers most surfaces. It measures 11.4 cm long by 9.37 cm wide

and 5.3 cm thick and weighs 691 g. The one limited surface has a few shallow peck marks that may indicate the surface was lightly roughened. This mano was sent for starch grain analysis, but no starch grains were recovered (Appendix D).



**Figure 8-9. Untyped projectile point (#2-10) from profile window on eastern side of BRM 1.**



**Figure 8-10. Ground face with peck marks near middle and beveled edge of complete mano (#2-11).**

## 8.6 STRATIGRAPHY AND AGE OF BURNED ROCK MOUND 1

The profile created under the right-of-way fence and through possibly the middle part of the mound revealed no discernible internal stratification, no obvious rock lined *in situ* cooking feature, almost no burned organic matter, and no diagnostic artifacts. Consequently, dating this feature was through radiocarbon dating 3 individual *Rabdotus* snail shells and 2 sandstone burned rocks collected from the deep pit(s). Three piece-plotted *Rabdotus* shells from the lower part of the deep pit were initially selected for radiocarbon dating and reported in the interim evaluation report (Table 8-1; Quigg and Frederick 2005).

Stratigraphically, the deepest shell yielded the oldest date at 6660 B.P. The other two dates fall in the range of 4460 to 4640 B.P. Since this is a midden-like deposit with indications of disturbances and a filled pit that contained these shells, it is not clear if these snail shells represent the actual use period for this mound or small intrusive elements that managed to become intertwined within the cultural deposits. To verify these *Rabdotus* dates 2 sandstone burned rocks were submitted for radiocarbon dating. The organic residues trapped in the pores of these 2 burned sandstone pieces yielded dates. Burned rock #1-3-1 from 80 cmbs yielded a date of 2660 ± 30 B.P. (Beta-345272). The second rock #1-3-8b from 60 cmbs yielded a date of 1570 ± 30 B.P. (Beta-345273, Table 8-1). The dates are in stratigraphic order with the younger rock from higher in the profile. If these two residue dates are accepted as representative of part of the cultural use period, it is still possible that the pit part is quite old, which formed in the later part of the Early Archaic and throughout the Middle Archaic cultural periods.

Although the earliest date is somewhat earlier than most would expect or generally accept for the use periods of mounds, the 6660 B.P. date is not out of the realm of possible use. BRM 1 at 41BL598 in



**Table 8-1. Radiocarbon Data and Results from 41LM49.**

Cat. No.	Unit No.	Depth (cmbs)	Feature No.	Material Dated	Lab. No.	Measured Age	<sup>13</sup> C/ <sup>12</sup> C Ratio (‰)	Conventional Age (B.P.)	2 Sigma Calibration Range
1-6-1	BRM profile	141	BRM 1 pit	1 <i>Rabdotus</i>	UGA-14415	6390 ± 50	-8.41	6660 ± 50	5670-5480 BC
1-6-2	BRM profile	98	BRM 1 pit	1 <i>Rabdotus</i>	UGA-14416	4460 ± 50	-8.92	4460 ± 50	3350-2920 BC
1-6-5	BRM profile	45	BRM 1 pit	1 <i>Rabdotus</i>	UGA-14417	4360 ± 40	-8.01	4640 ± 40	3620-3340 BC
1-3-8	BRM profile	60	BRM 1 pit	Sandstone burned rock residues	Beta-345273	1530 ± 30	-22.4	1570 ± 30	AD 420-560
1-3-1	BRM profile	80	BRM 1 pit	Sandstone burned rock residues	Beta-345272	2620 ± 30	-22.8	2660 ± 30	840-800 BC

Fort Hood also yielded seven radiocarbon dates (6 on *Rabdotus* shells and 1 on charcoal) that are older than 6000 B.P. (Quigg and Ellis 1994). In western Texas in the Lower Pecos region a burned rock midden associated with other cultural materials was recognized in Analytical Unit 6 at Hinds Cave (Lord 1984; Williams-Dean 1978). The Hinds Cave burned rock midden was about 1 m thick with no obvious central pit. The midden was radiocarbon dated to between 6540 ± 70 B.P. (Tx-2744) and 6160 ± 80 B.P. (Tx-2735) and apparently was associated with Bandy points (Lord 1984; Shafer and Bryant 1977; Turpin 1991). It yielded massive charcoal deposits, charred bases of lechuguilla remains, quids of lechuguilla and sotol, and cut leaf bases on the western edge. The Hinds Cave midden may be one of the earliest, clearly dated burned rock middens in Texas.

The *Rabdotus* dates could also predate the use period and represent old shells that became incorporated into the pit at some point during the use period or after. These snails may have also ingested old carbon from the limestone. The two younger burned rock dates likely represent use periods younger than the pit. These two dates are in line with many other radiocarbon dates obtained from middens (see Black and Creel 1997). These two residue dates are believed to document part of the use period, whereas the older *Rabdotus* dates are in question, and likely do not date actual use periods.

### 8.6.1 Comments on the Contextual Integrity

The integrity of the BRM 1 is difficult to assess given the limited nature of the work performed. But the discovery of a deep, flared bottom pit(s) filled with burned rock indicates that this feature retains some stratigraphic integrity. Pit features such as this, specifically discrete pits filled with burned rock debris, have been noted in burned rock middens/mounds elsewhere in central Texas (i.e., Quigg and Elis 1994). For instance Brownlow et al. (2004:6-7; Figure 19) discovered part of a large burned rock midden filling a 4.5 m wide by 1.5 m deep depression formed in limestone (presumed to be a karstic solution pit) that had some stratigraphic features that resembled single event refuse discard deposits. One can debate whether the pit observed by Brownlow et al. (2004) represented exploitation of an existing natural feature, human augmentation (by digging) of a natural feature, or a purposefully dug pit, but the feature observed appeared intentionally created. The pit in BRM 1 was excavated into the subsurface and subsequently filled with burned rock refuse. Why it was originally excavated (assuming it is an original feature rather than the by-product of vandalism, for which there was no supporting evidence) remains unknown. The primary function of such deep pits is generally associated with the actual cooking locality. It is clear that the pit preserves primary refuse, and analysis of such features when they are discovered may provide new insights on cooking related behavior at sites like these.



## 8.7 SUMMARY, CONCLUSIONS, AND DISCUSSION OF 41LM49

### 8.7.1 Summary

Given no new right-of-way was proposed for the proposed bridge replacement in the area of 41LM49, our investigations were conducted within the existing, previously disturbed right-of-way. Previous TxDOT construction activities had impacted this site, that left one burned rock mound (BRM 1) exposed in a truncated T<sub>2</sub> terrace deposit, at the very northern edge of the existing right-of-way, under the fence. Most of what remains of burned rock mound site 41LM49 lies north of the existing right-of-way, on private property.

The archeological investigations within the existing right-of-way documented one partially destroyed burned rock mound (BRM 1). Work focused on the portion of BRM 1 exposed under the northern right-of-way fence at the eastern edge of the project area. A profile of BRM 1 was mechanically created, documented (drawn and photographed), and samples collected from the profile (*Rabdotus* shells, charcoal, chert flakes, and burned rocks) for possible future analysis.

The southern side of the roadway was also investigated through mechanically digging two geoarcheological trenches to assess the alluvial deposits, and the hand-excavation of one 1-by-1 m test unit (TU 1) within the northernmost portion of Trench 1 to target soil zones that contained fragmented animal bones and charcoal. TU 1 was hand-excavated and screened from 170 to 210 cmbs (0.4 m<sup>2</sup>) to assess these discoveries. These materials were later determined not to be cultural.

### 8.7.2 Conclusions and Discussions

The profiling of BRM 1 along the edge of the existing right-of-way documented a nearly 18 m long subsurface burned rock lens that varied from 10 to 150 cm thick. The majority of the buried burned rock lens varied between 30 and 60 cm

thick, with a deep, roughly 150 cm diameter rock filled pit(s) that extended to roughly 150 cmbs near the southern end of the lens. Other than the deep, rock filled pit(s) that extended below the broader lens of burned rocks, little else was unusual about the subsurface contents of BRM 1. Very tiny charcoal flecks, a few pieces of lithic debitage, and sparse snail shells were observed in the profile. Three individual *Rabdotus* snail shells from the pit(s) were radiocarbon dated, and yielded corrected dates of 6660 B.P., 4640 B.P., and 4460 B.P. These radiocarbon dates on the *Rabdotus* shells are unlikely to represent the true age of the cultural activities associated with the burned rocks, as BRM 1 would be significantly older than the majority of the 16 burned rock mound sites previously tested at Camp Bowie in nearby Brown County, which were primarily used over the last 1,500 years (Mauldin et al. 2003). The two radiocarbon dates derived from organic residues in two burned rocks yielded dates of 1570 B.P. and 2660 B.P. These two dates more closely reflect the possible use period for this mound.

The presence of the deep, rock filled pit(s) may support the interpretation that BRM 1 represents a central *in situ* pit cooking feature and accompanying massive discard of used burned rocks employed within the feature. The deep pit(s) potentially represents the primary or central cooking locality, surrounded by quantities of broken and discarded burned rocks from the cooking processes. However, some identified central pit cooking features in similar middens were lined with large rock slabs (i.e., Black 2003; Collins 1994:103-110; Quigg 2011a), creating some uncertainty as to the function of this rock filled pit. The relative lack of preserved organic remains within the mound precludes identification of types of foods potentially cooked within this feature.

Starch grain analysis on artifacts, including a mano and five burned rocks, attempted to address what foods may have been cooked in the feature. Two

burned rocks yielded a total of three starch grains. One rock (#1-3-9a) yielded two lenticular grass grains, and a second rock (#1-3-8a) yielded an unidentified grain. No cultural damage was observed on the three starch grains. The identification of grass starches present does not necessarily clarify what food resources were utilized, as the lack of cultural modification may indicate the grasses had not been the targeted food resource itself, but rather packing material around other food resources. The mano did not yield any starches (Appendix D). Few ground stone artifacts from the central Texas region have been analyzed for starch grains. The only other known samples, a mano (#176) and a metate (#198) from buried context at Cowdog Crossing (41CV389) in Coryell County, just to the northeast, were analyzed, but again no starches were observed (Cummings and Varney 2010). These latter two artifacts were part of broader assemblages that date from about 1,000 to 2,000 years ago during the Late Archaic.

Other burned rock mounds/midden sites are present throughout Lampasas County. Approximately 20 percent of the total recorded sites in Lampasas County are classified as burned rock middens (Mauldin et al. 2003), and similar frequencies of burned rock middens are present in the surrounding counties. Therefore, the occurrence of these mounds at 41LM49 is not unusual (see Black et al. 1997; Mauldin et al. 2003 for extensive discussions of the age and functions of these features).

South of the roadway, the two geoaerchological trenches exposed very sparse cultural debris in the alluvial deposits, and a buried, apparently isolated, small burned rock heating element (Feature 2). No cultural materials were observed directly associated with this Feature 2. Feature 2 rested on top of a coarse sediment deposit, indicating this feature was created in a depositional setting, possibly a gravel bar, and subsequently buried by more recent fines. Lacking suitable materials for radiocarbon results, neither Feature 2 nor the non-feature materials were

dated. Geoaerchological interpretations of the deposits that contained Feature 2 indicate the deposits are of Late Prehistoric age, likely less than 1,300 years old. If so, Feature 2 and other materials south of the road are not associated with the BRMs north of the road.

## **8.8 RECOMMENDATIONS FOR 41LM49**

The project area, located within the existing TxDOT right-of-way, east of Lynch Creek Bridge, was assessed. No new right-of-way was proposed for this immediate project area. Previous construction of FM 580W removed an unknown portion of previously unrecorded site 41LM49 from within the existing right-of-way. Minimally two and a half burned rock mounds remain beyond the existing right-of-way. The project area contains only a linear truncated edge of BRM 1 below the existing northern right-of-way fence. This small window into BRM 1 was the focus of the archeological investigation and was recorded in detail, samples collected and some were analyzed. Two mechanical trenches were dug within the existing right-of-way on the southern side of the pavement to investigate the potential for subsurface cultural deposits and document the natural deposition in that area. The trenches revealed one small isolated burned rock hearth feature, but no associated occupation lens or component. Site 41LM49 was recorded, site forms completed, and a sketch map was produced.

TRC archeologists have documented the portion of previously unrecorded site 41LM49 within the existing, previously disturbed right-of-way. Very limited cultural remains still exist within the existing right-of-way, and those that are present are not eligible for listing on the NRHP or significant enough to designate as an SAL. On the basis that no new right-of-way is proposed, and the cultural resources within have been documented, we recommend no further archeological work within the existing right-of-way at site 41LM49.

*This page intentionally left blank*

## **9.0 TESTING RESULTS AT 41LM50**

J. Michael Quigg, Paul M. Matchen, and Charles D. Frederick

### **9.1 INTRODUCTION**

This chapter presents the findings from the August 2004 eligibility testing investigations within the proposed temporary easement through part of site 41LM50. This was a previously unrecorded prehistoric site in the southwestern quad of Lynch Creek Bridge East. At 41LM50, Lynch Creek flows roughly west to east whereas the highway crosses Lynch Creek north and south. Cultural materials were discovered in deep Holocene alluvial terrace deposits immediately north of the creek and west of the road (Figure 9-1). This site consists of multiple occupations within the T<sub>2</sub> terrace. Here the T<sub>2</sub> surface is nearly flat, with the gently southeastward sloping surface that meets the channel of Lynch Creek at a high (ca. 6 m) steeply sloping to a vertical cut bank. The terrace is covered with many large and small oak trees, small juniper and mesquite trees, persimmon bushes, prickly pear, with sparse grasses between the trees and in open areas (Figure 9-2). A private two-track road crosses the northern edge of the terrace near the base of the colluvial slope. North of the two-track road, the slope is covered with limestone bedrock and individual limestone rocks eroding downslope and out across the back edge of the alluvial deposits.

Previous construction of FM 580W removed roughly the upper 150 cm (5 ft.) of the terrace within the existing FM 580W right-of-way, with the exception of about a 1 m wide strip of undisturbed deposits that parallels the right-of-way fence along the southwestern side of the pavement. The existing right-of-way between the site and the pavement contains a low drainage ditch with low concrete barriers perpendicular to the drainage that

occasionally carries runoff to the creek below from higher ground to the north. The proposed temporary easement on the western side of the pavement crosses private land and will extend about 10 m (30 ft.) further west from the existing right-of-way and about 109 m (356 ft.) to the north from the northern edge of the bridge. The roadway proposed for this temporary low-water crossing will merge with the existing roadway just past the rocky colluvial slope (Figure 9-1).

### **9.2 SITE SPECIFIC PROCEDURES**

A metal gate to the private two-track road across the terrace and the APE allowed the backhoe access to the proposed easement. Two mechanical trenches that totaled nearly 14 m in length were excavated into the Holocene alluvial deposits. Both trenches were along the very western edge of the proposed easement and south of the rocky outcrops and colluvial slope (Figure 9-1). Because of the depth of the natural deposits a safety bench/step was created in each trench that formed irregularly shaped rectangular trenches. Trench 1 measured about 7 m long by a maximum of 4 m wide and was towards the southern end of the APE just above Lynch Creek and about 2 m north of the drop off. The initial mechanical scraping of the southern edge of Trench 1 uncovered a concentration of burned rocks immediately under the surface (later designated part of Feature 1). Trench walls were examined for cultural materials and the geoarcheologist documented the depositional sequence exposed. Occasionally burned rocks and lithic debitage were detected in the trench profiles to a depth of approximately 70 cmbs.

Three samples were collected from Trench 1 walls. A tiny charcoal sample was extracted from Zone 3, a clay ABKs horizon, near 98 cmbs. One bulk sediment sample was extracted from Zone 4, a BKss horizon at roughly 90 to 98 cmbs. A second bulk sediment sample was collected from Zone 5, a clay BK horizon at 145 to 155 cmbs. These samples

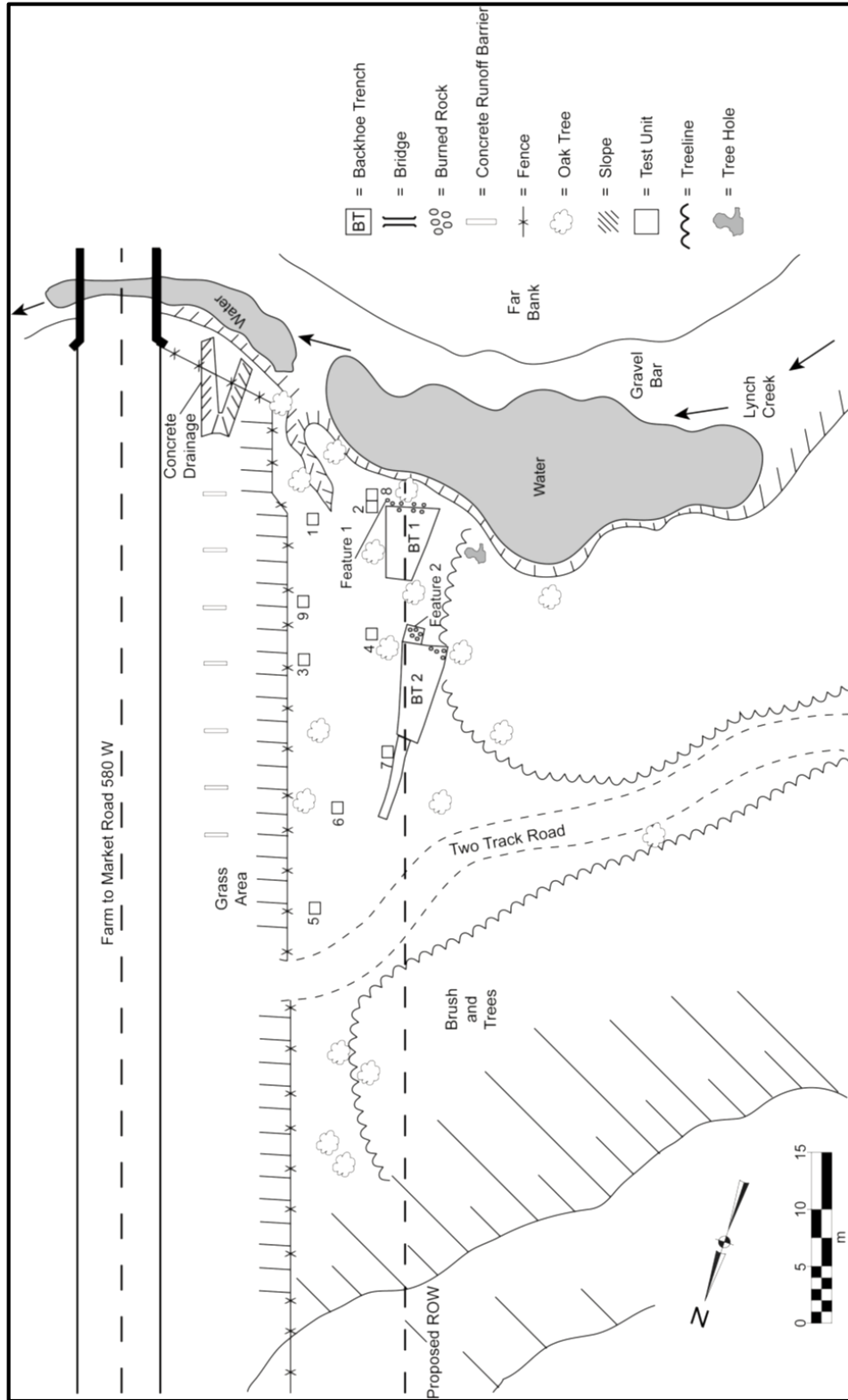


Figure 9-1. Plan sketch map of site 41LM50 that shows the investigated areas in the temporary proposed easement on west side of the current right-of-way.



**Figure 9-2. View east of proposed easement and east end of terrace with excavation units in progress at 41LM50.**

were collected in anticipation of using them for radiocarbon dating the deposits and other analyses.

Trench 2 was excavated about 6 to 7 m north of Trench 1. This trench measured nearly 16 m long with a maximum width of 4 m. The initiation of Trench 2 also encountered a cluster of burned rocks (later assigned Feature 2) immediately below the surface at the southeastern edge, and again the trench was moved slightly westward and northward.

A burned tree with chunks of charcoal and obvious red oxidized sediment was also detected in the southwestern side of Trench 2. The geoarcheologist documented the depositional sequence observed in the two trenches (Figure 9-3; see Chapter 7.0 for interpretations and Appendix A for trench details).

Nine test units assigned TUs 1 through 9, which encompassed 6.5 m<sup>3</sup>, were hand-excavated across the terrace at the southern end of the APE (see Figure 9-1). TU 2 was adjacent to the clustered burned rocks exposed by Trench 1, with TU 8 excavated on the southern edge of TU 2 to further investigate the burned rocks encountered in TU 2. The other seven test units were distributed

arbitrarily to sample the 10 m wide by about 50 m long easement across the terrace and through a portion of this site. The second cluster of burned rocks (Feature 2) at the southern end of Trench 2 appeared beyond the potential eastern boundary of the easement. Therefore, no formal excavation of the uncovered rocks occurred. However, this partially disturbed burned rock cluster was hand-troweled to expose the rocks. The rocks encountered were mapped, and a few lithic materials and a couple of charcoal samples were collected. Plan views of the two partially exposed burned rock features (Features 1 and 2) were drawn, but the features were not entirely excavated. Consequently, their overall shape and contents were not fully documented. Wall profiles were drawn of TUs 4 and 7.

A sketch map of the site was drawn and included the proposed temporary easement, the locations of the 1-by-1 m test units and the mechanical trenches, as was the western side of the existing right-of-way, the existing right-of-way fence line, and tree line boundaries. A sketch map of the site was drawn and included the proposed temporary easement, the locations of, the 1-by-1 m test units and the

mechanical trenches, as was the western side of the existing right-of-way the existing right-of-way fence line, and tree line boundaries (see Figure 9-1).

In the following sections the cultural materials recovered from all test units are presented beginning with the two features encountered. This is followed by the presentation of the classes of materials recovered. Then comes the discussion of the vertical distribution of the cultural stratigraphy, age, and geoarcheological findings for each identified cultural component, with comments concerning the cultural integrity of those components. This is followed by a presentation of the individual cultural components by time period. Finally, this chapter concludes with a general summary, discussion, and site specific recommendations.

### 9.3 CULTURAL FEATURES

One prehistoric burned rock feature (Feature 1) was recognized and partially sampled in the 6.5 m<sup>3</sup> of hand-excavations, with another burned rock feature (Feature 2) exposed at the beginning of Trench 2 excavation and subsequently documented. Each feature is described and interpreted in the following sections.

#### 9.3.1 Feature 1

Feature 1 was encountered at the southern end of Trench 1, immediately below the grass covered ground surface at the initiation of trench excavation (see Figure 9-1). A concentration of rounded burned rocks was exposed as the backhoe bucket made the initial pass. To investigate this concentration, TU 2 was established 30 to 35 cm east of the trench-exposed portion. Excavations in TU 2 encountered part of Feature 1 in the southwestern corner between 14 and 24 cmbs, in a very dark gray (10YR 3/1) hard clay loam (Figure 9-4).



**Figure 9-3.** Photograph of hard dense clays in Trench 2 wall profile at 41LM50, view east.

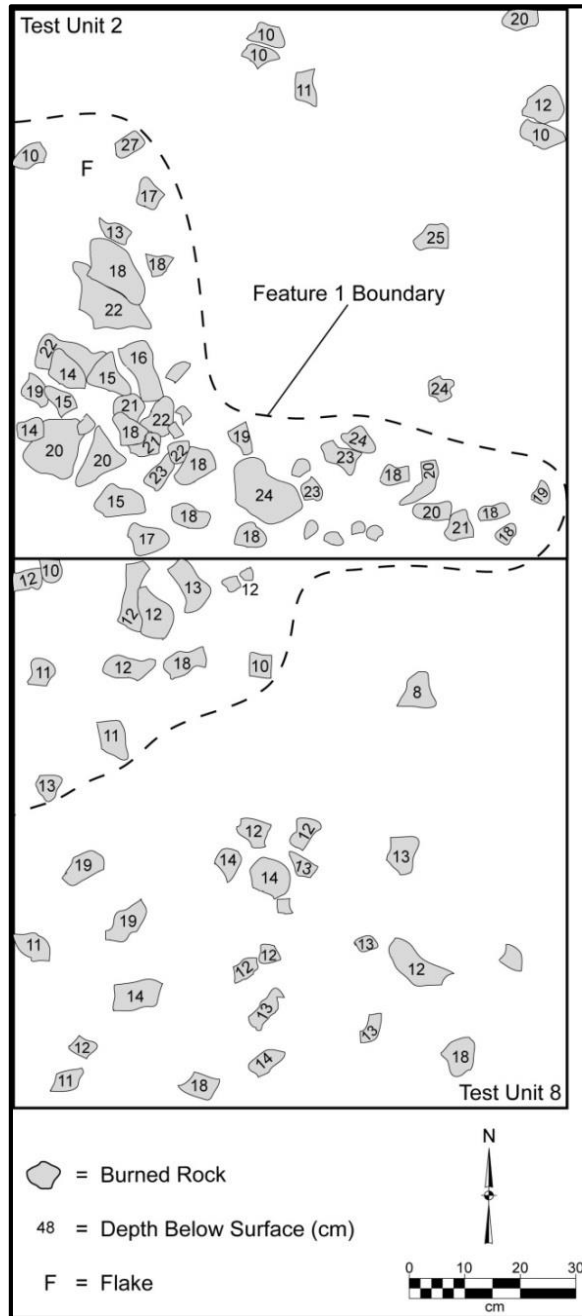


**Figure 9-4.** Feature 1 burned rock distribution in southwestern quadrant of TU 2 at 41LM50.

To further expose Feature 1, TU 8 was excavated on the southern edge of TU 2. The burned rocks within the two test units were exposed by troweling, digitally photographed, and drawn in plan view.

The basal elevations and sizes of individual burned rocks were recorded on the test unit level records, weighed, and counted by size category.

Once excavation of both test units was completed, and data for level forms recorded, a feature form was completed to record general observations,



**Figure 9-5. Plan view drawing of burned rocks in TUs 2 and 8 as part of Feature 1 at 41LM50.**

details of construction, evidence of disturbances, associated artifacts, and other aspects of Feature 1. The two hand-excavated units did not encompass the entire feature, but sampled only the northern and eastern part of Feature 1. Consequently, the overall shape and size of the entire feature and the

total number of burned rocks and associated artifacts is unknown.

The more concentrated part of Feature 1, as observed in the two excavated units, measured roughly 100 cm east-west, and 90 to 100 cm north-south, with scattered rocks in the vicinity. However, the boundaries are poorly defined with scattered burned rocks at the same levels, which made the current boundary largely arbitrary (Figure 9-5). The two excavated units contained cumulatively 68 predominately rounded burned rocks that weighed about 11,550 g, for an average weight of 170 g per rock. Of the burned rocks encountered, 29 percent were less than 4 cm in size, 49 percent were between 4.1 and 9 cm, and 22 percent greater than 9.1 cm in diameter. Most rocks were weathered, water rounded limestone cobbles, with less than 10 percent sandstone chunks. Rocks appeared randomly dispersed with no detectable pattern or specific orientation. No basin, charcoal, or oxidized sediments were observed around these burned rocks. The sediment color was the same outside the feature and inside the clustered burned rocks. The bottom elevations of rocks varied from as shallow as 10 cmbs to as deep as 25 cmbs. A few larger pieces were directly below smaller pieces, which might indicate a possible shallow basin was present, or the rocks were dumped and did not all land on a flat ground surface. Five limestone and 3 sandstone burned rocks were collected for potential analyses.

Two sandstone burned rocks (#68-3-2 and #69-3-1a), one from 10 to 20 cmbs and the other from 23 cmbs respectively were selected for directly dating potential organic residues in the rocks. Rock #68-3-2 yielded a  $\delta^{13}\text{C}$  (-23.0‰) corrected date of  $430 \pm 30$  B.P. Rock #69-3-1a yielded a  $\delta^{13}\text{C}$  (-23.0‰) corrected date of  $330 \pm 30$  B.P. (Appendix B for details on the dating results).

Seven burned rocks, 3 sandstone (#69-3-2, #70-3-3, and #70-3-2) and 4 limestone (#68-3-1, #70-3-5, #70-3-4, and #70-3-1), were selected and sent for starch grain analysis.



Dr. Perry's procedures and results are presented in detail in Appendix D. A summary of the findings is presented here. Two limestone burned rocks (#70-3-5 and #70-3-4) and one sandstone rock (#70-3-2) yielded starch grains. A maize grain, a possible maize grain, and one grass grain were recovered. The grass grain also exhibited signs of heat damage. The latter may indicate this grass was used as starter fuel in the fire to heat the rocks or potentially a food resource.

A phytolith sample (#69-4) was collected in TU 2 from under a burned rock at 23 cmbs and analyzed. It was anticipated that some plant food resources processed by the burned rocks would be discovered in this sediment sample. This presumably cultural sample was compared with the presumed natural sediment sample (#41-4) from 18 cmbs in TU 6. Dr. Sudbury's procedures, results, and interpretations are presented in Appendix F. Sample #69-4 yielded nearly equal percentages of the three major short cell phytoliths with 31.2 percent cool season Poidids, 37.3 percent warm moist season Panicoids, and 31.4 percent hot dry Chloridoids. These percentages significantly differed from the natural sample that yielded 21 percent cool season Poidids, 42.8 percent warm moist season Panicoids, and 35.9 percent not dry Chloridoids. Short cell burned phytoliths account for 4.3 percent (9.5 cells). Burned tree phytoliths account for 0.43 percent of the assemblage.

However, no evidence of gathered seeds or food resources were detected (Appendix F). The data indicates a possible cool season, spring or fall, occupation based on this short cell phytolith assemblage. The frequencies of these indicate this time period hotter than today, with hotter summers and shorter cool seasons (Appendix F).

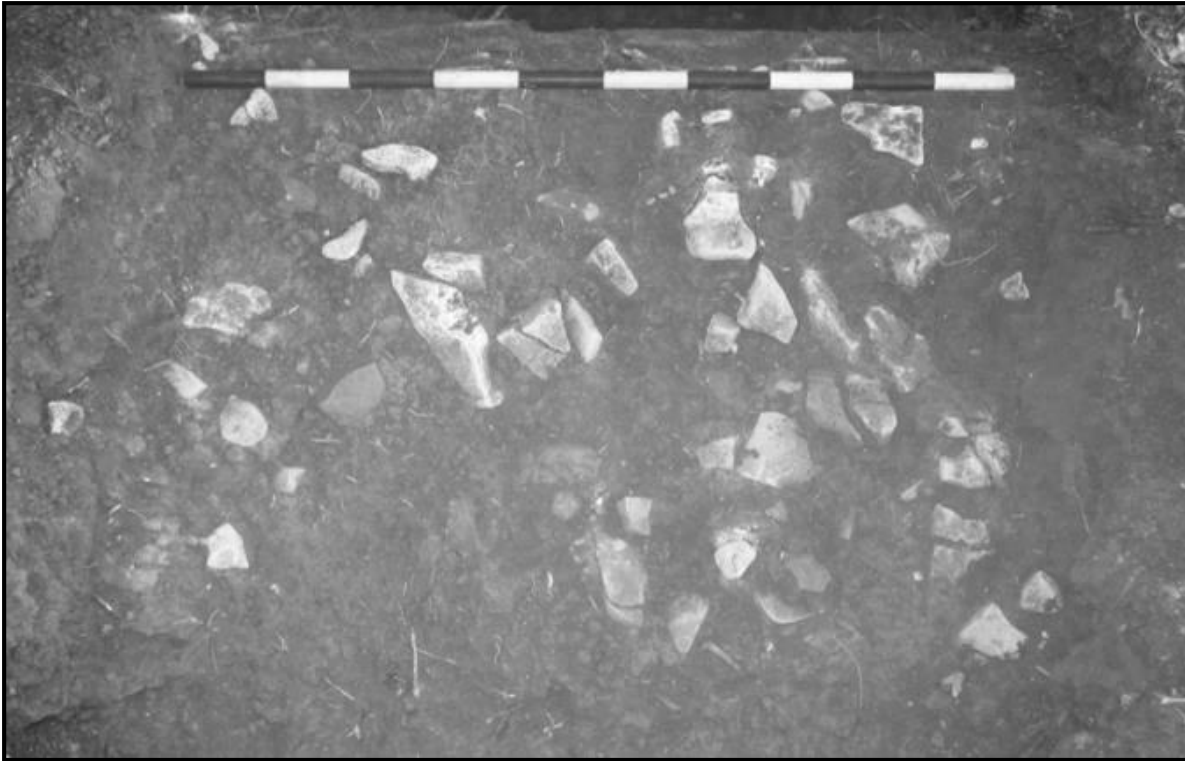
Other than the burned rocks, 91 pieces of lithic debitage, 3 edge-modified flakes (#10-10, 10-11, and #53-10), 1 broken biface fragment (#54-10),

and 1 Bonham arrow point (#68-10) were encountered and collected in Levels 1 through 3 of TUs 2 and 8. The Bonham point was associated with Feature 1, and was recovered from within the concentration of burned rocks in the southwestern corner of TU 2. The base of a Pedernales dart point (#9-10) and a biface fragment (#9-11) were from the top 10 cm of TU 2 and generally above the feature rocks. The Pedernales base was found *in situ* at 10 cmbs and above most burned rocks. Biface fragment (#54-10) was *in situ* at 27 cmbs in TU 8. The frequency of the burned rocks and lithic debitage dropped off sharply between 30 and 40 cmbs in both test units.

The current data indicates that this loose cluster of burned rocks and scattered lithic debitage and stone tools probably represent a discard pile of rocks previously used for cooking and other unwanted materials. Based on the dates derived from the two burned rocks, this discard occurred during the Late Prehistoric period, within the last 450 B.P. The Bonham arrow point also indicates a relatively late date for this feature. See the radiocarbon dates from Feature 2 within this same cultural occupation zone.

### 9.3.2 Feature 2

This burned rock feature was first detected at the start of digging Trench 2, with the first bucket scrape of the grass layer about 5 to 7 cm deep (see Figure 9-1). The trench was moved about 1 m north to avoid additional impact to the burned rocks. The initial bucket scrape removed an estimated 60 cm long by 100 cm wide part of this burned rock concentration. Burned rocks were still present on the southern and northern sides of that initial scrape. The burned rocks left partially exposed were in a section about 90 cm long by 100 cm wide (Figures 9-6 and 9-7). However, after recalculating the proposed easement width it was estimated this cluster of burned rocks was likely just beyond the proposed easement boundary.



**Figure 9-6. Feature 2 burned rocks following exposure with backhoe.**

Therefore, Feature 2 was not formally excavated within the confines of 1-by-1 m test units. The 100-by-90 cm partially scraped area was hand-troweled to expose the nature of the burned rocks and associated materials, drawn in plan view, and recorded. The basal elevations of the artifacts encountered were recorded and a feature form completed. This limited exposure sampled an unknown portion of Feature 2; therefore, the overall shape and size, the total number of burned rocks, and other characteristics were undetermined.

The small investigated partially disturbed stripped section of Feature 2 revealed 124 burned rocks that weighed 8,762 g cumulatively with an average rock weight of 70 g. Only 16 pieces (13 percent) were greater than 9.1 cm in length, with 87 percent of the burned rocks less than 9 cm in overall length. Most burned rocks were limestone, with a few intermixed sandstone pieces. No patterning or formal orientation to the burned rocks was discernable. The basal elevations ranged from 8 to 19 cmbs

(Figure 9-8). A sample of 9 burned rocks (both sandstone and limestone), 2 charcoal samples, 1 biface fragment, and 42 lithic flakes were collected. No charcoal lens or oxidized area was observed, and no basin was detected.

Nine burned rocks, 4 limestone (#71-3-4, #71-3-5a, #71-3-7a and #71-3-9) and 5 sandstone (#71-3-1, #71-3-2, #71-3-3, #71-3-6, and #71-3-6a), were selected and sent for starch grain analysis. Dr. Perry's procedures and results are presented in detail in Appendix D. In summary, only two rocks yielded starch grains. Rock #71-3-1 yielded an unknown grain that was gelatinized. Specimen #71-3-3 yielded a grass grain that was also gelatinized. The gelatinized grains indicate they came in contact with heat and water and therefore likely part of the food resource.

Forty-two pieces of lithic debitage, one biface fragment (#71-10), and at least 4 edge-modified flakes (#71-11, #71-12, #71-13, and #71-14) were

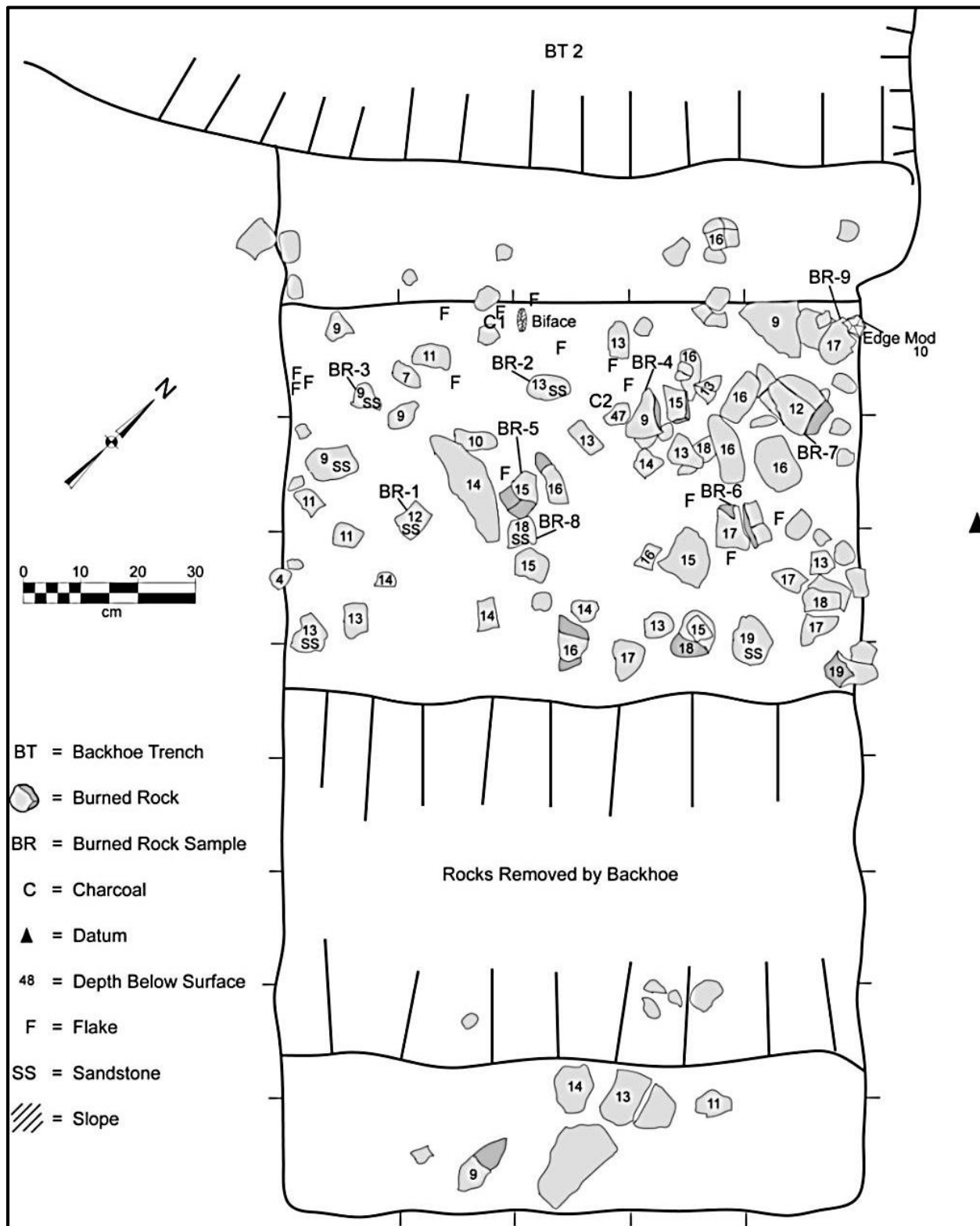
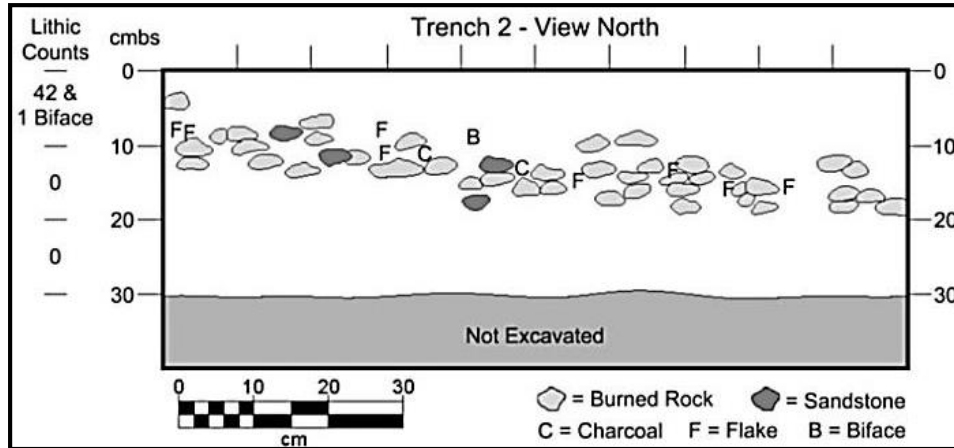


Figure 9-7. Plan view of Feature 2 that depicts distribution of burned rocks in backhoe scrape at 41LM50.



**Figure 9-8. Vertical patterning of plotted materials of Feature 2 in Trench 2 at 41LM50.**

scattered amongst the small burned rocks. Minimally 3 flakes and 1 burned rock were vertically orientated, which may indicate slight movement from shrink and swell processes in the clay sediment. Two washed edge-modified flakes (#71-11 and #71-14) from Feature 2 were also subjected to starch grain analysis. Neither specimen yielded any starch grains (Appendix D).

Two tiny pieces of charcoal (#71-7-1 and #71-7-2) were between the burned rocks and collected. Both wood charcoal samples (#71-7-1a and #71-7-2a) from 7 and 8 cmbs respectively, were radiocarbon dated. Sample #71-7-1a was identified as oak wood and yielded a  $\delta^{13}\text{C}$  (-25.7‰) corrected AMS date of  $180 \pm 40$  B.P. (UGA-14419). This charcoal is likely intrusive rather than originally associated with this prehistoric component. Sample #71-7-2a was not identifiable and yielded a  $\delta^{13}\text{C}$  (-25.8‰) corrected AMS date of  $330 \pm 70$  B.P. (UGA-14420). The date is more acceptable and provides an acceptable age for Feature 2 and the associated component (Table 9-1). This includes Feature 1 dated to ca. 330 to 430 B.P. and the associated cultural materials in the top 20 to 30 cm across this terrace. The charcoal date of  $330 \pm 70$  B.P is in general agreement with the projected date for the one Bonham and one Alba arrow point recovered from this component.

On the contrary, these charcoal dates are not supportive of the general age assigned to the Pedernales point base (#9-10) recovered *in situ* at 10 cmbs from just above Feature 1 or the non-feature associated Marcos point (#6-11) recovered from 0 to 10 cmbs in TU 9. These two dart points are interpreted as items collected/curated by later groups rather than representative of the age of the rest of the occupational materials.

A phytolith sample (#71-4) collected under a burned rock at 15 cmbs was analyzed. Again, it was anticipated that some plant food resources indicative of what was cooked by these burned rocks would be identified from this sample.

This presumably cultural sample was again compared with the presumed natural sediment sample (#41-4) from 18 cmbs in TU 6. Dr. Sudbury's procedures, results, and interpretations are presented in Appendix F. Feature 2 sample #71-4 yielded 24.2 percent cool season Pooids, 49.2 percent warm moist season Panicoids, and 26.7 percent hot dry season Chloridoids plus charcoal flecks (Appendix F). Burned short cell phytoliths account for 0.64 percent (1.5 cells) of the assemblage with 0.19 burned tree phytoliths. These data tend to indicate similarities with the modern sample from 41LM51. The natural sediment

**Table 9-1. Radiocarbon Data and Results from 41LM50.**

Cat. No.	Test Unit No.	Depth (cmbs)	Feature No.	Material Dated	Lab No.	Measured Age	13C/12C Ratio (‰)	Conventional Age (B.P.)	2 Sigma Calibration Range
1-2-1	1	0-10		Bone	UGA-14418	121.4 pMC	-22.66		
71-7-1a	NA	7	2	Charcoal	UGA-14419	190 ± 40	-25.7	180 ± 40	AD 1640-1960
71-7-2a	NA	8	2	Charcoal	UGA-14420	340 ± 70	-25.78	330 ± 70	AD 1400-1800
67-7	9	70-80		Charcoal	Beta-345274	940 ± 30	-24.4	950 ± 30	AD 1020-1160
66-7-1	9	67		Charcoal	Beta-345275	930 ± 30	-25.0	930 ± 30	AD 1020-1170
68-3-2	2	10-20	1	Burned Rock	Beta-345276	400 ± 30	-23.0	430 ± 30	AD 1430-1480
69-3-1a	2	22-23	1	Burned Rock	Beta-345277	300 ± 30	-23.0	330 ± 30	AD 1460-1650

**Table 9-2. Material Summary for 41LM50.**

Material Classes	Test Units									Test Unit Totals
	1	2	3	4	5	6	7	8	9	
Projectile Points	1	2							2	5
Stone Tools	3	5	10	2	4		3	2	9	38
Lithic Debitage	121	104	114	120	54	14	123	55	257	962
Mussel Shells	1	1	1						7	10
Charcoal (g)	127	114	128	126	63	20	133	65	284	1060
Feature Nos.	1							1		1
Burned Rocks	322	417	286	70	1769	14	405	363	60	3706
Bone Fragments	5	1	5				4			15
Snail Shells	1	2	7				3			13
<b>Totals</b>	<b>582</b>	<b>646</b>	<b>551</b>	<b>318</b>	<b>1890</b>	<b>48</b>	<b>671</b>	<b>486</b>	<b>619</b>	<b>5810</b>

sample (#41-4) indicates very hot summers, with enhanced spring and/or fall activity related to specific feature usage (Appendix F).

Based on the presence of multiple classes of cultural materials mixed together in no detectable or recognizable pattern, Feature 2 is interpreted as a dump/discard area. This discard occurred roughly between 300 and 400 B.P. based on one accepted charcoal date and the two burned rock residue dates, which support the age attributed to the associated Bonham and Alba arrow points.

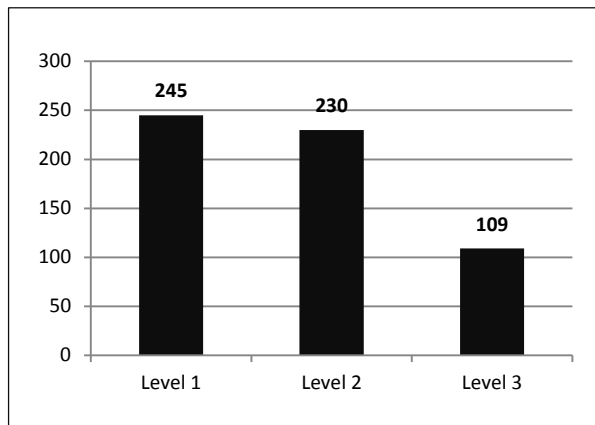
## 9.4 MATERIAL CLASSES AND FREQUENCIES

This section presents the classes and frequencies of cultural material recovered from this testing program at site 41LM50. This section includes not

only the item counts but also the horizontal patterning and density of materials per cubic meter. Not all the material was derived from a single cultural component, but one well-defined upper component and a potential lower component appeared vertically dispersed (see Section 9.5 below).

### 9.4.1 Lithic Debitage

The hand-excavations of 6.5 m<sup>3</sup> yielded a total of 962 pieces of lithic debitage. However, this class of material was unevenly distributed both horizontally and vertically, with TU 9 yielding high quantities and TU 6 low quantities relatively (Table 9-2). About 61 percent of the total debitage was from the top 30 cmbs and more concentrated than the remaining 37 percent that was widely dispersed throughout the lower 50 cmbs.



**Figure 9-9. Frequency by level for analyzed lithic debitage from 41LM50.**

The analyzed portion of the lithic debitage assemblage ( $N = 584$ ) was therefore judgmentally constrained to the top 30 cmbs (Figure 9-9), associated with the Late Prehistoric component. This group consisted of platform-bearing flakes, distal flake fragments (shatter/angular debris), and one core. The trends reported below are variables recorded as part of the TxDOT analysis Version 2.1 protocol for lithic debitage (TxDOT 2010). Non-Edwards chert comprised the largest group of raw lithic material, with 52 percent ( $N = 302$ ) of the analyzed lithic debitage.

Many non-Edwards specimens are fossiliferous or have inclusions (Figure 9-10), with material colors ranging from black to light tan. Subsets of non-Edwards materials included: quartzite (11 percent;  $N = 64$ ) (Figure 9-11), unidentified material (3 percent,  $N = 18$ ), chachedony (2 percent,  $N = 12$ ), and jasper (1 percent,  $N = 5$ ).

Twenty-nine percent ( $N = 167$ ) of the analyzed debitage was composed of one primary raw material, specifically, a grayish-tan Edwards Plateau chert. Within this general Edwards chert type, six sub-varieties were differentiated, based on different color combinations and characteristics.

These include Edwards cherts with; tiny dark dendrites, dark and light gray specks, white

inclusions, dark and light bands, banded with tiny dark spots, and some with no inclusions. It is probable that all these varieties were collected from local drainages and uplands.

The majority of the analyzed debitage ( $N = 404$ , 69 percent) falls between 6.4 and 12.8 mm size range (Figure 9-12). The second largest group is between 12.8 and 19.2 mm range group ( $N = 107$ , 18 percent); followed by those less than 6.4 mm size ( $N = 55$ , 9 percent). The larger sizes, those between 19.2 and 25.6 mm ( $N = 16$ , 3 percent) and greater than 25.6 mm ( $N = 2$ , less than 1 percent) are the least frequent. This high proportion of mid-size flakes indicates an emphasis on midstage reduction.

Thermal alteration of chert among platform-bearing flakes ( $N = 41$ , 14 percent) has a low representation (Figure 9-13). The most obvious thermal alteration occurs in the form of potlid marks (saucer shaped divots) and thermal breaks. These alterations indicate that heating occurred unintentionally, after discard.

Purposeful and/or intentional heating of raw material to improve quality for knapping would have involved removal from the heat source before such detrimental alterations could occur. Heat-alteration was observed on four pieces of finer-grained orthoquartzites. However, Edwards chert is very fine-grained material, quite suitable for knapping without heating.

The distribution of platform types is depicted in Figure 9-14. There are 277 (47 percent of total flakes) platform-bearing flakes in the analyzed assemblage. Of these, approximately 53 percent ( $N = 147$ ) exhibit multifaceted platforms (i.e., faceted). These flakes originate from more intensively modified objective pieces (e.g., bifaces or cores with prepared platforms). Flat striking platforms are the second most frequent type ( $N = 78$ ), representing 28 percent of the platform-bearing assemblage. Flat platform flakes





Figure 9-10. Sample of igneous/fossiliferous rock in archeological assemblage from 41LM50.



Figure 9-11. Sample of quartzite debitage in the archeological assemblage from 41LM50.

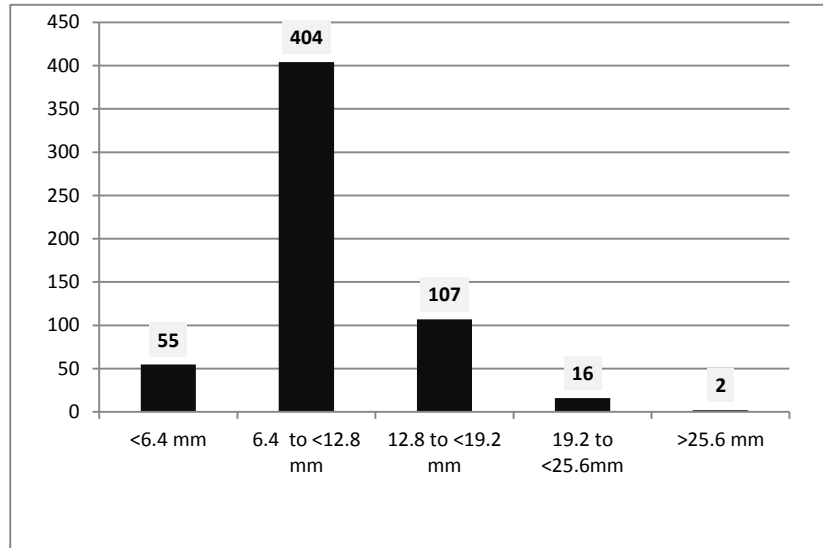


Figure 9-12. Size grade distribution of analyzed lithic debitage from Levels 1 through 3 at 41LM50.

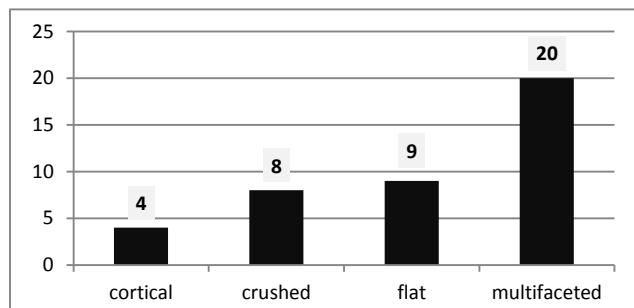


Figure 9-13. Distribution of platform-bearing flakes exhibiting thermal alteration.

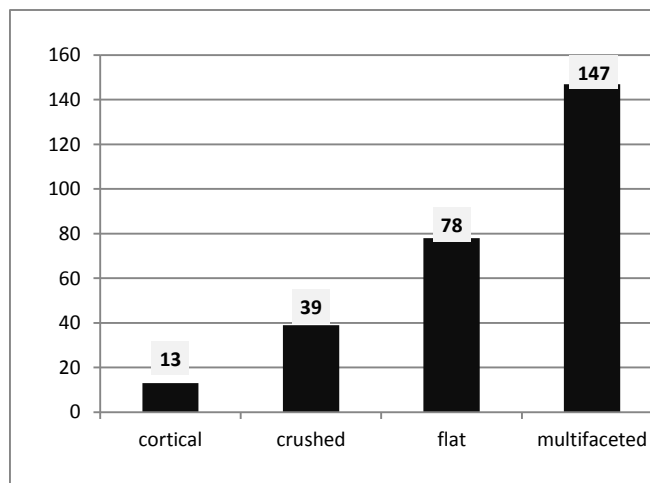
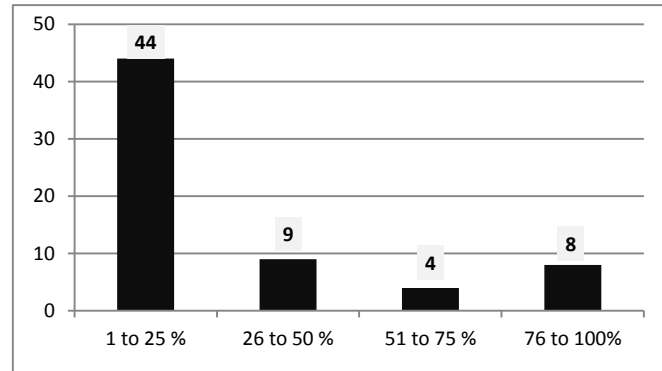


Figure 9-14. Frequency of platform types in the analyzed assemblage.





**Figure 9-15. Cortex present on analyzed platform-bearing lithic debitage from 41LM50.**

predominantly detach from nonbifacial tools or planar, unmodified core surfaces (Andrefsky 1998:94; Whittaker and Kaldahl 2001:54).

Crushed platforms comprise 14 percent ( $N = 39$ ) of the recognized platforms and are often created when hard-hammer percussion is used. Approximately 5 percent of platform-bearing flakes are cortical ( $N = 13$ ), that represent initial flake detachment from a cortex-covered objective piece (e.g., a rounded river cobble). This is a sizeable percentage, considering that cortical platforms are produced only in initial cobble reduction stage, which limits number of cortical flakes produced per cobble.

As with cortical platforms, lithic debitage that exhibits cortex on the dorsal face indicates early-stage reduction of objective pieces (Figure 9-15). A moderate proportion of platform-bearing flakes (23 percent,  $N = 65$ ) exhibit cortex. This supports the assertion that some initial reduction of raw material occurred on-site. Therefore, the knapping of raw material in the top three levels associated with the Late Prehistoric component appears to have included minor amounts of early-stage cobble reduction and midstage reduction.

The horizontal distribution of debitage by count and weight reveals higher concentrations were also present outside designated cultural features. These

features were concentrations of burned rocks representing two secondary dumps or discard locales, and four intact heating and/or cooking features. In addition to the analyzed flakes, the Late Prehistoric assemblage also contains a single lithic core fragment recovered from TU 2, Level 2. The core is Edwards chert, with multiple platforms, that indicate flake removal in multiple directions. Cortex was present on 25 to 50 percent of the outer surface.

#### 9.4.1.1 Summary of Analyzed Lithic Debitage

In summary, the lithic debitage from the top three levels, associated with the Late Prehistoric component, reveals clear procurement patterns of local Edwards and non-Edwards chert raw materials, as well as quartzite cobbles, reduction of cortex covered raw materials, bifacial tool and flake tool production. The moderate incidence of cortex on platform-bearing flakes indicates some on-site initial reduction of chert and quartzite cobbles. Cobbles from which this debris originated were most likely procured locally from uplands, or gravels associated with nearby streams such as Lynch Creek along the southern edge of the site.

The relatively restricted incidence of thermal alteration (14 percent,  $N = 41$ ) of platform-bearing flakes across lithics of various materials, including Edwards and non-Edwards chert, orthoquartzite, chalcedony, and jasper, combined with the presence

of heat spalls, indicates intentional heat treatment of materials (including the Edwards and non-Edwards chert) was not a necessary precursor to material reduction/use. The heat-altered debitage present likely represents discard into heating features, and does not appear that site occupants employed intentional heat treatment as a component of lithic reduction.

The large proportion of platform-bearing flakes with two or more facets (53 percent,  $N = 147$ ) indicates that bifacial thinning or midstage reduction were the primary sources of the flakes produced on-site. Core reduction at this component is indicated by the presence of a single lithic core (multidirectional) and platform-bearing flakes with only a single facet. Therefore, both bifacial tools and cores were reduced on-site, although what proportion of bifacial reduction flakes originated from bifacial cores as opposed to modification of large flakes cannot be determined through simple examination.

The frequency distribution of lithic debitage across the three levels analyzed shows a fairly uneven horizontal pattern of disposal near delineated feature boundaries (i.e., discarded burned rock concentrations). These apparent lithic concentrations are interpreted as reduction locale remnants and/or debris discard areas.

#### 9.4.2 Chipped Stone Tools

The hand-excavations of 6.5 m<sup>3</sup> yielded 48 chipped stone tools that include 5 projectile points with 2 identifiable and 1 unidentifiable arrow points, and 2 identifiable dart points. Other chipped stone tools consist of 1 untyped bifacial blade, 7 biface fragments, 3 scrapers, 1 uniface, and 32 edge-modified flakes. The density is equal to roughly a little over one tool for every 20 cm. The upper component in the top 30 cmbs yielded about 49 percent of the discernible tools. However, the possible lower component yielded about 37 percent of the tools.

One arrow point (#68-10) is classified as a Bonham point fragment (Figure 9-16). It exhibits a relatively long, straight stem and straight base, but both barbs are missing, as is the distal half. This arrow point exhibits a yellow UV response and is Edwards chert. The second is possibly an Alba point (#60-10) has a slightly expanding stem, squarish base, with large barbs protruding outward (Figure 9-16). It exhibits a dark UV response is not Edwards chert.

A third arrow point (#1-10) appears incomplete, as it is a poorly notched, crudely worked, and asymmetrical flake (Figure 9-16). This exhibits a light color UV response and is considered non-Edwards chert. It still exhibits the dulled

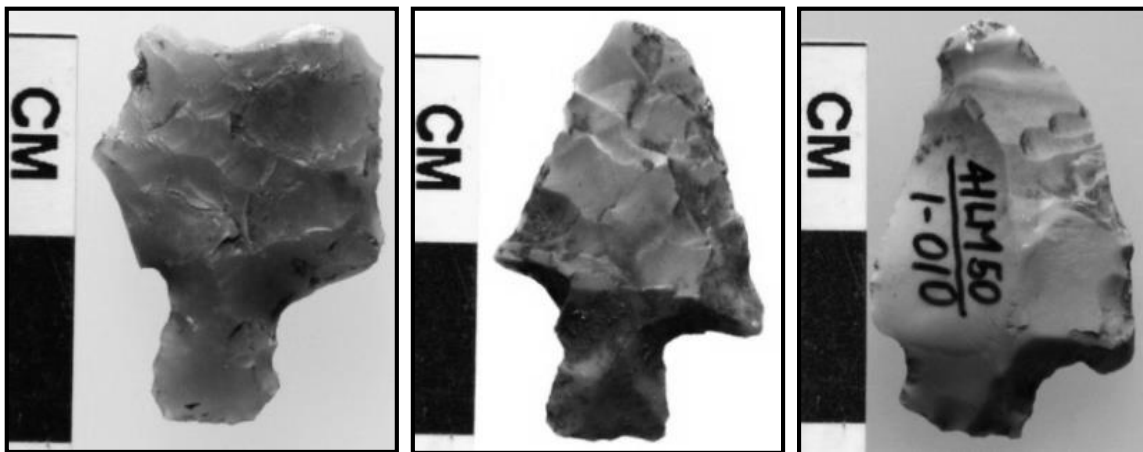


Figure 9-16. Arrow points; Bonham (#68-10), unwashed Alba (#60-10), and untyped (#1-10).

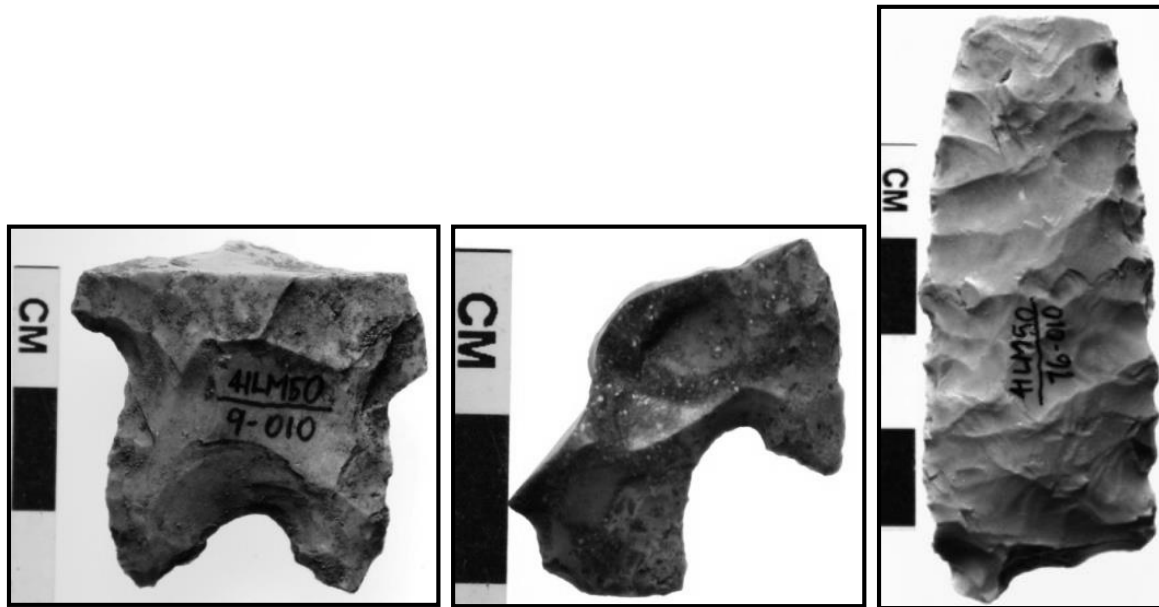


Figure 9-17. Pedernales (#9-10) & Marcos (#60-11) dart point fragments; untyped blade (#76-10).

bulb/platform at the distal end, neither face is worked, one face still exhibits the central ridge, and the other face reveals concentric stress lines. The notches are crudely done with one or two scars per notch that created an asymmetrical stem that is not worked. Only the Bonham point UV fluorescences a yellow similar to Edwards chert, whereas the other two arrow point fragments reveal a deep red color of unknown origin.

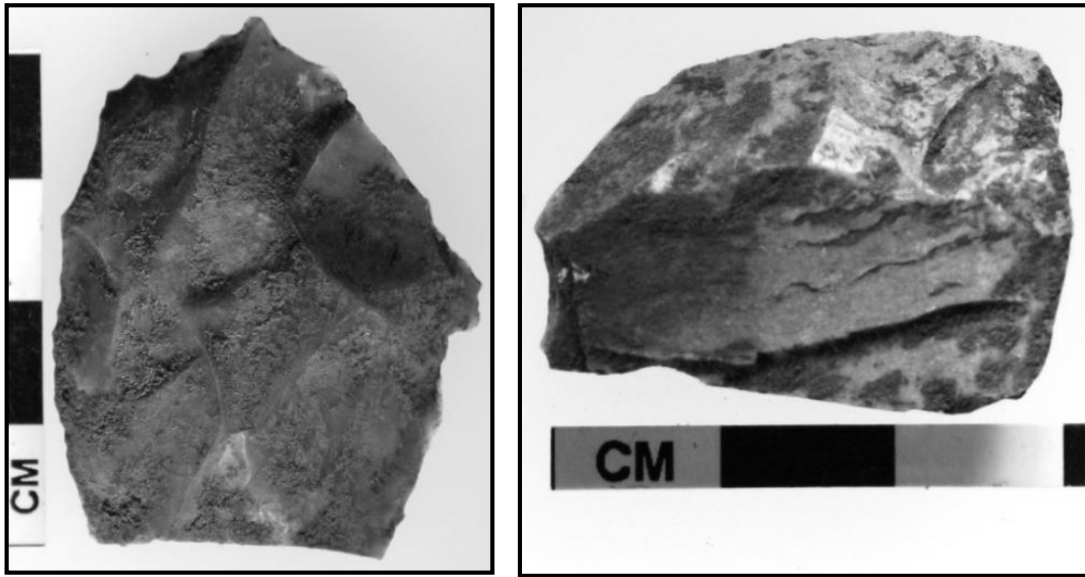
A base of a rather large Pedernales point (#9-10) was from 10 cmbs in TU 2 (Figure 9-17). The stem section has convex lateral edges with a deep concave base. A second dart point fragment (#60-11) is classified as a Marcos point as it exhibits one large corner-notch and barb with a convex base (see Figure 9-17). This piece is burned with pot lids removed from one face and breakage caused from extreme heat. The Marcos point was from 0 to 10 cmbs in TU 9. A rather long, well-made lanceolate blade (#76-10) that is relatively narrow with only one partial corner and part of a concave base remaining is currently untyped (see Figure 9-17). This piece maybe partially patinated. It was discovered in the backdirt of Trench 1. All three of

the later specimens have a yellow UV response and are considered Edwards cherts.

A single uniface (#18-11) was recovered from 10 to 20 cmbs in TU 3 (Figure 9-18). It exhibits a very crudely worked edge with one face that is covered with five or six major flake scars. This unwashed uniface was also subject to high-powered microscopic use-wear. Hardy observed residues that consisted of hair, wood, and possible starch grains along with soft polish all at the pointed end. He interpreted this tool to have served in multiple ways (Appendix C).

Three specimens were classified as scrapers and all are broken. Specimen #26-10 is a distal section with a steep, worked face that has a slightly rounded edge (see Figure 9-18). High-powered microscopic use-wear revealed hair and wood fibers, and soft polish across the worked face. It is interpreted to have functioned in scraping hides (Appendix C).

Specimen #48-10 exhibits a steep lateral edge on a broken flake. High-powered microscopic use-wear revealed no residues and only light polish across the worked face. It has an undetermined function



**Figure 9-18. Close-up of unwashed uniface (#18-11) and unwashed distal end of broken side scraper (#26-10).**

(Appendix C). Both Specimens #26-10 and #48-10 were in the top 30 cmbs in TUs 4 and 7, respectively. Specimen #14-10 exhibits limited edge-modification on a steep and an irregular shaped edge. This piece was recovered from 50 to 60 cmbs in TU 2. These three scrapers exhibit a dark red UV fluorescence that is unlike most Edwards cherts with their yellow UV response.

Seven specimens were classified as parts of bifaces. Two specimens (#59-10 and #66-10) were from the lower part of the excavations between 60 and 80 cmbs. The largest and most complete biface (#66-10) with only part of one proximal corner missing was from 62 cmbs in TU 9 (Figure 9-19). This large unwashed biface was subjected to high-powered microscopic use-wear analysis. Hardy observed wood fibers and raphides along with hard/high silica polish on parts of both faces. He interpreted the function to have been cutting wood/plant (Appendix C).

Specimen #59-10 might have been part of the distal end of a dart point. Neither Specimen #66-10 nor Specimen #59-10 reflects a yellow UV fluorescence similar to Edwards chert. The

remaining five fragments were recovered from 0 to 30 cmbs, manufactured of fine quality cherts, and represent small fragments of bifaces, primarily in the late-stage of production. All but Specimen #18-10 exhibit deep red UV fluorescence. The others exhibit no UV fluorescence or a dark purple color.

Two biface fragments (#54-10 and #71-10) were selected for high-powered microscopic use-wear analysis. Dr. Hardy's methods, results, and interpretations are presented in Appendix C with a brief summary presented here. Specimen #54-10 yielded hair and wood residues plus hard/high silica polish that Hardy interpreted to indicate this was used to scrape wood and hides. Specimen #71-10 yielded wood fibers and again hard/high silica polish that was interpreted from scraping wood (Appendix C).

Thirty-two specimens were classified as edge-modified pieces, which vary tremendously in overall size, shape, and material type. Twenty-four pieces (75 percent) were in the top 30 cmbs with approximately 8 percent a UV fluorescence yellow that represents Edwards chert. Only 23 percent have a yellow UV fluorescence to indicate Edwards

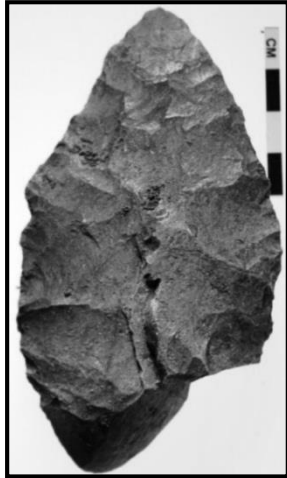


Figure 9-19. Large biface (#66-10) from lower questionable component.



Figure 9-20. Graver (#71-12) with worked tip (top left of picture).



Figure 9-21. Edge-modified flakes (#35-10 and #35-11) that yielded starch grains.

chert. Eight specimens reveal patterned scarred edges at relatively steep angles to indicate a likely scraping motion.

Specimen #61-10 exhibits multiple used/scarred edges with one lateral edge used sufficiently long to create a straight rounded edge on an igneous/fossiliferous rock. Minimally three specimens (#17-12, #19-10, and #35-10) have steeply worked edges as if used in a scraping motion. One specimen (#71-12) is a well-crafted graver (Figure 9-20) which came from within Feature 2. High-powered microscopic use-wear revealed no organic residues and only light polish. It was interpreted to have an unknown function (Appendix C).

Minimally three edge-modified flakes show evidence of having been burned and a number may have been heat-treated. Specimen #10-10 from 10 to 20 cmbs in TU 2 next to Feature 1 was burned and fractured from exposure to heat.

Seven specimens (#1-11, #2-10, #25-10, #35-10, #35-11, #71-11, and #71-14) were selected for starch grain analysis. Their results are summarized here with greater detailed data presented in Appendix D. Three yielded five starch grains plus one gelatinized grain. Specimens #2-10 and #35-11, both from 10 to 20 cmbs, yielded maize grains and the former also yielded two lenticular grains, likely little barley (*Hordeum pusillum*) or possibly wildrye (*Elymus* sp.), and a gelatinized grain (Figure 9-21). Specimen #35-10 from this same depth yielded one unknown starch grain. Although not in great quantities, the identification of these starch grains documents the use of these plants.

To complement the starch analysis seven edge-modified flakes were also subjected to high-powered microscopic use-wear analysis. A summary of the results is presented here with details of Dr. Hardy's methods, results, and interpretations in Appendix C. Hair and collagen fibers were observed on two specimens (#10-10 and

#10-11), wood fibers on two specimens (#12-10 and #61-10), plant fibers on at least four specimens (#12-10, #17-11, #25-10, and #61-10), and feathers on two (#53-10 and #17-11). Multiple edge-modified flakes reveal soft polish ( $N = 3$ ) with hard/high silica polish on others ( $N = 4$ ). These flakes probably served as multipurpose tools, scraping and cutting hides, scraping wood, and cutting birds (Appendix C).

### **9.4.3 Vertebrate Faunal Remains**

Test excavations yielded only 15 bone fragments that weigh cumulatively about 33 g, nearly all of which are unidentifiable. The 10 largest fragments were from 0 to 10 cmbs in TUs 1, 3 and 7, and include a nearly complete navicular cuboid (#46-2) of a whitetail deer, and several splintered long bone fragments. Three long bone fragments from TU 7 have whitish exterior cortex that may have resulted from sun bleaching. These pieces also lack root etching that is present on other fragments, likely reflecting they were not of the same age and more recent. In general, the long bone fragments have cortical wall thicknesses between 3.10 and 4.15 mm, within the range of deer elements.

One 1.5 cm long fragment (#21-2) of a thin-walled long bone, from 40 to 50 cmbs in TU 3, is lightly burned to a light gray to brown color. A small 1.0 cm long fragment from 60 to 70 cmbs in TU 1 is also lightly burned. Two partially burned fragments from lower in the profile indicate that if bone was not burned, there is limited chance for bone preservation in this context. A tooth enamel fragment from a bison-size large ungulate (approximately 24 mm in length, and 1.5 to 2.0 mm thick) at 20 to 30 cmbs in TU 2 was directly associated with Feature 2.

A single deer-size long bone (#1-2-1) that weighed 3.1 g from 0 to 10 cmbs in TU 1 was selected for radiocarbon dating since it might have been associated with the crudely made flake arrow point (#1-10). This bone fragment yielded a  $\delta^{13}\text{C}$  (-

22.6‰) corrected AMS date of 121.4 pMC (UGA-14418) or modern (see Table 9-1). The  $\delta^{13}\text{C}$  value derived from the dating process is reflective of an animal subsisting on  $\text{C}_3$  plants, and based on the thickness of the cortical wall, likely represents a deer in this instance. The results document that modern bones have become shallowly buried in the deposits, which created an apparent association with the prehistoric materials. Consequently, it is assumed that most recovered bone in the top 10 cm or so are not directly associated with the upper Late Prehistoric component. The lack of vertebrate remains is assumed to reflect poor preservation. Animal products were likely present as indicated by the hair and collagen residues observed on artifacts during use-wear analysis.

### **9.4.4 Mussel Shells**

The 6.5 m<sup>3</sup> hand-excavations yielded only 10 different mussel shell fragments, five of which have umbos still present with three more or less half valves. Shell #16-006 is a Tampico Pearlymussel (*Cyrtoniaias tampicoensis*), two (#20-006 and #63-006) are *Quadrula* sp., and one (#60-006-1) is a Threeridge (*Amblema plicata*). Shell pieces are quite small; the three more complete halves have diameters less than 2.5 cm. All have broken and/or weathered edges, and none exhibit identifiable cultural modification. Seven pieces were in the top 32 cmbs, with TU 9 yielding six pieces. Two pieces (#7-006 and #16-006) were from 69 to 80 cmbs with one shell from 30 to 40 cmbs. No shell pieces were present in Feature 1 or 2. The limited pieces recovered and their overall size indicates that mussels likely did not serve as food resources at this camp.

### **9.4.5 Charcoal**

Hand-excavations yielded very limited charcoal, with more pieces in the lower part of the profile. Seven samples were sent to Dr. Dering for identification (Appendix H). A couple of tiny flecks (#71-7-1 and #71-7-2) were recovered from

Feature 2. Sample #71-7-1 was identified as oak; the other sample was not identifiable. Three small, scattered chunks of charcoal (#66-7-1, #66-7-2 and #67-7-1) were collected from between 67 and 80 cmbs in TU 9, with one unidentifiable and the other identified as oak wood. A tiny chunk from 60 to 70 cmbs (#7-7-1) in TU 1 was identified as indeterminate hardwood. A piece of charcoal from 78 cmbs (#33-7-1) in TU 9 was not identifiable. Oak was apparently the primary wood selected for use in the fires regardless of temporal period. Sediment conditions have likely hindered preservation of potentially additional wood charcoal.

Two oak wood charcoal samples (#67-7-1 and #66-7-1), from 67 to 80 cmbs in TU 9 were sent for radiocarbon dating. Sample #66-7-1 yielded a  $\delta^{13}\text{C}$  (-25.0‰) corrected AMS date of  $930 \pm 30$  B.P. (Beta-345275; see Table 9-1). Sample #66-7-1 yielded a  $\delta^{13}\text{C}$  (-24.4‰) corrected AMS date of  $950 \pm 30$  B.P. (Beta-345274).

A natural tree burn about 2 m or so northwest of Feature 2 in Trench 2 was observed, and a charcoal control sample (#75-7) from 38 cmbs was collected, but not dated or identified. Considerable red oxidized sediment was observed around the burned stump. It is unknown if this tree burn contributed charcoal to Feature 2.

#### 9.4.6 Ground Stone Tools

A large (2,381 g) piece of sandstone (#27-10) collected as a burned rock from TU 4, at a depth of 20 cmbs, under closer examination revealed limited macroscopic use-wear on part of one corner of one surface (Figure 9-22). This is a triangular shaped piece with two broken edges and one natural outer edge. That area towards what is projected to have been the middle of the rock, at the junction of the two broken edges, reveals some smoothing in a shallow 4.5 mm deep basin over an  $25 \text{ cm}^2$  area

with an outer band about 5 cm wide of what appear as small peck marks along the outer margin of the smoothed area towards the one in tacked margin of the rock.

The apparent peck marks are not all the same shape or size. Most marks are 3 to 5 mm wide and roughly 1 to 2 mm deep. The opposite face reveals no cultural alterations and appears water worn.

This metate fragment is roughly 21 cm long by 14 cm wide and 5 to 6 cm thick. The worked surface unfortunately has suffered several recent impact marks from shovel damage and one freshly broken edge.

The broken edge reveals a grainy, reddish color (top edge is a yellowish-red 5YR 4/6), whereas the middle is a light yellowish-brown (10YR 6/4) and likely heat altered. It is possible that this piece originally served as a metate, but was later used as a heating rock. This entire piece was sent for starch grain analysis. Dr. Perry recovered only a single unidentifiable gelatinized starch grain (Appendix D). Whatever was cooked it was done with heat and water present.



**Figure 9-22. Top view of broken metate (#27-10).** Note: The upper left corner (darker area) shows a ground surface next to pecked zone below that. Bottom edge is the natural rock edge

#### 9.4.7 Snail Shells

Roughly 15 snail shells were collected and only a few others were observed in the field. These shells represent minimally three types that include small *Helicinidae* shells and only a single *Rabdotus* shell. Roughly 85 percent were in the top 20 cmbs and are potentially modern. Snail shells were not recovered from in or around either burned rock feature. No *Rabdotus* shells were observed in the trenches.

#### 9.4.8 Burned Rocks

Hand-excavations of 6.5 m<sup>3</sup> yielded 3,638 burned rocks that weighed 88,261.4 g cumulatively, or about 24 g per rock. Most were limestone pieces with a few reddish sandstone and few unknown pieces. Burned rocks were very difficult to distinguish from natural rocks as many of the limestone pieces were not broken and had water rounded edges. The colluvial slope immediately behind the site contributed gray, rounded limestone pieces to the alluvial deposits. The cutbank immediately upstream also exhibited a thick zone of small to medium size, weathered, rounded limestone pieces that were also in alluvial deposits. Most burned rocks from Features 1 and 2 revealed similar rounded and weathered unbroken limestone pieces. This caused considerable uncertainty as to what constituted burned rock. A few burned rocks are small chunks of sandstone that are reddish in color, the same as the natural sandstone in the area. With the difficulty in distinguishing burned rocks, many of the smallest pieces (those less than 4 cm in diameter) of what was called burned rock in the field may not actually have been burned rocks. Therefore, the frequency of burned rocks provided is likely inflated. The high frequency identified in TU 5, the test unit closest to the colluvial deposits at the base of the bedrock slope, consisted mostly of small rounded gravelly-looking material that most likely was not burned rock (Table 9-3). The counts from TU 5 are significantly higher than those from any other test unit. For these reasons the

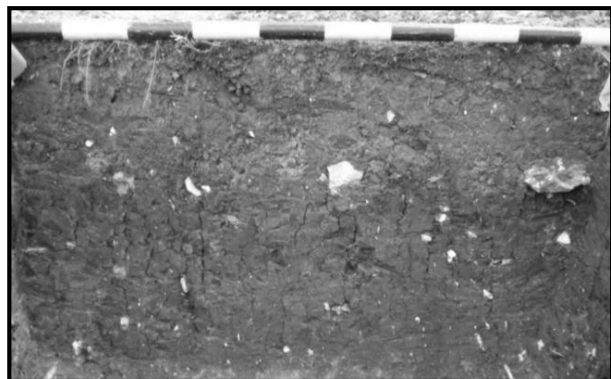
counts from TU 5 are not considered in the following discussions.

### 9.5 CULTURAL STRATIGRAPHY AND VERTICAL DISTRIBUTION OF ARTIFACTS

This section focuses on the vertical distribution of the cultural materials within the brown/dark brown (10YR hue) clayey, very thick (at least 80 cm) cumulic A horizon that developed in these alluvial deposits (Figure 9-23). No cultural materials were observed on the surface and the buried material was unevenly distributed horizontally and vertically.

Cultural materials began just below the surface to roughly 80 cmbs (Tables 9-3 and 9-4). Discounting TU 5 counts of burned rocks ( $N = 1,769$ ) as they are questionable as discussed above, the highest frequency (30 percent) of burned rocks was between 10 and 20 cmbs ( $N = 558$ ) with levels directly above and below containing relatively high frequencies at 19.5 percent ( $N = 365$ ) and 14.3 percent ( $N = 268$ ), respectively.

Therefore, nearly 64 percent of the burned rocks were recovered from the top 30 cm, which also included burned rock Features 1 and 2. A noticeable drop in burned rock counts occurred below about 25 cmbs, with the next light scatter of burned rocks



**Figure 9-23. South wall profile of TU 7 that reveal cultural rocks in clay loam sediments.**

Note: The white spots are small pieces of limestone.



**Table 9-3. Vertical and Horizontal Distribution of Burned Rocks at 41LM50.**

Depth (cmbs)	Test Units									Totals
	1	2	3	4	5	6	7	8	9	
0-10	24	59	67	13	107	1	43	124	34	472
10-20	46	97	98	34	415	6	157	94	26	973
20-30	46	44	35	20	325	7	77	39	none	593
30-40	42	41	32	3	420	none	41	15	none	594
40-50	47	31	18	none	204	none	32	44	none	376
50-60	62	44	6	none	154	none	55	29	none	350
60-70	52	18	22	none				18	none	110
70-80	3	15	8	none				none	none	26
Totals	322	349	286	70	1769	14	405	363	60	3638

**Table 9-4. Vertical and Horizontal Distribution of Lithic Debitage at 41LM50.**

Depth (cmbs)	Test Units									Totals
	1	2	3	4	5	6	7	8	9	
0-10	10	21	27	2	7		26	29	126	248
10-20	32	22	20	16	29	4	64	12	40	239
20-30	10	5	13	19	12	4	22	4	28	117
30-40	23	6	6	14	4	2	4	1	23	83
40-50	12	13	10	22	1	1	3	3	14	79
50-60	13	16	7	15	1	3	4	4	6	69
60-70	11	9	18	12				2	16	68
70-80	10	12	13	20					4	59
Totals	121	106	114	120	54	14	123	55	257	964

under Feature 1, at roughly 33 to 38 cmbs. In the lower 50 cm (30 to 80 cmbs) the nature of the rounded pieces of limestone created uncertainty as to what actually constituted burned rocks.

The highest frequencies of lithic debitage, about 50 percent of the total, were in the top 20 cmbs. The frequency dropped to about half that average between 20 and 30 cmbs. Figures 9-24 through 9-26 reveal the general vertical frequency of the piece-plotted burned rocks and flakes plus the lithic counts per level for four selected test units. As just discussed, the two recognized burned rock features (Features 1 and 2) were in the top 20 cmbs, plus a relatively high density of burned rocks was in the top 30 cmbs. This concentration of cultural material defines the presence of a component in the top 30

cmbs. This component is assigned to the Late Prehistoric period based on the presence of two identifiable arrow points – an Alba (#6-10) and a Bonham point (#68-10), plus one untyped roughly crafted notched flake/preform (#1-10) in the gross shape of an arrow point.

However, two dart point fragments, a Pedernales base (at 10 cmbs) and a burned Marcos point fragment were also in the upper 30 cmbs. About 63 percent of the lithic debitage recovered, and 71 percent of the stone tools were part of this same component. About 87 percent of the sparse bones appeared in this upper 30 cmbs, but most bones appear modern based on the modern date obtained from one bone.

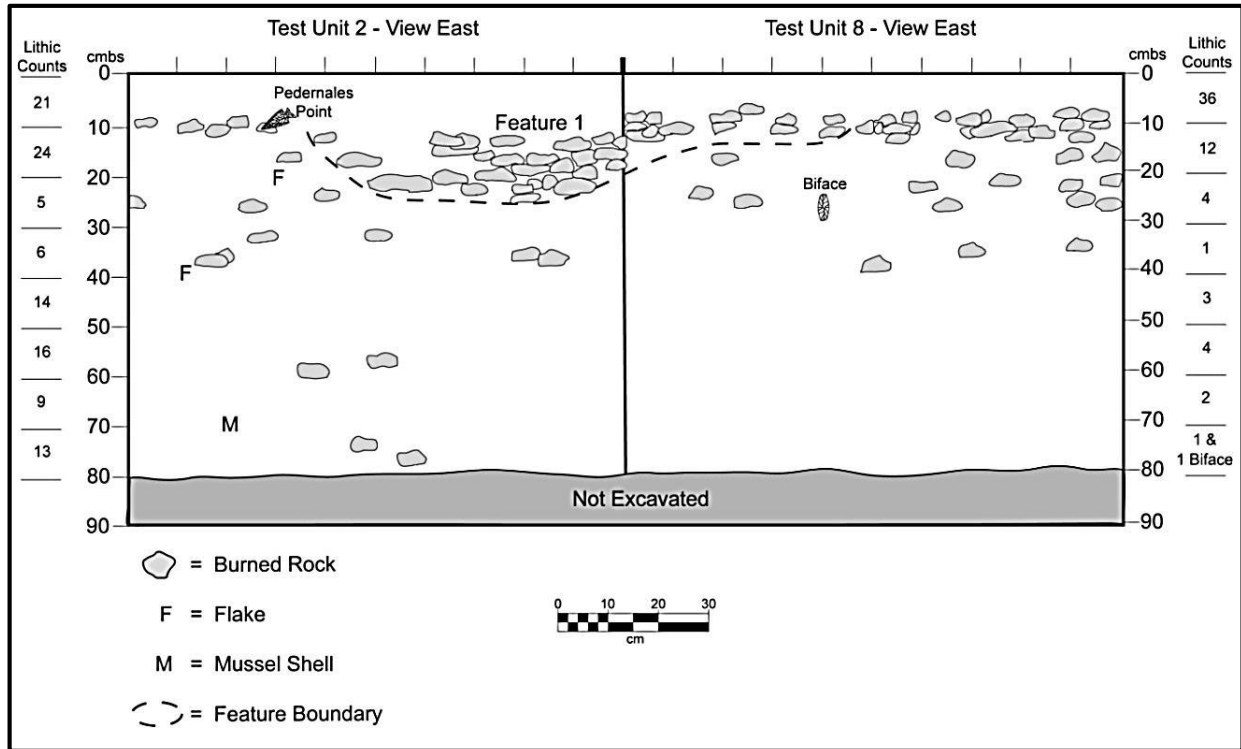


Figure 9-24. Vertical patterning of plotted materials in TUs 2 and 8 at 41LM50.

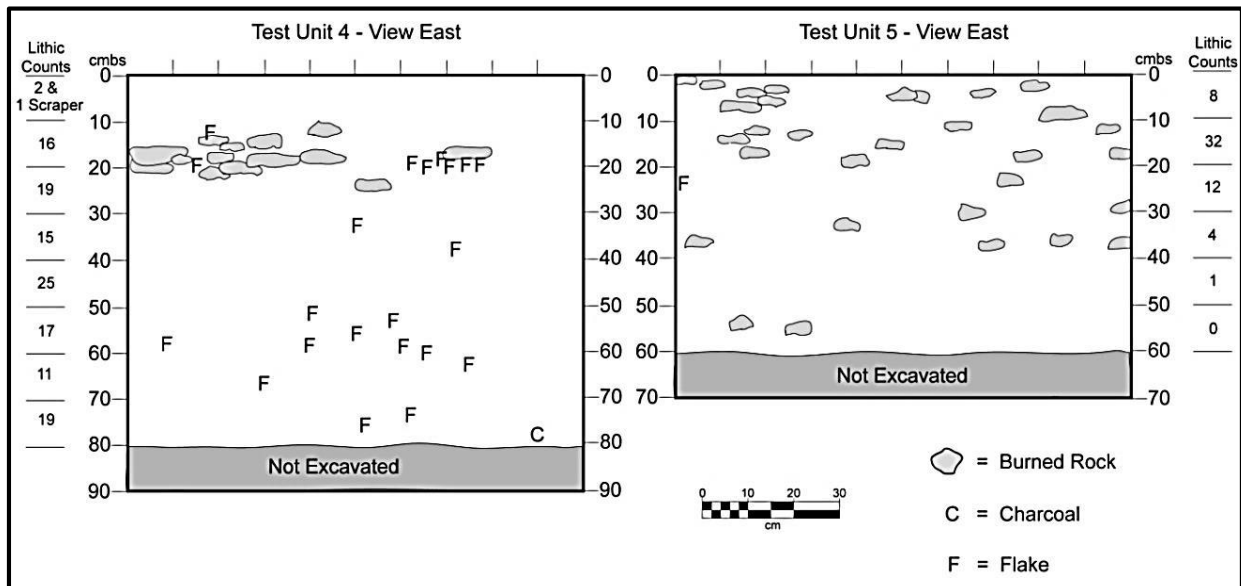
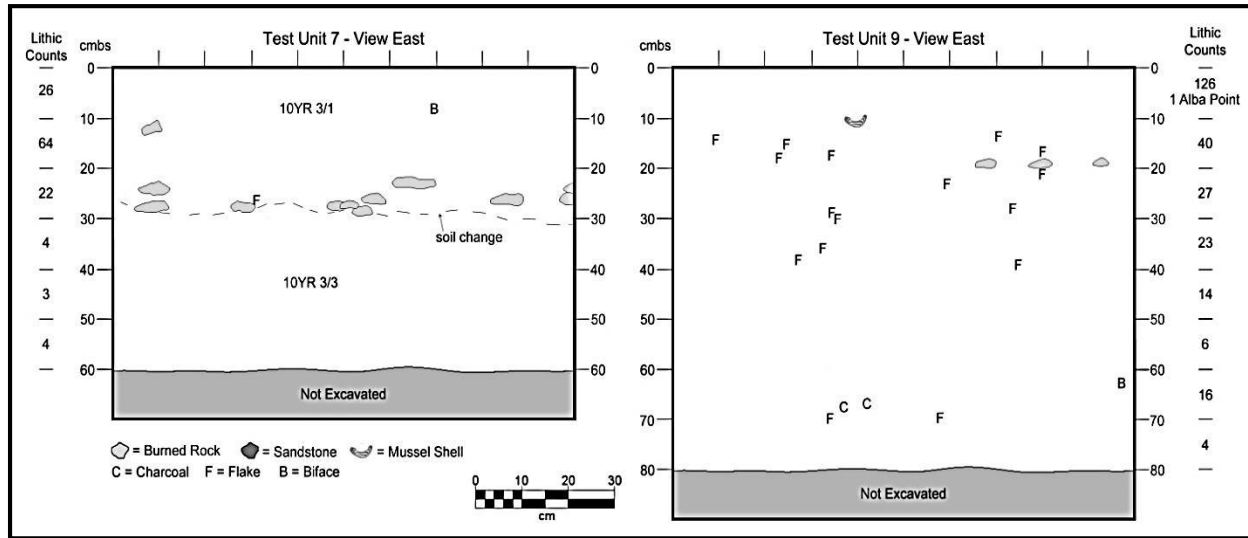


Figure 9-25. Vertical patterning of plotted materials in TUs 4 and 5 at 41LM50.



**Figure 9-26. Vertical patterning of plotted materials in TUs 7 and 9 at 41LM50.**

The two charcoal radiocarbon dates from Feature 2 and two burned rock residue dates from Feature 1 yielded dates within the last ca. 400 years (see Table 9-1) and indicate the approximate age of this upper Late Prehistoric component. Therefore, the two dart point fragments are interpreted as items collected by later populations or displaced artifacts, rather than representative of the time of occupation. The Pedernales point from 10 cmbs in TU 2 was slightly higher in the profile than the two arrow points. The thick cumulic A horizon is comprised mostly of clay with the potential for shrink and swell actions, which create conditions that might have vertically displaced small artifacts over time.

Below 30 cmbs, the lithic debitage counts per 10 cm level decreased with depth and vary between 83 and 59, with the lowest counts in the lowest levels. In the lower part of the excavations, other classes of cultural material, such as burned rocks, vertebrate faunal remains, and formal tools were not only sparse but scattered. No diagnostic projectile points indicate a separate and distinct occupation or component.

The scattered lithic debitage and sparse burned rocks below 30 cmbs indicates that cultural events likely occurred, but are not well-defined nor easily discernible. It is possible that a lower component is

present between 40 and 80 cmbs, but it is not well-represented by any materials other than scattered lithic debitage. Several flakes throughout the profile were vertically orientated when discovered, which indicates some movement and/or vertical displacement of small items has occurred. It is unclear how much of the upper materials may be filtering downward in the profile.

Vertically dispersed cultural materials below 30 cmbs include 18 percent of the stone tools and nearly 20 percent of the lithic debitage. Two mussel shell fragments and one tiny burned bone fragment were also in these lower deposits. A large medial section of a lightly patinated unidentifiable dart point, recovered from the backdirt of Trench 1, also hints at the presence of an earlier, possibly Archaic component. However, the possible lower component is not vertically well-defined, lacked diagnostic tools and features, and yielded few burned rocks. The two oak wood charcoal samples from between 67 and 80 cmbs in TU 9 that yielded dates of 930 and 950 B.P., which likely date this potential lower component.

One edge-modified lithic (#61-12) from 10 to 20 cmbs in TU 9 is of the same unique, high-quality chert as Specimen #22-10 from 50 to 60 cmbs in

TU 3, and Specimen #67-10 from 70 to 80 cmbs in TU 9. Presumably, the occupants from the upper Late Prehistoric component might have accessed the same raw material types/sources over a long time span as indicated from the raw materials present in the possible lower component. However, this uncommon chert type could also potentially reflect significant downward vertical displacement, if these pieces were from the same parent rock or procurement activity of the upper component.

### **9.5.1 Geoaarcheological Context**

The deposits in Trenches 1 and 2 revealed a single, black (10YR 2/1) silty clay to clayey Holocene alluvial fill with an A-AB-Bk soil profile with a stage II calcic horizon. The top 80 cmbs, the A and AB horizons, appeared cumulic, and all of the cultural material recovered from this site was found partially stratified within these soil horizons. The north end of this T<sub>2</sub> terrace surface terminates at bedrock upland, and it is likely that there is a small but significant amount of coarse colluvial material interbedded with the alluvium at the north end of this site.

Two zones of material were observed in Trench 1 profiles, at approximately 10 and 65 cmbs, respectively. Three zones were noted in Trench 2 at depths of 8 cmbs, 25 cmbs, and 65 to 70 cmbs. The lowest zone, radiocarbon dated by two charcoal samples to around 930 and 950 B.P. likely represent this widely dispersed material, whereas the uppermost Late Prehistoric component was a fairly dense surface littered with burned rock, some of which almost resembled a pavement. This Late Prehistoric component dates to between 330 and 430 B.P. The prehistoric cultural material appears relatively discrete, and isolable, but the height of the surface and early Holocene (or older) age of the core of the deposit indicates that the sedimentation rate on this surface during the middle to late Holocene was probably low. Some evidence exists in the form of pressure faces, a few slickensides, and vertically oriented dark streaks at the top of the

Bk horizon (presumed crack fills) indicate some vertic tendencies to this soil, but that said, the consistent depths of the apparent cultural material indicates that there has not been a tremendous amount of vertical mobility within this deposit. However, poor charcoal preservation within the Late Prehistoric component may indicate the shrink-swell tendencies may be significant as some soil features imply.

The natural sediment sample (#69-4) from 18 cmbs yielded 21.3 percent cool season Pooids, 42.8 percent warm moist season Panicoids, and 35.9 percent hot dry season Chloridoids. In comparison to the modern sediment sample (#157-4) results from 41LM51 data indicates very hot summers, with enhanced spring and/or fall activity related to specific occupation. The Late Prehistoric environmental sample was apparently much hotter than modern times with less cool season change and more aridity in the summer (Appendix F). If the vertic tendencies in the soil profile were significant, which at this stage is unclear, or wide spread, this may affect the reliability of the phytolith record.

## **9.6 SUMMARY, CONCLUSIONS, AND DISCUSSION**

### **9.6.1 Summary**

TxDOT planned to replace the current bridge over Lynch Creek East along FM 580W. The bridge replacement would require a temporary easement on the southernmost right-of-way, west of the current bridge, for a temporary low-water crossing. The proposed easement would impact a 6 m tall T<sub>2</sub> terrace that continues westward from the current bridge for at least 20 m. Cultural materials were discovered in the T<sub>2</sub> terrace within the proposed easement.

TRC archeologists recorded and mapped the APE, mechanically excavated two deep trenches at the western margin of the proposed easement, and

hand-excavated nine 1-by-1 m test units totaling 6.5 m<sup>3</sup> across the easement to assess the NRHP and SAL eligibility of that part of prehistoric site 41LM50 within the proposed easement. This investigation focused on a linear section of 41LM50 within the proposed roughly 10 m wide by roughly 50 m long segment of the temporary easement that will parallel the existing right-of-way on the north side of the creek and west of the bridge.

At this newly documented prehistoric site, buried cultural materials were encountered between 5 and 80 cmbs, with the majority of cultural materials within the top 30 cm, especially the burned rocks and lithic debitage. The cultural materials recovered from 5 cmbs to roughly 30 cmbs constitute a buried, relatively well-defined Late Prehistoric component that yielded two diagnostic arrow points (an Alba and a Bonham), 31 informal and formal chipped stone tools, at least two burned rock discard features, sparse fragmented mussel shells, and 584 pieces of lithic debitage. Two wood charcoal dates of 180 and 330 B.P. were derived from Feature 2. Two dates on organic residues from inside two burned rocks from Feature 1 yielded dates of 330 B.P. and 430 B.P. These four dates document this Late Prehistoric event to within the last 450 years. The charcoal date of 180 B.P. is likely from intrusive charcoal not directly associated with this prehistoric component. No artifacts of the Protohistoric period were recovered to indicate an event of that period, but encountering obvious Protohistoric materials is a rare occurrence, and the 6.5 m<sup>3</sup> area investigated is a small sample.

The horizontal distribution of the different material classes is indicative of the presence of multiple localized activity areas. The absence of pottery at this late component is surprising, as is the absence of vertebrate faunal remains. The latter may be a reflection of poor preservation, or the absence of fresh meat resources, or an abundance of seasonally available plant resources. The artifacts represent a restricted time period, and their context is relatively

good, with only minor apparent movement of a few small items. Within this young component, two collected/curated Late Archaic dart point fragments (one Pedernales and one Marcos; Collins 1995, 2004) were present. A few modern animal bones (deer-size) were mixed in the top 10 cmbs just above most Late Prehistoric materials, as one bone from the top 10 cmbs yielded a modern radiocarbon date.

The absence of macrobotanical and faunal remains hinders our understanding of the subsistence practices at this Late Prehistoric component, but starch grain analysis provides some insight, through the identification of maize starch on two tools and two burned rocks, plus some grass starch as well.

A deeper, and possibly earlier more dispersed cultural component below the Late Prehistoric component was detected between roughly 40 and 80 cmbs. Scattered lithic debitage, scattered burned rocks, and the occasional stone tool (7 edge-modified flakes, 1 biface, and 1 scraper) may represent a dispersed lower component. No diagnostic artifacts or features were encountered within this roughly 40 cm thick zone. Two isolated wood charcoal chunks from 67 to 80 cmbs yielded radiocarbon dates of 930 B.P. and 950 B.P., and may document the age of these scattered materials. Our understanding of this deeper cultural material was limited due to the lack of encountered features and diagnostic projectiles, as well as the vertically dispersed nature of the debitage.

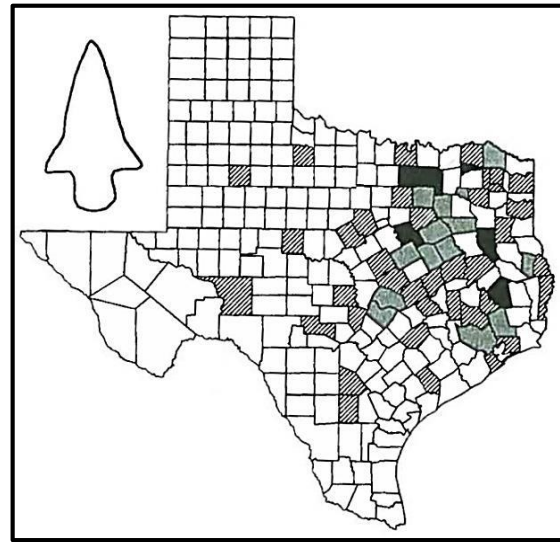
## 9.6.2 Conclusions and Discussion

A portion of prehistoric site 41LM50 was revealed within the tested T<sub>2</sub> terrace in the proposed temporary easement. This eligibility assessment of 6.5 m<sup>3</sup> of the top 80 cmbs of the thick, cumulic A and AB horizons developed in the Holocene alluvial deposit, contains minimally one well-defined Late Prehistoric component in the upper 30 cmbs, and possibly additional poorly defined dispersed component(s) between 40 and 80 cmbs.

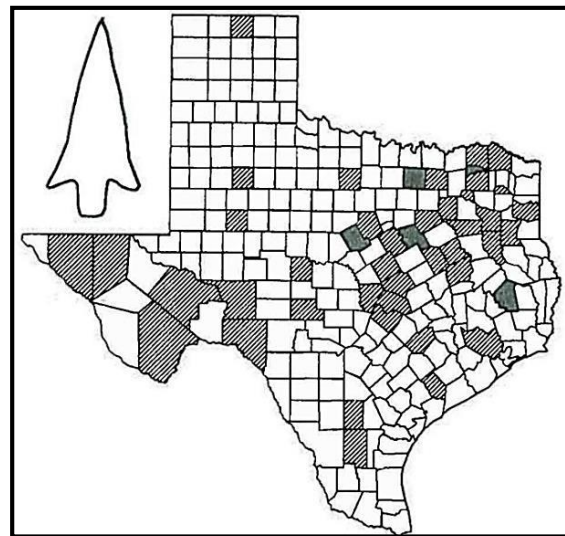
The possible lower component is quite sparse and lacks diagnostic artifacts and features, and therefore is not discussed further below.

This investigation revealed one of the few isolated Late Prehistoric components that have yielded Bonham and Alba arrow point types apparently unassociated/unmixed with Perdiz arrow points in the greater central Texas region. The Perdiz point type is the most common arrow point type of the central Texas region during the latter part of the Late Prehistoric period. In his review of the central Texas cultural history, Collins (1995, 2004) lists sites that have yielded Perdiz points and Scallorn/Edwards points for the Late Prehistoric period, but does not mention other arrow point types or phases/intervals for this period. This follows Prewitt's (1981) central Texas chronology, where he discusses only the Austin and Toyah phases for this Late Prehistoric period (following Jelks 1962), neither of which are based on the Alba or Bonham point types.

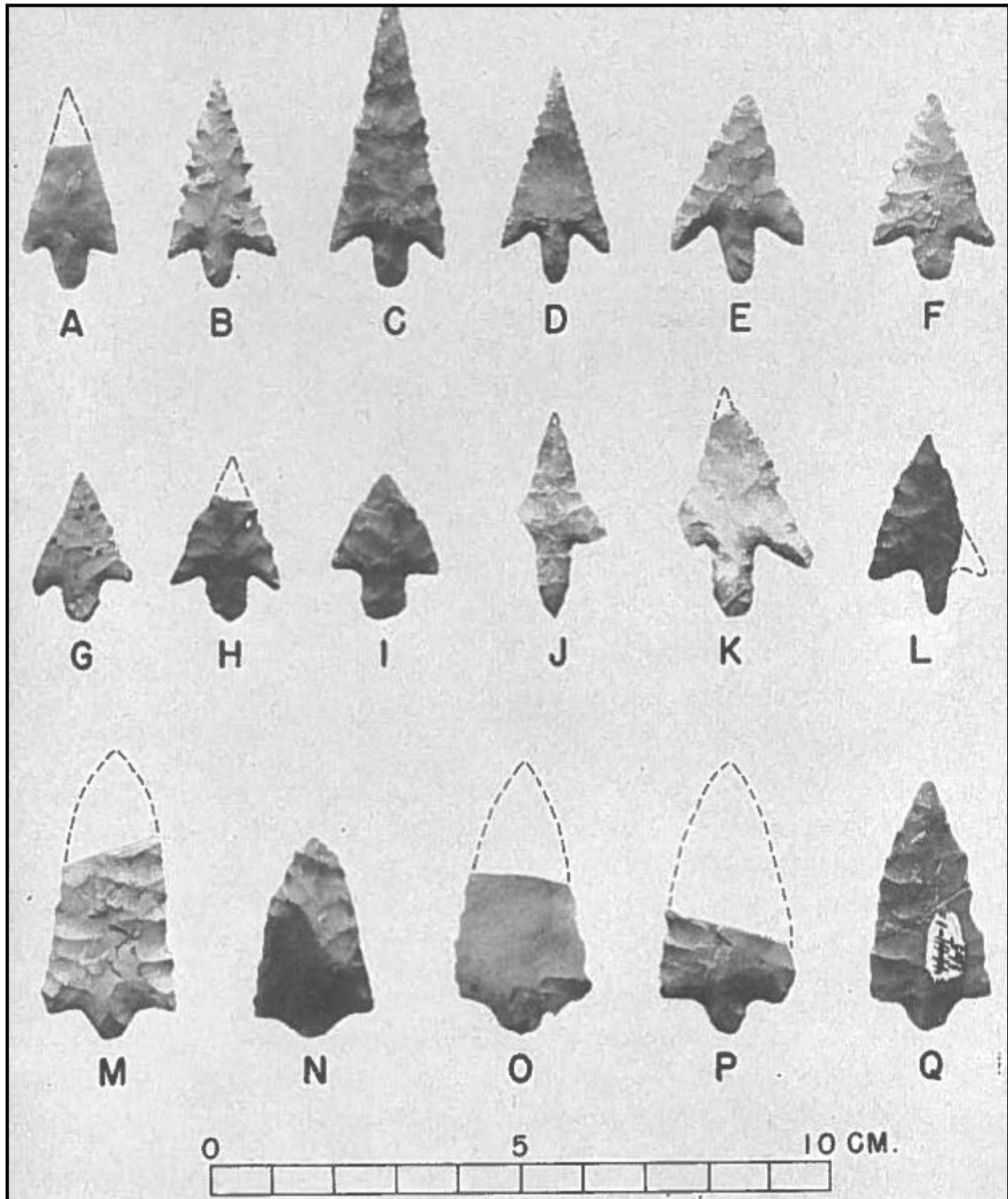
Turner et al. (2011:177) indicate both the Alba and Bonham are Late Prehistoric projectile point types. They depict the Alba type occurring predominately in the eastern third of Texas. The Bonham type overlaps the distribution of the Alba, and extends slightly further south into central Texas (2011:180). Prewitt (1995:89) also shows the Alba point across most of the eastern third of Texas, with other occurrences scattered in central and southern Texas (Figure 9-27). Prewitt (1995) shows that the Bonham point type occurs across much of the northeastern corner of Texas, but also scattered across central and extreme western Texas (Figure 9-28). Both Prewitt's maps depict Alba and Bonham points in counties immediately north and east of Lampasas County, but not in Lampasas County itself. Although these two point types obviously occur in central Texas (e.g., Travis, Williamson, and Bell Counties), limited research has been conducted concerning patterns of occurrence and relationship between these two



**Figure 9-27. Prewitt's (1995:89) distribution map of the Alba points in Texas.** Note: The black counties have over 50 points, gray counties have between 11 and 50 points, and diagonally lined counties have 1 to 11 points.



**Figure 9-28. Prewitt's (1995:93) distribution map of the Bonham points in Texas.** Note: gray counties have between 11 and 50 points, and diagonally lined counties have 1 to 11 points.



**Figure 9-29.** “Toyah Focus” arrow point types. Note: A-F Perdiz whitney; G-I Perdiz morgan; J-L miscellaneous Perdiz; M-Q Clifton (Jelks 1962:25, Figure 12).



types in various contexts, or if they indicate separate cultural issues in identification of the different arrow point types, such as manifestations. Some problems stem from typological misidentifications of arrow points, and names that have been previously associated with certain forms that have changed over time (i.e., see types listed for the Kyle site in Jelks 1962) and the wider issues of typology itself. For example, some 'Toyah Focus' arrow points from the Hill County Kyle site (41HI1) typed as Perdiz show stems that are relatively wide, with only minor tapering, and are divided into subgroups such as 'Perdiz whitney, Perdiz morgan' and miscellaneous based on stem differences (Figure 9-29; Jelks 1962:25, Figure 12). These different stem forms have characteristics similar to Bonham and Alba forms (i.e., Turner et al. 2011). Even some subdivisions shown in the Scallorn type from the Kyle site (see Jelks 1962, Figure 13) might also be classified in the Alba-Bonham groups.

Little is known about what community groups employed Bonham and Alba arrow point types; if these points perhaps reflect the presence of a separate cultural manifestation, and what relationship they have with the Perdiz-using Toyah groups of central Texas. Sometimes Alba-Bonham types occur in very low frequencies within Toyah components (e.g., San Felipe Springs, Mehalchick et al. 1999; Analysis Unit 1 at the Baylor site [41ML35], Mehalchick and Kibler 2008), which may indicate some type of contact and/or exchange between groups.

Alba, Perdiz, and Scallorn arrow points occurred together in Analysis Units 1 and 2 at the J. B. White (41MM341) site along the eastern boundary of the Blackland Prairies, but in contrasting frequencies (Gadus et al. 2006:139). Analysis Unit 1 included 30 projectiles: Alba points dominant at 43 percent, followed by Scallorn at 30 percent, and Perdiz at 23 percent. Analysis Unit 1 was radiocarbon dated by 11 samples to between 720 and 970 B.P. (cal A.D.

1010 to 1380, 1-sigma). Analysis Unit 2 included: 3 Alba, 1 Perdiz, 12 Scallorn, and 1 Darl. Analysis Unit 2 was dated by 12 samples to between 860 and 1190 B.P. (cal A.D. 895 to 1250, 1-sigma). Neither Analyses Units 1 nor 2 yielded a sizeable ceramic assemblage, as only 4 plain sherds (3 bone-tempered and 1 sandy paste) were recovered from the data recovery excavations. Perttula (2001:124-125) analyzed 13 ceramic sherds from the testing phase, and suggests a Caddoan connection, based on the grog tempering and a carinated bowl form. Caddoan ceramics from the northeastern part of the state are present in a few Toyah component sites in central Texas (i.e., Jelks 1962; Ricklis 1994; Perttula et al. 2003). The mechanism by which these ceramic artifacts entered the region is still unknown. The pottery, unlike the projectile points, is often very distinctive in surface finish and temper characteristics, and is potentially traceable to the regions of manufacture (e.g., Perttula et al. 2003; Reese-Taylor et al. 1994).

Shafer (1973:199-202) defined subgroups of Alba points within 28 points recovered from Cluster 1 in Feature 161 at the George C. Davis site (41CE19) in Cherokee County. These subdivisions were based on variations in form, mostly on the stem edge/base. These subgroups were reinterpreted by Gadus et al. (2006:100) into four general form groups: bulbar; straight/straight; straight/rounded; and straight/concave stem edge/base forms. This indicates a range of variability within the Alba type that possibly has resulted in differential typological assignment by some researchers. Many of the 14 Alba points illustrated by Gadus et al. (2006:92, Figure 7-2) appear nearly identical to what Turner et al. (2011:180) illustrate as Bonham points. Confusion exists even amongst researchers as to the correct typological assignment/classification of these Late Prehistoric arrow points.

Recently, Carpenter (2012) examined, evaluated, synthesized, and revised previous Toyah models (see Johnson 1994; Arnn 2012b; Kenmotsu and



Boyd 2012). In his research, Carpenter (2012) examines the Toyah identity, considered the various archeological manifestations (i.e., Cielo, Caddo, Plains Village, and Rockport) across the region, and then presents his revised Toyah model, supported by evidence from archeological and historical records. Carpenter (2012) sees the emergence of Toyah sometime between circa A.D. 1000 and 1300 in the Waco region, about the same time as Shafer (2006) theorizes the presence of the Prairie Caddo. He also postulates this as approximately the time of bison appearance (ca. A.D. 1250) in the central Texas region (Mauldin et al. 2012). The accumulated evidence indicates Toyah originated from the eastern margin of the Edwards Plateau. “At the end of prehistory, evidence clearly shows Caddo groups regularly extended into the Colorado, Trinity, and Brazos river basin” (Carpenter 2012:260).

The paucity of animal bones recovered from the Late Prehistoric component at 41LM50 is somewhat unusual, as many of the Late Prehistoric Toyah components/sites in central Texas often yield significant quantities of vertebrate faunal remains (i.e., Suhm 1957; Treece et al. 1993b; Johnson 1994; Ricklis 1994; Quigg 1995, 1997; Karbula 2003; Mauldin et al. 2012; also see Dering 2008 for a broader view of Late Prehistoric subsistence patterns). The scarcity of remains potentially resulted from poor preservation, rather than cultural selection. Poor preservation is supported by the lack of quantities wood charcoal remains in this component. The absence of bison bones in the 41LM50 component may argue for an early use period, when bison were absent from the region, before the Perdiz interval. However, the current radiocarbon dates indicate a use period within the last 430 years, likely when bison would have been available in this region.

Turner et al. (2011:177) indicate the Bonham-Alba classification encompasses specimens dating around circa 850 B.P. (ca. A.D. 1100). Story

(1990:364) argues for an intermediate horizon between the Austin and Toyah phases, characterized by Alba points and early Caddoan-like pottery, for the middle Brazos River basin. Both these projected dates are earlier in the sequence, and differ from what is documented at this Late Prehistoric component at 41LM50.

As discussed in greater detail in the research design (see Chapter 5.0), Shafer (2006) proposed that the prairies of east-central Texas, which include the Lampasas County area, were inhabited by Caddo people during the early part of the Late Prehistoric period around 950 B.P. or ca. A.D. 1000 (see Figure 5.1). This possibility was previously raised by Story (1990:364), wherein she suggested an artifact assemblage with Alba arrow points and ceramics closely resembled Early Caddo styles. Story also suggested that local groups could have interacted with Caddoans through trade, marriage, and visitations, as Brown et al. (1987b:38-110) had earlier indicated. Shafer (2006), noting that the dominant point types, Alba and Bonham, do not fit with either the Austin or Toyah constructs, proposed these were part of the Caddoan manifestation, thus ‘Prairie Caddo’. Shafer (2006) points to the presence of a suite of artifacts from a number of sites across the Texas prairies that are techno-stylistically equivalent to comparable materials from the George C. Davis site (41CE19), a large Caddoan village and multiple mound site on the Neches River in Cherokee County in eastern Texas. These artifacts include; a) early Caddo pottery types, b) Alba-Bonham arrow points, c) Gahagan bifaces, d) bone needles, and e) deer metapodial bone beamers (defleshing tools).

To assess if Gahagan bifaces were manufactured during the Late Prehistoric component at 41LM50, TRC conducted an experimental analysis (see Chapters 5.0 and 6.0) on replications of three biface types (Gahagan, Friday, and Harahey) and the resulting debitage from the production of those different biface types, to help determine if the lithic

debitage assemblage from this Late Prehistoric component reflects the production of Gahagan bifaces. Chapter 6.0 provides a thorough discussion of the hypothesis and methods employed in this experiment and its results. The experimental analysis revealed no clear or convincing debitage attributes that allow specific identification of Gahagan biface production from the production of Friday or beveled Harahey bifaces. Therefore, the lack of early Caddo pottery types, the inability to identify Gahagan biface production, the absence of bone needles and deer metapodial bone beamers, result in considerable apprehension in assigning this component to Shafer's (2006) 'Prairie Caddo'.

Furthermore, the four radiocarbon dates from Features 1 and 2 at 41LM50 are much too recent, and do not support the proposed age of 950 B.P. (A.D. 1000) postulated by Shafer (2006) for his 'Prairie Caddo'. Consequently, this Late Prehistoric component is dated by the presence of Alba and Bonham point types to around 300 to 450 B.P. (ca. A.D. 1500 to 1650). This time frame falls in the range Story (1990:329) referred to as Late Caddoan (ca. A.D. 1400 to 1700), or just prior to the historic period. The Late Prehistoric component at 41LM50 radiocarbon dates to a period after the most recent occupations at the George C. Davis site, which Story (1998; Table 2) indicates was about 600 B.P. (ca. A.D. 1350). The period around 300 to 450 B.P. falls in what Collins (2004:123) refers to as the early Historic period. During this period, historical accounts indicate Hasinai Caddo traveled into central Texas to hunt. Which cultural groups employed these point types still requires much additional research, and these groups may eventually be linked to potential Caddo manifestations. This Late Prehistoric component at 41LM50 may reflect 'Prairie Caddo' near the end of prehistory, especially considering the presence of maize at this component. This is a similar interpretation to that arrived at by Carpenter (2012:260) in his review of the Toyah.

If the results from the limited testing of 41LM50 are representative, and this component does indeed have these characteristics of lithic assemblage dominated by non-Edwards chert, lacks Perdiz arrow points altogether, and maize is part of the subsistence, then this Late Prehistoric component may have the potential to provide very valuable insights into the cultural groups that employed the Alba and Bonham point types. Further investigations and a broader assemblage could make significant contributions to: the nature of activities at this locality, a material assemblage to compare with known Toyah assemblages, their group's place in central Texas prehistory, and potentially a greater understanding of group mobility patterns. The location of 41LM50 on the southern edge of the Cross Timbers and the northern edge of the Edwards Plateau is an ideal place to investigate activities and movements of groups from one vegetative zone to another or one homeland into adjacent regions. This border region, near the northern boundary of the Toyah populations, is more complicated than systems within core areas, perhaps it represented an intermediate zone where social groups from central Texas (i.e., Toyah) may have intermingled, practiced exogamy, exchanged/traded technological knowledge and goods (i.e., maize, pottery), and/or allowed joint use for hunting with groups from northeastern Texas (i.e., Caddo). This would be part of what Johnson (1994) termed a 'Shared Toyah area' around the Classic Toyah homeland.

## **9.7 RECOMMENDATIONS FOR 41LM50**

The eligibility testing of 6.5 m<sup>3</sup> documented that the upper 30 cmbs of the Holocene alluvial T<sub>2</sub> terrace contains an intact, well-represented Late Prehistoric component, including Alba and Bonham projectile point types, a limited chipped stone tool assemblage, and two burned rock features. A wood charcoal date combined with two

burned rock residue dates, place this component within the last 430 years. Significantly, starch grain analysis documents the presence of maize on a few chipped stone tools and burned rocks from this component.

The cultural materials present below approximately 30 cmbs to 80 cmbs are scattered, quite limited in quantity and type, lack both diagnostic artifacts and cultural features, and appear in relatively poor context. These scattered artifacts may represent one or more events, based on the two wood charcoal dates that place these scattered materials at roughly 950 B.P.

Based on these findings and results, TRC archeologists recommend the investigated part of site 41LM50 within TxDOT's proposed temporary easement is eligible for listing on the NRHP under Criterion D, and for designation as an SAL. Avoidance is recommended for this project and any future developments for this area. If this area cannot

be avoided for future projects, TRC also recommends mitigation of that part of site 41LM50 lying within the proposed 10 m wide easement, specifically the upper Late Prehistoric component within the top 30 cmbs, before any further land development activities. No further archeological investigations are recommended for the materials underlying this component, below approximately 30 cmbs.

After the review of the interim report (Quigg and Frederick 2005), the Brownwood District engineers decided to avoid further impact on prehistoric site 41LM50 in the proposed easement at Lynch Creek Bridge East. Instead of using the temporary easement to allow the continued flow of vehicle traffic, the FM 580W roadway was closed to traffic, and bridge construction activities were performed within the existing right-of-way. This strategy avoided additional impact to the investigated portion of site 41LM50

## **10.0 TESTING RESULTS AT 41LM51**

J. Michael Quigg, Paul M. Matchen, and Charles D. Frederick

### **10.1 INTRODUCTION**

This chapter presents the findings from the August 2004 evaluation and testing investigations within the proposed easement through part of site 41LM51. This was a previously unrecorded prehistoric site on the south side of FM 580W immediately east of Lynch Creek Bridge West. At 41LM51, Lynch Creek flows from north to south, and the highway crosses Lynch Creek east-west. This prehistoric site contains multiple occupations in two completely different landform and stratigraphic settings. Prehistoric artifacts are within the top 80 cm of a high T<sub>2</sub> terrace that exhibits a beveled edge along the western side that gradually slopes down to a much lower and smaller alluvial T<sub>0</sub> terrace. The lower terrace also contains multiple components that are well-stratified in the alluvial deposits that are about 140 to 150 cm deep.

The construction of FM 580W destroyed an unknown percentage of the northern side of 41LM51. At the time of the archeological investigations the existing pavement was roughly 3 m (10 ft.) below the high T<sub>2</sub> terrace and roughly at the same elevation as the low T<sub>0</sub> terrace. A small wedge of roughly 40 m<sup>2</sup> of the low T<sub>0</sub> terrace still existed within the existing right-of-way immediately adjacent to Lynch Creek and immediately south of the bridge. The proposed temporary low-water crossing slatted for use during bridge construction required a temporary easement on private land immediately south of the current road (Figure 10-1). This proposed easement was projected to extend about 10 m (32 ft.) south from the existing southern boundary of the right-of-way and extend from the creek bank roughly 120 m (391 ft.) eastward, where it would merge back with the existing roadway.

Both terraces and the beveled edge of the high terrace contain buried evidence of this prehistoric site within the investigated easement. The easement and the broader area are covered with many large oak and small juniper trees with sparse grasses



**Figure 10-1. View east of proposed easement on south side of roadway with Lynch Creek in foreground, and western end of site 41LM51 with completed TU 4 in cutbank.**



**Figure 10-2. View of tree covered upper T<sub>2</sub> terrace surface along proposed easement across 41LM51.**

between the trees (Figure 10-2). The two terraces exhibit relatively flat surfaces with the low terrace about 3 m (10 ft.) above the creek bottom. The east-west width of the low T<sub>0</sub> terrace varies from 10 to 15 m wide within the proposed 10 m wide easement. From this low terrace, the land gradually slopes up to the top of the higher T<sub>2</sub> terrace over about 15 m. The top of the higher T<sub>2</sub> terrace is about 6 m (20 ft.) above the creek bottom and is much more extensive than the low terrace. The higher terrace continues roughly 100 m southward with the southeastern edge demarcated by a shallow, small creek channel near the base of a higher sloping upland that enters Lynch Creek roughly 150 m downstream from the bridge. Part of this small creek channel appears fed by small seeps or springs along the base of the higher slope.

Multiple east-west cow trails extend from Lynch Creek up across the two terraces and intervening slope. These trails provided the initial window into the subsurface allowing the discovery of this prehistoric site. They exposed cultural materials as they crossed the upper edge of beveled higher terrace, roughly 25 to 27 m south of the existing right-of-way fence. This material was estimated to be roughly 30 cmbs. During a visit to the site in

May 2004, roughly 160 burned rocks (some scattered and some clustered), about 8 pieces of lithic debitage, 2 bifacial tools, and 1 edge-modified flake were observed over a surface area of about 14 m<sup>2</sup> along the beveled sloping edge. No prehistoric cultural materials were exposed on the surface of either terrace. An occasional piece of lithic debitage and burned rock was also observed near the top of the heavily vegetated, partially exposed road cut edge of the high T<sub>2</sub> terrace along the southern right-of-way fence that parallels FM 580W. These few exposed cultural items indicate the site extended for some distance along the southern side of the roadway.

## **10.2 SITE SPECIFIC PROCEDURES**

The geoarcheologist walked the proposed easement and the surrounding area to obtain a broader understanding of the site specific setting. The low T<sub>0</sub> terrace, specifically the small wedge that remained inside the existing right-of-way, exhibited a nearly vertical exposure along Lynch Creek (Figure 10-3). The geoarcheologist documented this creek side cutbank exposure to a depth of 240 cmbs (Appendix A). Two paired samples of bulk sediment and directly associated tiny charcoal were collected from this profile



**Figure 10-3. Holocene alluvial deposits in vertical cutbank on east edge of Lynch Creek with completed TU 4 at 41LM51.**

exposure. The upper sediment and charcoal sample was collected from near the top of Zone 4, a dark gray to very dark gray (10YR 3.5/1) AC horizon nearly 75 cmbs. The second pair of samples was collected from Zone 13, the fifth AC horizon at 220 cmbs. These samples were collected in anticipation of radiocarbon dating but were never submitted (see Chapter 7.0 for stratigraphic interpretations and Appendix A for details on this cutbank).

During the initial field visit the projected size of the proposed easement across the lower  $T_0$  terrace was in question and appeared very limited in area. The decision to place Trench 1 within the existing right-of-way was to allow the much narrower APE across the lower  $T_0$  terrace to be investigated through hand-excavations rather than being significantly impacted by the excavation of a trench in that narrow area. Trench 1 was excavated at the southern edge of the existing right-of-way next to the fence, opposite the low alluvial  $T_0$  terrace in the adjacent proposed easement near the creek cutbank (Figure 10-4). The 16 m long by 3 m wide trench with a safety step on the northern side paralleled the

right-of-way fence. The trench extended from the back edge of the low  $T_0$  terrace, across the slope, and stopped just short of the higher  $T_2$  terrace. Trench 1 was excavated to 3 m below the existing surface and penetrated into Pleistocene deposits.

Trench 1 exposed a layer of tightly clustered, shallowly buried burned rocks (eventually designated Feature 1) under a tree stump with numerous roots in the southern wall at the eastern end. Three bulk sediment samples were collected from a vertical column in the south wall near the midpoint of the trench. The highest sample was collected from a yellowish-brown (10YR 5/4, moist) loamy sand in the lower AB horizon boundary at roughly 30 cmbs. A second loamy sand sample was collected from the upper yellowish-brown (10YR 5/4, moist) Bk horizon boundary nearly 35 cmbs. The third sample was collected from the top part of the grayish-brown (10YR 5/2, moist) sandy loam Ab soil horizon at 242 cmbs, which might be very early Holocene in age. It was anticipated these samples would be radiocarbon dated and provide general date estimates for the deposits.

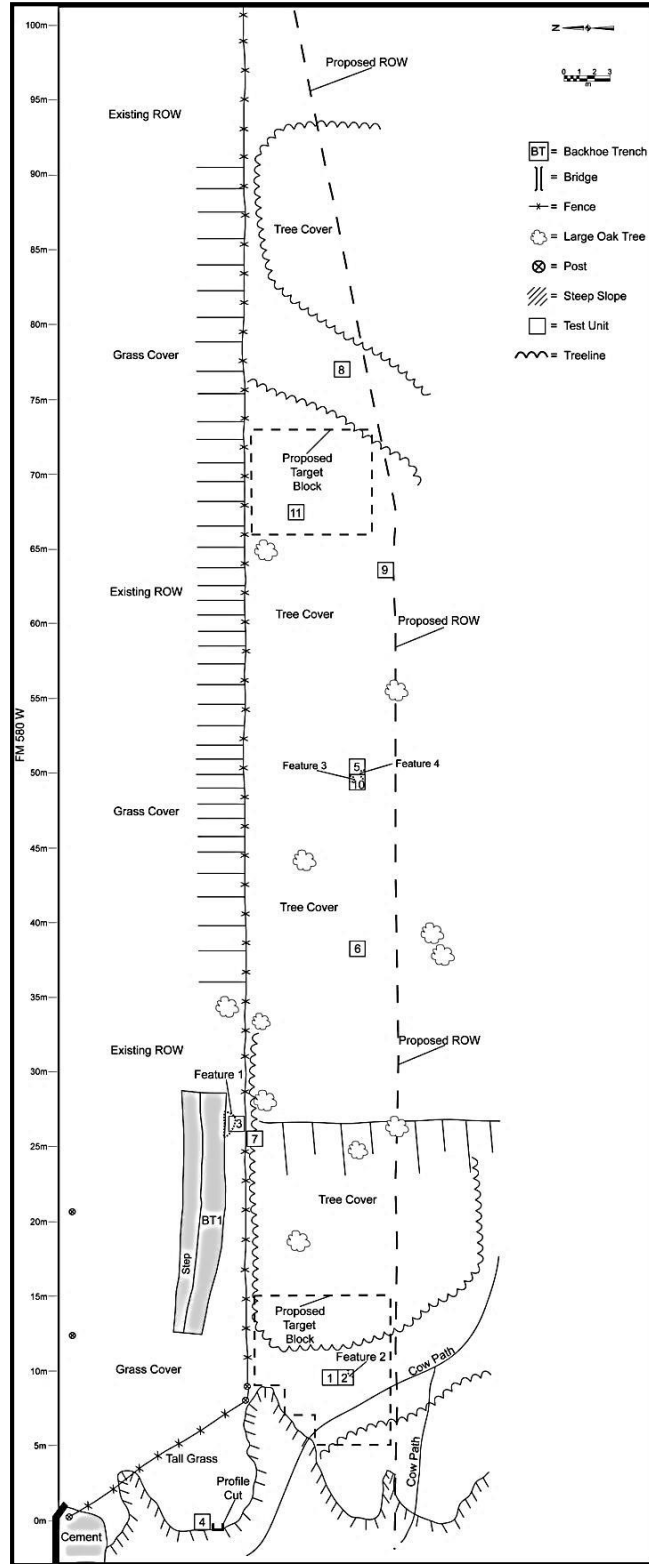


Figure 10-4. Plan sketch map of site 41LM51 indicating investigated areas in the temporary proposed easement on the south side of the current right-of-way.

A total of 11 1-by-1 m test units, assigned TU 1 through 11 and encompassed 10.3 m<sup>3</sup> were hand-excavated across the APE of 41LM51 (see Figure 10-4). TUs 1, 2, and 4, totaling 4.6 m<sup>3</sup>, were excavated into the low T<sub>0</sub> terrace deposits near the creek. TUs 1 and 2 (totaling 2.6 m<sup>3</sup>) were side-by-side to form a 1-by-2m window to investigate the deeper alluvial deposits in the low terrace immediately south of the right-of-way fence at the west end of the APE (Figure 10-5). These two test units penetrated to depths of 100 and 160 cmbs, respectively, with the deeper test terminated in apparent Pleistocene or early Holocene gravel mixed with sand.

A 50-by-50 cm round test hole was excavated below the last screened level to investigate the thickness of the gravels. A mottled sandy clay and gravel continued to minimally 175 cmbs. Test Unit 4 was excavated in the wedge shaped area of the low terrace that remained within the existing right-of-way at the very western end of the APE. This test unit was excavated to 200 cmbs (2.0 m<sup>3</sup>). Test Units 3 and 7 (0.9 m<sup>3</sup>) were excavated along the western beveled edge of the high T<sub>2</sub> terrace. Test Unit 3 was established 20 cm south of the trench edge leaving a baulk of sediment between Trench 1 and TU 3. This unit was excavated near the eastern end of Trench 1 and within the existing right-of-way to investigate the tight cluster (Feature 1) of nearly horizontal burned rocks exposed in the upper 30 to 40 cm of the south wall of Trench 1. Subsequently, TU 7 was excavated to roughly 45 cmbs immediately south of the right-of-way fence on the southwestern edge of TU 1 to further investigate Feature 1, which was partially exposed in TU 1.

TUs 5 and 6, and 8 through 11 (4.8 m<sup>3</sup>) were excavated within the APE across the higher T<sub>2</sub> terrace (see Figure 10-4). TU 6 was towards the western end of the high terrace about 11 m east of the beveled edge. TU 8 was the eastern most test unit, about 50 m east of the beveled edge, with TUs

5, 9, 10, and 11 scattered in between. TU 5 and 10 were side-by-side and formed a 1-by-2 m excavation about 11 m east of TU 6. TU 9 was about 13 m east of TUs 5 and 6 on the southern margin of the proposed easement. TU 11 was about 9 m west of TU 8, and 4 m northeast of TU 9. These six test units were hand-excavated from the existing surface to variable depths between 70 and 90 cmbs for a total of 4.8 m<sup>3</sup>, but no excavations reached a gravel deposit or bedrock. All test units penetrated a sandy silty loam.

Wall profiles were drawn for TUs 8 through 11 with a profile for Feature 1 as well (Figure 10-6). Plan maps were drawn for all four cultural features (Features 1 through 4) identified. A sketch map of the proposed long and narrow APE, the proposed temporary easement, was created that showed the locations of the 11 1-by-1 m test units, the existing right-of-way fence, Trench 1, and the large oak trees in relationship with the creek margin and bridge (see Figure 10-4).

Following the excavation of the test units, some 67 small sediment column samples from various test units and the creek side profile were systematically collected in close intervals for potential paleoenvironmental analyses. These include 19 samples from the lower T<sub>0</sub> terrace in a single column in TU 2 that ended at 190 cmbs. Thirteen sediment samples were collected from TU 5, another 10 samples from TUs 6 and 8, 15 samples from TU 9, and 3 samples from TU 10.

In the following sections, the cultural materials recovered from all test units is presented for the area investigated, beginning with the features encountered followed by classes of materials recovered. This is succeeded by a presentation of the horizontal and vertical distribution of the cultural stratigraphy, age of the deposits, and geoarcheological findings for each identified cultural assemblage, followed by comments concerning the integrity of the cultural





Figure 10-5. Profile of alluvial deposits exposed in TU 2 in low  $T_0$  terrace, 41LM51.



**Figure 10-6. Profiling north wall of TU 10 at 41LM51.**

assemblages. Finally, a presentation of the individual cultural components by time period is presented.

### **10.3 CULTURAL FEATURES**

Four prehistoric features, dispersed across three different topographic settings, were recognized in the 10.3 m<sup>3</sup> of hand-excavations (see Figure 10-4). Feature 1 was shallowly buried near the northwestern edge of the beveled high T<sub>2</sub> terrace near the top of the deposits. Feature 2 was deeply buried in the low alluvial terrace. Features 3 and 4 were shallowly buried towards the middle of the proposed easement across the high T<sub>2</sub> terrace. Each feature is described, discussed and interpreted below.

#### **10.3.1 Feature 1**

This feature was exposed in the south wall at the eastern end of Trench 1 in the upper 30 to 40 cm. In the trench profile, it first appeared as a layer of four tightly spaced burned rocks in a horizontal line about 45 cm long. Further examination revealed another three burned rocks that extended

roughly 20 cm further west on the same plane, with one additional burned rock another 40 cm further west (Figures 10-7 and 10-8). The measured depths of these burned rocks varied slightly as the ground surface sloped down to the west towards the creek. Unfortunately, two rotting tree stumps and small bushes were directly above the exposed burned rocks and many small to medium size roots (4 to 6 cm diameter) extended downward through the feature and around the burned rocks, which disrupted the cultural integrity. Modern armadillo bones, a few glass fragments, and a couple of metal fragments were present just below the surface around these stumps.

To further investigate the feature, a 1-by-1 m test unit (TU 3) was established 20 cm south of the trench edge towards the western side of the largest tree stump. This placed the test unit's southern boundary along the right-of-way fence, with the two stumps encompassing most of the northeast quadrant of the test unit. Hand-excavations encountered only four tightly clustered burned rocks along the northern edge of



**Figure 10-7. Profile of Feature 1 on southern side of Trench 1 with TU 3 in background at 41LM51.**

TU 3. This tight cluster of sizable burned rocks and the absence of other burned rocks across the southern three-quarters of TU 3 indicated the southern boundary of Feature 1 was within 30 cm of the northern edge of TU 3. The 20 cm wide baulk between the trench and TU 3 was then removed, which exposed more tightly clustered burned rocks that created a small section of this well-defined burned rock feature. Excavation of TU 3 and the 20 cm wide baulk, revealed a well-defined cluster of burned rocks that measured 130 cm east-west and minimally 50 cm north-south with a significant part removed by Trench 1 (Figure 10-8).

Excavations yielded 25 burned rocks that weighed cumulatively 21,300 g for an average rock weight of 852 g. Two rocks were in the 4.1 to 9 cm diameter size class, another 15 rocks were in the 9.1 to 15 cm size class, and 8 rocks were greater than 15 cm.

No charcoal lens, oxidized area, nor basin was detected or observed around the burned rocks. These burned rocks appeared on a level plane that sloped down slightly to the west, as the actual surface measurements varied from 32 to 41 cmbs

using a single point as a reference. Only two burned rocks were slightly tilted, but in different directions, and floral turbation from the tree roots may have caused the tilting.

Burned rocks were predominately limestone slabs, with one sandstone piece. These slabs were mostly complete, although two or three had cracked in place. No soil color change was observed around the burned rocks, but ants, rotting wood, and tree roots had caused minor disturbances. Six burned rocks, one of sandstone, were collected for future analysis. This tight cluster of flat lying limestone slabs is interpreted as a flat cooking hearth or griddle used for a very short time based on the lack of cultural material in association.

The excavated area in TU 3 and the baulk between 28 and 41 cmbs on the southern and outside side of Feature 1 yielded 8 pieces of lithic debitage, 3 *Rabdotus* snail shells, modern armadillo bones, but no additional burned rocks. Many calcium carbonate nodules, between 7 and 20 mm in diameter, were present in the surrounding sediments. Although no direct age was obtained

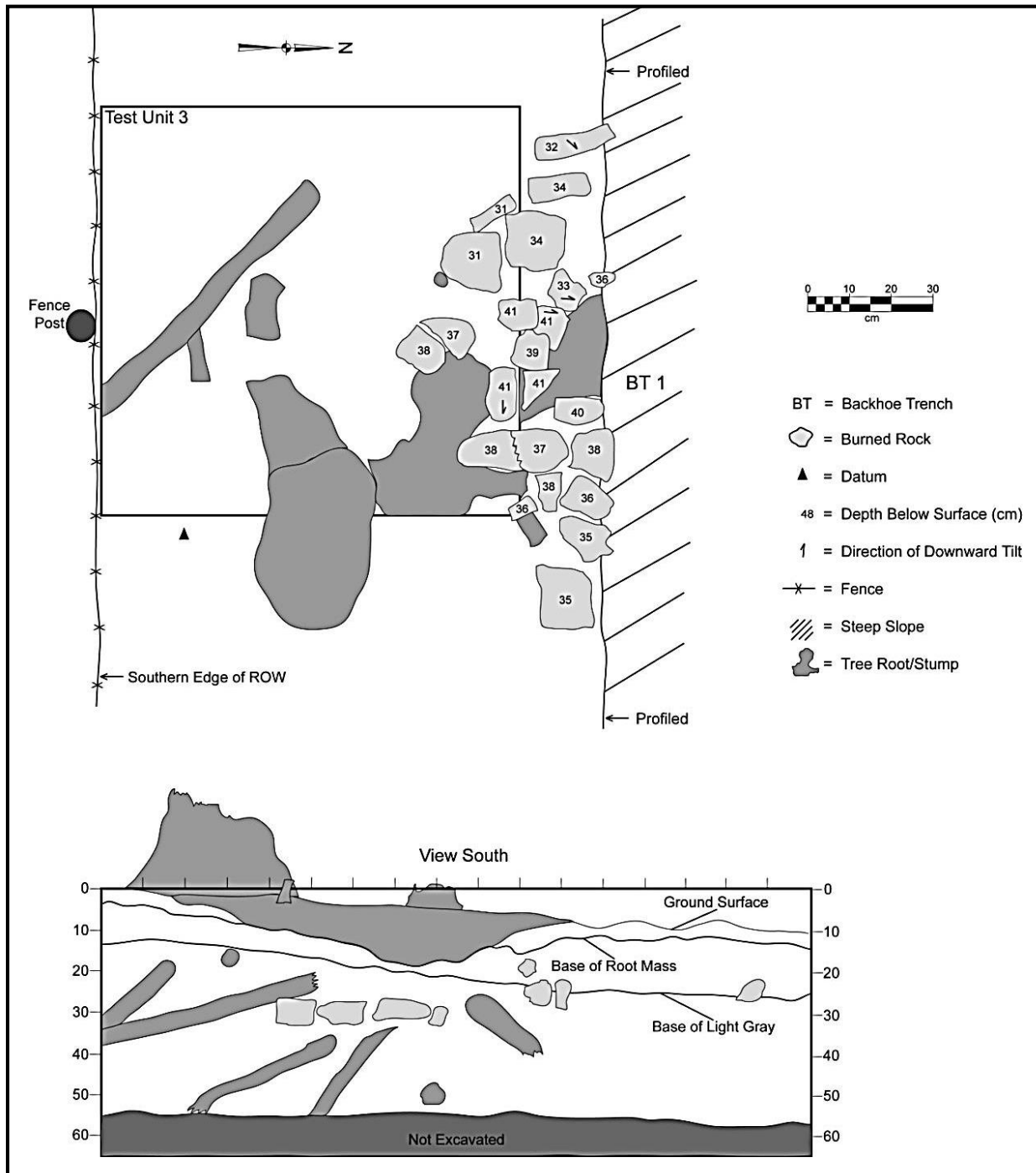


Figure 10-8. Plan view and profile drawing of Feature 1 at 41LM51.

and no diagnostic projectile points were directly associated with Feature 1, the presence of calcium carbonated nodules in the sediments just below the rocks, coupled with the recovery of Late Archaic projectile points from the excavations further east across this high terrace, indicate a probable Late Archaic age for this feature. The age is estimated sometime between ca. 1500 and 3000 B.P.

### 10.3.2 Feature 2

Feature 2 consisted of a small ill-defined loose aggregation of small burned rocks between 85 and 95 cmbs in TU 2 in the low T<sub>0</sub> terrace. The burned rocks were concentrated in the southeastern corner of the test unit and appeared to continue into the eastern and southern walls (Figure 10-9). The extent and size of Feature 2 is unknown. Consequently, the overall shape and the total number of burned rocks are unknown. The excavated part measured roughly 60 cm east-west and 40 cm north-south. That irregularly outlined area contained roughly 10 burned rocks that weighed cumulatively approximately 1,126 g, for an average weight of 113 g per rock. Nine pieces were less than 9.1 cm in diameter and one was between 9.1 and 15 cm in diameter. All burned rocks were limestone. No patterning, basin, charcoal, or oxidation was observed around these burned rocks. These rocks were at slightly different elevations, but did not appear in a basin. Ten burned rocks, two bags of sediment and possible charcoal flecks were collected from Feature 2. However, what were thought to be possible charcoal flecks were later determined to be tiny pieces of coal or shale.

Four limestone burned rocks (#102-3-1 through #102-3-4) and a sediment sample were sent for starch grain analysis. Dr. Perry's methods, results and interpretations are presented in Appendix D. The analysis of the four burned rocks yielded a single gelatinized starch grain that was unidentifiable. A 53 g sediment sample (#102-4-b) from around the burned rocks failed to yield starch

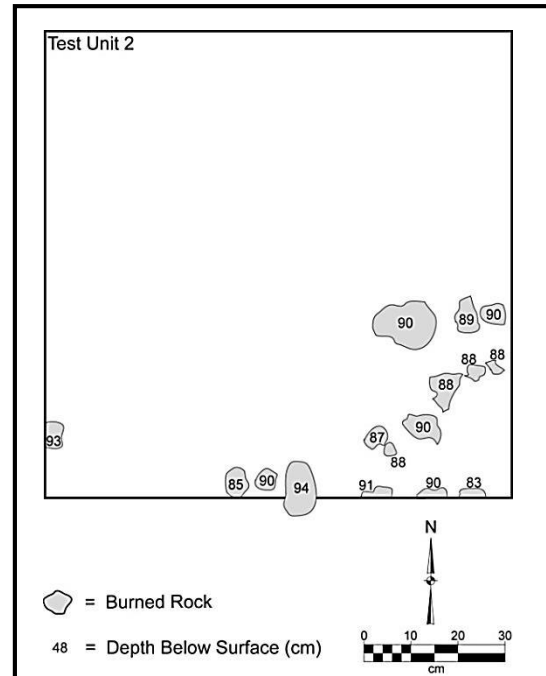


Figure 10-9. Plan view drawing of Feature 2 at 41LM51.

grains (Appendix D). A 60 g sediment sample (#104-004) from around the burned rocks also did not yield starch grains (Appendix D). A control sample (#117-3-b) from outside Feature 2, from approximately 86 to 88 cmbs, was also analyzed, but again yielded no starch grains.

Dr. Sudbury reports finding phytoliths in both the feature and adjacent control samples (Appendix F). The feature sample yielded 38.7 percent cool season Pooids, 25.0 percent warm moist season Panicoids, and 36.3 percent hot dry season Chloridoid phytoliths (Appendix F). Burned short cells account for 9.8 percent (20 cells), whereas burned tree cells account for 0.35 percent of the assemblage. Based on the phytolith assemblage Feature 2 may have been in use well into the fall (Appendix F). No phytoliths represented indicate collected seeds or other food resources.

A 3.7 liter sediment sample (#102-4c) from 80 to 90 cmbs in TU 2 was floated. The heavy fraction (151.7 g) yielded only 8 tiny pieces of chert. The light fraction (3.2 g) did not yield any burned

organic remains. This loose cluster of limestone burned rocks is interpreted as a discard pile of rocks presumably used to heat/cook foods. However, the negative analytical results cannot provide evidence of what foods were cooked.

In TU 2, the 10 cm level between 80 to 90 cmbs surrounding Feature 2 yielded 19 pieces of lithic debitage, 3 *Rabdotus* snail shells, 1 small fragment of a mussel shell, 1 broken Gower point (#19-10), 1 edge-modified tool (#19-13, a graver), and 20 small burned rock fragments that weighed 200 g cumulatively. Also present, in light brown silty sand, were about 100 small, rounded gravels that weighed about 600 g cumulatively. Small but frequent calcium carbonate nodules were also present throughout this level. The 10 cm level between 90 and 100 cmbs yielded 14 pieces of lithic debitage, 33 burned rock fragments, and 1 *Rabdotus* shell. About 60 small rounded pebbles, which weighed cumulatively about 400 g, were also in this same level. The graver (#19-13) was subjected to high-power microscopic use-wear analysis. The results revealed possible raphides, no observed use-wear, and therefore an unknown function (Appendix C).

Three mostly complete *Rabdotus* snail shells (#19-6a) from the screened sediment that surrounded Feature 2 were radiocarbon dated. These combined snails yielded a  $\delta^{13}\text{C}$  (-10.5‰) corrected AMS date of  $6750 \pm 50$  B.P. (UGA-14422). Feature 2 and the Gower point generally date to this period, which indicate that the broken Gower point and snail shells were not significantly displaced and were generally associated. The Gower point is considered part of the split stem series of point types, which are part of the Early Archaic period, and earlier than the Martindale and Uvalde points (Collins 1995, 2004; Johnson and Goode 1994). This cultural use period is supported by the *Rabdotus* shell date.

### **10.3.3 Feature 3**

This cluster of 15 burned rocks was first recognized in the north half of TU 10 between 40 and 50 cmbs. Two burned rocks extended into the north wall and indicate that this cluster was not contained entirely within TU 10. The excavated part Feature 3 was photographed and mapped. All 15 burned rocks were counted and weighed by size class, and collected for future analyses. A bulk sediment sample (#103-004) from under the feature rocks between 42 and 47 cmbs was also collected for future analyses.

Excavations revealed a cluster of burned rocks that measured about 70 cm east-west and at least 30 cm north-south. The feature extends an unknown distance northward beyond the limits of the excavation. Eight burned rocks were in a tight cluster measured approximately 25-by-35 cm, with two larger burned rocks (15 to 20+ cm in size) about 15 cm further west (Figures 10-10, 10-11 and 10-12). All observed feature burned rocks had basal elevations between 41 and 46 cmbs, with the westernmost pieces slightly tilted down to the east. The 15 burned rocks weighed 8,100 g cumulatively, with an average of 540 g.

Four pieces were between 1 and 4 cm in diameter, three were 4.1 to 9 cm, six were 9.1 to 15 cm and two were greater than 15 cm. No layered rocks, oxidized sediment, charcoal lens, or discolored sediment were observed in this sandy loam. The burned rocks were a coarse limestone and rested on a slightly uneven surface. A 4.0 liter sediment sample (#103-4) from 42 to 44 cmbs in TU 10 was floated. The heavy fraction (86.9 g) yielded 41 tiny pieces of chert, 1 tiny burned rock and fragmented snail shells. The light fraction (2.3 g) did not yield any burned organic remains.

Four burned limestone rocks (#103-3-1, #103-3-2, #103-3-3, and #103-3-4), one edge-modified flake (#103-10), and a sediment sample (#103-4-b) were sent for starch grain analysis. The four rocks

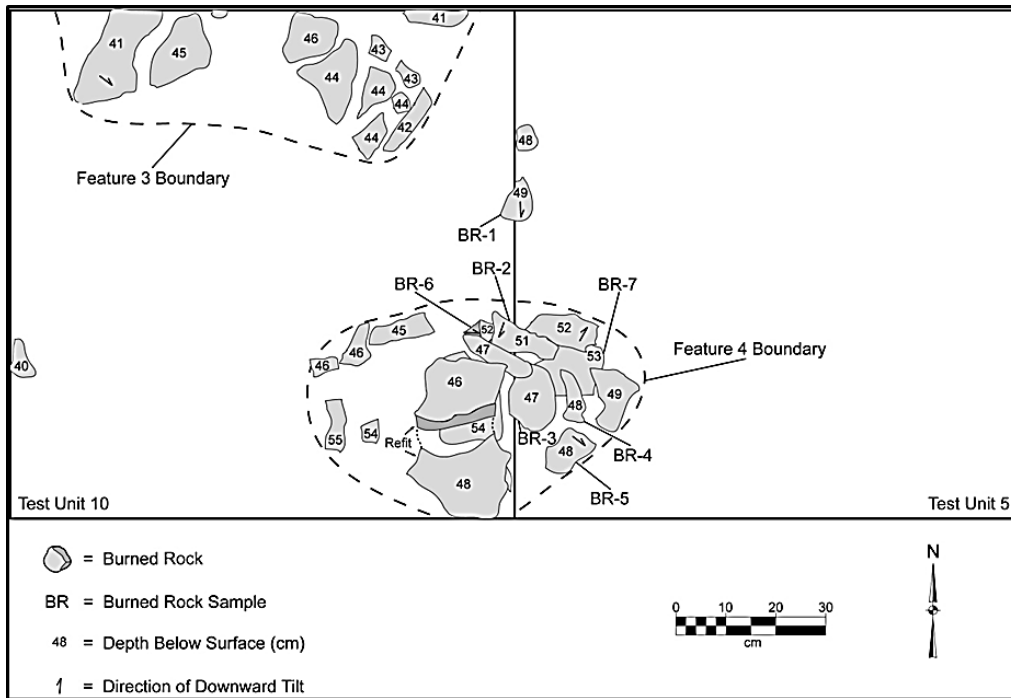
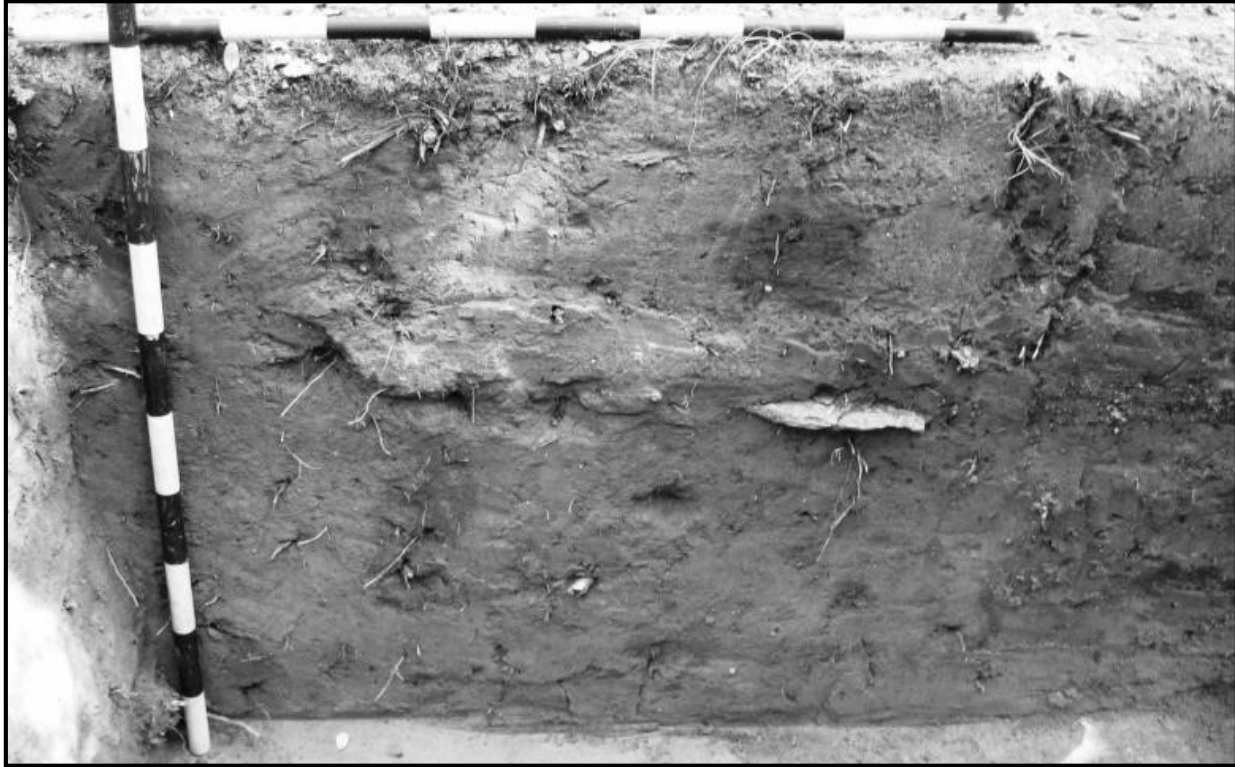


Figure 10-10. Plan view drawing of Features 3 and 4 at 41LM51.



Figure 10-11. Top view of exposed burned rocks in Feature 3 (top) and Feature 4 (bottom) in TU 10, 41LM51.





**Figure 10-12. Profile of north wall of TU 10 with part of Feature 3 extending into wall, 41LM51.**

yielded one unidentified grass, one maize, and one gelatinized starch grain (Appendix D). The large (57 g) washed edge-modified flake from inside Feature 3 did not yield any starch grains. The 50 g sediment sample from amongst the burned rocks also did not yield any starch grains (Appendix D). The lack of starch grains in the sediment indicates those starch grains on the rocks are from cultural activities rather than from the surrounding soil.

A sediment sample (#103-004) from around the burned rocks at 42 to 47 cmbs yielded a phytolith assemblage. This sample yielded 32.7 percent cool season Pooids, 35.9 percent warm season Panicoids, and 31.4 percent hot dry season Chloridoid phytoliths (Appendix F). Burned short cells account for 9.8 percent (20 cells), whereas burned tree cells account for 0.35 percent of the assemblage. Based on the phytolith assemblage Feature 2 may have been in use well into the fall (Appendix F). No phytoliths represented indicate collected seeds or other food resources. Burned

short cell phytoliths account for 1.18 percent (3 cells) and burned tree phytoliths account for 0.27 percent (Appendix F). Based on the present phytolith assemblage identified these data likely represent a late summer early fall occupations (Appendix F).

The 40 to 50 cmbs level of TU 10 yielded 85 pieces of lithic debitage, 4 edge-modified flakes (#88-10, #88-11, #88-12, and #88-13), 1 mussel shell fragment (#88-006; 4.1 g), 4 *Rabdotus* shells, plus 21 small burned rock fragments (450 g cumulatively) scattered across the level. This feature is interpreted as a discard pile and probably associated with Feature 4 (see below). No absolute age was determined for this burned rock cluster, although the presence of a broken Frio point within the adjacent unit is and possibly associated Feature 4 implies an age of ca. 1500 to 2000 B.P.



#### 10.3.4 Feature 4

Feature 4 was first observed during the excavation of Level 6 (50 to 60 cmbs) in TU 5, which exposed six tightly clustered burned rocks near the southwestern corner. This cluster appeared to continue into the western wall. The entire level was excavated, leaving these burned rocks *in situ*. Eventually, TU 10 was opened on the western side and excavated down through this level, which exposed the remainder of this cluster. The feature was photographed and mapped.

The burned rocks were counted and weighed by size class, and a sample of 7 burned rocks was collected for future analyses. A sediment sample from under the feature rocks was also collected. Some sediment amidst and around the burned rocks was also screened, and materials collected include flakes, stone tools, and snail shells.

Excavations revealed this tight cluster of burned rocks measured about 65 cm east-west and at least 40 cm north-south. This tight clustered was thought to represent the entire feature, although approximately 5 smaller burned rocks about 10 cm west of the tighter grouping may have been slightly displaced (see Figures 10-10 and 10-11).

The two largest pieces (each roughly 12 to 15 cm in diameter) on the western side of the tightest cluster fit together into one large rock roughly 25 cm in diameter. Four burned rocks (two between 12 to 15 cm in diameter, and two less than 10 cm) were directly below the tight cluster of burned rocks. The upper layer of burned rocks was between 45 to 49 cmbs, and the lower layer was between 52 and 54 cmbs.

This layering indicates a probable basin in an apparently intact hearth/heating element feature. However, no obvious sediment staining, oxidation, or charcoal lenses were detected in the sandy loam. Twenty-three burned rocks weighed 13,100 g for an average of 570 g per rock. The majority of feature rocks were coarse-grained limestone. These rocks

varied in size with 18 percent in the 1 to 4 cm size, 23 percent in the 4.1 to 9 cm, 40 percent in the 9.1 to 15 cm, and another 18 percent greater than 15 cm.

A small 2.2 liter sediment sample (#104-4) from 45 to 55 cmbs in TU 10 was floated. The heavy fraction (18.5 g) yielded 15 tiny lithics with tiny fragments of mussel and snail shells. The light fraction (1.3 g) did not yield any burned organic remains.

Four burned limestone rocks (#104-3-2, #104-3-4, #103-3-5 and #103-3-6) and one sediment sample (#104-4-b) from between 48 and 52 cmbs were sent for starch grain analysis. One burned rock (#104-3-2) yielded a single unknown grass grain, whereas the sediment from this feature also yielded one unknown starch grain (Appendix D). A control sediment sample (#130-3-a) from 45 to 47 cmbs in TU 5 did not yield starch grains (Appendix D). Therefore, the grass starch was likely part of the cultural food residues or part of the starting fuel for the fire.

A 64 g sediment sample (#104-004) from around the burned rocks at 45 to 55 cmbs yielded a short cell phytolith assemblage that consisted of 35.9 percent cool season Pooids, 28.7 percent warm moist season Panicoids, and 35.4 percent hot dry season Chloridoid phytoliths (Appendix F). The phytolith assemblage contained a single phytolith that likely represents a possible gathered food resource, in the Commelinaceae family. Burned short cells account for 2.5 percent (5 cells), whereas burned tree cells account for 0.5 percent of the assemblage. Based on the phytolith assemblage Feature 2 may have been in use well into the fall (Appendix F). No phytoliths represented indicate collected seeds or other food resources. Based on the present phytolith assemblage present the occupation likely represents a mid to late summer event (Appendix F).

Screened sediment from 50 to 60 cmbs in TU 5 yielded 95 pieces of lithic debitage, 1 complete Lange point (#89-10), 2 broken bifaces (#89-11 and #89-12), 4 edge-modified informal tools (#88-13, #88-14, #88-15, and #88-16), 1 mussel shell fragment (2.4 g), and 34 pieces of small burned rocks. The sediment that surrounded the feature was the same brown sandy loam.

Five of the 14 *Rabdotus* snail shells collected from the sediment that surrounded Feature 4 were radiocarbon dated. These combined shells (#89-6a) yielded a  $\delta^{13}\text{C}$  (-8.7‰) corrected AMS date of 5860  $\pm$  50 B.P. (UGA-14426). This radiocarbon date is roughly 3,800 years too old for the apparently associated Frio point. The present interpretation is the *Rabdotus* shell date is too old to reflect the true age of this feature (see Section 7.3.3). These small shells are easily displaced in these sandy loam sediments. On the basis of the recovered projectiles in and around Feature 4 and extrapolating their known ages from other sites, this feature more likely dates to between 2000 to 3000 B.P. The *Rabdotus* shell date would be acceptable for the earliest events at this locality. Some rodent burrows were detected in the lower levels, but were difficult to see at this level.

Feature 4 is interpreted as an *in situ* cooking hearth with two layers of burned rocks that created a small shallow basin. Although Feature 3 was a few centimeters higher, it appeared that these two features were part of the same occupation zone. If so, the rocks in Feature 3 potentially could have been discarded from the *in situ* Feature 4 hearth. Many Feature 3 rocks were of sufficient size to still be useable, and may indicate that these rocks were stockpiled for later use. Most scattered burned rocks present within TU 5 and TU 10 were less than 4 cm in diameter, and may have been associated with these two features. The screened sediment from around the feature burned rocks was also a brown sandy loam that yielded a broken Frio point

(#104-10) *in situ* at 59 cmbs, and 18 relatively small pieces of lithic debitage.

## **10.4 MATERIAL CLASSES AND FREQUENCIES**

This section presents the different classes and frequencies of cultural materials recovered during this testing/evaluation program from the proposed easement within site 41LM51. This includes not only artifact quantities, but also horizontal and vertical patterning and density of materials per cubic meter. The cultural material was derived from multiple topographic settings and multiple components and reflects several vertically and horizontally dispersed components. The stratigraphy and cultural components will be elaborated following the presentation of the cultural materials below (see Section 10.6).

### **10.4.1 Lithic Debitage**

#### **10.4.1.1 Physiographic Setting and Horizontal and Vertical Distribution**

A total of 2,078 lithic debitage were recovered from 41LM51. Lithic debitage was differentially distributed horizontally and vertically relative to the different physiographic settings present (Table 10-1). The three different settings yielded different aged deposits and various cultural components were identified in these settings. Two components were recognized in the lower T<sub>0</sub> terrace, a probable Toyah in the upper part and a probable Gower in the lower part. These were both relatively well-defined and stratigraphically separated.

The cultural deposits in the upper terrace are not well-defined and are more vertically dispersed. Multiple Late Archaic events are present but could not be separated into discrete events. The debitage analysis targeted the probable Toyah and Gower components plus a sample from two levels in two units assigned to the Late Archaic.

**Table 10-1. Vertical and Horizontal Distribution of Lithic Debitage by Physiographic Setting.**

Level	Depth (cmbs)	Lower T <sub>0</sub> Terrace			Beveled Edge		Upper T <sub>2</sub> Terrace						Total by Level
		TU 1	TU 2	TU 4	TU 3	TU 7	TU 5	TU 6	TU 8	TU 9	TU 10	TU 11	
1	0 - 10						1		44	2			47
2	10 - 20				5	22	116	50	93	23	157	55	521
3	20 - 30	6	4		14	63	48	21	62	17	87	31	353
4	30 - 40	1	2	1	8	6	62	24	25	12	64	71	276
5	40 - 50					3	74	22	11	7	98	73	288
6	50 - 60	1	3				77	31	9	5	108	33	267
7	60 - 70	4	5				39	9	5	1	63	10	136
8	70 - 80	4	8				29		3		29		73
9	80 - 90	17	19				26				26		88
10	90 - 100	5	12										17
11	100 - 110		7										7
12	110 - 120		1										1
13	120 - 130		1										1
14	140 - 150		1										1
15	150 - 160												0
16	160 - 170												0
18	170 - 180			2									2
<b>Total by TU</b>		<b>38</b>	<b>63</b>	<b>3</b>	<b>27</b>	<b>94</b>	<b>472</b>	<b>157</b>	<b>252</b>	<b>67</b>	<b>632</b>	<b>273</b>	<b>2078</b>
<b>Total by Landform</b>		<b>104</b>			<b>121</b>		<b>1853</b>						
<b>Total by Component</b>		<b>13</b>	<b>= Toyah</b>		<b>60</b>		<b>= Gower</b>	<b>357</b>	<b>= Late Archaic</b>				

**Lower T<sub>0</sub> Terrace**

TUs 1, 2, and 4 were excavated in the low T<sub>0</sub> terrace. These yielded 38, 64, and 3 lithic debitage respectively, to total 104 pieces cumulatively, or 5 percent of the total recovered for the site (see Table 10-1). One major peak and one minor peak in vertical distribution were distinguishable in TUs 1 and 2. The minor peak ( $N = 13$ ) accounts for 13 percent of the low terrace lithic debitage, was encountered between 20 and 40 cmbs, and later designated as the probable Toyah component (see Toyah component below). The major peak ( $N = 60$  or 58 percent of the low terrace debitage) occurred

in TUs 1 and 2 between 80 and 110 cmbs. The major peak was associated with a Gower point (#19-10) and was designated the probable Gower Early Archaic component (see Gower component below).

**Upper T<sub>2</sub> Terrace**

The six units (TUs 5, 6, 8, 9, 10, and 11) across the high T<sub>2</sub> terrace yielded relatively high concentrations of lithic debitage ( $N = 1,853$  cumulatively), accounting for 89 percent of the total site debitage (see Table 10-1).

TUs 5 and 10 yielded a total of 1,104 pieces (472 and 632 pieces respectively), account for nearly 60

percent of the lithic debitage from the upper terrace, and 53 percent of the total site debitage. The high peak in frequency occurred between 10 and 20 cmbs ( $N = 116$  and  $157$  respectively). The moderate peak in frequency in these test units in Levels 5 and 6, between 40 to 60 cmbs ( $N = 151$  and  $206$  respectively;  $357$  cumulatively) was designated the Late Archaic component (see component discussion below). Test Unit 6 reveals a moderate overall frequency ( $N = 157$ ) with relatively consistent quantity distribution of debitage down through the profile, except for a peak in frequency at the 10 to 20 cmbs level ( $N = 50$ ) and a considerable drop in its lowest level ( $N = 9$ ) between 60 and 70 cmbs (see Table 10-1).

Test Unit 8 yielded moderate to high overall debitage counts ( $N = 252$ ) with a high peak in frequency in the 10 to 20 cmbs level ( $N = 93$ ) that decreased rapidly with depth (see Table 10-1). TU 9 revealed a similar vertical distribution with considerably less total debitage ( $N = 67$ ), but a peak in the 10 to 20 cmbs ( $N = 23$ ), level (see Table 10-1). Test Unit 11 revealed a moderate overall frequency ( $N = 273$ ), with a moderate peak at 10 to 20 cmbs ( $N = 55$ ), and a high peak between 30 and 50 cmbs ( $N = 144$ ) (see Table 10-1).

In the high  $T_2$  terrace, non-Edwards chert is present in most levels. Some upper levels had as much as 46 percent non-Edwards debitage, with much lower percentages in most lower levels. Below roughly 50 cmbs, surficial calcium carbonate adheres to over 50 percent of the debitage, indicative of leaching of minerals down through the profile and long-term relative saturation of the soil. UV analysis of the grab sample of lag gravels from the adjacent uplands reveals roughly 60 percent fluorescence similar to Edwards chert. This indicates that Edwards chert is available in the vicinity of the site.

### ***Beveled Edge***

Along the beveled edge of the high terrace, TUs 3 and 7, excavated to specifically target Feature 1,

yielded relatively low to moderate counts of lithic debitage ( $N = 27$  and  $94$  respectively). A definite peak in frequency ( $N = 63$ ) occurred at the 20 to 30 cmbs level in TU 7. Lacking diagnostic artifacts and radiocarbon dates this feature and associated debitage was not assigned to a specific time period.

### **10.4.1.2 Lithic Debitage Analysis**

Within the broader site assemblage, three distinct components were identified: the probable Toyah, probable Gower, and Late Archaic (see Table 10-1). Reflective of the complex stratigraphic topography of the site, vertical position for each component references the depth below surface (bs) of the respective terrace and unit locale. The probable Protohistoric Toyah component and probable Gower Early Archaic component were in the lower  $T_0$  terrace, whereas the Late Archaic component sample was in the upper  $T_2$  terrace.

The probable Toyah component ( $N = 13$ ) accounts for less than one percent of the total site debitage. The probable Gower Early Archaic component ( $N = 60$ ) is approximately 3 percent of the total site debitage. The selected Late Archaic sample ( $N = 357$ ) is the largest proportion, at approximately 17 percent of the total site debitage.

Lithic debitage associated with these three components ( $N = 430$  cumulatively) was judgmentally selected as the sample chosen for analysis.

### ***Probable Toyah Component***

The probable Toyah component ( $N = 13$ , 3 percent of component-associated) was encountered between 20 and 40 cmbs of adjacent TUs 1 and 2 of the lower  $T_0$  terrace (Figure 10-13). This likely association is based on the Perdiz projectile point (#13-10) from Level 3 (20 to 30 cmbs) in TU2 and radiocarbon dates on charcoal recovered from just beneath.

This small concentration consists of platform-bearing flakes and distal flake

fragments/shatter/angular debris (Figure 10-13). Non-Edwards chert composes the largest group of lithic material with 62 percent ( $N = 8$ ). Twenty-three percent ( $N = 3$ ) was Edwards chert (specifically a grayish-tan), likely collected from local drainages and uplands. In addition, one piece of orthoquartzite (8 percent) was present.

The 13 pieces were relatively evenly distributed among the size ranges with four less 6.4 mm, four between 6.4 and 12.8 mm, and five between 12.8 and 19.2 mm (Figure 10-14). These flake sizes indicate mid- to late-stage reduction and possibly tool finishing/resharpening activities rather than early reduction stages.

Only one chert flake showed evidence of thermal alteration (8 percent) and damage including potlidding (saucer shaped divots) and thermal breaks, likely the result of unintentional heating after discard. Purposeful and/or intentional heating of raw material to improve quality for knapping would have involved controlled heating, and removal from the heat source before such detrimental alterations could occur.

Five platform-bearing flakes are present in the assemblage, constituting 38 percent of the Toyah debitage assemblage. They are relatively evenly distributed between cortical ( $N = 1$ ), flat ( $N = 2$ ), and multifaceted ( $N = 2$ ) platform types. Unfortunately, too few specimens are present within the Toyah debitage to examine which reduction activities (core or bifacial reduction) were dominant at this location. Dorsal cortex was present on 23 percent and exhibited three different frequencies ranges (1 to 25, 26 to 50, and 51 to 75 percent groupings). The presence of a cortical platform indicates some pieces were removals from cortexed covered targets. The Toyah debitage assemblage indicates a reduction/resharpening episode.

In summary, the probable Toyah component lithic debitage in TUs 1 and 2, Levels 3 and 4 (20 to 40

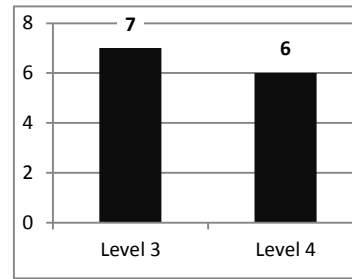


Figure 10-13. Frequency for lithic debitage from Toyah component, TUs 1 and 2, Levels 3 to 4 (20-40 cmbs).

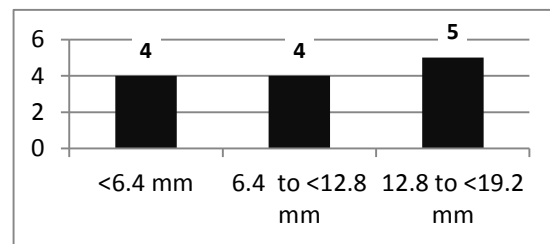


Figure 10-14. Size distribution of Toyah component lithic debitage.

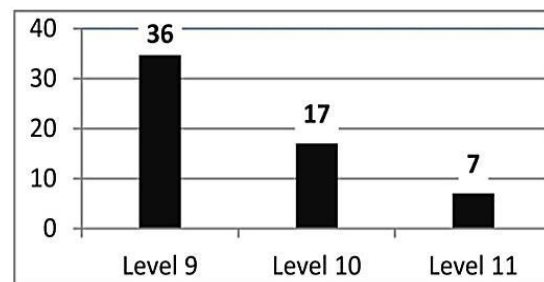


Figure 10-15. Frequency for lithic debitage from 41LM51 Gower component in TUs 1 and 2, Levels 9, through 11 (80 to 110 cmbs).

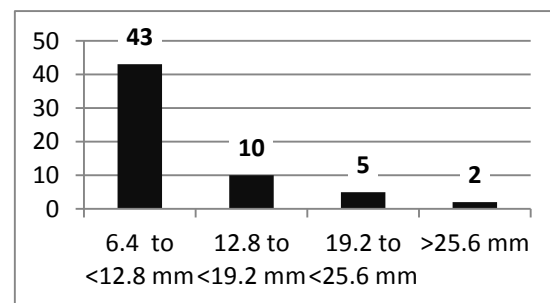


Figure 10-16. Size grade frequency distribution of Gower component lithic debitage at 41LM51.

cmbs), indicates utilization of non-Edwards chert, local Edwards chert, and orthoquartzite raw material, reduction of raw materials and tool production. The limited incidence of cortex on platform-bearing flakes indicates some initial reduction may have occurred, likely from local sources including uplands or nearby stream gravels, such as Lynch Creek along the southern edge of the site.

The restricted incidence of thermal alteration (one piece of non-Edwards chert) and the nature of that alteration (thermal breakage/potlidding) indicates discard of debitage into heating features, rather than intentional heat treatment.

With few platform-bearing flakes in this assemblage, it is difficult to provide interpretations concerning reduction strategies. However, the presence of multifaceted platforms on flakes supports the assertion that bifacial reduction occurred on-site. Core reduction may also have been performed on-site for flake production given that two platform-bearing flakes with only single facets were present.

### ***Probable Gower Component***

The concentration of lithic debitage ( $N = 60$ ; 14 percent) recovered from the lower  $T_0$  terrace in TUs 1 and 2 between 80 and 110 cmbs, Levels 9 through 11, was associated with a Gower projectile point and are attributed to the Early Archaic Gower component. A fragmented Gower projectile point (#19-10) was from Level 9 (80 to 90 cmbs) in TU 2.

Approximately 60 percent ( $N = 36$ ) of the probable Gower debitage assemblage was present in Level 9 (80 to 90 cmbs, Figure 10-15). The group consists of platform-bearing flakes, distal flake fragments/shatter/angular debris. Fifty-five percent ( $N = 33$ ) of the Gower debitage assemblage was composed of Edwards Plateau chert (specifically a grayish-tan). Within this type, five sub-varieties were observed. These include cherts with dark and

light gray specks, white inclusions, dark and light bands, banded with tiny dark spots, and no inclusions. It is likely that all these varieties were collected from local drainages and uplands. Non-Edwards chert composes the second largest group with 28 percent ( $N = 17$ ). Many specimens in this group were dark brown in color and fine-grained. Smaller groups of materials types present include ortho- and meta-quartzite ( $N = 4$ , 7 percent); chalcedony ( $N = 4$ , 7 percent) and unidentified sedimentary rock ( $N = 2$ , 3 percent).

The majority of the debitage assemblage ( $N = 43$ , 72 percent) falls within the 6.4 to 12.8 mm size range (Figure 10-16). The second largest group is between 12.8 and 19 mm range ( $N = 10$ ; 17 percent).

Larger sized debitage are less frequent; between 19.2 and 25.6 mm ( $N = 5$ ) at 8 percent and those greater than 25.6 mm ( $N = 2$ ) at 3 percent. This high proportion of small to midsized flakes indicates an emphasis on mid-to-late-stages of tool production, and perhaps predominately off-site initial stages of reduction of raw materials at procurement locales.

Only one platform-bearing flake had evidence of thermal alteration in the form of thermal breaks. These detrimental alterations indicate that heating likely occurred unintentionally, after discard. Purposeful and/or intentional heating of raw material to improve quality for knapping would have involved controlled heating, and removal from the heat source before such detrimental alterations could occur. Thirty-two platform-bearing flakes are present in the assemblage constituting 53 percent of the Gower debitage in excavation Levels 3 and 4 (Figure 10-17). Of these, 53 percent exhibit multifaceted platforms ( $N = 17$ ). Multifaceted flakes occur from more intensively modified objective pieces (e.g., bifaces or cores with prepared platforms).

Crushed platforms ( $N = 8$ ), often associated with hard-hammer percussion, are the second most

frequent type, representing 25 percent of the platform-bearing assemblage. Flat platforms ( $N = 6$ ) comprise 19 percent of the recognized platforms. Flakes with flat platforms are predominantly detached from nonbifacial tools or planar, unmodified core surfaces (Andrefsky 1998:94; Whittaker and Kaldahl 2001:54). Only one platform-bearing flake is cortical (3 percent), representing initial flake detachment from a cortex-covered objective piece (e.g., a rounded river cobble).

The low occurrence of cortical platforms, the lack of debitage exhibiting cortex on the dorsal face, as well as the higher incidence of smaller flakes, all indicate that early-stage reduction of objective pieces likely occurred predominately off-site. The knapping of raw material within the Gower component appears to have focused primarily on later stages of tool production and reduction.

In summary, the lithic debitage associated with the probable Gower component is comprised of multiple types of raw materials, including Edwards and non-Edwards cherts, ortho- and meta-quartzite, chalcedony, and unidentified sedimentary materials. The single thermally altered flake (Edwards chert) recovered likely represents the discard of lithic debitage into heating features, and indicates intentional heat treatment was not a necessary precursor to material reduction/use.

Although raw materials were readily available in the adjacent uplands and along the streams, evidence indicates predominately off-site initial reduction. The large proportion of platform-bearing flakes with two or more facets, and predominance of smaller to midsized flakes, indicates mid- to late-stages of tool production were the primary source of flakes produced on-site. Limited core reduction is suggested by the presence of low numbers of

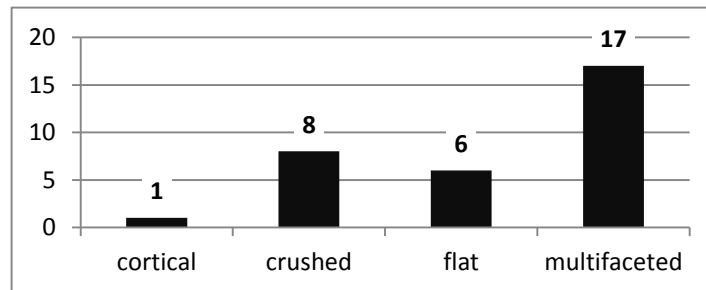


Figure 10-17. Platform types in 41LM51 Gower component debitage assemblage.

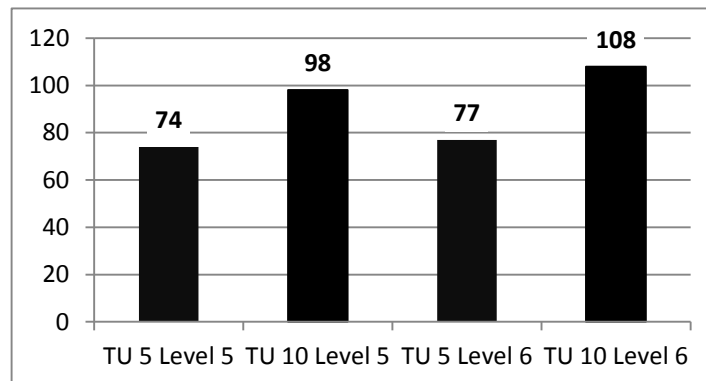


Figure 10-18. Frequency for Late Archaic sample of debitage from 41LM51, TUs 5 and 10, Levels 5 and 6 (40 to 60 cmbs).

platform-bearing flakes with only a single facet. Evidence suggests both bifacial tools and cores were reduced on-site, although what proportion of bifacial reduction flakes may have originated from bifacial cores as opposed to modification of large flakes is unclear.

### **Late Archaic Component**

A sample of the Late Archaic component assemblage was selected for analysis. This sample consisted of a concentration of lithic debitage ( $N = 357$ ) from the upper T<sub>2</sub> terrace in TUs 5 and 10 between 40 and 60 cmbs, Levels 5 and 6 (Figure 10-18). This association was based on the Lange projectile point (#89-10) recovered from TU 10, Level 6 (50 to 60 cmbs) and radiocarbon dates. This group consists of both platform-bearing flakes as well as distal flake fragments (shatter/angular debris).

Non-Edwards chert is the largest group of lithic material with 73 percent ( $N = 260$ ) of the sampled debitage assemblage. Many specimens in this group are fossiliferous or have inclusions (see Figure 9-10), with material colors ranging from black to light tan. Within this type, subgroups of materials include orthoquartzite ( $N = 23$ , 6 percent) and chalcedony ( $N = 3$ , 1 percent). Twenty percent ( $N = 71$ ) of the sampled debitage assemblage was Edwards Plateau chert (specifically a grayish-tan). Within this type, six sub-varieties were observed

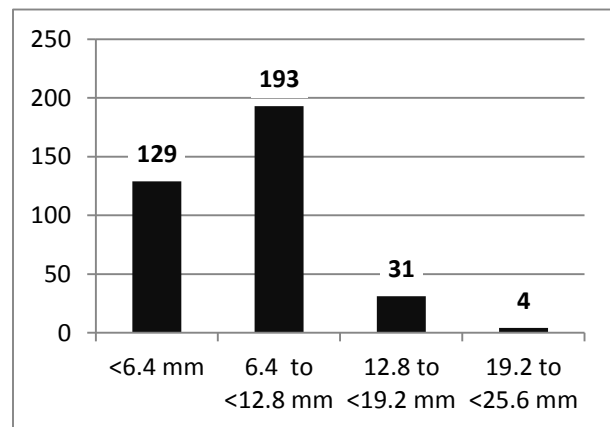
These include cherts with; tiny dark dendrites, dark and light gray specks, white inclusions, dark and light bands, banded with tiny dark spots, and no inclusions. It is likely all varieties were collected from local drainages and uplands.

The majority of the sampled Late Archaic debitage ( $N = 193$ , 54 percent) falls between 6.4 and 12.8 mm size range (Figure 10-19). The second largest group is less than 6.4 mm range group ( $N = 129$ , 36 percent) with the next most abundant size between 12.8 and 19 mm at 9 percent ( $N = 31$ ). The larger pieces, between 19.2 and 25.6 mm, are the least

frequent ( $N = 4$ , 1 percent). This high proportion of small to mid-size flakes is indicative of later stages of tool production and thinning, and perhaps removal of larger flakes for use as informal tools (i.e., modified flakes). There are 167 platform-bearing flakes in the assemblage (Figure 10-20). Of these, approximately 61 percent exhibit multifaceted platforms ( $N = 102$ ). These flakes originate from more intensively modified objective pieces (i.e., bifaces or cores with prepared platforms).

Flat striking platforms ( $N = 30$ ) are the second most frequent type, representing 18 percent of the platform-bearing assemblage. Flat platform flakes are predominantly detached from nonbifacial tools or planar, unmodified core surfaces (Andrefsky 1998:94; Whittaker and Kaldahl 2001:54). Crushed platforms ( $N = 25$ , 15 percent) are often created when hard-hammer percussion is used. Approximately 6 percent of the platform-bearing flakes are cortical ( $N = 10$ ), representing initial flake detachment from a cortex-covered objective piece (e.g., a rounded river cobble).

As with cortical platforms, lithic debitage exhibiting cortex on the dorsal face signifies early-stage reduction of objective pieces (Figure 10-21). A small proportion of platform-bearing flakes



**Figure 10-19. Size distribution of Late Archaic component lithic debitage sample at 41LM51.**



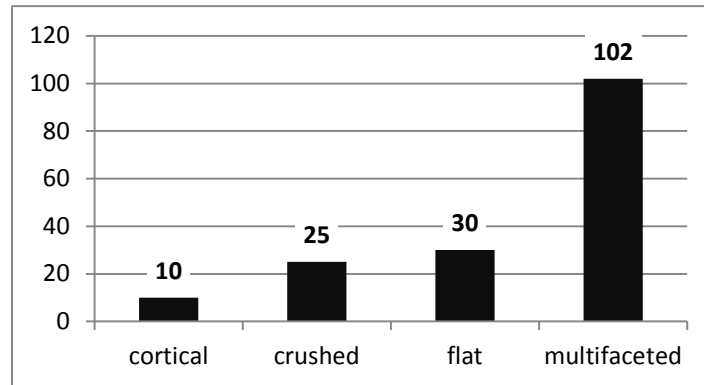


Figure 10-20. Frequency of platform types in the sampled Late Archaic component debitage at 41LM51.

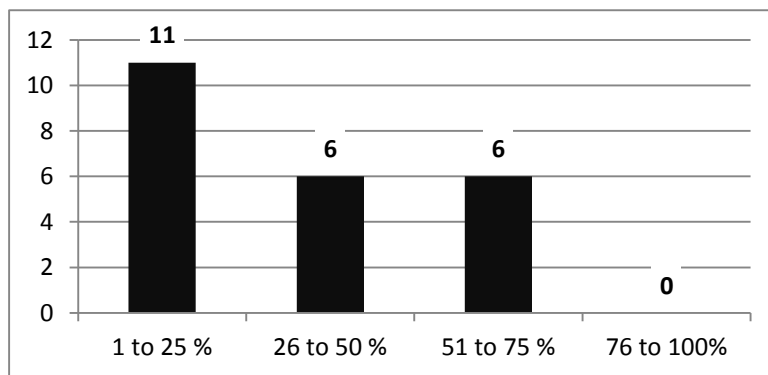


Figure 10-21. Cortex on Late Archaic platform-bearing debitage sampled from 41LM51.

(N = 23, 14 percent) exhibit cortex. This supports the hypothesis that some initial reduction of raw material packages occurred on-site. Therefore, this sample appears to include both limited early-stage cobble reduction along with the major activities of later-stage tool production and reduction.

Thermal alteration of chert has a fairly low representation among platform-bearing flakes (N = 10, 3 percent). The most obvious thermal alteration occurs in the form of potlid marks (saucer shaped divots) and thermal breaks. These alterations suggest that heating occurred unintentionally, after discard. Purposeful and/or intentional heating of raw material to improve quality for knapping of cryptocrystalline silicates (Whittaker 1994:72), is not evident in this assemblage, and would have involved removal from the heat source before such detrimental alterations could occur.

In summary, the sampled lithic debitage from TUs 5 and 10, Levels 5 and 6 (40 to 60 cmbs) associated with the Late Archaic component, reveals primarily utilization of non-Edwards and local Edwards chert, as well as small incidences of orthoquartzite and chalcedony; reduction of cortex-covered raw materials, and bifacial/flake tool production. The low occurrence of cortex on platform-bearing flakes indicates limited on-site initial reduction of raw materials. Raw material sources were most likely procured locally from uplands or gravels associated with nearby streams such as Lynch Creek along the southern edge of the site.

The relatively restricted incidence of thermal alteration and the nature of that alteration (potlidding and thermal breakage) indicate that the heating of lithic material was not a necessary

precursor to material reduction/use. The heat-altered debitage likely represents discard of chert debitage into hot heating features. As a result, it does not appear the site occupants employed intentional heat treatment in the lithic reduction process.

The high proportion of smaller sized flakes, as well as platform-bearing flakes with two or more facets indicates bifacial thinning, edge finishing, and rejuvenation were the primary source of the flakes produced at this locality. Core reduction is also indicated by the limited presence of dorsal cortex, cortical flakes, and platform-bearing flakes with only a single facet. Therefore, although bifacial tools and cores were reduced in this component, it is unclear what proportion of bifacial reduction flakes originated from bifacial cores as opposed to modification of large flakes.

#### **10.4.2 Chipped Stone Tools**

The 10.3 m<sup>3</sup> total hand-excavations yielded a total of 119 formal and informal stone tools for an average of slightly less than 1 tool per 10 cm level. The tools include 9 projectile points and point fragments, 95 edge-modified flakes, 12 bifaces, 1 gouge, and 1 scraper. The 4.8 m<sup>3</sup> excavated into the high T<sub>2</sub> terrace yielded the highest density of chipped stone tools, accounting for 95 percent of the total tools. In contrast, the low T<sub>0</sub> terrace yielded only four percent, but those few tools recovered were from two well-defined and stratigraphically separated components.

The 9 projectile points include 1 unidentifiable barb fragment (#99-10), 1 unclassified stem base (#69-10) and 7 identifiable point fragments. The latter include a complete Perdiz arrow point (#13-10), a broken Frio (#104-10), a Marcos base (#52-10), a broken Gower (#19-10), one complete Lange (#89-10), and two questionable Pedernales base/stem fragments (#79-10 and #82-10).

The 2.6 m<sup>3</sup> excavated in the lower T<sub>0</sub> terrace (TUs 1 and 2) yielded one complete Perdiz point from 20 to 30 cmbs, well-separated stratigraphically from the broken Gower point from between 80 and 90 cmbs in TUs 1 and 2 (Figure 10-22). Both points appear associated with other cultural materials, which document stratigraphically isolated components. Also both points exhibit a yellow UV fluorescence that indicates both were made from Edwards chert.

The remaining 7 dart points came from the high T<sub>2</sub> terrace and scattered throughout the upper 70 cmbs. The Frio and Marcos came from 45 to 55 cmbs in TU 10 and 35 cmbs in TU 5 (Figure 10-23). The complete Lange was slightly below the latter two points at 59 cmbs in TU 10. This point exhibits calcium carbonate across one pot-lidded face. TU 9 yielded the two questionable Pedernales point base fragments from 10 to 20 and 50 cmbs (Figure 10-24). On the basis of UV fluorescence, only the Lange point appears manufactured from non-Edwards chert, whereas other points appear manufactured from Edwards chert. These five dart points represent a restricted time period of roughly 1,500 years, between ca. 1500 and 3000 B.P., within the Late Archaic period (Prewitt 1985).

None of the 12 bifaces are complete with three small sections (#52-11, #87-10, and #85-11) that might be point fragments (see Figure 10-24). A single proximal biface fragment (#51-10) appears heat-treated as it exhibits a high glossy luster. Five fragments exhibit some calcium carbonate on one surface. All five are non-Edwards chert based on UV fluorescence (Figure 10-25).

Four biface fragments (#51-10, #69-11, #83-10 and #89-12) from the T<sub>2</sub> terrace were subjected to high-powered microscopic use-wear. Briefly, Hardy observed soft polish on two with hard/high silica polish on the other. Organic residues in the form of hair and wood were on two bifaces. All three served as scraping tools (Appendix C).

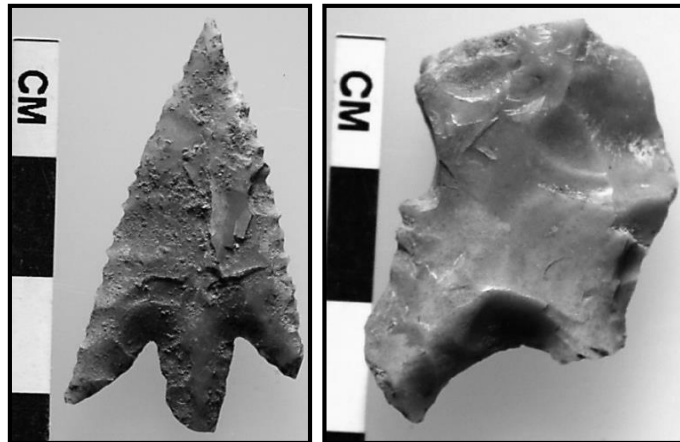


Figure 10-22. Unwashed Perdiz (#13-10, left) and Gower (#19-10, right) point from low T<sub>0</sub> terrace at 41LM51.

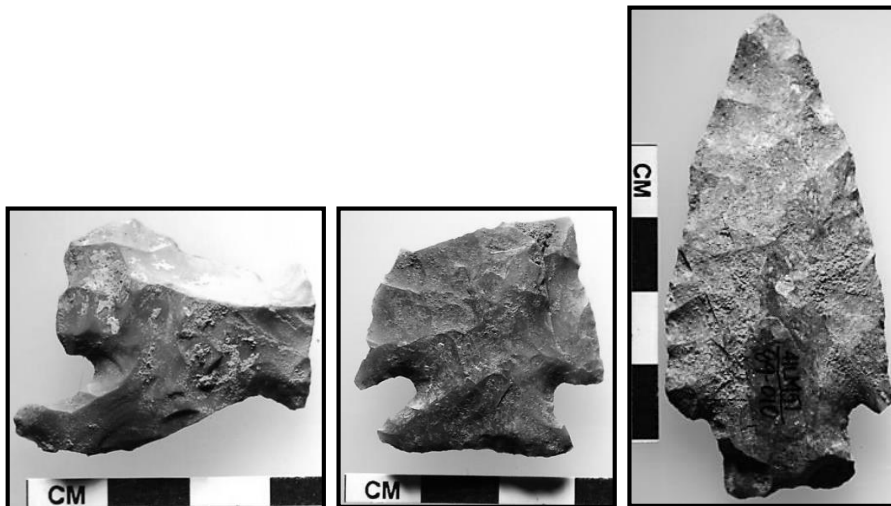


Figure 10-23. From left to right, unwashed Frio (#104-10), unwashed Marcos (#52-10), and unwashed Lange (#89-10) dart points from upper T<sub>2</sub> terrace at 41LM51



Figure 10-24. Dart point bases from upper T<sub>2</sub> terrace at 41LM51, unwashed and untyped (#52-11 and #69-10) and unwashed Pedernales base (#79-10).

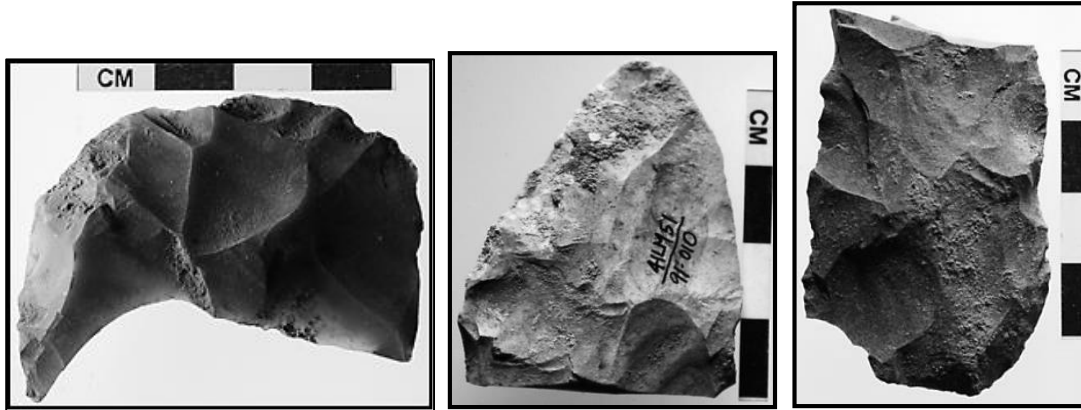


Figure 10-25. Unwashed biface fragments from Late Archaic component in T<sub>2</sub> terrace at 41LM51 (#81-10, #91-10 and #59-10) used in starch grain analysis.

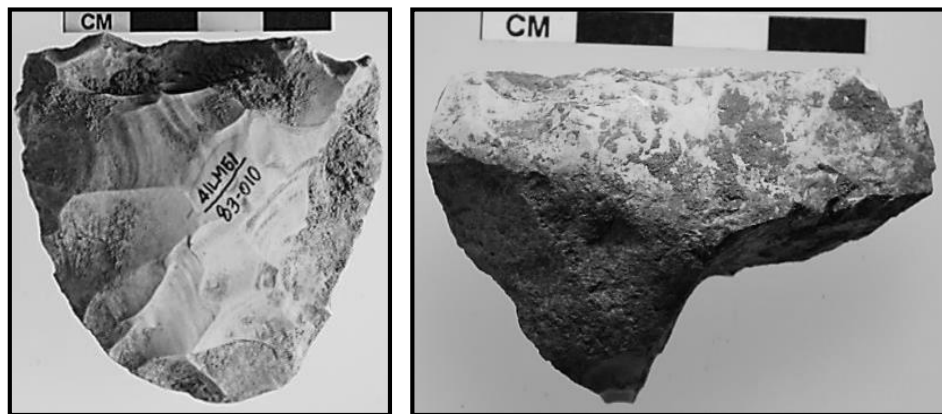


Figure 10-26. Unwashed gouge (#83-10) and unwashed side scraper (#66-10) from upper T<sub>2</sub> terrace at 41LM51.

A gouge (#83-10) was recovered from 55 cmbs in TU 9 and the same depth as the Pedernales point (#82-10). This gouge is not typical in overall form, since it lacks a steep beveled distal end and is relatively thin and broad similar to a thin biface (Figure 10-26). The distal end is worked, but this possibly was worked from a break facet as the flake scars were not well-executed or well-patterned. The very proximal edge is lightly rounded and worn. One face is completely white indicating it is patinated. The opposite face is partially patinated. This patination indicates this artifact was on surface for sometime. High-powered use-wear revealed wood and collagen residues, but lacked polish, which is interpreted to indicate the cutting of wood and possibly hide (Appendix C).

A single tool is classified as a scraper, which came from 18 cmbs in TU 7. This side scraper (#66-10) was manufactured from a primary flake of chert that reveals cortex on about half the dorsal surface and a flat ventral surface (see Figure 10-26). One steep and scoured lateral edge was potentially created during use as the flake scars are not well-patterned. The distal end exhibits a large scar that may reflect rejuvenation at that end. This specimen was subjected to both high-power microscopic use-wear and starch grain analyses. The use-wear observed wood and plant fibers in conjunction with hard/high silica polish, striae, and edge rounding. These characteristics indicate it was used for scraping wood (Appendix C). Perry recovered no starch grain on this tool (Appendix D).

The 95 edge-modified flakes presumably reflect both cutting and scraping motions. These diverse pieces were primarily from the T<sub>2</sub> terrace with one each in with the Toyah and Gower components in the T<sub>0</sub> terrace.

Sixteen edge-modified flakes were subjected to high-powered microscopic use-wear analyses. Fourteen were from the T<sub>2</sub> terrace (the Late Archaic component) and two from the T<sub>0</sub> terrace. In summary, Hardy observed residues (plant fibers and tissues, hair, collagen, raphides, and red staining) on 11 specimens (Appendix C).

Actual use-wear, both soft ( $N = 5$ ) and hard/high silica polish ( $N = 7$ ), striae ( $N = 6$ ), microflake scars ( $N = 3$ ), and edge rounding ( $N = 1$ ) were present on 15 of the 16 specimens. These edge-modified flakes reflect multiple functions that include cutting ( $N = 10$ ) and scraping ( $N = 2$ ) on soft materials, plants, and hard substances such as wood and possibly mineral (Appendix C).

Two edge-modified flakes (#91-12 and #103-10) were sent for starch grain analysis. Unwashed edge-modified flake #91-12 from 70 to 80 cmbs in TU 10 that represents the Late Archaic component yielded a gelatinized starch grain that was unidentifiable (Appendix D).

#### 10.4.3 Faunal Remains

Vertebrate faunal remains were nearly absent from the 10.3 m<sup>3</sup> total hand-excavations. Only 17 bone fragments, weighing 19.0 g cumulatively, were recovered (Table 10-2). The largest piece (#48-002-1) represents a section of long bone from a deer-size mammal and was recovered from 100 to 112 cmbs in the wall of TU 4. This fragment accounts for nearly 77 percent of the total weight of all faunal materials recovered. This bone was an isolated occurrence not associated with any identified cultural material, and likely represents a natural inclusion within the low alluvial deposits. Fifteen

tiny fragments were all from the top 20 cm of the deposits in the upper terrace. None of the 15 pieces are burned or otherwise culturally modified, and therefore are suspect as representing cultural remains. Likely these shallowly buried pieces are intrusive into the prehistoric occupations. One small piece (#65-002-1) from TU 7 is a fresh, modern looking fish bone.

Only one tiny calcined bone fragment (#98-002-1) was recovered, and it came from between 50 and 60 cmbs in TU 11. The lack of animal bones, especially from the Toyah component in the low terrace, likely indicates very poor bone preservation. It is also possible absence of faunal remains indicates increased human exploitation of plant resources at this locality or poor preservation in this sandy context. It may also indicate a very short-term camp in which animal resources were not exploited and use of stored products.

Likely these shallowly buried pieces are intrusive into the prehistoric occupations. One small piece (#65-002-1) from TU 7, a possible fish bone has a fresh appearance.

#### 10.4.4 Mussel Shells

The 10.3 m<sup>3</sup> hand-excavations yielded only 19 small mussel shell fragments (see Table 10-2). Two small unidentifiable pieces were recovered from the low T<sub>0</sub> terrace in TUs 1 and 2, one between 50 and 60 cmbs, and the other between 80 to 90 cmbs. The latter fragment was within the Gower component. The remaining 17 pieces came from across the high T<sub>2</sub> terrace and include nine umbos with only four to five valve sections that are sufficiently intact for identification. The identifiable shells include two smooth pimpleback (*Quadrula houstonensis*; #71-6-1 and #75-6-1), one pistolgrip (*Tritogonia verrucosa*; #88-6-1), and one or two lilliput (*Toxolasma parvus*; #72-6-1 and #72-6-2). These three species were common in the greater central Texas streams and rivers in historic

**Table 10-2. Material Summary by Test Unit for 41LM51.**

Material Classes	Test Units by Land Form											Unit Totals
	Lower T <sub>0</sub> Terrace			Beveled Edge		Upper T <sub>2</sub> Terrace						
	1	2	4	3	7	5	6	8	9	10	11	
<b>Projectile Points</b>	0	2	0	0	0	1	0	1	2	2	1	9
<b>Stone Tools</b>	3	0	0	0	1	5	9	9	11	34	7	79
<b>Lithic Debitage</b>	38	63	3	27	94	472	157	252	67	632	273	2078
<b>Mussel Shells</b>	1	1	0	0	0	2	0	7	1	3	4	19
<b>Charcoal</b>	P	P	P								P	
<b>Feature Nos.</b>		2		1						3, 4		4
<b>Burned Rocks</b>	89	114	0	17	28	130	45	200	32	177	36	868
<b>Bone Fragments</b>	0	0	3	0	1	0	0	5	0	0	8	17
<b>Snail Shells</b>	20	63	110	43	13	67	11	62	12	71	49	521
<b>Total Counts</b>	151	245	116	88	137	677	222	536	125	940	378	3595
<b>Total Area m<sup>3</sup></b>	1.0	1.5	2.0	0.4	0.4	0.9	0.7	0.9	0.7	0.9	0.7	10.3

P = present; Total counts do not include charcoal or sediment samples

times (Howells et al. 1996). No mussel shells were directly associated with the two features. The shells were widely distributed horizontally within five test units (see Table 10-2). They were also vertically distributed from about 10 to 90 cmbs, with about 70 percent of the count from between 20 and 60 cmbs. Those latter shells were mixed in with the other cultural materials present in those same levels. None of the pieces were culturally modified, such as fashioned into tools or ornaments. However, one tiny tooth fragment (#97-6-1) from 50 to 60 cmbs in TU 11 is a dark gray color, indicating contact with heat, either indirect or direct. Mussels probably did not provide a significant food resource at any of the occupations at 41LM51.

#### 10.4.5 Charcoal

In the field, several tiny black, seemingly charcoal pieces were observed and collected. However, close inspection in the laboratory revealed that nearly all that black material was actually a soft dark shale or coal, rather than charcoal. These black pieces

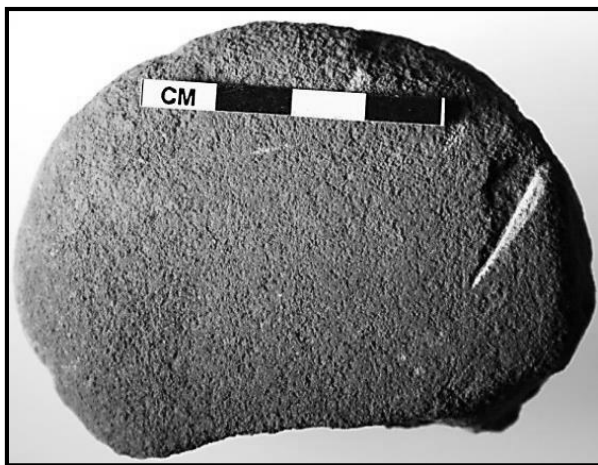
exhibit smoothed and rounded edges indicating rounding from water transportation.

A few tiny pieces of scattered charcoal were observed primarily in the top 20 cmbs of the excavations, however, the presence of burned trees on-site and the shallow depth of the charcoal, these scattered pieces were of questionable origin. No charcoal was directly associated with the four identified cultural features, even after floating sediment samples collected from amidst and below the burned rocks in Features 2 through 4. In the low terrace, scattered charcoal pieces were collected from the top 40 cmbs. Several charcoal samples were identified by Dr. Dering, and are reported in Appendix H. Two charcoal samples (#2-7-1 and #2-7-2) from 10 to 20 cmbs in TU 1 yielded identifiable woods that include Mexican peach, buckeye, and juniper wood. Another charcoal sample from about the same level (23 cmbs in TU 2) was identified as oak wood and also radiocarbon dated (#13-7-1). A slightly lower sample (#4-7), from 30 to 40 cmbs in TU 1, was

identified as part of the hickory family, whereas a piece of charcoal (#14-7-7) from 30 to 40 cmbs in TU 2 was identified as oak. These diverse woods from the upper part of the profile indicate human utilization rather than natural intrusions. Also in the low terrace, a piece of charcoal from 170 to 180 cmbs in TU 4 (#45-7) was identified as part of the Rosaceae sp. (Crabapple/peach, Appendix H). The high terrace yielded almost no charcoal. A high terrace sample (#94-7) from 10 to 20 cmbs in TU 11 included sycamore and oak. The very low occurrence of charcoal within the cultural context and identified features likely reflects generally poor on-site preservation in acid rich soils.

#### 10.4.6 Ground Stone Tools

A single ground stone tool, a small (232 g) one-handed mano (#59-11), was recovered from 24 cmbs in TU 6. This is a roundish sandstone piece with a biplano longitudinal cross section that measures about 8 cm in diameter and nearly 3.0 cm in thickness. It has calcium carbonate covering most of one face, whereas the other face exhibits a slight polish and is nearly flat or slightly convex (Figure 10-27). The light polish and the lack of any sign of rejuvenation indicates this mano was not used extensively and may have had a very short



**Figure 10-27. Unwashed mano (#59-11) from 24 cmbs in TU 6 at 41LM51.**

use-life. Several small crushed areas are present along the lateral edges, but it is not clear if these were caused by use or were present from the original stone. This mano was sent for starch analysis, but no starch grains were recovered (Appendix D).

Specimen #103-10, a washed flake from Feature 3 in the Gower component did not yield any starch (Appendix D).

#### 10.4.7 Snail Shells

The 10.3 m<sup>3</sup> total hand-excavations yielded 521 small snail shells cumulatively, generally consisting of at least three species: *Rabdotus*, *Helicinidae*, and *Polygyridae*. About 83 shells (nearly 16 percent) were scattered vertically in TUs 1 and 2 in the low terrace (see Table 10-2). A higher frequency seemed to occur within the Toyah component. Three *Rabdotus* shells (#19-6a) from 80 to 90 cmbs in TU 2 (about the same level as Feature 2) were radiocarbon dated. Also in the low terrace, TU 4 yielded roughly 110 shells (21 percent of the total from this terrace) scattered vertically with depths ranging from near the surface to 180 cmbs.

The lowest 40 cm of the excavated levels, between 140 and 180 cmbs, yielded 71 percent from this low terrace. TU 4 yielded only 3 tiny pieces of chert of questionable origin.

The eight test units on the high terrace yielded 328 shells cumulatively that were widely dispersed both vertically and horizontally. Three samples of *Rabdotus* shells (#52-6a, #55-6a, and #56-6a) from three arbitrary levels in TU 5 (30 to 40 cmbs; 60 to 70 cmbs; and 70 to 80 cmbs, respectively) were selected for radiocarbon dating. One sample of *Rabdotus* shells (#89-6a) from 50 to 60 cmbs in TU 10 (the same level as Feature 4, near the Frio point) was radiocarbon dated (see Section 10.6 below). None of the shells appeared culturally modified.

### 10.4.8 Burned Rocks

The 10.3 m<sup>3</sup> total hand-excavations yielded roughly 941 burned rocks that weighed 82,901 g cumulatively, for an average of 9 rocks per 10 cm level. The burned rocks were distributed unevenly. Only approximately 15 percent (*N* = 144) were recovered from four burned rock features; however, their weight accounted for nearly 53 percent of the total.

Feature rocks weighed an average of 598 g per rock, compared to the average of 45 g per rock for scattered burned rocks. The discrepancy between the sizes of the much larger burned rocks recovered from within the features compared to the scattered burned rocks. In general, features retain relatively high degree of cultural integrity and represent largely *in situ* intact heating elements or intentional discard localities. Scattered burned rocks may have been discarded prehistorically when deemed too small for further utilization, or perhaps, due to

smaller size, were displaced by subsequent on-site impacts.

Very little difference exists between the average counts from the two terraces (Table 10-3). The burned rocks in TUs 1 and 2 were scattered throughout the profile, but exhibit high peaks in frequency concentrations in the 10 to 30 cmbs and 80 to 110 cmbs ranges. These two vertically separated zones probably represent two stratigraphically distinct components. The TU 4 burned rock pieces (*N* = 17) are exceedingly tiny and probably do not represent significant cultural events and could not be assigned to either component.

The high T<sub>2</sub> terrace revealed variable distributions both vertically and horizontally. TUs 5 and 10 exhibited consistent similar vertical patterning to each other (Table 10-3). The vertical pattern in TUs 5 and 10 reveals a peak in frequency between 40 and 60 cmbs. The frequency above that zone is

**Table 10-3. Vertical and Horizontal Distribution of Burned Rocks at 41LM51.**

Depth (cmbs)	Test Units by Land Form										
	Lower T <sub>0</sub> Terrace			Beveled Edge		Upper T <sub>2</sub> Terrace					
	TU 1	TU 2	TU 4	TU 3	TU 7	TU 5	TU 6	TU 8	TU 9	TU 10	TU 11
0-10	1	1			1	4	0	35	0	0	1
10-20	12	10			17	1	10	76	7	5	2
20-30	15	10		3	10	6	28	61	3	12	2
30-40	10	5	1	26, F1		9	5	18	11	11	11
40-50	4	2	6			29, F4	2	2	8	59, F3 & 4	20
50-60	3	5	4			34	1	3	3	38	
60-70	4	3				17		5		36	
70-80	7	8				14				22	
80-90	18	30, F2	3			16				32	
90-100	15	33	3								
100-110		13									
110-120		0									
120-130		1									
130-140		3									
140-150											
150-160											
160-170											
170-180											
180-190											
190-200											
Totals	89	124	17	29	28	130	46	200	32	215	36

█ = Peak in Frequency; F = Feature No.



considerably less whereas below that zone the frequency was only moderately lower. TU 11 yielded a distinct peak between 40 and 50 cmbs that may represent an occupational surface. A similar peak is present in TU 9, although at a slightly higher elevation. TUs 6, 8, and 9 revealed vertical frequencies that peak above 40 cmbs (Table 10-3). The differences in vertical concentrations between TUs indicate the horizontal differential distributions present across this high terrace probably reflect different activity areas.

## 10.5 CULTURAL STRATIGRAPHY, HORIZONTAL AND VERTICAL DISTRIBUTIONS OF ARTIFACTS

Both the lower T<sub>0</sub> and upper T<sub>2</sub> terraces and the beveled slope between the two terraces revealed cultural materials of different ages, in different contexts, and in various frequencies. The cultural materials contained in these three settings are discussed below and identified in components.

### 10.5.1 The Lower T<sub>0</sub> Terrace

The flat lower T<sub>0</sub> terrace was investigated through hand-excavation of 2.6 m<sup>3</sup> in TUs 1 and 2, to a depth of 180 cmbs. Vertical separation of two relatively well-defined concentrations of cultural materials was exhibited (Figure 10-28). The upper cultural

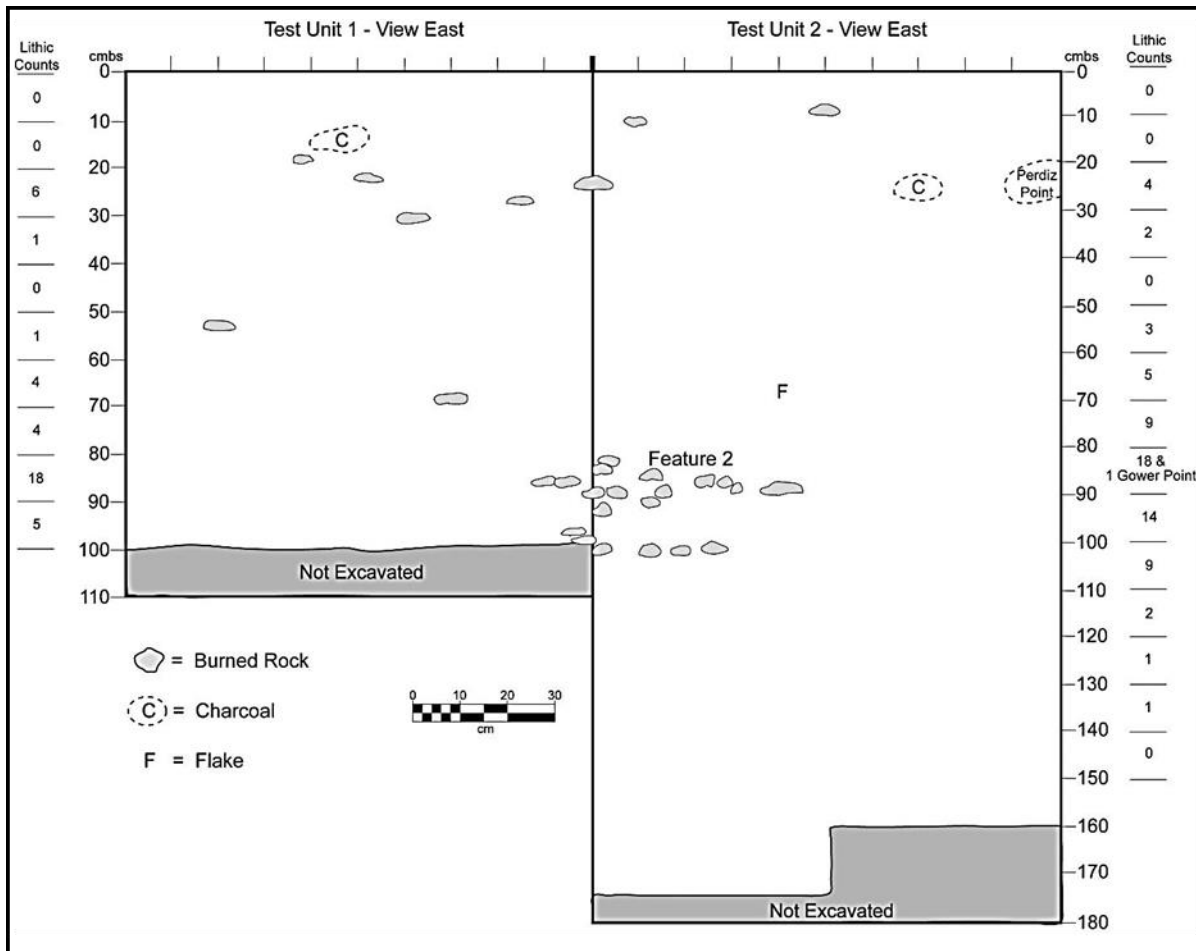
concentration between 10 and 40 cmbs consisted of 13 pieces of lithic debitage, some 61 scattered burned rocks and the occasional chunk of charcoal (see Table 10-3) This reflects a Late Prehistoric to Protohistoric Toyah component on the basis of the complete, well-crafted Perdiz arrow point (#13-10) and associated conventional charcoal date of 130 ± 50 B.P. (UGA-14421) obtained on an oak wood sample (#13-7-1) from a depth of 23 cmbs. A second conventional charcoal date of 290 ± 30 B.P. (Beta-345278) was obtained from charcoal (#4-7) between 30 and 40 cmbs. A third date on organic residue from a burned rock (#3-3-1) from between

20 and 30 cmbs yielded an unaccepted date of 1940 ± 30 B.P. (Table 10-4).

Unless the charcoal was intrusive, those two charcoal dates would indicate a very late occupation period. The charcoal samples did not come from a well-defined cultural feature, and the age ranges are considered potentially too recent for this component, though it is also possible the recent dates do reflect the actual age of the component as a rare Protohistoric event. Although no diagnostically Protohistoric or historic artifacts were recovered, the low frequency of lithic tools from these two test units may lend indirect support for this date range assignment. This component yielded rather restricted frequencies of cultural material, implying a short-term occupation, potentially reflecting a single event, not the high frequencies one would expect from long-term occupation or multiple events. No faunal remains were recovered at this depth.

This Late Prehistoric or potentially Protohistoric Toyah occupation occurs within a thin, about 15 cm thick 2Ab horizon formed in Unit 5a alluvium and situated on colluvial sediment derived from reworking of Unit 2 deposits. The buried soil bearing the Late Prehistoric occupation could not clearly be recognized in the nearby cutbank exposure immediately adjacent to the highway bridge. Many deposits in that exposure appeared of very recent age. Hence, the cutbank was inferred as a wedge of Unit 5b lapped onto a thin core of Unit 5a, within which the Late Prehistoric occupation was situated.

The general setting of this occupation and its potential integrity appear excellent, but it is unclear how extensive the wedge of Unit 5a deposits may be. In a worst-case scenario, a narrow strip (about 3 to 4 m wide by 10 to 15 m long, the length measurement largely determined by the ultimate width of the final right-of-way) of this deposit may be left in the right-of-way. At the best, Unit 5b



**Figure 10-28. Vertical patterning of in situ plotted materials in TUs 1 and 2 at 41LM51. Note: The lithic counts and stone tools by level for the two test units are at either side.**

deposits may extend across much of the T<sub>0</sub> surface and be as much as 10 to 12 m wide.

Between 80 and 110 cmbs, about 40 cm below the upper component, was another concentration. This included some 64 pieces of lithic debitage and 103 burned rocks, some concentrated in Feature 2 and some scattered (see Table 10-3). This reflects an Early Archaic Gower component based on the recovery of a fragmentary Gower point (#19-10) and a composite *Rabdotus* date of 6750 ± 50 B.P. (UGA-14422) (see Table 10-4). Caution is advised in accepting the radiocarbon date at face value because of the material dated. The small *Rabdotus* shells are potentially displaced from their original deposit. The lower Gower component yielded a

higher density of lithic debitage and burned rocks than the upper Toyah component. It also yielded one edge-modified flake (#9-11), but no formal tools other than the Gower point from this 0.6 m<sup>3</sup> zone. The relatively moderate frequencies of both lithic debitage and burned rocks imply minimally two primary activities, one focused on heating/cooking and the other on tool manufacturing.

When compared with the previously established ages for the two associated projectile point types recovered, the two radiocarbon dates from this low T<sub>0</sub> terrace are generally reasonable ‘ballpark’ dates and are stratigraphically consistent. Therefore, the two radiocarbon ages are accepted as approximate

**Table 10-4. Radiocarbon Data and Results from 41LM51.**

Cat. No.	Test Unit No.	Depth (cmbs)	Feature No.	Material Dated	Lab No.	Measured Age	<sup>13</sup> C/ <sup>12</sup> C Ratio (‰)	Conventional Age (B.P.)	2 Sigma Calibration Range
13-7-1	2	23		Charcoal	UGA-14421	150 ± 50	-26.44	130 ± 50	
19-6a	2	80-90		3 <i>Rabdotus</i>	UGA-14422	6510 ± 50	-10.49	6750 ± 50	5730-5550 BC
52-6a	5	30-40		1 <i>Rabdotus</i>	UGA-14423	4600 ± 50	-8.77	4870 ± 50	3770-3520 BC
55-6a	5	60-70		3 <i>Rabdotus</i>	UGA-14424	4910 ± 40	-6.02	5220 ± 40	4220-3950 BC
56-6a	5	70-80		3 <i>Rabdotus</i>	UGA-14425	5520 ± 50	-8.74	5790 ± 50	4780-4500 BC
89-6a	10	50-60		5 <i>Rabdotus</i>	UGA-14426	5590 ± 50	-8.71	5860 ± 50	4850-4550 BC
4-7	1	30-40		Charcoal	Beta-345278	310 ± 30	-26.0	290 ± 30	AD 1500-1660
3-3-1	1	20-30		Burned Rock	Beta-345279	1880 ± 30	-21.5	1940 ± 30	AD 0-130

ages for the two well-separated components in the low terrace.

The Gower component is within the colluvial deposit beneath the wedge of Unit 5a. At first glance this colluvial deposit was similar to Unit 2 because it includes many pedogenic carbonate nodules. But closer inspection of the deposit revealed differences in the appearance of the secondary carbonates specifically variations in the arrangement and the inclusion of fragments. This indicates that they are not in their original context.

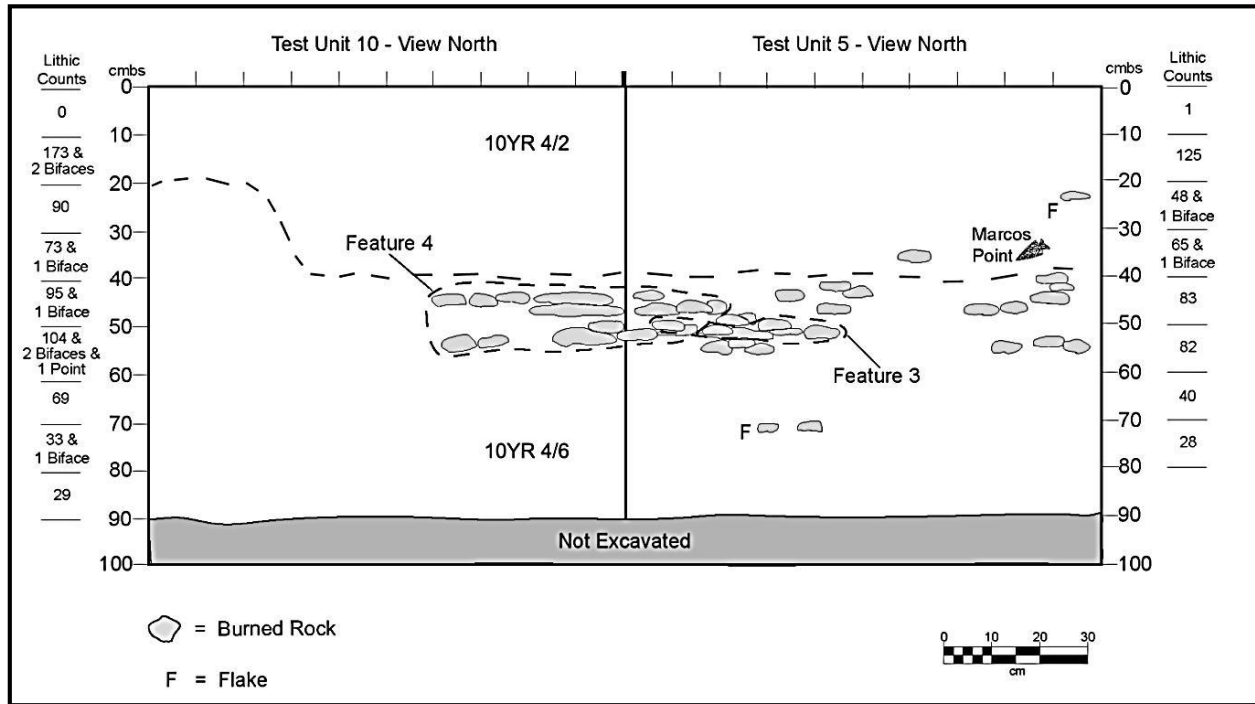
The presence of Feature 2 in this deposit together with other cultural materials indicates that this occupation is essentially intact, despite the reworked colluvial nature of the enveloping sediment. The presence of an Early Archaic occupation in a sheet of colluvium directly on the eroded surface of Unit 2 is also interesting.

It indicates there was either not an early Holocene alluvial deposit forming here at the time, or if there was one, it was of similar size to the modern floodplain, which is quite narrow. The lack or limited nature of early Holocene deposits would account for the lack of cultural deposits of this age

and make the Gower component that much more important.

This Early Archaic Gower component in colluvial deposits beneath the T<sub>0</sub> surface in TUs 1 and 2 probably retains stratigraphic integrity. A time gap exists between the sealing of this deposit by Unit 5 deposition, the occupation, and the subsequent deposition in the late Early Archaic. The degree of pedogenic development seems inconsistent for a deposit that was potentially in place for nearly 5,000 years, unless the colluvial deposit at 41LM51 was previously greater in thickness and has since been truncated by erosion. The intervening 40 cm, from roughly 40 to 80 cmbs, were not completely void of burned rocks or lithic debitage, but their lower frequency was a considerable change compared to the two identified components.

The limited artifacts from the intervening levels might be explained through minor disturbances to the components. However, these artifacts cannot be assigned to one of the identified components. Therefore, this low terrace revealed two well-defined components, roughly 20 to 30 cm thick, stratigraphically well-separated by roughly 40 cm.



**Figure 10-29. Vertical patterning of in situ plotted materials in TUs 5 and 10 at 41LM51.** Note: The lithic counts and stone tools by level for the two units are at either side.

### 10.5.2 High T<sub>2</sub> Terrace

The high T<sub>2</sub> terrace yielded prehistoric cultural materials primarily from approximately 10 to 90 cmbs. TU 8 also yielded burned rocks and lithic debitage in the top 10 cmbs. Scattered, but consistent, historic debris (thin metal fragments, clear glass, and whiteware) dominated the top 10 cmbs across most of this high terrace. Consequently, the upper 10 cmbs is a mixture of recent historic artifacts mixed with prehistoric artifacts.

Multiple prehistoric events appear represented below the top 10 cmbs, in a 70 to 80 cm thick zone that contains minimally two burned rock features (Features 3 and 4) at the same depth between 40 and 50 cmbs (Figure 10-29). Different test units scattered across this upper terrace exhibited different vertical concentrations of material classes, but the excavated arbitrary 10 cm levels nearly always yielded scattered lithic debitage and burned

rocks with no obvious sterile zone(s) between peaks of cultural material (Figure 10-30).

TUs 5 and 10 were side-by-side near the middle of the easement and yielded the highest concentrations of material in two specific vertical zones. The upper cultural zone was between 10 to 20 cmbs and yielded quantities of lithic debitage in frequencies that were much higher than the levels directly above or below this zone. However, this same zone yielded almost no burned rocks (see Table 10-3; Figure 10-30).

The lower zone in TUs 5 and 10 contained a second major peak in lithic debitage that was detected between 40 and 60 cmbs and also contained two burned rock features and peaks in burned rock counts (see Figure 10-30). This roughly 20 cm thick zone also yielded 3 biface fragments and 2 projectile points (Frio and Lange). Although peaks in the vertical distribution of lithic debitage were detected in these two vertically separate zones, the intervening and other levels revealed consistent

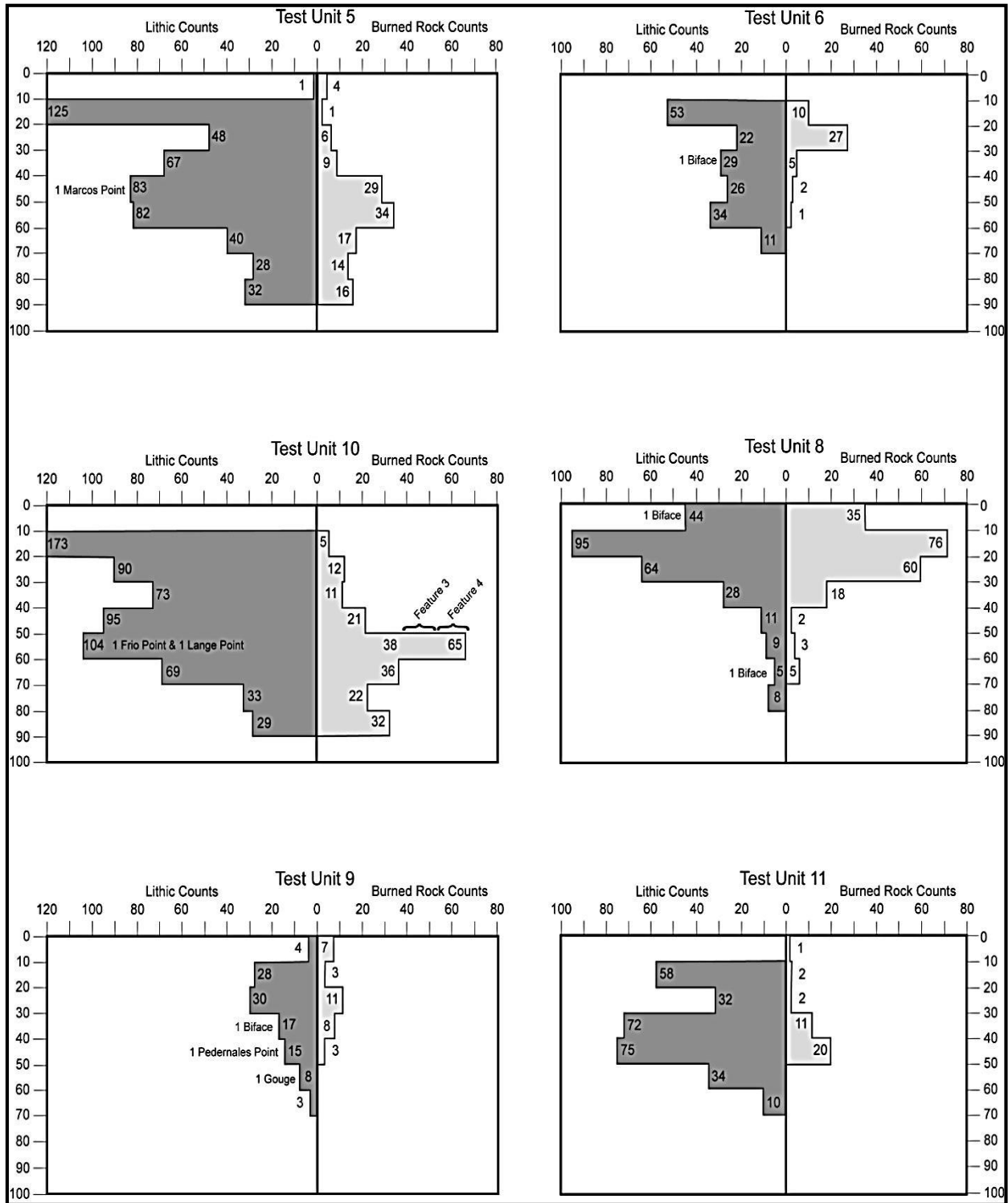


Figure 10-30. Vertical distribution of lithic debitage and burned rocks by selected test units at 41LM51.

presence of artifacts at lower frequencies. The other four test units across this high T<sub>2</sub> terrace (TUs 6, 8, 9, and 11) revealed vertical concentrations of lithic debitage and burned rocks at similar elevations to the two prominent zones detected in TUs 5 and 10 (see Figure 10-30).

Although the quantities are not as dramatic as in TUs 5 and 10, high frequencies of lithic debitage are present in the upper zone (10 to 20 cmbs) of TUs 6, 8, and 9. TU 9 yielded a possible Pedernales base (#79-10) from this upper zone. TU 8 also yielded a high frequency of burned rocks indicating a possible activity area that focused on cooking. The concentration of burned rocks in this upper zone of TU 8 further supports horizontal patterning of classes of material in the upper zone. The lower zone, between 40 and 60 cmbs, detected in TUs 5 and 10 was not as obvious in the other four test units. However, TU 11 yielded a peak count of burned rocks between 40 and 50 cmbs together with moderate counts of lithic debitage. This is the same zone as burned rocks Features 3 and 4. TUs 6, 8, and 9 all yielded very limited numbers of burned rocks and lithic debitage and do not reveal peaks in material frequencies from this lower zone.

Viewed horizontally across this high terrace, different areas contained different concentrations of material classes at different depths reflecting the different uses of this space over time. On the basis of the different types of projectile points represented it appears that multiple camping events occurred across this terrace. However, the absence of arrow points coupled with the occurrence of minimally five Late Archaic dart points indicates the primary use period of the multiple events are of the Late Archaic period. Although individual events cannot be separated here, this upper terrace was occupied over a period of some 1,500 years during sporadic points in time. This broad zone of cultural materials is referred to as a Late Archaic component represented by multiple events.

Four radiocarbon dates on *Rabdotus* shells document a possible stable period in this high terrace towards the lower part of the cultural deposits. The youngest of the four *Rabdotus* dates is 4870 B.P., which came from 30 to 40 cmbs in TU 5 (see Table 10-4). Two other dates came from 60 to 80 cmbs in TU 5, 5220 B.P. and 5790 B.P. These three dates are stratigraphically in order with the earliest dates from the lowest part of the excavation between 70 to 80 cmbs. A fourth date of 5860 B.P. was obtained on *Rabdotus* shells from 50 to 60 cmbs in TU 10. These older snails were apparently displaced from lower context and do not reflect the true age of the cultural materials. None of the identifiable projectile point types recovered from this upper terrace approach these ages obtained on the *Rabdotus* shells. Consequently, the four *Rabdotus* dates appear too old to represent the recovered Late Archaic materials. The shells may reflect the approximate ages of the natural deposits towards the base of the cultural deposits. These shells are small and light weight, and possibly displaced over time. On the basis of cross-dating the recovered point types from this high terrace, the estimated age of the cultural deposits would fall within an estimated time period between ca. 1000 and 3000 B.P.

The multiple Archaic occupations situated beneath the tread of the T<sub>2</sub> surface were initially thought to have been buried by pedoturbation of the sandy Unit 2 deposits. However, closer inspection revealed that this was probably not the case, and that these occupations were most likely buried by Holocene alluvial sedimentation. As was noted earlier, the T<sub>2</sub> surface mostly slopes to the east, or away from the valley axis. The reason for this is that runoff generated by the bedrock surfaces east of 41LM51 has led to the formation of a channel along the interface between Unit 2 and the bedrock at the rear of the valley.



**Figure 10-31.** Photograph facing east from near Lynch Creek Bridge West, at 41LM51. Note the prominent slope in the T<sub>2</sub> surface toward the rear of the terrace. The upland margin is visible in the distance.

This small, locally high gradient stream has cut down along this interface at some point in time since deposition of Unit 2, presumably at the end of the Pleistocene (ca. 14,000 to 10,000 years B.P.) when the nearby Colorado River channel was rejuvenated (cf. Blum and Valastro 1992; Blum et al. 1994). It appears a fair amount of Unit 2 material has been removed by erosion from this setting, as can be seen by the magnitude of the slope concavity at the rear of the T<sub>2</sub> surface where it crosses the highway, (Figure 10-31).

However, excavations along the western slope of this small drainage revealed a thin (<1 m) veneer of loamy alluvial sediment resting unconformably on the truncated top of Unit 2. This sediment is finer textured (loam) than the underlying Unit 2 deposits, which are primarily loamy sand. The mechanism for sedimentation in this location is probably hydraulic damming of runoff during extreme flood events. This small drainage joins Lynch Creek at the foot of a limestone bluff (about 10 to 15 m tall), where the creek channel makes a roughly 110 degrees turn to the southwest (Figure 10-32). Water flowing down Lynch Creek undoubtedly slows somewhat as it runs full force into this bedrock wall, and it is there that the stream draining the T<sub>2</sub> surface and the uplands above where it enters into Lynch Creek. Hydraulic damming at this point would cause ponding of upland-derived floodwater

on the T<sub>2</sub> surface and local deposition of slack water sediments until floodwater receded on the Lynch Creek channel and the runoff was able to drain the T<sub>2</sub> surface (see Figure 10-32). The deposits revealed through the hand-excavations in the T<sub>2</sub> surface are not obviously stratified as slack water sediments often are (cf. Kochel et al. 1982), but this setting is not typical of the tributary mouths favored by those who study slack water sediments for paleoflood reconstruction (cf. Kochel et al. 1982:1170).

The radiocarbon dates obtained from composite *Rabdotus* shells collected within excavation units across the T<sub>2</sub> surface yielded ages between 5600 and 4600 B.P., which corresponds directly with the middle Holocene phase of channel entrenchment on the Colorado River described by Blum and Valastro (1992). It is tempting to link the apparent evidence of large magnitude flooding with the period of channel entrenchment on the Colorado River, as it makes considerable geomorphic sense. Before channel entrenchment, a higher channel bed would have facilitated flooding of the T<sub>2</sub> surface. If this was the case, then we can expect to see further flooding of this surface in the late Holocene just before the channel incised at approximately 1300 B.P. It should be noted that although Blum and Valastro (1992) place this incision event at around 1000 B.P., more recent work in the Colorado basin,

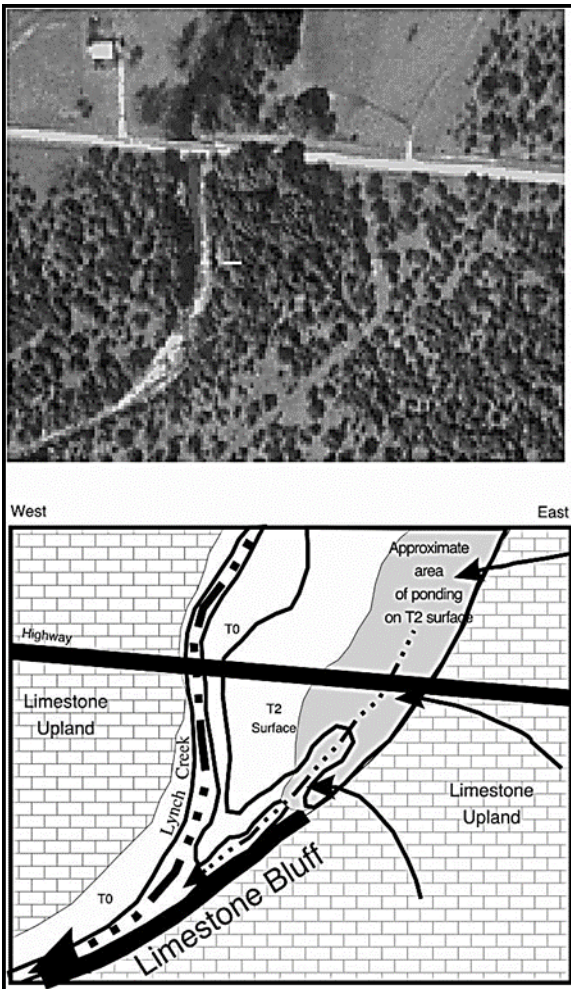


specifically on the North Concho River near San Angelo, found the base of the “modern” alluvium closer to 1300 B.P. (Frederick 1996).

Impressions of the integrity of the occupations on the T<sub>2</sub> surface will logically revolve around the sedimentary history of these deposits. If they were sandy late Pleistocene alluvial deposits with no

evidence of sedimentation, then pedoturbation would be the most likely explanation of their burial and their potential integrity would be low. However, the results of the fieldwork indicate that the sediment surrounding the cultural deposits may be Holocene alluvium, and there is a logical mechanism to explain such sedimentation, namely slack water sedimentation by hydraulically dammed runoff. If these slack water deposits were attributable to slow, episodic sedimentation throughout the long Holocene, then the integrity implications would again be rather poor. But, the results of radiocarbon dating yielded ages in a relatively narrow temporal window, specifically 1,000 years in the middle Holocene when the Colorado River was actively downcutting. Hence, if the radiocarbon dates on the *Rabdotus* shells accurately date the period of occupation and/or sedimentation, then the apparent sedimentation rate is much higher and the potential integrity of these deposits increases.

This optimistic view must be tempered with the reality that the diagnostic artifacts from these deposits are chronologically inconsistent with the radiocarbon dated *Rabdotus* snails, and the shell dates do not accurately reflect the period of occupation or the period of sedimentation. The occupations represent primarily the Late Archaic, roughly expected to date to around 2000 to 2500 B.P, or about 2,000 years younger than the dated snails. This implies one or more of the following: 1) the snails have intruded upwards into the Late Archaic occupations; 2) the Late Archaic materials have intruded downwards into older sediment; 3) older snails were eroded from upland settings and deposited with floodwater on surfaces during the Late Archaic; or 4) the shells have ingested older carbon. The first two scenarios indicate that the integrity of the cultural deposit is somewhat to significantly disturbed. The latter implies that the cultural deposits may retain some stratigraphic integrity, but it would seem logical to see a broader age range of snails in this assemblage if this were



**Figure 10-32. Small section of the Gorman Falls NE DOQQ image of 41LM51 (top panel); line drawing made from aerial illustrating geomorphic relationships (bottom panel).** Note: The site 41LM51 occupies the T<sub>2</sub> surface in the center of the map, between the two drainages. The shaded area depicts roughly the area on the T<sub>2</sub> surface, where ponding of runoff water would occur during extreme flood events.



the case. Unfortunately, the available information fails to favor any of these hypotheses.

At present, it may be best to consider the above explanations as a testable hypothesis. This hypothesis could be tested by comparing three sets of sediment samples collected from; 1) the floodplain of the small stream, 2) column samples in one or more test units, and 3) Unit 2 sediment. Granulometric and mineralogic similarities between the deposit enveloping the cultural deposits and the small stream floodplain, as well as a lithologic break between the deposits surrounding the cultural material and the underlying Unit 2 sands, would support the hypothesis. Granulometric and mineralogical similarities between the site sediment and Unit 2 would favor a pedoturbation burial process.

### 10.5.3 Beveled Edge of Upper Terrace

The third topographic setting was the western beveled edge of the high T<sub>2</sub> terrace with sloping deposits between the high T<sub>2</sub> and low T<sub>0</sub> terraces. A very limited sample of cultural material was recovered from TUs 3 and 7 (0.9 m<sup>3</sup>) that targeted a partial burned rock feature (Feature 1) exposed in the south wall of Trench 1. This feature was buried about 30 to 40 cmbs and represented a part of a cooking apparatus. A limited quantity of lithic debitage and a side scraper (#66-10) were recovered from slightly above and adjacent to Feature 1 rocks (see Table 10-2). It is not clear if the lithic debitage was directly associated with the feature rocks, or if these represent two closely spaced events. Trench 1 revealed no other cultural materials along this sloping deposit. The cultural materials from TUs 3 and 7 were at approximately the same topographic setting as the material eroding from the cow trails further south, where the site was first detected. On the basis of the vertical depth, Feature 1 may represent an extension of the vertical peak in cultural materials detected at slightly higher elevations (ca. 10 to 20 cmbs) in most of the six test units in the high T<sub>2</sub> terrace. However, the lack of

diagnostic projectiles and a date on Feature 1 prevent any assignment of this feature and associated cultural materials to a particular time period.

## 10.6 SUMMARY, CONCLUSIONS, AND DISCUSSION

### 10.6.1 Summary

TxDOT plans to replace the current bridge over Lynch Creek West included a proposed easement south of the existing right-of-way for a temporary low-water crossing during bridge replacement activities.

The original construction of FM 580W, and the bridge development over Lynch Creek, removed an unknown portion of previously unrecorded prehistoric site 41LM51 from within two adjacent Holocene alluvial terraces in the existing right-of-way, on the eastern side of the bridge. Those two alluvial terraces extend southward, and are crossed by the proposed temporary easement.

In 2004 TRC archeologists conducted test excavations to assess the NRHP and SAL eligibility of the remaining portion of prehistoric site 41LM51 within the proposed 10 m wide by 120 m long proposed temporary easement. This long, narrow easement parallels the existing right-of-way east of the creek and crosses three separate and distinct topographic settings, a high T<sub>2</sub> terrace, low T<sub>0</sub> terrace, and the intervening sloping deposits.

TRC archeologists hand-excavated 11 test units, totaling 10.3 m<sup>3</sup>, into these three different settings. A single 16 m long mechanical trench (Trench 1), excavated within the existing right-of-way, provided a window into the deeper deposits, and enabled the geoarcheologist to investigate the sloping deposits. Natural exposures of the low T<sub>0</sub> terrace along the creek side, combined with three test units in the low terrace and six test units in the high T<sub>2</sub> terrace, enabled the geoarcheologist to investigate those distinct settings. The three settings

yielded cultural materials in different contexts, represent different ages of materials. Each setting is addressed separately below.

The low (3 m in height) alluvial T<sub>0</sub> terrace immediately adjacent to Lynch Creek is limited in aerial extent and was investigated through TUs 1, 2, and 4, which totaled 4.6 m<sup>3</sup>. TUs 1 and 2 yielded cultural materials that primarily represent two well-defined components buried in the top 120 cmbs, and stratigraphically separated by some 40 cm.

The T<sub>0</sub> terrace uppermost component (Toyah) was identified between 10 and 40 cmbs, and yielded a complete Perdiz arrow point, limited lithic debitage, and scattered burned rocks. The  $\delta^{13}\text{C}$  corrected date of 1940 B.P. from organic residue from a sandstone burned rock at 20 to 30 cmbs is rejected as too old. Two wood charcoal  $\delta^{13}\text{C}$  corrected dates of 130 B.P. from a depth of 23 cmbs, and a  $\delta^{13}\text{C}$  corrected date of 290 B.P. from 30 to 40 cmbs, likely reflect the age of this Toyah component. The two charcoal dates may be too recent for this component, and potentially intrusive. If not, the dates may indicate this Toyah component potentially represents a rare Protohistoric event. However, no diagnostically Protohistoric artifacts were identified. The relatively low frequency of lithic materials may provide additional indirect support for a Protohistoric period event. The short cell phytolith assemblage from 23 to 25 cmbs that represents the environment at or near the time of the Toyah occupation contains 34.5 percent cool season Pooids, 37.1 percent warm season Panicoids, and 28.4 percent hot dry Chloridoids. These are interpreted to indicate a longer cooler spring and/or fall seasons (C<sub>3</sub> grass intervals) and a warmer summer interval with less moisture than modern day.

Between roughly 80 and 110 cmbs in the T<sub>0</sub> terrace (approximately 40 to 50 cm below the probable Toyah component) lays an Early Archaic component. The 0.5 m<sup>3</sup> testing within TU 1 and TU 2 yielded a fragmented Gower point (#19-10), an

edge-modified flake (#9-11), a burned rock discard pile (Feature 2), moderate frequencies of lithic debitage, scattered burned rocks, and *Rabdotus* shells. Although this component lacked animal bones or charred plant remains, the presence of grass starch on a burned rock indicates grass seeds were potentially a fuel residue or one food resource. Three *Rabdotus* shells from 80 to 90 cmbs yielded a  $\delta^{13}\text{C}$  corrected radiocarbon date of ca. 6750 B.P. provide an approximate age for this component. Slightly below Feature 2, scattered burned rocks and lithic debitage may represent another event or slight vertical displacement of materials from the probable Gower event. Two occupations may be represented in this lower component, and if so, they may be of similar Early Archaic age. The short cell phytolith assemblage from 86 to 88 cmbs that represents the environment at or near the time of the Gower occupation contains 35.5 percent cool season Pooids, 34.6 percent warm moist season Panicoids, and 29.9 percent hot dry Chloridoids and very similar to the Toyah environment. These results again indicate a longer cooler spring and/or fall seasons (C<sub>3</sub> grass intervals) and a warmer summer interval with less moisture compared to the modern environment.

For the low T<sub>0</sub> terrace, the radiocarbon dates and two associated projectile point types (Perdiz and Gower) are correlatively and stratigraphically consistent. The identified point types are generally consistent with the documented absolute ages for the two components (see Table 10-4). No significant mixing with other cultural time periods was detected within these Holocene alluvial deposits. Although some rodent disturbances were noted, and slight dispersal of debitage may be present, these two components are encased in sandy silts with no obvious evidence of significant disturbances.

The second distinct topographic setting is the gradually sloping/beveled deposits between the low T<sub>0</sub> and high T<sub>2</sub> terraces. Trench 1 generally

exhibited a lack of major cultural concentrations in these deposits, excepting one burned rock feature (Feature 1) near the eastern end of Trench 1, near the edge of the high terrace. The western edge of the beveled high T<sub>2</sub> terrace was investigated through 0.9 m<sup>3</sup> that targeted Feature 1 exposed in Trench 1. This shallowly buried, partial burned rock cooking feature was investigated, but limited cultural materials were encountered in direct association. The slightly sloping appearance of burned rocks in Feature 1 below the beveled and currently sloping surface above indicates one cultural occupation from within the high T<sub>2</sub> terrace is eroding out along the western edge. No diagnostic artifacts or charcoal were recovered from the limited area investigated, therefore, no absolute age was determined. The age of Feature 1 is estimated between 1500 and 3000 B.P., based on the recovery of minimally 5 Late Archaic projectile points (1 Frio, 1 Marcos, 1 Lange, and 2 possible Pedernales; Collins 1995, 2004) from the excavations further east across the high T<sub>2</sub> terrace, and four absolute ages on multiple *Rabdotus* shells from those high T<sub>2</sub> terrace deposits.

The third distinct topographic setting, the extensive high T<sub>2</sub> terrace about 6 m above Lynch Creek, was investigated through TUs 5 through 6, and 8 through 11, for a total excavated area of 4.8 m<sup>3</sup>. From the surface to approximately 10 cmbs, recent modern artifacts were present, that included clear glass shards and bottles, tin cans, metal fragments, and whiteware. Prehistoric artifacts generally began to appear at approximately 10 cmbs, and continued to a maximum depth of 90 cmbs. Prehistoric cultural materials from these terrace deposits include: two burned rock features (Features 3 and 4); scattered burned rocks; chipped stone tools (such as 7 dart points, 13 broken bifaces, minimally 62 edge-modified flakes); high quantities of lithic debitage; very sparse bones; a few mussel shell fragments; and sparse charcoal flecks.

The absence of arrow points, the presence of five Late Archaic dart points, and the absence of older dart point types indicate the majority of cultural materials relate to the Late Archaic period. Four radiocarbon dates on *Rabdotus* shells document the possible age of the oldest deposits in this high T<sub>2</sub> terrace. The youngest of the four dates is 4870 B.P., from between 30 and 40 cmbs in TU 5. Two additional shell samples collected from 60 to 80 cmbs in TU 5 returned dates of 5220 and 5790 B.P. These three dates are stratigraphically in order with the oldest dates from the lowest part of the excavation between 70 and 80 cmbs. The oldest date of 5860 B.P. was also obtained from *Rabdotus* shells, but came from a slightly higher context between 50 and 60 cmbs in TU 10. None of the projectile point types recovered and identified corresponds in age to the obtained radiocarbon dates. It is unclear if perhaps these dates on *Rabdotus* shells document cultural events not represented by the diagnostic projectile points recovered. Based on the projectile point types recovered (Frio, Marcos, Lange, and Pedernales), the postulated use period for the majority of the cultural materials recovered from the high T<sub>2</sub> terrace is estimated between 1500 and 3000 B.P.

The absence of vertebrate faunal remains is likely due to poor preservation in this context. However, grass starch on multiple burned rocks, along with maize starch on three biface fragments, provides evidence of multiple plant resource utilization. Even with poor preservation and limited macrobotanical data, microfossil analysis has provided evidence of utilized plant resources. Maize in this context is extremely significant and elevates the importance of this component.

A 38 g sediment sample from outside Features 3 and 4 at 59 to 61 cmbs and thought to represent the natural environment about the time of the Late Archaic period consisted of 37.3 percent cool season Pooids, 34.5 percent warm Panicoids, and 28.2 hot dry Chloridoid short cell phytoliths. These

frequencies are remarkably similar to that of the probable Gower and Toyah environments. The results indicate a longer cooler spring and/or fall seasons ( $C_3$  grass intervals) and a warmer summer interval with less moisture than compared to modern day samples.

In summary, the three different topographic settings crossed by this 120 m long narrow easement contain minimally three separate and vertically distinct cultural components, which represent three general time periods. The low  $T_0$  terrace contains two separate, well-stratified components that do not appear mixed or significantly disturbed. The most recent component is an apparent Late Prehistoric to Protohistoric Toyah component that yielded one Perdiz point. About 40 cm below the Late Prehistoric component, an Early Archaic component is present, as evidenced by a burned rock feature and associated rare Gower point. The  $T_2$  terrace contains a higher density of cultural materials between 10 and 90 cmbs, in a less than ideal context in a sandy partially turbated deposit. This component appears restricted to an estimated 1,500 years during the Late Archaic period, as evidenced through the presence of five Late Archaic projectile points.

### **10.6.2 Conclusions and Discussion**

The deepest component in the low  $T_0$  Holocene alluvial terrace is one of the very few isolated components that have yielded Gower projectile points across central Texas. In his review of the central Texas cultural history, Collins (1995, 2004) lists only five excavated sites that have cultural materials assigned to the 'Early Split Stem' series (which includes the Gower point) with either moderate ( $N = 1$ ) to high ( $N = 4$ ) integrity from a 1,000 year time period between circa 7000 and 8000 B.P. Collins (1995, 2004) indicates the excavated sites with the best context and Gower points are: the Youngsport site (41BL78) (Shafer 1963); Sleeper site (41BC65) (Johnson 1991); Jetta Court site (41TV151) (Wesolowsky et al. 1976);

and Richard Beene site (41BX831) (Thoms and Mandel 2007; Thoms et al. 1996). Collins (1995, 2004) indicates the Landslide (Sorrow et al. 1967) has moderate integrity. Few components with Gower points have been directly radiocarbon dated, fewer still have yielded multiple radiocarbon dates. Consequently, the precise age of the Gower point type is not well-defined. Beyond the identification of the Gower point type at various sites, the general associated assemblages were not documented, nor associated activities discussed. This is partially the result of limited research designs of previously excavated Gower components, often excavated long ago, without the aid of more recent dating and analytical techniques, and targeted general point chronology. A few more intensively investigated sites with Gower components are briefly discussed below to examine the rather limited types of data currently available for this manifestation.

Buried in Holocene alluvial deposits in Bell County, the Youngsport site (41BL78), excavated in 1958, revealed relatively good vertical stratigraphy within eight strata through roughly 260 cm (8.5 ft.) of deposits (Shafer 1963). Testing was quite limited, but yielded 14 newly defined Gower points from a roughly 30 cm thick component (Stratum 8), below a roughly 25 cm thick sterile stratum (Stratum 7). The Gower points were the only point type recovered from Stratum 8. Other stone tools recovered from Stratum 8 included 2 bifaces, 2 scrapers, and 1 Clear Fork Gouge. Additionally, lithic debitage, burned rocks, and snail shells were present. No radiocarbon dates are available for this component or the site.

Although the Sleeper site (41BC65) in Blanco County is listed as having high integrity (Collins 1995, 2004), site excavations and reporting leave many questions concerning context (Johnson 1991). The site was excavated in 1976, but the analyses and report were not published until 15 years later. One major problem is the lack of radiocarbon dates to support the inferred age of the

cultural assemblages. Another is that no significant geoarcheology was conducted. Although the entire cultural deposit was attributed to the Early Archaic period, minimally three different projectile point types are represented in the assemblage and likely represent multiple occupations, and ten identified excavation zones were identified. The Sleeper site yielded 15 points of the Split Stem series, 4 of them Gower points. These 15 points were recovered from six of the ten identified zones, and the Gower points from three different zones. The vertical distribution of the point types within multiple zones leaves considerable uncertainty as to depositional and associative integrity.

In Travis County, Jetta Court (41TV151), tested from December 1968 through January 1969 (32 m<sup>3</sup>), was buried in alluvial deposits 4.5 m deep (Wesolowsky et al. 1976). Five stratigraphic zones were defined based on the sediment color, texture, and cultural material differences. Of interest is the 'Lower Midden' (Zone E) that was about 40 cm thick and yielded 4 Bell, 2 Gower, 3 corner-notched, and 2 triangular point forms. Although Zone E was stratigraphically separated from later events, the occurrence of minimally four temporally separated point types within this single zone indicates probable mixing of events or compression within the zone. Additionally, artifacts were recovered from arbitrary 20 cm thick levels, and mostly screened with 13 mm (1/2 in.) mesh that hindered the recovery of cultural remains within narrow stratigraphic zones. No radiocarbon dates were obtained from this site.

Situated in deep Holocene alluvial deposits along the Medina River in Bexar County, south of the Edwards Plateau, the Richard Beene site (41BX831), excavated in 1991 through 1992, yielded a component from the lower Medina pedocomplex that radiocarbon dates to circa 7000 B.P. This Early Archaic component, investigated through 180 m<sup>2</sup> in a silty clay loam at the base of the Medina Paleosol, contained well-

preserved features, associated stemmed/indented-base points (Uvalde-like), scattered debitage, and burned rocks (Thoms and Mandel 2007; Thoms et al. 1996). Most cultural materials were contained within a narrow 10 cm thick zone, with a few overlapping features, implying multiple occupations on the same surface. Diagnostic projectile points in this zone included stemmed/indented-base types similar to Bandy, Gower, Martindale, and Uvalde points (Thoms 1992; Thoms and Mandel 2007). The presence of multiple point types probably indicate mixing, palimpsests, or a communal event. Faunal remains include deer, pronghorn, canid, rabbit, gopher, squirrel, fish, turtle, and snake (Baker and Steele 2007:230-231).

Excavated in 1960 and 1961 the Landslide site (41BL85), along the Lampasas River in Bell County, revealed culturally stratified material in alluvial deposits (Sorrow et al. 1967). The next to lowest stratum (Stratum V) contained multiple dart point types. The top of Stratum V was nearly 1.5 m (5 ft.) below surface, and roughly 30 to 60 cm (1 to 2 ft.) thick. This thick dark sediment zone yielded minimally three dart point types, which include 8 Gower points, one Bell, and 6 Martindale points, and localized concentrations of fire broken rocks, including Features 3 and 9. Other cultural materials in Stratum V include: 23 burins; 18 scrapers; 19 bifaces; 22 utilized flakes; mussel shells; and snail shells. This zone lacked large processing tools such as choppers, hammerstones, or manos. No radiocarbon dates are available from Stratum V, and only one from this site.

Farther south, towards the southern edge of the Edwards Plateau, extensive data recovery excavations in 2004 at the Gatlin site (41KR621), in Kerr County, yielded a single Gower point from Occupation Zone 1, the lowest identified component (Houk et al. 2008). This zone also yielded 2 Early Barbed, 1 Martindale, and 1 Pandale point. This occupation was in alluvial

deposits that did not reveal discrete events, and occupations were not vertically separated by clear divisions of sterile soil or levels (Frederick 2008). This zone was radiocarbon dated by wood charcoal to between circa 6570 and 6100 B.P. The multiple occupations in this zone represented remnants of repeated short-term duration by small groups (Oksanen et al. 2008). Again, this site contained an occupation zone with Gower points mixed with multiple events over a minimally a 600 year period.

The Ice House site (41HY161), excavated in 2004 along the San Marcos River in Hays County, yielded multiple Gower components (Oksanen 2011). Deep Holocene alluvial deposits yielded a series of three stratified occupation zones that contained Gower points, and yielded multiple radiocarbon dates, from circa 7700 to 6650 B.P. These three occupation zones were contained within some 60+ cm of alluvium that also yielded faunal remains along with extensive chipped stone tool assemblages.

In a synthesis of data from central Texas, Thoms (1992) implies that the Early Archaic period (8000 to 5000 B.P.) had a low population concentrated along the Balcones Escarpment, with a slightly higher site density than the previous period. The unspecialized tools indicate use of a wide range of resources by small, highly mobile bands.

The Gower component in the low T<sub>0</sub> terrace at 41LM51 is quite significant, as it has appears in very good context, has potential for dating, and contains a relatively rare point type about which specific information is limited. It also lies beyond Thoms' (1992) projected concentration corridor for sites along the escarpment. Although charcoal was absent from this 0.5 m<sup>3</sup> excavation, the *Rabdotus* shell date provides a general age for this component. It is possible that a sizable block excavation would yield charcoal, bone, or even burned rocks that might provide multiple additional materials to obtain radiocarbon dates with greater accuracy. A block excavation would also likely

augment the associated artifact assemblage to potentially assess site function, cooking technologies, subsistence activities, and other behavior issues.

The probable Toyah component in the low T<sub>0</sub> terrace at 41LM51 also appears significant. The possibility that this buried Toyah component may represent a Protohistoric event (less than 400 years old) based on the two wood charcoal radiocarbon dates is intriguing and potentially significant. Although two charcoal dates are not conclusive evidence, since they potentially derived from displaced charcoal, the apparently restricted nature of the cultural assemblage, with limited lithic debitage and burned rocks, may indicate a cultural assemblage augmented by metal tools and other European-derived goods. Johnson (1994) places the terminal end of the Toyah culture to around 350 to 300 B.P. (ca. A.D. 1600 to 1650). A few radiocarbon dates derived from Toyah components in central Texas at sites such as Smith Rockshelter (41TV42) (Valastro and Davis 1970:271); Buckhollow (41KM16) (Johnson 1994); 41TG91 (Creel 1990), Mustang Branch (41HY202) and 41HY209, (Collins 1994; Ricklis 1994), Little Paint (41KR226) (Carpenter et al. 2012), and others, fall within the last 300 years, and indicate the possibility some form of the Toyah cultural group continued into the early historic period. Perdiz points recovered from some mission contexts also support the idea that Toyah populations continued into this period. Johnson (1994) goes on to state the ending date for Toyah is not firmly established due to the problems with radiocarbon dating of the most recent part of the time scale. If this component dates to the Protohistoric period, it is quite rare and few native Protohistoric components/sites have been intensively investigated. Native campsites sites of this period are not often recognized or well-documented.

Even if this component does not actually date to the Protohistoric period, the buried nature and overall good context of this Toyah component at 41LM51 adds considerable significance to this location, and greater potential for understanding and interpreting the events present. As argued by Collins (1995), regardless the specific age of this Toyah component, data derived from a well-stratified context, as this component is, provides the greatest opportunity to add valuable information to the Toyah database. Cultural and environmental data from these types of context provides the foundation for comprehensive data recovery and more detailed analyses, and greater contributions. This leads to better data to address most archeological issues.

Once large assemblages are derived from major block excavations, it would be interesting and informative to compare this Toyah assemblage at 41LM51 to the non-Toyah Late Prehistoric assemblage of similar age at 41LM50, which yielded only Bonham and Alba points. Comparing and contrasting these two Late Prehistoric cultural assemblages from sites situated in identical topographic settings and of similar age may provide greater insights into population movements, interactions, resource utilization, site functions, and camp behavioral strategies. This location falls within what Johnson (1994) termed the Classic Toyah homeland. However, with an Alba-Bonham component at 41LM50, within 1.6 km, at the same time period, indicates this area most certainly could fall within Johnson's 'Shared Toyah area'. For an up-to-date review and discussion concerning the Toyah phase/interval, read Arnn (2012a), Kenmotsu and Boyd (2012), and Carpenter et al. (2012). Carpenter et al. (2012) synthesized what is currently known for Toyah, reviewed previous Toyah models, and then revised the Toyah model. Those authors also examined the origins and identity of the Toyah "Folk", placed them in broader context, and discussed macroregional forces that influenced that population.

The high T<sub>2</sub> terrace at 41LM51 contains multiple Late Archaic events that represents an estimated circa 1,500 year period, based on the presence of the five Late Archaic dart points. The two burned rock features did not yield charcoal, which likely could have yielded more accurate dates and documented when the features and associated points were in use. In trying to gain a greater understanding of the maximum time involved for the development of these deposits and the cultural events, *Rabdotus* snail shells from the lower part of the profile were used for radiocarbon dating. The four obtained dates are older than the time periods generally accepted for the recovered projectile point types. Therefore, these four dates probably do not reflect the true age of the cultural strata associated with the Late Archaic projectile points. They likely reflect natural events prior to the cultural activities. These small, light shells are prone to movement within the sediments, which might account for some age discrepancy between the dates and the points. Although the precise ages of the cultural materials within the high T<sub>2</sub> terrace are not clear, it is quite possible that a block excavation targeting a portion of the vertical distribution of materials would yield suitable samples for dating. To minimize potential mixing of differently aged events or internal displacements of small objects like chunks of charcoal or snail shells, burned sandstone might be considered for dating, as it is not as likely to undergo significant displacement within these deposits.

The cultural materials encountered in the high T<sub>2</sub> terrace at 41LM51 do not appear as well-stratified as those in the low T<sub>0</sub> terrace, but do represent a relatively limited time period, estimated at approximately 1,500 years. However, they do not appear mixed with significantly older or younger time periods. The two burned rock features were intact and on the same horizontal plane, which indicate that mixing has not been extensive in the classes of larger materials. Vertical peaks in material density generally occur at the same levels

over multiple, horizontally scattered test units. The horizontal frequencies in classes of material in the test units may indicate variation in human behavior, or it may indicate that specific activity areas are horizontally dispersed across the area. Test Units 5 and 10, towards the middle of the high terrace, yielded higher frequencies of material and more complex vertical distributions of cultural materials than the other four test units in that terrace. These two units may indicate a more intensive use area, but also less well-defined vertical events. Test units in other areas across this terrace exhibit less intensive use that may reflect more isolatable activity areas. These areas might provide useful data concerning both the general Late Archaic period, and the more restricted time of the event within the general period. Although the overall context is not the best in this high T<sub>2</sub> terrace, parts of this terrace indicate there are more restricted activities areas that represent this Late Archaic component, which have the potential to provide baseline data from this county and region for comparison to similar aged sites in other regions. It may also be possible to compare data from 41LM51 and broader generalized Late Archaic assemblages and human behaviors represented, to that of the other two components (Toyah and Gower) to address changes in assemblages, internal camping structure, site functions, lithic resource utilizations, etc. over time from the exact same geographical setting.

Collins (1995, 2004) indicates that the Late Archaic period has had few high integrity sites/components ( $N = 3$ ) or even moderate integrity sites/components ( $N = 2$ ) excavated in central Texas. Much of our current knowledge concerning the Late Archaic centers around data primarily derived from burned rock mounds and middens, which have been occupied/used repeatedly and exhibit complex context and/or mixed assemblages that make it difficult to isolate and unravel specific time or event sensitive assemblages.

Most archeologists generally believe that many different point types were in use during this Late Archaic period, but our understanding the different assemblages and/or groups associated with each of the various points types represented and their interactions is very limited. Many discussions concerning the Late Archaic focus on the broad use of burned rock middens and possible trade connections with groups further east. This reflects a lack of detailed understanding for this general time period across a broad region. No Late Archaic sites have been intensively excavated in Lampasas County, but a few in the surrounding counties have been (e.g., Carpenter and Houk 2012; Carpenter et al. 2010; McNatt et al. 2001; Mehalchick et al. 2004a; Quigg et al. 2011; Simons and Moore 1997). Farther north, at Waco Lake, several Late Archaic components have been excavated and reported (e.g., Mehalchick and Kibler 2008). As in many other locations, the Late Archaic components excavated at Waco Lake were predominately mixed, and generally recognized in thick vertical zones (Mehalchick and Kibler 2008). With its good context, the Siren site (41WM1126) has provided additional radiocarbon dates for refining the Late Archaic chronology, with four of the five identified components that reflect a period from about 2600 to 1600 B.P. (Carpenter and Houk 2012).

Even though this T<sub>2</sub> terrace at 41LM51 does not reflect ideal context with well-defined and separated events, sufficient data appears available to address several research issues and provide, at a minimum, a representative sample of Late Archaic data for this general time period to inform on the local and regional Late Archaic settlement and resource utilization patterns. This would be especially informative with the identification of the grass and maize starch grains on 3 bifaces and 1 burned rock from this component. The presence of maize in this context is much earlier than is currently accepted by regional archeologists and provides an intriguing question as to subsistence patterns.



## 10.7 RECOMMENDATIONS FOR 41LM51

The low T<sub>0</sub> terrace immediately adjacent Lynch Creek yielded two well-defined and stratigraphically separate cultural components, which likely represent the Toyah phase and Gower phase. On the basis of the 1-by-2 m testing results and findings, the lower T<sub>0</sub> terrace of site 41LM51 inside the proposed easement is eligible for inclusion in the NRHP under Criterion D and for designation as an SAL. Avoidance is recommended. If this area cannot be avoided during bridge construction activities, TRC archeologists recommend the two well-defined and separated components in this low T<sub>0</sub> terrace, specifically, the probable Toyah component, between roughly 10 and 40 cmbs, and probable Gower component, between roughly 80 and 110 cmbs, be mitigated prior to any further land disturbance activities.

The upper T<sub>2</sub> terrace yielded cultural materials between roughly 10 and 90 cmbs from 4.8 m<sup>3</sup>, which include large quantities of lithic debitage and scattered burned rocks, two burned rock features, and formal chipped stone tools including five diagnostic projectile points of the Late Archaic period. The deposits lacked macrobotanical and vertebrate faunal remains, therefore no radiocarbon dates were obtained that directly relate to the cultural activities. Four  $\delta^{13}\text{C}$  corrected radiocarbon dates on *Rabdotus* shells from between 30 and 80 cmbs range from 4870 B.P to 5860 B.P. These

four shell dates are older than ages generally accepted for the Late Archaic projectile point types recovered, and do not reflect the true ages of the cultural materials.

The absence of excavated Late Archaic campsites in alluvial context in the local or regional area, combined with the unique presence of maize starch on some chipped stone tools, and the potential to address numerous research questions, such as local and regional Late Archaic settlement and resource utilization patterns, compels TRC archeologists to recommend this Late Archaic component as eligible for inclusion in the NRHP under Criterion D and for designation as an SAL. We also recommend that if this high T<sub>2</sub> terrace within the proposed 10 m wide easement cannot be avoided during bridge construction activities, this apparent Late Archaic component be mitigated prior to any further land development/construction activities.

Following review of the interim report recommendations (Quigg and Frederick 2005), the Brownwood District engineers decided to avoid further impact upon these prehistoric resources within the proposed easement. Instead of using the temporary easement to allow the continued flow of traffic, the roadway was closed to vehicle traffic, and bridge construction activities performed within the existing right-of-way. This avoided additional impact, preserving these valuable cultural resources *in situ*.

## **11.0 PROJECT SUMMARY AND RECOMMENDATIONS**

J. Michael Quigg

### **11.1 INTRODUCTION**

This project initially included the replacement of four existing bridges over small creek crossings along FM 580W (CSJ: #0231-15-032) in Lampasas County, Texas. The Brownwood District of TxDOT planned to acquire temporary easements on private property on the southernmost sides of the bridges for use as low-water crossings during construction periods.

In February 2004, TxDOT Brownwood District archeologist Allen Bettis visited the project area and made initial assessment of the APE at each of these four creek crossings. He observed cultural materials in at least three of the eight quadrants at two of the bridge locations: Lynch Creek Bridge West and Lynch Creek Bridge East. Mr. Bettis determined the remaining two crossings, McAnelly Creek and Browns Creek, had no potential for intact, significant cultural deposits (Bettis personal communication, 2004).

Further inspection of the APEs at the two Lynch Creek crossings by Mr. Bettis, TxDOT archeologist Dr. Mary Jo Galindo, and TRC archeologist Mike Quigg in May 2004 reaffirmed the presence of cultural resource materials in three quadrants within the existing right-of-way and proposed easements at both East and West Lynch Creek Bridge crossings. Mr. Bettis reviewed the Texas Archeological Sites Atlas in June 2004 and found that no previous archeological sites had been recorded within, adjacent, or near the proposed APE. He completed Archeological Impact Evaluation forms for the Lynch Creek East and West structures and recommended that eligibility testing be conducted at these newly discovered archeological sites: 41LM49, 41LM50, and

41LM51. THC subsequently concurred with TxDOT recommendations.

This proposed bridge replacement project necessitated archeological investigation under the requirements of Section 106 of the National Historic Preservation Act, the implementing regulations of 36CRF Part 800, and the Antiquities Code of Texas (Texas Natural Resource Code, Title 9, Chapter 191). This archeological investigation assessed the eligibility of all three cultural resource sites for listing on the NRHP and for designation as a SAL. This document presents the findings and eligibility recommendations following the field investigation. All archeological fieldwork, analysis, reporting, and curation were under TAC Permit No. 3494, issued by the THC to J. Michael Quigg prior to the initiation of the 2004 fieldwork.

### **11.2 PROJECT SUMMARY**

The Lynch Creek Bridge East APE contained prehistoric sites 41LM49 (northeastern and southeastern quadrants) and 41LM50 (southwestern quadrant). Site 41LM51 is in the southeastern quadrant of the Lynch Creek Bridge West APE. The proposed temporary easements slated for the southernmost sides of the current roadway would primarily impact undisturbed areas of sites 41LM50 and 41LM51.

No new impacts were planned for site 41LM49, a burned rock mound site previously impacted by FM 580W roadway construction. Consequently, investigations at 41LM49 were confined to the existing right-of-way and focused on profiling, sampling, and documenting a 17+ m long section of one partially disturbed burned rock mound (BRM 1) under the northern right-of-way fence line at the eastern edge of the APE, and the excavation of two mechanically trenches (12 linear m) plus a single 1-by-1 m test unit in the existing right-of-way on the southern side of the existing road.

At 41LM50, the proposed easement crossed a narrow, single Holocene alluvial terrace that contains buried cultural remains. Two mechanically dug trenches (23 linear m) and nine 1-by-1 m hand-excavated test units (6.5 m<sup>3</sup>) sampled the 109 m long by 10 m wide APE.

At 41LM51, the proposed easement crossed two adjoining Holocene alluvial terraces and the narrow sloping area between the two terraces. One mechanical trench (16 linear m) in the existing right-of-way and eleven 1-by-1 m test units (10.3 m<sup>3</sup>) were excavated across the different landforms in the 10 m wide by approximately 120 m long APE.

In total, the archeological investigations at the three sites (41LM49, 41LM50, and 41LM51) included the excavation of five mechanical trenches that totaled 51 linear meters in length, hand-excavation of 21 1-by-1 m test units that encompassed 17.2 m<sup>3</sup>, plus profiling of a nearly 18 m long section of BRM 1 at 41LM49.

These investigations included detailed geoarcheological investigations that documented the late Quaternary alluvial deposits at the site locations. Five depositional units (Units 1 through 5), which included three distinct Holocene terraces were identified and described. These include a low T<sub>0</sub> surface along the margins of Lynch Creek, a slightly higher T<sub>1</sub> surface, and a much higher T<sub>2</sub> surface. A late Quaternary lag gravel deposit (Unit 1) is in the vicinity, and was probably a lithic procurement source used by occupants at these sites.

This technical report describes the archeological eligibility testing program implemented at these three previously unrecorded prehistoric sites (41LM49, 41LM50, and 41LM51), and documents the findings, results, interpretations, and eligibility recommendations.

### 11.2.1 Site 41LM49 Summary

This is a partial burned rock mound/midden east of Lynch Creek Bridge East, within the existing FM 580W right-of-way, at the eastern edge of the project area. The newly created profile of BRM 1 along the eroding edge of the existing right-of-way documented a nearly 18 m long subsurface burned rock lens that varied from 10 to 180 cm thick. The majority of the buried burned rock lens varied between 30 and 60 cm thick. A deep, roughly 1.5 m wide rock filled pit(s) reached roughly 180 cmbs near the southern end of the lens. Other than the deep, rock filled pit(s) that extended below the broader lens of burned rocks, little else was unusual about the subsurface contents of BRM 1.

Very tiny charcoal flecks, only a few pieces of lithic debitage, and sparse snail shells were observed in the newly created profile. Three individual *Rabdotus* snail shells extracted from the deep burned rock filled pit were radiocarbon dated and yielded  $\delta^{13}\text{C}$  corrected dates of 6660 B.P., 4640 B.P., and 4460 B.P. Two radiocarbon dates derived from residues in the burned rocks yielded  $\delta^{13}\text{C}$  corrected dates of 1570 B.P. and 2660 B.P., considerably younger than the *Rabdotus* dates. These two rock residue dates are considered a higher probability for reflecting the true age of the bulk of the BRM deposits.

The presence of the deep rock filled pit(s) below the mounded mass of burned rocks may support the interpretation that BRM 1 represents a massive discard of used rocks employed in a central *in situ* cooking feature(s). This deep pit(s) potentially represents the primary or central cooking facility surrounded by quantities of broken and discarded burned rocks from the cooking processes. Starch grain analysis on five burned rocks attempted to identify foods cooked with the rocks. The rocks yielded only three starch grains: two lenticular grass grains likely to represent little barley (*Hordeum pusillum*) or Canada Wildrye (*Elymus* sp.), and one unidentified grain. The apparent mano

from the midden context failed to yield any starch grains. The few grains present combined with the possibility that these may not be food residues, leaves open the question of what was cooked in this BRM (see Black et al. 1997 and Mauldin et al. 2003 for discussions of the age and functions of similar burned rock features). Unfortunately, the lack of preserved organic remains within the midden precludes identification of the types of foods cooked within this feature.

Investigations south of the existing roadway at 41LM49 yielded limited archeological data, only a small isolated burned rock feature (Feature 2) in the Holocene alluvial deposits. Geoarcheological interpretations of the deposits that contained Feature 2 indicate the deposits are of Late Prehistoric age, probably less than 1,300 years old. If so, Feature 2 and other sparse materials south of the road are not associated with the BRMs north of the road.

### **11.2.2 Site 41LM50 Summary**

This is a buried terrace campsite on the southwestern quadrant of Lynch Creek Bridge East. The eligibility assessment of the proposed 10 m wide by 109 m long proposed easement for a low-water crossing was accomplished through mapping the proposed easement, hand-excavating 6.5 m<sup>3</sup> in nine test units and documenting their contents, plus mechanically excavating two trenches and documenting exposed deposits.

Minimally one shallowly buried, well-defined Late Prehistoric component, and possibly a second deeper but dispersed component, was detected in the top 80 cmbs of late Holocene alluvial deposits sampled. The upper component lies roughly between 5 and 30 cmbs, and appeared concentrated within the 30 m closest to Lynch Creek. This upper component is characterized by 1 Bonham and 1 Alba arrow point, 31 formal and informal stone tools, 584 scattered lithic debitage, scattered and clustered burned rocks, and at least 2 identified

burned rock features. This component was radiocarbon dated to within the last 550 years by two wood charcoal samples from Feature 2, and two dates of 330 B.P. and 430 B.P. from organic residues in sandstone burned rocks from Feature 1. Three of the four dates support the Late Prehistoric assignment, and restricted timing of the event.

The paucity of both macrobotanical and vertebrate remains leaves questions concerning subsistence unclear. Starch grain analysis on 7 lithic tools and 16 burned rocks from Features 1 and 2 provides an evidentiary glimpse. A total of 9 starch grains were recovered: 2 lenticular grasses, 2 unidentified grass grains, 2 unknown grains, 3 maize grains, and 1 possible maize grain. Minimally four unidentified grains were gelatinized and one was heated. The maize grains indicate at least one plant food resource culturally processed at this campsite, whereas the grass starch may represent a fuel or a food resource.

Lower in the alluvial deposits, and within the same thick cumelic soil, sparse lithic debitage, scattered charcoal, and the occasional burned rock and lithic tool (7 edge-modified flakes, 1 biface, and 1 scraper) were present between 50 and 80 cmbs. No diagnostic artifacts or features were encountered within this deeper 30 cm thick zone. Vertebrate faunal remains and macrobotanical remains were scarce. Two wood charcoal chunks from 70 to 80 cmbs yielded  $\delta^{13}\text{C}$  corrected dates of 930 B.P. and 950 B.P., which potentially indicate an earlier event(s). These scattered artifacts may represent at least one dispersed lower component. The absence of recognizable cultural features and the dispersed nature of the debitage and burned rocks hinder our understanding of this deeper material.

### **11.2.3 Site 41LM51 Summary**

This is a multiple component prehistoric campsite buried within two adjoining Holocene alluvial terraces (T<sub>0</sub> and T<sub>2</sub>) on the southeastern side of Lynch Creek Bridge West. The assessment of the

proposed 10 m wide by 120 m long easement for a low-water crossing was accomplished through mapping the proposed easement, hand-excavation of 10.3 m<sup>3</sup> in 11 test units within the easement, and mechanical excavation of one 16 m long trench in the existing right-of-way. Minimally three buried components were identified. Two well-defined, well-stratified, and vertically separated components are in the low T<sub>0</sub> terrace: a probable Late Prehistoric/Protohistoric Toyah component above an Early Archaic probable Gower component. A third vertically and horizontally dispersed Late Archaic component was detected between 10 and 90 cmbs in the higher T<sub>2</sub> alluvial terrace.

In the T<sub>0</sub> terrace, the upper probable Toyah component lies between approximately 10 and 40 cmbs. This yielded 1 complete Perdiz point, 13 pieces of lithic debitage, scattered burned rocks, and 1 edge-modified flake from 0.6 m<sup>3</sup>. No faunal remains were present, and charcoal was scattered and sparse. Starch grains from one limestone burned rock indicate grass seeds were processed. Two wood charcoal chunks yielded  $\delta^{13}\text{C}$  corrected dates of 130 B.P. from 23 cmbs, and 290 B.P. from between 30 and 40 cmbs. If directly associated with the Perdiz point, the charcoal dates refine the approximate age of the Toyah component.

The lower probable Gower component in the T<sub>0</sub> terrace lies between 80 and 110 cmbs. This component yielded one broken Gower point, an edge-modified flake, moderate frequencies of lithic debitage, a small burned rock discard pile (Feature 2), and scattered burned rocks from 0.5 m<sup>3</sup>. No faunal bones, mussel shells, or charcoal were present. Three *Rabdotus* shells from 80 to 90 cmbs yielded a  $\delta^{13}\text{C}$  corrected radiocarbon date of 6750 B.P., which provides an approximate age for this likely Gower component. Four burned rocks submitted for starch grain analysis yielded only one gelatinized unidentifiable starch grain. This processed starch grain supports the interpretation of burned rock utilization for cooking plant resources.

The high T<sub>2</sub> terrace contains a higher density of cultural materials in a less than ideal context with artifacts vertically dispersed between 10 and 90 cmbs. The cultural assemblage from 4.8 m<sup>3</sup> includes formal and informal lithic tools, quantities of lithic debitage, scattered burned rocks, and two burned rock features (Features 3 and 4), but no organics such as faunal bones, mussel shells, or charcoal.

Selected artifacts were submitted for starch grain analysis. Three starch grains were identified from the submission of 9 burned rocks (5 from Feature 3 and 4 from Feature 4). All three grains represent unidentifiable grasses. Two grains were gelatinized, which indicate the burned rocks were likely used to cook grasses. Unexpectedly, analysis on three unwashed biface fragments yielded three maize starch grains, two grass grains, and one unknown grain, which indicates these bifacial tools were used for processing maize and other grasses. Unfortunately, the specific timing of the event(s) associated with these three bifaces is unclear. However, this estimated Late Archaic period is not currently an accepted time period for the presence of maize.

The vertically dispersed artifacts within this zone are probably restricted to an estimated 1,500 years within the Late Archaic period, as indicated by the presence of 5 Late Archaic dart points of four different types (1 each of Frio, Marcos, Lange, and 2 possible Pedernales). Lack of charcoal or other carbonized macrobotanical remains did not permit direct radiocarbon dating of these deposits. Four radiocarbon dates on scattered *Rabdotus* shells document a possibly stable period in the high T<sub>2</sub> terrace, towards the lower part of the cultural deposits. The youngest of the four dates is 4870 B.P., from 30 to 40 cmbs in TU 5. Two older dates of 5220 and 5790 B.P. came from between 60 and 80 cmbs in TU 5. The best projected age for this component falls within the Late Archaic period (ca. 1500 to 3000 B.P.; Collins 1995, 2004), based on

the presence of five diagnostic Late Archaic dart points, and the absence of arrow points.

### **11.3 PROJECT RECOMMENDATIONS**

#### **11.3.1 Site 41LM49 Recommendations**

Previous construction of FM 580W heavily impacted previously unrecorded site 41LM49 and removed an unknown portion of the site from within the existing right-of-way. No new right-of-way was proposed for the immediate site area, which contained only a linear truncated and eroding edge of Burned Rock Mound 1 (BRM 1) underlying the existing northern right-of-way fence. TRC archeologists documented that portion of BRM 1 that remained within the existing disturbed right-of-way. Very limited cultural deposits remain within the existing right-of-way, and those that are present have sustained significant impact and are heavily disturbed and are not eligible for listing on the NRHP under Criterion D, or significant enough to designate as an SAL. On the basis that no new right-of-way is proposed, and the cultural resources within the existing right-of-way have been documented, we recommend no further archeological work within the existing right-of-way at site 41LM49.

#### **11.3.2 Site 41LM50 Recommendations**

The investigated part of site 41LM50 of the proposed temporary easement contains one well-defined Late Prehistoric age component within the top 30 cmbs. This upper component has the potential to yield further information pertinent to answering research questions about local or regional prehistory under NRHP Criterion D, specifically, questions concerning the age and settlement patterns associated with Alba/Bonham arrow points. Therefore, the investigated area of buried site 41LM50 within the top 30 cmbs of the proposed highway easement is recommended as eligible for listing in the NRHP under Criterion D

and for designation as an SAL. Avoidance is recommended. If this area of the easement cannot be avoided, then it is recommended that the portion of site 41LM50 within the proposed easement for the low-water crossing of Lynch Creek, specifically the Late Prehistoric component in the top 30 cmbs, be targeted for a mitigation excavation program prior to any earth-disturbing activities.

#### **11.3.3 Site 41LM51 Recommendations**

The three identified components at site 41LM51 have the potential to yield further information pertinent to answering diverse research questions about local and regional prehistory under NRHP Criterion D. Therefore, the investigated area of site 41LM51, which lies within the proposed temporary easement, is recommended as eligible for listing in the NRHP under Criterion D and for designation as an SAL. Avoidance is recommended. If this easement area cannot be avoided, then it is recommended the component portions of site 41LM51 (specifically the Late Prehistoric Toyah and Early Archaic Gower components in the low T<sub>0</sub> terrace, and the Late Archaic component in the high T<sub>2</sub> terrace) be targeted for a mitigation excavation program prior to any earth-disturbing activities.

The THC concurred with the above recommendations for sites 41LM50 and 41LM51, which they determined are eligible for listing on the NRHP under Criterion D and for designation as SALs. Subsequently, the Brownwood District office determined that these cultural resource sites within the proposed easement could be avoided by closing the roadway and restricting the construction activities to the current right-of-way. The construction project was begun in July 2005, and completed in February 2006. Prehistoric sites 41LM50 and 41LM51 within proposed easements were avoided, and sustained no additional impact during bridge replacement activities.

*This page intentionally left blank.*

## 12.0 REFERENCES CITED

- Allison, J. E.  
2001 *Soil Survey of Lampasas County, Texas*. Natural Resources Conservation Service. United States Department of Agriculture, Soil Conservation Service, in cooperation with the Texas Agricultural Experiment Station.
- Alvarez, C.  
2005 Stable Carbon Isotopes from the Stiver Ranch Burial Sinkhole (41KM140). *Bulletin of the Texas Archeological Society* 76:165-182.
- Andrefsky, W. Jr.  
1998 *Lithics: Macroscopic Approaches to Analysis*. Cambridge University Press, Cambridge.
- Arnn III, J. W.  
2012a *Land of the Tejas: Native American Identity and Interaction in Texas, A.D. 1300-1700*. University of Texas Press, Austin.
- 2012b Defining Hunter-Gather Social Identity and Interaction at the Regional Scale. In *Toyah Phase of Central Texas, Late Prehistoric Economic and Social Processes*, edited by N. A. Kenmotsu and D. K. Boyd, pp. 90-110. Texas A&M University Press, College Station.
- Babot, M. del Pilar  
2003 Starch Grain Damage as an Indicator of Rood Processing. In *Phytolith and Starch Research in the Australian-Pacific-Asian Regions: The State of the Art*, edited by D. M. Hart and L. A. Wallis, pp. 69-81. Papers from a conference held at the ANU, August 2001, Canberra, Australia. Pandanus Books.
- Baker, B. W.  
1998 Vertebrate Faunal Remains from the 1/4–inch and 1/8-inch Screens. In *Wilson-Leonard An 11,000-year Archeological Record of Hunter-Gatherers in Central Texas*, Volume V, assembled and edited by M. B. Collins, pp. 1463-1509. Studies in Archeology 31, Texas Archeological Research Laboratory, The University of Texas at Austin, and Archeology Studies Program, Report 10, Texas Department of Transportation, Environmental Affairs Division, Austin.
- Baker, B. W. and D. Gentry Steele  
2007 Late Pleistocene Through Late Holocene Faunal Assemblage. In *Archaeological and Paleocological Investigations at the Richard Beene Site 41BX831: South-Central Texas*, edited by A. V. Thoms and R. D. Mandel, pp. 229-239. Reports of Investigations No. 8. Center for Ecological Archaeology, Texas A&M University, College Station.
- Barnes, V. E.  
1976 *Geological Atlas of Texas, Brownwood Sheet*, Monroe George Cheney Memorial Edition, Bureau of Economic Geology, The University of Texas at Austin.
- Bement, L. C.  
1991 The Thunder Valley Burial Cache: Group Investment in a Central Texas Sinkhole Cemetery. *Plains Anthropologist* 36(135):97-109.
- 1993 A flexed Burial from Llano County, Texas. *Bulletin of the Texas Archeological Society* 61:281-287.



- 1994 *Hunter-Gather Mortuary Practices During the Central Texas Archaic*. The University of Texas Press, Austin.
- Bender, M. M.  
1971 Variations in the  $^{13}\text{C}/^{12}\text{C}$  ratios of plants in relation to the pathway of photosynthetic carbon dioxide fixation. *Phytochemistry* 10:1239-1244.
- Bender, A. and B. Bender  
1962 A Vertical Shaft Burial in Uvalde County, Texas. *The Texas Caver* 7(4):41-42.
- Black, S. L.  
1986 *The Clemente and Herminia Hinojosa Site, 41JW8: A Toyah Horizon Campsite in Southern Texas*. Special Report 18. Center for Archaeological Research, The University of Texas at San Antonio.  
1989 Central Texas Plateau and Prairie. In *From the Gulf to the Rio Grande: Human Adaptation in Central, South, and Lower Pecos Texas*, edited by T. R. Hester, S. L. Black, D. G. Steels, B. W. Olive, A. A. Fox, K. Reinhard, and L. C. Bement, pp. 17-38. Arkansas Archeological Survey Research Series No. 33.  
2003 Archaic Pavo Real. In *Pavo Real (41BX52): A Paleoindian and Archaic Camp and Workshop on the Balcones Escarpment, South-Central Texas*, by M. B. Collins, D. B. Hudler, and S. L. Black, pp. 191-232. Studies in Archeology 41, Texas Archeological Research Laboratory, The University of Texas At Austin, and Archeological Studies Program, Report 50, Environmental Affairs Division, Texas Department of Transportation.
- Black, S. L. and A. J. McGraw  
1985 *The Panther Springs Creek Site: Cultural Change and Continuity within the Upper Salado Creek Watershed, South-Central, Texas*. Archaeological Survey Report, No. 100, Center for Archaeological Research, The University of Texas at San Antonio.
- Black, S. L. and D. G. Creel  
1997 The Central Texas Burned Rock Midden Reconstructed. In *Hot Rock Cooking on the Greater Edwards Plateau: Four Burned Rock Midden Sites in West Central Texas*. Volumes I and II, by S. L. Black, L. W. Ellis, D. G. Creel, and G. T. Goode, pp. 269-305. Texas Archeological Research Laboratory, The University of Texas at Austin, Studies in Archeology 22, and Texas Department of Transportation, Environmental Affairs Department, Archeology Studies Program, Report 2.
- Black, S. L., L. W. Ellis, D. G. Creel, and G. L. Goode  
1997 *Hot Rock Cooking on the Greater Edwards Plateau: Four Burned Rock Midden Sites in West Central Texas*. Volumes I and II, Texas Archeological Research Laboratory, The University of Texas at Austin, Studies in Archeology 22, and Texas Department of Transportation, Environmental Affairs Department, Archeology Studies Program, Report 2.
- Blair, W. F.  
1950 The Biotic Provinces of Texas. *The Texas Journal of Science* 2(1):93-117.
- Blum, M. D. and S. Valastro Jr.  
1992 Quaternary Stratigraphy and Geoarchaeology of the Colorado and Concho Rivers, West Texas. *Geoarchaeology* 7:419-448.

- Blum, M. D., R. S. Toomey III, and S. Valastro Jr.  
1994 Fluvial Response to Late Quaternary Climatic and Environmental Change, Edwards Plateau, Texas. *Palaeogeography, Palaeoclimatology, Palaeoecology* 108:1-21.
- Bohrer, V.  
1987 The Plant Remains from La Ciudad, A Hohokam Site in Phoenix. In *Specialized Studies in the Economy, Environment and Culture of La Ciudad*, edited by J. A. E. Kisselburg, G. E. Rice, and B. Spears, pp. 67-202. Office of Cultural Resource Management, Department of Anthropology, Arizona State University, Tempe.
- Bond, C. L.  
1978 *Three Archeological Sites at Hoxie Bridge, Williamson County, Texas*. Texas A&M Research Foundation, Report No. 43, College Station.
- Bousman, C. B.  
1998 Paleoenvironmental Change in Central Texas: The Palynological Evidence. *Plains Anthropologist* 43(164):201-219
- Boyd, D. K.  
2012 What is the Northern Toyah Phase? In *The Toyah Phase of Central Texas: Late Prehistoric Economic and Social Process*, edited by N. A. Kenmotsu and D. K. Boyd, pp. 128-151. Texas A&M Press, College Station.
- Bozarth S. and T. Woodburn  
2010 Paleoenvironmental Reconstruction at West Amarillo Creek, Potter County, Texas, Based on Biosilicate Analysis and Palynology. In *Landis Property: Data Recovery at Three Prehistoric Sites (41PT185, 41PT186, and 41PT245) in Potter County, Texas*, by J. M. Quigg, C. D. Frederick, P. M. Matchen, and K. G. DuBois, pp. 697-733. TRC Environmental Corporation, TRC Technical Report 150832. Manuscript on file with TRC in Austin and Bureau of Land Management, Santa Fe.
- Brown, K. M.  
1985 Three Caches of Guadalupe Tools from South Texas. *Bulletin of the Texas Archeological Society* 56:75-126.
- Brown, D. O., R. P. Watson, and J. M. Jackson  
1987a *Archeology at Aquilla Lake: 1978 – 1982 Investigations, Volume II*. Texas Archeological Survey, Research Report 81, The University of Texas at Austin.
- Brown, D. O., R. P. Watson, D. Peter, and V. Rawn-Schatzinger  
1987b The McDonald Site – 41HI105. In *Archeology at Aquilla Lake: 1978 – 1982 Investigations, Volume II*, by D. O. Brown, R. P. Watson, J. M. Jackson, pp. 38-1 through 38-145. Texas Archeological Survey, Research Report 81, The University of Texas at Austin.
- Brownlow, R. K.  
2003 *Archeological Investigations at 41WM815, A Backland Prairie Site, Williamson County, Texas*. Studies in Archeology 36, Texas Archeological Research Laboratory, The University of Texas at Austin and Archeological Studies Program, Report 23, Environmental Affairs Division, Texas Department of Transportation, Austin.
- Brownlow, R. K., C. D. Frederick, and J. Wiersema  
2004 *National Register of Historic Places Eligibility Testing of 2 sites (41WM650 and 41WM651) Located within the Cedar Park Town Center Development, Cedar Park,*

- Williamson County, Texas. Horizon Environmental Services, Report Number HJN 040024 AR.
- Callahan, E.  
1979 The Basics of Biface Knapping in the Eastern Fluted Point Tradition: A Manual for Flintknappers and Lithic Analysts. *Archeology of Eastern North America* 7:1-180.
- Carpenter, S.  
2012 Chapter 13, Synthesis and a Revised Model of Toyah. In *The Little Paint Site: A Classic Toyah Camp on the South Llano River, Kimble County, Texas*, by S. M. Carpenter, K. A. Miller, C. D. Frederick, L. G. Cecil, M. C. Cody, and A. Peyton, pp. 233-262. SWCA Environmental Consultants, SWCA Cultural Resources Report No. 12-429 and Texas Department of Transportation, Archeological Studies Program, Report No. 148.
- Carpenter, S. and B. A. Houk  
2012 Siren Site Chronology: A Reconstruction of the Late Archaic to Late Prehistoric Temporal Sequence of Eastern Central Texas. *Bulletin of the Texas Archeological Society* 83:99-128.
- Carpenter, S., M. Chavez, K. Miller, and K. Lawrence  
2006 *The McKinney Roughs Site (41BP627): A Stratified Late Archaic II Site on the Colorado River Terraces, Bastrop County, Texas*. SWCA Cultural Resources Report No. 02-313, Austin.
- Carpenter, S., C. T. Hartnett, J. D. Lowe and K. Miller  
2010 *Data Recovery Investigations on the Cowdog Crossing Site: A Study of the End of the Archaic, Fort Hood, Coryell County, Texas*. United States Army Fort Hood, Archeological Resource Management Series, Research Report No. 56.
- Carpenter, S. M., K. A. Miller, C. D. Frederick, L. G. Cecil, M. C. Cody, and A. Peyton  
2012 *The Little Paint Site: A Classic Toyah Camp on the South Llano River, Kimble County, Texas*. SWCA Environmental Consultants, SWCA Cultural Resources Report No. 12-429 and Texas Department of Transportation, Archeological Studies Program, Report No. 148.
- Church, F.  
2000 A Summary of the Results of a High Power Use-Wear Analysis of a Sample of Chipped Stone Artifacts from Site 41ZP364, Zapata County, Texas. In *Data Recovery at 41ZP364: An Upland Campsite at Falcon Reservoir, Zapata County, Texas*, by J. M. Quigg and C. Cordova, pp. 247-268. Technical Report No. 22317, TRC Mariah Associates Inc., Austin.
- Collins, M. B.  
1970 On the Peopling of Hitzfelder Cave. *Bulletin of the Texas Archeological Society* 41:301-304.
- 1994 The Late Archaic in the Project Area. In *Archaic and Late Prehistoric Human Ecology in the Middle Onion Creek Valley, Hays County, Texas*, by R. A. Ricklis and M. B. Collins, pp. 101-188. Studies in Archeology 19, Texas Archeological Research Laboratory, The University of Texas at Austin.
- 1995 Forty Years of Archeology in Central Texas. *Bulletin of the Texas Archeological Society* 66:361-400.

- 2004 Archeology in Central Texas. In *The Prehistory of Texas*, edited by T. K. Perttula, pp. 101-126. Texas A&M University Press, College Station.
- Collins, M. B. (assembler and editor)
- 1998 *Wilson-Leonard An 11,000-year Archeological Record of Hunter-Gatherers in Central Texas*. Five Volumes. Studies in Archeology 31, Texas Archeological Research Laboratory, The University of Texas at Austin, and Archeology Studies Program, Report 10, Texas Department of Transportation, Environmental Affairs Division, Austin.
- Collins, M. B. and P. Headrick
- 1990 Fluorescent Properties of "Edwards" and Related Cherts of Central Texas. Manuscript in possession of the authors.
- Collins M. B., B. Ellis, and C. Dodt-Ellis
- 1990 *Excavations at the Camp Pearl Wheat Site (41KR243): An Early Archaic Campsite on Town Creek, Kerr County, Texas*. Studies in Archeology 6, Texas Archeological Research Laboratory, The University of Texas at Austin.
- Crawford, D. D.
- 1965 The Granite Beach Site, Llano County, Texas. *Bulletin of the Texas Archeological Society* 36:71-97.
- Creel, D. G.
- 1986 A Study of Prehistoric Burned Rock Middens in West Central Texas. Unpublished Ph.D. dissertation. Department of Anthropology, The University of Arizona, Tucson.
- 1990 *Excavations at 41TG91, Tom Green County, Texas, 1978*. Publications in Archeology, Report No. 38, Texas Department of Transportation, Austin.
- 1991 Assessing the Relationship Between Burned Rock Midden Distribution and Archaic Subsistence in West Central Texas. In *Burned Rock Middens of Texas: An Archeological Symposium*, edited by T. R. Hester, pp. 33-43. Studies in Archeology 13, Texas Archeological Research Laboratory, The University of Texas at Austin.
- Creel, D. and A. Johnson
- 2002 *The Central Texas Ceramics Project*. Paper Presented at the 73<sup>rd</sup> Annual Meeting of the Texas Archeological Society, Laredo, Texas.
- Cummings, L. S. and R. A. Varney
- 2010 Pollen and Starch Analysis of Samples from 41CV389, Fort Hood, Texas. In *Data Recovery Investigations on the Cowdog Crossing Site: A Study of the End of the Archaic, Fort Hood, Coryell County, Texas*, by S. Carpenter, C. R. Hartnett, J. D. Lowe, and K. A. Miller, pp. 123-130. United States Army Fort Hood, Archeological Resource Management Series, Research Report No. 56.
- Decker, S., S. L. Black, and T. Gustavson
- 2000 *The Woodrow Heard Site, 41UV188—A Holocene Terrace Site in the Western Balcones Canyonlands of Southwestern Texas*. Texas Archeological Research Laboratory, The University of Texas at Austin, Studies in Archeology, No. 33, and Environmental Affairs Division, Texas Department of Transportation, Archeology Studies Program, Report 14. Austin.

- Denniston, R. H.  
1904 The Growth and Organization of the Starch Grain. Unpublished Ph.D. dissertation. University of Wisconsin, Madison.
- Dering, P.  
1997 Appendix D: Macrobotanical Remains. In *Hot Rock Cooking on the Greater Edwards Plateau: Four Burned Rock Midden Sites in West Central Texas*. Volume II, by S. L. Black, L. W. Ellis, D. G. Creel, and G. T. Goode, pp. 571-600. Texas Archeological Research Laboratory, The University of Texas at Austin, Studies in Archeology 22, and Texas Department of Transportation, Environmental Affairs Department, Archeology Studies Program, Report 2.
- 1998 Chapter 40: Carbonized Plant Remains. In *Wilson-Leonard An 11,000-year Archeological Record of Hunter-Gatherers in Central Texas*, assembled by M. B. Collins, pp. 1609-1636, Volume V. Studies in Archeology 31, Texas Archeological Research Laboratory, The University of Texas at Austin, and Archeology Studies Program, Report 10, Texas Department of Transportation, Environmental Affairs Division, Austin.
- 2003 Appendix C: Botanical Perspective on Land use in the Cross Timbers and Prairies: Plant Remains from Burned Rock Middens in Bowie County, Texas. In *Archaeological Testing to Determine the National Register Eligibility Status of Eighteen Prehistoric Sites on Camp Bowie, Brown County, Texas*, Volumes 1 and 2, by R. P. Mauldin, D. L. Nickels, and C. J. Broehm, pp. 61-91. Center for Archaeological Research, The University of Texas at San Antonio, Archaeological Survey Report, No. 334.
- 2007 Assessment of Botanical and Faunal Assemblages from Paleoindian and Early Archaic Components on the Periphery of the Southern Plains. *Bulletin of the Texas Archeological Society* 78:177-195.
- 2008 Late Prehistoric Subsistence Economy on the Edwards Plateau. *Plains Anthropologist* 53(205):59-77.
- Dial, S. W., A. C. Kerr, and M. B. Collins  
1998 Chapter 13: Projectile Points. In *Wilson-Leonard An 11,000-year Archeological Record of Hunter-Gatherers in Central Texas*. Volume II assembled and edited by M. B. Collins, pp. 313-445. Studies in Archeology 31, Texas Archeological Research Laboratory, The University of Texas at Austin, and Archeology Studies Program, Report 10, Texas Department of Transportation, Environmental Affairs Division, Austin.
- Dillehay, T. D.  
1974 Late Quaternary Bison Population Changes on the Southern Plains. *Plains Anthropologist* 19(65):180-196.
- Dickens, W. A.  
1993 *Lithic Analysis. In Archaeological Investigations in Bull Branch: Results of the 1990 Summer Archaeological Field School*, edited by D. L. Carlson, pp. 75-111. United States Army Fort Hood, Archeological Resource Management Series, Research Report Number 19.
- Eickmeier, W. G. and M. M. Bender  
1976 Carbon Isotope Ratios of Crassulacean Acid Metabolism Species in Relation to Climate and Phytosociology. *Ecologia* 25:341-347.

- Field, A.  
1956 Archeological Investigations in Lampasas, Burnet, Llano, and San Saba Counties, Texas. *Bulletin of the Texas Archeological Society* 27:161-184
- Frederick, C. D.  
1996 Geomorphic Investigations. In *Early Archaic Use of the Concho River Terraces: Archaeological Investigations at 4ITG307 and 4ITG309, Tom Green County, Texas*, by J. M. Quigg, J. Peck, C. Lintz, A. C. Treece, C. D. Frederick, R. Clem, G. L. Ellis, P. Schuchert, and J. T. Abbott, pp. 85-108. Technical Report Number 11058, TRC Mariah Associates, Inc., Austin.
- 2008 Paleoenvironmental and Site Formation Processes. In *The Gatlin Site (41KR621): Investigating Archaic Lifeways on the Southern Edwards Plateau of Central Texas*, by B. A. Houk, K. A. Miller, and E. R. Oksanen, pp. 6-1 through 6-20. SWCA Environmental Consultants, SWCA Cultural Resources Report No. 149 and Texas Department of Transportation, Archeological Studies Program, Report No. 108.
- Frederick, C. D. and C. Ringstaff  
1994 Lithic Resources at Fort Hood: Further Investigations. In *Archaeological Investigations on 571 Prehistoric Sites at Fort Hood, Bell, and Coryell Counties, Texas*, edited by W. N. Trierweiler, pp. 125-181. United States Army Fort Hood, Archeological Resource Management Series, Research Report No. 31.
- Gadus, E. F., R. C. Fields and K. W. Kibler  
2006 *Data Recovery Excavations at the J. B. White Site (41MM341), Milam County, Texas*. Texas Department of Transportation, Environmental Affairs Division, Archeological Studies Program, Report No. 87, and Prewitt and Associates, Inc., Reports of Investigations No. 145, Austin.
- Hardy, B. L.  
2002 Results of Microscopic Use-wear and Residue Analyses from Site 41WB557, Texas. In *The Boiler Site (41WB557): Utilization of an Upland Setting Over the Last 4200 Years, Webb County, Texas*, by J. M. Quigg, S. Pritchard, and G. Smith, pp. D-1 through D-36. TRC Technical Report No. 27277, TRC Mariah Associates, Inc., Austin and Texas Department of Transportation, environmental Affairs Division, Archeological Studies Program, Report No. 45.
- 2007 Results of Microscopic Use-Wear and Residue Analyses from the Varga Site 41ED28, Texas. In *The Varga Site: A Multicomponent, Stratified Campsite in the Canyonlands of Edwards County, Texas*, by J. M. Quigg, J. D. Owens, P. M. Matchen, G. D. Smith, R. A. Ricklis, M. C. Cody, and C. D. Frederick, pp. 831-871. Texas Department of Transportation, Environmental Affairs Division, Archeological Studies Program Report No. 110, and TRC Environmental Corporation, TRC Technical Report No. 35319.
- Harris, E. S.  
1985 *An Archaeological Study of the Timmeron Rockshelter (41HY95), Hays County, South Central Texas*. Southern Texas Archaeological Association, Special Publication No. 4, San Antonio.
- Henderson, J.  
2001 *Excavations at the Rainey Site (41BN33): A Late Prehistoric Sinkhole Site in Bandera County, Texas*. Texas Department of

- Transportation, Environmental Affairs Division, Archeological Studies Program, Report 5, Austin.
- Henry A. G., H. F. Hudson, and D. R. Piperno  
2009 Changes in Starch Grain Morphologies from Cooking. *Journal of Archaeological Science* 36: 915-922.
- Hester, T. R.  
1971 Archeological Investigations at the La Jita Site, Val Verde County, Texas. *Bulletin of the Texas Archeological Society* 42:51-148.
- 1978 Notes on the Edwards Arrow Point Type. *La Tierra* 5(4):21-31
- Hester, T. R. and M. B. Collins  
1969 Burials from Frisch Auf! Site: 41FY42. *Texas Journal of Science* 203:261-272.
- Hester, R. H., D. Gilbow, and A. D. Albee  
1973 A Functional Analysis of "Clear Fork" Artifacts from the Rio Grande Plain, Texas. *American Antiquity* 38(1):90-96.
- Hester, R. H., F. Asarao, F. H. Stross, and R. D. Giauque  
2000 Source Analysis of an Obsidian Flake from the Bessie Kruze Site (41WM13). In *Life and Death as Seen at the Bessie Kruze Site (41WM13) on the Blackland Prairie of Williamson County, Texas*, by L. Johnston, pp. 237-238. Texas Department of Transportation, Environmental Affairs Division, Archeological Studies Program Report No. 22, Austin.
- Hofman, J. L., L. C. Todd, and M. B. Collins  
1991 Identification of Central Edwards Chert at the Folsom and Lindenmeier Sites. *Plains Anthropologist* 36(137):297-308.
- Houk, B. A., K. A. Miller, and E. R. Oksanen  
2008 *The Gatlin Site (41KR621): Investigating Archaic Lifeways on the Southern Edwards Plateau of Central Texas*. SWCA Environmental Consultants, SWCA Cultural Resources Report No. 149 and Texas Department of Transportation, Archeological Studies Program Report No. 108.
- Howard, C. D.  
1973 A Study of the Clear Fork Gouge. *Bulletin of the Texas Archeological Society* 44:51-60.
- Howells, R. G., R. W. Neck, and H. D. Murray  
1996 *Freshwater Mussels of Texas*. Texas Parks and Wildlife Department Press, Austin.
- Hudler, D. B.  
1997 *Determining Clear Fork Tool Function Through Use-wear Analysis: A Discussion of Use-wear Methods and Clear Fork Tools*. Studies in Archeology 25. Texas Archeological Research Laboratory, The University of Texas at Austin.
- Huebner, J. A. and A. G. Comuzzie  
1992 *The Archeology and Bioarcheology of Blue Bayou: A Late Archaic and Late Prehistoric Mortuary Locality in Victoria County, Texas*. Studies in Archeology 9, Texas Archeological Research Laboratory, The University of Texas at Austin.
- Iriarté, J., I. Holst, O. Marozzi, C. Listopad, E. Alonso, A. Rinderknecht, and J. Montaña  
2004 Evidence for cultivar adoption and emerging complexity during the mid-Holocene in the La Plata basin. *Nature* 432:614-617.

- Jelks, E. B.  
1962 *The Kyle Site: A Stratified Central Texas Aspect Site in Hill County, Texas.* Archaeology Series, No. 5, Department of Anthropology, The University of Texas, Austin.
- Johnson, L., Jr.  
1964 *The Devil's Mouth Site: A Stratified Campsite at Amistad Reservoir, Val Verde County, Texas.* Archaeology Series, No. 6. Department of Anthropology, The University of Texas, Austin.
- 1991 *Early Archaic Life at the Sleeper Archaeological Site, 41BC65 of the Texas Hill County Blanco County, Texas.* Texas Department of Highways and Public Transportation, Highway Design Division, Publications in Archaeology, Report No. 39, Austin.
- 1994 *The Life and Times of Toyah-Culture Folk: As Seen from the Buckhollow Encampment, Site 41KM16, of Kimble County, Texas.* Texas Department of Transportation and Texas Historical Commission, Office of the State Archeologist Report 38.
- 2000 *Life and Death as Seen at the Bessie Kruse Site (41WM13) on the Blackland Prairie of Williamson County, Texas.* Texas Department of Transportation, Environmental Affairs Division, Archeological Studies Program Report No. 22, Austin.
- Johnson, L. and G. T. Goode  
1994 A New Try at Dating and Characterizing Holocene Climates as well as Archeological Periods, on the Eastern Edwards Plateau. *Bulletin of the Texas Archeological Society* 65:1-51.
- 1995 *Past cultures and Climates at Jonas Terrace, 41ME29, Medina County, Texas.* Office of the State Archeologist, Report 40. Texas Historical Commission, Austin.
- Karbula, J. W.  
2003 The Toyah Bluff Site (41TV441)- Changing Notions of Late Prehistoric Subsistence in the Blackland Prairie Along the Eastern Edge of the Edwards Plateau, Travis County, Texas. *Bulletin of the Texas Archeological Society* 74:55-81.
- Karbula, J. W., J. A. Campbell, and B. M. Jones  
2011 The Berdoll Site: An Early Archaic Camp on Onion Creek, Travis County, Texas. *Bulletin of the Texas Archeological Society* 82:135-173.
- Kenmotsu, N. A. and D. K. Boyd, editors  
2012 *The Toyah Phase of Central Texas: Late Prehistoric Economic and Social Processes.* Texas A&M University Press, College Station.
- Kerr, A. C. and S. W. Dial  
1998 Chapter 14, Statistical Analysis of Unfluted Lanceolate and Early Bifurcate Stem Projectile Points. In *Wilson-Leonard An 11,000-year Archeological Record of Hunter-Gatherers in Central Texas.* Volume II assembled and edited by M. B. Collins, pp. 447-505. Studies in Archeology 31, Texas Archeological Research Laboratory, The University of Texas at Austin, and Archeology Studies Program, Report 10, Texas Department of Transportation, Environmental Affairs Division.
- Kibler, K. W.  
2012 The Role of Exotic Materials in Toyah Assemblages in a Late Prehistoric (Toyah) Period in Texas. In *Toyah Phase of Central*



- Texas, Late Prehistoric Economic and Social Processes*, edited by N. A. Kenmotsu and D. K. Boyd, pp. 76-89. Texas A&M University Press, College Station.
- Kibler, K. W. and A. M. Scott  
2000 *Archaic Hunters and Gatherers of the Balcones Canyonlands: Data Recovery at the Cibolo Crossing Site (41BX377), Bexar County, Texas*. Reports of Investigations, Number 126, Prewitt and Associates, Inc., Austin.
- Kittleman, L. R.  
1994 A Microscopical Analysis of Potsherds from the Toyah Culture of Texas. In *The Life and Times of Toyah-Culture Folk: As Seen from the Buckhollow Encampment, Site 41Km16, of Kimble County, Texas*, by L. Johnson pp. 308-315. Texas Department of Transportation and Texas Historical Commission, Office of the State Archeologist Report 38.
- Kochel, R. C., V. R. Baker, and P. C. Patton  
1982 Paleohydrology of Southwestern Texas. *Water Resources Research* 18(4):1165-1183.
- Kwiatkowski, S.  
1992 The Rye Creek Flotation and Macrobotanical Analyses. In *The Rye Creek Project: Archaeology in the Upper Tonto Basin. Volume 2: Artifact and Specific Analyses*, pp. 325-375. Anthropological Papers No. 11. Center for Desert Archeology, Tucson.
- Lintz, C., A. C. Treece, and F. Oglesby  
1995 The Early Archaic Structure at the Turkey Bend Ranch Site (41CC112), Concho County. In *Advances in Texas Archeology: Contributions from Cultural Resource Management* (Chapter 5), edited by J. E. Bruseth and T. K. Perttula, pp. 155-186. Cultural Resources Management Report 5, Texas Historical Commission.
- Lord, K. J.  
1984 The Zooarchaeology of Hinds Cave (41VV456), Val Verde County, Texas. Unpublished Master's thesis, Department of Anthropology, Texas A&M University, College Station.
- Loy, T. H.  
1994 Residue Analysis of Artifacts and Burned Rock from the Mustang Branch and Barton Sites (41HY209 and 41HY202). In *Archaic and Late Prehistoric Human Ecology in the Middle Onion Creek Valley, Hays County, Texas*, by R. A. Ricklis, and M. B. Collins, pp. 607-627. Studies in Archeology 19, Texas Archeological Research Laboratory, The University of Texas at Austin.
- Luke, C. J.  
1980 *Continuing Archaeology on State Highway 16 in Kerr County Texas: The Excavations of the Sheep Site (41KR109) and the Wounded Eye Site (41KR107)*. Texas Department of Highways and Public Transportation, Highway Design Division, Publications in Archaeology, Report No. 16, Austin.
- Lukowski, P. D.  
1988 *Archaeological Investigations at 41BX1, Bexar County, Texas*. Center for Archaeological Research, The University of Texas at San Antonio, Archaeological Survey Report, No. 135.
- MacMasters, M. M.  
1964 Microscopic Techniques for Determining Starch Granule Properties. In *Methods in*

- Carbohydrate Chemistry*, edited by R. L. Whistler, pp. 233-240. Academic Press.
- Mahoney, R. B., H. J. Shafer, S. A. Tomka, L. C. Nordt, and R. P. Mauldin  
2003a *Royal Coachman (41CM111), An Early Middle Archaic Site along Cordova Creek in Comal County, Texas*. Texas Department of Transportation, Environmental Affairs Division, Archeological Studies Program Report No. 49 and the Center for Archaeological Research, The University of Texas at San Antonio, Archaeological Survey Report No. 332.
- Mahoney, R. B., S. A. Tomka, R. P. Mauldin, H. J. Shafer, L. C. Nordt, R. D. Greaves, and R. R. Galdeano  
2003b *Data Recovery Excavations at 41MM340: A Late Archaic Site along Little River in Milam County, Texas*. Texas Department of Transportation, Environmental Affairs Division, Archeological Studies Program, Report No. 54, and Center for Archaeological Research, The University of Texas at San Antonio, Archaeological Survey Report, No. 340.
- Malainey, M. E. and K. L. Malisza  
2007 Analysis of the Fatty Acid Compositions of Archaeological Pottery and Rock Residues from the Varga Site (41ED28). In *The Varga Site: A Multicomponent, Stratified Campsite in the Canyonlands of Edwards County, Texas*, by J. M. Quigg, J. D. Owens, P. M. Matchen, G. D. Smith, R. A. Ricklis, M. C. Cody, and C. D. Frederick, pp. 993-1024. Texas Department of Transportation, Environmental Affairs Division, Archeological Studies Program Report No. 110, and TRC Environmental Corporation, TRC Technical Report No. 35319.
- Malof, A. F. and M. S. Taylor  
2011 A Terminal Archaic Burial from the Central Colorado River Basin, Travis County, Texas. *Bulletin of the Texas Archeological Society* 82:251-280.
- Masson, M. A. and M. W. Holderby  
1994 Subsistence Patterns at 41HY209 and 41HY202: An Analysis of Vertebrate Faunal Remains. In *Archaic and Late Prehistoric Human Ecology in the Middle Onion Creek Valley, Hays County, Texas*, by R. A. Ricklis, and M. B. Collins, pp. 403-489. Studies in Archeology 19, Texas Archeological Research Laboratory, The University of Texas at Austin.
- Matchen, P. M. and J. M. Quigg  
2007 *Bell/Andice Peoples of the Middle Archaic: An Examination of Subsistence Strategies in Texas*. Paper presented as the 72<sup>nd</sup> Annual Meeting of the Society of American Archeology, Austin.
- Mauldin, R. P., D. L. Nickels, and C. J. Broehm  
2003 *Archaeological Testing to Determine the National Register Eligibility Status of Eighteen Prehistoric Sites on Camp Bowie, Brown County, Texas*. Volumes 1 and 2. Center for Archaeological Research, The University of Texas at San Antonio, Archaeological Survey Report, No. 334.
- Mauldin, R. P., S. A. Tomka, and H. J. Shafer  
2004 *Millican Bench (41TV163): A Multicomponent Site in Travis County, Texas*. Texas Department of Transportation, Environmental Affairs Division, Archeological Studies Program, Report No. 66 and Center for Archaeological Research, The University of Texas at San Antonio, Archaeological Survey Report, No. 351.

- Mauldin, R. P., J. Thomson, and L. Kemp  
2012 Reconsidering the Role of Bison in the Terminal Late Prehistoric (Toyah) Period in Texas. In *Toyah Phase of Central Texas, Late Prehistoric Economic and Social Processes*, edited by N. A. Kenmotsu and D. K. Boyd, pp. 90-110. Texas A&M University Press, College Station.
- McKinney, W. W.  
1981 Early Archaic Adaptations in Central and Southwestern Texas: The Problem of the Paleoindian-Archaic Transition. *Bulletin of the Texas Archeology Society* 52:91-120.
- McNatt, L., M. D. Freeman, P. Schuchert, M. Howard, S. A. Tomka, C. G. Ward, and C. Beceiro  
2001 *Colorado Bend State Park: San Saba and Lampasas Counties, Texas*. Texas Parks and Wildlife Department, Cultural Resources Program, Austin.
- Mehalchick, G. and K. W. Kibler  
2008 *Hunters and Gatherers of the North Bosque River Valley: Excavations at the Baylor, Britton, McMillan, and Higginbotham Sites, Waco Lake, McLennan County, Texas*. Reports of Investigations, Number 156, Prewitt and Associates, Inc., Austin.
- Mehalchick, G., T. Myers, K. W. Kibler, and D. K. Boyd  
1999 "Val Verde on the Sunny Rio Grande": *Geoarcheological and Historical Investigations at San Felipe Springs, Val Verde County, Texas*. Reports of Investigations, Number 122, Prewitt and Associates, Inc., Austin.
- Mehalchick, G., D. K. Boyd, K. W. Kibler, and C. W. Ringstaff  
2004 *Shifting Sands and Geophytes: Geoarcheological Investigations at Paluxy Site on Fort Hood, Texas*. United States Army Fort Hood, Archeological Resource Management Series, Research Report No. 48.
- Nickels, D. L., C. B. Bousman, J. D. Leach, and D. A. Cargill  
2001 *Test Excavations at the Culebra Creek Site, 41BX126, Bexar County, Texas*. Archaeological Survey Report, No. 265, Center for Archaeological Research, The University of Texas at San Antonio and Archeological Studies Program, Report 3, Environmental Affairs Division, Texas Department of Transportation, Austin.
- Nordt, L. C.  
1992 *Archaeological Geology of the Fort Hood Military Reservation, Ft. Hood, Texas*. Archaeological Resource Management Series, Research Report Number 25, United States Army, Fort Hood, Texas.
- 1993 *Additional Geoarcheological Investigations at the Fort Hood Military Reservation, Ft. Hood, Texas*. Archaeological Resource Management Series, Research Report Number 28, Addendum to Research Report Number 25, United States Army, Fort Hood, Texas.
- Oksanen, E. R. (assembled by)  
2011 *Archaeological Investigations at the Ice House Site 41HY161: Early Archaic Technology, Subsistence, and Settlement along the Balcones Escarpment, Hays County Texas*. Archaeological Studies Report No. 14, Center for Archaeological Studies, Texas State University - San Marcos.
- Oksanen, E. R., M. C. Cody, and K. A. Miller  
2008 Chapter 8: Occupation Zone 1. In *The Gatlin Site (41KR621): Investigating Archaic Lifeways on the Southern Edwards*

- Plateau of Central Texas*, by B. A. Houk, K. A. Miller, and E. R. Oksanen, pp. 8-1 through 8-19. SWCA Environmental Consultants, SWCA Cultural Resources Report No. 149 and Texas Department of Transportation, Archeological Studies Program Report No. 108.
- Parry, W. J. and R. L. Kelly  
1987 Expedient Core Technology and Sedentism. In *The Organization of Core Technology*, edited by J. K. Johnson and C. A. Morrow, pp. 285-304. Westview Press, Boulder.
- Pearl, F. B.  
1997 Geoarchaeological Investigations of the Upper Lampasas River, Texas. Unpublished Master's thesis, Texas A&M University, College Station.
- Pearsall, D. M., K. Chandler-Ezell, and J. A. Zeidler  
2004 Maize in ancient Ecuador: results of residue analysis of stone tools from the Real Alto site. *Journal of Archaeological Science* 31:423-442.
- Perry, L.  
2001 Prehispanic subsistence in the middle Orinoco basin: starch analyses yield new evidence. Unpublished Ph.D. dissertation, Southern Illinois University Carbondale, Illinois.  
2002 Starch analyses indicate multiple functions of quartz "manioc" grater flakes from the Orinoco basin, Venezuela. *Interciencia* 27:635-639.  
2004 Starch analyses reveal the relationship between tool type and function: an example from the Orinoco valley of Venezuela.
- Journal of Archaeological Science* 31:1069-1081.
- Perry, L. and J. M. Quigg  
2011a Starch Remains and Stone Boiling in the Texas Panhandle, Part I: The Pipeline, Corral, and Pavilion Sites. *Plains Anthropologist* 56(218):95-107.  
2011b Starch Remains and Stone Boiling in the Texas Panhandle, Part II: Identifying Wildrye (*Elymus* spp.). *Plains Anthropologist* 56(218):109-119.
- Perry, L., D. Sandweiss, D. R. Piperno, K. Rademaker, M. Malpass, A. Umire, and P. de la Vera  
2006 Early Maize Agriculture and Interzonal Interaction in Southern Peru. *Nature* 440(2):76-78.
- Perry, L., R. Dickau, S. Zarrillo, I. Holst, D. M. Pearsall, D. R. Piperno, M. J. Berman, R. Cooke, K. Rademaker, A. J. Ranere, J. S. Raymond, D. Sandweiss, F. Scaramelli, K. Tarble, and J. Zeidler  
2007 Starch fossils and the domestication and dispersal of chili peppers (*Capsicum* spp. L.) in the Americas. *Science* 315:986-988.
- Perttula, T. K.  
1992 *The Caddo Nation*. University of Texas Press. Austin.  
1995 The Present and Future of Texas Prehistoric Archeology: An Introduction to the 1995 BTAS. *Bulletin of the Texas Archeological Society* 66:7-15.  
2001 Prehistoric Ceramic Sherds from 41MM341. In *National Register Eligibility Testing of 41MM340 and 41MM341, along Little River, Milam County, Texas*, by R. B. Mahoney and S. A. Tomka, pp. 124-125. Archeological Studies Program, Report

- No. 30. Environmental Affairs Division, Texas Department of Transportation and Archaeological Survey Report No. 303, Center for Archaeological Research, The University of Texas at San Antonio.
- 2004 *The Prehistory of Texas*. Texas A&M University Press, College Station.
- Perttula, T. K., S. A. Iruegas, and H. Neff  
2003 *Caddoan Pottery in Central Texas: Geochemical Analyses of Ceramics from Fort Hood and Vicinity*. United States Army Fort Hood, Archeological Resource Management Series, Research Report No. 51.
- Peter, D. E., T. R. Hays, and M. A. Demuynck  
1982 The Archaeology of the San Gabriel Reservoir Districts. In *Archaeological Investigations at the San Gabriel Reservoir Districts, Central Texas*, Volume 2, edited by T. R. Hays, pp. 16-1-17-30. Archaeology Program, Institute of Applied Sciences, North Texas State University, Denton.
- Piperno D. R. and I. Holst  
1998 The Presence of Starch Grains on Prehistoric Stone Tools from the Humid Neotropics: Indications of Early Tuber Use and Agricultural in Panama. *Journal of Archeological Science* 25:765-776.
- Piperno, D. R., A. J. Ranere, I. Holst, and P. Hansell  
2000 Starch grains reveal early root crop horticulture in the Panamanian tropical forest. *Nature* 407: 894-897.
- Prewitt, E.  
1966 Preliminary Report on the Devil's Rockshelter. *Texas Journal of Science* 18(2):206-224.
- 1974 *Archeological Investigations at the Loeve-Fox Site, Williams County, Texas*. Research Report 49. Texas Archeological Survey, The University of Texas at Austin.
- 1981 Cultural Chronology in Central Texas. *Bulletin of the Texas Archeological Society* 52:65-90.
- 1982a Archeological Investigations at the Loeve-Fox and Loeve Tombstone Bluff Sites in the Granger Lake District of Central Texas. In *Archaeological Investigations at the San Gabriel Reservoir Districts, Central Texas*, edited by T. R. Hays, Volume 4. Institute of Applied Sciences, North Texas State University, Denton.
- 1982b *Archeological Investigations at the Loeve-Fox Site, Williamson County, Texas*. Reprints in Archeology Number 1, Prewitt and Associates, Inc., Austin.
- 1985 From Circleville to Toyah: Comments on Central Texas Archeology. *Bulletin of the Texas Archeological Society* 54:201-238.
- 1995 Distributions of Typed Projectile Points in Texas. *Bulletin of the Texas Archeological Society* 66:83-173.
- Quigg, J. M.  
1997 Bison Processing at the Rush Site, 41TG346, and Evidence for Pemmican Production in the Southern Plains. *Plains Anthropologist* 42(159):145-161, Memoir 29.
- Quigg, J. M. and G. L. Ellis  
1994 Burned Rock Mound Chronometric Investigations. In *Archeological Investigations on 571 Prehistoric Sites at Fort Hood, Bell and Coryell Counties, Texas*, edited by W. N. Trierweiler, pp.

- 203-274. United States Army Fort Hood, Archeological Resource Management Series, Research Report No. 31.
- Quigg, J. M. and J. Peck  
1995 *The Rush Site (4ITG346): A Stratified Late Prehistoric Locale in Tom Green County, Texas*. Technical Report No. 816C. TRC Mariah Associates, Inc., Austin.
- Quigg, J. M. and C. D. Frederick  
2005 *Archeological Testing of TxDOT Right-of-Way Along FM 580W Over Lynch Creek, Lampasas County, Texas: Interim Report*. Submitted to and on file with Texas Department of Transportation, Environmental Affairs Division, Archeological Studies Program, and TRC Interim Report No. 43243.
- Quigg, M. and P. Dering  
2007 *Late Prehistoric Subsistence Economy on the Periphery of the Southern Plains*. Paper presented at the 72<sup>nd</sup> Annual Meeting of the Society of American Archeology, Austin.
- Quigg, J. M., P. M. Matchen, C. D. Frederick, and E. Schroeder  
2007a *Data Recovery at 4ITV2161, Travis County, Texas: Interim Report*. Submitted to and on file with Texas Department of Transportation, Environmental Affairs Division, Archeological Studies Program, and TRC Interim Report No. 51831.
- Quigg, J. M., C. D. Frederick, P. M. Matchen, and K. DuBois  
2010 *Landis Property: Data Recovery at Three Prehistoric Sites (4IPT185, 4IPT186, and 4IPT245) in Potter County, Texas*. TRC Report No. 150832. Manuscript on file with TRC Environmental Corporation in Austin and Bureau of Land Management, Santa Fe.
- Quigg, J. M., P. M. Matchen, C. D. Frederick, and R. A. Ricklis  
2011b *Root-Be-Gone (41YN452): Data Recovery of Late Archaic Components in Young County, Texas*. Texas Department of Transportation, Environmental Affairs Division, Archeological Studies Program, Report No. 135 and TRC Environmental Corporation, Austin, TRC Technical Report No. 171219.
- Quigg, J. M., R. A. Ricklis, P. M. Matchen, and J. T. Abbott  
2013b *Data Recovery at 41MI96 in Mills County, Texas*. Texas Department of Transportation, Environmental Affairs Division, Archeological Studies Program, Report No. 150 and TRC Environmental Corporation, TRC Technical Report No. 192832.
- Quigg, J. M., C. Lintz, G. Smith, D. DeMar, and J. D. Owens  
2011a *Cultural Resource Investigations to Offset Mechanical Impacts to the Clear Creek Golf Course Site (41CV413), Fort Hood, Texas*. TRC Technical Report No. 02353 prepared for SEMA Golf, LLC and United States Army Fort Hood, Archeological Resource Management Series, Research Report No. 60.
- Quigg, J. M., J. D. Owens, P. M. Matchen, G. D. Smith, R. A. Ricklis, M. C. Cody, and C. D. Frederick  
2007b *The Varga Site: A Multicomponent, Stratified Campsite in the Canyonlands of Edwards County, Texas*. Texas Department of Transportation, Environmental Affairs Division, Archeological Studies Program Report No. 110 and TRC Environmental Corporation, TRC Technical Report No. 35319.

- Quigg, J. M., J. Peck, C. Lintz, A. C. Treece, C. D. Frederick, R. Clem, G. L. Ellis, P. Schuchert, and J. T. Abbott  
1996 *Early Archaic use of the Concho River Terraces: Cultural Resource Investigations at 41TG307 and 41TG309 Tom Green County, Texas*. TRC Mariah Associates Inc. Technical Report No. 11058.
- Quigg, J. M., P. M. Matchen, C. D. Frederick, R. A. Ricklis, B. Gregory, D. Maki, and M. Bateman  
2013a *Long View (41RB112): Data Recovery of Two Plains Village Components in Roberts County, Texas*, Volumes I and II. Texas Department of Transportation, Environmental Affairs Division, Archeological Studies Program, Report No. 147 and TRC Technical Report No. 174542 and 46557, TRC Environmental Corporation, Austin.
- Reichert, E. T.  
1913 *The Differentiation and Specificity of Starches in Relation to Genera, Species, etc.* Carnegie Institute, Washington DC.
- Reese-Taylor, K.  
1993 Petrographic Studies of Ceramic Pastes. In *Cultural Resource Investigations in the O. H. Ivie Reservoir, Concho, Coleman, And Runnels Counties, Texas, Volume IV, Data Recovery Results from Ceramic Sites*, by A. C. Treece, C. Lintz, W. N. Trierweiler, J. M. Quigg, and K. A. Miller, pp. I-1 to I-11. Mariah Associates Inc., Technical Report 346-IV, Austin.
- 1995 Petrographic Analysis of A Toyah Phase Ceramic Assemblage. In *The Rush Site (41TG346): A Stratified Late Prehistoric Locale in Tom Green County, Texas*, by J. M. Quigg and J. Peck, pp. F-1 to F-16. Technical Report No. 816C, TRC Mariah Associates Inc., Austin.
- Reese-Taylor, K., J. Hageman, and R. A. Ricklis  
1994 Preliminary Paste Analysis of Ceramic Samples from the Mustang Branch Site (41HY209) and Barton Site (41HY202). In *Archaic and Late Prehistoric Human Ecology in the Middle Onion Creek Valley, Hays County, Texas, Volume 2: Topical Studies*, by R. A. Ricklis and M. B. Collins, pp. 549-568. Studies in Archeology 19, Texas Archeological Research Laboratory, The University of Texas at Austin.
- Ricklis, R. A.  
1988 Archeological Investigations at the McKinzie Site (41NU221), Nueces County, Texas: Description and Contextual Interpretations. *Bulletin of the Texas Archeological Society* 58:1-76
- 1992a The Spread of a Late Prehistoric Bison Hunting Complex in Texas: Evidence from the South-Central Coastal Prairie of Texas. *Plains Anthropologist* 37(140):261-273.
- 1992b Aboriginal Karankawan Adaptation and Colonial Period Acculturation: Archeological and Ethnohistorical Evidence. *Bulletin of the Texas Archeological Society* 62:211-243.
- 1993 *A Model of Holocene Environmental and Human Adaptive Change on the Central Texas Coast, Geoarchaeological Investigations at White's Point, Nueces Bay, and Surrounding Area*. Coastal Archaeological Studies, Inc., Corpus Christi.
- 1994 Toyah Components: Evidence for Occupation in the Project Area During the Latter Part of the Late Prehistoric Period. In *Archaic and Late Prehistoric Human Ecology in the Middle Onion creek Valley*,

- Hays County, Texas, Volume 1, Archeological Components*, by R. A. Ricklis and M. B. Collins, pp. 207-316. *Studies in Archeology* 19, Texas Archeological Research Laboratory, The University of Texas at Austin.
- Ricklis, R. A. and M. B. Collins  
1994 *Archaic and Late Prehistoric Human Ecology in the Middle Onion Creek Valley, Hays County, Texas—Volume 1, Archeological Components*. *Studies in Archeology* 19, Texas Archeological Research Laboratory, The University of Texas at Austin.
- Ricklis, R. A. P. M. Matchen, and J. M. Quigg  
2007 *Toward Clarification of the Late Prehistoric of East-Central Texas: A Research Design for Analysis of Archeological Materials from Two Sites in Lampasas County, Texas (41LM50 & 41LM51)*. Prepared for Texas Department of Transportation, Environmental Affairs Division, by TRC Environmental Corporation, Austin.
- Robinson, D. G.  
1999 Appendix C: Petrographic Analysis of Plainware Pottery from 41VV444. In *“Val Verde on the Sunny Rio Grande”*: *Geoarcheological and Historical Investigations at San Felipe Springs, Val Verde County, Texas*, by G. Mehalchick, T. Myers, K. W. Kibler, and D. K. Boyd, pp. 179-189. Reports of Investigations, Number 122, Prewitt and Associates, Inc., Austin.
- 2007 Appendix D: Petrographic Analysis of Toyah Ceramics from the Varga Site, 41ED28, and Comparative Sites. In *The Varga Site: A multicomponent, Stratified Campsite in the Canyonlands of Edwards County, Texas*, by J. M. Quigg, J. D. Owens, P. M. Matchen, G. D. Smith, R. A. Ricklis, M. C. Cody, and C. D. Frederick, pp. 872-889. Texas Department of Transportation, Environmental Affairs Division, Archeological Studies Program, Report No. 110 and TRC Environmental Corporation, TRC Technical Report No. 35319.
- Root, M. J., D. E. Ferguson, and D. R. Harro  
2008 Functional Analysis of Selected Tools from 41KR 621. In *The Gatlin Site (41KR621): Investigating Archaic Lifeways on the southern Edwards Plateau of Central Texas*. SWCA Environmental Consultants, SWCA Cultural Resources Report No. 149 and Texas Department of Transportation, Archeological Studies Program Report No. 108.
- Schoeneberger, P. J., D. A. Wysocki, E. C. Benham, and W. D. Broderson (editors)  
2002 *Field Book for Describing and Sampling Soils*. Version 2.0. Natural Resources Conservation Service, National Soil Survey Center, Lincoln.
- Schroeder, E. A.  
2011 The Armstrong Site: A Transitional Archaic Occupation along the Eastern Balcones Escarpment. *Bulletin of the Texas Archeological Society* 82:117-134.
- Schroeder, E. A. and E. R. Oksanen  
2002 *Data Recovery at the Armstrong Site (41CW54) Caldwell County, Texas*. Volumes I and II. Paul Price Associates, Inc., PPA Cultural Resources Report Number 0284, Austin.
- Shafer, H. J.  
1963 Test Excavations at the Youngsport Site: A Stratified Terrace Site in Bell County,



- Texas. *Bulletin of the Texas Archeological Society* 34:57-81.
- 1973 Lithic Technology at the George C. Davis Site, Cherokee County, Texas. Unpublished Ph.D. dissertation, Department of Anthropology, The University of Texas at Austin.
- 2006 *People of the Prairie: A Possible Connection to the Davis Site Caddo*. Texas Department of Transportation, Environmental Affairs Division, Archeological Studies Program, and Prewitt and Associates, Inc., Austin.
- Shafer, H. J. and V. M. Bryant, Jr.  
1977 *Archeological and Botanical Studies at Hinds Cave, Val Verde County, Texas*. Annual Report of Research, National Science Foundation, Texas A&M University, Anthropology Laboratory, Special Series No. 1.
- Shaffer, B. S.  
1994 Appendix III, Analysis of the Vertebrate Remains. In *The Life and Times of Toyah-Culture Folk: As Seen from the Buckhollow Encampment, Site 41KM16, of Kimble County, Texas*, by L. Johnson, pp. 295-307. Texas Department of Transportation and Texas Historical Commission, Austin.
- Simons, H. and W. E. Moore (compilers)  
1997 *Archeological Bibliography for the Central Texas Region of Texas*. Office of the State Archeologist Special report 36, Texas Historical Commission, Austin.
- Smith, B. N. and W. V. Brown  
1973 The Kranz Syndrome in the Gramineae as Indicated by Carbon Isotope Ratios. *American Journal of Botany* 60(6Z):505-513.
- Sollberger, J. T.  
1971 A Technological Study of Beveled Knives. *Plains Anthropologist* 16:209-218.
- Speakman, R. J. and M. D. Glascock  
2007 Instrumental Neutron Activation Analysis of Pottery from the Lorenzo Mission (41RE1), San Juan Mission (41BX5), and Varga (41ED28) in Real, Bexar and Edwards Counties, Texas. In *The Varga Site: A multicomponent, Stratified Campsite in the Canyonlands of Edwards County, Texas*, by J. M. Quigg, J. D. Owens, P. M. Matchen, G. D. Smith, R. A. Ricklis, M. C. Cody, and C. D. Frederick, pp. 1090-1106. Texas Department of Transportation, Environmental Affairs Division, Archeological Studies Program Report No. 110 and TRC Environmental Corporation, TRC Technical Report No. 35319.
- Sorrow, W. M., H. J. Shafer, and R. E. Ross  
1967 *Excavations at Stillhouse Hollow Reservoir*. Papers of the Texas Archeological Salvage Project, No. 11, Austin.
- Steele, D. G.  
2000 Analysis of the Human Remains from the Bessie Kruze Site (41WM13). In *Life and Death as Seen at the Bessie Kruze Site (41WM13) on the Blackland Prairie of Williamson County, Texas*, by L. Johnston, pp. 227-235. Texas Department of Transportation, Environmental Affairs Division, Archeological Studies Program Report No. 22, Austin.
- Story, D. A.  
1990 Cultural History of the Native Americans. In *The Archeology and Bioarcheology of the Gulf Coastal Plain: Volume I*, by D. A. Story, J. A. Guy, B. Burnett, M. D.

- Freeman, J. C. Rose, D. G. Steele, G. W. Olive and K. J. Reinhard, pp. 163-366. Arkansas Archeological Survey Research Series No. 38, Fayetteville.
- 1998 The George C. Davis Site: Glimpses into Early Caddoan Symbolism and Ideology. In *The Native History of the Caddo: Their Place in Southeastern Archeology and Ethnohistory*, edited by T. K. Perttula and J. E. Bruseeth, pp. 9-43. Studies in Archeology 30. Texas Archeological Research Laboratory, The University of Texas at Austin.
- Suhm, D. A.
- 1955 Excavations at the Collins Site, Travis County, Texas. *Bulletin of the Texas Archeological Society* 26:7-54.
- 1957 Excavations at the Smith Rockshelter, Travis County, Texas. *Texas Journal of Science* 9(1):26-58.
- Suhm, D. A. and E. B. Jelks (editors)
- 1962 *Handbook of Texas Archeology: Type Descriptions*. The Texas Archaeological Society Special Publication Number One and The Texas Memorial Museum Bulletin Number One, Austin.
- Suhm, D. A., A. D. Krieger, and E. B. Jelks
- 1954 An Introductory Handbook of Texas Archaeology. *Bulletin of the Texas Archeological Society* 25:1-582.
- Texas Department of Transportation (TxDOT)
- 2010 TxDOT Chipped Stone Analytical Protocol Version 2.1, TxDOT Archeological Studies Program, On File with Environmental Affairs Division, Texas Department of Transportation, Austin.
- Thoms, A. V.
- 1992 Late Pleistocene and Early Holocene Regional Land Use Patterns: A Perspective from the Preliminary Results of Archaeological Studies at the Richard Beene Site, 41BX831, Lower Medina River, South Texas. In *Guidebook, 10<sup>th</sup> Annual Meeting, South-Central Friends of the Pleistocene*. Manuscript in author's possession.
- 2007 Archaeological Records at the Richard Beene Site: Summary and Synthesis. In *Archaeological and Paleocological Investigations at the Richard Beene Site 41BX831: South-Central Texas*, edited by A. V. Thoms and R. D. Mandel, pp. 337-380. Reports of Investigations No. 8. Center for Ecological Archaeology, Texas A & M University, College Station.
- Thoms, A. V. and R. D. Mandel, editors
- 2007 *Archaeological and Paleocological Investigations at the Richard Beene Site 41BX831: South-Central Texas*. Reports of Investigations No. 8. Center for Ecological Archaeology, Texas A&M University, College Station.
- Thoms, A. V., D. D. Kuehn, B. W. Olive, J. E. Dockall, P. A. Clabough, and R. D. Mandel
- 1996 Early and Middle Holocene Occupations at the Richard Beene Site: The 1995 Southern Texas Archaeological Association Field School Project. *La Tierra* 23(4):8-36.
- Treece, A. C., C. Lintz, W. N. Trierweiler, J. M. Quigg, and K. A. Miller
- 1993a *Cultural Resource Investigations in the O. H. Ivie Reservoir, Concho, Coleman, and Runnels Counties, Texas. Volume III: Data Recovery Results from Non-Ceramic Sites*. Technical Report No. 346-III. Mariah Associates, Inc., Austin.

- 1993b *Cultural Resource Investigations in the O. H. Ivie Reservoir, Concho, Coleman, and Runnels Counties, Texas. Volume IV: Data Recovery Results from Ceramic Sites.* Technical Report No. 346-IV. Mariah Associates, Inc., Austin.
- Turner, E. S. and T. R. Hester  
1993 *A Field Guide to Stone Artifacts of Texas Indians.* First Edition. Gulf Publishing Company, Houston.
- 1999 *A Field Guide to Stone Artifacts of Texas Indians.* Third Edition. Texas Monthly Field Guide Series. Gulf Publishing Company, Houston.
- Turner, E. S., T. R. Hester, and R. L. McReynolds  
2011 *Stone Artifacts of Texas Indians.* Completely revised 3<sup>rd</sup> Edition. Taylor Trade Publishing, Maryland.
- Turpin, S. A.  
1991 Time out of Mind: The Radiocarbon Chronology of the Lower Pecos River Region. In *Papers on Lower Pecos Prehistory*, edited by S. A. Turpin, pp. 1-49. Studies in Archeology 8. Texas Archeological Research Laboratory, The University of Texas at Austin.
- Turpin, S. A. and D. G. Robinson  
1998 Infierno Phase Pottery of the Lower Pecos River Region. *Bulletin of the Texas Archeological Society* 69:89-97.
- Valastro, S., Jr. and E. M. Davis  
1970 University of Texas at Austin Radiocarbon Dates VII. *Radiocarbon* 12(1):249-280).
- Watt, F. H.  
1956 Archeological Materials from the Asa Warner Sites. *Central Texas Archeologist* 7:6-29.
- Weir, F. A.  
1976 The Central Texas Archaic. Unpublished Ph.D. dissertation, Department of Anthropology, Washington State University, Pullman.
- Wesolowsky, A. B., T. R. Hester, and D. R. Brown  
1976 Archeological Investigations at the Jetta Court Site (41TV151) Travis County, Texas. *Bulletin of the Texas Archeological Society* 47:25-87.
- Whittaker, J.C.  
1994 Flintknapping: Making and Understanding Stone Tools. University of Texas Press, Austin.
- Whittaker, J. C. and E. J. Kaldahl  
2001 *Where the Waste Went: A Knapper's Dump at Grasshopper Pueblo in Lithic Debitage: Context, Form, and Meaning*, edited by W. Andrefsky Jr., pp. 32-60. University of Utah, Salt Lake City.
- Williams-Dean, G.  
1978 Ethnobotany and Cultural Ecology of Prehistoric Man in Southwestern Texas. Unpublished Ph.D. dissertation, Department of Anthropology, Texas A&M University, College Station.
- Williams, M.  
1982 Starch gelatinization: a morphological study of Triticeae and other starches. *Die Stärke* 34: 221-223.

## 13.0 GLOSSARY OF TECHNICAL TERMS

**A Horizon:** The near surface horizon of a natural soil. This is a carbon rich soil horizon characterized by an accumulation of partially decomposed to decomposed organic matter and eluvial loss of constituents such as clays and carbonates, which tend to accumulate in the deeper B horizon. The A horizon represents the upper solum of a soil. Lower case letters with the upper case letter A indicate specific characteristics of that A horizon. An Ab designation indicates the A horizon is buried. An Ap designation indicates a disturbed or anthropically modified soil such as in a plow zone.

**Accelerated Mass Spectrometry (AMS):** Laboratory technique that separates and identifies ions based on their mass to charge ratios. This technique is used in radiocarbon dating tiny particles of carbon in organic remains and residues.

**Accretion:** The process of growth or increase, typically by the gradual accumulation of additional layers or matter.

**Acidic:** Containing acid bearing pollutants.

**Acryloid B-72:** This is a conservation material used to stabilize or glue artifacts together. It is an ethyl methacrylate copolymer.

**A.D.:** Anno domini in Latin. "In the year of our Lord." For example, A.D. 1000 is 1,000 years after Christ. This is generally used when a B.P. radiocarbon date is calibrated to the tree ring results with a calibration formula.

**Agavaceae:** A plant family name that refers to fiber, vascular bundle, or the central stem sections that cannot be specifically identified as agave (*Agave*), yucca (*Yucca*) or sotol (*Dasyilirion*).

**Allostratigraphic Unit:** A depositional unit made up of sediments dating to a similar period of deposition.

**Alluvium:** Clastic sediments, such as sand, silt, or clay deposited by a flowing stream, either in the channel or outside the channel during overbank flooding.

**Antiquities Code of Texas:** This is the state law passed in 1977 to protect and preserve prehistoric and historic cultural resources on lands owned by the State and its political subdivisions.

**Argillins:** These are clay coatings on ped- or pore surfaces.

**Barbule:** A small barb or pointed projection, especially one that fringes the edges of the barbs of feathers. Feather barbules are of two types, pennaceous (making up the flight surface of the feather) and plumulaceous (insulation barbule). Plumulaceous barbules are the most useful for the identification of the type of bird from which the barbule came, but the pennaceous barbules are also useful though generally not as specific as to the type of bird.

**B.C.:** The abbreviation for Before Christ, in contrast to After Christ (A.D.).

**Biface or Bifacial:** A stone tool that has two distinct sides or faces, both of which have been substantially worked and/or flaked. The biface may take the form of many shapes and sizes and used in diverse activities.

**B Horizon:** The lower solum of a natural soil. A B horizon is a mineral soil horizon characterized by an accumulation of constituents such as clays, carbonates or salts, or organic complexes that have been translocated from the A horizon. Common subordinates include lowercase letters such as *t* as Bt, which indicates accumulation of illuvial clays. The lowercase k (Bk) indicates accumulation of carbonate. The lower case w indicates structural or color changes with no significant accumulations of alluvial material.

**Biogenic:** Produced by living organisms or biological processes. Necessary for the maintenance of life processes.

**Bioturbation:** The churning and mixing of sediments by living organisms, including burrowing rodents, insects, worms, and plant roots.

**B.P.:** An abbreviation for before present, which in radiocarbon dating is referenced to the standard year A.D. 1950, which is considered “present”. Generally B.P. dates have not been tree ring corrected using one of the calibration formulas.

**Burned Rock Dump:** A loose cluster of previously heated rocks that exhibits no horizontal patterning to the positions of the rocks and lacks indications of *in situ* heating/burning, such as a prepared basin, lenses of charcoal or ash, and/or the absence of an oxidation rim. Scattered charcoal or other cultural items may be present between or around the burned rocks.

**Burned Rock Midden:** An accumulation of a large quantity of discarded burned rocks previously employed in multiple cooking activities. These accumulations were the results of long extensive cooking episodes generally in association with rock ovens.

**C<sub>3</sub> Plants:** A photosynthetic pathway that most trees and flowering bushes use to assimilate carbon dioxide into their systems. The average carbon isotope of C<sub>3</sub> matter is -26.5‰ with a range from about -19.0‰ to -34.0‰.

**C<sub>4</sub> Plants:** A photosynthetic pathway used by most arid (xeric) grasses and maize (corn) to assimilate carbon dioxide into their systems. The average carbon isotope of C<sub>4</sub> matter is -12.5‰ with a range of -6‰ to -19‰. These plants are more resistant to stress due to lack of water, but more susceptible to cold temperatures.

**C Horizon:** Weathered, but relatively unaltered parent material at the base of a soil profile, generally below the B horizon. This term is roughly synonymous with subsoil, although the latter term is often used to encompass the lower B horizon.

**Calcareous:** Rocks, minerals, or sediment containing calcium carbonates.

**Calcic:** Composed of, containing, derived from, or relating to calcium or lime.

**Calcium:** A chemical element with the symbol Ca and atomic number 20. Calcium is a soft gray alkaline earth metal, and is the fifth most abundant element by mass in the Earth's crust. Calcium is also the fifth most abundant dissolved ion in seawater by both molarity and mass, after sodium, chloride, magnesium, and sulfate.

**Caliche:** A more or less cemented deposit of calcium carbonate in soils of warm-temperate, subhumid to arid areas. Caliche, normally white, occurs as soft, thin layers in the soil or as hard, thick beds just beneath the solum, or it is exposed at the surface by erosion.

**CAM Plants:** A photosynthetic pathway for assimilating carbon dioxide into plants that can change from C<sub>3</sub>-like to C<sub>4</sub>-like pathways depending on the diurnal (day or night) cycle. Most succulent plants such as cactus have crassulacean acid metabolism (CAM) pathways. The carbon isotope values of most CAM plants in Texas such as *Agave lechuguilla* and *Opuntia engelmannii* are similar to the values in C<sub>4</sub> plants (see Eickmeier and Bender 1976).

**Carbonates:** These are rock or mineral classes that include limestone, calcite, ooids, and bioclasts. White carbonate filaments are often observed in C horizons of soils.

**Chalcedony:** A cryptocrystalline variety of quartz or chert. Chalcedony is often a component of other cherts. It may be translucent or semitranslucent, has a wax-like luster, and generally is white, pale blue, gray, blown, or black in color.

**Cheno-am:** A term used in botanical classification that includes the plant family of Chenopodiaceae (goosefoot) and the genus *Amaranthus* (pigweed), with tiny charred seeds that are indistinguishable from each other.

**Chloridoid:** These are short cell phytoliths that are squat and tall saddle-shaped, and occur dominantly

in C<sub>4</sub> grasses such as grama grass (*Bouteloua* sp.) and buffalo grasses (*Bouchloe* sp.). These plants thrive in warm, arid to semiarid regions in which the available soil moisture is very low, thus thrive in the shortgrass prairies during the hot summers.

**Clast:** Any detrital particle of sediment created by the weathering and disintegration of a larger rock mass and transported by water, wind, or ice. Clasts also include discrete particulates created and deposited by volcanic action.

**Clay:** This is mineral sediment particles less than 0.002 millimeters in diameter. As a soil textural class, soil mineral that is 40 percent or more clay, less than 45 percent sand, and less than 40 percent silt.

**Collagen:** This is a group of naturally occurring proteins found in animals, especially in the flesh and connective tissues of vertebrates. It is the main abundant protein in mammals, making up about 25 percent to 35 percent of the whole-body protein content. Collagen, in the form of elongated fibrils, is mostly found in fibrous tissues such as tendon, ligament and skin, and is also abundant in cornea, cartilage, bone, blood vessels, the gut, and intervertebral disc. The fibroblast is the most common cell which creates collagen. In muscle tissue, it serves as a major component of the endomysium. Collagen constitutes 1 to 2 percent of muscle tissue, and accounts for 6 percent of the weight of strong, tendinous muscles. It is converted into gelatin by boiling, which is irreversibly hydrolyzed.

**Colluvium:** Soil material, rock fragments, or both, moved by creep, slide, or local wash that is deposited at the base of steep slopes.

**Commelinaceae:** A family of flowering plants. In less formal contexts, the group is referred to as the dayflower family or spiderwort family. The family counts several hundred species of herbaceous plants.

**Complex:** A group of archeological sites that date to the same time period and that contain similar artifacts. This term expresses a relationship of common cultural or technological traits in assemblages within widespread geographic area.

**Component:** An archeological site or portion of a site that is spatially and chronologically discrete from other accumulations of artifacts. These can be horizontally or vertically differentiated.

**Context:** The association and position of artifacts, materials, and cultural features that are used by archeologists to interpret space, time, and culture.

**Cucurbit:** Any of various mostly climbing or trailing plants of the family *Cucurbitaceae*, which includes the squash, pumpkin, cucumber, gourd, watermelon, and cantaloupe.

**Cumulic Soil:** A soil formed in a setting experiencing relatively slow deposition, so that freshly introduced sediment is incorporated into the A horizon, leading to overthickening of the surface horizon. Cumulic soils are common in alluvial overbank and colluvial settings.

**Dendrite:** An oxide of manganese that has crystallized in a branching pattern as in the dark inclusions in moss agate.

**Deposition:** The accumulation of sediments or gravels laid down by natural agencies such as moving water, or artificial agencies such as dumping.

**Diatoms:** These are single-celled algae whose cellular contents are enclosed between two valves of silica that are preserved when the organism dies. Often these are preserved in ponds, streams, and important to stream ecology. These are useful in reconstructing aquatic paleoenvironments.

**Eraillure Scar:** A small enigmatic flake formed between the bulb of force and the bulbar scar.

**Erosional Unconformity:** A significant break or gap in the geological or depositional record,

indicative of removal of the older unit prior to renewed deposition.

**Facies:** A definable subdivision of a formal or informal stratigraphic unit.

**Floodplain:** A nearly level alluvial plain that borders a stream or river and is subject to periodic flooding.

**Fossiliferous:** A sedimentary rock that contains fossils.

**Gelatinization:** In regards to starch grains this is a morphological change (distortion of the original shape) in the grain caused by the exposure to heat and water when starches are cooked.

**Geomorphology:** That part of geography concerned with the form and development of the landscape.

**Geophytes:** These are plants with underground storage organ such as bulbs (i.e., onions, camas, and false garlic), tubers, roots, and rhizomes that are a reserve of carbohydrates, nutrients, and water. These storage organs can be collected, cooked, and eaten as part of the human diet. The study of these geophytes from an archeological site aids in determining the diet of the past occupants.

**Glume:** Pertains to small dry membranous chaffy bract found at the base of a grass spikelet or each flower in a sedge or related plant.

**Gorget:** These are usually a polished stone, sometimes of shell or limestone, with holes drilled in it. These are presumably worn as jewelry by natives.

**Graticule:** A device used in the microscope to measure the size of items under magnification.

**Hard/High Silica Polish:** This is a residue that comes from the material that a stone tool came in contact with. This type of polish is generally produced when processing bone, antler, wood, or plants with high silica content such as grasses, reeds, and potentially soil. This polish was detected

during high-powered microscopic use-wear studies conducted during stone tools analysis.

**HCL:** Hydrochloric acid, which is the solution of hydrogen chloride (HCl) in water. It is a highly corrosive, strong mineral acid and has major industrial uses.

**Heating Element:** This is an intentional, intact and localized spot were a human created a fire in an archeological site or component. This is generally evidenced by quantities of wood charcoal, prepared basin, lenses of charcoal or ash, and possibly an oxidation rim often accompanied by intentionally placed rocks, either lining the margins or directly amongst the charcoal. The function of this fire may reflect many different things, such as for heat to warm a person, to cook on, or to heat rocks for other uses. The specific contents may provide clues as to a more specific function or length of use.

**High-powered Microscopic Use-wear:** This is the examination of the artifacts employing microscopes using 100 to 500 power for the presence of residues and wear related to use.

**Hilum:** The scar on a seed, such as a bean, indicating the point of attachment to the funiculus. The nucleus of a starch grain.

**Holocene:** Geological time period spanning roughly the last 10,000 years before present. The Holocene is roughly equivalent to the Postglacial period, and often referred to as the “Recent” period in geology. Many investigations consider the Holocene as an interstadial in the ongoing Pleistocene epoch.

**Horizon:** A discrete, relatively uniform layer in a soil profile that is typically parallel with the surface and formed as the result of pedogenic process. These include A, B and C soil horizons, which are often times subdivided into more specific divisions such as Ab, Bk, etc.

**Humates:** These are substances formed from the biological and chemical breakdown of animal and plant life over time. Humates are made up of

compounds and materials that plant life on earth absolutely needs for growth. Humates contain a mixture of organic acids, including humic acids, fulvic acids, macromolecules of amino acids, amino sugars, and peptides. The chemistry of humate is so complex it cannot really be broken down.

**Humus:** A dark, organic-rich substance consisting of decomposed organic material (animal or vegetable) and is found in the soil.

**Incipient:** Beginning to exist or appear; in an initial stage.

**In situ:** An artifact in its original position that was placed or deposited within the landscape.

**Integrity:** This refers to the degree of intactness of archeological deposits, components, features, or artifacts.

**Inulin:** This is a carbohydrate, a fructan is not digestible via acid hydrolysis, the typical way we digest carbohydrates such as starch.

**Isotope:** An atom of an element. One of two or more forms of a chemical element, differentiated by the number of neutrons contained in the nucleus.

**Jasper:** A dense, cryptocrystalline, opaque to slightly translucent variety of chert associated with iron oxide impurities that give the rock various colors. Most often red, but can be yellow, green, grayish-blue, brown, or black.

**Karastic:** An area of irregular limestone in which erosion has produced fissures, sinkholes, underground streams, and caverns.

**Knapping:** A term used to describe the manufacturing of prehistoric chipped stone tools using different techniques, such as pressure and/or percussion methods, to chip/flake a target mass of material to form a useful tool.

**Lamellae:** This is a thin plate-like structure, often one amongst many lamellae very close to one another, with open space between. Aside from respiratory organs, they appear in other biological roles including filter feeding, the traction surfaces

of geckos, and chloroplast membranes where high permeability is important.

**Legume:** A plant that produces a bean or seedpod in various forms consisting of one cell and/or two valves. Common legume plants across Texas include such plants as; mesquite, Texas ebony, various acacia, retama, *Dalea* sp., mimosa, and rattlebush.

**Lithic:** Means “of stone”. This term is used by archeologists to refer to stone artifacts and the debris derived from the manufacture of stone artifacts.

**Lithology:** The scientific study and description of rocks, especially at the macroscopic level, in terms of their color, texture, and composition. The gross physical character of a rock or rock formation.

**Little Barley:** This is a short winter annual bunch grass with a scientific name of *Hordeum pusillum* in the Poaceae grass family. It has a rapid growth period with a brown seed that develops after spring and is available in the early summer. The seed head consists of flattened spikes. It is considered low in protein and is intolerant to shade. This grass has a low drought tolerance but can grow with only 10 inches of rain per year. It is considered a C<sub>3</sub> grass (-26.7%; Smith and Brown 1973) adapted to fine and medium soil (<http://plants.usda.gov> 2011).

**Loam:** This is soil composed of sand, silt, and clay in relatively even concentration (about 40-20% concentration respectively). Loam soils generally contain more nutrients and humus than sandy soils, have better drainage and infiltration of water and air than silty soils, and are easier to till than clay soils.

**Macrobotanical:** These are remains of plant tissues, such as wood, charcoal, and seeds that one can see with the naked eye. The burning of plant parts implies use prehistorically.

**Maize or Zea Mays:** The scientific name for corn, which is a water-efficient C<sub>4</sub> plant with a shallow root system. The corn cob is also known as a rachis, which have alignments of cupules that are weakly



jointed. The term Indian corn generally refers specifically to multi-colored "field corn" (flint corn) cultivars. There are many forms of maize, such as flint corn, popcorn, Dent corn, sweet corn (modern), and others.

**Mano:** This is a hand-held stone, usually sandstone or quartzite, used to grind plants such as corn, nuts, seeds, or other vegetable matter and sometimes other rocks. It is used in conjunction with a stone metate that plants are placed on to perform the grinding.

**Manuport:** An object, usually a rock, that was transported by humans to the place it was recovered, but its macroscopic appearance does not indicate it had been artificially altered to form a specific tool or other kind of artifact.

**Matrix:** Refers to the sediments in which the artifacts at an archeological site are encased, or surrounds.

**Mesic Condition:** A relatively moist interval of time generally used in the context of climatic conditions.

**Metate:** A slab of rock in which vegetable matter is placed upon for the purpose of grinding. The natural surface becomes polished and a concave depression forms on the metate surface from continued grinding. The grinding stone used with the metate is called a mano.

**Microdebitage:** Any stone or lithic material from the manufacture of stone tools that is less than 4.0 mm in diameter. Microdebitage is often recovered in sieving or floating sediments from archeological deposits.

**Microfossils:** These include a variety of very tiny residues that include such things as starch grains, diatoms, phytoliths, pollen, and organic remains that are only detectable and visible under high-powered microscopes.

**Midden:** This is somewhat of a catch-all term. It generally refers to an accumulation of cultural material such as a zone of burned rocks, and it is

often used to refer to a thick accumulation of mixed cultural material in a vertical zone.

**Migmatite:** This is a rock at the beginning between igneous and metamorphic rocks. These rocks form under extreme temperature conditions during volcanic activity, prograde metamorphism.

**National Historic Preservation Act:** This is the federal law passed in 1966 that establishes a program for the preservation of significant historic properties throughout the United States.

**National Register of Historic Places:** This is the federal list of significant historic properties maintained by the National Parks Service.

**Organic:** Compounds that contain carbon and are associated with living organisms. Materials or objects that contain organic carbon can be radiocarbon dated.

**Overbank Deposits:** The deposition of fine silts and clay particles that are left on terrace tops and banks when water in creeks exceeds the capacity of the channel and drops the suspended sediments in the lower energy environment. Overbank depositional processes usually cause minimal movement to large objects on the terrace top.

**Oxidation:** A chemical process wherein oxygen is added to minerals or other compounds; weathering oxidizes minerals; burning wood and rusting metal are types of oxidation.

**Paleoenvironment:** Ancient or past environments.

**Paleosol:** Generally refers to a soil that developed an A horizon and was subsequently buried by younger deposits.

**Palimpsest:** Archeologically, refers to the inability to distinguish and separate material remains from repeated occupations by a succession of cultural events of different ages due to their deposition and intermixing over time on relatively stable surfaces. Some palimpsest assemblages are buried following a long period of exposure.

**Panicoid:** A group of short cell grass phytoliths derived from tall C<sub>4</sub> grasses and are taxonomically diagnostic of switch grass (*Panicum*), big and little bluestem (*Andropogon* sp.), and Indian grass (*Sorghostrum*). These grasses do well in warm, moist environments and are a major species in the tallgrass prairies. These include basic morphotypes that include simple lobate, panicoid-type, cross, and other lobate forms.

**Ped:** A unit of soil structure such as an aggregate, crumb, prism, block, or granule, formed by natural processes.

**Pedogenesis:** The dynamic process of soil formation and development, which typically leads to the formation of a darkened, organic-rich A horizon at or near the surface, and the downward movement of fine clays into, and/or the formation of carbonate nodules within, the underlying B horizons.

**Pedoturbation:** A general term used to describe soil that has been mixed.

**Pee Dee Belmnite:** A limestone found in Southern Carolina used as the international standard for various compositional (carbon and oxygen isotopic and elemental) analyses.

**Phase:** A group of related archeological traits (e.g., artifacts, features) that contain similar cultural material and date to one relatively narrow time period within a limited region.

**Phytolith:** These are microscopic, inorganic siliceous bodies/residues that form in plant cells and frequent mirror parent cell shape. They are produced in multiple shapes and sizes. After the plant dies, the silica bodies become part of the mineral component of soils. A single plant may produce many different phytolith forms. A single phytolith form may be produced by a number of plant taxa. Phytoliths may survive for thousands of years and provide evidence of past plants.

**Platform:** The specific location where a flake was struck to remove it from the core.

**Pleistocene:** The first epoch, which along with the Holocene Epoch constitutes the Quaternary period, spanning the time between roughly 2.0 or 1.65 million years ago and 10,000 years ago. Characterized by repeated continental glaciations, the Pleistocene witnessed the evolution of modern humans.

**Poaceae:** This, also called Gramineae or true grasses, is a large and nearly ubiquitous family of monocotyledonous flowering plants. There are more than 10,000 domesticated and wild species, the Poaceae represent the fifth-largest plant family. The three Poaceae subfamilies include Poooids, Panicoids, and Chloridoids.

**Poooids:** A group of phytoliths from mostly cool-moist C<sub>3</sub> grasses such as fescue (*Festuca* sp.), Canada wildrye (*Elymus* sp.), Foxtail barley (*Hordeum* sp.), and western wheatgrass (*Agropyron* sp.). These grasses often grow in shaded areas and in riparian environments. Basic morphotypes for Poooids include keeled, conical, pyramidal, and crenate forms.

**Pressure Flaking:** A method used to shape stone tools through the application of force applied by pushing rather than striking. This is generally part of the final stages of finishing a stone tool.

**Profile:** A cross-sectional exposure of the sequence of horizons that make up a soil or a sequence of sedimentary deposits. It can be the result of either natural erosional down cutting or an artificial excavation.

**Provenience:** The specific vertical and horizontal location of where an object is found.

**Quaternary:** The second period, which along with the Tertiary Period, make up the Cenozoic Era, encompassing the Pleistocene and Holocene epochs; roughly the last 2.0 or 1.65 million years.

**Rabdotus:** This is a common land snail found across much of Texas, often in archeological context. These live in a habitat of semiarbooreal, grass and shrubs primarily in central, and south and

west Texas. These hold promise for determining subsistence strategies and recreating of past environments.

**Radiocarbon Dating:** The process of determining the age of a sample based on the amount of radioactive carbon (carbon 14) retained in that object.

**Raphides:** Needle-shaped crystals in a plant cell, typically of calcium oxalate. These are small (30 to 500 µm) crystals, generally with points on the ends and of similar lengths. They are often found in plants of the Agavaceae family such as sotol, yucca, agave, and lechuguilla. They are not diagnostic of any particular plant. Bohrer (1987) and Kwiatkowski (1992) believe that only agave contain these crystals. In contrast, Dering (2003) believes raphides occur in a variety of Agavaceae including sotol, yucca, agave, and beargrass.

**Retouch:** A technique of chipped stone artifact manufacture in which pressure flaking is used to detach small flakes to sharpen or otherwise modify the edge of a stone tool.

**Scarp:** A very steep bank or slope; an escarpment.

**Section 106 Process:** This is the federal process to assess whether or not a project will have effects on historic properties. The basic steps include establishing the parameters of the development/undertaking, identifying the historic properties within the undertaking, if historic properties are affected then assess the effects, and resolve the adverse effects. The assessing is generally done in terms of evaluating/testing, whereas the resolving the adverse effects is through avoidance or data recovery/mitigation.

**Silt:** A particle size that has a range from 0.06 mm to 0.002 mm. These are smaller than sand grains and larger than clay particles.

**Siliceous:** Pertaining to silica, as in silicon dioxide, the most common chemical constituent on earth, and the dominant component of chert and quartz.

**Site Structure:** The spatial distribution of features, artifacts, and debris across a single occupation (or within a component) of an archeological site that is used to reconstruct manufacturing, maintenance, processing, production, and disposal activities at specific loci, and the spatial ways prehistoric groups organized their space at a site.

**Slackwater:** Water that is essentially still/unstressed or with no movement either way.

**Slickensides:** This term is used to describe polished, grooved surfaces that occur along shear planes within the soil. These shear planes result from the shrink-swell action of smectite clays.

**Soft Polish:** This is a residue left on stone tools and comes from the material that a stone tool used on. This type of polish is generally produced when processing animal skins, muscle or soft plants. This polish was detected during high-powered microscopic use-wear studies conducted during stone tools analysis.

**Soil Horizon:** A layer of soil, approximately parallel to the surface, having distinct characteristics produced by soil-forming processes. In the identification of soil horizons an upper case letter (i.e., A, B, C, R, and O) represents the major horizons with A at the top. Lower case letters that follow the upper case letters represent subdivisions of the major horizons.

**Sponge Spicules:** Spicules are structural elements found in most sponges. They provide structural support and deter predators. Large spicules that are visible to the naked eye are referred to as megascleres, while smaller, microscopic ones are termed microscleres. Megascleres are large spicules measuring from 60-2000 µm. Spicules are found in a range of symmetry types. Sponges can be calcareous, siliceous, or composed of organic substance called spongin. The composition, size, and shape of spicules is one of the largest determining factors in sponge taxonomy.

**Sponge Gemmoscleres:** Gemmoscleres are important for sponge species survival. They are part of the sponge's reproductive mechanism. Gemmules--which are spheres with the axially aligned gemmoscleres forming the outer "wall" of the gemmule as a layer or shell protecting the sponge larvae inside--are released from adult sponges to establish new sponge colonies.

**Starch:** Starch is produced by all green plants for energy storage and is a major food source for humans. Pure starch is a white, tasteless and odorless powder that is insoluble in cold water or alcohol. Starch can be used as a thickening, stiffening or gluing agent when dissolved in warm water, giving, for example, wheat paste. In photosynthesis, plants use light energy to produce glucose from carbon dioxide. The glucose is stored mainly in the form of starch granules. Toward the end of the growing season, starch accumulates in twigs of trees near the buds. Fruit, seeds, rhizomes, and tubers store starch to prepare for the next growing season.

**State Antiquities Landmark (SAL):** This is any archeological site on county or municipal property, according to the Antiquities Code of Texas (Texas National Resources Code of 1977, Title 9, Chapter 191 as amended). State Antiquities Landmarks with high research potential may be designated by the Texas Historical Commission.

**Stipa:** Stipa is a genus of around 300 large perennial hermaphroditic grasses (Poaceae) collectively known as feather grass, needle grass, and spear grass. They are placed in the subfamily Pooideae and the tribe Stipeae

**Strath:** These are types of stream terraces that form in tectonically. Straths are planar, erosional surfaces that act as floodplains for bedrock streams, and they form adjacent to stream channels when rates of lateral stream erosion exceed rates of downward stream erosion.

**Stratigraphy:** The study of layering in rocks and/or sediments, and how the layers correlate to each other.

**Striae:** These are tiny, thin, narrow grooves, channels, or lines, often called striations. Here, they were observed during high-powered microscopic use-wear analysis on stone tools and are an indication of the direction of the movement of the tools during their use. They were observed under high magnification in the residues left on the tools.

**Terrace:** In geologic terms this is an old alluvial plain that is generally flat and borders a river, stream, lake, or sea. Terraces are recognized by different elevations and generally labeled T<sub>0</sub>, T<sub>1</sub> and T<sub>2</sub> from lowest to highest.

**Thalweg:** The line defining the lowest points along the length of a river bed or valley.

**Triticeae:** This is a tribe within the Pooideae subfamily of grasses that includes genera with many domesticated species. Major crop genera are found in this tribe including wheat, barley, and rye; crops in other genera include some for human consumption and others used for animal feed or rangeland protection. Seed storage proteins in Triticeae are implicated in various food allergies and intolerances.

**Turbation:** Disturbance to natural matrix deposits generally caused by biological agents (burrowing rodents, insects, worms, and plant roots) and natural (soil creep, desiccation crack displacement, frost heaving, landslides, etc.) processes. These actions tend to move cultural objects in the ground.

**Tuber:** This is the thick, fleshy underground stem of a plant. This stem serves as the primary storage organ of nutrients that stores food over winter and produces new growth in spring.

**Type:** This is a group of similar items (ceramic sherds or projectile points) all of which are more or less the same.

**Ultraviolet (UV) Light:** The wave length of light above that is usually detected by the human eye and that fluorescence various kinds of minerals and emits distinctive colors. Here, a multiband light source (UV light 254/366 nm Model UVGI-58) was used to investigate the visual fluorescence of culturally modified stones to help in identifying their geological source and also detect new/recent scars from old flake scars.

**Unconformity:** Stratigraphic term for a boundary or break created by a depositional hiatus. This boundary separates younger strata from older strata. An unconformity is usually caused by erosion and therefore deposits are missing.

**Use-wear:** The high-powered microscopic evidence on a stone tool that was created from sustained use. The wear may appear as striations, tiny nicks, abrasive particles, polish, rounding, soluble inorganic residues, etc. The accompanying use-wear study used magnification between 100x

and 500x to observe wear and edge-modification on selected artifacts. This detailed analysis contributes to our understanding of the function of tools and potentially substances that tools were used on.

**Wildrye (*Elymus* sp.):** A common grass throughout the Plains of the United States, from Mexico to Canada and is all across Texas. The seeds of this genus are large and it possesses a large distinctive starch grain. This is a cool season C<sub>3</sub> grass (ca. -27.6‰, -27.1‰, Bender 1971) that produces short cell phytoliths. The seeds are available during the summer and fall.

**Xeric Condition:** A dry or relatively arid condition often in reference to climatic conditions.

**Xerophic Plants:** These are plants that have adapted to survive in an environment that lacks water, such as a desert. These include cactus, sotol, yucca, agave, and lechuguilla, and others.

# **APPENDIX A**

## **GEOMORPHOLOGICAL DESCRIPTIONS**

Prepared for:



TRC Environmental Corporation  
505 East Huntland Drive, Suite 250  
Austin, Texas 78752

Prepared by:

Charles D. Frederick, Ph.D.  
2901 Highway 1496  
Dublin, TX 76446

January 2005

*This page intentionally left blank.*

## GEOMORPHOLOGICAL DESCRIPTIONS

Charles D. Frederick, Ph.D.

**Table A-1. Mechanical Trench Descriptions at 41LM49.**

41LM49 Trench 1

Geologic Units: Unit 5b overlying Unit 5a  
 Cultural material: One prehistoric burned rock feature (presumed to of Late Prehistoric age) in Zone 20  
 Comments: Depths are not listed given that not all of the strata could be found in a single vertical column. Refer to Figure 3 for a graphic rendition of the stratigraphy in this trench. The dark color of zones like 12, suggest that this is the natural color of the clay fraction and not evidence of soil development.

Zone	Horizon	Depth(cmbs)	Description
1	Ap	na	Very dark gray (10YR 3/1, moist) slightly gravely sandy loam, very friable, weak medium subangular blocky structure, abrupt clear boundary, 3 to 5% coarse fragments, matrix-supported fine to medium, subrounded, limestone gravel
2	Ap	na	Very dark grayish brown (10YR 3/2, moist) slightly gravely loam, firm, moderate very coarse subangular blocky structure, abrupt smooth boundary, <15% coarse fragments, matrix-supported fine to medium, subrounded, limestone gravel
3	C	na	Dark grayish brown (10YR 4/2, moist) sand, loose, single grained, abrupt discontinuous boundary
4	Ap?	na	Dark grayish brown (10YR 4/2, moist) slightly gravely loam, firm, strong medium subangular blocky structure, abrupt smooth boundary, very dense, possibly disturbed by construction, <15% coarse fragments, matrix-supported fine to medium, subrounded, limestone gravel
5	C	na	Dark grayish brown (10YR 4/2, moist) loamy sand to sand, very friable, weak fine subangular blocky structure, abrupt smooth boundary, 1% calcium carbonate filaments
6	C	na	Light yellowish brown-yellowish brown (10YR 5.5/4, moist) fine sand, very friable, single grained, abrupt smooth boundary, 1 to 3% calcium carbonate filaments, horizontal laminations
7	AC	na	Brown (10YR 4/2, moist) silt loam, very friable, moderate to strong medium subangular blocky structure, abrupt smooth boundary, 5 to 7% calcium carbonate filaments



Zone	Horizon	Depth(cmbs)	Description
8	Ab	na	Very dark gray (10YR 3/1, moist) loam to silt loam, very friable, moderate to strong, medium subangular blocky structure parting to strong very fine subangular blocky structure, abrupt smooth boundary, 5 to 25% calcium carbonate filaments, common to many prominent white calcium carbonate coats on ped faces
9	AC	na	Dark grayish brown (10YR 4/2, moist) loam to sandy loam, very friable, moderate medium subangular blocky structure, abrupt smooth boundary, 7 to 10% calcium carbonate filaments
10	C	na	Brown (10YR 5/3) loamy sand, very friable, single grained, abrupt smooth boundary, 1 to 3% calcium carbonate filaments
11	C	na	Light yellowish brown (10YR 6/4, moist) fine sand, very friable, single grained, abrupt smooth boundary, 1% calcium carbonate filaments, horizontally laminated
12	AC	na	Dark brown (10YR 3/3, moist) sandy loam, very friable, weak fine subangular blocky structure, abrupt smooth boundary, 5 to 7% calcium carbonate filaments
13	C	na	Yellowish brown (10YR 5/4, moist) fine sand, very friable, single grained, abrupt smooth boundary, 3 to 5% calcium carbonate filaments, horizontally laminated in places
14	AC	na	Very dark grayish brown-dark grayish brown (10YR 3.5/2, moist) sandy loam, very friable, weak fine subangular blocky structure, abrupt smooth boundary, 15 to 20% calcium carbonate filaments
15	C	na	Brown (10YR 4/3, moist) loamy sand, very friable, weak fine subangular blocky structure to single grained, abrupt smooth boundary, 10 to 15% calcium carbonate filaments
16	AC	na	Very dark gray (10YR 3/1, moist) sandy loam, very friable, weak fine subangular blocky structure, abrupt smooth boundary, 5% calcium carbonate filaments, probably a dark fine-grained deposit and not a soil
17	C	na	Brown-yellowish brown (10YR 5/4 to 10YR 5/3, moist) loamy sand to sand, loose to very friable, single grained, abrupt smooth boundary, horizontal laminations preserved in places, few bits of charcoal throughout
18	AC	na	Dark grayish brown (10YR 4/2, moist) sandy loam, very friable, massive, abrupt smooth boundary, 1% calcium carbonate filaments
19	C	na	Dark grayish brown (10YR 4/2, moist) very gravely sandy loam, very friable to loose, abrupt smooth boundary, 1 to 3% calcium carbonate filaments, 60 to 90% coarse fragments, fine to medium, clast-supported subrounded limestone (90%) subrounded sandstone (5%) and subangular chert (5%) gravel

<b>Zone</b>	<b>Horizon</b>	<b>Depth(cmbs)</b>	<b>Description</b>
20	Ab?	na	Very dark brown (10YR 3/2, moist) slightly gravely sandy loam, friable, moderate medium subangular blocky structure, abrupt smooth boundary, 3 to 5% calcium carbonate filaments, 3 to 10% coarse fragments of fine subrounded matrix-supported limestone gravel
21	Ab?	na	Black (10YR 2/1, moist) gravely sandy loam, loose, weak medium subangular blocky structure to single grained, abrupt smooth boundary, 15 to 35% coarse fragments, fine to medium, clast-supported, rounded limestone (95%) subrounded discoidal shale (2%), subangular chert (3%) and subrounded sandstone (1%)
22	Ab?	na	Very dark grayish brown (10YR 3/2, moist) gravely sandy loam, loose to very friable, abrupt smooth boundary, 15 to 35% coarse fragments, fine to medium, clast-supported subrounded limestone (90%), rounded sandstone (5%), and subangular chert (5%)
23	C	na	Dark yellowish brown (10YR 4/4, moist) loamy sand to sandy gravel, loose to very friable, abrupt wavy boundary, 15 to 35% coarse fragments, fine to medium, clast-supported subrounded limestone (90%), rounded sandstone (5%), and subangular chert (5%)
24	Ab?	na	Very dark gray-very dark grayish brown (10YR 3/1.5, moist) loam, very friable, weak medium subangular blocky structure, abrupt smooth boundary, 1% calcium carbonate filaments
25	CA	na	Dark yellowish brown (10YR 4/4, moist) sandy loam, very friable to loose, single grained, abrupt smooth boundary, trace of gravel (<1%)
26	Ab?	na	Dark yellowish brown (10YR 4/4, moist) loam, very friable, weak coarse subangular blocky structure, 3% calcium carbonate filaments

## 41LM49 Trench 2

Geologic Units: Unit 4  
 Cultural material: None observed  
 Comments: None

Zone	Horizon	Depth(cmbs)	Description
1	Ap	0-14	Brown (10YR 4/3, moist) loam, very friable, weak moderate subangular blocky structure, abrupt smooth boundary; 30 to 40% bioclasts (faint to distinct, coarse, cylindrical, sharp-edged worm casts), this deposit appears to be high related construction fill
2	A	14-23	Black (10YR 2/1, moist) loam, friable, moderate medium to fine subangular blocky structure, abrupt smooth boundary
3	A	23-44	Very dark gray to black (10YR 3/1 to 10YR 2/1, moist) sandy loam, friable, moderate to strong, medium subangular blocky structure, gradual smooth boundary
4	A	44-79	Very dark grayish brown (10YR 3/2, moist) slightly gravely sandy loam, weak coarse subangular blocky structure, abrupt smooth boundary, 5 to 7% calcium carbonate filaments, <15% coarse fragments, primarily matrix-supported subrounded limestone in a discontinuous stringer scattered throughout the base of the zone
5	Bk	79-108	Brown (10YR 4/3, moist) sandy loam, very friable, weak, medium to coarse subangular blocky structure, abrupt smooth boundary, 5 to 7% calcium carbonate filaments
6	Bk	108-117	Brown (10YR 4/3, moist) gravely to slightly gravely loam, loose, single grained, abrupt smooth boundary, 10 to 35% coarse fragments, mostly fine to medium subrounded limestone, imbricated in places, common, prominent, thin (<1mm) calcium carbonate pendant cements on bottoms of gravel clasts
7	C	117-140	Brown (10YR 4/3, moist) sandy loam, very friable, massive, abrupt smooth boundary, 1 to 3% calcium carbonate filaments
8	Bk	140-190	White (10YR 8/1, moist) very gravely sand, loose, single grained, abrupt smooth boundary, 60 to 90% coarse fragments, primarily medium subrounded limestone (85%), rounded sandstone (10%) and subangular chert (5%), with occasional large (up to 45 cm long) tabular stones of limestone
9	C	190-195	Dark yellowish brown (10YR 4/4, moist) sand, loose, single grained, abrupt smooth boundary
10	C	195-200	Dark yellowish brown (10YR 4/4, moist) loamy sand, very friable, single grained, abrupt smooth boundary
11	C	200-240	Dark yellowish brown (10YR 4/4, moist) sand, loose to very friable, single grained, few, thin, fine gravel stringers

**Table A-2. Mechanical Trench Descriptions at 41LM50.**

41LM50 Trench 1

Geologic Units: Presumed to be an early-middle Holocene age alluvial deposit  
 Cultural material: Possibly 3 occupations: an obvious one around 10 cm, trace of one around 25 cm, and another clear one at 60 to 70 cm.  
 Comments: This soil appears to have clear vertic tendencies. Top 80 cm or so appears to be cumulic.

Zone	Horizon	Depth (cmbs)	Description
1	Ap	0-12	Black (10YR 2/1, moist) silty clay to clay, friable to firm, moderate to strong coarse subangular blocky structure, clear smooth boundary
2	A	12-70	Black (10YR 2/1, moist) clay, extremely firm, strong medium to fine subangular blocky structure, clear smooth boundary, common distinct discontinuous pressure faces on ped faces
3	ABkss	70-90	Very dark gray (10YR 3/1, moist) clay, firm, strong medium angular blocky structure parting to strong medium wedge structure, clear smooth boundary, few (1%) calcium carbonate filaments, few (ca. 25%) distinct discontinuous pressure faces on ped faces, few (ca. 10%) distinct discontinuous slickensides on ped faces
4	Bkss	90-130	Very dark gray (10YR 3/1, moist) clay, extremely firm, strong coarse to medium angular blocky structure, gradual smooth boundary, few (3%) calcium carbonate filaments, few (<2%) medium (2 to 5 mm) distinct cylindrical sharp-edged, vertically oriented white (10YR 8/1) calcium carbonate nodules, few (ca. 20%) distinct discontinuous pressure faces on ped faces, few (ca. 5%) distinct discontinuous slickensides on ped faces, common 1 to 3 cm wide crack fills with darker (10YR 3/1) clay fill, decrease in frequency with depth
5	Bk1	130-220	Brown-dark brown (10YR 3.5/2.5, moist) clay, extremely firm, strong coarse to medium angular blocky structure, clear smooth boundary, few (1 to 3%) calcium carbonate filaments, common (5 to 7%) coarse (1 to 3 cm) prominent irregular (hollow popcorn-shaped) grayish brown (10YR 5/2) sharp-edged calcium carbonate nodules
6	Bk2	220-240	Brown (10YR 4/3, moist) clay, firm, strong medium angular blocky structure, many (>50%) calcium carbonate filaments, common (5 to 7%) coarse (1 to 3 cm) prominent irregular (hollow popcorn-shaped) grayish brown (10YR 5/2) sharp-edged calcium carbonate nodules

41LM50 Trench 2

Geologic Units: Presumed to be an early-middle Holocene age alluvial deposit  
 Cultural material: Possibly 3 occupations: an obvious one around 10 cm, a second around 25 cm, and a third at 60 to 70 cm  
 Comments: None

Zone	Horizon	Depth(cmbs)	Description
1	A	0-60	Black (10YR 2/1 to N 2/0, moist) clay, very friable to firm, strong fine to medium subangular blocky structure, gradual smooth boundary, few faint pressure faces on ped faces
2	AB	60-80	Very dark grayish brown (10YR 3/2, moist) clay, very firm to firm, strong medium angular blocky structure parting to strong medium wedge structure, gradual smooth boundary, common distinct discontinuous pressure faces on ped faces, trace of slickensides on ped faces
3	Bk1	80-130	Dark yellowish brown (10YR 3/4, moist) clay, firm, strong medium angular blocky structure, gradual smooth boundary, few (1%) calcium carbonate filaments, common (5%) medium to coarse (0.5 to 1.5 mm) distinct irregular sharp-edged, (hollow popcorn-shaped) grayish brown (10YR 5/2) calcium carbonate nodules, few (ca. 20%) faint discontinuous pressure faces on ped faces, common 1 to 3 cm wide crack fills with darker (10YR 3/1) clay fill, decrease in frequency with depth
4	Bk2	130-235	Dark brown (10YR 3/3, moist) clay, extremely firm, strong medium to coarse angular blocky structure, clear smooth boundary, few (1 to 3%) calcium carbonate filaments, common (5 to 7%) coarse (1 to 3 cm) distinct irregular (hollow popcorn-shaped) grayish brown (10YR 5/2) sharp-edged calcium carbonate nodules few (ca. 20%) distinct discontinuous pressure faces on ped faces
5	Bk3	235-260	Brown (10YR 4/4, moist) clay, firm, strong medium angular blocky structure, many (>25%) calcium carbonate filaments/coats on ped faces, common (2 to 10%) coarse (1 to 3 cm) distinct irregular (hollow popcorn-shaped) grayish brown (10YR 5/2) sharp-edged calcium carbonate nodules

**Table A-3. Mechanical Trench and Unit Descriptions at 41LM51.**

41LM51 Trench 1

Geologic Units: Unit 2  
 Cultural material: Only observed at top of exposure  
 Comments: Pleistocene terrace fill, with a significant groundwater carbonate component

Zone	Horizon	Depth(cmbs)	Description
1	O	0-4	Very dark brown (10YR 2/1, moist) decomposed leaf litter, loose, single grained, abrupt smooth boundary
2	A	4-12	Black (10YR 2/1, moist) loamy sand, very friable, moderate medium to fine subangular blocky structure, clear smooth boundary, some cultural material at the base of the zone
3	AB	12-31	Yellowish brown (10YR 5/4, moist) loamy sand, very friable, weak to moderate medium subangular blocky structure, clear smooth boundary, many prominent very dark grayish brown (10YR 3/2) worm channels/bioclasts throughout
4	Bk	31-101	Yellowish brown (10YR 5/5, moist) loamy sand, very friable, weak coarse subangular blocky structure, diffuse smooth boundary, few (3 to 5%) calcium carbonate filaments, common coarse to very coarse prominent white, sharp-edged, very friable masses to rigid irregular (popcorn-shaped, hollow) nodules of calcium carbonate
5	Bk	101-160	Light yellowish brown (10YR 6/4, moist) sandy loam, very friable, moderate medium to coarse subangular blocky structure, clear smooth boundary, few (3%) calcium carbonate filaments, common medium to coarse prominent white (10YR 8/1) very friable cylindrical to irregular shaped calcium carbonate masses
6	Bk	160-170	Light brownish yellow – brownish yellow (10YR 6/5, moist) loamy sand, very friable, moderate medium subangular blocky structure, clear smooth boundary, 5% calcium carbonate filaments in ped interiors, very few to few faint to distinct patchy calcium carbonate coats on ped faces, common many, medium to coarse prominent white (10YR 8/1) very friable irregular shaped masses to occasional rigid nodules of calcium carbonate; ground water carbonate? forms a distinct horizontal line
7	Bk	170-200	Yellowish brown (10YR 5/4, moist) sandy loam, very friable, moderate medium subangular blocky structure, clear smooth boundary, 5 to 10% calcium carbonate filaments in ped interiors, few to common distinct discontinuous calcium carbonate coats on ped faces channels and pores, common many, medium to coarse prominent white (10YR 8/1) very friable irregular to sub-horizontally oriented cylindrical shaped masses and occasional rigid nodules of calcium carbonate; ground water carbonate (?) few aquatic snails

*Appendix A: Geomorphological Descriptions*

<b>Zone</b>	<b>Horizon</b>	<b>Depth (cmbs)</b>	<b>Description</b>
8	Bk	200-231	Yellowish brown (10YR 5/4, moist) sandy loam, very friable, weak medium subangular blocky structure, abrupt smooth boundary, common distinct medium to coarse very friable white (10YR 8/2) clear edged cylindrically shaped vertically oriented calcium carbonate masses, few medium to coarse rigid distinct white (10YR 8/2) irregular shaped (popcorn-like hollow) calcium carbonate nodules
9	Ck	231-238	Brown (10YR 5/3, moist) very gravelly loamy sand, very friable to loose, single grained, abrupt smooth boundary, common distinct white (10YR 8/1) sharp, 1 to 2 mm thick pendants and threads around rock bottom of gravel clasts, 35 to 60% coarse fragments, medium gravel primarily (ca. 80%) limestone, with minor amounts of shale (5%), sandstone (5%) and chert (10%)
10	Abk	238-268	Grayish brown (10YR 5/2, moist) sandy loam, very friable, weak coarse subangular blocky structure, clear smooth boundary, 3 to 5% calcium carbonate filaments, few snails, few medium distinct strong brown (7.5YR 4/6) mottles, few coarse faint irregular shaped white semi-rigid clear edged calcium carbonate nodules. Possibly a weak A horizon
11	C	268-300+	Brown (10YR 5/3, moist) loamy sand, very friable, weak coarse subangular blocky structure, common to many medium to very coarse yellowish brown (10YR 5/8) mottles, few faint hypocasts of calcium carbonate lining pores

41LM51 Cutbank

Geologic Units: Unit 5b  
 Cultural material: Only recent items, plastic and glass observed.  
 Comments: These are effectively modern floodplain deposits.

Zone	Horizon	Depth(cmbs)	Description
1	Ap	0-15	Dark gray (10YR 4/1, moist) slightly gravely sandy loam, loose, strong very fine crumb structure, abrupt wavy boundary, many worm casts (excrement pedofeatures), few fine rounded limestone gravels
2	C	15-52	Brown (10YR 4/3, dry) loamy sand, slightly hard, massive to weak very coarse subangular blocky structure, abrupt smooth boundary
3	C	52-68	Dark grayish brown (10YR 4/2, dry) loamy sand, slightly hard, weak fine subangular blocky structure, abrupt smooth boundary
4	AC	68-86	Dark gray–very dark gray (10YR 3.5/1, dry) sandy loam, slightly hard, moderate medium subangular blocky structure, abrupt smooth boundary
5	AC	86-141	Very dark grayish brown (10YR 3/2, dry) loam-silt loam, slightly hard, weak to moderate fine subangular blocky structure, abrupt smooth boundary, few (1 to 5%) calcium carbonate filaments, traces of thin bedding visible in places
6	C	141-151	Light yellowish brown (10YR 6/4, moist) sandy loam, very friable, massive, abrupt smooth boundary
7	C	151-174	Dark grayish brown (10YR 4/2, moist) loam, very friable, massive, abrupt smooth boundary
8	C	174-182	Light yellowish brown (10YR 6/4, moist) sandy loam, very friable to loose, massive, abrupt smooth boundary
9	AC	182-194	Dark grayish brown (10YR 4/2, moist) loam, very friable, weak medium subangular blocky structure to massive, abrupt smooth boundary
10	C	194-203	Light yellowish brown (10YR 6/4, moist) gravely sandy loam, very friable to loose, single grain, abrupt smooth boundary, 15 to 35% coarse fragments of fine rounded limestone gravel
11	AC	203-208	Very dark grayish brown (10YR 3/2, moist) loam, very friable, massive, abrupt smooth boundary
12	C	208-216	Brown (10YR 4/3, moist) slightly gravely sandy loam, loose, single grained, abrupt smooth boundary, <15% coarse fragments of fine to medium limestone gravel with minor amounts of sandstone, shale and chert, graded bedding present
13	AC	216-226	Dark gray–very dark gray (10YR 3.5/1, moist) loam, very friable, massive, abrupt smooth boundary
14	C	226-234	Dark grayish brown-very dark grayish brown (10YR 3.5/2, moist) slightly gravely sand, loose, single grained, <15% coarse fragments of fine to medium limestone gravel with minor amounts of sandstone, shale and chert, bedding



41LM51 Test Unit 2, West Wall

Geologic Units: Zone 1 is probably Unit 5b or 5c, whereas Zones 2 and 3 are probably Unit 5a. Zones 4 and 5 appear to be colluvium derived from Unit 2, and Zones 6, 7 and 8 are interpreted as Unit 2.

Cultural material: See test unit data

Comments: None

Zone	Horizon	Depth (cmbs)	Description
1	AC	0-14	Dark grayish brown (10YR 4/2, dry) sandy loam, hard, moderate medium to fine subangular blocky structure, clear smooth boundary
2	2Ab	14-36	Very dark grayish brown (10YR 3/2, dry) sandy loam, slightly hard to hard, moderate clear subangular blocky structure, gradual smooth boundary
3	2C	36-60	Brown (10YR 5/3, dry) loamy sand, slightly hard, massive, clear smooth boundary, 1% calcium carbonate filaments
4	3Bk	60-87	Brown (10YR 5/3, dry) sandy loam, hard, strong coarse subangular blocky structure, gradual smooth boundary, 5 to 7% calcium carbonate filaments within peds, few to common distinct white carbonate coats on ped faces, common medium to coarse prominent irregular to spherical sharp-edged reworked calcium carbonate nodules
5	3Bk	87-110	Brown-pale brown (10YR 5.5/3, moist) loam, very friable, weak medium subangular blocky structure, abrupt smooth boundary, 1 to 3% calcium carbonate nodules, common medium prominent irregular to spherical shaped sharp-edged calcium carbonate nodules, some of which are fragments and not complete
6	4Bk	110-140	Brown-pale brown (10YR 5.5/3, moist) loam-silt loam, very friable, weak medium subangular blocky structure, abrupt smooth boundary, common medium to coarse prominent cylindrical-dendritic and irregular (popcorn-shaped, hollow) sharp to clear edged white calcium carbonate nodules. This zone has more apparently complete and <i>in situ</i> carbonate forms than the overlying two zones, hence this was interpreted as an <i>in situ</i> Unit 2
7	4Bk	140-170	Brown (10YR 5/3, dry) sand, very friable, single grained, abrupt smooth boundary, 1 to 3% calcium carbonate filaments, common coarse faint yellowish brown (10YR 5/8) irregular shaped mottles
8	4C	170-180	Brown (10YR 5/3, dry) slightly gravelly sand, loose to extremely hard, single grained, locally indurated with calcium carbonate, <15% coarse fragments composed of medium subrounded limestone gravel

41LM51 Test Unit 5

Geologic Units:           Holocene alluvium on top of Unit 2, T2 surface  
 Cultural material:       Burned rock with basal elevations at 26 and 45 cm  
 Comments:               None

Zone	Horizon	Depth (cmbs)	Description
1	A	0-17	Very dark grayish brown (10YR 3/2, moist) loam, friable, moderate medium subangular blocky structure, clear smooth boundary
2	AB	17-36	Brown (10YR 4/3, moist) loam, friable, moderate medium to fine subangular blocky structure, clear smooth boundary, few burned rocks around 26 cm
3	Bk1	36-54	Yellowish brown (10YR 5/4, dry) sandy loam, slightly hard, weak medium subangular blocky structure, clear smooth boundary, 1 to 3% calcium carbonate filaments, several burned rocks around 45 cm depth
4	Bk2	54-70	Light yellowish brown (10YR 6/4, dry) loamy sand to sandy loam, hard, moderate medium subangular blocky structure, 7 to 10% calcium carbonate filaments

*This page intentionally left blank.*

# **APPENDIX B**

## **RADIOCARBON ASSAY RESULTS**

Prepared for:



TRC Environmental Corporation  
505 East Huntland Drive, Suite 250  
Austin, Texas 78752

Prepared by:

Alexander Cherkinsky, Ph.D.  
The University of Georgia  
Center for Applied Isotope Studies  
120 Riverbend Road  
Athens, Georgia 30602-4720

and

Darden Hood  
Beta Analytic Inc.  
4985 S.W. 74 Court  
Maimi, Florida 33155

2013

*This page intentionally left blank.*

## RADIO CARBON ASSAY RESULTS



Consistent Accuracy . . .  
. . . Delivered On-time

Beta Analytic Inc.  
4985 SW 74 Court  
Miami, Florida 33155 USA  
Tel: 305 667 5167  
Fax: 305 663 0964  
Beta@radiocarbon.com  
www.radiocarbon.com

Darden Hood  
President

Ronald Hatfield  
Christopher Patrick  
Deputy Directors

March 28, 2013

Dr. James Abbott  
Texas Department of Transportation  
Cultural Resource Management  
Environmental Affairs Division  
125 East 11th Street  
Austin, TX 78701  
USA

RE: Radiocarbon Dating Results For Samples LM49 BR1-3-1, LM49 BR1-3-8, LM50 67-7, LM50 66-7-1, LM50 BR68-3-2, LM50 BR69-3-1a, LM51 4-7

Dear Dr. Abbott:

Enclosed are the radiocarbon dating results for seven samples recently sent to us. They each provided plenty of carbon for accurate measurements and all the analyses proceeded normally. As usual, the method of analysis is listed on the report with the results and calibration data is provided where applicable.

The web directory containing the table of results and PDF download also contains pictures including, most importantly the portion actually analyzed. These can be saved by opening them and right clicking. Also a cvs spreadsheet download option is available and a quality assurance report is posted for each set of results. This report contains expected vs measured values for 3-5 working standards analyzed simultaneously with your samples.

All results reported are accredited to ISO-17025 standards and all analyses were performed entirely here in our laboratories. Since Beta is not a teaching laboratory, only graduates trained in accordance with the strict protocols of the ISO-17025 program participated in the analyses. When interpreting the results, please consider any communications you may have had with us regarding the samples.

If you have specific questions about the analyses, please contact us. Your inquiries are always welcome.

Our invoice will be emailed separately. Please, forward it to the appropriate officer or send VISA charge authorization. Thank you. As always, if you have any questions or would like to discuss the results, don't hesitate to contact me.

Sincerely,

Digital signature on file

	<p><b>BETA ANALYTIC INC.</b> DR. M.A. TAMERS and MR. D.G. HOOD</p>	<p>4985 S.W. 74 COURT MIAMI, FLORIDA, USA 33155 PH: 305-667-5167 FAX: 305-663-0964 beta@radiocarbon.com</p>
---	--	---

## REPORT OF RADIOCARBON DATING ANALYSES

Dr. James Abbott

Report Date: 3/28/2013

Texas Department of Transportation

Material Received: 3/22/2013

Sample Data	Measured Radiocarbon Age	13C/12C Ratio	Conventional Radiocarbon Age(*)
Beta - 345272 SAMPLE : LM49 BR1-3-1 ANALYSIS : AMS-Standard delivery MATERIAL/PRETREATMENT : (organic material): acid washes 2 SIGMA CALIBRATION : Cal BC 840 to 800 (Cal BP 2790 to 2740)	2620 +/- 30 BP	-22.8 o/oo	2660 +/- 30 BP
Beta - 345273 SAMPLE : LM49 BR1-3-8 ANALYSIS : AMS-Standard delivery MATERIAL/PRETREATMENT : (organic material): acid washes 2 SIGMA CALIBRATION : Cal AD 420 to 560 (Cal BP 1530 to 1390)	1530 +/- 30 BP	-22.4 o/oo	1570 +/- 30 BP
Beta - 345274 SAMPLE : LM50 67-7 ANALYSIS : AMS-Standard delivery MATERIAL/PRETREATMENT : (charred material): acid/alkali/acid 2 SIGMA CALIBRATION : Cal AD 1020 to 1160 (Cal BP 930 to 790)	940 +/- 30 BP	-24.4 o/oo	950 +/- 30 BP
Beta - 345275 SAMPLE : LM50 66-7-1 ANALYSIS : AMS-Standard delivery MATERIAL/PRETREATMENT : (charred material): acid/alkali/acid 2 SIGMA CALIBRATION : Cal AD 1020 to 1170 (Cal BP 930 to 780)	930 +/- 30 BP	-25.0 o/oo	930 +/- 30 BP

Dates are reported as RCYBP (radiocarbon years before present, "present" = AD 1950). By international convention, the modern reference standard was 95% the 14C activity of the National Institute of Standards and Technology (NIST) Oxalic Acid (SRM 4990C) and calculated using the Libby 14C half-life (5568 years). Quoted errors represent 1 relative standard deviation statistics (68% probability) counting errors based on the combined measurements of the sample, background, and modern reference standards. Measured 13C/12C ratios (delta 13C) were calculated relative to the PDB-1 standard.

The Conventional Radiocarbon Age represents the Measured Radiocarbon Age corrected for isotopic fractionation, calculated using the delta 13C. On rare occasion where the Conventional Radiocarbon Age was calculated using an assumed delta 13C, the ratio and the Conventional Radiocarbon Age will be followed by "\*\*". The Conventional Radiocarbon Age is not calendar calibrated. When available, the Calendar Calibrated result is calculated from the Conventional Radiocarbon Age and is listed as the "Two Sigma Calibrated Result" for each sample.





## CALIBRATION OF RADIOCARBON AGE TO CALENDAR YEARS

(Variables: C13/C12=-22.8:lab. mult=1)

Laboratory number: Beta-345272

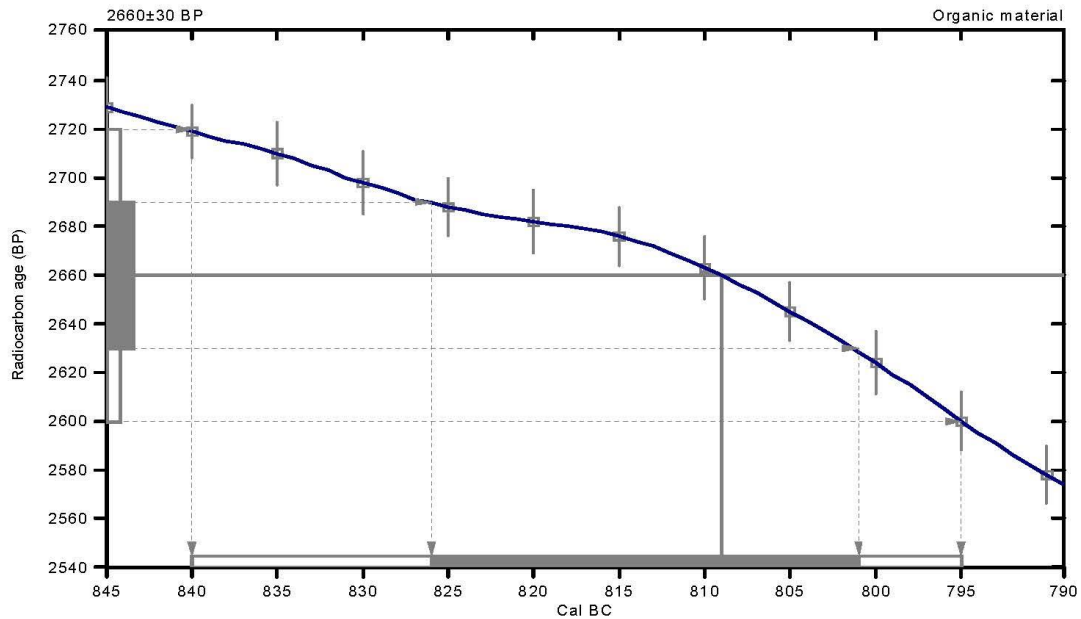
Conventional radiocarbon age: 2660±30 BP

2 Sigma calibrated result: Cal BC 840 to 800 (Cal BP 2790 to 2740)  
(95% probability)

Intercept data

Intercept of radiocarbon age  
with calibration curve: Cal BC 810 (Cal BP 2760)

1 Sigma calibrated result: Cal BC 830 to 800 (Cal BP 2780 to 2750)  
(68% probability)



### References:

#### Database used

INTCAL09

#### References to INTCAL09 database

Heaton, et al., 2009, *Radiocarbon* 51(4):1151-1164, Reimer, et al., 2009, *Radiocarbon* 51(4):1111-1150,  
Stuiver, et al., 1993, *Radiocarbon* 35(1):137-189, Oeschger, et al., 1975, *Tellus* 27:168-192

#### Mathematics used for calibration scenario

A Simplified Approach to Calibrating C14 Dates  
Talma, A. S., Vogel, J. C., 1993, *Radiocarbon* 35(2):317-322

## Beta Analytic Radiocarbon Dating Laboratory

4985 S.W. 74th Court, Miami, Florida 33155 • Tel: (305)667-5167 • Fax: (305)663-0964 • E-Mail: beta@radiocarbon.com

## CALIBRATION OF RADIOCARBON AGE TO CALENDAR YEARS

(Variables: C13/C12=-22.4:lab. mult=1)

Laboratory number: Beta-345273

Conventional radiocarbon age: 1570±30 BP

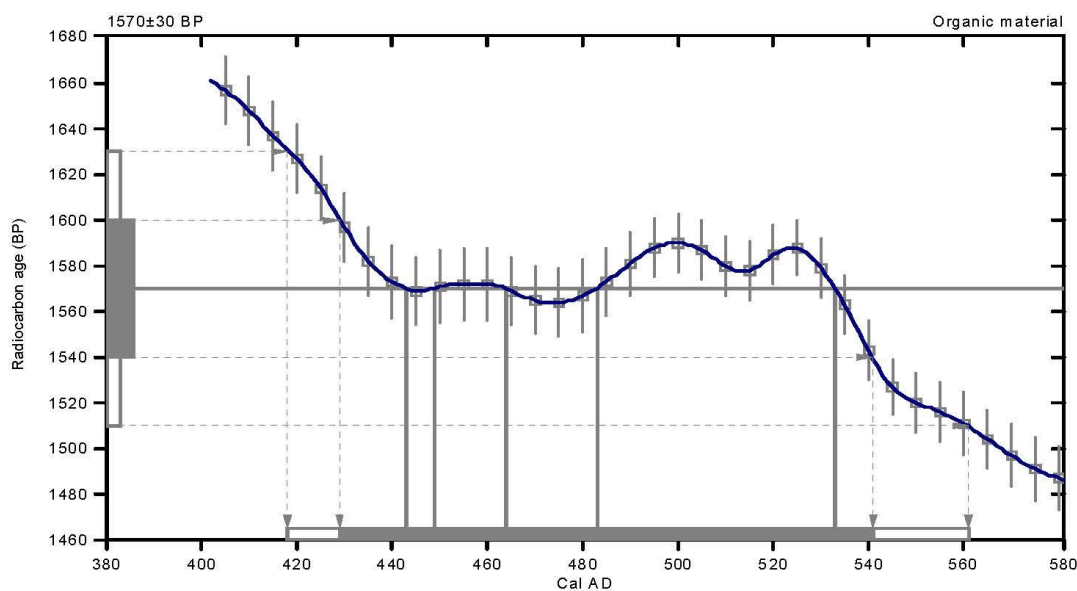
2 Sigma calibrated result: Cal AD 420 to 560 (Cal BP 1530 to 1390)  
(95% probability)

Intercept data

Intercepts of radiocarbon age  
with calibration curve:

Cal AD 440 (Cal BP 1510) and  
Cal AD 450 (Cal BP 1500) and  
Cal AD 460 (Cal BP 1490) and  
Cal AD 480 (Cal BP 1470) and  
Cal AD 530 (Cal BP 1420)

1 Sigma calibrated result: Cal AD 430 to 540 (Cal BP 1520 to 1410)  
(68% probability)



### References:

#### Database used

INTCAL09

#### References to INTCAL09 database

Heaton, et al., 2009, *Radiocarbon* 51(4):1151-1164, Reimer, et al., 2009, *Radiocarbon* 51(4):1111-1150,  
Stuiver, et al., 1993, *Radiocarbon* 35(1):137-189, Oeschger, et al., 1975, *Tellus* 27:168-192

#### Mathematics used for calibration scenario

A Simplified Approach to Calibrating C14 Dates

Talma, A. S., Vogel, J. C., 1993, *Radiocarbon* 35(2):317-322

## Beta Analytic Radiocarbon Dating Laboratory

4985 S.W. 74th Court, Miami, Florida 33155 • Tel: (305)667-5167 • Fax: (305)663-0964 • E-Mail: beta@radiocarbon.com

## CALIBRATION OF RADIOCARBON AGE TO CALENDAR YEARS

(Variables: C13/C12=-24.4:lab. mult=1)

Laboratory number: Beta-345274

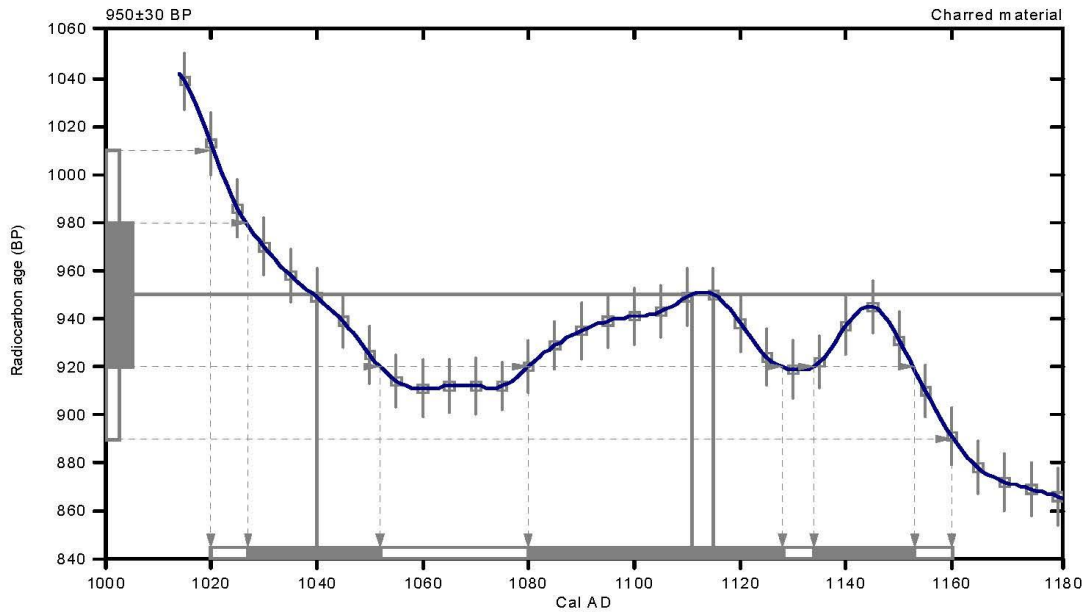
Conventional radiocarbon age: 950±30 BP

2 Sigma calibrated result: Cal AD 1020 to 1160 (Cal BP 930 to 790)  
(95% probability)

Intercept data

Intercepts of radiocarbon age  
with calibration curve: Cal AD 1040 (Cal BP 910) and  
Cal AD 1110 (Cal BP 840) and  
Cal AD 1120 (Cal BP 840)

1 Sigma calibrated results: Cal AD 1030 to 1050 (Cal BP 920 to 900) and  
(68% probability) Cal AD 1080 to 1130 (Cal BP 870 to 820) and  
Cal AD 1130 to 1150 (Cal BP 820 to 800)



References:

*Database used*

*INTCAL09*

*References to INTCAL09 database*

*Heaton, et al., 2009, Radiocarbon 51(4):1151-1164, Reimer, et al., 2009, Radiocarbon 51(4):1111-1150,*

*Stuiver, et al., 1993, Radiocarbon 35(1):137-189, Oeschger, et al., 1975, Tellus 27:168-192*

*Mathematics used for calibration scenario*

*A Simplified Approach to Calibrating C14 Dates*

*Talma, A. S., Vogel, J. C., 1993, Radiocarbon 35(2):317-322*

**Beta Analytic Radiocarbon Dating Laboratory**

4985 S.W. 74th Court, Miami, Florida 33155 • Tel: (305)667-5167 • Fax: (305)663-0964 • E-Mail: beta@radiocarbon.com

## CALIBRATION OF RADIOCARBON AGE TO CALENDAR YEARS

(Variables: C13/C12=-25:lab. mult=1)

Laboratory number: Beta-345275

Conventional radiocarbon age: 930±30 BP

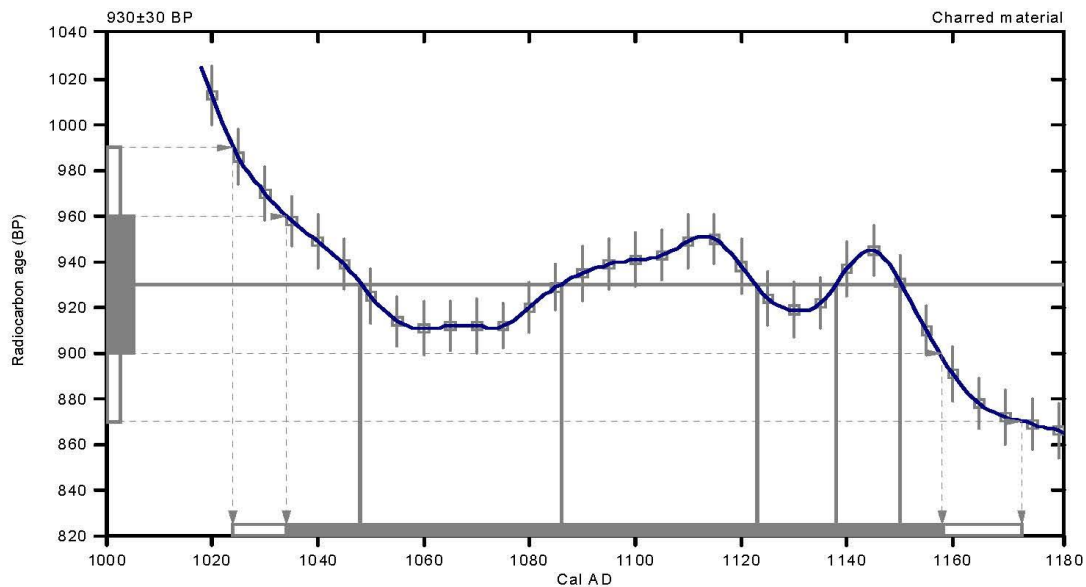
2 Sigma calibrated result: Cal AD 1020 to 1170 (Cal BP 930 to 780)  
(95% probability)

Intercept data

Intercepts of radiocarbon age  
with calibration curve:

Cal AD 1050 (Cal BP 900) and  
Cal AD 1090 (Cal BP 860) and  
Cal AD 1120 (Cal BP 830) and  
Cal AD 1140 (Cal BP 810) and  
Cal AD 1150 (Cal BP 800)

1 Sigma calibrated result: Cal AD 1030 to 1160 (Cal BP 920 to 790)  
(68% probability)



### References:

#### Database used

INTCAL09

#### References to INTCAL09 database

Heaton, et al., 2009, *Radiocarbon* 51(4):1151-1164, Reimer, et al., 2009, *Radiocarbon* 51(4):1111-1150,  
Stuiver, et al., 1993, *Radiocarbon* 35(1):137-189, Oeschger, et al., 1975, *Tellus* 27:168-192

#### Mathematics used for calibration scenario

A Simplified Approach to Calibrating C14 Dates

Talma, A. S., Vogel, J. C., 1993, *Radiocarbon* 35(2):317-322

## Beta Analytic Radiocarbon Dating Laboratory

4985 S.W. 74th Court, Miami, Florida 33155 • Tel: (305)667-5167 • Fax: (305)663-0964 • E-Mail: beta@radiocarbon.com

## CALIBRATION OF RADIOCARBON AGE TO CALENDAR YEARS

(Variables: C13/C12=-23:lab. mult=1)

Laboratory number: Beta-345276

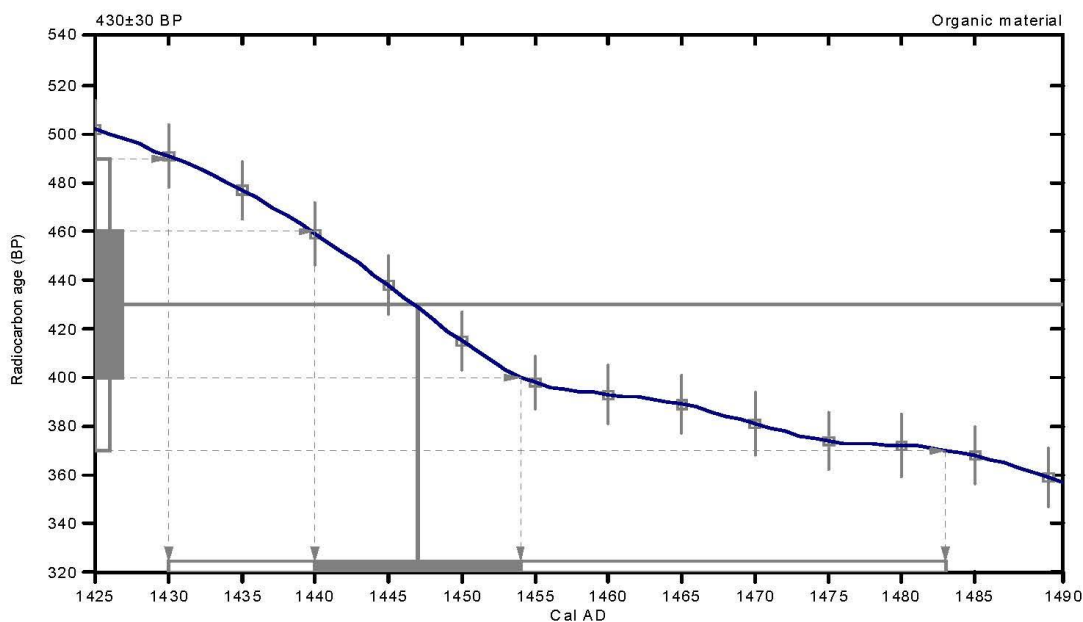
Conventional radiocarbon age: 430±30 BP

2 Sigma calibrated result: Cal AD 1430 to 1480 (Cal BP 520 to 470)  
(95% probability)

Intercept data

Intercept of radiocarbon age  
with calibration curve: Cal AD 1450 (Cal BP 500)

1 Sigma calibrated result: Cal AD 1440 to 1450 (Cal BP 510 to 500)  
(68% probability)



### References:

#### Database used

INTCAL09

#### References to INTCAL09 database

Heaton, et al., 2009, *Radiocarbon* 51(4):1151-1164, Reimer, et al., 2009, *Radiocarbon* 51(4):1111-1150,

Stuiver, et al., 1993, *Radiocarbon* 35(1):137-189, Oeschger, et al., 1975, *Tellus* 27:168-192

#### Mathematics used for calibration scenario

A Simplified Approach to Calibrating C14 Dates

Talma, A. S., Vogel, J. C., 1993, *Radiocarbon* 35(2):317-322

## Beta Analytic Radiocarbon Dating Laboratory

4985 S.W. 74th Court, Miami, Florida 33155 • Tel: (305)667-5167 • Fax: (305)663-0964 • E-Mail: beta@radiocarbon.com

## CALIBRATION OF RADIOCARBON AGE TO CALENDAR YEARS

(Variables: C13/C12=-23:lab. mult=1)

Laboratory number: Beta-345277

Conventional radiocarbon age: 330±30 BP

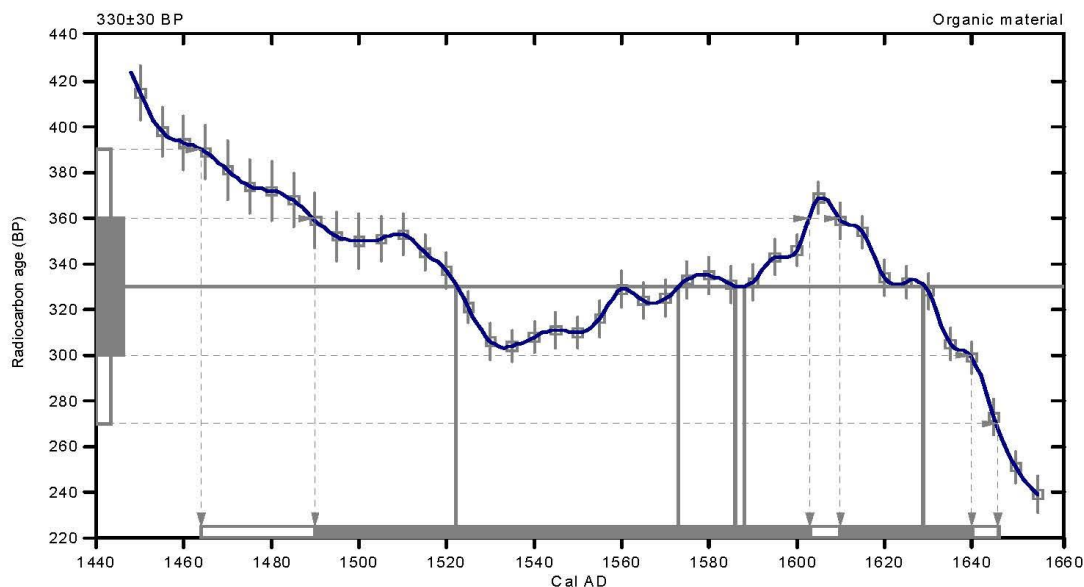
2 Sigma calibrated result: Cal AD 1460 to 1650 (Cal BP 490 to 300)  
(95% probability)

Intercept data

Intercepts of radiocarbon age  
with calibration curve:

Cal AD 1520 (Cal BP 430) and  
Cal AD 1570 (Cal BP 380) and  
Cal AD 1590 (Cal BP 360) and  
Cal AD 1590 (Cal BP 360) and  
Cal AD 1630 (Cal BP 320)

1 Sigma calibrated results: Cal AD 1490 to 1600 (Cal BP 460 to 350) and  
(68% probability) Cal AD 1610 to 1640 (Cal BP 340 to 310)



### References:

#### Database used

INTCAL09

#### References to INTCAL09 database

Heaton, et al., 2009, *Radiocarbon* 51(4):1151-1164, Reimer, et al., 2009, *Radiocarbon* 51(4):1111-1150,  
Stuiver, et al., 1993, *Radiocarbon* 35(1):137-189, Oeschger, et al., 1975, *Tellus* 27:168-192

#### Mathematics used for calibration scenario

A Simplified Approach to Calibrating C14 Dates

Talma, A. S., Vogel, J. C., 1993, *Radiocarbon* 35(2):317-322

## Beta Analytic Radiocarbon Dating Laboratory

4985 S.W. 74th Court, Miami, Florida 33155 • Tel: (305)667-5167 • Fax: (305)663-0964 • E-Mail: beta@radiocarbon.com



## CALIBRATION OF RADIOCARBON AGE TO CALENDAR YEARS

(Variables: C13/C12=-26:lab. mult=1)

Laboratory number: Beta-345278

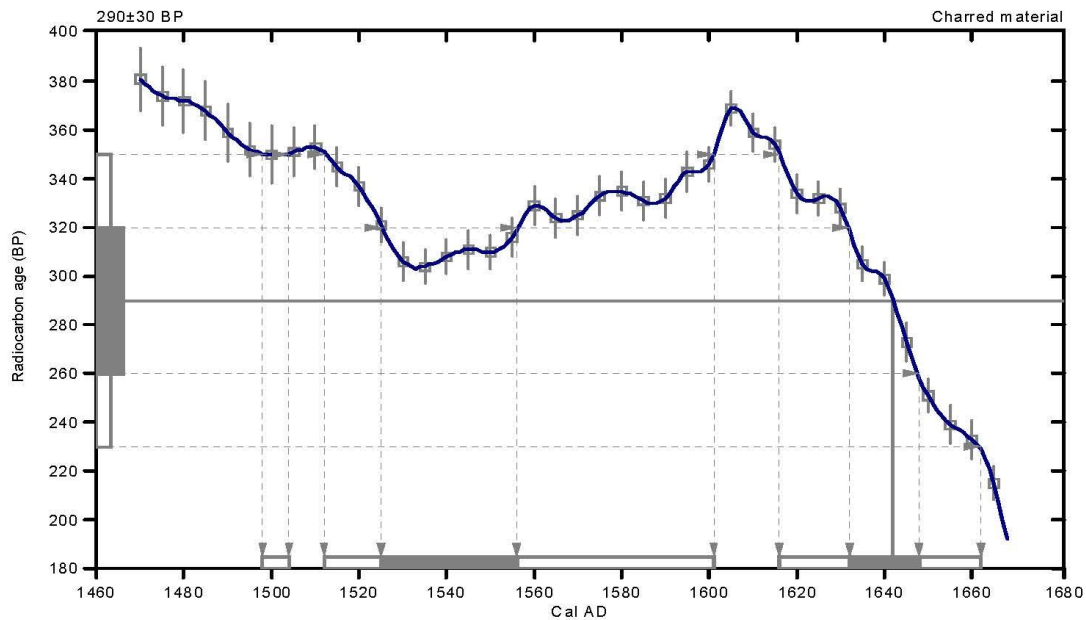
Conventional radiocarbon age:  $290 \pm 30$  BP

2 Sigma calibrated results: Cal AD 1500 to 1500 (Cal BP 450 to 450) and  
(95% probability) Cal AD 1510 to 1600 (Cal BP 440 to 350) and  
Cal AD 1620 to 1660 (Cal BP 330 to 290)

Intercept data

Intercept of radiocarbon age  
with calibration curve: Cal AD 1640 (Cal BP 310)

1 Sigma calibrated results: Cal AD 1520 to 1560 (Cal BP 420 to 390) and  
(68% probability) Cal AD 1630 to 1650 (Cal BP 320 to 300)



### References:

#### Database used

INTCAL09

#### References to INTCAL09 database

Heaton, et al., 2009, *Radiocarbon* 51(4):1151-1164, Reimer, et al., 2009, *Radiocarbon* 51(4):1111-1150,

Stuiver, et al., 1993, *Radiocarbon* 35(1):137-189, Oeschger, et al., 1975, *Tellus* 27:168-192

#### Mathematics used for calibration scenario

A Simplified Approach to Calibrating C14 Dates

Talma, A. S., Vogel, J. C., 1993, *Radiocarbon* 35(2):317-322

## Beta Analytic Radiocarbon Dating Laboratory

4985 S.W. 74th Court, Miami, Florida 33155 • Tel: (305)667-5167 • Fax: (305)663-0964 • E-Mail: beta@radiocarbon.com



The University of Georgia

Center for Applied Isotope Studies  
RADIOCARBON AGE ANALYSIS REPORT

October 20, 2004

Dr. James T. Abbott  
Staff Geoarcheologist  
Cultural Resources Management  
Texas Department of Transportation  
Dewitt C. Greer State Highway Bldg.  
125 E. 11th Street  
Austin, TX 78701-2483

Dear Dr. Abbott,

Enclosed please find the results for the Radiocarbon ( $^{14}\text{C}$ ) analysis including Stable Isotope Ratio analysis ( $\delta^{13}\text{C}$ ) correction for the samples received by our laboratory on October 11, 2004.

<u>UGA#</u>	<u>Sample I.D.</u>	<u>Radiocarbon Age (YBP<math>\pm</math>1<math>\sigma</math>)</u>	<u><math>\delta^{13}\text{C}</math> Corrected Age (YBP<math>\pm</math>1<math>\sigma</math>)</u>	<u><math>\delta^{13}\text{C}</math> (Years corrected)</u>
14415	41LM49-1-6-1:	6,390 $\pm$ 50	6,660 $\pm$ 50	-8.41 (+271)
14416	41LM49-1-6-2:	4,200 $\pm$ 50	4,460 $\pm$ 50	-8.92 (+263)
14417	41LM49-1-6-5:	4,360 $\pm$ 40	4,640 $\pm$ 40	-8.01 (+278)
14418	41LM50-1-2-1:	121.4 pMC		-22.66 (+38)
14419	41LM50-71-7-1a:	190 $\pm$ 40	180 $\pm$ 40	-25.70 (-11)
14420	41LM50-71-7-2a:	340 $\pm$ 70	330 $\pm$ 70	-25.78 (-13)
14421	41LM51-13-7-1:	150 $\pm$ 50	130 $\pm$ 50	-26.44 (-23)
14422	41LM51-19-6a:	6,510 $\pm$ 50	6,750 $\pm$ 50	-10.49 (+237)
14423	41LM51-52-6a:	4,600 $\pm$ 50	4,870 $\pm$ 50	-8.77 (+265)
14424	41LM51-55-6a:	4,910 $\pm$ 40	5,220 $\pm$ 40	-6.02 (+311)
14425	41LM51-56-6a:	5,520 $\pm$ 50	5,790 $\pm$ 50	-8.74 (+266)
14426	41LM51-89-6a:	5,590 $\pm$ 50	5,860 $\pm$ 50	-8.71 (+266)

120 Riverbend Road • Athens, Georgia 30602-4702  
Telephone (706) 542-1395 • Fax (706) 542-6106 • [cais@uga.edu](mailto:cais@uga.edu)  
An Equal Opportunity/Affirmative Action Institution





The University of Georgia

Center for Applied Isotope Studies

Dr. James T. Abbott

October 20, 2004

page 2 of 2.

The above charcoal samples were pre-treated with acid, alkali and acid, shell with mild acid and collagen extracted from the bone sample all prior to processing for AMS dating.

Sample UGA14418 (bone 41LM50-1-2-1) was not datable due to its recent age, younger than 1950 AD. Percent Modern Carbon (pMC) was reported instead.

If you have any questions, or need additional information, please do not hesitate to call.

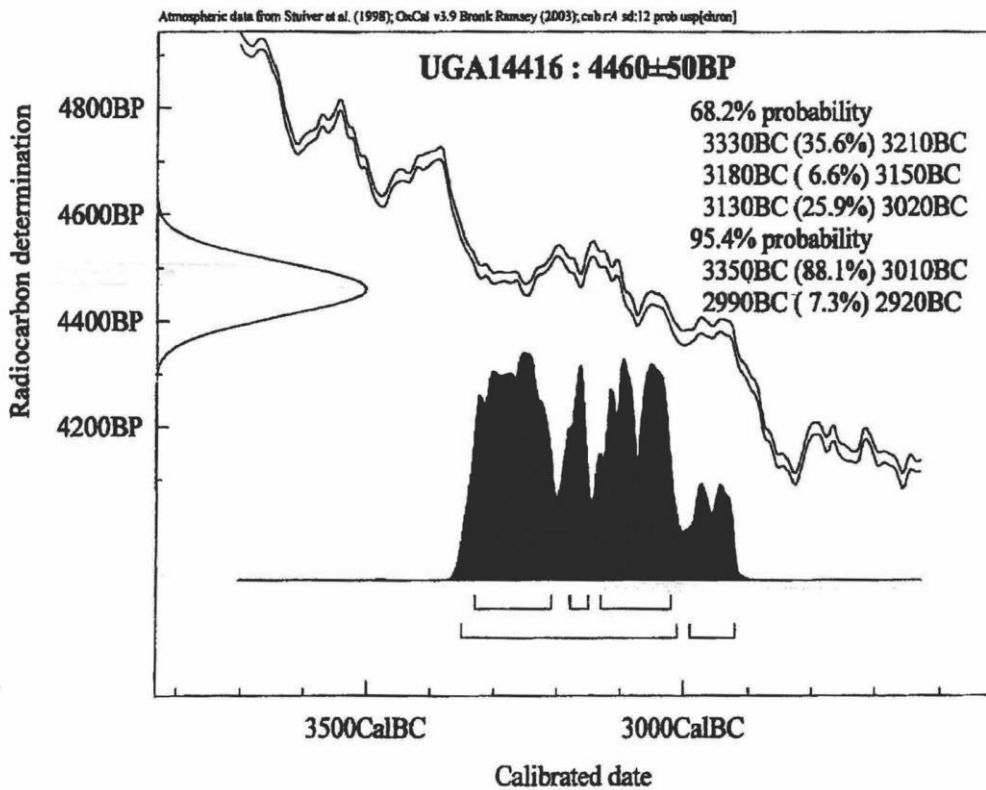
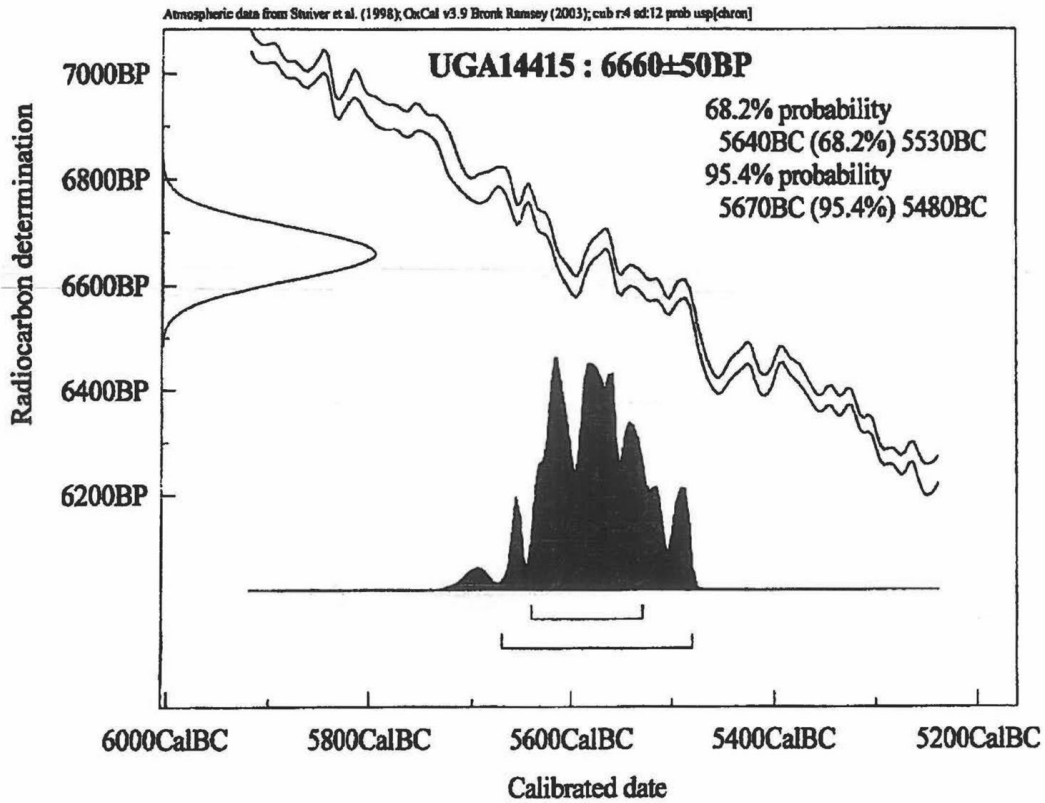
Sincerely,

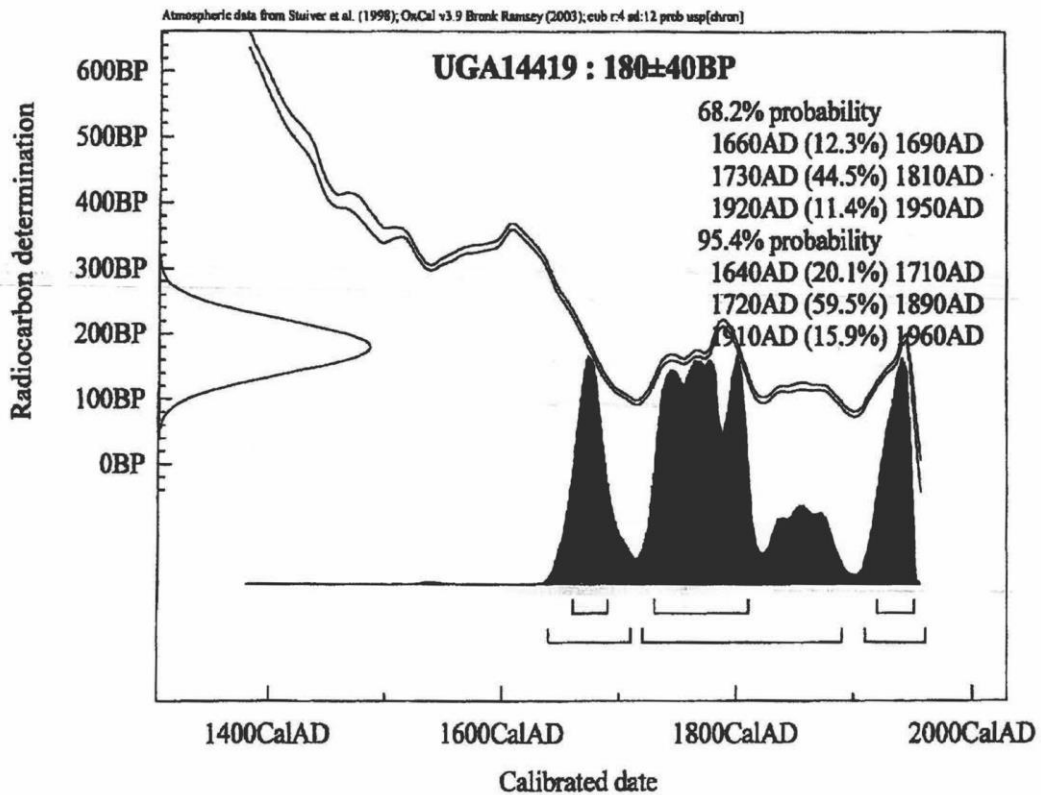
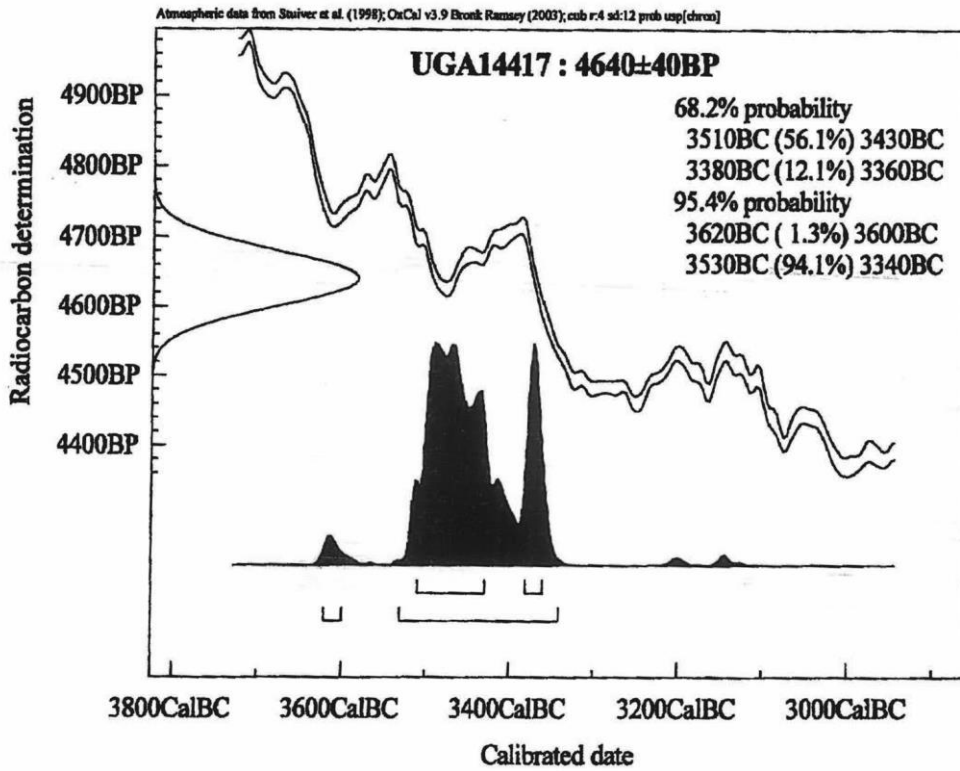
Randy Culp, Research Coordinator  
Center for Applied Isotope Studies

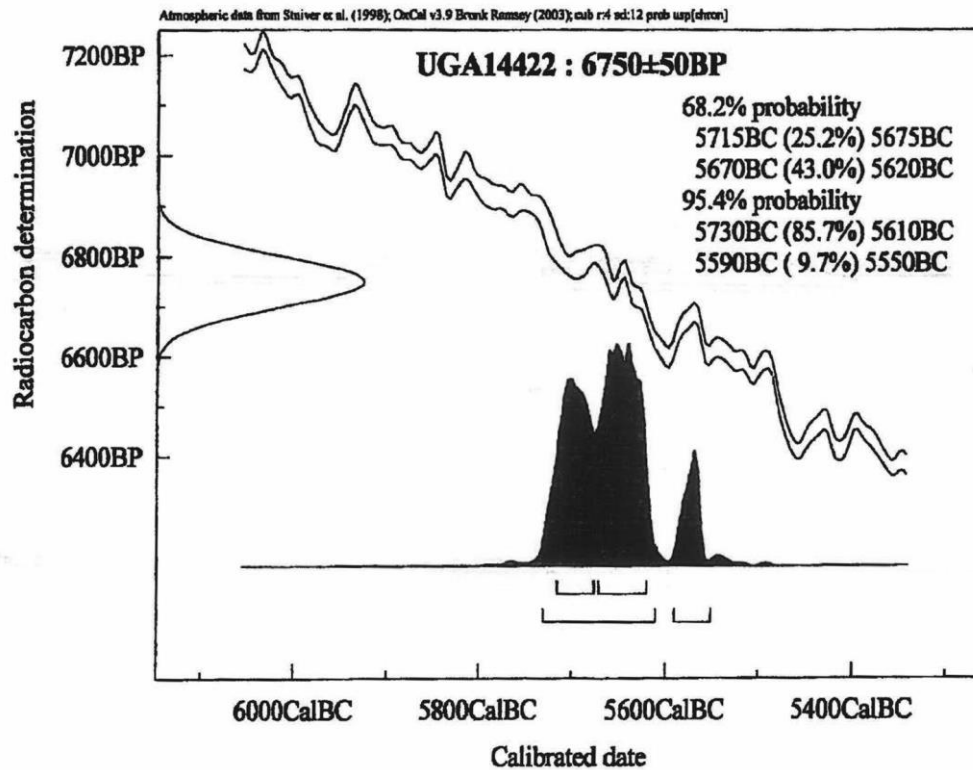
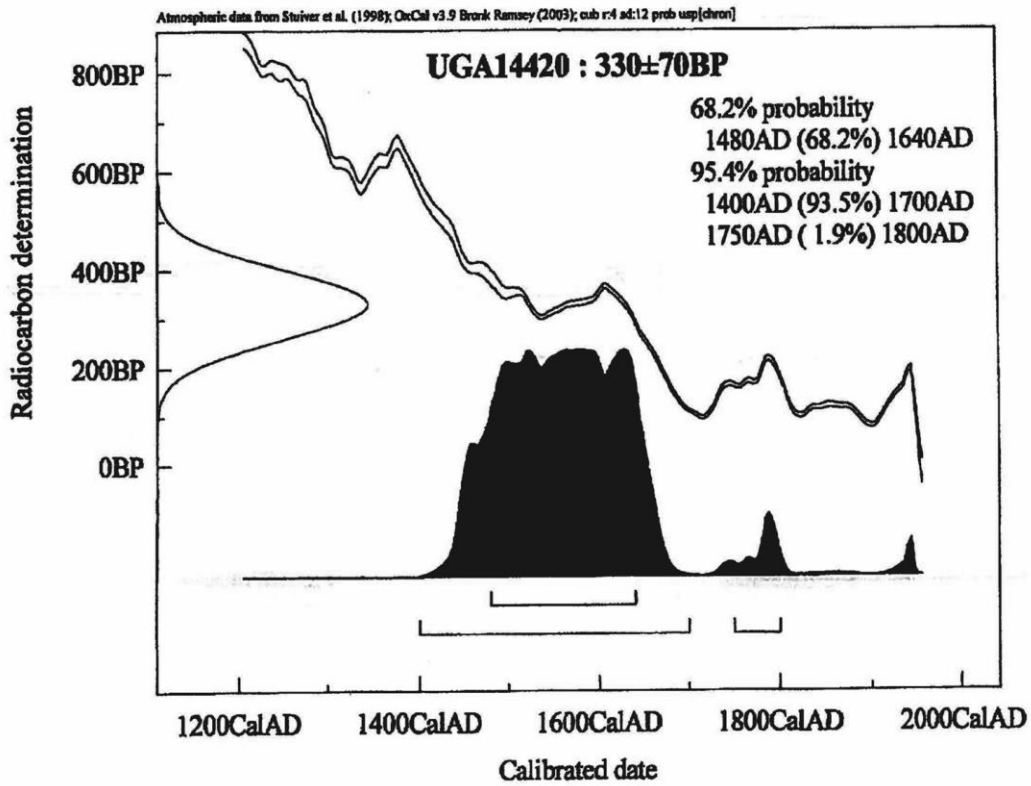
C.A.I.S. Inv. No. 6587

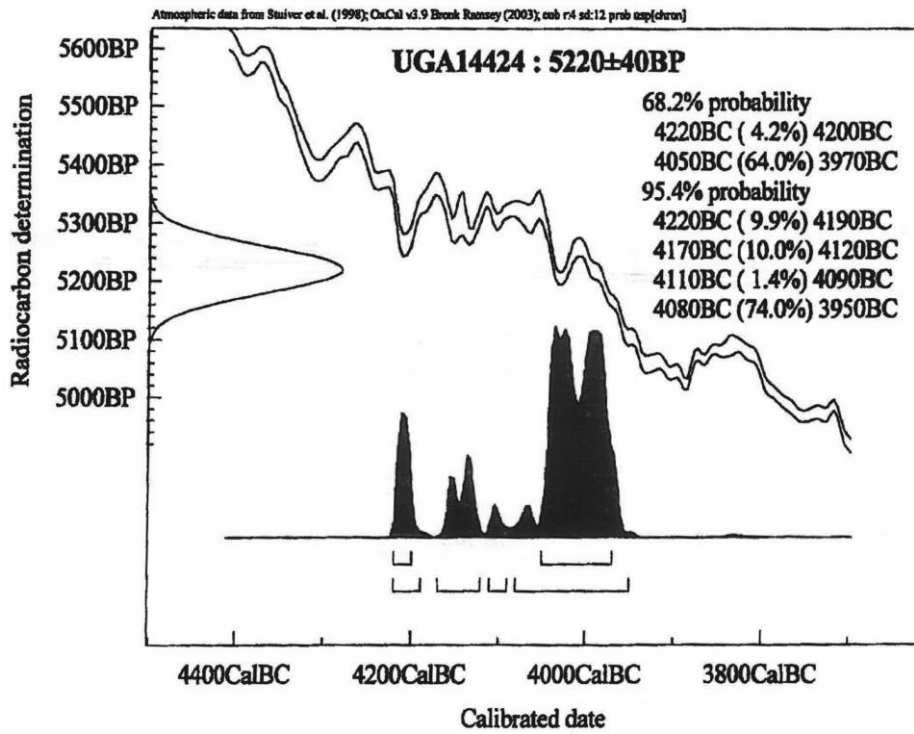
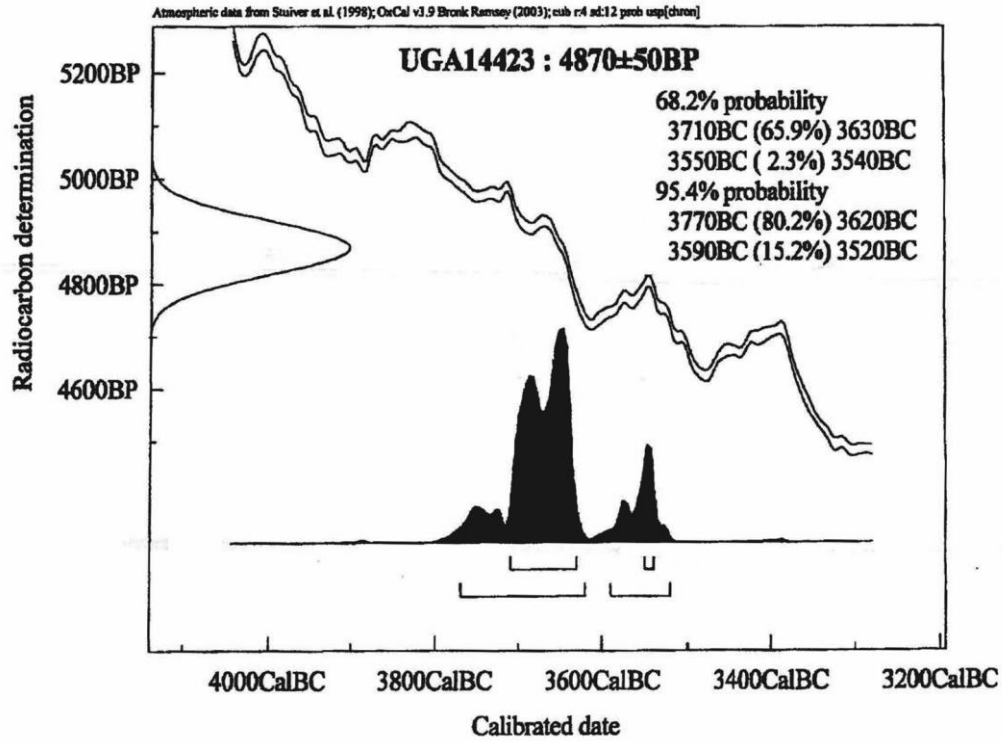
*All dates are reported in years before present (0 YBP=1950 A.D.). By international convention, the half-life of radiocarbon is taken to be 5568 years. Standardisation is with the National Institute of Standards and Technology's Oxalic Acid SRM-4990C, which is taken to be 129% modern (1950). The uncertainty in the reported age is at a one standard deviation confidence level (68% probability). Stable carbon isotope ratios ( $\delta^{13}C$ ) are given both as per mil (‰) difference from PDB-1 standard ratio and as the corrected radiocarbon age, in YBP. The corrected age facilitates the comparison of different materials which form in nature with different carbon isotope ratios. To obtain a corrected date, this correction factor should be added to the reported age (YBP).*

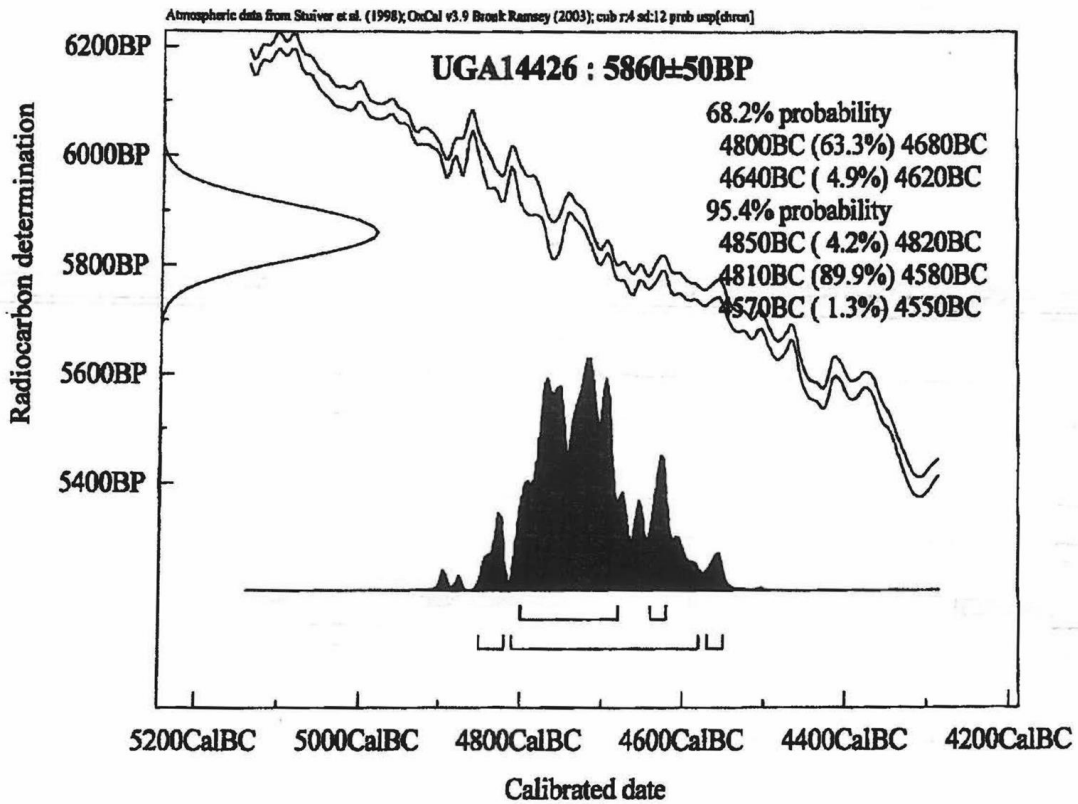
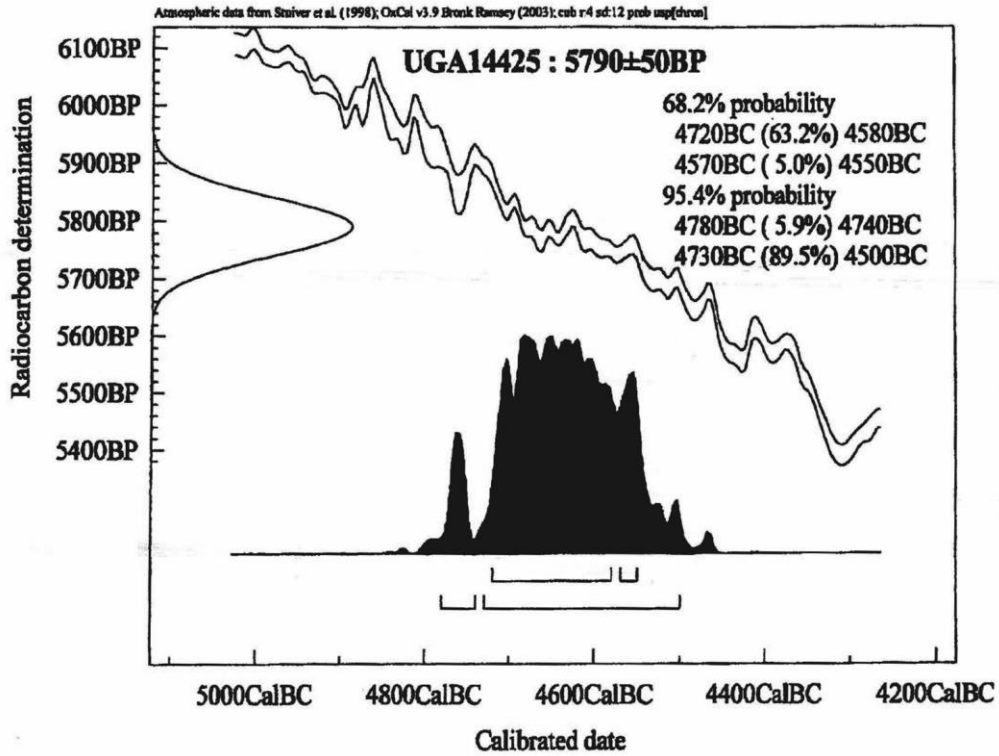
120 Riverbend Road • Athens, Georgia 30602-4702  
Telephone (706) 542-1395 • Fax (706) 542-6106 • [cais@uga.edu](mailto:cais@uga.edu)  
An Equal Opportunity/Affirmative Action Institution











*This page intentionally left blank.*

## **APPENDIX C**

### **RESIDUE AND USE-WEAR ANALYSIS OF STONE ARTIFACTS, LAMPASAS COUNTY, TEXAS, SITES 41LM50 AND 41LM51**

Prepared For:



TRC Environmental Corporation  
505 East Huntland Drive, Suite 250  
Austin, Texas 78752

Prepared By:

Bruce L. Hardy, Ph.D.  
Department Of Anthropology  
Kenyon, Collage  
Gambier, Oh 43022

June 2013



*This page intentionally left blank.*

## **RESIDUE AND USE-WEAR ANALYSIS OF STONE ARTIFACTS, LAMPASAS COUNTY, TEXAS, SITES 41LM50 AND 41LM51**

Bruce L. Hardy, Ph.D.

### **C.1 INTRODUCTION**

A sample of 35 artifacts was examined using microscopic residue and use-wear analyses in order to gain insight into their possible function. Site 41LM50 ( $N = 14$ ) is a short-term Late Prehistoric camp with small burned rock cooking features. One artifact (#66-10) is from a lower unknown component. Site 41LM51 ( $N = 21$ ) is a multi-component site. Nineteen of the artifacts are Late Archaic in age while one (#5-10) is from a Late Prehistoric Toyah component and one (#9-11) is from an Early Archaic Gower component.

### **C.2 METHODS**

Artifacts were examined under bright-field incident light using an Olympus BH30 microscope (magnification 50-500x). Images were recorded using a DinoEye USB camera (AM423XC) and DinoCapture 2.0 software. All residues observed were photographed and their location noted on a line drawing of each artifact. Identification of residues was based on comparison with a large modern reference collection and with published sources (Anderson-Gerfaud 1990; Beyries 1988; Brunner and Coman 1974; Catling and Grayson 1982; Crowther 2009; Hoadley 1990; Fullagar 1991; Teerink 1991; Hather 1993; Hardy 1994; Brom 1986; Kardulias and Yerkes 1996; Williamson 1996; Hardy and Garufi 1998; Pearsall 2000; Haslam 2004; Dove et al. 2005; Fullagar 2006; Genten et al. 2009; Warren 2009; Huffman et al. 2008). Identifiable residue categories include wood, bark, plant fibers, starch grains, calcium oxalate crystals, plant tissue, resin, hair, feathers, fish scales, skin, and bone (Hardy and Moncel

2011). Starch grains can potentially be mistaken for fungal spores or other materials and identification under reflected light is therefore considered preliminary (Haslam 2006; Loy 2006). For all identifications, a suite of related residues (e.g. hair fragments, collagen, bone or plant cells, starch grains, plant fibers) strengthened the confidence of the identification (Lombard and Wadley 2007). Calcium oxalate crystals (raphides) can be mistaken for rod-shaped calcite crystals (Crowther 2009). Treatment of putative raphides with acetic acid is necessary to confirm their identification.

Use-wear analysis to identify the relative hardness of the use-material and the use-action included the identification of striations, edge rounding, and microflake scars (Odell and Odell-Vereecken 1980; Mansur-Francomme 1986). Due to the potential overlap of polishes from different worked materials, polishes were identified as either “soft” (animal skin, muscle or soft plants) or “hard/high silica” (bone, antler, wood, or plants with high silica content) (Fullagar 1991; Hardy et al. 2001; Hardy 2004; Hardy et al. 2008). Residue distribution and co-occurrence of wear patterns were used to help determine if residues were use-related.

### **C.3 RESULTS**

#### **C.3.1 41LM50**

Twelve of the 14 artifacts examined showed either use-wear or residues which allowed a functional interpretation (see Figures C-1 and C-2). Hide and wood processing activities were the most common. Processing of birds may also be present. The two artifacts with unknown function both had poorly developed polishes and may have been used but it is not possible to determine the material.

#### ***Wood and Plant Processing***

Six artifacts, including three edge-modified flakes (#12-10, #18-11 and #61-10) and three biface fragments (#54-10, #66-10 and #71-10), show evidence consistent with wood processing.

Fragments of wood and plant tissue are typically associated with hard/high silica polish. Figure C-4 (artifact #12-10) shows a good example. A large fragment of wood is visible macroscopically. Numerous wood fragments are scattered on the dorsal and ventral surface. The small notch shows well developed polish and edge rounding. In one case, a biface fragment (#54-10) also has hair fragments on its surface. It is possible that this artifact was used for both hide and wood processing with the wear traces from the woodworking obscuring other wear traces. Alternatively, the hair fragments may not be related to use.

Four artifacts (#12-10, #17-11, #18-11 and #25-10) showed small particles which exhibited an extinction cross under cross-polarized light. This optical property is often used as a preliminary indication of the presence of starch grains (Fullagar 2006). Further analysis would be necessary to confirm this identification. One artifact shows microscopic rod-like structures which may be calcium oxalate crystals from plants. However, these can be confused with rod-like calcite crystals. The rod-like structures should be treated with acetic acid to confirm identification. If they are calcite crystals, they will dissolve when exposed to acetic acid (Crowther 2009).

### ***Hide Processing***

Four artifacts (#10-10, #10-11, #26-10 and #54-10) have hair and/or collagen fragments that suggest that they were used in hide working activities. This combination of residues makes the functional inference more confident (Lombard and Wadley 2007) and is supported by soft polish. These patterns are consistent with hide cutting or scraping.

### ***Other Activities***

Two edge-modified flakes (#17-11 and #53-10) have feather barbule fragments. Specimen #17-11 also shows plant fibers and possible starch grains (Figure C-3). The presence of soft polish, however, suggests that the flake may have been used in bird or feather processing. The other artifact (#53-10)

has no other residues, but has hard/high silica polish. This type of polish can be associated with bird processing activities if the artifact comes into contact repeatedly with bone. While it is possible to identify downy feather barbule fragments to the Order level, it is not always possible with isolated fragments (Brom 1986; Chandler 1916).

Several artifacts (i.e., #18-11 and #25-10) have multiple types of residue and wear which suggests they may have served multiple purposes. Refer to Figures C-1 and C-2 for a visual summary of the evidence on these tools.

### **C.3.2 41LM51**

Eighteen of 21 artifacts from 41LM51 have sufficient evidence to allow a functional interpretation (Figures C-5 and C-7). Many artifacts from this site appear washed. Only 15 artifacts had identifiable residues.

### ***Wood and Plant Processing Activities***

Five artifacts from 41LM51 have residues and wear associated with plant or wood processing. These include two edge-modified flakes (#5-10 and #88-10), a biface fragment (#69-11), a side scraper (#66-10), and a gouge (#83-10). In the case of a gouge, wood fragments are accompanied by collagen fragments. No use-wear was detected. This artifact may have had multiple uses, but both were likely to have been short in duration. In several cases, plant fibers are seen along with hard/high silica polish and striae. Plant fibers are elongated cells that may be found in both woody and non-woody plants (Dickson 2000). In these cases, the anatomy visible is insufficient to distinguish between these sources.

Five artifacts (#57-10, #61-10, #89-15, #90-12 and #91-13) have rod-like crystals which may be raphides. If they do prove to be raphides, it may help determine the type of plant in question. These residues would need to be treated with acetic acid to confirm that they are raphides (Crowther 2009).

### **Hide Processing**

Six artifacts (#51-10, #57-10, #61-10, #82-11, #85-12 and #8513) show evidence for use in hide processing activities. In most cases, hair fragments are found in association with soft polish and sometimes striae. In two cases (#57-10 and #85-13) collagen fragments are also present. Figure C-8 shows an edge-modified flake (#85-13) where notches on both sides of the flake appear used in hide processing. In other cases, such as #82-11, a single isolated hair fragment was observed. In this case, it is difficult to know if this is use-related or not. An edge-modified flake (#61-10) shows hair fragments and possible raphides along with hard/high silica polish and striae. The hard/high silica polish is not typically found with hide working. This tool may have served multiple uses with the hard/high silica polish obscuring wear from a hide working activity.

### **Other Activities**

Three artifacts (#9-11, #84-10, and #87-11) have hard/high silica polish but show no residues. For these artifacts, it is not possible to specify a use-material. Similarly, one biface fragment (#89-12) shows soft polish but no residues. One edge-modified flake (#70-10) has soft polish associated with red staining of unknown origin (Figure C-9). It is possible that the red staining is a mineral such as ochre that was being worked with the flake. Experimentation with this type of material or a different method of analysis would be necessary to confirm this identification.

## **C.4 DISCUSSION AND CONCLUSIONS**

Site 41LM50 consists of 13 artifacts from the Late Prehistoric period along with one from a lower unassigned component. Typical activities such as hide ( $N = 4$ ) and woodworking ( $N = 5$ ) are most common. In some cases, this even occurs on the same tool. For hide working, some use-wear traces are similar to those produced experimentally by Schultz (1992). They are insufficiently diagnostic,

however, and the hair fragments seen too degraded, to make any definitive link with bison processing per se. There does not appear to be any strong link between tool form and function. Even biface fragments have been used in both wood and hide processing activities. Feather barbule fragments were observed on two artifacts. Unfortunately, they are insufficiently diagnostic to attempt a more specific identification. Four artifacts show putative starch grains. These are all found in association with other residues. If these identifications are confirmed, they would again point to the use of tools on multiple materials. The one culturally unassigned artifact (#66-10) shows evidence of woodworking.

The sample from site 41LM51 contains 19 Late Archaic artifacts with one from an Early Archaic and one from a Late Prehistoric Toyah component. Once again, the most common activities seen are wood and hide processing. In this case, however, many of the artifacts appear to have been thoroughly washed and hence fewer residues were observed. Many of the artifacts appear to have been used, but it is only possible to talk of the relative hardness of the use-material. One edge-modified flake (#70-10) with a slight notch has red staining confined to that area. This red staining is most likely mineral and could be ochre. Ochre is certainly recognizable on archeological specimens (see Lombard 2007) and has been implicated in hafting. If this red residue is linked to function, it would be in the processing of the mineral rather than hafting. The one Late Prehistoric artifact (#5-10) may have been used in plant processing while the Early Archaic artifact (#9-11) has only hard/high silica polish used in cutting activities.

## C.5 REFERENCES CITED

- Anderson-Gerfaud, P.  
1990 Aspects of behavior in the Middle Paleolithic: Functional analysis of stone tools from southwest France. In: *The Emergence of Modern Humans: An Archaeological Perspective*, edited by P. Mellars, pp. 389-418. Cornell University Press, Ithaca.
- Beyries, S.  
1988 *Industries Lithiques: Traçéologie et Technologie*. British Archaeological Reports International Series, London.
- Brom, T.  
1986 Microscopic identification of feathers and feather fragments of palearctic birds. *Bijdragen Tot De Dierkunde* 56:181-204.
- Brunner, H. and B. J. Coman  
1974 *The Identification of Mammalian Hair*. Inkata Press, Melbourne.
- Catling, D. and J. Grayson  
1982 *Identification of Vegetable Fibres*. Chapman and Hall, New York.
- Chandler, A. C.  
1916 A study of feathers, with reference to their taxonomic significance. University of California, *Publication Zoology* 13:243-446.
- Crowther, A.  
2009 Morphometric analysis of calcium oxalate raphides and assessment of their taxonomic value for archaeological microfossil studies. *Archaeological Science under a Microscope [Electronic Resource]: Studies in Residue and Ancient DNA Analysis in Honour of Thomas H. Loy*, edited by Michael Haslam [et al.]. *Terra Australis* 30:102-128.
- Dickson, W. C.  
2000 *Integrative Plant Anatomy*. San Diego: Harcourt.
- Dove, C. J., P. G. Hare and M. Heacker  
2005 Identification of ancient feather fragments found in melting alpine ice patches in southern Yukon. *Arctic* 58:38-43.
- Fullagar, R.  
1991 The role of silica in polish formation. *Journal of Archaeological Science* 18:1-24.
- 2006 Starch on Artifacts. In *Ancient Starch Research*, R. Torrence and H. Barton, editors, pp. 177-204. Walnut Creek: Left Coast Press.
- Genten, F., E. Terwinghe and A. Danguy  
2009 *Atlas of Fish Histology*. Enfield, New Hampshire: Science Publishers.
- Hardy, B. L.  
1994 Investigations of stone tool function through use-wear, residue and DNA analyses at the Middle Paleolithic site of La Quina, France. Unpublished Ph.D. dissertation, Indiana University.
- 2004 Neanderthal behaviour and stone tool function at the Middle Paleolithic site of La Quina, France. *Antiquity* 78:547-565.
- Hardy, B. L. and G. T. Garufi  
1998 Identification of woodworking on stone tools through residue and use-wear analyses: Experimental results. *Journal of Archaeological Science* 25:177-184.

- Hardy, B. L., M. Kay, A. E. Marks, and K. Monigal  
2001 *Stone tool function at the Paleolithic sites of Starosele and Buran Kaya III, Crimea: Behavioral implications*. Proceedings of the National Academy of Sciences, U.S.A. 98:10972-10977.
- Hardy, B. L. and M. H. Moncel  
2011 Neanderthal use of fish, mammals, birds, starchy plants and wood 125-250,000 Years Ago. *PLoS One*, 6(8), e23768.
- Hardy, B. L., M. Bolus, N. J. Conard  
2008 Hammer or crescent wrench? Stone-tool form and function in the Aurignacian of southwest Germany. *Journal of Human Evolution* 54:648-662.
- Haslam, M.  
2004 The decomposition of starch grains in soils: Implications for archaeological residue analyses. *Journal of Archaeological Science* 31:1715-1734.
- 2006 Potential misidentification of *in situ* archaeological tool-residues: starch and conidia. *Journal of Archaeological Science* 33:114-121.
- Hather, J.  
1993 *An Archaeobotanical Guide to Root and Tuber Identification*, Vol. I: Europe and South West Asia. Oxbow Books, Oxford.
- Hoadley, R.  
1990 *Identifying Wood: Accurate Results with Simple Tools*. Taunton Press, Newtown.
- Huffman, D., L. Tiffany, G. Knaphus, and R. Healy  
2008 *Mushrooms and Other Fungi of Midcontinental United States*. Iowa City: University of Iowa.
- Kardulias, N. and R. Yerkes  
1996 Microwear and metric analysis of threshing sledge flints from Greece and Cyprus. *Journal of Archaeological Science* 23:657-666.
- Lombard, M.  
2007 The gripping nature of ochre: the association of ochre with Howiesons Poort adhesives and Later Stone Age mastics from South Africa. *Journal of Human Evolution* 53(4):406-419.
- Lombard, M. and L. Wadley  
2007 The morphological identification of micro-residues on stone tools using light microscopy: progress and difficulties based on blind tests. *Journal of Archaeological Science* 34:155-165.
- Loy, T.  
2006 Optical properties of potential look-alikes. In *Ancient Starch Research*, edited by R. Torrence, and H. Barton, p. 123. Walnut Creek, California, Left Coast Press.
- Mansur-Francomme, M. E.  
1986 *Microscopie du Matériel Lithique Préhistorique: Traces d'Utilisation, Altération Naturelles, Accidentelles, et Technologiques*. National Centre for Scientific Research, Paris.
- Odell, G. and F. Odell-Vereecken  
1980 Verifying the reliability of lithic usewear assessments by "blind tests": The low-power approach. *Journal of Archaeological Science* 7:87-120.
- Pearsall, D.  
2000 *Paleoethnobotany: A Handbook of Procedures*. Second edition, Academic Press, New York.

Schultz, J. M.

1992 The use-wear generated by processing bison hides. *The Plains Anthropologist* 37(141):333-351.

Teerink, B. J.

1991 *Hair of West European Mammals: Atlas and Identification Key*. Cambridge University Press, Cambridge

Williamson, B. S.

1996 Preliminary stone tool residue analysis from Rose Cottage Cave. South Africa. *Journal of Field Archaeology* 5:36-44.

Warren, R.

2009 The potential role of fish in the diet of Neanderthals. Unpublished senior honors thesis. Kenyon College, Gambier, Ohio.

**Table C-1. Results for 41LM50.**

<b>PNUM</b>	<b>Tool type</b>	<b>Residues</b>	<b>Use-wear</b>	<b>Functional Interpretation</b>
10-10	Edge-modified	Hair, collagen	Soft polish, microflake scars	Scraping hide
10-11	Edge-modified	Hair, collagen	Soft polish	Cutting hide
12-10	Edge-modified	Wood, plant tissue, Possible starch grains	Hard/high silica polish	Scraping wood
17-11	Edge-modified	Feather barbule, plant fiber, possible starch grains	Soft polish	Cutting bird?
18-11	Uniface/?graver	Possible starch grains, hair, wood	Soft polish	Multiple uses?
25-10	Edge-modified	Plant fibers, hair, Possible starch grains	Hard/high silica polish, striae	Multiple uses?
26-10	Side scraper	Hair, collagen	Soft polish	Scraping hide
48-10	Side scraper	-----	Light polish	Unknown
53-10	Edge-modified	Feather	Hard/high silica polish	Scraping Hard/high silica, bird
54-10	Biface fragment	Hair, wood	Hard/high silica polish	Scraping hide and wood
61-10	Edge-modified	Wood, plant fibers, hair (isolated)	Hard/high silica polish	Scraping wood/fibrous plant
66-10	Biface fragment	Wood, possible raphides	Hard/high silica polish	Cutting wood/plant
71-10	Biface fragment	Wood	Hard/high silica polish	Scraping wood
71-12	graver	-----	Light polish	Unknown



**Table C-2. Results for 41LM51.**

<b>PNUM</b>	<b>Tool type</b>	<b>Residues</b>	<b>Use-wear</b>	<b>Functional Interpretation</b>
5-10	Edge-modified	Plant fiber, plant tissue	Entire surface polished, striae	Cutting plant?
9-11	Edge-modified	-----	Hard/high silica polish	Cutting hard/high silica
51-10	Biface fragment	Hair	Soft polish, striae	Scraping hide
57-10	Edge-modified	Hair, collagen, possible raphides	Soft polish	Cutting hide
61-10	Edge-modified	Possible raphides, hair	Hard/high silica polish, striae	Multiple uses?
66-10	Side scraper	Wood, plant fibers	Hard/high silica polish, striae, edge rounding	Scraping wood
69-11	Distal biface frag	Wood	Hard/high silica polish, striae	Scraping wood
70-10	Edge-modified	Red staining	Soft polish	Scraping mineral?
76-10	Edge-modified	-----	Light polish	Unknown
79-14	Edge-modified	-----	Light polish	Unknown
82-11	Edge-modified	Hair (1 isolated)	Striae	Cutting hide?
83-10	Gouge	Wood, collagen	-----	Cutting wood, hide?
84-10	Edge-modified	-----	Hard/high silica polish, microflake scars	Cutting hard/high silica
85-12	Edge-modified	Collagen	Soft polish	Cutting hide
85-13	Edge-modified	Hair, collagen	Soft polish, striae	Scraping hide
87-11	Edge-modified	-----	Hard/high silica polish, striae	Cutting Hard/high silica
88-10	Edge-modified	Plant fibers	Hard/high silica polish, microflake scars, striae	Cutting hard plant
89-12	Biface fragment	-----	Soft polish	Scraping soft
89-15	Edge-modified	Possible raphides	Hard/high silica polish, edge rounding	Cutting Hard/high silica
90-12	Edge-modified	Possible raphides	Hard/high silica polish, microflake scars	Cutting Hard/high silica plant?
91-13	Graver	Possible raphides	-----	Unknown

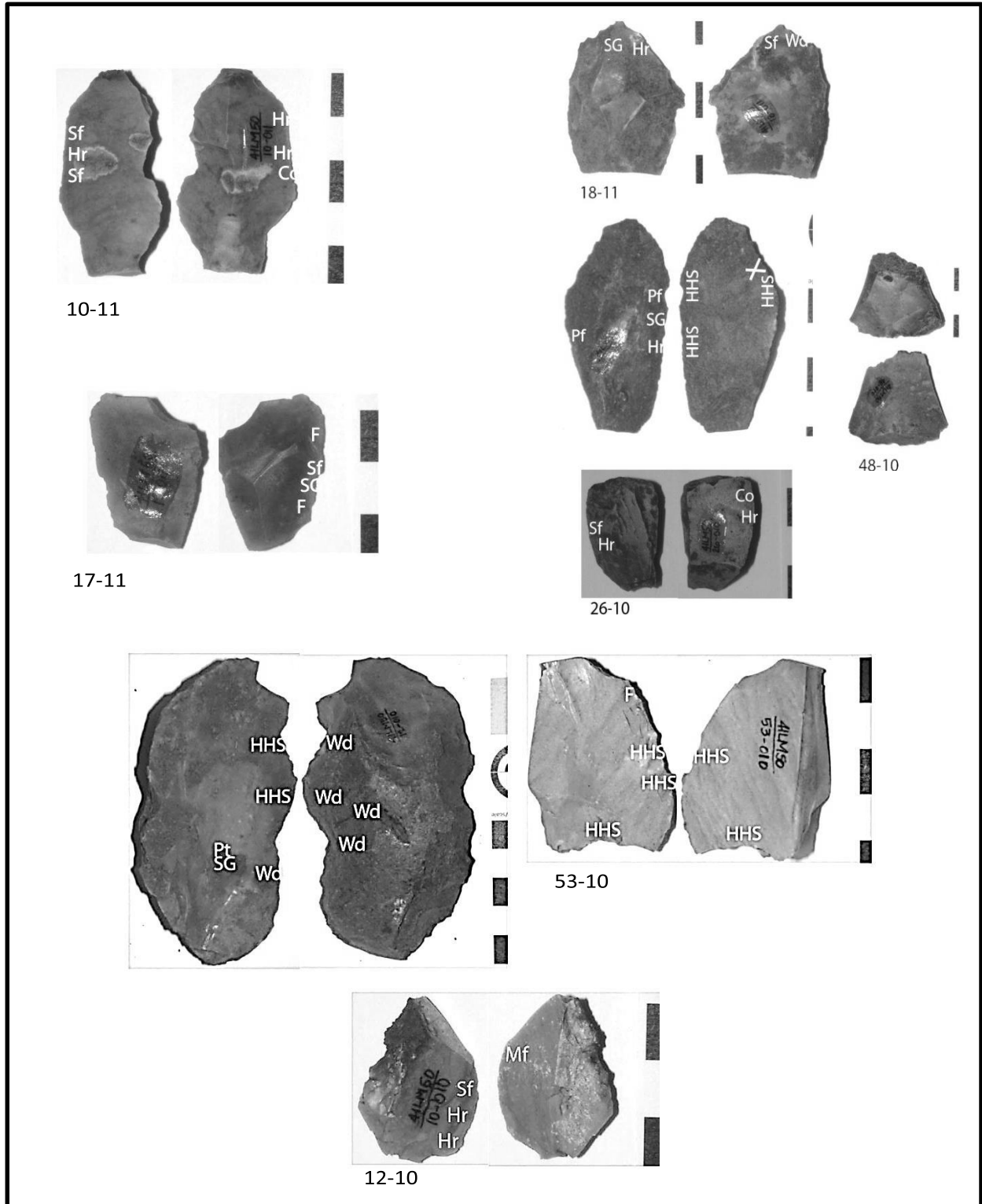


Figure C-1. Visual summary of results from 41LM50.

Bar scale in centimeters.

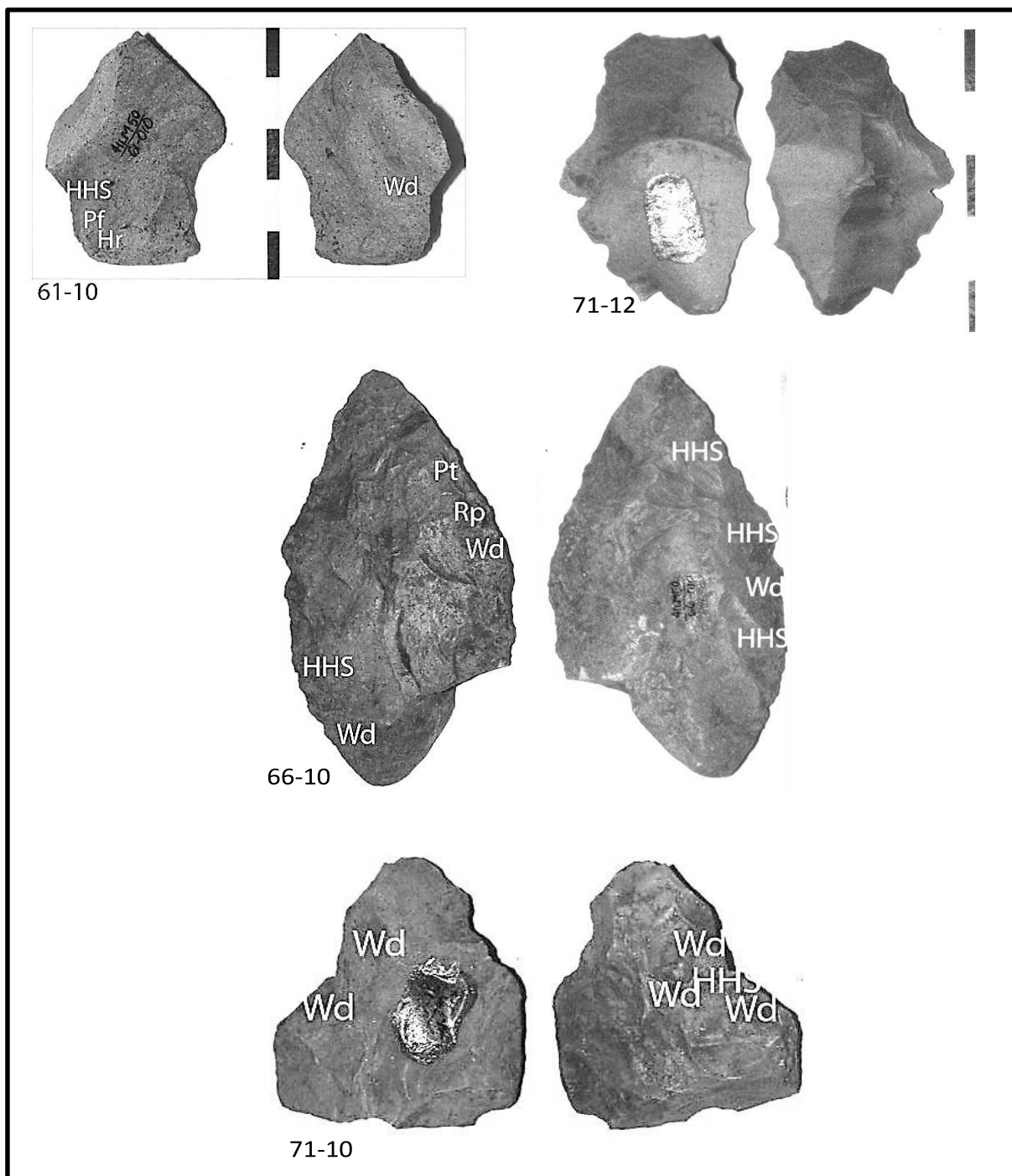


Figure C-2. Visual summary of results from 41LM50.

Bar scale in centimeters.

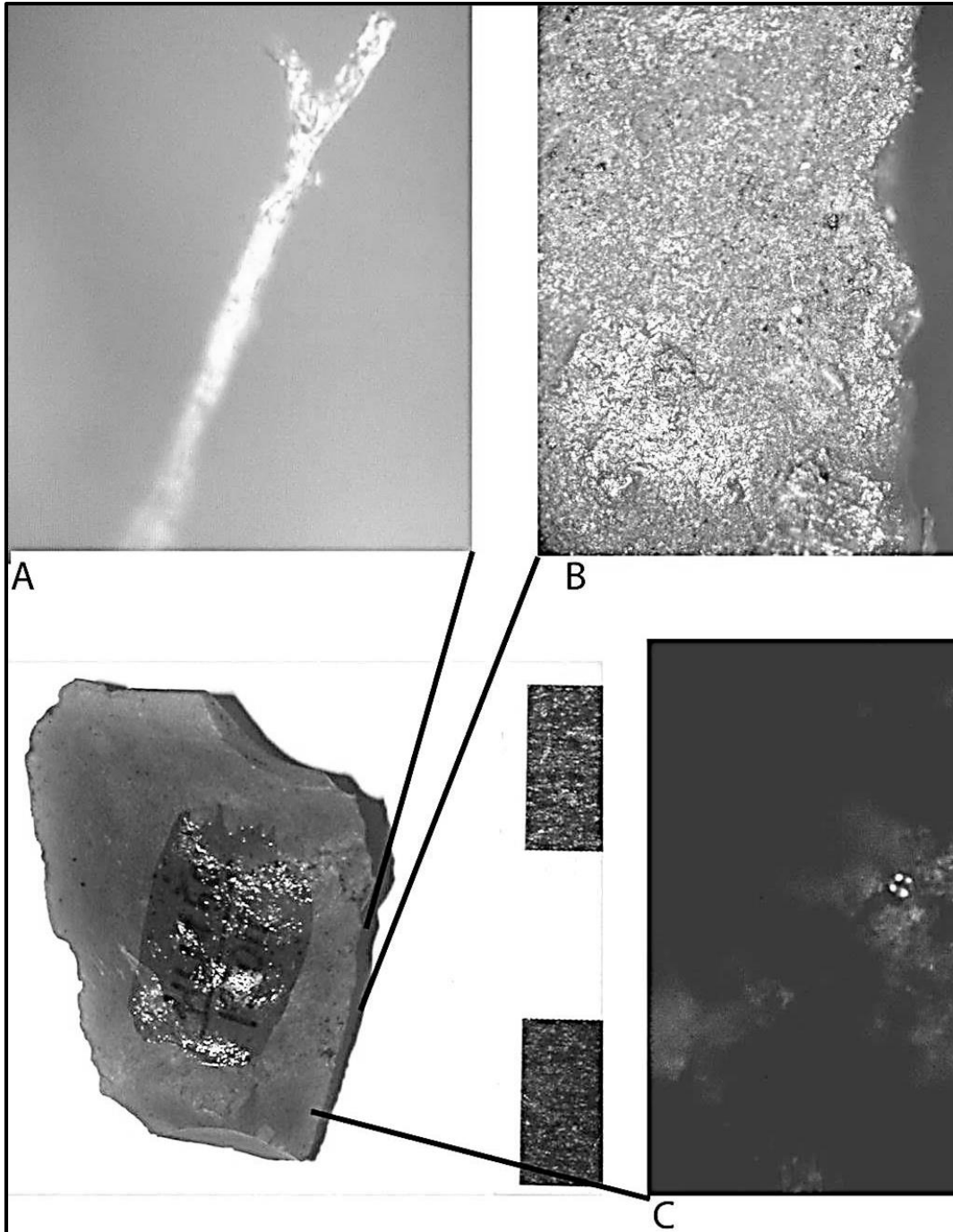


Figure C-3. Site 41LM50, #17-11.

- A) Downy barbule fragment (original magnification 500x)
- B) Soft polish (O.M. 100x)
- C) Putative starch granule showing extinction cross under cross- polarized light (O.M. 500x).

Bar scale in centimeters.

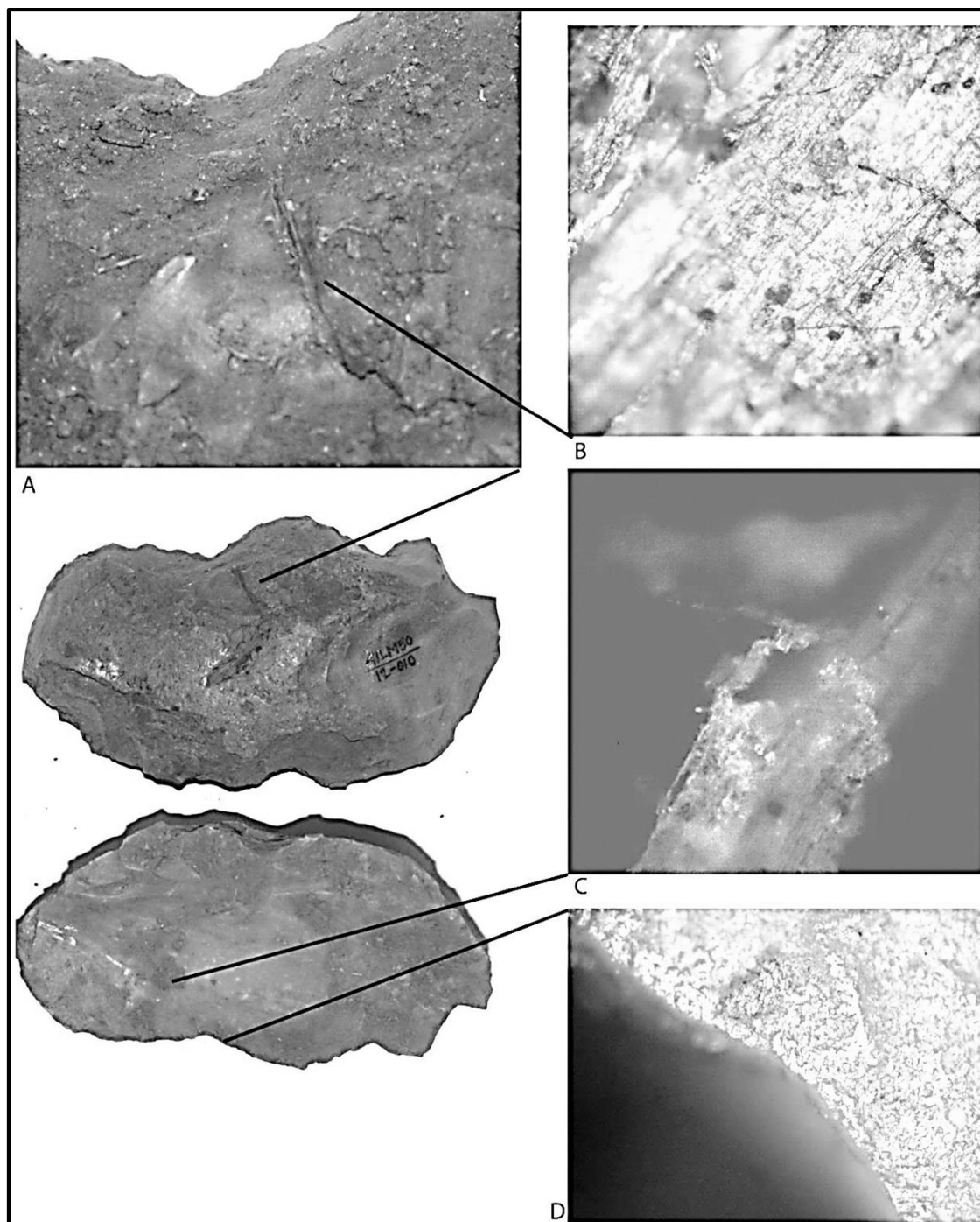


Figure C-4. Site 41LM50, #12-10.

- A) Large fragment of wood visible macroscopically
- B) Wood fragment (O.M. 100x)
- C) Plant fragment with possible starch grain (O.M. 500x, cross-polarized)
- D) Hard/high silica polish and edge rounding (O.M. 100x).

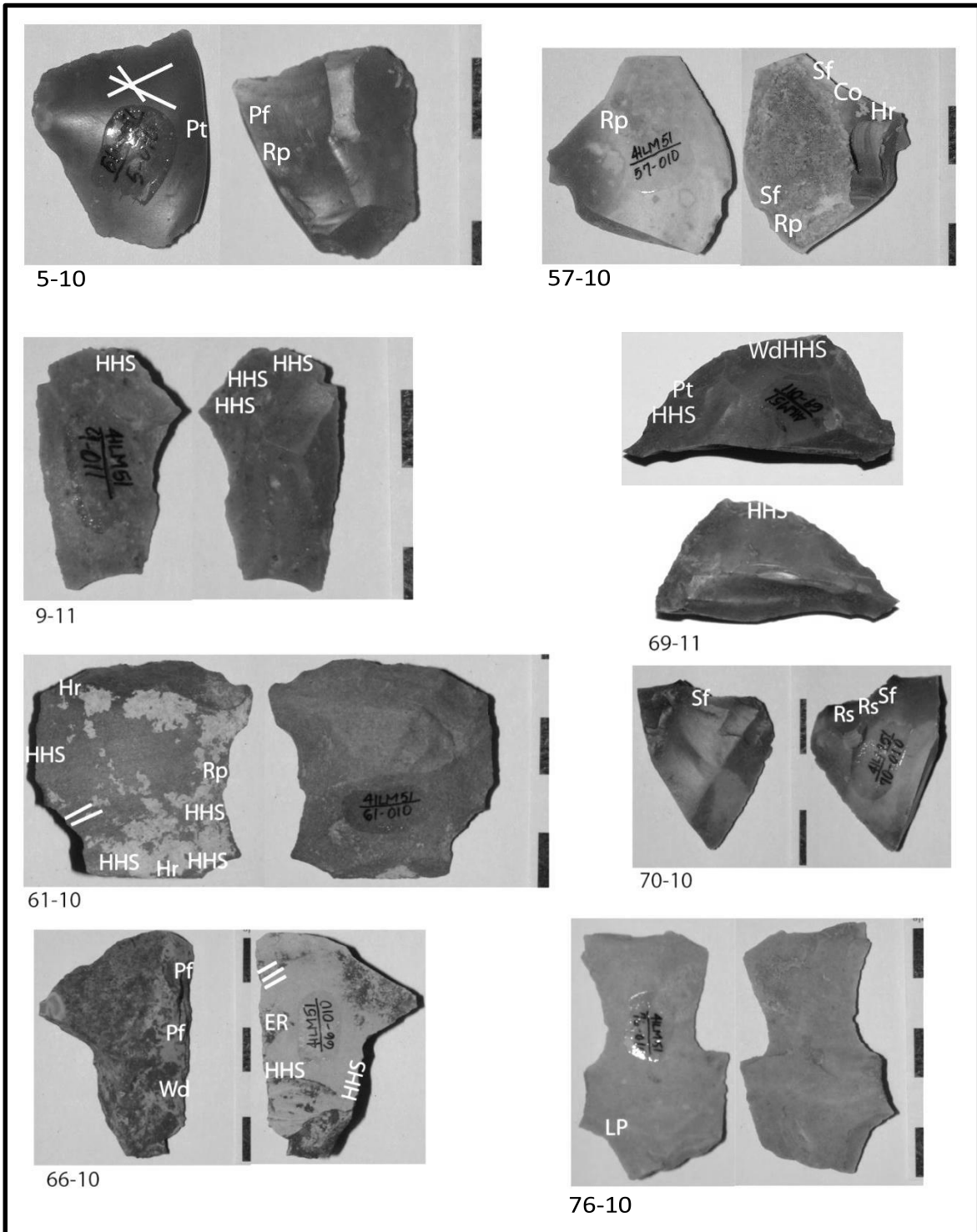


Figure C-5. Summary of results from 41LM51.

Bar scale in centimeters.

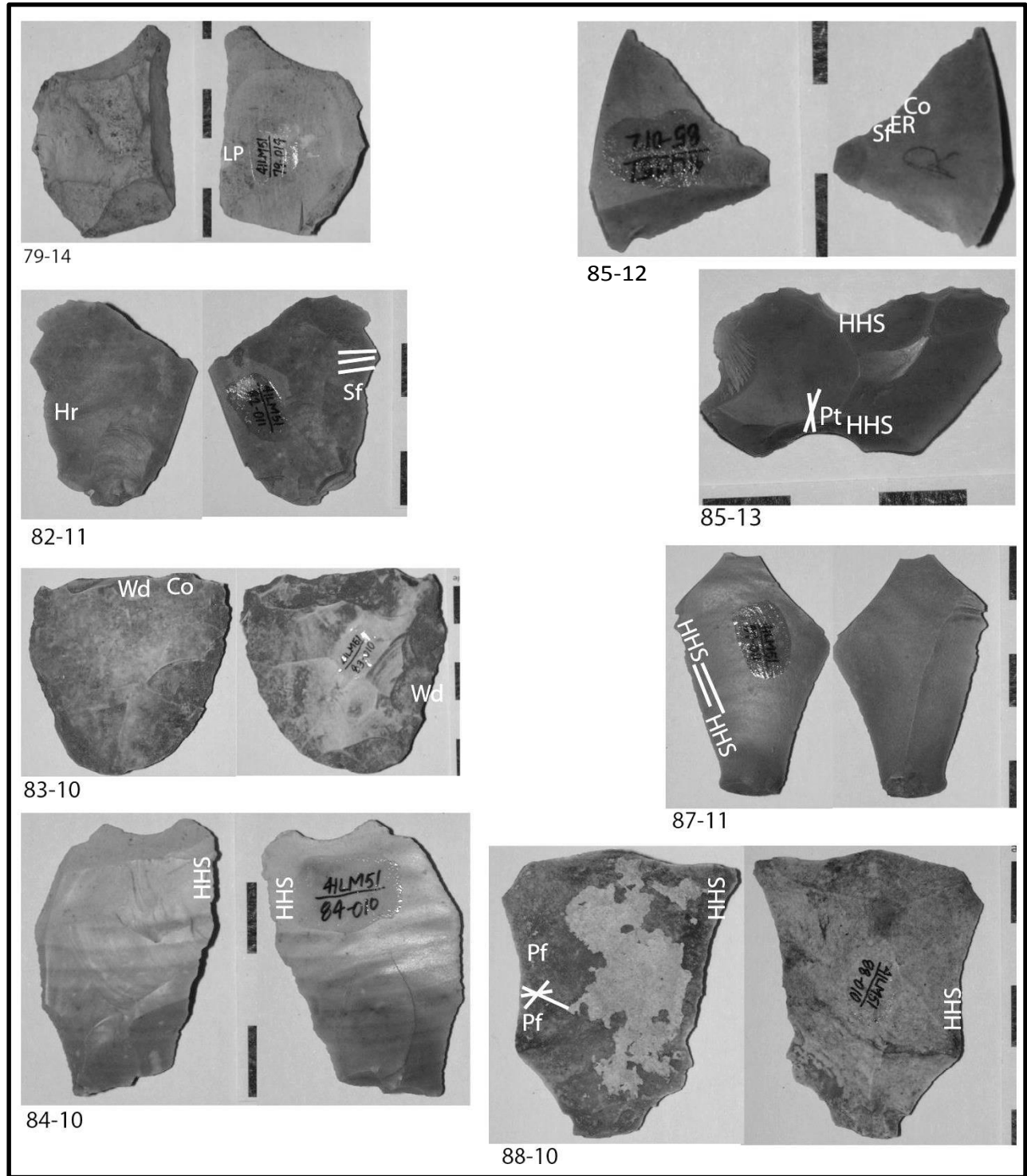


Figure C-6. Summary of results from 41LM51.

Bar scale in centimeters.

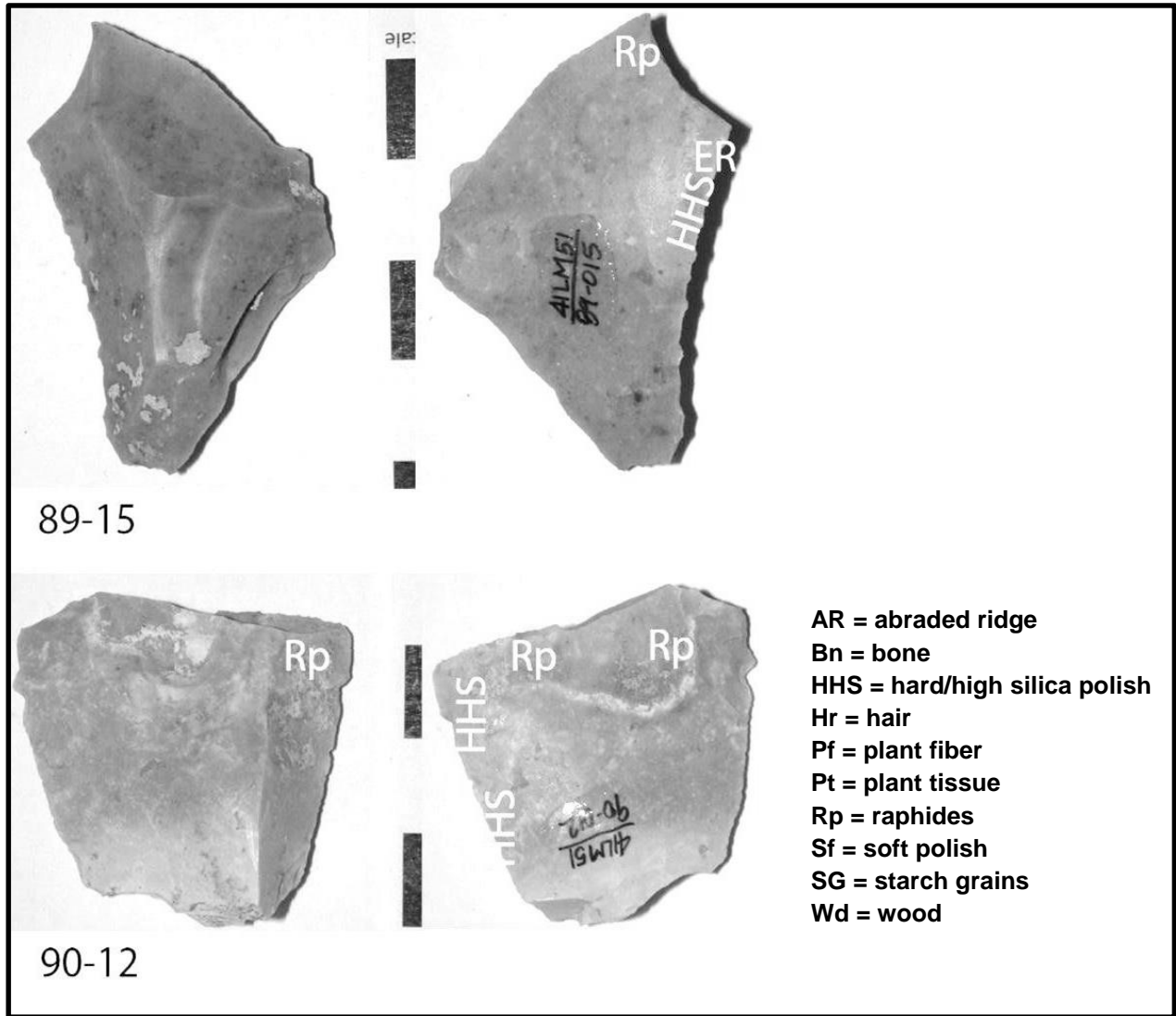


Figure C-7. Summary of results from 41LM51.

(Note: #s 51-10, 89-12, and 91-13 not pictured, see Table C-2 for results).

Bar scale in centimeters.



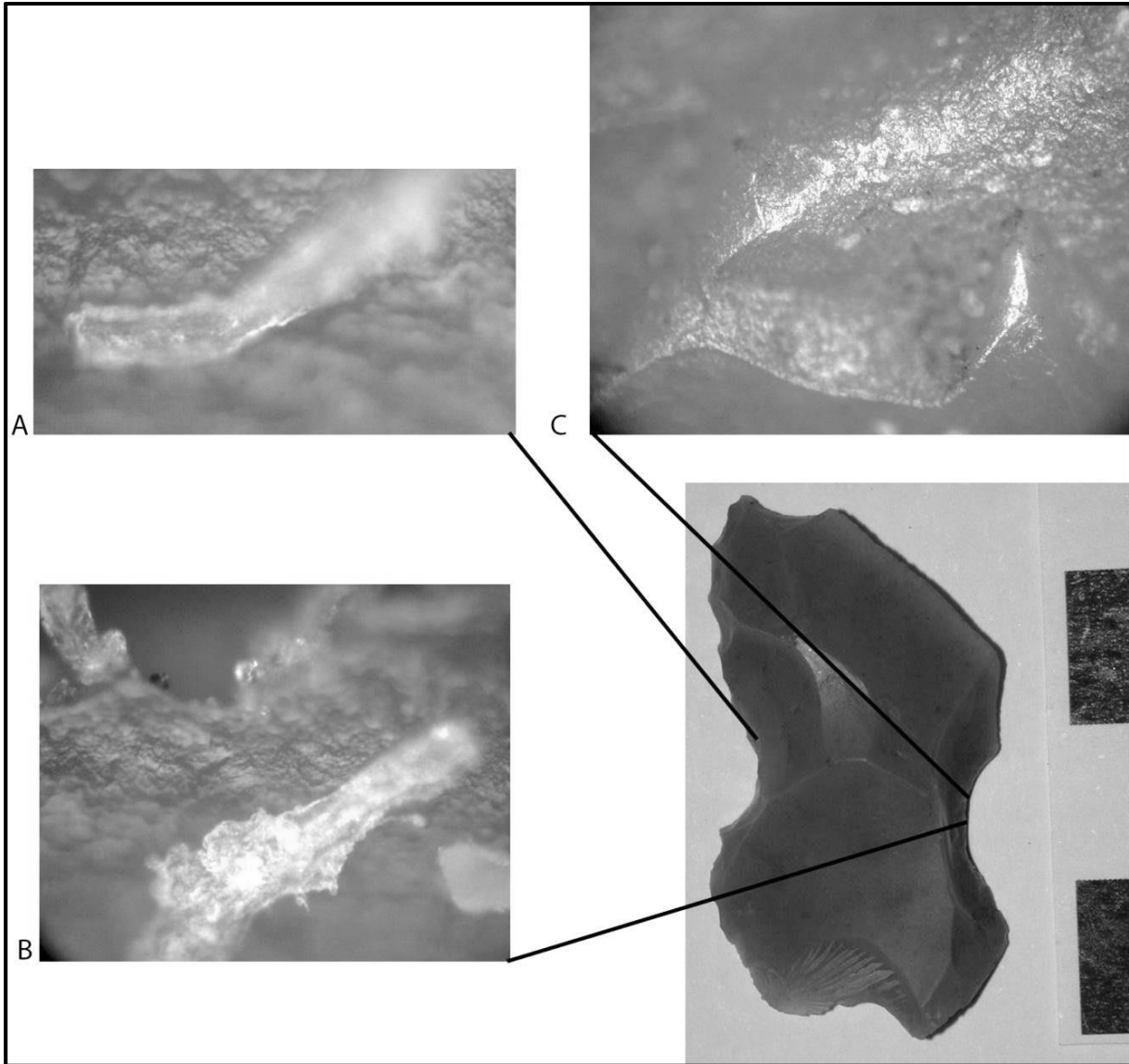
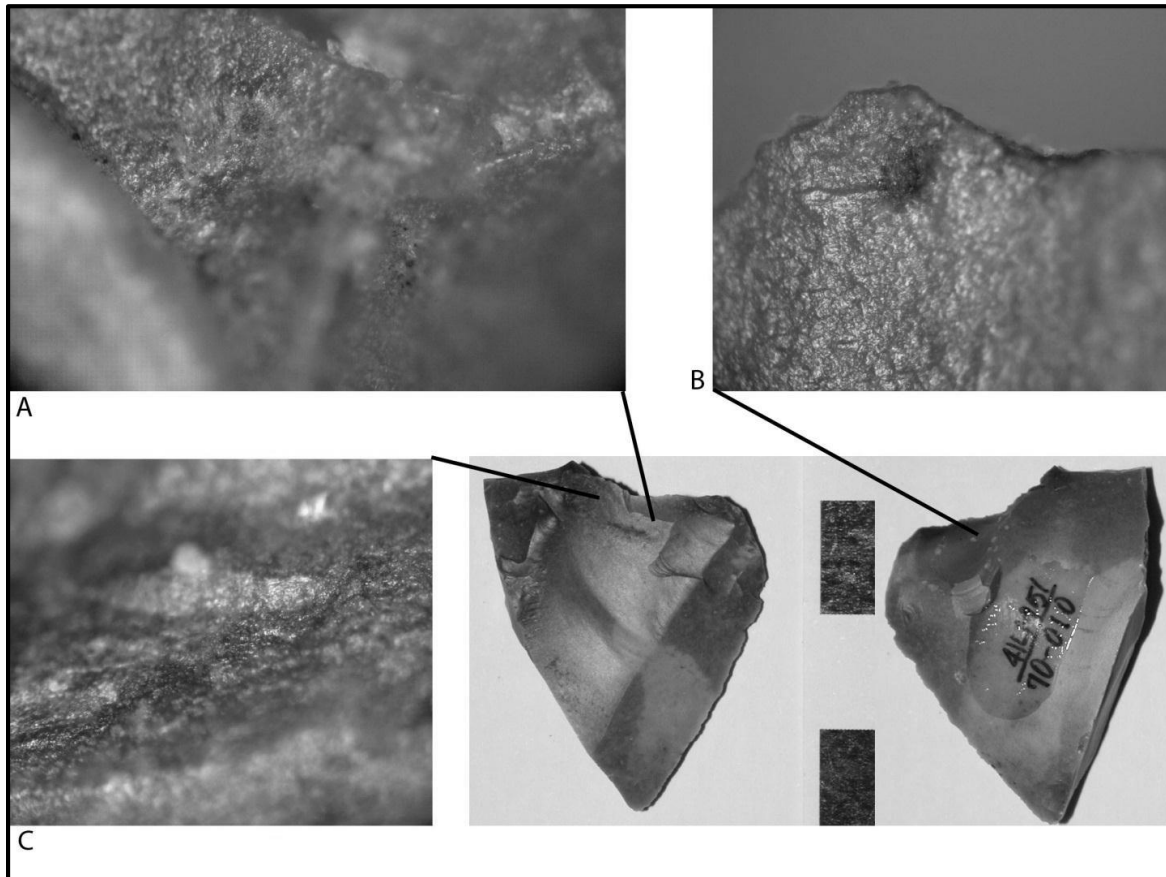


Figure C-8. Site 41LM51, #85-13.

- A) Hair fragment (O.M. 100x)
- B) Collagen fragment (O.M. 100x)
- C) Soft polish (O.M. 100x).

Bar scale in centimeters.



**Figure C-9. Site 41LM51, #70-10.**

(A,B,C) shows red staining and polish located near notched area on dorsal and ventral surfaces (O.M. 100x).

Bar scale in centimeters.

*This page intentionally left blank.*

## **APPENDIX D**

# **STARCH ANALYSIS OF SIXTY SAMPLES, LAMPASAS COUNTY, TEXAS**

Prepared for:



TRC Environmental Corporation  
505 East Huntland Drive, Suite 250  
Austin, Texas 78752

Prepared by:

Linda Perry, Ph.D.  
Executive Director

The Foundation for Archeobotanical Research in Microfossils  
P.O. Box 37  
Fairfax, VA 22038

June 2013

*This page intentionally left blank.*

## **STARCH ANALYSIS OF SIXTY SAMPLES, LAMPASAS COUNTY, TEXAS**

Linda Perry, Ph.D.

### **D.1 INTRODUCTION TO STARCH GRAIN ANALYSES**

Archeobotanical investigators are constantly seeking new methods by which previously unobtainable data can be recovered. Among archeologists who work in regions characterized by the poor preservation of organic remains, the analyses of starch granules have proven particularly useful in accessing the residues of starchy root and tuber crops that have previously been invisible in the archeological record (Bryant 2003; Coil et al. 2003; Fullagar et al. 1998; Hall et al. 1989; Iriarté et al. 2004; Loy et al. 1992; Pearsall et al. 2004; Perry 2001, 2002, 2004, 2005, 2007; Perry and Quigg 2011a, 2011b; Perry et al. 2006, 2007, 2010; Piperno and Holst 1998; Piperno et al. 2000). These residues have proven to be tenacious survivors in harsh climates, and their preservation on the surfaces of lithic tools that were used in the processing of starch-bearing plants occurs consistently in archeobotanical investigations (Iriarté et al. 2004; Pearsall et al. 2004; Perry 2001, 2002, 2004, 2005, 2007, 2010; Perry and Quigg 2011a, 2011b; Perry et al. 2006, 2007; Piperno and Holst 1998; Piperno et al. 2000).

Investigations of the starchy remains of plant foods on the surfaces of archeological lithic tools began with simple analyses using chemical reagents that identified the residues in question as plant-derived storage starch (Bruier 1976) rather than animal tissue. Within the last fifteen years, however, archeologists have been successfully employing morphological criteria to identify plant taxa. The methods are almost identical to those used in the analysis of phytolith microfossils.

Just as different plants produce characteristically shaped leaves, flowers, and seeds, different genera and species make starch grains that are distinctive to and diagnostic for each taxon. The anatomical features that distinguish the starch of one species of plant from another have been noted by botanists (e.g., Denniston 1904; MacMasters 1964; Reichert 1913) and their methods have been expanded by archeobotanists who are now able even to distinguish wild from domesticated species in some plant families (Iriarté et al. 2004; Pearsall et al. 2004; Perry 2001, 2002, 2004; Piperno et al. 2000). Basic physical features that are comparable between modern reference specimens and archeological samples can be viewed using a light microscope and include gross morphological features such as shape and faceting, the location of and appearance of the hilum, and presence and patterning of lamellae (Iriarté et al. 2004; Loy 1994; Pearsall 2004; Perry 2004; Piperno and Holst 1998; Piperno et al. 2000). Fissuring and other internal patterning have also proven to be useful criteria for identification. The successful identification of starch granules relies upon the viewing of each granule in three dimensions to gain an accurate assessment of its morphological features.

Because starch granules differ morphologically between plants, their distinctive characteristics can often allow identification to the level of genus or species in archeological samples (e.g., Iriarté et al. 2004; Pearsall et al. 2004; Perry 2001, 2002, 2004, 2005, 2007; Perry et al. 2006, 2007; Piperno and Holst 1998; Piperno et al. 2000). The method has proven particularly useful in identifying the remains of plant tissues that would not usually be preserved as macroremains, such as the remnants of root and tuber crops (Bryant 2003; Coil et al. 2003; Fullagar et al. 1998; Hall et al. 1989; Iriarté et al. 2004; Loy et al. 1992; Pearsall et al. 2004; Perry 2001, 2002, 2004, 2005; Piperno and Holst 1998; Piperno et al. 2000). This role of starch analysis as a tool for revealing the significance of plant foods in the archeobotanical record also adds to our

understanding of the precontact significance of starchy seed crops like maize (*Zea mays*).

In a citation of preliminary results from an ongoing study, the archeological remains of maize starch have been extracted from 2000 year-old obsidian artifacts from the Honduran site of Copán (Haslam 2003, 2004). The starchy residues of maize were also successfully recovered and identified from a migmatite milling stone from Cueva de los Corrales 1 in Argentina (Babot and Apella 2003). In this case, the grinding stone was found to have multiple purposes, including the grinding of burned bone, presumable for a nonfood purpose. Starch analyses of ground stone artifacts from Real Alto have supported previously published phytolith studies that indicate the great antiquity of maize in Ecuador, and its role in subsistence during the Formative period (Pearsall et al. 2004). Seventeen examined artifacts from Real Alto yielded concentrations of maize starch granules ranging from one to more than ten granules per sampled tool. Other Neotropical studies have resulted in the recovery of more complex assemblages of starches.

Archeologists have recovered starch granules from maize, beans (*Phaseolus* sp.), and *Canna* from the Los Ajos mound complex in Uruguay (Iriarté et al. 2004). Maize starch granules were reported from three ground stone tools including one mano and two milling stone bases. Concentrations of maize starches ranged from two to eleven granules on tools from contexts dating from 3600 years before present to about 500 years before present (Iriarté et al. 2004: supplementary information). The starch data were combined with phytolith evidence and, together, these results introduce compelling evidence for the early development of a mixed subsistence economy in this region of South America. In other regions of the Neotropics starch analysis has been an essential tool in defining similar subsistence patterns that included the exploitation of root and tuberous food plants.

Starch granules of maize, manioc (*Manihot esculenta*), both wild type and domesticated yams (*Dioscorea* spp.), and arrowroot (*Maranta arundinacea*) have been recovered from edge-ground cobbles and grinding stone bases collected from the Aguadulce rock shelter as well as the sites of Monagrillo, La Mula, and Cerro Juan Diaz in Panama (Piperno and Holst 1998; Piperno et al. 2000). Edge-ground cobbles are characterized by faceting that is hypothesized to have resulted from the processing of root crops against larger grinding stone bases (Ranere 1975), and the analyses of the residual remains of plant tissues supports this hypothesis. However, the use of the milling stones does appear to have been more complex than previously believed. Maize remains were recovered from all twelve artifacts that bore starch (Piperno et al. 2000). The numbers of starch granules of maize per artifact ranged from one to twenty-five per artifact. Two starch granules of arrowroot occurred on a single artifact, manioc starch granules were recovered from three artifacts (one, five, and eight granules), and yam starch granules were found on the surfaces of three of the artifacts (two, three, and sixteen granules) (Piperno et al. 2000). These investigations resulted in the recovery of the oldest evidence for root and tuber crop cultivation in the Neotropics, with radiocarbon dates spanning from 5000 to 7000 B.P.

Starch granules of maize, yams, and arrowroot have also been recovered from twelve flake and three ground stone tools collected from Pozo Azul Norte 1 and Los Mangos del Parguaza in Venezuela (Perry 2001, 2002, 2004, 2005). These sites date from the middle first century A.D. to contact. As in the above-cited set of studies, maize remains were recovered from every examined artifact and ranged in number from two to fifty-one per artifact. Additionally, four granules of yam starch were recovered from two flake tools, four flake tools yielded four granules of guapo (*Myrosma* sp.) starch, and seven starch granules from arrowroot were collected from five tools, one of which was a

ground stone artifact. These findings were significant in that five of the examined artifacts were chosen for study due to their hypothetical function as microlithic grater flakes from a manioc specific grater board. The evidence indicated a more complex function of these tools that did not include the processing of manioc.

More recent investigations have led to the recovery of direct evidence for contact between the highland Peruvian Andes and the lowland tropical forest to the east (Perry et al. 2006). This contact and interaction had been a significant component of Andean theory for decades, but direct evidence had been elusive until starch microfossils of arrowroot were collected from both sediment samples and lithic tools at the mid-elevation site of Waynuna (Perry et al. 2006). Further, the discovery and cataloging of a microfossil will allow for the recovery and understanding of the origins and subsequent dispersals of chili peppers (Perry et al. 2007), plants whose histories are poorly understood due to the lack of preservation of macroremains in the archeobotanical record. Remains of these plants have been successfully recovered throughout the Americas from ceramic sherds, lithic tools, and sediment samples dating from 6250 B.P. to European contact.

#### **D.1.1 Understanding the Relationship between Residues and Artifacts**

Early work on starch remains from Panamanian sites used stepwise analysis to support the direct association between starchy residues on tools and the tools' use (Piperno et al. 2000). These studies demonstrated that starch grains were not present in sediments adhering to stone tools or on unused parts of the lithics, but they did occur in the cracks and crevices of the tools on used surfaces, thus indicating that the residues were the result of the tools' use and not environmental contamination. Similar experiments have been undertaken independently by other researchers, and the results were equivalent.

In a study of obsidian artifacts recovered from an open air site in Papua New Guinea, the frequency of starch granules recovered from stone artifacts was compared to that present in the soil matrix immediate to the tool (Barton et al. 1998). The frequency of starch granules was found to be much higher on used artifacts than in the surrounding soil. Thus, the conclusion was drawn that the tools were not contaminated by environmental starch sources. Further, use-wear analyses were used in combination with the soil and starch analyses to assess the degree of association of starchy residues with the used surfaces of tools (Barton et al. 1998). The researchers found that, indeed, the occurrence of starch granules was highly correlated with obsidian tools that bore use-wear and was not correlated with unused tools.

In a study of starch residues occurring on stone pounding tools from the Jimmum site in north central Australia, the starch forms in soil samples were compared to those extracted from the artifacts (Atchison and Fullagar 1998). It was found that, although starch granules did occur in the soil matrices surrounding the tools, they were of different size and shape than those present on the pounding stones, and, therefore, are probably not from the same plant source. This result was interpreted as evidence that the tools had not been contaminated by soil-borne starches.

Another method for assessing whether or not starch residues are culturally deposited involves the analysis of control samples from noncultural contexts surrounding a site. If different types of starches, or different concentrations of starches, or no plant residue whatsoever are recovered from the control samples than are recovered from the artifacts undergoing testing, then one can be more secure that the residues are the remains of prehistoric food processing (Brieur 1976).

In addition to the study of association of microfossils with tool use, experimentation with processing methods has also been undertaken. In



Argentina, a researcher replicated ancient Andean methods of food processing and found that each different process resulted in diagnostic damage to starch granules in plant tissues including potato tubers (*Solanum tuberosum*) and quinoa seeds (*Chenopodium* spp.) (Babot 2003). Modern plant materials were subjected to freeze-drying, dehydration, roasting, charring, desaponification (a process particular to the preparation of quinoa), and grinding. It was found that fragments of starches that would probably otherwise be identified as unknowns or nonstarches are actually damaged starches. Further, with careful analysis, researchers can link damage patterns with processing techniques (Babot 2003). Experimentation with various cooking techniques has resulted in similar conclusions: cooked starches are identifiable as such, and different cooking techniques yield different patterns of damage (Henry et al. 2009).

Recent work at the Pipeline, Pavilion, and Corral sites in the Texas panhandle have demonstrated the utility of starch grain analysis in understanding the function of burned rocks in archeological contexts (Perry 2010; Perry and Quigg 2011a). Here, the analysis of burned rocks yielded starch grains that bore clear damage from boiling and secured the function of many burned rocks as boiling stones used for the cooking of wildrye. The analysis of other artifacts from the sites yielded wildrye starches bearing damage from grinding, thus indicating that the grain was probably milled into flour prior to cooking (Perry 2010; Perry and Quigg 2011a).

Archeobotanists have focused their energies upon honing their methods toward the effective recovery of and identification of residual starch granules to understand plant use and processing. Studies have resulted in an impressive assemblage of various suites of starchy food plants, both wild and domesticated, raw and cooked. At this juncture in time, more studies are being undertaken and starch remains are being successfully recovered. What we now lack are baseline data as to how and why

different plant materials may or may not adhere to stone tools. Thus, we are not yet able to understand issues such as intensity of use based upon numbers of recovered grains, or the history of a tool based upon the numbers of species of plants recovered from its surface. Linda Perry has obtained funding and will be performing experiments over the next year in the hopes of gaining an understanding of these issues.

## D.2 METHODS

Sixty samples from three sites were selected for analysis. These samples included 35 burned rocks of both sandstone and limestone, three manos or metate fragments, 17 flaked tools, and five sediment samples. All artifacts with the exception of the majority of the flaked stone tools were collected and bagged separately without washing. Washing is a traditional step in the collection and curation of artifacts, but it will remove some of the residues that are of interest to archeologists.

All artifacts were placed in clean, metal beakers and were covered with filtered water. The beakers were then set aside for ten minutes to soak in the hope that this step would loosen the microfossils and allow for a better extraction. At this point, the beakers were placed in a sonic bath for ten minutes to shake the microfossils loose from the artifacts. The artifacts were removed from the beakers and the surfaces were rinsed with filtered water that was collected in the same effluent vessel.

The effluent from the cleaning was allowed to settle overnight, then the settled material was centrifuged for ten minutes at 1,000 RPM to pellet out the solids. The solid materials were then subject to a heavy liquid flotation using cesium chloride (CsCl) at a density of 1.8 g/cm<sup>3</sup> to separate the starch grains from the sediment matrix.

Sediment samples were deflocculated with a combination of baking soda and deionized water for a period of three days. The samples were then centrifuged and the baking soda/water was

discarded. The sediments were then subjected to a heavy liquid flotation, after which the steps are identical to those used in artifact processing.

The material collected from the flotation was rinsed and centrifuged three times with filtered water to ensure that the CsCl was completely removed from the solution. At this point, the pellet from the final centrifugation was placed on a clean glass slide with a small amount of water/glycerin solution.

Slides were scanned with a Zeiss Universal compound microscope for polarized light at 200×, and identifications were made at 400× using standard methods. Digital images were captured at 800× magnification using a Micropublisher 3.3 camera and software.

### **D.3 RESULTS**

A total of 24 intact starch grains was recovered from the samples (Table D-1). Seven of these are lenticular in morphology, 5 are from maize, 1 is probably from maize, 5 are from as yet unidentified grasses, and another 6 are unidentifiable (Figure D-1). Damage derived from processing including heating, heating in the presence of water, and grinding was also observed.

#### **D.3.1 Site 41LM49**

Six artifacts were analyzed from site 41LM49: three sandstone burned rocks, two limestone burned rocks, and one mano (#2-11), all from Feature 1. Two of the sandstone burned rocks yielded starch remains. Burned rock #1-3-8a yielded a single, unidentified starch, and burned rock #1-3-9a contained two lenticular grains.

#### **D.3.2 Site 41LM50**

Twenty-eight artifacts from site 41LM50 were analyzed: eight limestone burned rocks, nine sandstone burned rocks, one with a modified-edge, ten flaked tools, and a single, burned mano. Eight

artifacts yielded identifiable starch remains, and one contained damaged but unidentifiable starch.

#### ***Feature 1***

Seven burned rocks from Feature 1 were analyzed. Two limestone burned rocks yielded single starch grains from maize (#70-3-5) and probably from maize (#70-3-4). A single sandstone burned rock from Feature 1 contained a grass starch grain, and also starch apparently damaged by heating, although the specific type of heating is not determinable from the evidence.

#### ***Feature 2***

Eleven artifacts from Feature 2 were analyzed. Two sandstone burned rocks #71-3-1 and #71-3-3 yielded gelatinized starch grains indicating heating in the presence of water. One of these rocks (#71-3-3) also contained a single starch grain derived from an unidentified grass.

#### ***Non-Feature Contexts***

Five artifacts from non-feature contexts yielded starch remains. An edge-modified sandstone (#2-10) piece contained two lenticular starch grains, a starch grain from an unidentified grass, and evidence of gelatinization, or heating in the presence of water. A burned artifact believed to be a metate fragment (#27-10) yielded gelatinized starch, again, indicating heating in the presence of water.

Three edge-modified flaked tools yielded starch grains. One (#12-10) had a single lenticular starch grain, another (#35-11) contained a single grain from maize, and a third (#35-10) yielded a single grain that is unidentifiable.

#### **D.3.3 Site 41LM51**

Twenty-six samples from site 41LM51 were analyzed for starch remains. These artifacts included thirteen burned rocks, one mano, seven flaked tools, and five sediment samples, three of which were collected in feature contexts, and two

that were collected from noncultural contexts for control purposes.

### **Feature 3**

Two limestone burned rocks from Feature 3 yielded starch remains. One rock (#103-3-1) yielded a single grain derived from an unidentified grass. Another rock (#103-3-3) contained a starch grain from maize as well as evidence of heating in the presence of water.

### **Feature 4**

A single limestone burned rock from Feature 4 (#104-3-2) yielded one starch grain from an unidentified plant source.

### **Non-Feature Contexts**

A single, limestone burned rock (#3-3-1) from a non-feature context yielded a single lenticular starch grain. Four flaked tools yielded starch grains. A biface midsection (#59-10) contained a lenticular starch grain, a starch grain from maize, as well as indications of heating and grinding damage. Another biface fragment (#81-10) yielded a starch grain from maize as well as one from an unidentified plant source. A third biface fragment (#91-10) contained a starch grain from an unidentified grass as well as evidence of heating in the presence of water. An edge-modified flaked tool (#91-12) contained gelatinized starch, evidence of heating in the presence of water.

### **Sediment Samples**

None of the sediment samples from noncultural contexts yielded starch grains. A single sample from Feature 4 (#104-4-b) yielded one starch grain from an unidentified source. Notably, this starch grain is not of the morphology of any other in the entire assemblage, thus indicating a unique origin and a lack of relation to the remaining assemblage.

### **D.3.4 Starch Analysis of Artifacts Subjected to Use-Wear Analysis**

A single starch grain was recovered from one of the seven artifacts that were studied for use-wear patterns (41LM50, #12-10). Fragments of woody tissues that include pitting that will create extinction cross-type light effects under cross-polarized light were also observed. A scraper (41LM50, #26-10) yielded vessel elements typical of oak wood. A biface (41LM50, #54-10) contained tracheary elements with circular-bordered pits. Both residues may indicate either hafting materials or wood processing with these tools.

## **D.4 DISCUSSION AND CONCLUSIONS**

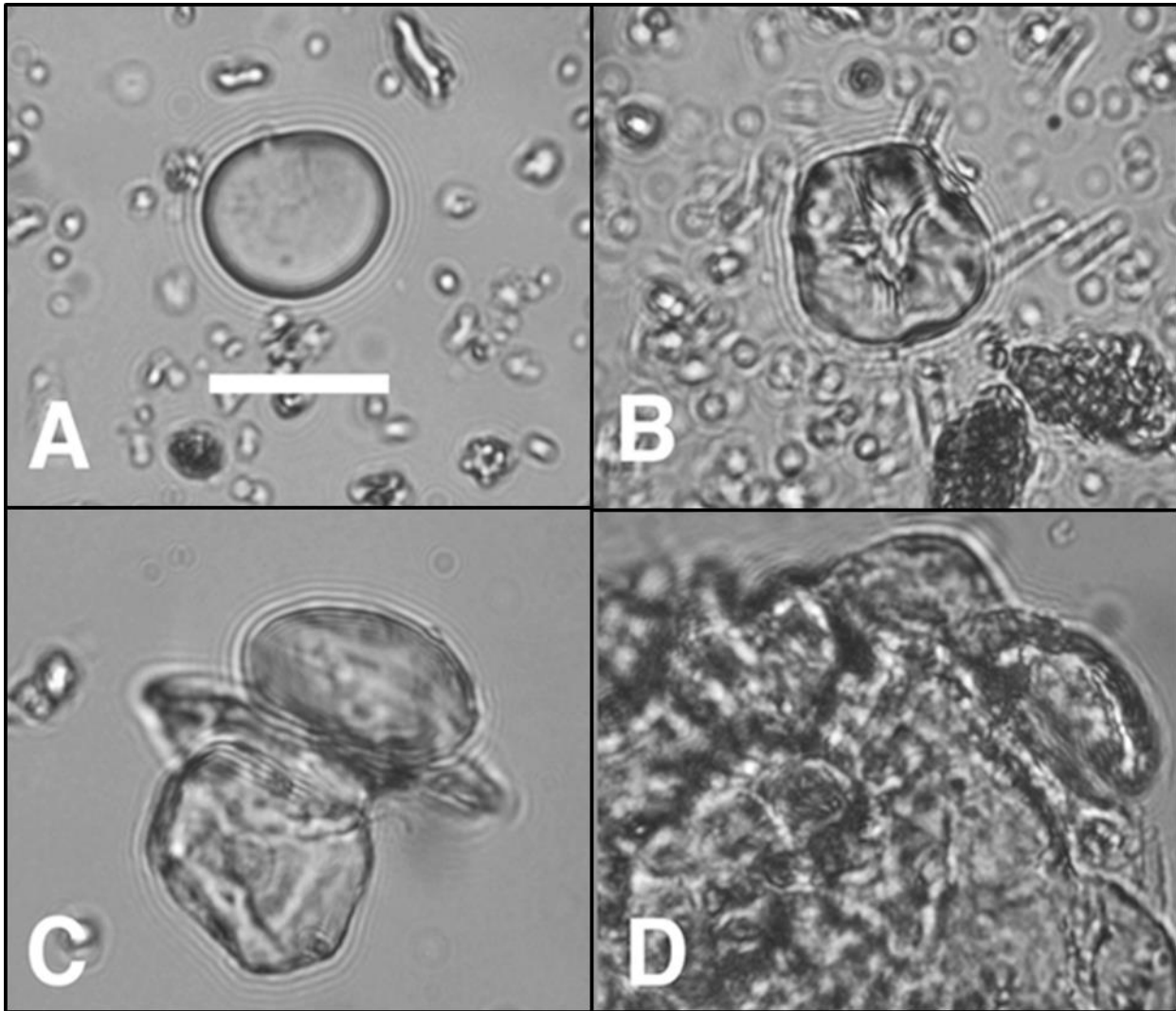
### **D.4.1 Damaged Starch Grains**

Gelatinized starch grains, those that have been heated in the presence of water, were recovered from eight artifacts including four burned rocks. The presence of this type of damage on the burned rocks is a good indicator that stone boiling was occurring on site as a means of cooking plant foods.

Heating damage ( $N = 2$ ) was also present (burned rock #70-3-2 from 41LM50 and biface fragment #59-10 from 41LM51), but the evidence did not clearly indicate the type of heating, be it parching or boiling. Grinding damage occurred in a single sample (#59-10 from 41LM51) on a single grain of maize. It is not known if the grinding, or processing into a meal or flour, occurred onsite or elsewhere.

### **D.4.2 Identifications and Plant Use at the Sites**

Lenticular starch grains ( $N = 7$ ) are derived from plants in the grass tribe Triticeae, and may be from wildrye (*Elymus* spp.) or little barley (*Hordeum pusillum*). Unfortunately, the assemblage of lenticular starch grains from these three sites did not contain any that were diagnostic of either plant group, therefore, the identifications remain at the level of tribe.



**Figure D-1. Starch remains recovered from the analyzed samples.**

**Note:** The scale bar is 20 microns in length, and all photographs are at equivalent magnification.  
A is a lenticular starch grain from a sandstone burned rock 41LM49, #1-3-9a.  
B is a maize starch grain from a limestone burned rock 41LM51, #03-3-3.  
C is a maize starch grain adhering to what may be a lenticular starch grain that has been distorted by heat. The center of this maize starch has a clean scoop out of it, an indication of processing by grinding. From biface midsection 41LM51, #59-10.  
D is the edge of a large clump of gelatinized starches that appear to have been lenticular in their native state from sandstone burned rock 41LM50, #71-3-3.

Maize starch grains (*Zea mays*) do not occur in the assemblage from 41LM49, but are present ( $N = 5$ ) at the other two sites. The maize assemblage includes starch grains that are typical of the diagnostic forms we find in modern maize samples (identified as "maize") as well as a grain that is probably maize, but is not diagnostic enough for a secure identification. It is quite likely that the majority of starches identified as "grass" grains in the assemblage are from this maize assemblage, but, again, issues of small numbers and preservation prevent secure identifications.

It should be noted that the major prairie grasses from the Panicoid group (that which includes maize) have been studied and it has been determined that the starches in this prehistoric assemblage are not derived from big bluestem (*Andropogon gerardii*), little bluestem (*Schizachyrium scoparium*), canarygrass (*Phalaris caroliniana*), various crabgrasses (*Digitaria* spp.), bristlegrasses (*Setaria* spp.) and panic grasses (*Panicum* spp.). At this point in time, there is no

other explanation for the occurrence of these starches than the presence of maize, and probably maize flour or meal, at the site.

Gelatinized starches ( $N = 8$ ) occur on artifacts that yielded starch grains from both the Triticeae and maize. Thus, it appears that both types of grain were being cooked at the two sites, possibly via stone boiling. Two flaked stone biface fragments (#81-10 and #59-10) from the Late Archaic component at 41LM51 yielded remains of both lenticular and maize starches that are fused together, most probably by heating, thus indicating the possible cooking of these grains together (Figure D-1). Whether or not this is an indication of deliberate combination of the plants cannot be determined.

Ubiquity indices of lenticular and maize-derived starches at sites 41LM50 and 41LM51 are roughly equivalent. This pattern may indicate relatively equal importance of these two types of plant foods at both sites.

## D.5 REFERENCES CITED

- Atchison, J. and R. Fullagar,  
1998 Starch residues on pounding implements from Jinmium rock-shelter. In *A Closer Look: Recent Studies of Australian Stone Tools*, edited by R. Fullagar. Sydney University Archaeological Methods Series 6, Archaeological Computing Laboratory, School of Archaeology, University of Sydney, Sydney.
- Babot, M. del Pilar  
2003 Starch grain damage as an indicator of food processing. In *Phytolith and Starch Research in the Australian-Pacific-Asian Regions: The State of the Art*, edited by D. M. Hart and L. A. Wallis, pp. 69-81. Papers from a conference held at the ANU, August 2001, Canberra, Australia. Pandanus Books.
- Babot, M. del Pilar and M. C. Apella  
2003 Maize and bone: residues of grinding in northwestern Argentina. *Archaeometry* 45:121-132.
- Barton, H., R. Torrence, and R. Fullagar.  
1998 Clues to Stone Tool Function Re-examined: Comparing Starch Grain Frequencies on Used and Unused Obsidian Artefacts. *Journal of Archaeological Science* 25:1231-1238.
- Briuer, F. L.  
1976 New Clues to Stone Tool Function: Plant and Animal Residues. *American Antiquity* 41(4):478-484.
- Bryant, V. M.  
2003 Invisible clues to new world plant domestication. *Science* 299:1029-1030.
- Coil, J., M. A. Korstanje, S. Archer, and C. A. Hastorf  
2003 Laboratory goals and considerations for multiple microfossil extraction in archaeology. *Journal of Archaeological Science* 30:991-1008.
- Crawford, G. W. and D. G. Smith  
2003 Paleoethnobotany in the Northeast. In *People and Plants in Ancient Eastern North America*, edited by P. E. Minnis, pp. 172-257. Smithsonian Books, Washington DC.
- Denniston, R. H.  
1904 The Growth and Organization of the Starch Grain. Unpublished Ph.D. dissertation. University of Wisconsin, Madison, Wisconsin.
- Fullagar, R., T. Loy, and S. Cox,  
1998 Starch grains, sediments and stone tool function: evidence from Bitokara, Papua New Guinea. In *A Closer Look: Recent Australian Studies of Stone Tools*, edited by R. Fullagar, pp. 49-58. Archaeological Computing Laboratory, University of Sydney.
- Green W. and C. Tolmie  
2004 Analysis of Plant Remains from Blood Run. *Plains Anthropologist* 49(192):525-542.
- Hall, J., S. Higgins, and R. Fullagar  
1989 Plant Residues on Stone Tools. *Tempus* 1:136-155.
- Haslam, M.  
2003 Evidence for maize processing on 2000 year old obsidian artefacts from Copán, Honduras. In *Phytolith and Starch Research in the Australian-Pacific-Asian Regions: The State of the Art*. D. edited by

- M. Hart and L. A. Wallis, pp. 153-161. Papers from a conference held at the ANU, August 2001, Canberra, Australia. Pandanus Books.
- 2004 The decomposition of starch grains in soils: implications for archaeological residue analyses. *Journal of Archaeological Science* 31:1715-1734.
- Henry A. G., H. F. Hudson, and D. R. Piperno.
- 2009 Changes in starch grain morphologies from cooking. *Journal of Archaeological Science* 36:915-922.
- Iriarté, J., I. Holst, O. Marozzi, C. Listopad, E. Alonso, A. Rinderknecht, and J. Montaña
- 2004 Evidence for cultivar adoption and emerging complexity during the mid-Holocene in the La Plata basin. *Nature* 432:614-617.
- Loendorf, L. L.
- 1985 A Possible Explanation for the Association between Wild Rye Grass (*Elymus* spp.) and Formerly Occupied Cave Sites in the Pryor Mountains, Montana. *Plains Anthropologist* 30(108):137-144.
- Loy, T. H.
- 1994 Methods in the Analysis of Starch Residues on Prehistoric Stone Tools. In *Tropical Archaeobotany: Applications and New Developments*, edited by J. G. Hather, pp. 86-113. Routledge.
- Loy, T. H., M. Spriggs, and S. Wickler
- 1992 Direct evidence for human use of plants 28,000 years ago: starch residues on stone artifacts from the northern Solomon Islands. *Antiquity* 66:898-912.
- MacMasters, M. M.
- 1964 Microscopic Techniques for Determining Starch Granule Properties. In *Methods in Carbohydrate Chemistry*, edited by R. L. Whistler, pp. 233-240. Academic Press.
- Pearsall, D. M., K. Chandler-Ezell, and J. A. Zeidler
- 2004 Maize in ancient Ecuador: results of residue analysis of stone tools from the Real Alto site. *Journal of Archaeological Science* 31:423-442.
- Perry, L.
- 2001 Prehispanic subsistence in the middle Orinoco basin: starch analyses yield new evidence. Unpublished Doctoral dissertation, Southern Illinois University Carbondale, Illinois.
- 2002 Starch analyses indicate multiple functions of quartz "manioc" grater flakes from the Orinoco basin, Venezuela. *Interciencia* 27(11):635-639.
- 2004 Starch analyses reveal the relationship between tool type and function: an example from the Orinoco valley of Venezuela. *Journal of Archaeological Science* 31(8):1069-1081.
- 2005 Reassessing the traditional interpretation of "manioc" artifacts in the Orinoco valley of Venezuela. *Latin American Antiquity*.
- 2007 Starch grains, preservation biases, and plant histories. In *Rethinking Agriculture: Archaeological and Ethnographic Perspectives*, edited by T. Denham, L. Vrydaghs and J. Iriarté. One World Archaeology, Left Coast Press.
- 2010 Starch Analyses from the BLM Landis Property. In *Landis Property: Data*

- Recovery at Three Prehistoric Sites (41PT185, 41PT186, and 41PT245) in Potter County, Texas*, by J. Michael Quigg, Charles D. Frederick, Paul M. Matchen, and Kendra G. DeBois, pp. 767-785. TRC Technical Report 150832, TRC Environmental Corporation, Austin.
- Perry L. and J. M. Quigg  
2011a Starch remains and stone boiling in the Texas panhandle part 1: The Pipeline, Corral, and Pavilion sites. *Plains Anthropologist* 56:95-108.
- 2011b Starch remains and stone boiling in the Texas panhandle part 2: Identifying wildrye (*Elymus* spp.). *Plains Anthropologist* 56:109-120.
- Perry, L., D. Sandweiss, D. Piperno, K. Rademaker, M. Malpass, A. Umire, and P. de la Vera.  
2006 Early Maize Agriculture and Interzonal Interaction in Southern Peru. *Nature* 440:76-79.
- Perry, L. R. Dickau, S. Zarrillo, I. Holst, D. Pearsall, D. Piperno, M. Berman, R. Cooke, K. Rademaker, A. Ranere, J. Raymond, D. Sandweiss, F. Scaramelli, K. Tarble, and J. Zeidler.
- 2007 Starch fossils and the domestication and dispersal of chili peppers (*Capsicum* spp. L.) in the Americas. *Science* 315:986-988. With accompanying Perspective, S. Knapp. Some Like it Hot. *Science* 315:946-947.
- Piperno, D. R. and I. Holst  
1998 The presence of starch grains on prehistoric stone tools from the humid Neotropics: indications of early tuber use and agriculture in Panama. *Journal of Archaeological Science* 25:765-776.
- Piperno, D. R., A. J. Ranere, I. Holst, and P. Hansell  
2000 Starch grains reveal early root crop horticulture in the Panamanian tropical forest. *Nature* 407: 894-897.
- Ranere, A. J.  
1975 Tool making and tool use among the preceramic peoples of Panama. *Lithic Technology*, pp. 173-210, Mouton.
- Reichert, E. T.  
1913 The Differentiation and Specificity of Starches in Relation to Genera, Species, Etc. In two parts. Carnegie Institution of Washington.



**Table D-1. Starch Remains Recovered from the Analyzed Samples.**

Site	Pnum	Feature	Artifact Type	Lenticular	Maize	Cf. Maize	Grass	UK	Damage	Total
41LM49	1-3-2	1	L B Rock							0
41LM49	1-3-3	1	L B Rock							0
41LM49	1-3-4	1	SS B Rock							0
41LM49	1-3-8a	1	SS B Rock					1		1
41LM49	1-3-9a	1	SS B Rock	2						2
41LM49	211	1	Mano							0
41LM50	68-3-1	1	L B Rock							0
41LM50	69-3-2	1	SS B Rock							0
41LM50	70-3-1	1	L B Rock							0
41LM50	70-3-2	1	SS B Rock				1		H	1
41LM50	70-3-3	1	SS B Rock							0
41LM50	70-3-4	1	L B Rock			1				1
41LM50	70-3-5	1	L B Rock		1					1
41LM50	71-3-5a	2	L B Rock							0
41LM50	71-3-6a	2	SS B Rock							0
41LM50	71-3-7a	2	L B Rock							0
41LM50	71-3-9	2	L B Rock							0
41LM50	71-3-1	2	SS B Rock					1	Gl	X
41LM50	71-3-2	2	SS B Rock							0
41LM50	71-3-3	2	SS B Rock				1		Gl	1
41LM50	71-3-4	2	L B Rock							0
41LM50	71-3-6	2	SS B Rock							0
41LM50	71-11	2	Edge mod							0
41LM50	71-14	2	Edge mod							0
41LM50	1-11		Edge mod							0
41LM50	2-10		Edge Mod SS	2			1		Gl	3

Site	Pnum	Feature	Artifact Type	Lenticular	Maize	Cf. Maize	Grass	UK	Damage	Total
41LM50	12-10		Edge mod Fl	1						1
41LM50	18-11		Uniface							0
41LM50	25-10		Edge mod Fl							0
41LM50	26-10		Scraper							0
41LM50	27-10		Metate / Burn						Gl	X
41LM50	35-10		Edge mod					1		1
41LM50	35-11		Edge mod		1					1
41LM50	54-10		Biface							0
41LM51	102-3-1	2	L B Rock						Gl	X
41LM51	102-3-2	2	L B Rock							0
41LM51	102-3-3	2	L B Rock							0
41LM51	102-3-4	2	L B Rock							0
41LM51	103-3-1	3	L B Rock				1			1
41LM51	103-3-2	3	L B Rock							0
41LM51	103-3-3	3	L B Rock		1				Gl	1
41LM51	103-3-4	3	L B Rock							0
41LM51	103-10	3	Edge Mod							0
41LM51	104-3-2	4	L B Rock					1		1
41LM51	104-3-4	4	L B Rock							0
41LM51	104-3-5	4	L B Rock							0
41LM51	104-3-6	4	L B Rock							0
41LM51	3-3-1		L B Rock	1						1
41LM51	59-10		Biface Mid	1	1				H, GD	2
41LM51	59-11		Mano							0
41LM51	66-10		Side Scraper							0
41LM51	81-10		Biface Frag		1			1		2
41LM51	83-10		Biface							0
41LM51	91-10		Biface Frag				1		Gl	1

Site	Pnum	Feature	Artifact Type	Lenticular	Maize	Cf. Maize	Grass	UK	Damage	Total
41LM51	91-12		Edge Mod						GI	X
41LM51	102-4-b	2	Sediment							0
41LM51	103-4-b	3	Sediment							0
41LM51	104-4-b	4	Sediment					1		1
41LM51	117-4-b		Sed Control							0
41LM51	130-4-a		Sed Control							0
Total				7	5	1	5	6	X	24

"GI" indicates gelatinization. "H" indicates damage from an unknown source of heat.

"GD" indicates grinding damage.

## **APPENDIX E**

# **ASSESSMENT OF PHYTOLITH PRESERVATION AT 41LM51**

Prepared for:



TRC Environmental Corporation  
505 East Huntland Drive, Suite 250  
Austin, Texas 78752

Prepared by:

Steven Bozarth, Ph.D.  
Palynologist and Opal Phytolith Analyst  
2004 New Hampshire Street  
Lawrence, Kansas 66046

November 2004

*This page intentionally left blank.*

## ASSESSMENT OF PHYTOLITH PRESERVATION AT 41LM51

Steven Bozarth, Ph.D.

The following sediment samples were processed for phytoliths: Unit 2, 23-25 cmbs, #104-4a; Unit 2, 86-88 cmbs, #117-4a; Unit 5, 10-12 cmbs, #125-4a; Unit 5, 59-61 cmbs, #132-4a; Trench 1, Zone 10, 160-169 cmbs, #174-4a; and near head of drainage - up slope, #178-4a (Table E-1).

Phytoliths were isolated from 5-gram samples using a procedure based on heavy-liquid (zinc bromide) flotation and centrifugation. This procedure consists of five basic steps: 1) removal of carbonates with dilute hydrochloric acid; 2) removal of colloidal organics, clays, and very fine silts by deflocculation with sodium pyrophosphate, centrifugation, and decantation through a 7- $\mu$  filter; 3) oxidation of sample to remove organics; 4) heavy-liquid flotation of phytoliths from the heavier clastic mineral fraction using zinc bromide concentrated to a specific gravity of 2.3; 5) washing and dehydration of phytoliths with butanol; and 6) dry storage in 1-dram vials.

A representative portion of each phytolith isolate was mounted on a microscope slide in immersion oil under a 22x40 mm cover glass and sealed with clear nail lacquer. Each slide was then scanned with a petrographic Zeiss microscope at a magnification of 625X.

Phytoliths were well-preserved in all samples except Trench 1, in which the phytolith concentration was very low, evidently the result of poor preservation. C<sub>3</sub> and C<sub>4</sub> grass phytoliths were found in the five samples with good preservation. Phytolith analysis of these five samples would provide interpretable paleoenvironmental data at 41LM51.

**Table E-1. Samples Used in Phytolith Analysis.**

Cat. No.	Unit	Depth	Comments
104-4a	2	23-25	lower terrace
117-4a	2	86-88	lower terrace
125-4a	5	10-12	upper terrace
132-4a	5	59-61	upper terrace
174-4a	BT 1	160-169	Zone 10
178-4a	surface	0-2	head of draw

*This page intentionally left blank.*

## **APPENDIX F**

# **ENVIRONMENTAL BIOSILICA DATA 41LM50 AND 41LM51: EARLY ARCHAIC THROUGH LATE PREHISTORIC PERIODS**

Prepared for:



TRC Environmental Corporation  
505 East Huntland Drive, Suite 250  
Austin, Texas 78752

Prepared by:

J. Byron Sudbury  
J. S. Enterprises, Inc.  
Ponca City, Oklahoma  
([jschemistry@hotmail.com](mailto:jschemistry@hotmail.com))

August 2013



*This page intentionally left blank.*

## **ENVIRONMENTAL BIOSILICA DATA 41LM50 AND 41LM51: EARLY ARCHAIC THROUGH LATE PREHISTORIC PERIODS**

J. Byron Sudbury, Ph.D.

### **F.1 SUMMARY**

Ten soil samples from two Lampasas County Texas sites were processed for biogenic silica evaluation to provide data enabling Holocene environmental interpretation. Recovered proxies included phytoliths, sponge spicules, charred particles, and charcoal.

### **F.2 OVERVIEW**

Phytoliths originate from plants and represent the predominant microfossil type recovered from most soils. When a living plant absorbs soil water, dissolved silica enters the plant's vascular system. As water is used via plant metabolism or lost via transpiration, the dissolved silica becomes supersaturated and precipitates out as amorphous siliceous deposits ( $\text{SiO}_2 \cdot n\text{H}_2\text{O}$ ). These deposits often mirror the form of the cell or intracellular space that the silica occupied. When plants later undergo senescence, the organic material decomposes, but the inorganic siliceous "phytoliths" are incorporated into the soil--predominantly in the silt fraction (i.e., a particle size range of 2-50 microns). Larger and smaller phytoliths do occur, but those of greatest utility for environmental interpretation, "short cells", are components of the silt fraction. The so-called "short cell" phytoliths occur in plant leaves. The short cells of the species of several major grass subfamilies generally have distinctive short cell phytolith morphologic signatures. The three grass subfamilies of prime environmental interest are the Pooids (cool, moist season grasses [i.e., predominantly spring and fall growth seasons]), the Panicoids (warm season, intermediate moisture grasses), and Chloridoids (hot dry season grasses),

both of the latter mature during the course of the summer and early fall.

### **F.3 BACKGROUND**

These two sites are along Lynch Creek, a small tributary creek of the Colorado River which seldom floods as described in the Environmental Background section. The soils are predominantly comprised of Weswood<sup>2</sup> and Roughcreek<sup>3</sup>-Rock outcrop complex soils.

The Weswood series (fine-silty, mixed, superactive, thermic udifluventic Haplustepts) "consists of very deep, well drained, moderately permeable soils that formed in calcareous loamy alluvium", and "are on nearly level to moderately sloping flood plains. Slopes are mainly less than 1 percent, but range up to 8 percent." The Roughcreek series (clayey-skeletal, smectitic, thermic lithic Argiustolls) "consists of soils that are shallow to indurated limestone bedrock of Ordovician age. These well drained soils formed in residuum derived from weathering of dolomitic limestone. These gently sloping to steep soils [1-40 percent slope] are on summits, shoulders, and backslopes of ridges on dissected plateaus."

The descriptions of the soil samples analyzed are summarized in Table F-1.

### **F.4 LABORATORY PHYTOLITH RECOVERY PROCEDURE**

The basic procedure for quantitative phytolith recovery is relatively simple but very labor intensive. In short, the dried soil samples are deflocculated in detergent, separated into size fractions via settling parameters based on Stokes Law, and the less dense phytoliths and other biogenic silica particles are "floated" away from the quartz-based silt matrix by using a heavy liquid (in this case zinc bromide solution at 2.35 g/cm<sup>3</sup>). By mixing the silt fraction with the heavy liquid solution, the denser quartz-based silt particles (~2.65g/cm<sup>3</sup>) remain on the bottom and the less

**Table F-1. Lampasas County Site's Soil Samples Identities.**

Site No.	PNUM	Unit	Depth (cmbs)	Feature	Comments	Lab Sample Numbers
41LM51	102-004	9	80-90	2	under F2	1
	103-004	10	42-47	3	under F3	2
	104-004	10	45-55	4	under F4	3
	108-004	2	23-25	NA	environment	4
	117-004	2	86-88	NA	environment	5
	132-004	5	59-61	NA	environment	6
	157-004	9	surface	NA	modern control	7
41LM50	41-004	6	18	NA	buried control	8
	69-004	2	23	1	under F1	9
	71-004	BT-2	15	2	under F2	10

dense biogenic silica particles (which includes phytoliths, sponge spicules, diatoms--all made of SiO<sub>2</sub>--as well as some low density mineral contaminants) with a density ranging from ~1.60-2.30 g/cm<sup>3</sup> float to the surface of the heavy liquid where they can be quantitatively collected for examination.

The basic laboratory procedure has been developed and refined by numerous individuals over the decades, being most recently summarized in the valuable tomes of Piperno (2006) and Pearsall (2000). This current researcher's subsequent work introduced a number of significant changes and method improvements as described and illustrated elsewhere (c.f. Sudbury 2009, 2011a, 2011b, 2011c, 2013). This detailed method information will not be repeated here. However, each set of soil samples poses its own unique challenges and eccentricities, and new issues encountered in this sample suite will be briefly addressed in this processing section.

The soil samples were dried, weighed, and photographed to document sample color (Figure F-1).

Calgon® solution was added to the samples which were then placed on an Eberbach® shaker, vigorously shaken for 24 hours (Figure F-2), and

then allowed to settle. Figure F-3 shows the variation in the color of the suspended clay fractions (with some fine silt included). When Calgon® was added to the samples, sample 7 (the modern control sample, 157-004) was difficult and slow to "wet"; the same sample also foamed much more than any other samples (see Figures F-2 [middle column, second from top] and Figure F-3). Sample 41-004 foamed somewhat--but not nearly as much as 157-004.

After the proper settling time for the sand to settle out of suspension, 80 percent of the upper phase of the solution above each sand (Figure F-4) was decanted away from the samples. Fresh deionized water was added, the samples remixed, and again decanted; this series of steps was repeated until the upper liquid phase was clear leaving clean sand behind. The decants for each sample--containing a mixture of silt and clay were saved for further processing (Figure F-6).

The lower portion of the settled control samples from immediately above the bottom tan layer of sand (#7, 157-004). Note the dark near black layer of about the same thickness as the lower sand layer; this is organic debris from the surface control sample. The upper black layer in the buried control sample 41-004 (#8) is much thinner.

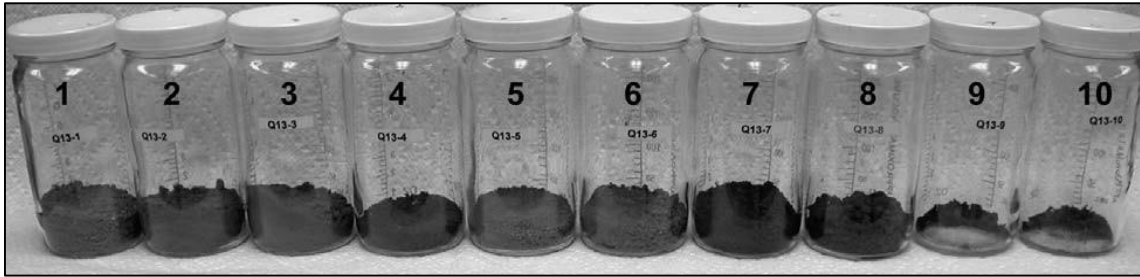


Figure F-1. Soil samples prior to detergent addition and disaggregation to separate particle sizes. The lab sample number abbreviations of #1-10 are identified in Table F-1 (right hand column).



Figure F-2. Samples in Calgon® solution on mechanical reciprocal shaker which was set at 180 strokes/- minute. The samples were shaken vigorously for 24 hours. The two empty jars in the upper right corner served as spacers (2-27-13).

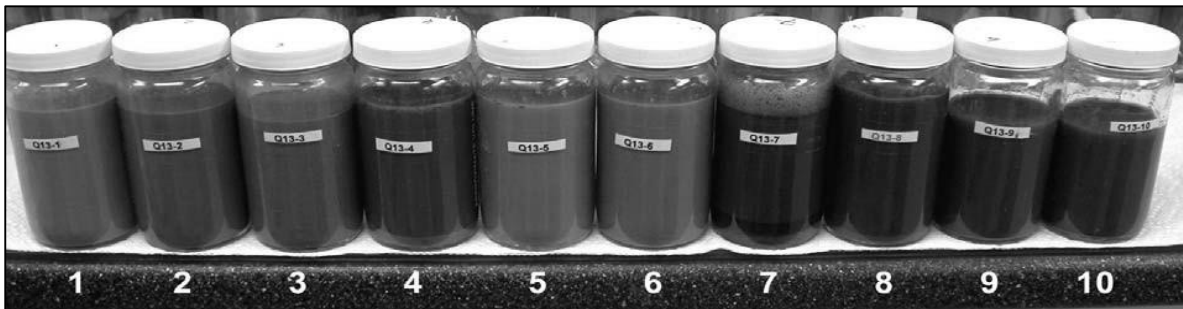


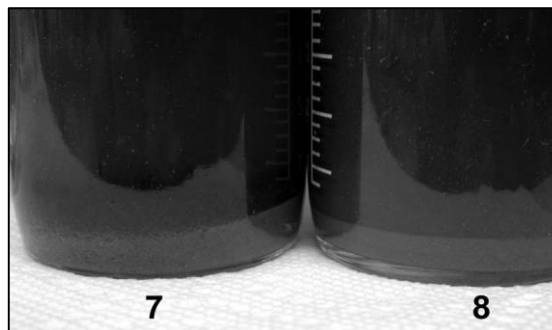
Figure F-3. Disaggregated sample solutions upon removal from the mechanical shaker. The clay (and some silt) is still suspended while the sand fractions have already settled.

The clay did not completely settle out of the pooled decant solutions shown in Figure F-5 B for all samples. Most samples ended up with an inch or two of fluffy material above the layer of settled silt. After removal of the upper relatively clean portion of each solution, the entire lower phase (silt and partially settled clay) was transferred to smaller bottles, settled for 8 hours, and the upper ~60 percent of the suspended clay removed until the upper portion of the solution was clear. Then, after the final mixing and settling, the clay layer down to immediately above the silt layer was removed by pipette; the remaining silt was then washed (mixed, settled, and any clay then decanted after settling) a dozen times for final cleaning.

Partially settled clay was transferred to smaller bottles, settled for 8 hours, and the upper ~60 percent of the suspended clay removed until the upper portion of the solution was clear. Then, after the final mixing and settling, the clay layer down to immediately above the silt layer was removed by pipette; the remaining silt was then washed (mixed, settled, and any clay then decanted after settling) a dozen times for final cleaning.

- A. Illustrates samples immediately after the decants were performed.
- B. Illustrates the same decanted sample solutions after settling for 72 hours. Four months later, the clay fraction in sample 8 (41-004) still had not completely settled and that solution was still opaque.

The isolated clay fractions contained particles generally 2 microns and smaller in diameter as expected--with the exception of some long rod-like crystals (Figure F-6). These high surface areas of these crystals may delay their settling; if entangled, they could be the cause of the slow clay precipitation (the clay fraction partially settled, but never completely settled). No distinct phytoliths by-product resulting from the limestone and rock



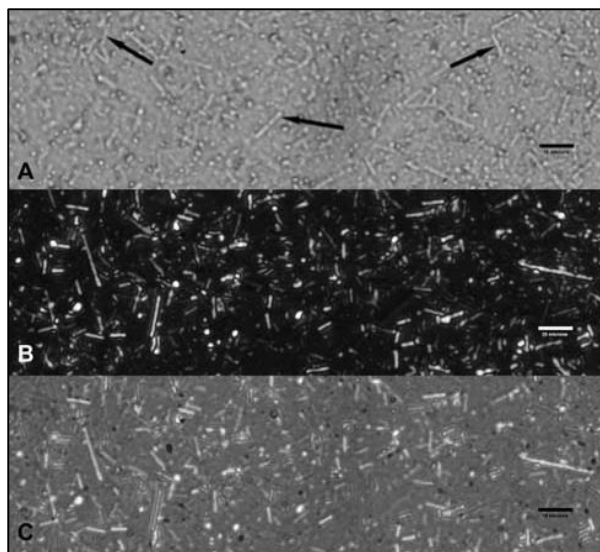
**Figure F-4. The lower portion of the two settled control samples (157-004 and 41-004).**



**Figure F-5. Decanted sample solutions containing silt and clay after decanting from the sand fraction.**

in the soil profile, were prevalent in the 41LM51 samples but absent from the 41LM50 clay fractions.

Three different illuminations of the same microscopic field are shown (500x). The small white spheres in A are normal clay particles ( $\sim \leq 2$  microns). The three arrows in image A show three example cylindrical crystals or fiber-type particles that are visible in A, but not visible in B or C. That is because these particular fibers in A are oriented at what is known as their extinction angle at which they are not visible via crossed polars. Image A was taken while illuminated with plane polarized light, image B was taken while viewed with crossed polars, and image C was taken while illuminated



**Figure F-6. The suspended clay fraction from Sample 6 in Figure F-5A.**

with crossed polars with a quarter wave plate in place. The various colors in B and reflect the crystalline nature of the particles; phytoliths are amorphous particles (i.e., they are non-crystalline). No silt size phytoliths are visible in these clay images. The scale bars at the right indicate 10 microns.

Even though many rod-like crystals were removed with the suspended clay fraction the resulting settled silt fractions shown in Figure F-7 appear to show related contamination. The samples from 41LM51 have a unique upper white zone--most distinctly visible in sample 2. This white zone, present in samples 1-6 (i.e., 41LM51) is due to low density and/or large surface area mineral particles (thus, the material settled on top of the denser quartz-based portion of the silt fraction which settled faster). Initially, I wondered if the upper whitish layer may be ash, but the images in Figure F-6 implicated soil mineral contamination. This observation indicates several processing issues affecting the sample data. These would include inaccuracies in the actual amount of silt detected, as well as an inaccurate weight for the phytolith soil concentration (as the minerals could potentially

contaminate the phytolith fraction). The mineral present is presumably due to the peculiar limestone-origin of the soil (carbonate compounds? and cations), the basic soil pH, and the site's overall soil chemistry.

These sample bottles are about 2 inches in diameter. Sample 7 is the modern control sample (157-004), sample 8 is the buried control sample (41-004), and samples 9-10 are from 41LM50. Silt samples 1-6 from 41LM51 exhibit an upper white zone suggesting additional soil mineral contamination. In some cases, the white contaminant zone appears to comprise as much as 50 percent of the silt fraction by volume.

This acid pretreatment was performed by adding 10 percent hydrochloric acid to the isolated silt fractions (Figure F-7), the silt allowed to settle, the liquor decanted, and more acid added to the silt until more effervescence upon acid addition did not occur. Then the silts were repeatedly rinsed with deionized water until the solution pH from the excess acid was neutralized.

The "cleaned" silts were then dried, weighed, transferred to crucibles, and thermally ashed to remove organic material. The ashed silt fractions were transferred to 50 ml test tubes, zinc bromide solution added, and the samples mixed on a vortex stirrer multiple times until the light fraction separated (floated). The phytoliths were harvested, and floating repeated until no more phytoliths were released from the silt. The isolated phytolith fractions were then thoroughly water washed to remove the zinc bromide, and dried (Figure F-8). Next, the phytolith residues were homogenized, aliquots from each sample placed on microscope slides, mounted in Canada Balsam for particle counting, the slides thermally cured, and particle counts performed with particle rolling performed as required by the particles. Although some mineral contamination was present on the phytolith slides, none of the crystalline rods were observed.

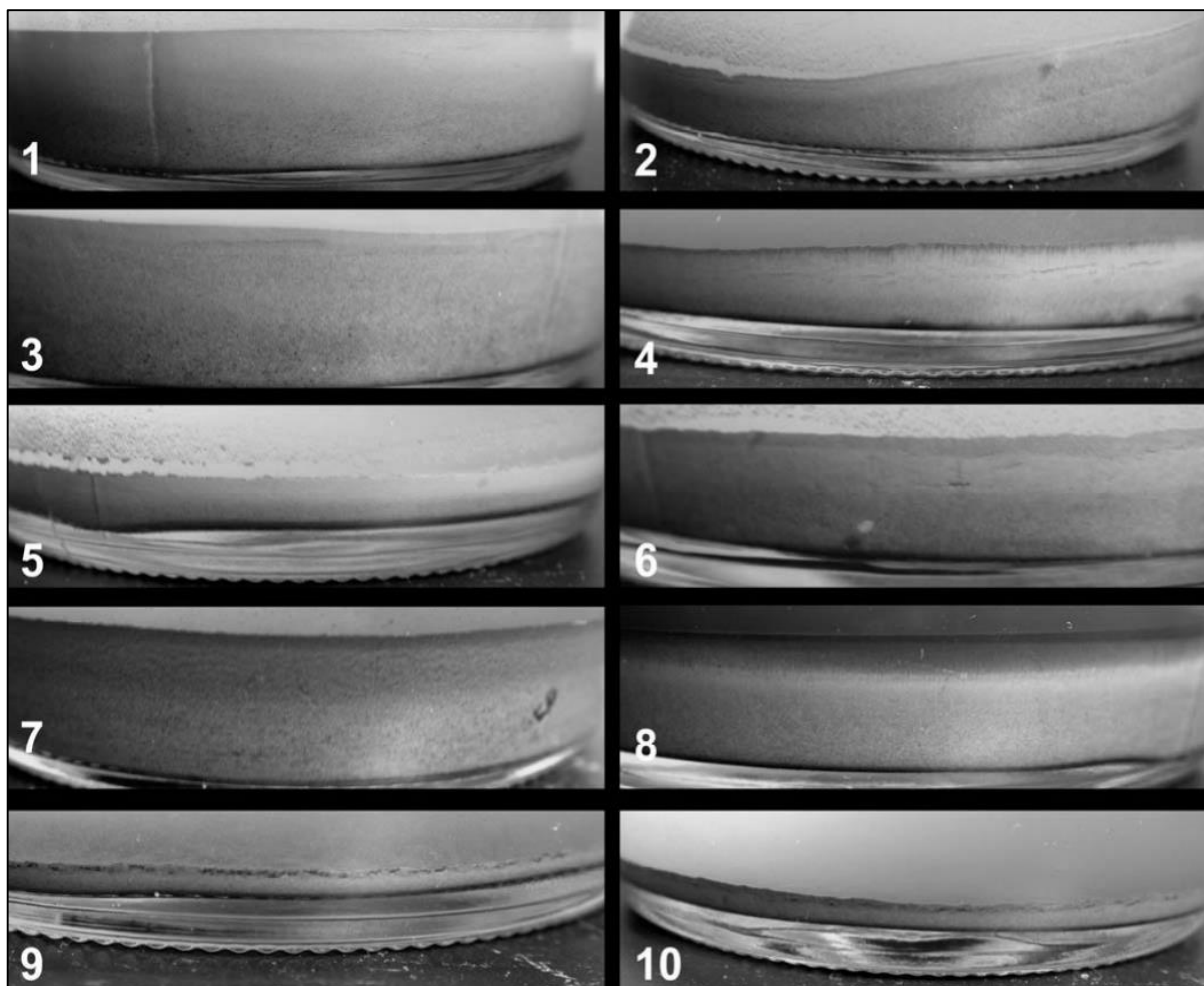


Figure F-7. Settled silt after final clay removal.

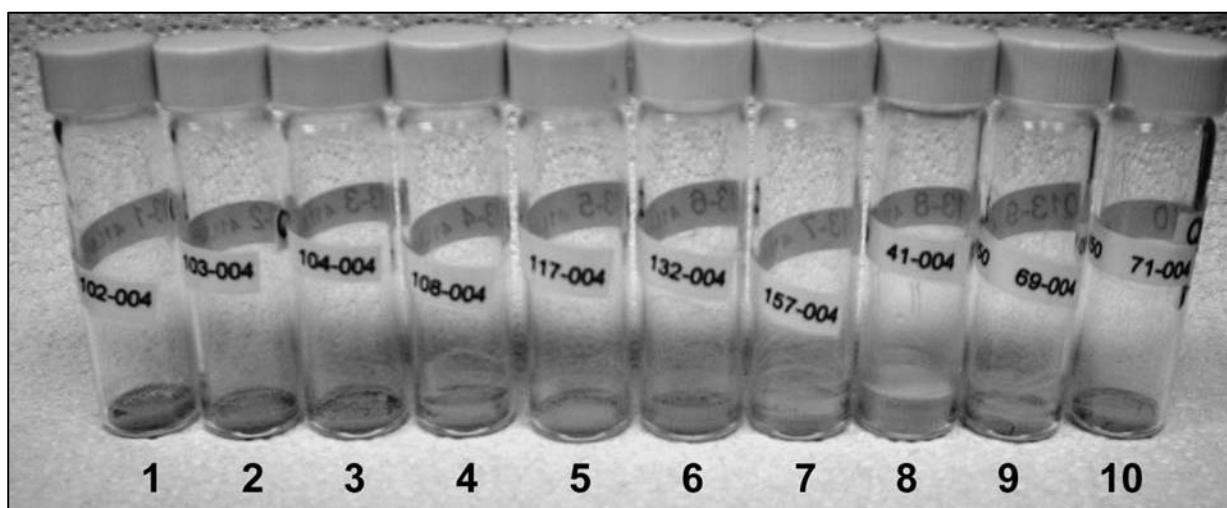


Figure F-8. Isolated phytolith fractions. Note: The samples 1-3 seem to have slightly more iron staining, whereas sample 8 shows less discoloration than the remaining samples.

The other potential negative side effect of calcareous soil is the basic pH which can negatively affect phytolith preservation. That issue will be addressed in the data section.

## **F.5 DATA AND RESULTS**

### **F.5.1 Sand**

The isolated sand fractions (Figure F-9) were dried, photographed, and examined for nonquartz components. The surface control sample (157-004) contained a great deal of organic debris (see also Figure F-5). A small snail is clearly visible in 108-004 (Figure F-9). Varying amounts of organic debris and charcoal are visible on top of the sand fractions. The sand colors were generally similar, with the 41LM50 samples being slightly redder than the 41LM51 sands.

The major difference in the two site's sand samples is the abundant fossiliferous material present in the 41LM50 samples (Figure F-10). Fragments of marine sponge spicules were very prominent A-F: Sample 41-004; G-J: Sample 69-004; and K-N: Sample 71-004. A, G-K: red fossiliferous stone fragments containing large numbers of white fossil spicule sections. B: gray fossiliferous stone containing spicules. C-E: other fossil types observed in the sand fraction. L: gray (burned?) spicule section [or from gray matrix, such as in B, which may have been burned]. B, E, F, K-L: all of the white tubular particles of various diameters are spicule sections which likely originated from decomposing fossiliferous stone. F: one spicule shows a tapered end (tip). M: end view of spicule showing axial canal (filled with clay or stone). None of these large spicules were

observed in the silt fraction. The 1 mm scale in J applies to all images in this Figure.

Throughout the sand, as well as still embedded in the small rock debris (these appear as short white cylinders (Figure F-10). Much less fossiliferous material occurs in the sands at 41LM51 (Figure F-11) which may indicate different geological sources of rock associated with features at the two sites and/or that debris traveled downstream from 41LM50 to be redeposited at 41LM51.

The samples also contained numerous snail shell fragments, as well as a variety of intact snail shells (Figures F-12 through F-14). These were recovered because the standard soil processing steps of crushing and sieving the soil prior to texture analysis were not performed. These snails identifiable, although that is beyond the scope of my expertise. Snails can provide additional environmental information (Davies 2008). Several representative unidentified specimens are also illustrated (Figure F-15). The specimen of interest in Figure F-15 B is the white spherical ball in the upper part of the image. The specimen in Figure F-15 D may be a shell or snail fragment. The two specimens in Figures 15 A and 15 C are distinctive, but not yet identified. Some flake debris was also noted in the sand (examples shown in Figure F-16).

There is a significant number of carbonate fragments with embedded sand particles at 41LM41 (Figure F-17). These carbonate fragments are part of the isolated sand fraction, and tend to skew the soil component weights used for texture analysis. One of the carbonate nodules in Figure F-17 A was placed on a microscope



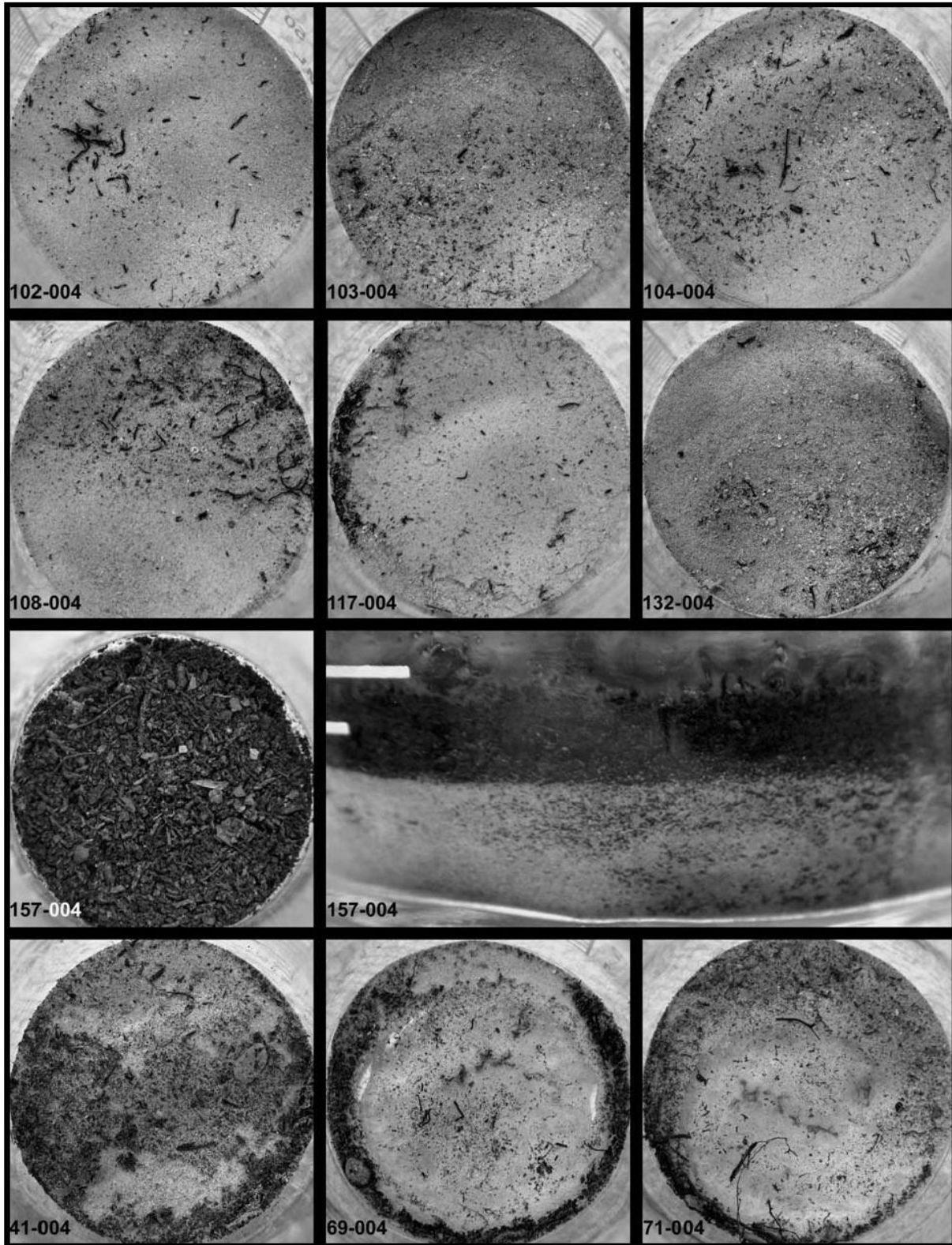


Figure F-9. Isolated sand fractions following oven drying (samples jars are about 2 inches in diameter).

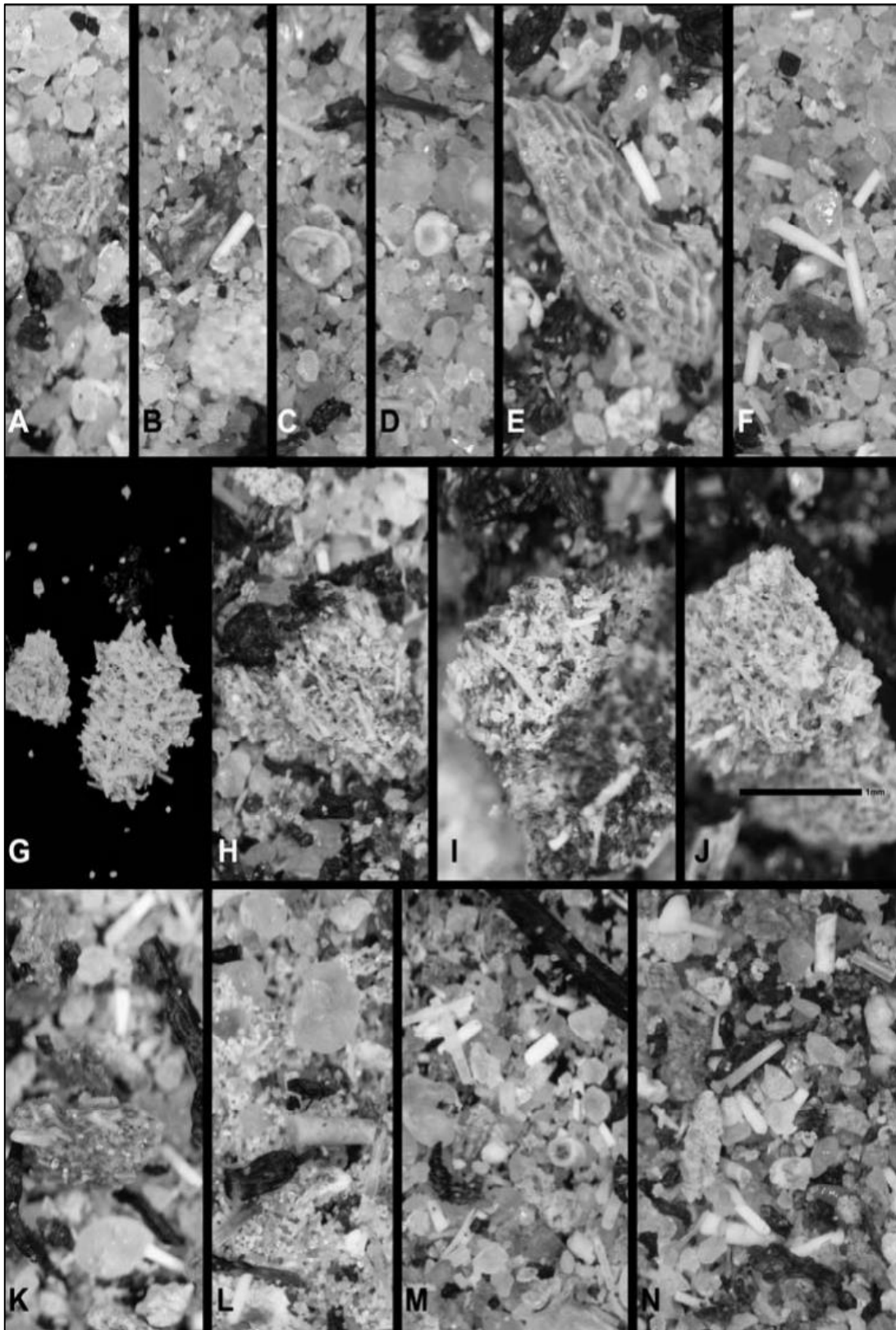


Figure F-10. Fossil sponge spicules and other fossils in the sample sand fractions (41LM50).

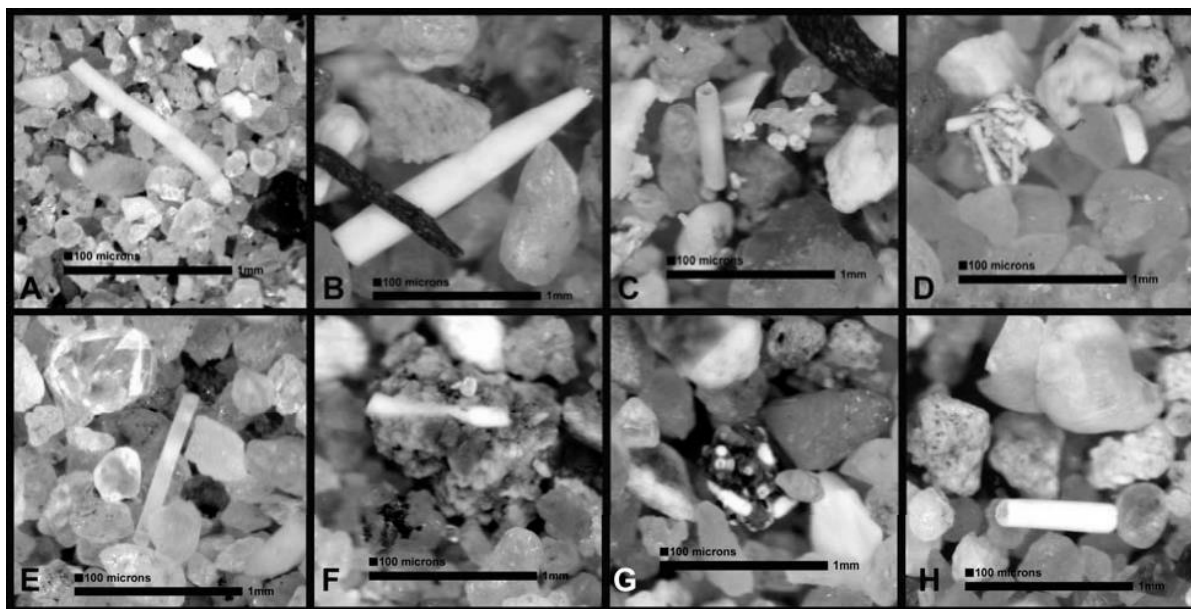


Figure F-11. Fossil sponge spicules in the 41LM51 sample sand fractions. A (sample 102-004), B (sample 103-004), C (sample 132-004), D-G (sample 104-004; flake present at the top of G), and H (sample 102-004). Scale bars are 100 microns and 1 mm.

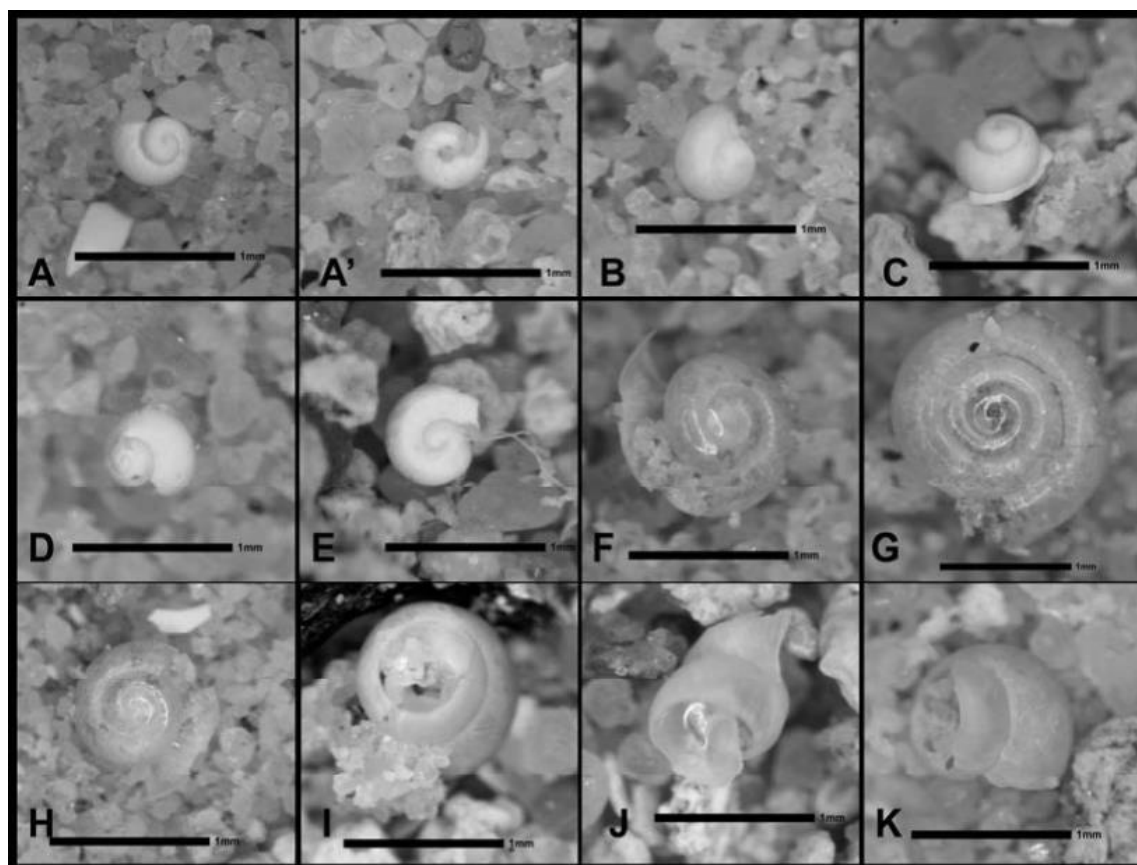


Figure F-12. Snails from 41LM51; Sample 102-004 (images A-M). Two views of A are shown. Scale bars are 1 mm.

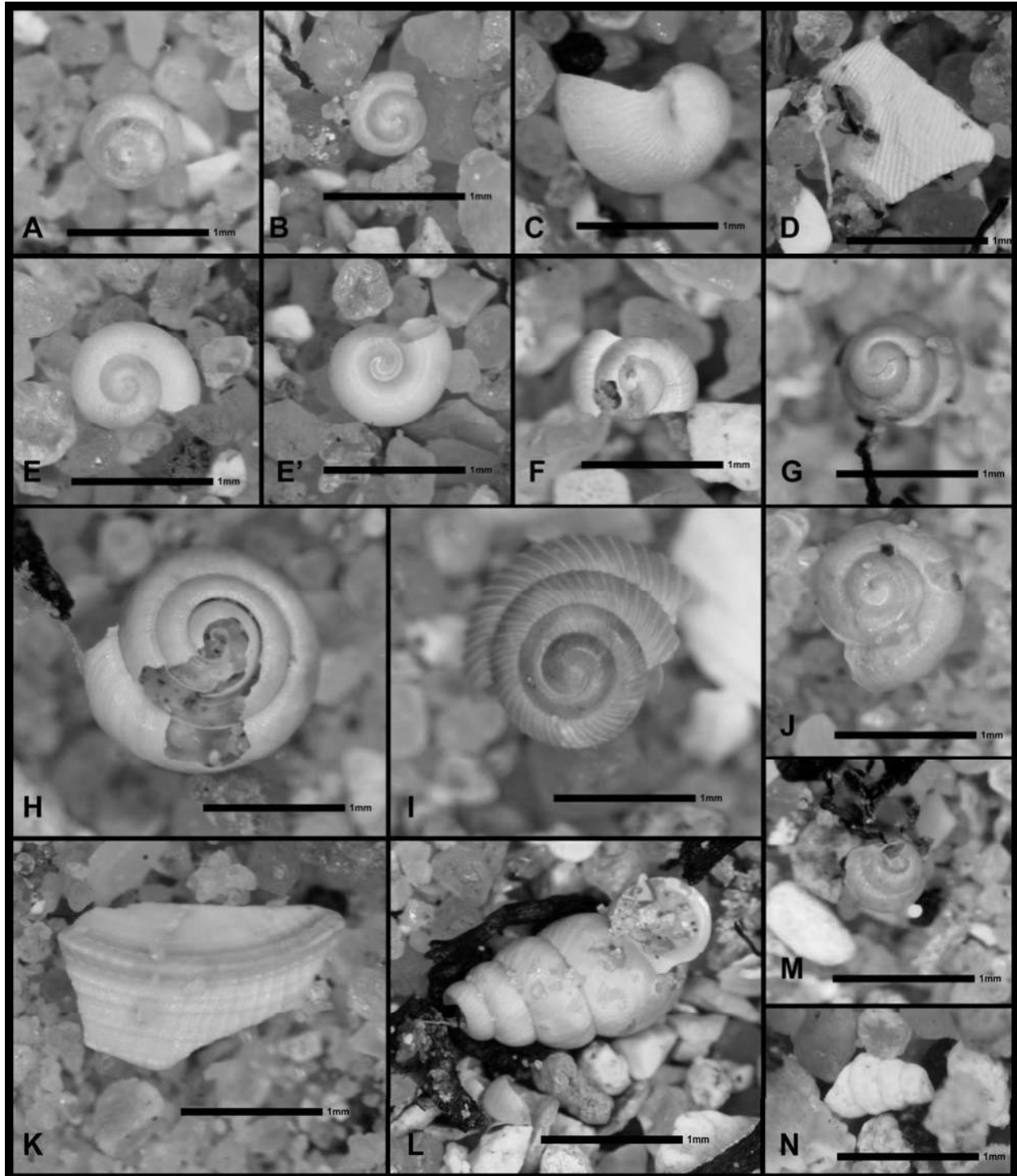


Figure F-13. Snails from 41LM51. Samples 103-004 (images A-C), 102-004 (image D), and 108-004 (image E (two views), F- N). Specimens D and K appear to be fragments of shells or large snails. Scale bars are 1 mm.



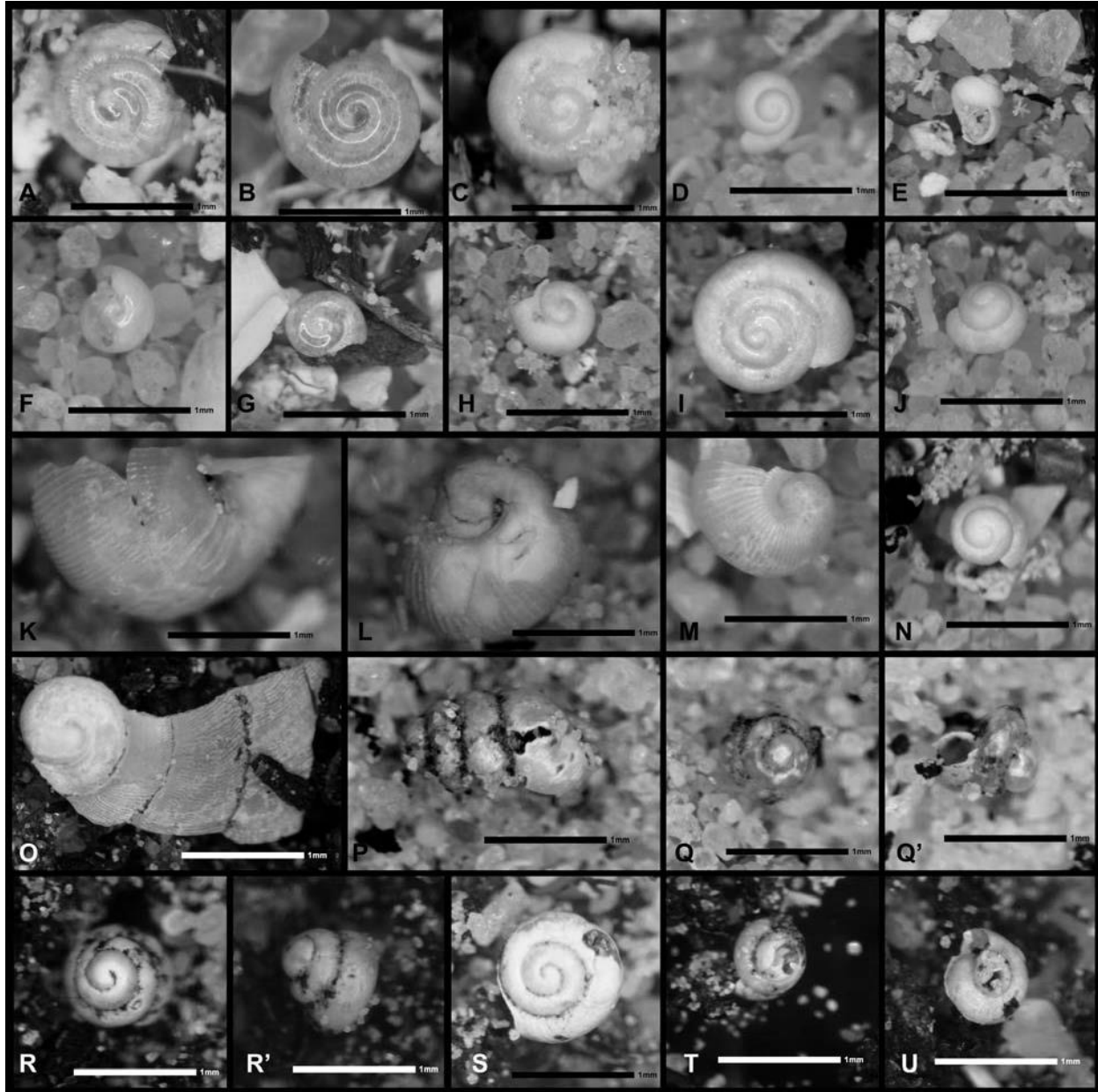


Figure F-14. Snails from 41LM51. Samples 117-004 (images A-E), 132-003 (images F-N), and 157-004 (images O-U (two views each of specimens Q and R)). Scale bars are 1 mm.

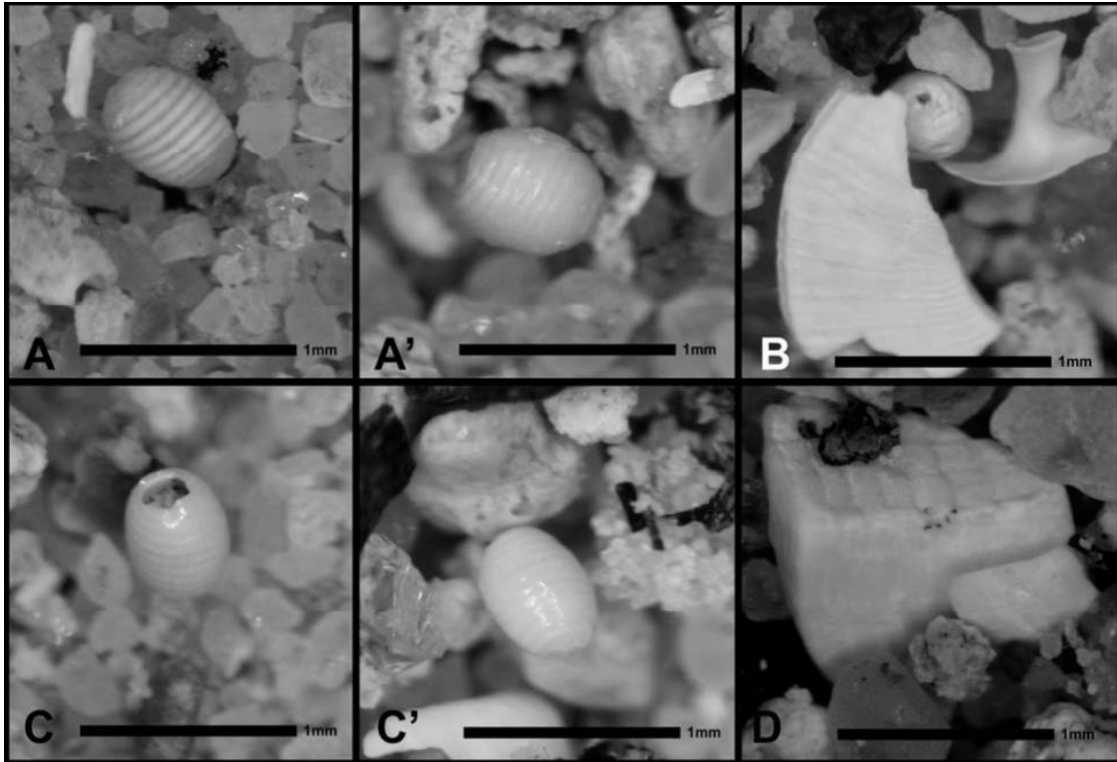


Figure F-15. Unidentified specimens (41LM51). Samples 102-004 (images A-B) and 117-004 (images C- D). Scale bars are 1 mm.

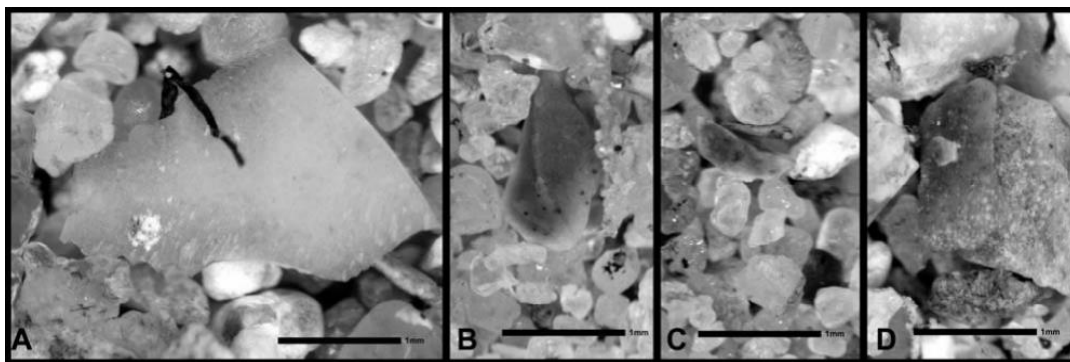
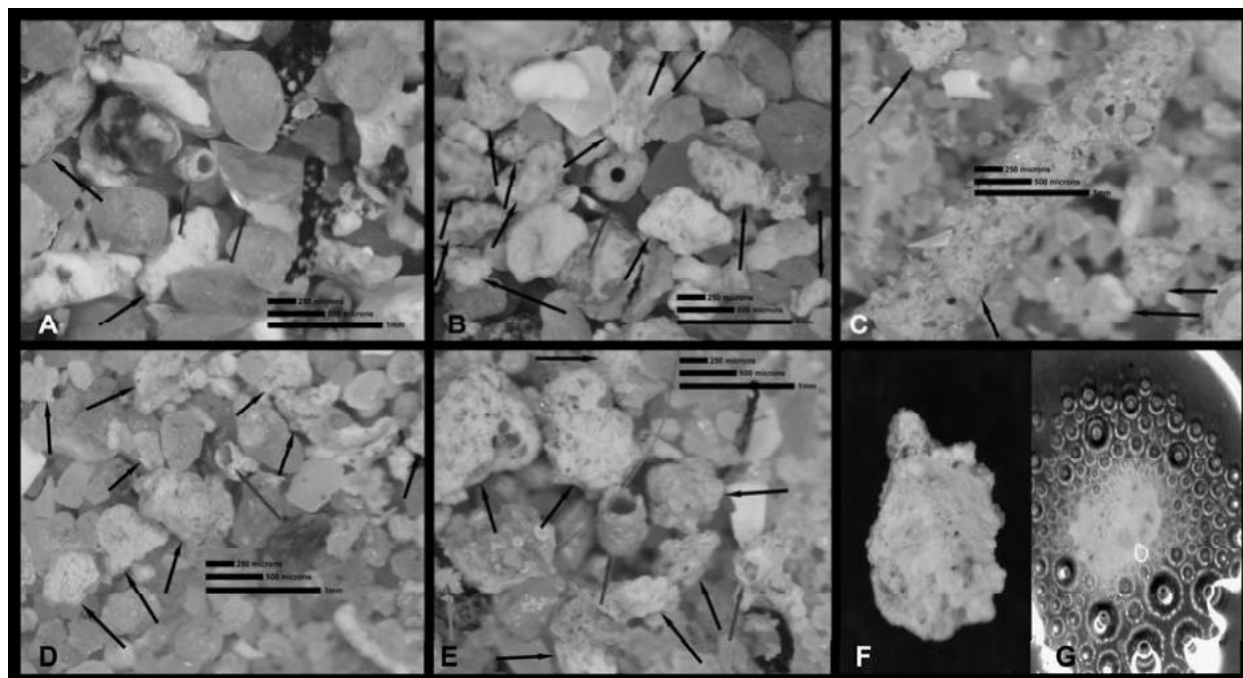


Figure F-16. Flake debris in the sand samples (41LM51). A-C Sample 103-004, and D sample 108-004. Scale bars are 1 mm.



**Figure F-17. Carbonates in 41LM51.** Images A, F-G (104-004), images B-D (sample102-04), and image E (117-004) show numerous carbonate particles in the sand fraction. Black arrows indicate chunks of carbonate, red arrows denote hollow carbonate cylinders, the green arrow indicates a small crystal cluster that may have formed in the calcareous soil, and the blue arrow indicates an angular unweathered quartz sand grain. The cylindrical body diagonal across the photograph in C is a large hollow carbonate cylinder. The carbonate granule in F was taken from 104-004 and exposed to hydrochloric acid (Image G).

slide (Figure F-17 F); 10 percent hydrochloric acid was added to the slide, and an immediate vigorous reaction occurred (Figure F-17 G) after which the carbonate was gone. Some carbonate nodules were noted in Figure F-17 that are perforated (red arrows)--quite possibly from forming around a root in the soil (for discussion of biotic and abiotic carbonate formation in soil, Monger [2002] is readily available). To confirm that these specimens behaved like carbonate, the highlighted carbonate from Figure F-17 A was placed on a microscope slide and covered with a cover slip (Figure F-18 A). Then, several drops of 10 percent HCl were added to the left edge of the cover slip, the HCl gradually flowed under the cover slip toward the sample (Figures F - 18 B-D).

Root Carbonate from Figure F-17E was placed on a microscope slide, covered with a cover slip, and

exposed to hydrochloric acid). A is dry, in B and C the HCl front advances from left to right, D shows first contact with one gas bubble formed, E shows the immediate vigorous reaction, and F shows the remaining embedded noncarbonate residue (including a small crystal cluster (red arrow) like that noted in Figure F-17E (green arrow).

### F.5.2 Phytoliths

Two or three microscope slides were prepared of each phytolith fraction sample for counting purposes at different loadings. The slide fields of view were randomly scanned as particle counts were tabulated, and images were concurrently collected of the fields of view (camera grabs about center 30 percent of field of view). The slides were then rescanned looking for other particle forms of interest that were not observed in the random field counts.

The "classic" morphologic short cell forms used in this analysis are illustrated in Figure F-19. The raw phytolith counts, counted while scanning microscope slides while visualized at 500x are summarized in Table F-2 as are the normalized seasonality phytolith grouping totals. The **blue [Poooids, cool season grasses]**, **green [Panicoids, warm moist season grasses]**, and **red [Chloridoids, hot dry season grasses]** colors are to help visualize the three groupings of short cell phytoliths used to interpret the environment. The burned short cell phytolith counts are in Table F-3, and the percent burned phytolith counts for each short cell form are in Table F-4. The *Stipa* and *Stipa* imposter phytoliths were included in the **Panicoid** fraction (see Sudbury 2011a: 73-75 for a detailed discussion). Ratios based on the data in Tables F-2 through F-4 are presented in Table F-5, and are plotted in the following discussion section (Figures F-31 through F-37). Example images are shown of probable cucurbit phytoliths (Figure F-20), possible cucurbit phytoliths (Figure F-21), small **Panicoid crosses** (Figure F-22), medium **Panicoid crosses** (Figure F-23), burned **Panicoid crosses** (Figure F-24), a probable Commelinaceae seed coat fragment (Figure F-25), and freshwater sponge spicules and gemmoscleres (Figure F-26). Particles were photographed during the formal counting scans and in later surveys of the slide searching for forms not observed during the counts; thus, illustrated specimens may be more numerous than recorded in the formal count data (Tables F-2 and F-3).

Soil textures were obtained gravimetrically (Table F-7). There are a number of issues with this data. First, the samples were not sieved to remove organic debris in order to preserve snails and any other large environmental objects that may be present. The downside of this is that large organic debris remains in the sample (cf. Figures F-4:7) causing weight distortion of the soil fractions. Second, even if the organic material was removed,

the sizeable carbonate component of the sand fraction (Figures F-17 through F-18) distorts the soil texture values. Third, due to the apparent light fraction mineral contaminant (cf. Figures F-6 and F-7), the combined silt/clay fraction was acid treated to help eliminate these mineral impurities; although they were not totally removed, they concentration decreased--again affecting the fraction weights. Even after the large organic debris was removed for the surface control sample with the sand (Figures F-3 and F-4), thermal ashing of the silt fraction caused over a 20 percent weight loss in the silt fraction (Table F-7). This loss is due to fine or dissolved organic material and/or volatile minerals. For these reasons, the texture information is presented for completeness, but not highlighted as the data is likely of minimal utility as the above caveats suggest. As to phytolith fraction weights, the poor bulliform phytolith preservation at 41LM51 (Figure F-27) indicates the possibility some short cell loss may have occurred due to dissolution. However, there were also pristine bulliform phytoliths present (Figure F-28), as well as some specimens with only one portion weathered; this may indicate that more dissolution is occurring along the ped surfaces and/or around the roots. These images show the two extremes; most specimens were between the two extremes. The bulliform and elongate specimens at 41LM51 were generally more weathered than those at 41LM50. Weathering was uniformly less severe in 41LM50 than in 41LM51.

Examples of probable tree origin phytoliths are shown in Figure F-29. Out of over 1,000 odd phytolith specimens photographed while counting samples, 22 of the larger or more interesting specimens are illustrated in Figure F-30. This researcher first encountered this phytolith form on an early Holocene site on the northern plains (Sudbury 2007). Some tracheid elements were also observed.



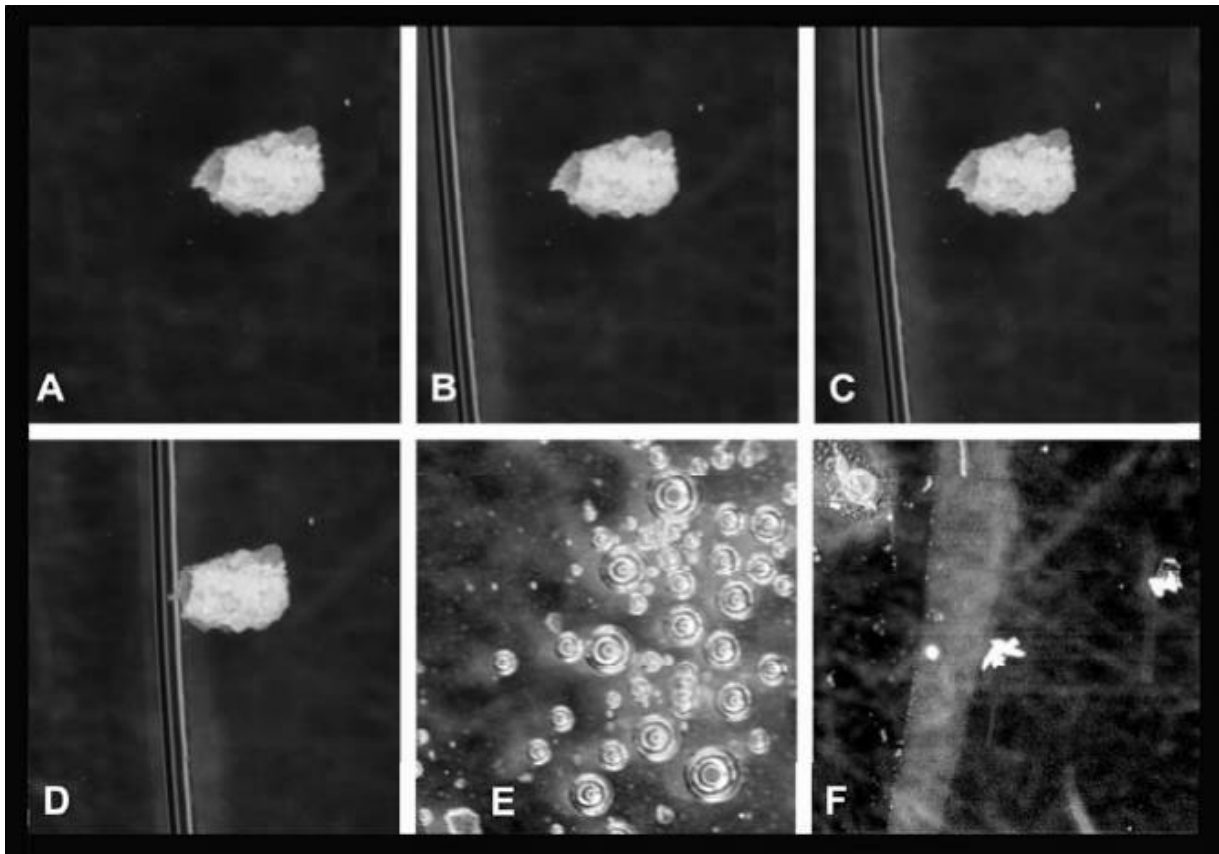
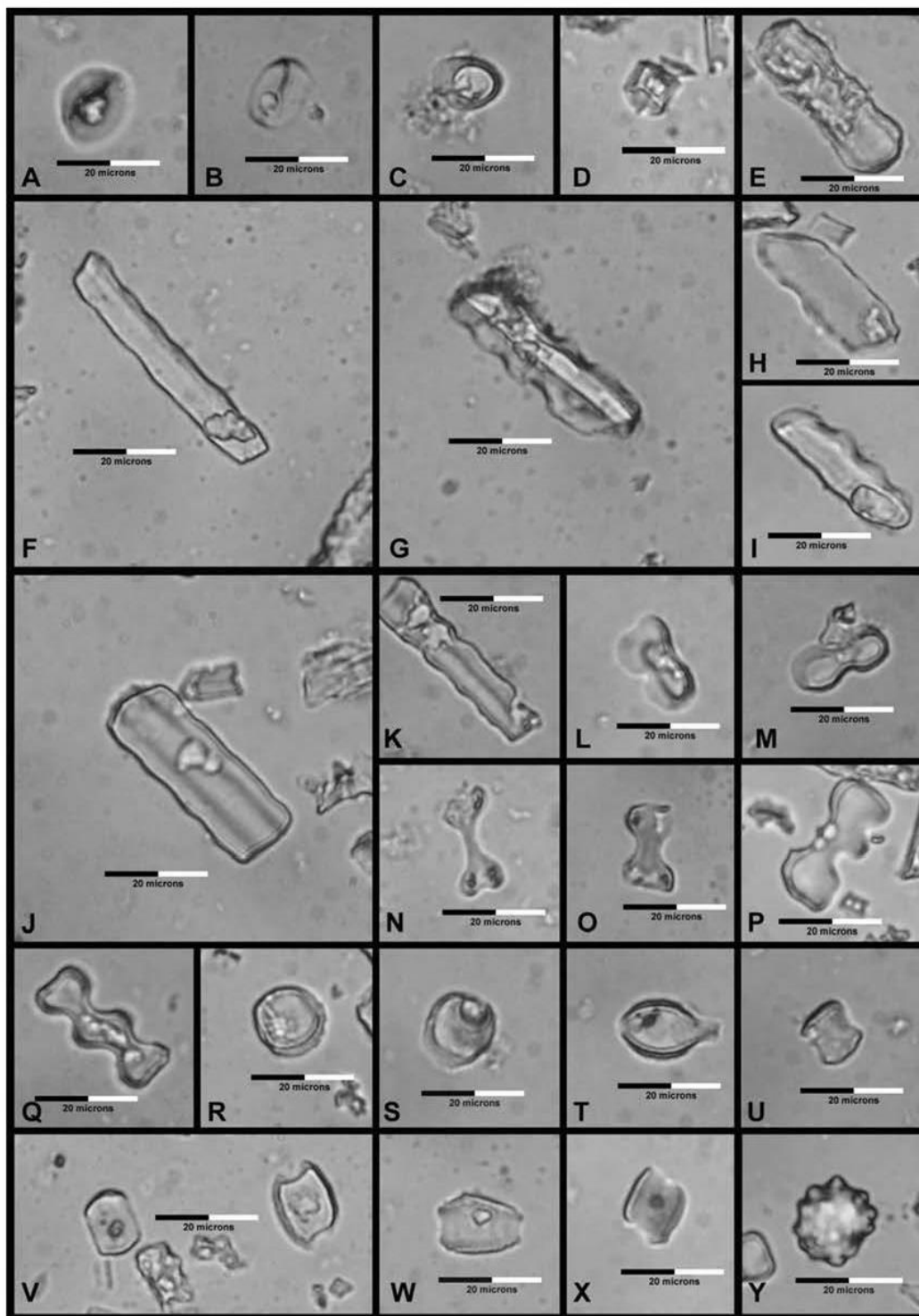


Figure F-18. Carbonate confirmation (HCl reaction).



**Figure F-19. Examples of short cell phytolith form specimens recovered at 41LM50 and 41LM51.** Keeled (A-B), conical (C), pyramidal (D), crenates (E-K), Stipa (L), lobate (M), Panicoid (N-O), polylobate (P-Q), disc (R-S), Stipa (saddle imposter; T), and saddles (U-X). The spinulose (Y) is not a short cell, but can be an indicator of trees. The specimens in A, N, O, and X appear to be burned. The Panicoid crosses are shown in Figures F-22 through F-24.

**Table F-2. Raw Phytolith Counts and Short Cell Normalized Percent.**

	41LM51							41LM50		
Sample Number ►	102-004	103-004	104-004	108-004	117-004	132-004	157-004	41-004	69-004	71-004
Depth (cmbs) ►	80-90	42-47	45-55	23-25	86-88	59-61	0	18	23	15
Sample Context	Feat 2	Feat 3	Feat 4	Natural	Natural	Natural	Natural	Natural	Feat 1	Feat 2
Time Association	EA	LA	LA	LP	EA	EA	Modern	LP	LP	LP
Morphologic Form										
Keeled	27	27	24	37	26	65	14	158	25	19
Conical	4	8	1	11	14	27	8	43	18	12
Pyramidal	34	24	25	18	42	46	14	61	20	22
Crenate	14	24	23	13	9	28.5	7	15	6	4
Stipa	12	8	7	10	11	31.5	40	108.5	18	19
Lobate, Simple	6	27.5	9	7	14.5	32.5	34	92.5	21.5	30
Lobate, Panicoid	26.5	44.5	41.5	63	52	62.5	50	307.5	34	61
Lobate, Pan'd(cmpd)		2		1	1.5	11	6	17	1	
Cross, Panicoid (<11 um)	1	5		2	4	8		7	3	2
Cross, Panicoid (>11 um)	1	2		1		1		2		
Imposter Saddle (Stipa)	2.5		1	1	3.5	3.5	1	11.5	1	1
Large Disc	2	2			2	4	2	9	4	3
Saddle, squat	20	39	25	29	17	51	21	147.5	25	23
Saddle, tall	54	40.5	47	36	59.5	75	30	318	44.5	40
Spiny spheroid	5	1		1	3					
Sponge Gemmosclere			1		1					
Sponge Spicule	1	1	2	9	8	4	1	1	0	0
Trichome, Hair Cell	28	48	31	27	38	24	6	33	7	11
Bulliform, square	34	50	60	25	73	65	9	32	21	44
Bulliform, rectangular	181	144	187	96	257	207	25	99	77	77
Bulliform, keystone	66	15	32	26	77	41	9	21	15	35
Bulliform, Y-shaped		32	7	2	9	17	1	4	2	6
Bulliform, other	363	119	222	104	266	647	21	303	65	62

	41LM51							41LM50		
Sample Number ►	102-004	103-004	104-004	108-004	117-004	132-004	157-004	41-004	69-004	71-004
Elongate, smooth	28	11	15	18	42	39	17	133	6	8
Elongate, sinuous	28	5	22	8	37	25	5	33	1	6
Elongate, castillate	8	5	8	5	14	20	2	15		1
Elongate, spiny		1	1	3	5	3	1			
Sedge	1	2	1	1	2	3		4	0	1
Charcoal	219	71	74	23	224	243	6	15	14	15
Diatom		1					4	20		
Smooth Sphere	12	7	3	3	22	18	1	6	8	6
Possible Cucurbits	9	2	5	3	7	10		5	5	
Mineral Contaminants	7	4	9	2	8	17	4		3	
Burned Tabular Silica	7			3	8	6		10	19	6
Tree (angular phytoliths)	57	11	10	26	80	36	4	15	22	8
Embedded Spheres	22	23	7	6	5	23	1	3	11	2
Commelinaceae			1							
Statospores	3	1			1			1	1	
Normalized %										
Pooid %	38.7%	32.7%	35.9%	34.5%	35.5%	37.3%	18.9%	21.3%	31.2%	24.2%
Panicoid %	25.0%	35.9%	28.7%	37.1%	34.6%	34.5%	58.6%	42.8%	37.3%	49.2%
Chloridoid %	36.3%	31.4%	35.4%	28.4%	29.9%	28.2%	22.5%	35.9%	31.4%	26.7%

The raw phytolith counts, counting while scanning microscope slides while visualized at 500x are summarized in Table F-2. The blue [Pooids, cool season grasses], green (Panicoids, warm moist season grasses), and red [Chloridoids, hot dry season grasses] colors are to help visualize the three groupings of short cell phytoliths used to interpret the environment.

**Table F-3. Burned Short Cell Phytolith Counts.**

Sample Number ►	41LM51							41LM50		
	102-004	103-004	104-004	108-004	117-004	132-004	157-004	41-004	69-004	71-004
Depth (cmbs) ►	80-90	42-47	45-55	23-25	86-88	59-61	0	18	23	15
Sample Context	Feat 2	Feat 3	Feat 4	Natural	Natural	Natural	Natural	Natural	Feat 1	Feat 2
Time Association	EA	LA	LA	LP	EA	EA	Modern	LP	LP	LP
Morphologic Form										
Keeled	7		1	5	6			10	1	
Conical	1				1	1				
Pyramidal				1	1					
Crenate	1									
Stipa				1	1			5		
Lobate, Simple			1					3.5	1	
Lobate, Panicoid	3.5	2	2.5	16	13.5	9	3	23	3.5	0.5
Lobate, Pan'd (cmpd)					1.5			1		
Cross, Panicoid (<11 um)		1		2	2	1		4		
Cross, Panicoid (>11 um)				1				1		
Imposter Saddle (Stipa)	0.5		0.5		0.5			0.5		
Large disc	2							1	1	1
Saddle, squat				6	2			3	2	
Saddle, tall	5			5	4			8		

**Table F-4. Burned: Total Short Cell Phytolith Counts (Normalized).**

Sample Number ►	41LM51							41LM50		
	102-004	103-004	104-004	108-004	117-004	132-004	157-004	41-004	69-004	71-004
Depth (cmbs) ►	80-90	42-47	45-55	23-25	86-88	59-61	0	18	23	15
Sample Context ContextContext	Feat 2	Feat 3	Feat 4	Natural	Natural	Natural	Natural	Natural	Feat 1	Feat2
Time Association	EA	LA	LA	LP	EA	EA	Modernn	LP	LP	LP
Morphologic Form										
Keeled	26 %		4.2 %	14 %	23 %			6.3 %	4.0 %	
Conical	25 %				7.1 %	3.7%				
Pyramidal				5.6 %	2.4 %					
Crenate	7.1 %									
Stipa				11 %	9.1 %			4.6 %		
Lobate, Simple			11 %					3.8 %	4.7 %	
Lobate, Panicoid	13 %	4.5 %	6.0 %	25 %	26 %	18.0%	6.0 %	7.5 %	10.0%	0.8 %
Lobate, Pan'd (cmpd)					100 %			5.9 %		
Cross, Panicoid (<11 um)		20 %		100 %	50 %	13 %		14 %		
Cross, Panicoid (>11 um)				100 %				50 %		
Imposter Saddle (Stipa)	20 %		50 %		14 %			4.3 %		
Large disc	100.0%							50 %	100 %	100 %
Saddle, squat				21 %	12 %			2.0 %	8.0 %	
Saddle, tall	9.3 %			14 %	6.7 %			2.5 %		

**Table F-5. Summary of Major Particle Forms Observed.**

Sample Number ►	41LM51							41LM50		
	102-004	103-004	104-004	108-004	117-004	132-004	157-004	41-004	69-004	71-004
Depth (cmbs) ►	80-90	42-47	45-55	23-25	86-88	59-61	0	18	23	15
Sample Context ContextContext	Feat 2	Feat 3	Feat 4	Natural	Natural	Natural	Natural	Natural	Feat 1	Feat2
Time Association	EA	LA	LA	LP	EA	EA	Modernn	LP	LP	LP
Morphologic Form										
Poid Total	79	83	73	79	91	166.5	43	277	69	57
Panicoid Total (+Stipa&Imp)	51	91	58.5	85	88.5	154	133	555	82.5	116
Chloridoid	74	79.5	72	65	76.5	126	51	465.5	69.5	63
Large discs	2	1				4	2	2	1	1
Imposter Panicoid	2.5		1	1	3.5	3.5	1	11.5	1	1
Short Cell Total	204	253.5	203.5	229	256	446.5	227	1297.5	221	236
Bulliform total	644	360	508	253	682	977	65	459	180	224
Charcoal Total	219	71	74	23	224	243	6	15	14	15
Diatom Total		1					3	20		
Sedge Total	1	2				3			3	1
Possible Cucurbits	9	2	5	3	7	10		5	5	
Commelinaceae			1							
Statospores	3	1			1			1	1	

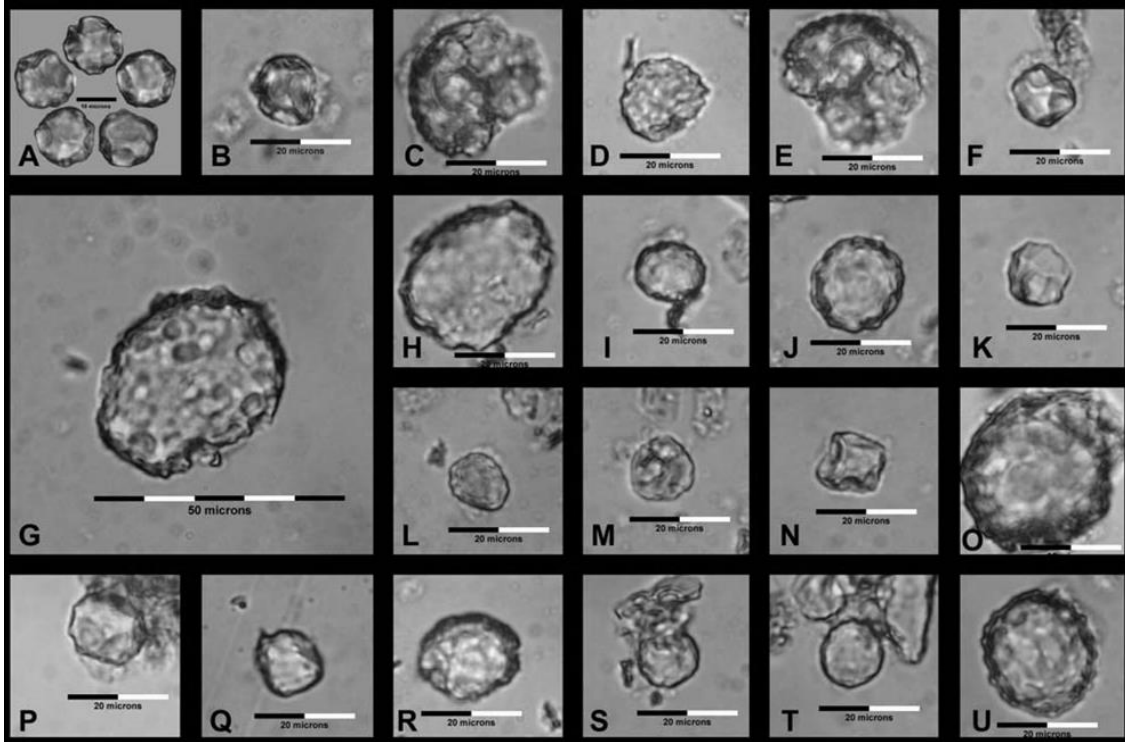
**Table F-6. Ratios of Short Cell Phytolith Forms and Burned Particles.**

Sample Number ►	41LM51							41LM50		
	102-004	103-004	104-004	108-004	117-004	132-004	157-004	41-004	69-004	71-004
Depth (cmbs) ►	80-90	42-47	45-55	23-25	86-88	59-61	0	18	23	15
Sample Context ContextContext	Feat 2	Feat 3	Feat 4	Natural	Natural	Natural	Natural	Natural	Feat 1	Feat2
Time Association	EA	LA	LA	LP	EA	EA	Moder	LP	LP	LP
Morphologic Form/Ratio										
Chloridoid (Short:Tall)	0.370	0.963	0.532	0.806	0.286	0.680	0.700	0.464	0.562	0.575
Short Cell:Bulliform	0.317	0.704	0.401	0.905	0.375	0.457	3.492	2.827	1.228	1.054
Tree Phytoliths:Charcoal	0.260	0.155	0.135	1.130	0.357	0.148	0.667	1.000	1.571	0.533
Tree Phyto:Embedded spheres	2.591	0.478	1.429	4.333	16.00	1.565	4.000	5.000	2.000	4.000
Total Short Cells	204	253.5	203.5	229	256	446.5	227	1297.5	221	236
Total Burned Short Cells	20	3	5	37	32.5	11	3	60	9.5	1.5
Total Burned Short Cells (%)	9.8%	1.18%	2.5%	16.2%	12.7%	2.5%	1.3%	4.6%	4.3%	0.64%
Total Burned SC:Tree Phytoliths	0.351	0.273	0.5	1.423	0.406	0.306	0.75	4.00	0.432	0.188

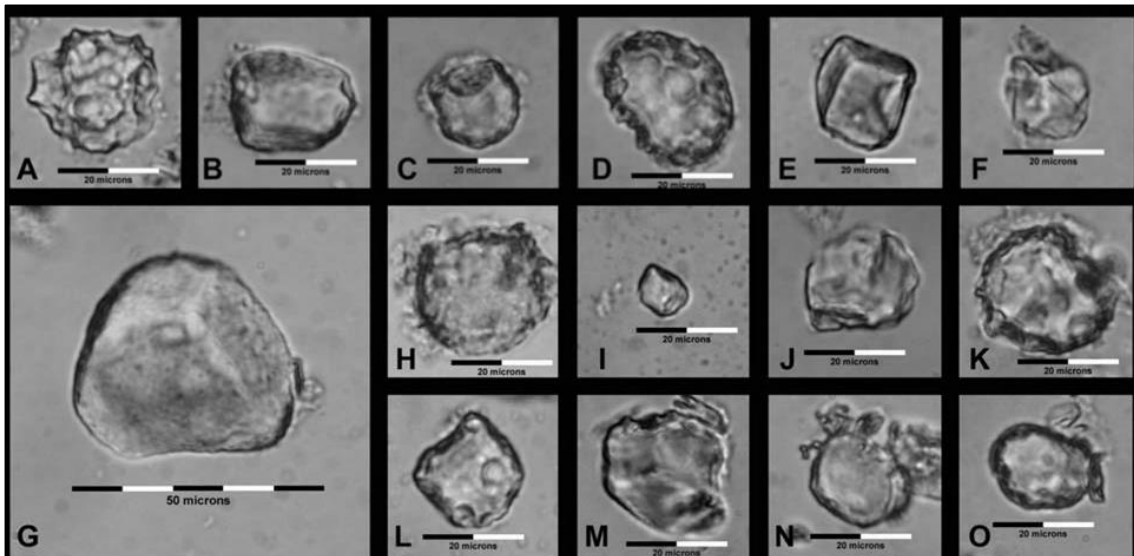
**Table F-7. Soil Texture Data.**

Depth (cmbs)	Laboratory Sample #	Field Sample #	Sand (wt.%)	Silt (ashed)	Clay by Difference	Soil Texture	Silt Loss on ashing
0	7	157-004	72.0%	13.1%	14.9%	sandy loam	21.14%
15	10	71-004	30.8%	30.0%	39.2%	clay loam	5.46%
18	8	41-004	22.8%	36.3%	40.9%	clay	4.18%
23	9	69-004	31.6%	29.6%	38.9%	clay loam	6.86%
23-25	4	108-004	75.3%	8.2%	16.5%	sandy loam	5.70%
42-47	2	103-004	49.2%	28.6%	22.2%	loam	1.05%
45-55	3	104-004	45.8%	31.8%	22.5%	loam	1.05%
59-61	6	132-004	62.8%	13.0%	24.2%	sandy clay loam	1.97%
80-90	1	102-004	47.4%	23.4%	29.2%	sandy clay loam	1.03%
86-88	5	117-004	67.2%	10.1%	22.7%	sandy clay loam	1.80%

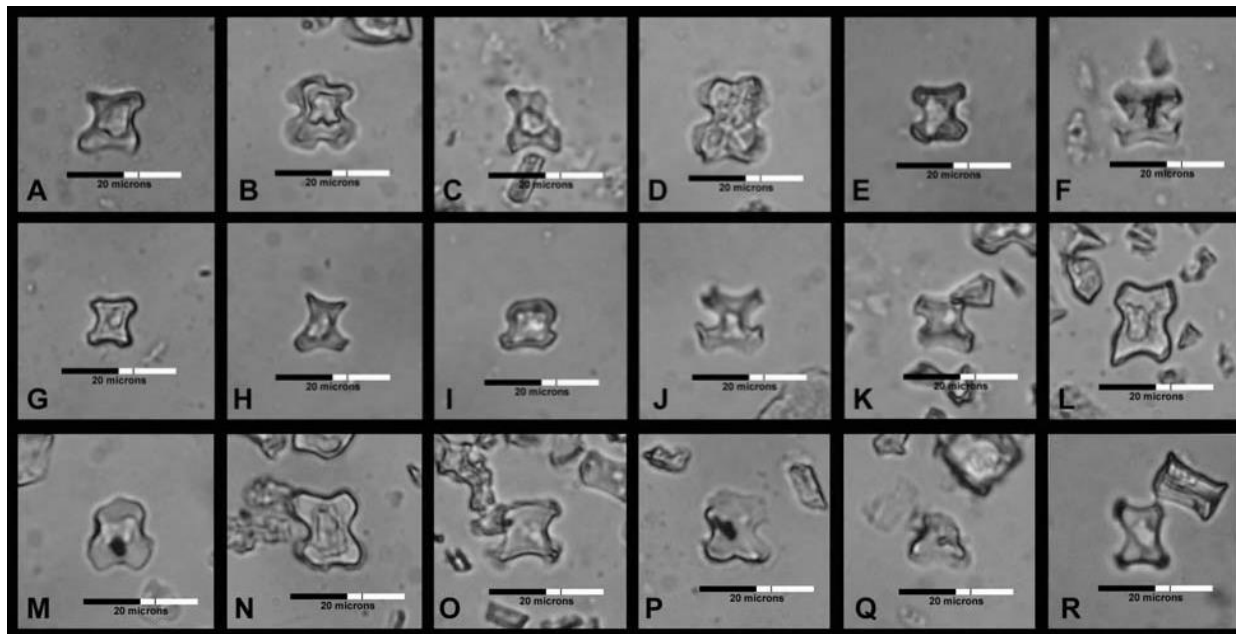




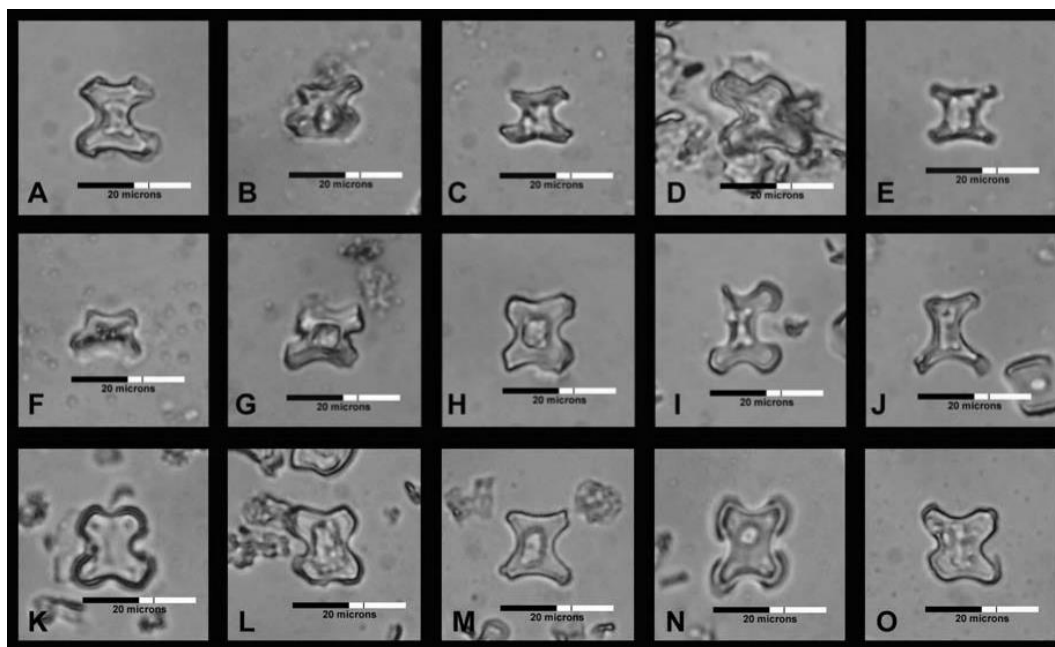
**Figure F-20. Cucurbit phytoliths from 41LM50 and 41LM51.** Specimens A-C (sample 102-004), specimens D-E (sample 103-004), specimens F-H (sample 104-004), specimen I (sample 108-004), specimens J-M (sample 117-004), specimens N-P & U (sample 132-004), specimen Q (sample 41-004), and specimens R-T (sample 69-004). Specimen A shows five views of the same phytolith after repositioning (A slightly reduced; the other images all to the same scale).



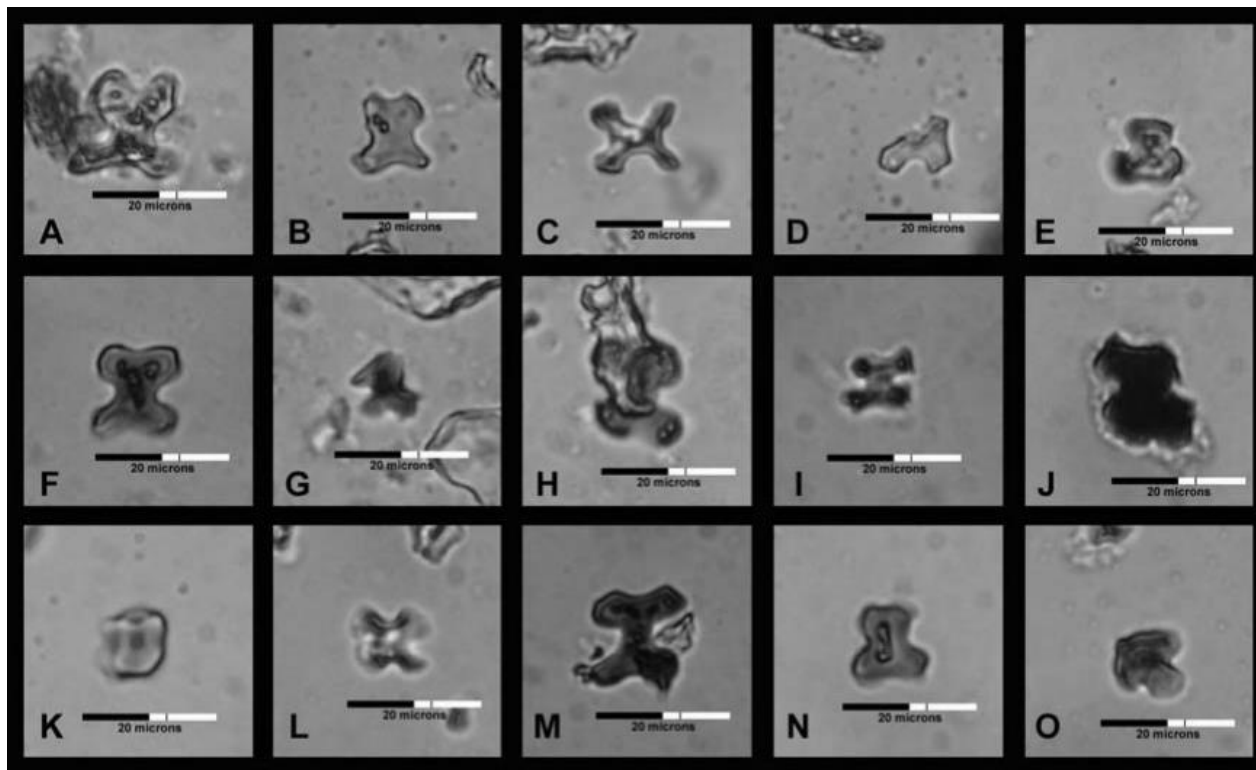
**Figure F-21. Possible cucurbit phytoliths from 41LM50 and 41LM51.** Specimens A-B (sample 102-004), specimens C-D (sample 104-004), specimens E, F, and H (sample 117-004), specimen G (sample 108-004), specimens I-M (sample 132-004), and specimens N-O (sample 69-004).



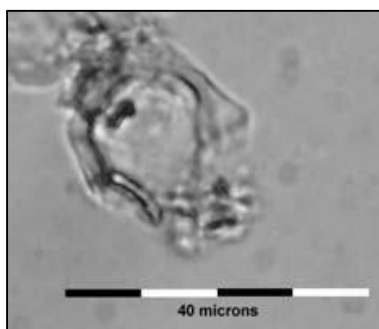
**Figure F-22. Small Panicoid cross phytoliths from 41LM50 and 41LM51.** Specimen A (sample 102-004), specimens B-C (sample 103-004), specimen D (sample 104-004), specimens E-F (sample 117-004), specimens G-I (sample 157-004), specimens J-O (sample 41-004), specimen P 9 (sample 69-004), and specimens Q-R (sample 71-004).



**Figure F-23. Medium Panicoid cross phytoliths from 41LM50 and 41LM51.** Specimen A (sample 102-004), specimens B-C (sample 103-004), specimen D (sample 108-004), specimens E-F (sample 117-004), specimens G-H (sample 132-004), and specimens I-O 8 (sample 41-004).



**Figure F-24. Burned Panicoid cross phytoliths from 41LM50 and 41LM51.** Specimen A (sample 103-004), specimens B-E (sample 108-004), specimens F-J (sample 117-004), specimen K (sample 132-004), specimen L (sample 41-004), and specimens M-O (sample 69-004).



**Figure F-25. Commelinaceae seed coat fragment (sample 104-04).**

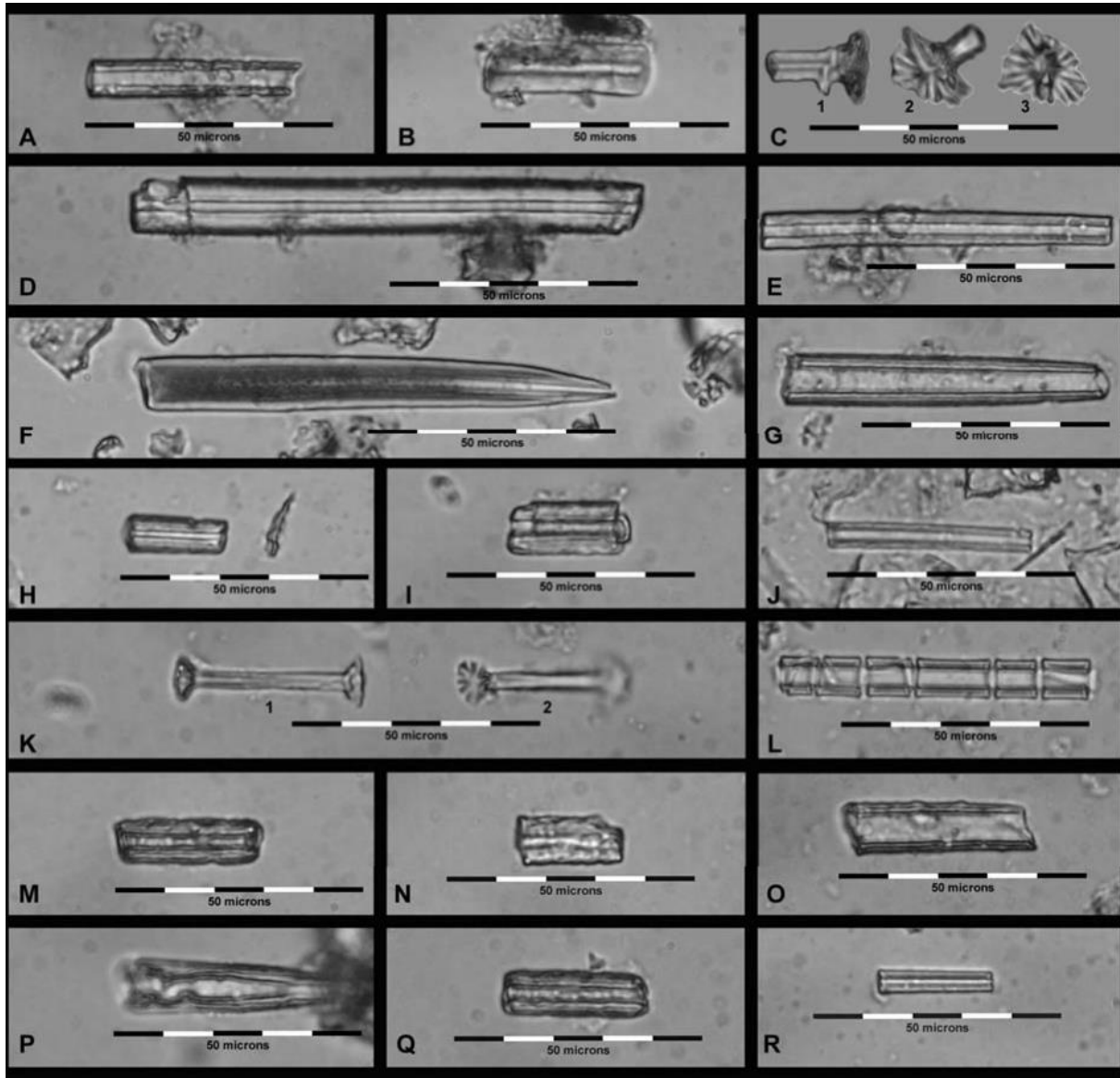
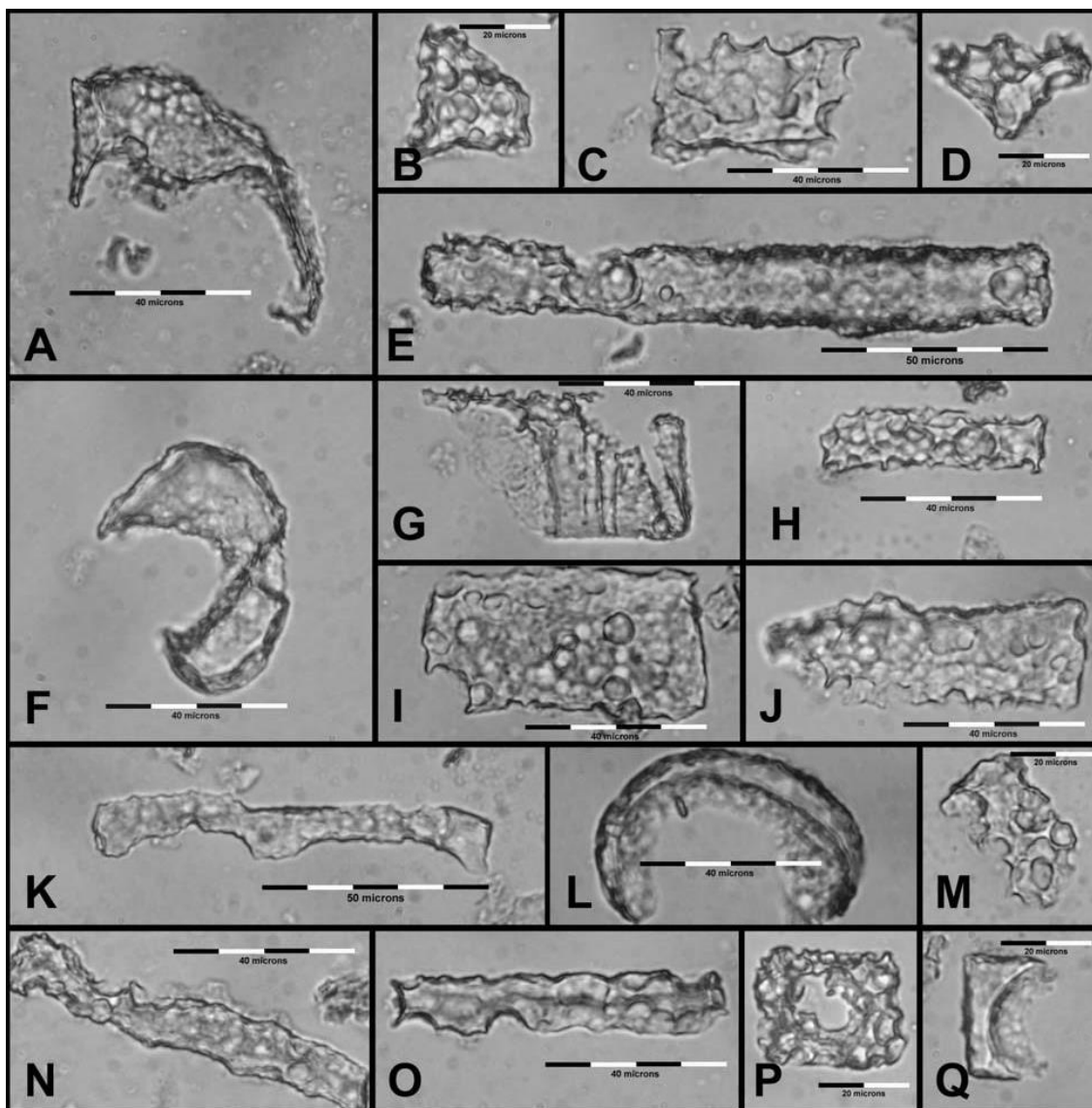


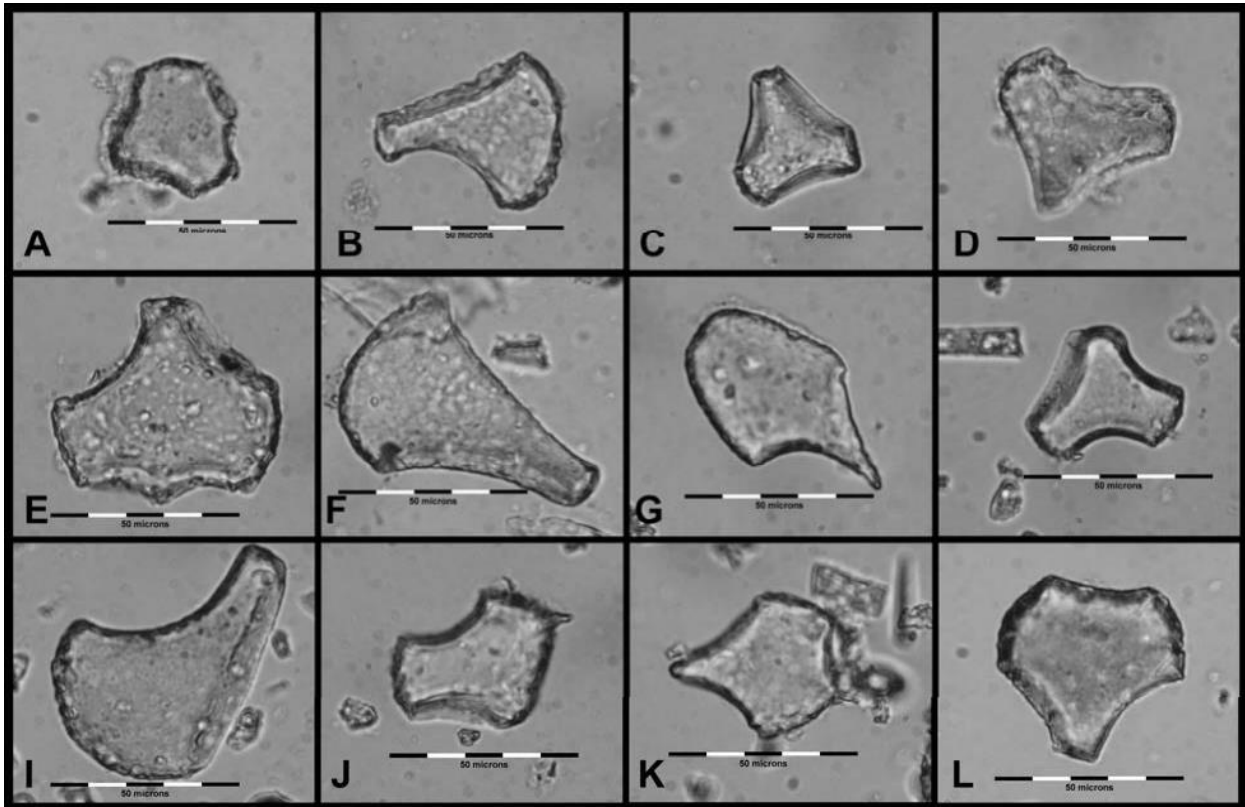
Figure F-26. Freshwater sponge spicules, gemmoscleres, and similar particles from 41LM51.

- A (sample 102-004), specimen
- B (sample 103-004), specimens
- C-D (sample 104-004), specimens
- E-I (sample 108-004), specimens
- J-P (sample 117-004), specimen
- Q (sample 132-004), and specimen
- R (sample 157-004).

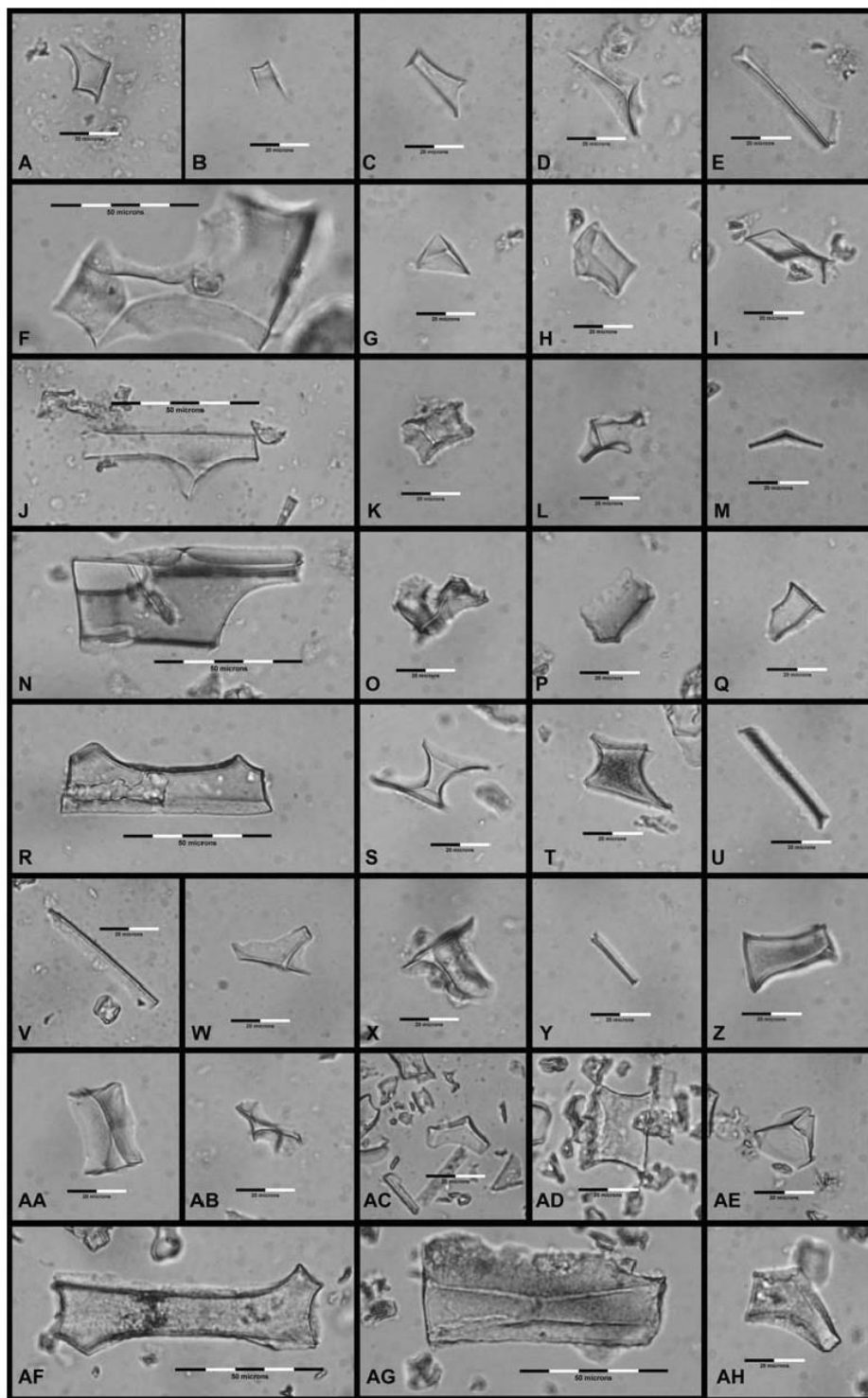
Images C and K are gemmoscleres (multiple views of each gemmosclere are shown); the identity of the particles shown in L and O is uncertain.



**Figure F-27. Heavily weathered bulliform and elongate phytoliths.** Images A-B (sample 102-004), C-I (sample 103-004), J (sample 104-004), K (sample 108-004), L-O (sample 117-004), P- Q (sample 132-004).

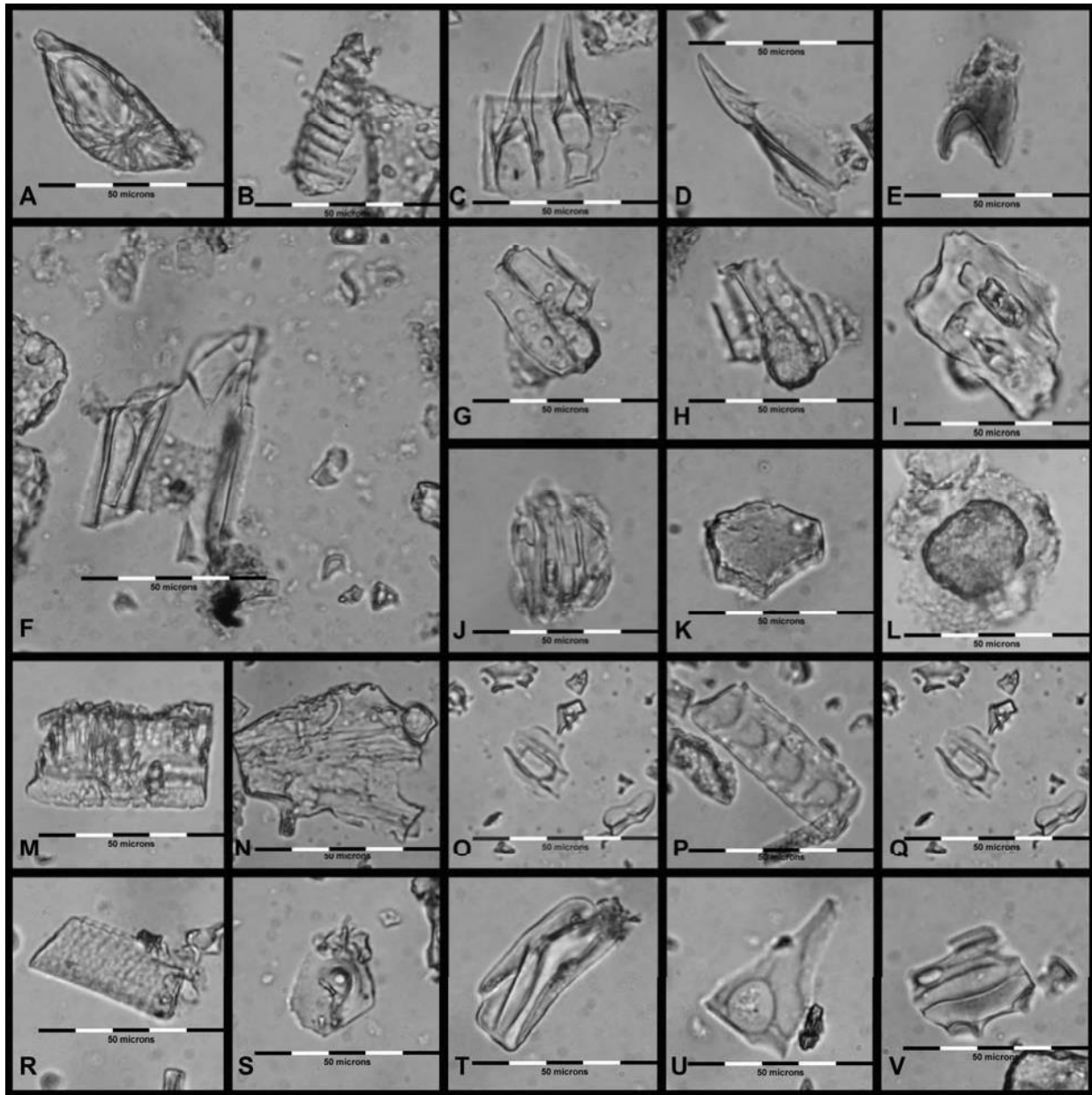


**Figure F-28. Representative good condition bulliform phytoliths.** Images A-B (102-004), image C (103-004), image D (104-004), image E (108-004), image F (117-004), image G (132-004), images H-I (41-004), images J-K (69-004) and image L (71-004).



**Figure F-29. Tree phytoliths.** Images A-D (102-004); images E-1 (108-004); images J-Y (117-004); images Z-AB (132-004); images AC, AD, and AF (41-004); and images AE, AG, and AH (69-004). Several specimens appear to have been burned (c.f. N-P, T, Z, and AG). Specimen F may be a flake of obsidian (see Sudbury 2013:748, Figure B-30). Scales are 20 and 50 microns in 10 micron increments.





**Figure F-30. Large unidentified plant phytoliths.** Image A (104-004); images B-D (108-004); images E-I and K (117-004); images J and I (132-004); image M (157-004); images N-Q (41-004); images R-U (69-004); and image V (71-004). Based on description, K may be from Ulmaceae (Bozarth 1992:212). E and V appear to be burned. The specimen in E matches a specimen reported from the Long View site which was also burned (Sudbury 2013:750, Figure B-32 B).  
Scale bar is 50 microns in 10 micron increments.



## F.6 DISCUSSION

Lines of evidence recovered but not interpreted in this discussion include snails (abundant), statospores (limited sample and interpretive data), and diatoms (relatively scarce). This discussion addresses other biogenic silica--primarily phytoliths with a brief mention of sponge spicules and gemmoscleres.

Sponges synthesize a biogenic silica support structure composed of long needle-like spines called spicules. As with plants containing phytoliths, when a sponge dies their "skeleton" is resilient and thus deposited in sediments. Many of the sponge spicule sections recovered from 41LM51 appear to be heavily weathered and pitted--possibly suggesting extensive tumbling and abrasion as they moved down stream (Figure F-26 M, N, and Q). This indicates relatively turbulent water flow prior to deposition. These heavily pitted specimens also tend to be smaller and their broken ends have been rounded off. However, these spicule sections were deposited in what later became a calcareous soil (41LM51) which could have had a deleterious effect on their surface. The basic pH of the soil environment can potentially lead to varying degrees spicule dissolution--the same process that was obvious in bulliform phytoliths (Figure F-27). Other specimens from 41LM51 show a finer surface abrasion--which could mean less vigorous tumbling and/or short distance transported; another possibility is that these finely abraded particles could represent aeolian deposition (Figure F-26 A, B, D, P). In general, most of the specimens from 41LM50 show little if any abrasion; when abrasion is apparent it is often a much finer abrasion (Figure F-26 E through I).

Of particular note in the collection are the two sponge gemmoscleres recovered from 41LM51 that show minimal abrasion (Figures F-26 C and F-26 K). Gemmoscleres are important for sponge species survival. They are part of the sponge's

reproductive mechanism. Gemmules--which are spheres with the axially aligned gemmoscleres forming the outer "wall" of the gemmule as a layer or shell protecting the sponge larvae inside--are released from adult sponges to establish new sponge colonies. Another trigger causing sponges to form gemmules is extreme environmental conditions; in this case, the gemmule is a means to essentially suspend activity and hunker down until better times when conditions improve (similar in function to a bacterial spore).

Although the two gemmoscleres recovered from 41M51 could be redeposited (aeolian or alluvial) their minimal wear argues for a local origin--implying that sponge colonies were nearby. Their presence in the site sediments could represent any one of a number of mechanisms including overbank deposits during flooding, excrement on site, being released from offal during animal butchering, or from intentionally transporting water to the site. A detailed description of the North American sponge varieties is available (Harrison 1974), as is recent study of a large early to mid-Holocene archeological assemblage containing gemmoscleres of multiple species (Sudbury 2011a).

Zoologists base species identification of extant freshwater sponges on the total assemblage of particles in an individual specimen (macroscleres [large spicules], microscleres [small spicules], and gemmoscleres). Of those three particle types, only gemmoscleres can enable species identification on their own merits--in some cases. There remains considerable debate between Porifera experts about sponge species with descriptions and nomenclature in an ongoing state of flux; even the number of North American freshwater sponge varieties cannot be agreed upon (the upper limit of the range is 33 genera).

The presence of the spike on the shaft and the larger size of the broken gemmosclere (Figure

F-26 C) tentatively place it as a member of the *Heteromeyenia* sp. The five species this genus inhabit a wide variety of habitats. If the tips of the rotule are broken off (or weathered), it is possible this could be a different species.

Comparing with the summary sketches provided by Reisinger, Frost, and Ricciardi (2010:120), the complete 41LM51 sample appears to represent *Corvomeyenia everetti* (Figure 26 K). This is based on the size range, slender nature, profile of rotule morphology, and the lack of additional ornamentation. The following comments about *Corvomeyenia everetti* were gleaned from a number of sources by Harrison (1974:40) and are condensed here: the sponge grows in well-lit (clear) still water with low mineral and inorganic content (19 micromhos/cm is the upper conductivity limit) with a somewhat acidic pH (5-6.6). This specimen was recovered from the deepest sediment analyzed (the Early Archaic period at 41LM51).

The phytolith short cell signatures of these soil samples are the major thrust of this investigation. No distinctive phytoliths indicative of maize or beans were observed. Some probable cucurbit phytoliths were noted in most soil samples (Table F-2 and Figures F-20 through 21). The only identifiable phytolith possibly indicative of gathering activities in one specimen of a Commelinaceae seed phytolith (Figure F-25).

The phytolith short cell signatures of these soil samples are the major thrust of this investigation. The only identifiable phytolith is possibly indicative of gathering activities in one specimen of a Commelinaceae seed phytolith (Figure F-25). No distinctive phytoliths indicative of corn or beans were observed. The burned **Panicoid** crosses and other burned phytoliths are presumably evidence of some processing activity and/or use as fuel. Some probable cucurbit phytoliths were noted in most soil samples (Table F-2 and Figures F-20 and F-21).

The Cucurbita, a genus of the *Cucurbitaceae* or gourd family, are often referred to as cucurbits. Modern members of this genus are well-known foodstuffs, including squash and pumpkin which were not native to the current research area. Some members of this family represent the earliest cultivated crop in Central America (Piperno 2006:143-4), and much of the phytolith data about cucurbits is from the tropics where early agriculture has long been a major research endeavor. Piperno noted that phytoliths from domesticated cucurbits are generally larger than those of wild specimens (ibid).

Bozarth (1992:210) reports that only one cucurbit species is native to the Great Plains region, *Cucurbita foetidissima* more commonly referred to as buffalo gourd. This species is native to the entire southwestern quarter of the United States including Texas (USDA). The mature gourd was not edible, and indeed one description of the plant states that "the arrow-shaped leaves of this sprawling member of the cucumber family emit a nauseating fetid odor that falls somewhere between smoldering tennis shoes and road-killed badger" (Jones and Cushman 2004:145). There is considerable historical evidence of native use of the buffalo gourd including "seeds ...that can be ground to mush, and the [very large] bitter roots can be processed for their starch and protein" (ibid.) or use as potions, as well as numerous medicinal applications (Foster and Hobbs 2002:103-4). Kindscher (1992:76-79), noting that the Osage referred to the plant as "big medicine," reports multiple historical medicinal uses. After stating buffalo gourd's known use as "medicines, ceremonial rattles, toys, and cleansers" the potential for producing a variety of dye colors was noted (Richards and Tyrl 2005:173, 52, 73, 115-6, 145, 163). Mature dry gourds could also have served as containers.

The generally spherical cucurbit rind phytoliths are distinctive due to their scalloped surface, and nearly all illustrations are of the best specimens of the

ideal heavily scalloped classic form. However, actually processing a small fragment of buffalo gourd to observe the total phytolith assemblage yielded a broad range of particle size and surface textures--ranging from the classical scalloped surface to a vaguely roughened surface (Sudbury 2013:747, Figure B-29). Thus, the specimens illustrated in Figures F-20 and F-21 are presented as cucurbit phytolith candidates. Buffalo gourd was indigenous to the study environment, and represents an available resource which may have been utilized by area inhabitants.

The earliest research on maize phytoliths was conducted in the tropics, where *Zea mays* or corn originated (Pearsall 1978; Piperno 1984; Piperno and Pearsall 1998). Certain phytolith morphologies that occur in several plant structures--the leaves and cobs--are diagnostic of maize. The primary diagnostic maize cob phytoliths (Bozarth 1993; Mulholland 1993) are primarily a form that has since come to be referred to as the ruffle or wavy top rondels. No such specimens were observed in any of the phytolith samples at 41LM50 or 41LM51.

The primary means of recognizing corn via leaf phytoliths is by the size of the Panicoid crosses and the overall cross assemblage. Numerous grasses contain Panicoid cross phytoliths; those in corn are generally larger than those in other grass species. Pearsall (2000:384), who in 1978 first discerned the value of the Panicoid cross short cell type size criteria while working on her Ecuador soil sample isolates, describes four cross size categories. The native grasses evaluated have primarily small crosses (< 11.4 microns), whereas corn has the full range of cross sizes including all of the large crosses which are those crosses > 16 microns; also, the total assemblage range is skewed to the larger size (ibid.).

No crosses over 16 microns were observed from 41LM50 or 41LM51, whereas they should comprise, on average, about 30 percent of the cross

sample if maize is indicated (ibid). The small crosses (Figure F-22) and medium crosses (Figure F-23) could be from maize, but in the absence of larger crosses (> 16 microns) there is no evidence for maize at the current sites. Piperno's (1984) detailed morphologic criteria for further discerning for maize phytoliths are woven into the overall detailed summary of maize phytolith identification presented by Pearsall (2000:378-392) where Piperno's eight maize variants of Panicoid crosses are illustrated. Of the eight cross variants, only form #1 is associated with maize. No type 1 crosses were present in this sample (Figures F-22 through F-24). Thus, the preponderance of evidence is that no maize is represented in this phytolith assemblage from the soils sampled from either of these sites. The high percentage of burned crosses in the sample does suggest that other grasses were being used as fuel and/or otherwise processed.

The remainder of the discussion centers on the numerical phytolith data presented in Tables F-2 through F-6. Looking at Figure F-31, compared to modern times, the sediments from 41LM50 was formed at a hotter drier time. The **Chloridoid** phytolith composition increased substantially (hot dry phytoliths) while the **Pooids (cool moist season)** went up very slightly and the **Panicoids (warm moist plants)** dropped significantly. Thus, the slightly longer cool season did not change significantly, but the summers were hotter.

Perhaps the most striking feature of this entire phytolith study is shown in the environmental data for 41LM51 (Figure F-31). Here, all three of the recognized cultural units (i.e., Toyah, Late Archaic, and Gower) opted to live at this location under very nearly the same set of environmental conditions (i.e., temperature and climate determines the botanical communities' overall composition and individual species, and thus generates the resulting phytolith signature in any given soil). This is not to say that there were not changes during the intervening times--but rather that the three snapshots provided show very uniform conditions.

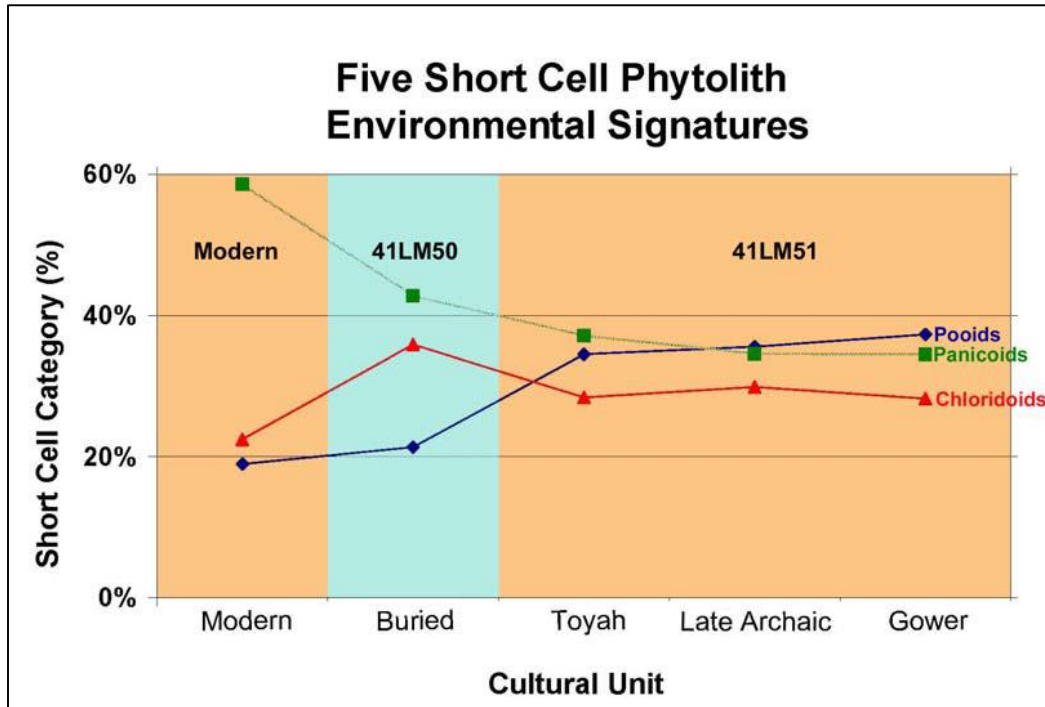


Figure F-31. Short cell environmental signatures of the five samples collected for environmental assessment.

At 41LM51 the spring and/or fall climate was significantly cooler and/or longer interval than modern day or the deposits at 41LM50, while the summers somewhat hotter and drier than modern times. But, the increased summer heat or aridity was not as extreme as that which occurred at 41LM50. Of the three phytolith short cell groupings at 41LM51, the only visible trend back to the Gower component is that the **Poooid** component continued to slightly increase (i.e., a somewhat cooler and/or longer spring and/or fall growing season). These samples are the modern surface soil, a buried surface for comparison with two features at 41LM50, and three 41LM51 soil samples for comparison with distinctive cultural debris. The five data points are in order of increasing soil depth left to right. Data comes from Table F-2.

Looking at all ten soil phytolith data signatures in Figure F-32, these basic overall environmental trends remain clearly visible, with the feature

deviations from that trend providing a potential window into site activities.

**41LM50 Feature Seasonal Interpretation, 15 And 23 Cmbs (Figure F-32):**

a) The environmental period indicated that 41LM50 (18 cmbs sample), compared to the two adjacent environmental samples (0 and 23-25 cmbs), shows a much hotter summer (**Chloridoids**), with the expected concomitant decrease in **Panicoids**, as well as a decrease in the cool season **Poooid** component.

b) The 15 and 23 cm feature samples (**Poooid**; cool season) show an increase above the 18 cmbs environmental sample as well as the modern sample which suggests possible cool season (spring and/or fall) feature usage when **Poooids** would be gathered. However their deviation is only slightly above the trend line of the adjacent environmental samples (0 and 23-25 cmbs).

c) Relative to the environmental sample (18 cmbs) both the 15 and 23 cmbs feature samples have much lower **Chloridoid** component.

d) Taken together, points b and c suggest spring/fall feature usage during an interval of much hotter summers [assuming the environmental change was linear and/or the deposits were contemporaneous--both of which are unlikely].

#### **41LM51 Feature Seasonal Interpretation, 42-47 and 45-55 Cmbs (Figure F-32):**

a) Both **Chloridoid** fractions were higher in the features (42-47 and 45-55 cmbs) than in the adjacent environmental samples (23-25 and 59-61 cmbs). This change was offset by a decrease in **Panicoid** and/or **Pooid** components.

b) The **Chloridoid** fraction in Feature 3 (42-47 cmbs) was higher than adjacent environmental samples, and was offset by a slight decrease in **Pooid** and **Panicoid** concentration. One interpretation of these fluctuations--depending on purpose of resource utilization--would be late summer/fall Feature 3 usage.

c) The **Chloridoid** fraction in Feature 4 (45-55 cmbs) was much higher than adjacent environmental samples, and was offset by a decrease in **Panicoid** concentration with no change in the relative **Pooid** fraction concentration. This would suggest mid to late summer usage by occupants utilizing **Chloridoid** plants.

d) The climatic signature of the two environmental controls are very similar.

#### **41LM51 Feature Seasonal Interpretation, 80-90 Cmbs (Figure F-32):**

a) Again, the adjacent environmental samples (Late Archaic 59-61cmbs and Early Archaic 86-88 cmbs) have very similar phytolith signatures.

b) The Early Archaic Feature 2 (**80-90 cmbs**) shows the same trends as seen in the Late Archaic Feature 4 (above)--a significant **Chloridoid**

elevation, and a significant **Panicoid** reduction--but more extreme versus the adjacent environmental samples.

c) This may indicate a late summer/fall feature usage pattern. However, at this point in time the charcoal concentration is increased [Figure F-35] so in this case it could be a winter feature. Whichever interval the feature was used, there is an increase concentration in **Pooid** and **Chloridoid** content.

It is interesting to note that three of the five samples with burned saddle [**Chloridoid**] phytolith counts were in environmental samples (18, 23-25, and 86-88 cmbs) while the two feature samples, Feature 1 at 23 cmbs in 41LM50 and Feature 2 at 80-90 cmbs in 41LM51 also had burned phytoliths (Tables F-3 through F-4).

The phytolith signature of all ten sediment samples (including the 5 environmental samples plotted in Figure F-31). The "E" designation indicates the environmental samples while "F" indicates samples associated with features. The samples are arranged in depth order left to right. Data comes from Table F-2. The burned phytolith short cell incidence (Figure F-33) shows a significant increase in burned phytoliths in two environmental samples and one feature sample. Burned phytoliths have been recognized for years (Piperno 1985; Kealhofer 1996). Boyd (2002) published a detailed study about the utility of burned phytoliths and charcoal as proxies for evaluating fire history. Although lightning-caused fires occur, two early historical uses of anthropogenic generated fire were documented: for agriculture and for helping control bison-herd movement (ibid). A synopsis of the progression of our recognition and understanding of burned phytoliths was recently published (Sudbury 2011a:13-14). Table F-3 reveals that the increase in the environmental (23-25 cmbs) sample (108-04) at 41LM51 was across the board--all three Poaceae subfamilies contributed. All three categories contributed to the burned phytolith



count at depths 18, and 23, 80-90, and 86-88 cmbs, whereas only the **Panicoid** subfamily contributed burned phytoliths at depths 0, 15, and 42-47 cmbs (Table F-3)--which have the lowest burned short cell incidence. The striking elevations in the two environmental samples may be indicative of area-wide wildfires. Intentional environmental fires by inhabitants are historically known to have been employed for several different reasons.

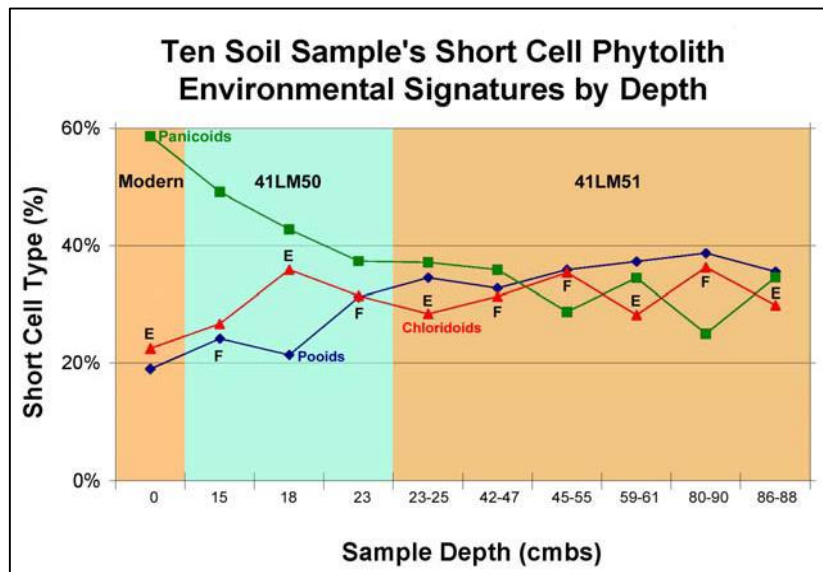
Figure F-34 looks at the incidence of "tree" phytoliths. These phytoliths are nondescript to species, but are generally felt to originate from trees (see examples in Figure F-29); thus, they are significant countable entities.

As these two sites are on a waterway, the presence of trees is not surprising. In looking at the environmental trend over time, the incidence of tree phytoliths increases going back in time. It may not be simple coincidence that two of the three highest tree count environmental samples correlate with the two highest burned phytolith incidence (Figures F-33 through F-34, Table F-4). It is not known if the environmental trees are evidence of resource use, or simply an indication of availability.

Similarly, the charcoal particle count also increased throughout most of the depth tested (Figure F-35).

Figure F-36 shows two particle ratios plotted on a log scale to help enhance data visibility. The green plot shows that the ratio of charcoal particles to tree phytoliths varied significantly for the first six samples with the tree phytolith counts at 41LM50 dropping at the same time the **Chloridoid** fraction increased (Figure F-32), with tree phytoliths outnumbering charcoal particles from 45-55 cmbs downward. There was much less variation in the ratio of burned short cell phytoliths to tree phytoliths (blue plot), although the tree phytoliths normally were found to be more abundant.

The green squares are ratios of observed charcoal particles to observed tree phytoliths. The blue diamonds are the ratios of the burned percent of short cells to the total number of tree phytoliths. This data is presented as a log plot to enable both sets of data to be clearly visible with one scale. The "E" designation indicates environmental samples while "F" indicates samples associated with features. Data comes from Tables F-2 and F-6.



**Figure F-32. Short cell feature and environmental signatures.**

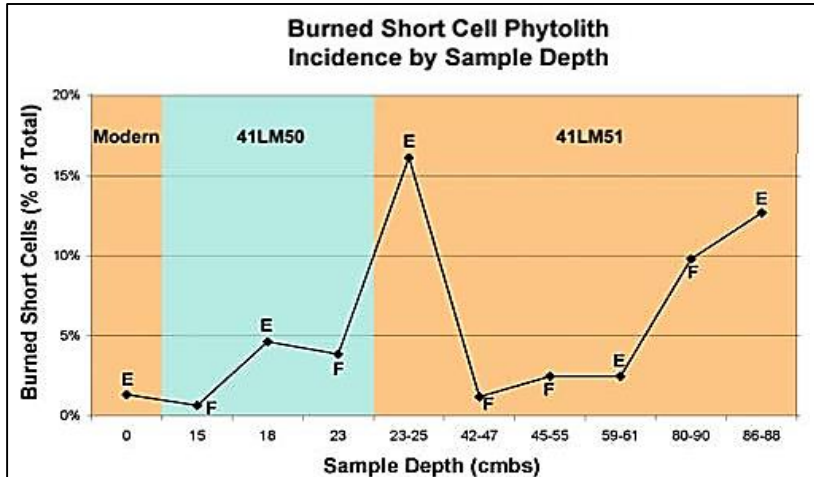


Figure F-33. Burned short cell phytolith incidence (percent of total short cells counted) by sample depth. Data comes from Table F-4.

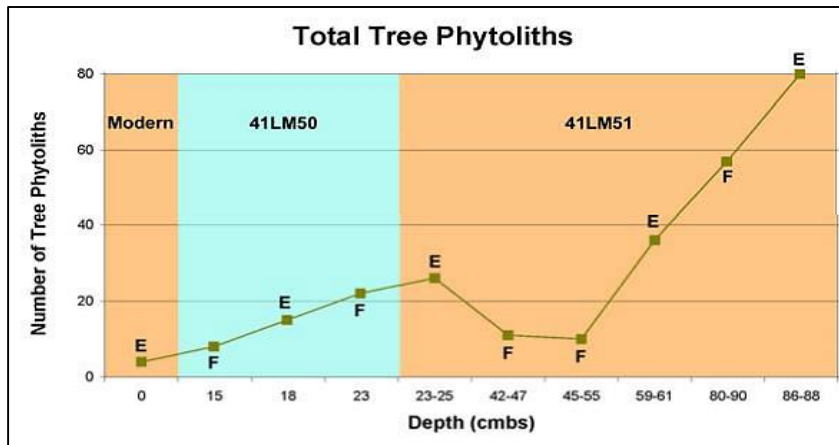


Figure F-34. Total tree phytoliths by depth. The "E" designation indicates environmental samples while "F" indicates samples associated with features. Data comes from Table F-2.

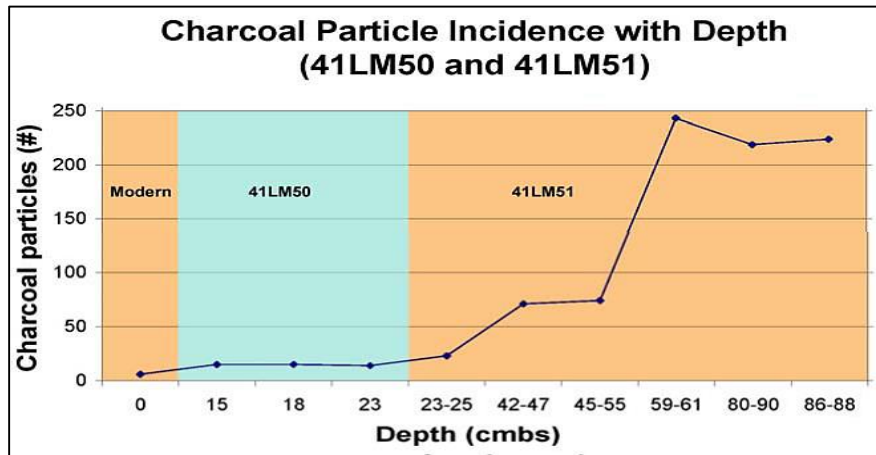


Figure F-35. Incidence of charcoal particles in the soil samples (total particles counted in microscopic fields scanned). Data comes from Table F-2.

The final graphic concentrates on the variations observed in the **Chloridoid** phytolith fraction (i.e., "saddle" phytoliths) as first reported elsewhere (Sudbury 2011a:172-179). Even though the **Chloridoids** are all "saddle" type morphologic form, some specimens are taller than they are wide, and vice versa. Different species of plants produce different saddle morphologies. This variation was determined to have specific correlation, and a good way to visualize and interpret this difference is shown in Figure F-37. The ratio of the tall:squat saddle forms is plotted on the x-axis, and the **Chloridoid** per cent of the total short cell assemblage is plotted on the y-axis.

The three color-highlighted areas are three different riparian settings for which the entire soil profile have been analyzed. The green area, at Carnegie Canyon in Caddo County, Oklahoma, is a fairly tight cluster. This is from a very small short stream with a very small drainage area, and it has a reasonably tight cluster or distribution over the last several thousand years. The tan oval is from an older soil profile sequence in northeastern Oklahoma (mid to early Holocene) along a small stream with limited drainage which actually had

a saddle ratio over 14 in one sample (Sudbury 2011b:20).

The pale yellow oval, somewhat diagonal in the middle of the graph, is from a larger stream in northeast Oklahoma (Sudbury 2011a). This particular site's sample yielded a relatively large vertical and horizontal scatter in the **Chloridoid** data.

The interpretation of this saddle data is that a change in vertical position is primarily indicative of a change in temperature (with possibly a small moisture component), whereas a horizontal change represents a change in species predominance (community balance) on the landscape due primarily to moisture-related issues (as well as other possible soil-related issues; Sudbury 2011a:178-179).

The diamonds are the 41LM50 and 41LM51 samples with green representing the environmental ("E") samples and the red representing the feature samples ("F"). The open red circles show the samples from 41RB112 on the same plot [several other red circles were off scale to the right in the same percent range]. The black squares are

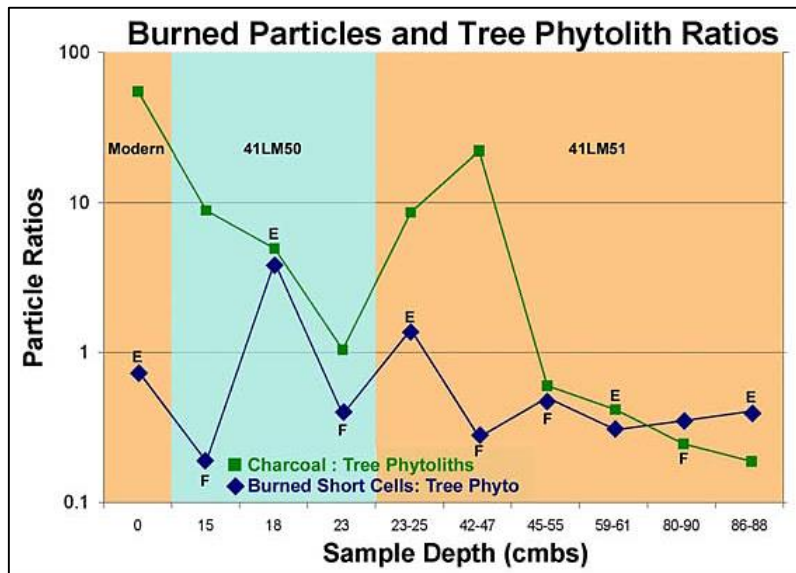


Figure F-36. Log plot of burned particles and tree phytolith ratios.



previously analyzed upland and riparian sample A horizons (and a paleosol). The three color ovals (yellow, green, and tan) show the general distribution the data points for the saddle data from the entire soil profiles of these riparian settings.

Thus, the cluster represented by the green assemblage is fairly tight with slight variation in temperature and species change (i.e., moisture; this site is well within the last half of the Holocene). All of the Opossum Creek samples (brown oval) predated 4000 B.P., and show a huge ratio range (i.e., species variability over time [values >14 occurred]), but relatively minimal thermal variation. The yellow oval shows a concomitant moisture/species and temperature variation over time. The upland prairie control sites (shown by black squares) are predominantly grasses, whereas the riparian settings have much more intrinsic

species variation due to their location on the landscape. The two composite Manning Tallgrass Prairie samples were taken from different nearby locations in the same never cultivated meadow--each point is an average of 25 separate samples taken from within a 50 meter circle--and clearly show that some species variation/range is normal due to moisture variation (and other soil parameters) even as the temperature irrefutably remained constant.

The open red circles show the data from the Long View site along a major stream in Roberts County, Texas panhandle (Sudbury 2013). The four feature samples on the graph (plus the two off scale right) show minimal thermal variation (y-axis), but significant moisture/species variation (x-axis). The fifth sample shown (< 40 percent)--

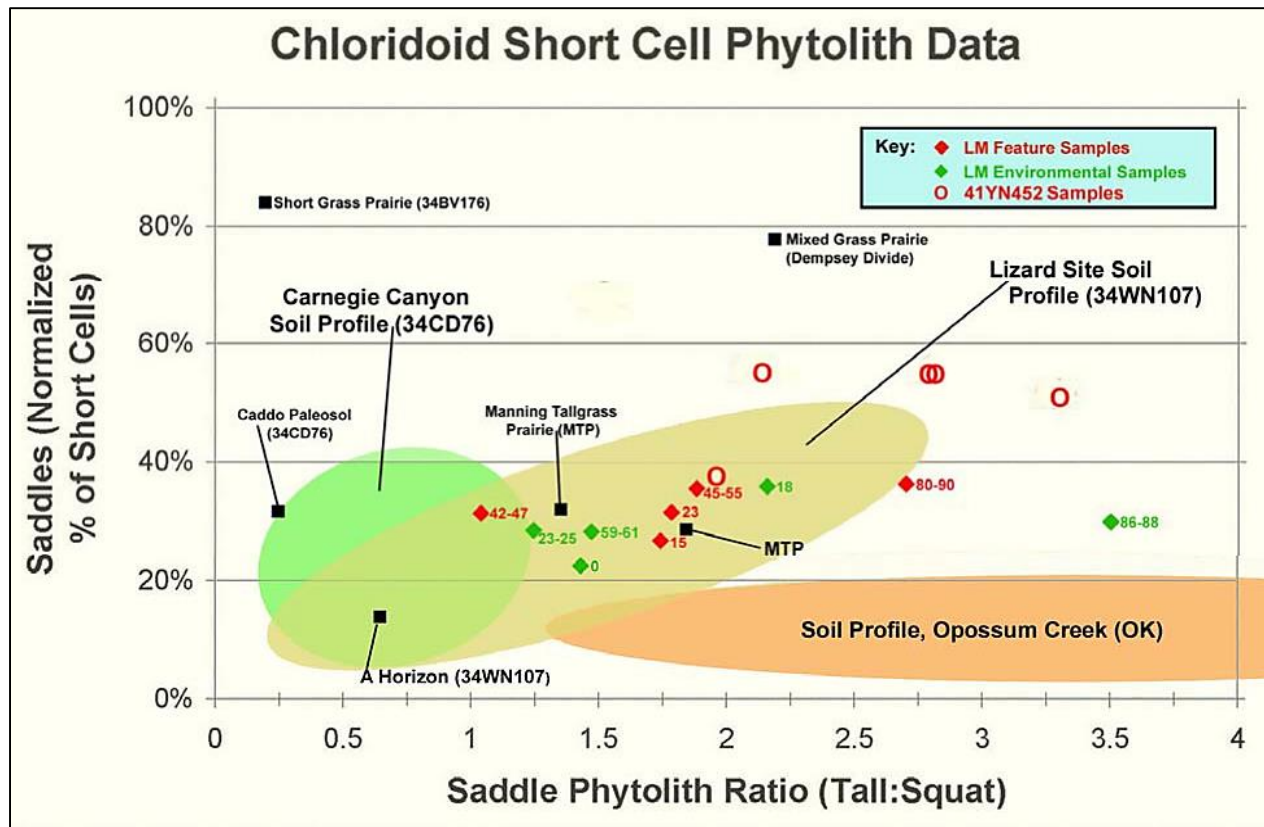


Figure F-37. Chloridoid short cell phytolith data.

had more thermal variation relative to the feature samples, but had a similar moisture/species ratio to one of the feature samples.

For the five feature samples, the current Lampasas County sites show a very tight cluster for the most recent samples at 41LM50 (15 and 23 cmbs) suggesting that soil conditions did not change although the effective temperature may have increased slightly. However, there is significant species variation among the other three feature samples from 41LM51 (42-47, 45-55, and 80-90 cmbs [due to soil conditions]) with minimal thermal variation (y-axis variation) among all five samples. Interestingly, three environmental samples at 41LM51 cluster very tightly (0, 23-25, 59-61 cmbs) indicating a nearly identical relative **Chloridoid** signature at those times, with 18 cmbs showing some moisture/species variability and more thermal variability than any of the other four environmental samples. The fifth sample (86-88 cmbs at 41LM51) has the same temperature rating as the cluster of three, but much more species variation suggesting plant species migration.

There are several potential weaknesses in this overall data interpretation. First, the relative depths used as the measure of comparison are not necessarily linear (i.e., the times they represent are not necessarily set to the same intervals). However, at least within a given site, the depths are in chronological order so it is felt like the interpretations presented have merit. Second is the problem of potential phytolith dissolution at 41LM51 due to soil parameter and chemistry issues. The basic soil pH and the observed weathered bulliform phytoliths suggest some biogenic dissolution has occurred at 41LM51. With smaller mass, short cell phytoliths with a high surface to mass ratio and much smaller size would be more prone to complete dissolution than the bulliform phytoliths (which have a relatively low surface to mass ratio). Even so, all short cell phytoliths potentially would suffer the same

physical predicament, so it is possible that dissolution would not be selective between short cell forms and thus the relative numbers measured in this study would be viable. The bulliform: short cell ratio may be altered, but the normalized short cell percent should be stable. It is also possible that dissolution was not universal; the obvious formation of carbonates around roots may indicate that portions of the soil (such as root zones and ped surfaces) may have been more or less prone to pH and particle dissolution issues than other soil locations.

## **F.7 CONCLUSIONS**

A complete suite of biogenic silica was isolated from five discrete environmental samples and five feature-related samples from two archeological sites (41LM50 and 41LM51) located along the small Lynch Creek in Lampasas County, in central Texas. At the time of the earliest environmental sample (86-88 cmbs at the time of the Gower occupation at ca. 6750 B.P. in 41LM51), the sole identifiable freshwater sponge gemmosclere from 41LM51 indicates that the water conditions were slightly acidic clear still water with a low mineral and organic content. Although the gemmosclere appears to be pristine, many of the broken spicules from the entire profile showed considerable abrasion suggesting some periods of turbulent stream activity during the Holocene.

At 41LM50, the sole Late Prehistoric environmental sample (ca. 200 to 450 B.P. at 18 cmbs) is significantly different than the adjacent 41LM51 environmental samples (0 and 23-25 cmbs) suggesting a major climatic change during this interval. The environmental sample short cell components deviate significantly from trend lines between the short cell distributions of the two adjacent environmental samples. Relative to the designated internal control (18 cmbs), both burned rock Features 1 and 2 (at 15 and 23 cmbs) have a significant **Pooid** (cool season) increase and a major offsetting decrease in **Chloridoid** fraction.

Yet, both feature **Chloridoid** and **Pooid** values are above their respective trend lines between the adjacent environmental samples (0 and 23-25 cmbs). The **Panicoids** decreased down profile. The data set indicates very hot summers, with enhanced spring and/or fall activity related to specific feature usage. The Late Prehistoric environmental sample results from 41LM50 show a much hotter period than modern times with less cool season change and more aridity in the summer.

At 41LM51, the Late Archaic burned rock Feature 4 clearly shows an enhanced concentration of **Chloridoid** phytoliths (hot dry season) and a major decrease in **Panicoids** (warm moist season) associated with the feature compared to the two bracketing environmental samples with the **Pooid** concentration remaining stable (Figure F-32). This trend may be an indicative signature of gathering **Chloridoid** grasses in the late summer or fall after a difficult hot dry spell. Burned rock Feature 2 representing the Gower period (ca. 6750 B.P.) shows an even more exaggerated instance of the same changes as Feature 4, with the **Pooid** concentration also increasing slightly suggesting the feature may have been in use well into the fall. Late Archaic burned rock Feature 3 shows the same general albeit weaker trend in the **Chloridoid** fraction; unlike the other two feature samples. Feature 4 has a noticeable decline in the **Pooid** fraction and essentially no change in the **Panicoid** component which may indicate summer feature usage.

The overall environmental phytolith signature shows the three occupation periods sampled at 41LM51 (Late Prehistoric, Late Archaic, and Early Archaic) to have had remarkably similar environmental conditions at the time of occupation with a longer cooler spring and/or fall seasons (C<sub>3</sub> grass intervals) and a warmer summer interval with less moisture than modern day.

## F.8 REFERENCES

- Boyd, M.  
2002 Identification of Anthropogenic Burning in the Paleoecological Record of the Northern Prairies: A New Approach. *Annals of the Association of American Geographers* 92:471-487.
- Bozarth, S.  
1992 Classification of Opal Phytoliths Formed in Selected Dicotyledons Native to the Great Plains. In *Phytolith Systematics: Emerging Issues*, edited by G. Rapp, Jr. and S. C. Mulholland, pp. 193-214. Plenum Press, New York.
- Davies, P.  
2008 *SNAILS Archaeology and Landscape Change*. Oxbow Books, Oxford. Harrison, F. W.
- 1974 Sponges (Porifera:Spongillidae). In *Pollution Ecology of Freshwater Invertebrates*. Edited by C. H. Hart, Jr., and S. L. H. Fuller, pp. 29-66. Academic Press, New York.
- Foster, S. and R. C. Hobbs  
2002 *A Western Medicinal Plants and Herbs*. The Peterson Field Guide Series. Houghton Mifflin Company, Boston.
- Harrison, F. W.  
1974 Sponges (Porifera:Spongillidae). In *Pollution Ecology of Freshwater Invertebrates*, edited by C. W. Hart, Jr., and S. L. H. Fuller, pp. 29-66. Academic Press, New York.
- Jones, S. R. and R. C. Cushman  
2004 *A Field Guide to the North American Prairie*. The Peterson Field Guide Series. Houghton Mifflin Company, Boston.

- Kealhofer, L.  
1996 The Human Environment During the Terminal Pleistocene and Holocene in Northeastern Thailand: Phytolith Evidence from Lake Kumphawapi. *Asian Perspectives* 35:229-254.
- Kindscher, K.  
1992 *Medicinal Wild Plants of the Prairie An Ethnobotanical Guide*. University Press of Kansas, Lawrence.
- Monger, H. C.  
2002 Pedogenic carbonate: links between biotic and abiotic CaCO<sub>3</sub>. p. 897-1 to 897-9. In *Transactions of the 17th World Congress of Soil Science*, Bangkok, Thailand. <http://clic.cses.vt.edu/soils/write/papers%20and%20reports/Nina%20read%20this.pdf> (accessed 8-22-13).
- Pearsall, D. M.  
1978 Phytolith Analysis of Archaeological Soils: Evidence for Maize Cultivation in Formative Ecuador. *Science* 199:177-178.  
  
2000 *Paleoethnobotany: A Handbook on Procedures*. 2<sup>nd</sup> Ed. Academic Press, San Diego.
- Piperno, D. R.  
1984 A Comparison and Differentiation of Phytoliths from Maize and Wild Grasses: Use of Morphological Criteria. *American Antiquity* 49:361-383.  
  
1988 *Phytolith Analysis: An Archaeological and Geological Perspective*. Academic Press, San Diego.  
  
2006 *Phytoliths A Comprehensive Guide for Archaeologists and Paleoecologists*. AltaMira Press, New York.
- Piperno, D. R. and D. M. Pearsall  
1998 *The Origins of Agriculture in the Lowland Neotropics*. Academic Press, San Diego.
- Reiswig, H. M, T. M. Frost, and A. Ricciardi  
2008 "Porifera". In *Ecology and Classification of North American Freshwater Invertebrates*, edited by J. H. Thorp and A. P. Covich, pp. 91-123. Academic Press, New York.
- Richards, L. and R. J. Tyrl  
2005 *Dyes from American Native Plants: A Practical Guide*. Timber Press, Portland.
- Sudbury, J. B.  
2007 Sewright Site (39FA1603) Phytolith Analysis. J. S. Enterprises Project Report 2007-2. Manuscript in possession of the author.  
  
2009 Phytoliths from Features at Two Gunnison County Archaeological Sites (5GN2404 and 5GN2262) [Appendix C]. In *Archaeological Data Recovery At Six Sites Along The Blue Mesa-Skito 115-Kv Transmission Line, Gunnison County, Colorado*, by S. Moore and J. Firor. Western Area Power Administration Contract Report.
- 2011a *Quantitative Phytolith Analysis: A Working Example from Modern Prairie Soils and Buried Holocene A Horizons*. Phytolith Press.  
  
2011b *Biogenic Silica from Opossum Creek Soils, Nowata County, Oklahoma, USA*. Phytolith Press.  
  
2011c Appendix E. Phytoliths Present in a Buried Soil and Select Cultural Features at 41YN452. In *Root-Be-Gone (41YN452): Data Recovery of Late Archaic*

- Components in Young County, Texas, Volume 2*, by J. M. Quigg, P. M. Matchen, C. D. Frederick, and R. A. Ricklis, pp. 449-488. Texas Department of Transportation Environmental Affairs Division, Archeological Studies Program, Report No. 135. Austin, Texas.
- 2013 Appendix B 41RB112 Sediment Sample Phytolith Analysis. In *Long View (41RB112): Data Recovery of Two Plains Village Components in Roberts County, Texas, Volumes I and II*, by J. M. Quigg, P. M. Matchen, C. D. Frederick, R. A. Ricklis, B. Gregory, D. Maki, and M. Bateman. Texas Department of Transportation, Environmental Affairs Division, Archeological Studies Program, Report No. 147 and TRC Technical Report No. 174542 and 46557, TRC Environmental Corporation, Austin.
- 2013 United States Department Agriculture (UADA) *Cucurbita foetidissima* Kunth Missouri gourd.  
[http://plants.usda.gov/core/profile?symbol=CUFO&mapType=nativity&photoID=cufo\\_001\\_ahp.tif](http://plants.usda.gov/core/profile?symbol=CUFO&mapType=nativity&photoID=cufo_001_ahp.tif) (accessed 8-28-13).
- Yost, C.  
2011 "Commelinaceae see phytoliths in North America: Recovery from archaeological and paleoecological contexts, and comparison to modern reference material." Paper presented at the 8<sup>th</sup> International Meeting on Phytolith Research, Estes Park, Colorado, (September 17)

## **APPENDIX G**

# **TXDOT CHIPPED STONE ANALYTICAL PROTOCOL, VERSION 2.1**

Prepared by:

Texas Department of Transportation  
Environmental Affairs Division  
Archeological Studies Program

2010

*This page intentionally left blank.*

## CHIPPED STONE ANALYTICAL PROTOCOL

Texas Department of Transportation

### G.1 TXDOT ARCHEOLOGICAL STUDIES PROGRAM

This protocol specifies the observations to be made with respect to chipped stone artifacts during fieldwork and analysis. It is TxDOT's position that data should be collected with problem-oriented research in mind, but that is not to say that it needs to be used in the context of the study that it is collected in - just that it needs to be systematically reported so that future researchers have access to the data for the purposes of developing innovative research designs. The specific observations included within this protocol have been selected because they have proven valuable for addressing important questions of prehistory, and because they can be feasibly accomplished in most laboratory settings within a reasonable time frame. The implementation of this protocol will not undermine the collection of additional data so long as the need for additional data can be justified with respect to specific research needs. We recognize that reasonable disagreement is possible with respect to those choices.

The following discussion of procedures is designed as a guide for using the data coding key that is part of the TxDOT chipped stone protocol. Data coding is important to the process of recording standardized observations within the proposed state-wide database that will facilitate inter-site comparisons and allow researchers to more readily address regional-scale research questions. It is TxDOT's intent that this protocol be used when analyzing any form of chipped stone tool or core. This portion of the protocol does not address the analysis of groundstone tools or chipped stone non-tools (e.g. symbolic forms).

### G.2 TAXONOMY

The artifact taxonomy presented here has been designed as a means to record various levels of analytical data for each specimen, and to move beyond a strict reliance on static artifact names and types. It is hoped that this taxonomy will help identify technological traditions and preferences of technique within and between groups, landscapes, regions, and periods. Taxonomic classification of stone tools will also provide the eventual database with greater analytical potential.

#### 1. Technology

Technology, as used here, relates to the suite of techniques used to produce a lithic implement. The primary distinction at this level is between (1) chipped stone, and (2) groundstone, although minor categories may be considered. This will be used to separate lithic artifacts at the broadest analytical level. TxDOT anticipates the development of a groundstone protocol in 2009.

#### 2. Group

At the next lower taxonomic level, lithic objects classified as chipped stone (non-debitage) may be separated into two distinct groups. The first group is *Tools*, and includes objects that represent or were intended for (in the case of performs) direct functionality. The second group is *Non-tools*, representing objects of indirect functionality (ex. cores), or objects of an instructional, symbolic or artistic nature (ex. Early Archaic multi-notched lithics). For the purposes of this protocol, only those artifacts grouped as chipped stone tools are considered.

#### 3. Subgroup

Tool subgroup identifies the primary technique of manufacture. Chipped stone tools are classified into one of three subgroups: (1) simple detachment-based; (2) complex detachment-based; and (3) core-based. Detachment-based tools are derivative of larger cores. Simple detachment-based tools are classified as either blades or flakes, and are used



with modest to no modification following detachment. Complex detachment-based tools undergo substantial modification prior to use. Such tools most commonly originate as macro-flakes or macro-blades detached from a sizable core. The form is then reduced through bifacial or unifacial percussion and, unlike simple detachment-based tools, proceeds through several identifiable reduction stages prior to use. Core-based tools are constructed from material cores (most often in the form of tabular or nodular cobbles) rather than detachments. Such tools are reduced through bifacial or unifacial percussion and proceed through several identifiable reduction stages prior to use. Differentiating between core-based and complex detachment-based tools may not be possible. Complex detachment-based tools can often only be distinguished from core-based tools when they retain characteristics of their origin. These may include a remnant bulb of percussion, striking platform, or (more typically) identifiable ventral surface.

#### **4. Class**

A tool class identifies the general form of the tool with implicit information relevant to understanding the techniques of manufacture. For simple detachment-based tools, classes include flakes and blades. For both complex detachment-based tools and core-based tools, classes include bifaces and non-bifaces.

#### **5. Subclass**

The subclass of a tool provides additional information with respect to its class, often related to the degree to which the producer adhered to a predetermined manufacturing template. A subclass also encodes implicit information relevant to understanding the degree of expediency with which the tool was crafted. Tools classified as either flakes and blades are sub-classified as either modified or unmodified. Such tools are sub-classified as modified when additional stages of manufacture are required following their initial detachment

prior to their use. Sequent flake unifactes, end scrapers, drills, and backed blades are a few examples of modified simple detachment-based tools.

Tools classified as either bifaces or non-bifaces are sub-classified as either formal or informal. If tools fit within a standardized, pervasive, recognizable morphology, they are considered formal as the producer is presumed to have been following a traditional manufacturing template. Unique tool forms that (typically) appear more expedient in design are considered informal.

#### **6. Type**

A tool's type identifies aspects of its use. Complex detachment-based and core-based tools should be typed according to their function. Function should be determined through use-wear analysis using the methods and observations outlined below. Some examples of biface tool types include projectiles, adzes, choppers, and knives. Examples of non-biface tool types include scrapers, adzes, and gouges.

Simple detachment-based tools sub-classified as modified flakes should also be typed according to their function (ex. burin, drill, graver, etc.). Simple detachment-based tools sub-classified as unmodified flakes should only be typed as expedient. Simple detachment-based tools sub-classified as unmodified blades should be typed according to their morphology. Common unmodified blade types include dihedral and polyhedral varieties. Simple detachment-based tools sub-classified as modified blades should be typed according to modification form (ex. backed, stemmed, etc.).

#### **7. Subtype / Identity**

The identity of a tool form (its subtype) corresponds to how it is commonly identified within the classical typological system. Thus, a projectile may be identified as Angostura, Bell, Clovis, Dalton, Ensor, etc. For tools classified as

flakes and blades, the appropriate identity will most often be “not applicable” (an exception would be a Clovis blade).

### G.3 METRIC INFORMATION

#### 8. Max Length

Record the maximum observed length of the tool form to the nearest whole millimeter. Do not project or estimate unrepresented portions of the tool form. Using calipers, take this measurement directly from the tool.

#### 9. Max Width

Record the maximum observed width of the tool form to the nearest whole millimeter. Do not project or estimate unrepresented portions of the tool form. Using calipers, take this measurement directly from the tool.

#### 10. Max Thickness

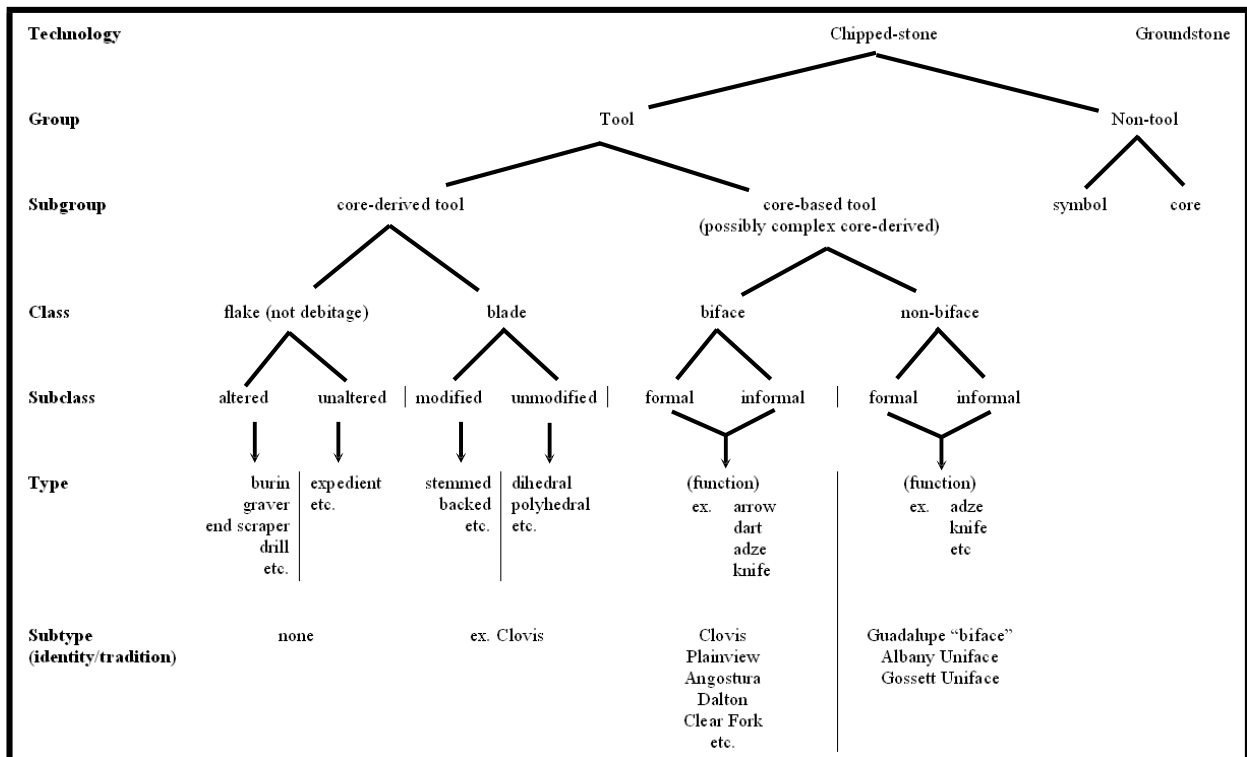
Record the maximum observed thickness of the tool form to the nearest whole millimeter. Do not project or estimate unrepresented portions of the tool form. Using calipers, take this measurement directly from the tool.

#### 11. Weight

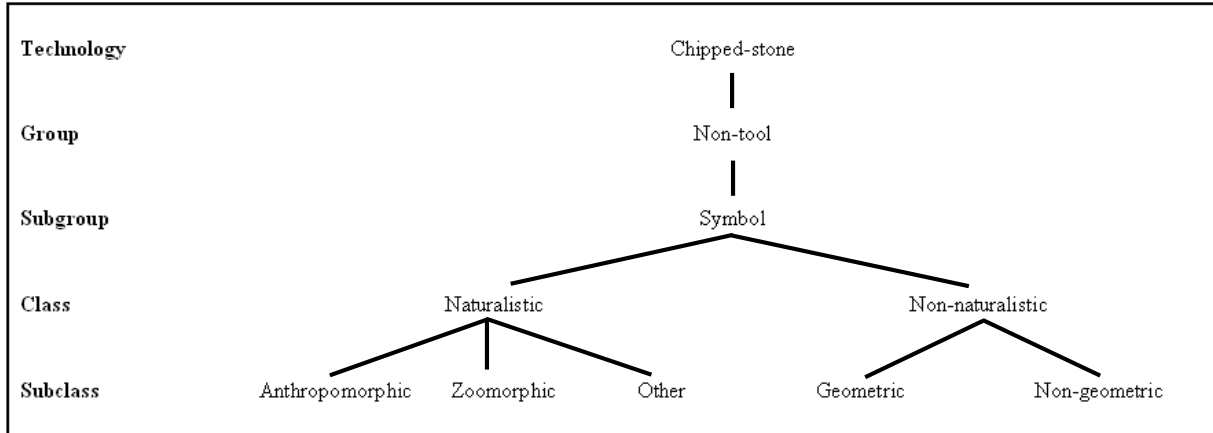
Record the weight of the tool to the nearest whole gram.

#### 12. Edge Angle

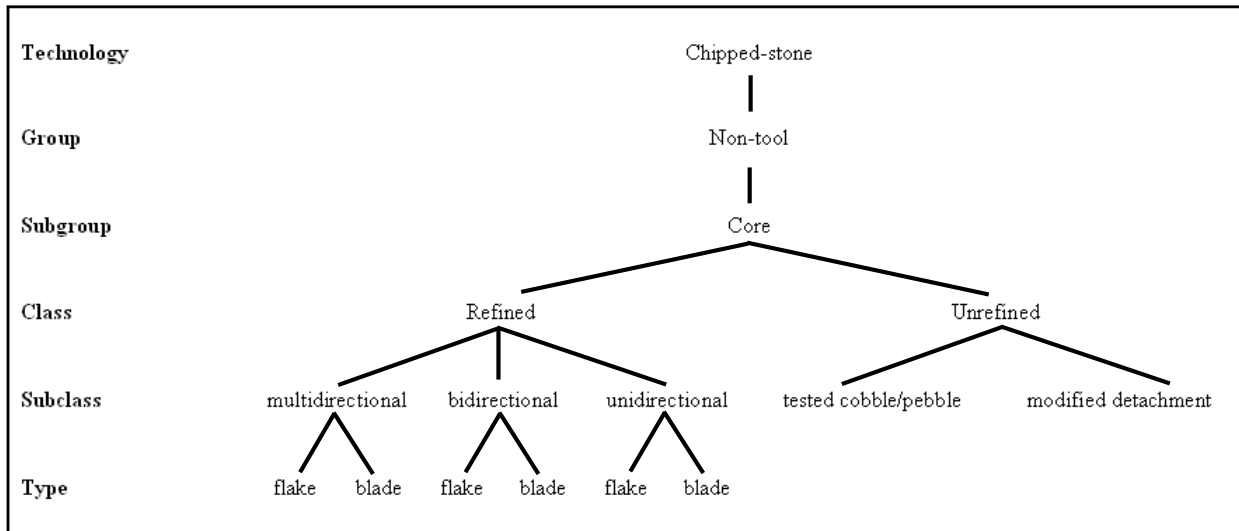
The edge angle of the tool should be recorded as an average measure along the used margin of the form. This should be recorded to the nearest 5° interval. Measurements should be made using a goniometer and recorded directly from the tool. Some extrapolation is acceptable where the edge has been blunted from use and the original angle can be determined.



**Figure G-1. Artifact taxonomy for chipped stone tools based on technological attributes and reduction characteristics.**

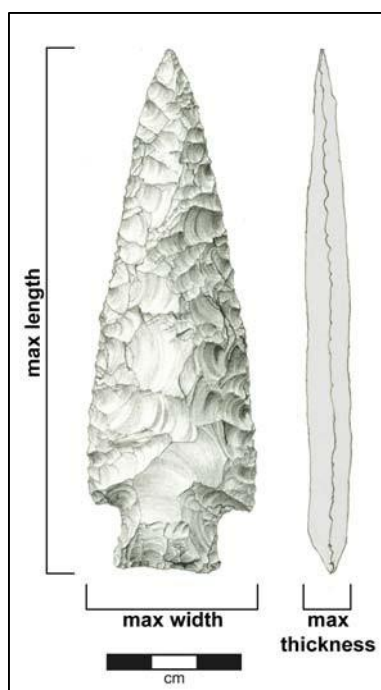


**Figure G-2. Artifact taxonomy for chipped stone objects with primarily non-utilitarian, symbolic purpose.**



**Figure G-3. Taxonomy for chipped stone cores.**

These are not tools, but rather the objective piece from which tool forms are extracted.

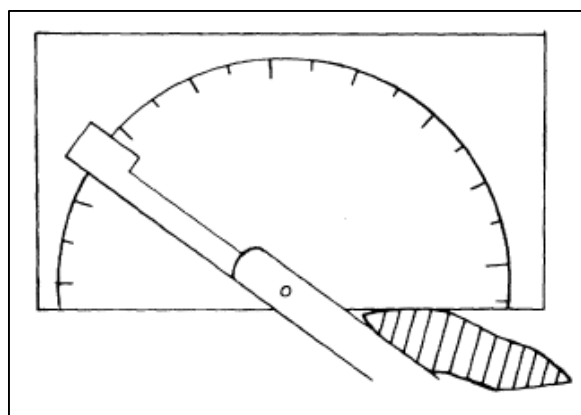


**Figure G-4. Metric measurements recorded directly from tool.**

## G.4 ATTRIBUTES

### 13. Stage

Linear reduction models assist in determining the stage of manufacture an artifact reached within an idealized trajectory. Linear reduction models provide a framework for understanding the functional and behavioral relationships among related sets of artifacts (Collins 1975; Goode 2002; Patterson 1977, Shafer 1983, 1985; Sollberger 1977; Tsirk 1979), and are typically based on theoretical abstractions or on experimental replication (Crabtree 1966). Classifying tools in accordance with a linear reduction scheme allows for a more precise study of manufacturing concerns, and it provides a conceptual model for determining the degree of morphologic variation that finished trajectories may be expected to exhibit.



**Figure G-5. Edge angle can be recorded with the use of a goniometer.**

As the exact angle may vary across the length of the use edge, it is sufficient to record edge angle to the nearest 5° increment.

When assessing trait or design variability, it will be most productive to compare finished tool forms that have not been extensively remodeled through recycling efforts. The criteria for determining stage of manufacture used in this work closely follow that of Black et al. (1997).

Five stages in the life cycle trajectory of tools are recognized in this protocol: (1) initial package reduction, (2) blank preparation, (3) preform shaping and thinning, (4) final edge trimming and sharpening, and (5) rejuvenated forms. Assessing manufacturing stage is not a wholly objective enterprise (Goode 2002). Lithic reduction is a linear process, and its separation into discrete units of activity is necessarily subjective. Also, the fragmentary nature of some artifacts, the retention of trace amounts of surface cortex on finished forms, and variability in production patterns due to raw material variability and individual skill all contribute to the occasional difficulty in assigning production stage. However, observing this process in stepwise fashion provides a useful proxy measure for detecting potentially important

variations in the organization of lithic resource exploitation.

The first stage of the linear reduction model, *initial package reduction*, reflects the beginning steps of tool manufacture and includes preliminary reduction efforts such as cortex removal, mass thinning, and initial shaping. At this stage, objective pieces typically retain some cortex on one or both faces and reduction is dominated by hard-hammer percussion. Tool forms in their initial production stage are generally irregular in outline, exhibit unrefined edges, and do not provide an indication of the intended manufacturing trajectory. However, tools may be employed as crude “choppers” even at this early stage (Goode 2002: 36). Most expedient tool forms will be assigned to this reduction stage.

The second category, *blank preparation*, is characterized by the production of a less generalized form with a limited set of possible final trajectories. Tool forms in this stage of manufacture, called “blanks” (Crabtree 1972), typically exhibit little if any cortex, although completed tools may exhibit traces of cortex on occasion. As blanks, tools receive further reduction of mass through thinning, which is accomplished with some hard-hammer, but primarily soft-hammer percussion. Blanks require refinement of lateral margins, which may appear sinuous on bifacial forms. Incipient stems may be initially observed at this stage.

The third category, *preform shaping and thinning*, is characterized by the artisan’s full commitment toward a single or very limited number of morphological forms, producing what is commonly called a “preform” (Crabtree 1972b). Preforms exhibit a significant reduction in thickness when compared to blanks, and soft-hammers are used almost exclusively for purposes of reduction. Cortex is rare on these late stage forms. Artifacts categorized as performs approximate their final design and generally lack

only refinement of lateral edges and minor facial thinning. Edges are nearly straight and exhibit minor sinuosity. This is the final stage of production to use direct percussion.

The fourth category, *final edge trimming and sharpening*, includes artifacts that are very near or have reached the end stage of their manufacture. Tools within their final production stage require minor reduction along their margins, which is accomplished exclusively through pressure flaking and indirect percussion. Notching, edge grinding, and final stem preparation are completed at this stage. Artifacts having reached their end stage presumably represent tools that were discarded (often due to breakage), cached, lost, or otherwise abandoned. Finished forms require no additional production efforts, and commonly exhibit use-related edge modification (use-wear). Edges have not been remodeled through refurbishing efforts.

The final category, *rejuvenated forms*, describes artifacts that exhibit pronounced edge retouch or remodeling, a marked reduction in size, or evidence of adaptation to a secondary production trajectory in response to failure or discontinuation of the initial tool form. Tool rejuvenation and other forms of recycling provide important information regarding the perceived value of the resource.

00. [Indeterminate]
01. [Initial Reduction]
02. [Blank]
03. [Preform]
04. [Final Stage]
05. [Rejuvenated]

These can be found within the TxDOT Chipped Stone Analytical protocol. However, it should be noted that “fractured segments” will often be identified as belonging to a perform of finished tool, and should be categorized appropriately. The final category, “recycled flakes,” would be difficult to identify as deriving from an original formal tool in most instances, and many objects of

this character would be included in the lithic assemblage as debitage. Such objects should only be identified as rejuvenated forms when the analyst is certain that a precursor form existed.

In the reduction sequence to the right, "stage one: blank" and "stage two: edged biface" each would be classified under Stage 2 (blank preparation) of the TxDOT Chipped Stone Analytical protocol. Similarly, "stage three: thinned biface" and "stage four: perform" would be classified as Stage 3 (perform shaping and thinning) under the TxDOT Chipped Stone Analytical protocol. The "stage five" shown here relates to Stage 4 of the TxDOT protocol.

#### **14. Portion**

A significant number of tools are recovered in a fragmentary state and it is important to record the portion represented. Identify partial forms as "fragments" when too little of the tool remains to determine what part of the tool is represented. As it is occasionally difficult to determine whether a piece corresponded to a proximal or distal segment, even when it was clear that one or the other is represented, an "indeterminate" category has been included.

- 00. [Indeterminate]
- 01. [Complete]
- 02. [Distal]
- 03. [Distal-medial]
- 04. [Medial]
- 05. [Proximal-medial]
- 06. [Proximal]
- 07. [Lateral edges missing]
- 08. [Fragment]
- 09. [Barb / shoulder]
- 10. [Ear / tang]
- 11. [Stem]

#### **15. Failure / Discard**

Determining the reason why a particular tool form was discarded is seldom a straightforward

endeavor. Oftentimes such a determination cannot be made at all. However, where a cause of discard can be determined, valuable insights regarding production specialization and standardization, raw material conservation, use context, and cultural ideology may be gleaned.

The context of tool discard can be identified as production-related, use-related, and incidental. Production-related discard occurs when tools are discarded during manufacture as the result of technical mistakes or material deficiencies. Use-related discard can result from stress or impact fractures, excessive dulling, material exhaustion, use-loss, or caching. Tool forms may also be lost unintentionally. Each mode of discard will have distinct implications for the likelihood of artifact recovery.

Several factors are also known to complicate determinations of discard cause. Secondary tool modification and material recycling may complicate determinations of failure, as can patina development. Excessive thermal alteration can also present an obstacle for assessing the probable cause of original discard as it is often difficult to determine the point at which the object was altered. Artifacts can be subjected to excessive heat following their discard, as when affected by modern or ancient surface fires. The over-firing of raw material blanks or preforms may also have contributed to fire-damage.

#### ***Production-related Discard***

Several authors have previously described snap or bending fractures (Crabtree 1972:60; Whittaker 1994:213; and Tsirk 1979:84). This fracture results when the lithic material is subjected to bending forces that exceed the material's elastic limits. Snap fractures often occur during tool production due to the knapper's failure to provide the objective piece with adequate support as it is reduced. In so doing, vibrations radiate throughout the tool form with each percussive strike, causing a fracture at the point where the elasticity of the

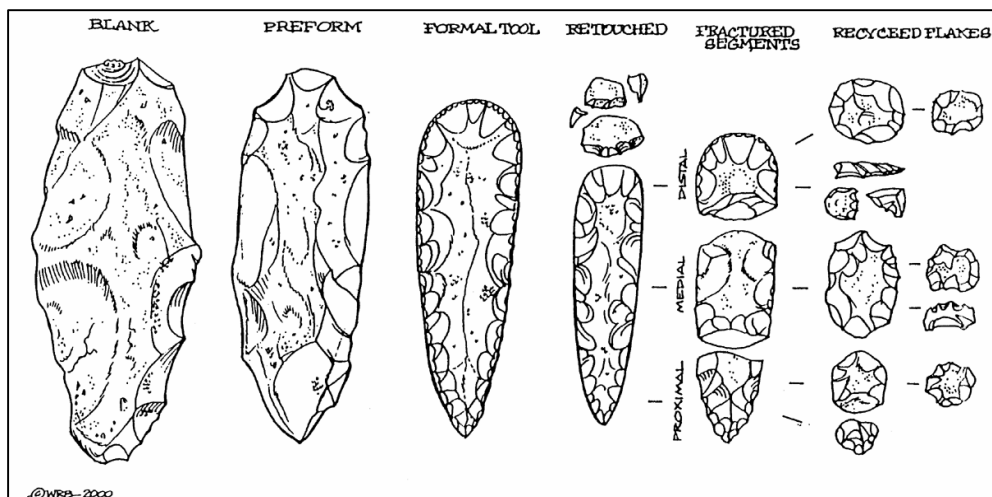


Figure G-6. In the illustration above, "retouched" and "fractured segments" are generally represented by Stage 5 (rejuvenated forms).

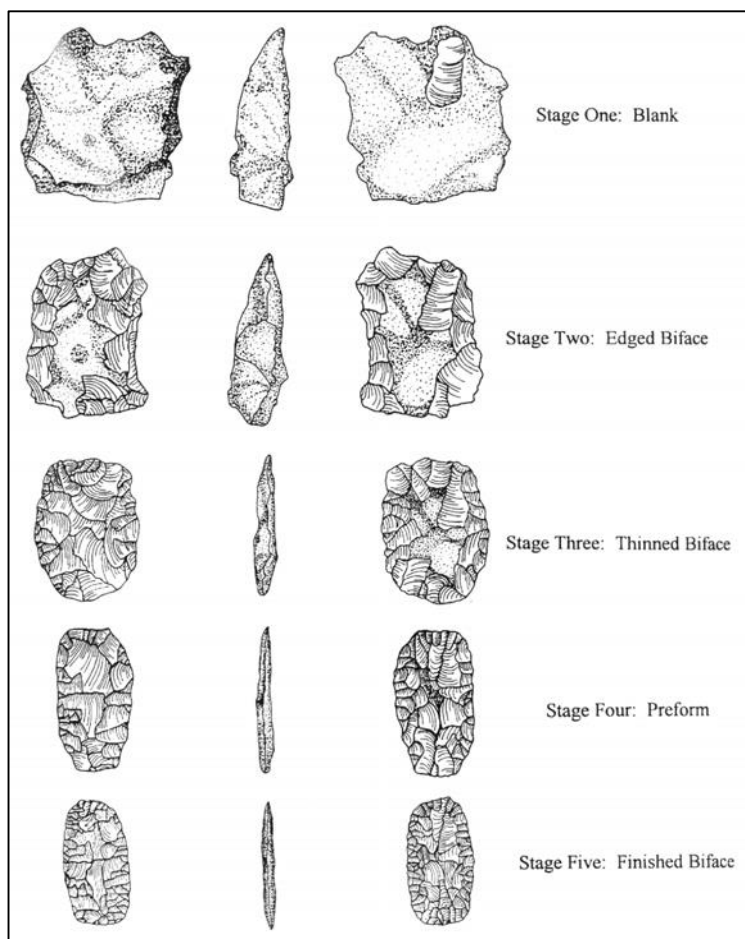


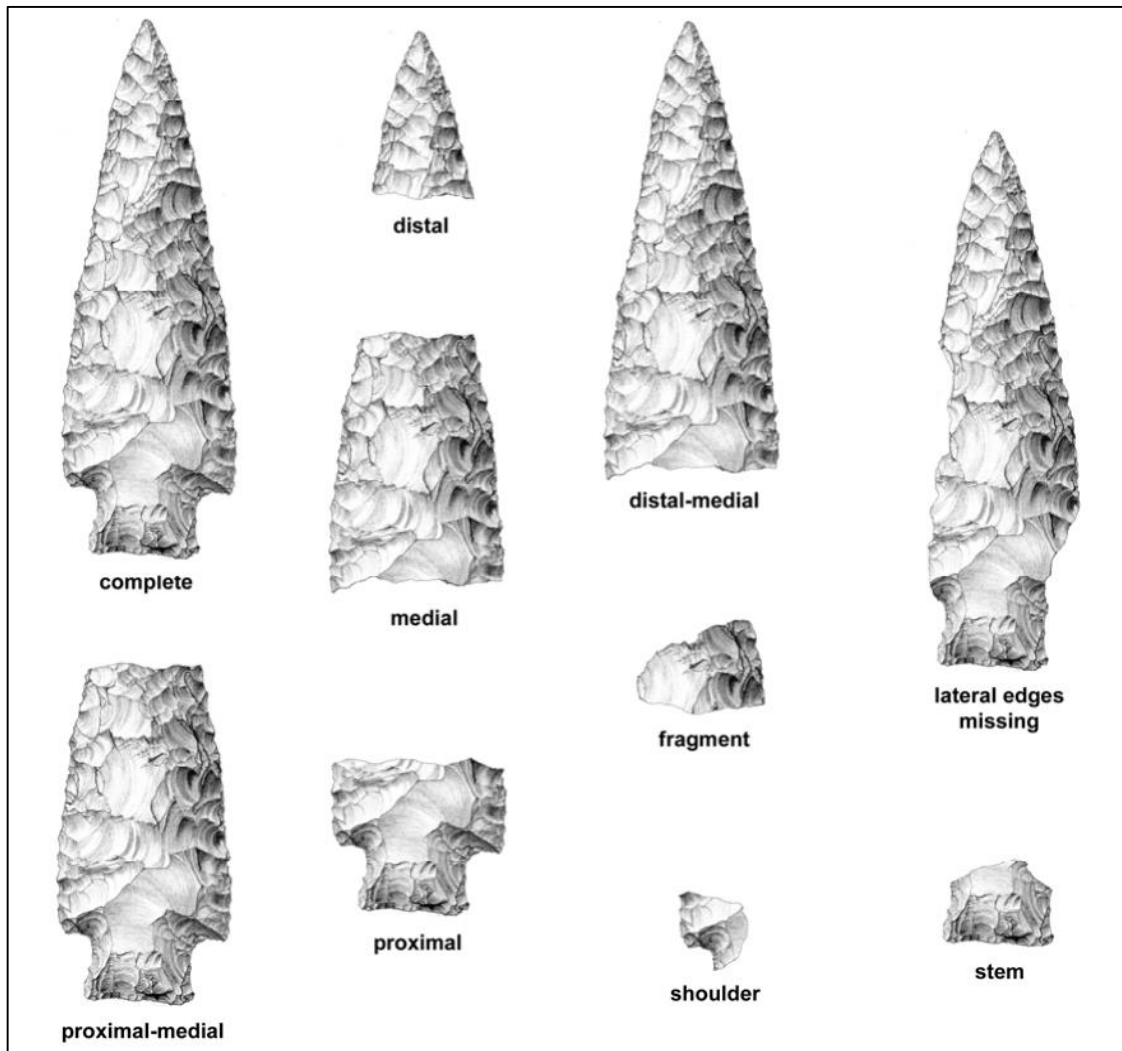
Figure G-7. Give stages of Chipped Stone Analytical Protocol.

material can no longer absorb the vibrations (Whittaker 1994: 213). Bending fractures can also occur quite commonly as the result of tool use. Use-derived bending fractures manifest as lateral truncations that often display a rolled or lipped edge along one side of the termination (Shafer 1985: 283). Recording the portion of the tool that was recovered is necessary for adding context to metric measurements.

When a rolled lip is observed, it often indicates that the tool was subjected to excessive torque during use. Snap fractures may also derive from material flaws, such as cavities or crystalline inclusions,

which cause disharmony in the radiation of percussion waves through the material, or simply produce areas of weak structural integrity (see discussion of material flaws below). Step and hinge fractures present analogous difficulties for tool production or recycling, and while morphologically distinct, they are formed through similar circumstances.

They are treated as a single category of failure in this protocol. A step fracture happens when the outward force is too great causing the flake to bend to the point of breaking. This is typically caused by hitting the core with a motion that is too fast



**Figure G-8. Chipped stone tools are more often discovered in a broken state.**



which pulls the flake way faster than the propagation through the core; thus causing the snap to occur (Crabtree 1972: 92; Whittaker 1994: 109).

Step fractures are similar to snap fractures with regard to the fracture mechanics of brittle solids in that they result in the truncation of material due to the unchanneled dispersion of percussive force. Hinge fractures occur when inadequate percussive force is applied to reduction efforts, preventing the flake from traveling the desired distance (Whittaker 1994:

109). However, rather than the flake being prematurely truncated as in step fractures, hinge fractures are characterized by the full termination of the flake. This termination occurs earlier than the intended point of egress, producing a rounded or blunt break and a disproportionate distribution of material mass that impedes further reduction efforts (Crabtree 1972:68).

Further reduction efforts often produce stacked step fractures or continued hinging, resulting in the inability to further reduce medial areas or to rejuvenate worn-out tool forms (Whittaker 1994: 109). Although they are morphologically dissimilar, the causes of hinge and step fractures, as well as the ensuing impediments for material reduction, are nearly equivalent (Whittaker 1994: 109). While step and hinge fractures often occur in the production of stone tools, they may also occur through tool use. Flakes may be inadvertently removed when tools come into contact with other materials as they are used in various tasks. Regardless of the trajectory stage, step and hinge fracture present a challenge to future reduction efforts, and may necessarily result in discard.

Failure and discard may also occur during reduction and rejuvenation efforts as the result of platform loss. The loss or collapse of a workable striking platform is often the consequence of improper reduction techniques or unanticipated fractures that

leave no viable surface on which to strike and remove a desirable flake. Platform loss can occur during efforts to remove excessive mass from the medial areas of cores, preforms, and recycled tools, and may result in the inability to remove a desired mass without compromising the dimensional requirements of the desired trajectory.

Material flaws generally manifest as mineral inclusions or cavities that differ compositionally from the package material. Irregular cleavage planes constitute another material obstacle that can impact the success of manufacturing efforts. When encountered, these flaws can produce anomalous fractures that complicate or preclude further reduction efforts. Common material flaws include macrocrystalline quartz, calcite, or fossil inclusions, as well as solution cavities and thermally-induced fractures. Production failures resulting from unanticipated thermally-induced fractures should be classified as “excessive heat” rather than “material flaw.”

Cotterell and Kamminga (1979) describe overshoot (*outrépassé*) failures as those that result from the application of excessive percussion force, and which cause the fracture path to dive into the objective piece and remove more than the intended mass. Such fractures often occur during the bifacial thinning of blanks and preforms, or in the removal of blades from prepared cores. While failures of this type are most frequently observed during primary production, they may also occur during rejuvenation efforts. Discard will generally be motivated by excessive medial thinning or unrecoverable compromise of the objects design.

Perverse fractures, as defined by Crabtree (1972b: 82), are a spiral or twisting break that initiates at the point of percussion and follows through the object, causing its segmentation. In terms of causation, perverse fractures are the result of a hair-line fracture that resulted from a previous blow. The spiral perverse fracture picks up the old fracture thus resulting in failure. These differ from

snap/bending fractures as they are not the result of excessive vibration, but result from a poor choice of striking angle and/or percussion force (as well as a bit of bad luck) that results in the plane of fracture traveling through rather than across the objective piece.

When more than one failure trait is expressed by an artifact, record the most significant cause for failure. For example, if a snap fracture resulted during production due to a fossil or crystalline quartz inclusion within the material, record material flaw as the cause of failure. In conjunction with other features of the assemblage, this information may potentially reveal preference patterns in raw material usage vis-à-vis specific tool classes, correlations between tool forms and discard patterning, and idiosyncratic differences in production skill.

### ***Use-related Discard***

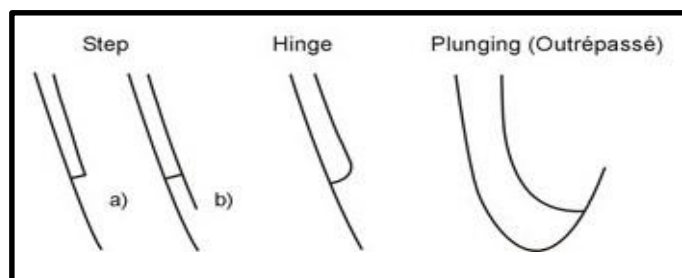
Stone tools may be lost in their use-context in myriad ways. Points attached to an errant arrow may be lost or broken; as well they may be carried off embedded in game that was not subsequently subdued. Tools can also be continuously curated and used to the point of material exhaustion. Objects may also be cached in the process of ritual activity, such as when placed in burials. The motives for use-related discard may only be definitively discerned in a limited number of cases. Points with distal spalling, perhaps combined with a stress fracture above the hafting element, may be understood to have suffered an impact fracture.

Tools recovered within a burial context may be identified as cached. Heavily recycled forms that cannot practically be further reduced through percussion or pressure flaking to yield an acute edge angle may be identified as exhausted tools. However, complete forms with light or no use-wear are commonly recovered at sites in contexts that do not explicitly indicate caching. When a discard motivation is ambiguous, “indeterminate” should be selected among the alternatives provided below.

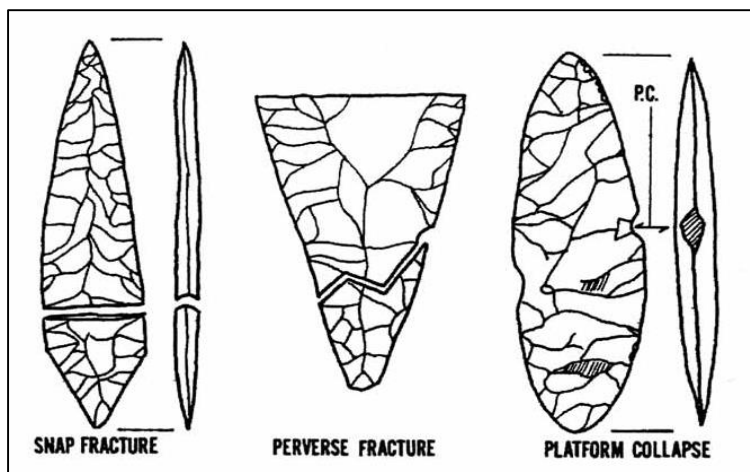
### ***Incidental Discard***

Incidental discard includes actions that removed objects from their systemic context by means other than manufacturing error, caching, or use (see Schiffer 1972), such as through dropping or misplacing them. However, this category of discard is a theoretical construct, the objective identification of which cannot be systematized. Thus, it is not included as an analytical option for assessing discard.

00. [Indeterminate]
01. [Snap / end shock]
02. [Impact / bending]
03. [Perverse]
04. [Hinge / step]
05. [Overshot (outrépassé)]
06. [Material flaw]
07. [Platform loss]
08. [Excessive heating]
09. [Exhausted]
10. [Cached]



**Figure G-9. These terminations are often observed on bifacial blanks and preforms that were discarded in the process of manufacture.**



**Figure G-10.** These terminations illustrate additional failures that may render the objective piece unusable or incapable of further reduction and recycling.

For the purposes of the protocols, step and hinge fractured are recorded as a single category of failure as the result in a very similar obstruction to the knapper.

**16. Alteration (choose dominant form)**

Material alteration addresses the transformation of structural and compositional properties that occurs as the result of natural and cultural processes. Natural processes include chemical and mechanical weathering, often resulting in patina or material decay. Thermal alteration is an example of material alteration through cultural processes.

An accurate assessment of thermal alteration is often inhibited by artifact size, patina formation, and unfamiliarity on the part of the researcher with some of the lithological variability expressed by select raw materials. Lithic raw materials typically undergo significant and detectable lithological changes with prolonged exposure to heat. Such changes are often desirable and may be deliberately generated by tool producers through controlled firing. Heat-treated materials may be more easily worked by the artisan as the process renders low-quality materials more knappable (albeit while making them more brittle and decreasing their durability).

The identification of heat-treated materials brings culture process and the details of economic activity to the fore. Nonetheless, it is frequently difficult to distinguish purposefully treated materials from those that were incidentally burned. Incidental firing occurred in antiquity through controlled vegetation burns, as well as the occasional burning of middens or other cultural deposits. Historic-age and modern incidental firing may have resulted from burning off surface vegetation when preparing land for cultivation of pasture.

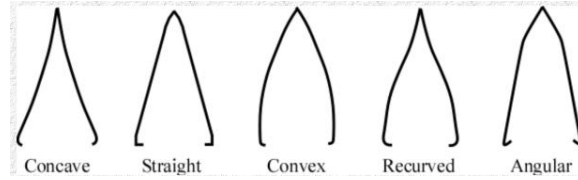
Lithic assemblages often exhibit other forms of material alteration that can obscure the study of raw material properties. The most common of these is the development of a weathering rind that is often identified as a white patina. The rind may be semi-translucent to opaque and is typically less than 3mm in thickness. The development of a yellow to reddish brown “stain” may also develop on lithic artifact surfaces in iron-rich soils. The chemical processes that lead to the development of black (often dark blue) patinas is not completely understood. They most often occur in inundated deposits. Carbonate deposits and pigment staining occur rarely, the former being most common in coastal areas and the latter more common in ritual contexts.

- 00. [Indeterminate]
- 01. [Thermal]
- 02. [White patina]
- 03. [Black patina]
- 04. [Oxide staining (yellowing)]
- 05. [Pigment staining]
- 06. [Carbonate build-up]
- 99. [Other]

### 17. Edge Morphology (D & L & R)

Please indicate the shape of the working edge of the tool. Measuring from a line strung between edge termini, an edge is characterized as very convex if the distance from the cord to the maximum outward projection of the edge is greater than or equal to 5mm. Similarly, an edge is considered convex if the distance from the cord to the maximum outward projection of the edge is between 4.9mm and 2mm. Edges are considered straight if the maximum inward or outward projection of the edge from the cord is no more than 1.9mm. An edge is considered concave if the distance from the cord to the maximum inward projection of the edge is between 4.9mm and 2mm. An edge is characterized as very concave if the distance from the cord to the maximum inward projection of the edge is greater than or equal to 5mm. An edge is considered recurved if the maximum outward projection of the edge from the cord is greater than or equal to 2mm, and the maximum inward projection of the edge from the cord is also greater than or equal to 2mm.

- 00. [Indeterminate]
- 01. [Straight]
- 02. [Concave]
- 03. [Convex]
- 04. [Recurved]
- 05. [Serrated]
- 06. [Very Convex]
- 07. [Very Concave]
- 99. [Not applicable]



**Figure G-11. Edge morphology has its greatest utility in characterizing projectile points, darts, and knives.**

### 18. Flake Scar Pattern

Flake scars are the impressions that remain on the face of a flaked stone artifact which are produced by the detachment of flakes during tool manufacture. The pattern of flake removal may offer important insights relating to the distribution of design templates and techniques of manufacture, as well as offer a means by which to observe variability in production design at different spatial scales.

- 00. [**Indeterminate**] a flaking pattern cannot be determined.
- 01. [**Collateral**] a flaking style that is characterized by parallel flakes emanating from opposing edges which meet in the center of the blade, forming a median ridge.
- 02. [**Horizontal transverse**] a flaking style that is characterized by horizontal, parallel flake scars emanating along one edge, traveling across the face of the blade, and terminating at the opposing edge.
- 03. [**Oblique transverse**] a flaking style that is characterized by long, diagonal, parallel flake scars emanating along one edge, traveling across the face of the blade, and terminating at the opposing edge.
- 04. [**Random**] flake removals do not reflect an aesthetic template in their distribution or alignment.
- 99. [**Not applicable**] (expedient flake tools are one form of tool that will not exhibit a flake scar pattern).

### 19. Edge Construction Type

Edge construction type references the location and form of preparatory edge construction on the objective piece. There are a variety of ways in which an edge may be constructed on a chipped stone object. The most basic choice is between bifacial and unifacial constructions. Such choices carry implications for accurately assigning tools to a subgroup, distinguishing between techniques used during production, assessing the foci of use, and determining the angle of the resulting edge. Variability may also occur among subtypes, potentially alluding to differences in raw material access, tool function, or nuances of social identity. For example, while the lateral margins of some Perdiz points are bifacially constructed, others exhibit unifacially beveled edges. The constructed working edge(s) of a tool may be characterized using the following descriptions:

- 00. [Indeterminate]
- 01. [Bifacial-distal]
- 02. [Bifacial-bilateral]
- 03. [Bifacial-unilateral]
- 04. [Bifacial-distal-bilateral]
- 05. [Bifacial-distal-unilateral]
- 06. [Bifacial-circumferential]
- 07. [Unifacial-distal]
- 08. [Unifacial-bilateral]
- 09. [Unifacial-unilateral]
- 10. [Unifacial-distal-bilateral]
- 11. [Unifacial-distal-unilateral]
- 12. [Unifacial-circumferential]
- 13. [Other]
- 99. [Not applicable]

### 20. Proximal Edge Grinding

- Not Observed
- Observed

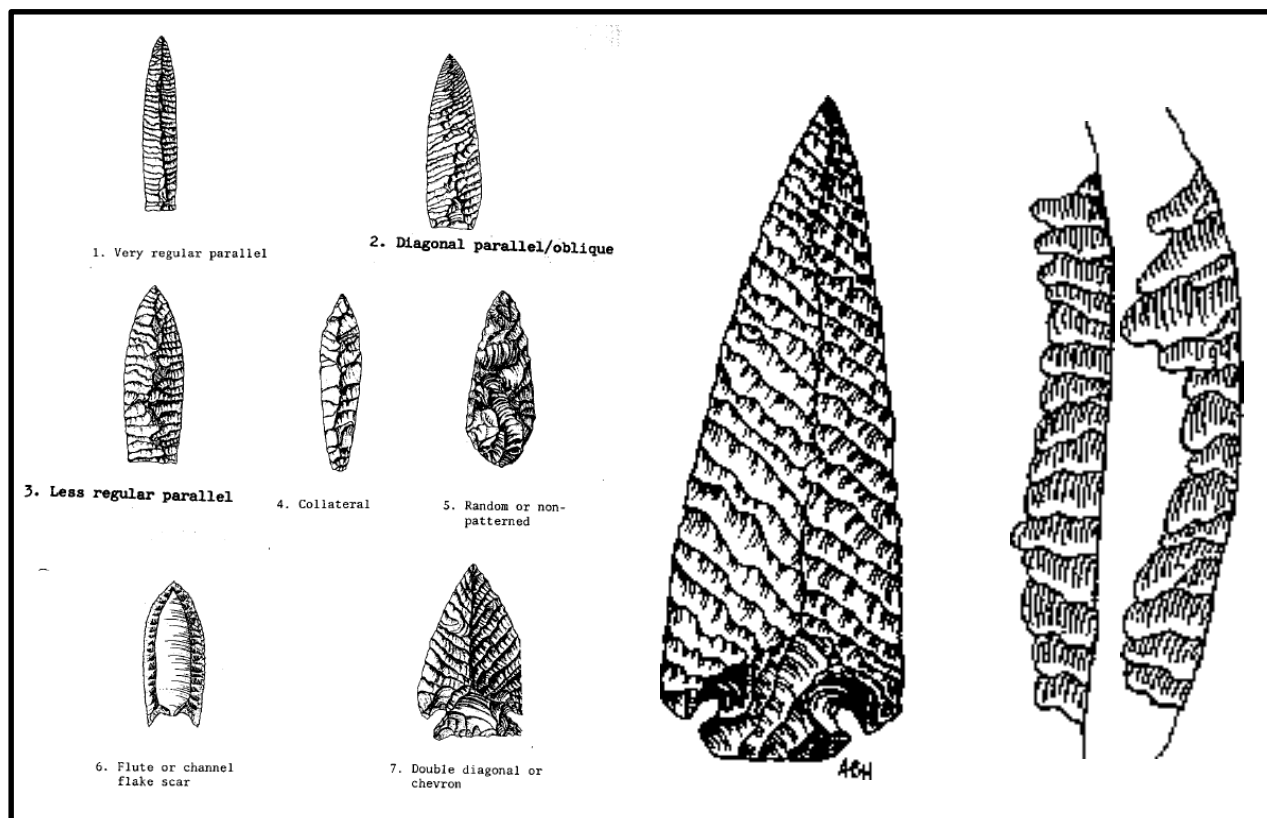


Figure G-12. Patterns of flake removal in edge construction, potentially related to flaking technique, tool function, aesthetic display, and social identity.

## **G.5 WEAR PATTERNING**

The following use-wear observations can be made macroscopically using an 18-20X jeweler's loop, and is considered low-power magnification. Low-power magnification is assumed to imply magnification between 18x-power and 100x-power. This portion of the protocol has not been designed for high-power magnification and Scanning Electron Microscopy. Use-wear characterization using low-power magnification has been shown to successfully identify the range of motion an object was used in, and, to a lesser degree, the hardness of the contact material. High-power magnification is generally needed to accurately identify contact material and detect finer details of object use. The low- power use-wear characterization advocated here will find its greatest utility in quantifying the presence or absence of use, identifying the area of use on a specific piece, and in identifying variability in use among specific artifact types and subtypes. The use-wear categories described below are not mutually exclusive – tools may exhibit more than one form of wear.

Edge modification is not always the product of material use. Other natural and cultural processes, such as trampling and archeological excavation, have been shown to produce edge modification similar to that developed through actual use (McBrearty, et al. 1998; Shea and Klenck 1993; Tringham, et al. 1974). Such processes obviously affect the recognition of some patterns of wear more than others, and may be particularly relevant for detecting true use- wear on simple detachment-based tools. Distinguishing use-derived flake terminations along the lateral margins of tools is perhaps the most equivocal functional assessment; although Odell and Odell-Vereecken (1980) state that the patternlessness of such incidental attrition is detectable and, thus, can be distinguished from actual use-wear with a high level of accuracy. Tools may exhibit a form of polish in deflationary zones derived from aeolian processes, and may exhibit

battered edges within fluvial deposits. Given the possibility that edge modification derived from trampling or other processes, “attrition” use-wear should only be record for artifacts that exhibit both a distinct, clustered pattern of edge alteration and worn or polished facets in the area of proposed use. While this undoubtedly underestimates the actual amount of use-wear exhibited throughout the assemblage, it substantially increases the accuracy with which positive determinations were made.

The degree of expedient tool use within an assemblage provides one means by which the level and importance of material conservation may be evaluated. Regions characterized by a scarcity of utilitarian lithic raw materials have been shown to exhibit higher levels of material recycling. Careful attention to and recording of use-wear may also provide important information related to spatial and temporal variability expressed within tool classes, types and subtypes.

### **21. Flaking Attrition**

Material mass is often removed from the working edge of a tool during the process of use. Much of this attrition is in the form of small flake removals that typically exhibit feathered or stepped terminations. Accurate recording of use-derived attrition requires an analyst to distinguishing these removals from trimming flakes that are detached along a tool's edge in the final preparation stage prior to use. Use-derived attrition can often be distinguished from preparatory trimming as it creates a more obtuse edge angle in the area of use than is expected based on observing edge characteristics elsewhere on prepared, but unused portions of the tool. Use-derived attrition may also remove areas of polish that have developed along tool margins, which may also produce sharper facets that contrast in the area of use with more polished and rounded facets.

Data is coded to record the presence and location of flaking attrition as its distribution on a tool

form is a significant indication of tool function. Observations shall be recorded as follows:

00. [Not present] Use if flaking attrition is not observed.
01. [Bifacial-distal] Use if the working edge of a tool is located along the distal margin and attrition is observed on each face (dorsal and ventral).
02. [Bifacial-bilateral] Use if both lateral margins exhibit use-derived attrition and the attrition has resulted in removals on both faces.
03. [Bifacial-unilateral] Use if only one lateral margin (left or right) exhibits use-derived attrition and the attrition has resulted in removals on both faces.
04. [Bifacial-distal-bilateral] Use if both lateral margins and the distal margin exhibit use-derived attrition and the attrition has resulted in removals on both faces. This option will be select if one of the lateral margins exhibits unifacial attrition.
05. [Bifacial-distal-unilateral] Use if only one lateral margin (left or right) and the distal margin exhibit use- derived attrition and the attrition has resulted in removals on both faces.
06. [Bifacial-circumferential] Use if the lateral margins along the entire circumference of the tool form exhibit use-derived attrition and the attrition has resulted in removals on both faces.
07. [Unifacial-distal] Use if the distal margin exhibits use-derived attrition and the attrition is observed on only one face.
08. [Unifacial-bilateral] Use if both lateral margins exhibit use-derived attrition and the attrition has resulted in removals on only one face.
09. [Unifacial-unilateral] Use if only one lateral margin (left or right) exhibits use-derived attrition and the attrition has resulted in removals on only one face.
10. [Unifacial-distal-bilateral] Use if both lateral margins and the distal margin exhibit use-derived attrition and the attrition has resulted in removals on only one face.
11. [Unifacial-distal-unilateral] Use if only one lateral margin (left or right) and the distal margin exhibit use- derived attrition and the attrition has resulted in removals on only one face.
12. [Unifacial-circumferential] Use if the lateral margins along the entire circumference of the tool form exhibit use-derived attrition and the attrition has resulted in removals on only one face.
13. [Unifacial-bilateral-oppositional] This form of attrition is most typically found on tools used as drills or awls. Use if both lateral margins exhibit use-derived attrition and the attrition has resulted in removals along the opposing margins of each face.
14. [Other] Use if none of the above apply and enter a description in the text box provided.

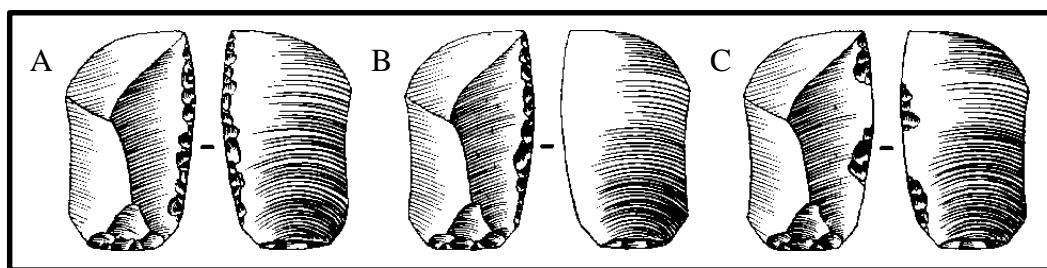


Figure G-13. Examples of lateral edge flaking attrition. (A) bifacial-unilateral; (B) unifacial-unilateral; (C) Platform abrasion and (likely) post-depositional removals.

## **22. Crushing**

Crushing and smoothing describe the form of wear attained through battering, grinding, or polishing. The tool is typically blunted through battering or abrasion against a hard contact material in the process of use. Crushed working surfaces may be a normally achieved trait with little effect of tool utility, such as with hammerstones. Alternatively, crushed surfaces may be an undesired consequence of use and material attrition that necessitates edge resharpening. Smoothing is typically the result of intensive abrasion and is commonly observed on tools used for grinding, polishing, or burnishing (uncommon among chipped stone tools). Once identified, the distribution of this wear should be recorded using one of the following descriptions:

00. [Not present] Use if attrition through crushing or smoothing is not observed.
01. [Distal]
02. [Distal-lateral]
03. [Unilateral]
04. [Bilateral]
05. [Facial Smoothing]
06. [Facet Smoothing]
07. [Circumferential]
08. [Primary Proximal]
09. [Secondary Proximal]

## **23. Polish**

The use-wear category “polish” describes lustrous areas on the tool, typically located at the distal or lateral margins, but occasionally noted on medial surfaces. Record polish as “shallow” when it is restricted to within 5mm of an edge. Define polish as “deep” when it extends beyond 5mm from the edge of its origin.

The origin of polish is not well understood despite having been the subject of generous scholarly attention (Odell 2001). Research into the nature of use-polish is generally focused either on the patterns of polish formed on stone tools as the result of a specific set of activities (cf. Aoyama

1999; Keeley 1977, 1980; Semenov 1964), or on the genesis and composition of polish itself (Fullagar 1991; Grace 1996; Odell 2001). In controlled studies where specific tool forms were utilized in a defined set of prescribed behaviors, researchers have had considerable success in correlating patterns of polish distribution and composition with the specific activities that generated its development. However, studies have also shown that a diverse set of activities may produce virtually identical patterns of use-polish (Lewenstein and Walker 1984). Researchers have also found that specific patterns of polish development do not correlate well with isolable tasks on multifunctional tools (Clark 1988).

It is perhaps best to consider that the form of the tool, the raw material used in its manufacture, and the patterns of wear (in any form) observed will provide a range of functional possibilities and limitations for how the tool was used in a particular cultural and techno-environmental setting.

Three processes other than primary contact during use may cause the development of a lustrous sheen, and they should not be recorded as use-derived polish. The first, hafting polish, develops through secondary, use-associated contact. Hafting polish is formed through the tools contact with a hafting element or fastening material. Hafting polish, when present, will typically manifest on both lateral and medial surfaces nearer the proximal end of a tool. Hafting can also be associated with worn, ground, or otherwise blunted lateral margins. Evidence for hafting should be nominally recorded separately from use-wear (see #26 below).

The second process that inhibits the detection of use-derived polish is thermal alteration. In extreme cases, lithic material will become vitrified through over-exposure to heat, producing a lustrous sheen that covers the surface of the artifact and resembles use-derived polish. Grinding, the third process, is a specialized manufacturing technique that results in the development of a luster across the ground



surface. The luster forms through the extensive abrasion required in the production process rather than from use.

The formation of polish is dependent on the nature of the tool construction material, nature of the contact material, and duration of use.

- 00. [Not present] Use if use-derived polish is not observed.
- 01. [Shallow distal <5mm]
- 02. [Deep distal >5mm]
- 03. [Shallow lateral <5mm]
- 04. [Deep lateral >5mm]
- 05. [Unifacial-medial]
- 06. [Bifacial-medial]
- 07. [Bipolar]
- 08. [Proximal]

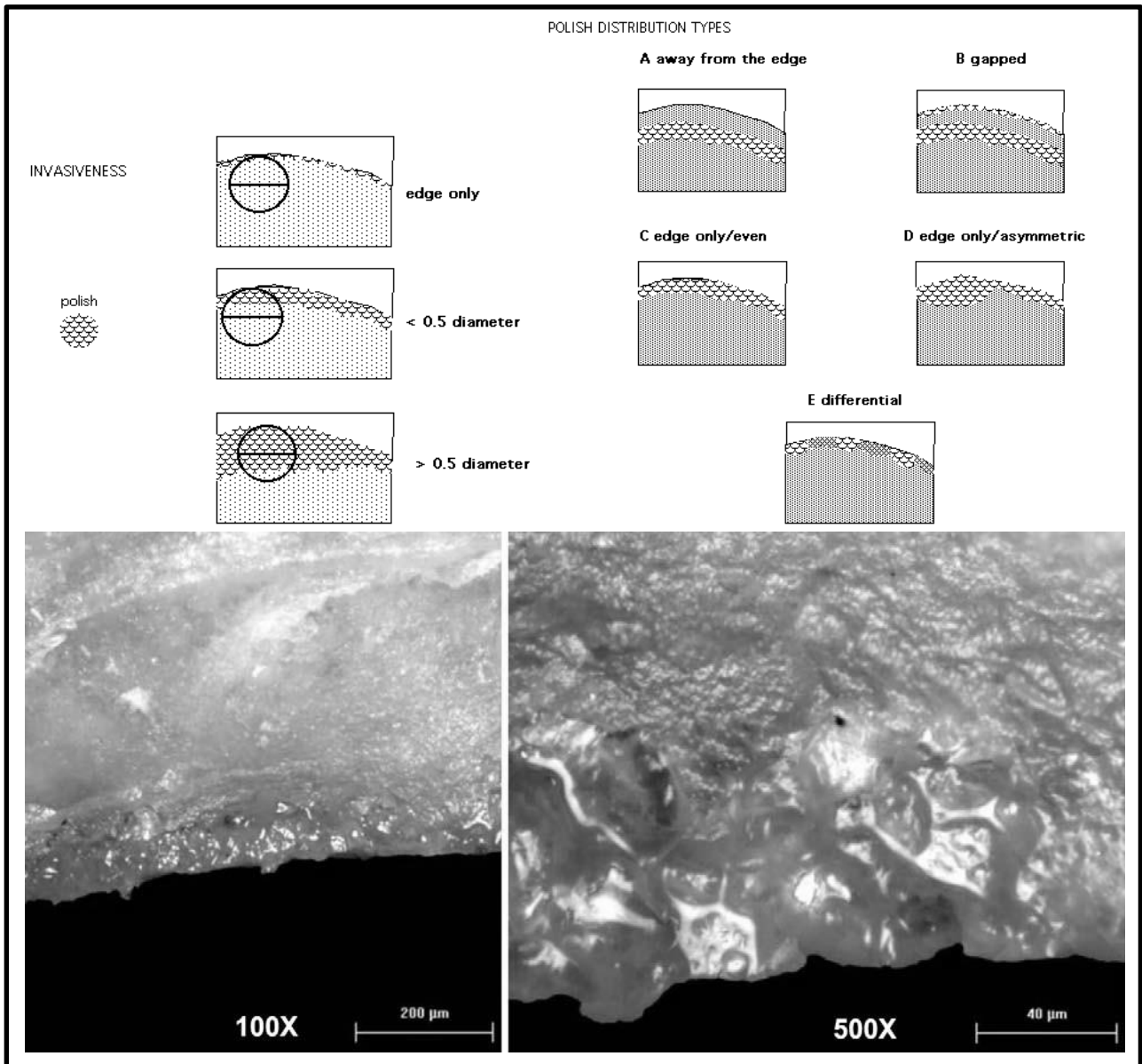


Figure G-14. Patterns of polish formation and distribution related to use-wear.

## 24. Etching / Pitting

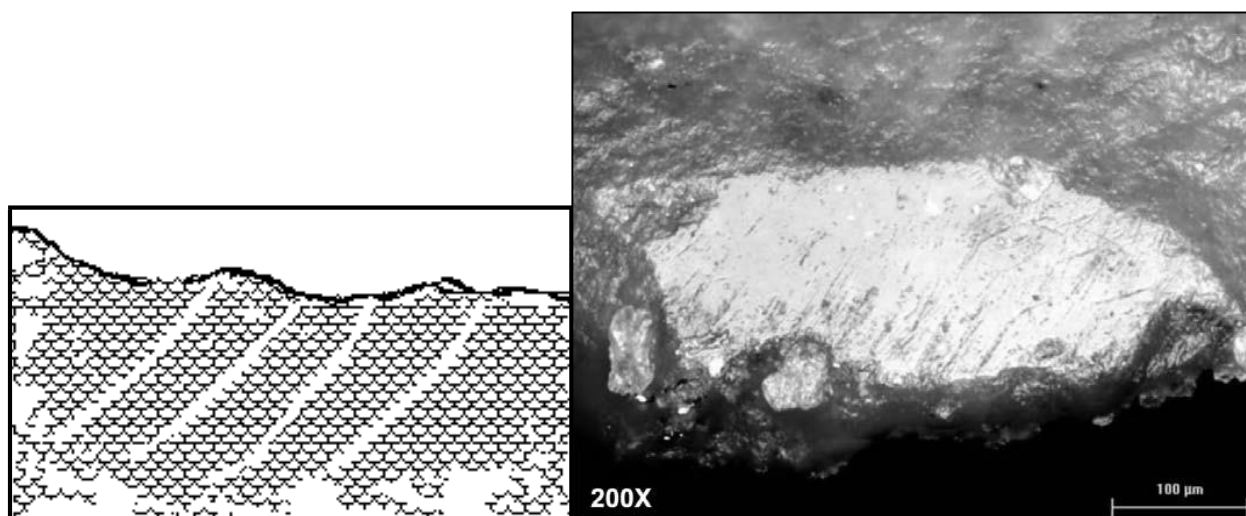
Etching and pitting refer to striations or small cavities produced through abrasive contact (Semenov 1964). As with polish, such markings may occasionally derive from production techniques, although this is generally only a concern for tool forms featuring ground or pecked and ground bits. Etching and pitting are better studied microscopically. The macroscopic techniques used in this study are useful for detecting moderate to deep scarring and abrasion that are characteristic of working soils with a significant sand content, but they may have less utility in detecting wear left from working in clayey soils. Striations (etching) may be located along either the distal or lateral margins of the tool. When located at the distal margin they most often run perpendicular to the edge. The extent to which they proceed from the distal margin across the face of a tool can provide some measure of how far the tool penetrated into a contact material. When located along the lateral margins striations more typically run parallel the edge. Striations may be created through quarrying, soil working, planning, polishing, grinding, or any extended lateral movement across a hard or abrasive surface.

- 00. [Not present] Use if attrition through etching or pitting is not observed.
- 01. [Shallow distal <5mm]
- 02. [Deep distal >5mm]
- 03. [Shallow lateral <5mm]
- 04. [Deep lateral >5mm]
- 05. [Unifacial-medial]
- 06. [Distal-medial]
- 07. [Circumferential]
- 08. [Medial-bifacial]
- 09. [Bipolar]

## 25. Hafting Evidence

Hafting may be identified through lateral edge dulling toward the proximal end of the tool form, polish along the proximal lateral margins and proximal facial facets, and the residual presence of a masticate such as asphaltum. Note the presence or absence of this evidence.

- Not Observed
- Observed



**Figure G-15.**Development of lateral scars (or striations) developed on the working edge of the tool derived from abrasive and repeated contact between the tool form and contact material.

## G.6 RAW MATERIAL

### 26. Lithology

The lithologic character of raw materials should be identified to the best, most accurate extent reasonable. The lithic analyst should specifically identify materials only to the extent that they are certain that the information provided is accurate. The most common raw materials have been coded for use. Materials not included in the list provided should be coded as “other” and specifically identified in the text field provided.

01. [Unidentified Silex]
02. [Microcrystalline Quartz]
03. [MacrocrySTALLine Quartz]
04. [Chalcedony]
05. [Jasper]
06. [Chert]
07. [Chert-Chalcedony Blend]
08. [Dolomite]
09. [Agatized Dolomite]
10. [Fossilized Wood]
11. [Limestone]
12. [Silicified Limestone]
13. [Quartzite]
14. [Novaculite]
15. [Rhyolite]
16. [Basalt]
17. [Serpentine / Greenstone]
18. [Steatite (soap stone)]
19. [Granite]
20. [Marble]
21. [Gneiss]
22. [Schist]
23. [Silt-stone]
24. [Obsidian]
25. [Manning Fused Glass]
26. [Ironized sandstone]
  
96. [Unidentified Sedimentary]
97. [Unidentified Igneous]
98. [Unidentified Metamorphic]
99. [Other]

### 27. Source Identification

The source areas provided below represent those commonly identified in available literature, but the list is by no means exhaustive (see Banks 1990; Turner and Hester 1999). The identification of lithic raw material source is intended to provide a means to address issues of resource mobilization. However, many issues exist in accurately identifying source areas. For example, Uvalde Gravels contain a good amount of Edwards Chert. The raw material source area should be 21 identified to the most accurate level possible without unsupportable speculation. It is expected that raw material source areas will not generally be identifiable.

In general, raw material sourcing is assessed using visual identification for chert, chalcedony, and quartzite artifacts as chemical characterization studies have not been reliable in determining source areas. Successful identification of specific resource outcrops is often impossible, but some confidence regarding the general can be gained by matching artifacts (formal tools and debitage) to geological samples taken from individual resource outcrops (ex. Edwards, Alibates, Maravillas, Ogallala). Relevant criteria to consider in matching archeological materials to geological samples include lithology, material hardness, relative grain size, color, the presence or absence of banding and other irregularities, and the presence and composition of microfossils and other inclusions (cf. Morrow 1994). In most instances, determining the area of procurement depends on artifact mass as only large pieces will retain enough compositional character to distinguish between geographically discrete resource areas.

00. Unidentifiable
01. Alibates (Llano Estacado)
02. Antlers Formation
03. Burro Mesa (Trans-Pecos)
04. Bexar County chert
05. Callahan Divide
06. Caballos Mountain

- 07. Central Mineral Region (Llano Uplift)
- 08. Georgetown Cherts
- 09. Edwards Chert
- 10. Manning Fused Glass
- 11. Markely Conglomerate
- 12. Pisgah Ridge
- 13. Rio Grande Gravels
- 14. Tecovas Formation (cherts and jaspers)
- 15. Yegua Gravels (quartzite and petrified wood)
- 16. Uvalde Gravels
- 17. Catahoula
- 97. Unidentified local
- 98. Unidentified regional
- 99. Unidentified exotic
- 100. Other

**G.7 PROJECTILE POINT DATA**

**28. Point Class**

- 00. Not Applicable
- 01. Corner Notched
- 02. Side Notched
- 03. Stemmed
- 04. Triangular
- 05. Lanceolate

**Table G-1. Example of Tool Observations and Measurements**

	Corner Notched	Side Notched	Stemmed	Triangular	Lanceolate	Measurement	Description
	X	X	X	X	X	point length	same as question #8 above
	X	X	X	X	X	point width	same as question #9 above
	X	X	X	X	X	point ratio	Tool width divided by tool length
30a.	X	X	X	X	X	blade length (L)	
29b.	X	X	X	X	X	blade length (R)	
30c.	X	X	X	X	X	base/stem length or	
30d.	X	X	X			base/stem width	
30e.	X	X	X		X	neck thickness	
30f.	X	X	X		X	neck width	May be the same as #30d in stemmed forms, and the same as #9 in Lanceolate forms.
30g.	X	X				notch depth (L)	
30h.	X	X				notch depth (R)	
	X	X				notch ratio	Average notch depth divided by width of point
	X	X	X	X	X	base to blade ratio	29e divided by 30a
	X	X	X			base to blade ratio	29f divided by 30b
	X	X	X			base/stem ratio	0 (indeterminate), 1 (short; $\leq 0.7$ ), 2 (proportionate; $>0.7$ & $<1.3$ ), 3 (long; $\geq 1.3$ )
30i.	X	X	X			base form	0 (indeterminate), 1 (convex), 2 (straight), 3 (concave),
30j.			X			stem form	0 (indeterminate), 1 (contracting), 2 (parallel), 3 (expanding), 4 (asymmetrical)
30k.				X	X	distal base form	0 (indeterminate), 1 (convex; $\geq 1$ mm), 2 (straight; $<1$ mm & $>-1$ mm), 3 (concave; $<-1$ mm)
30l.			X		X	lateral base/stem form	0 (indeterminate), 1 (contracting), 2 (parallel), 3 (expanding – exhibits tangs), 4 (asymmetrical)
30m.	X	X	X	X	X	blade curvature (L)	0 (indeterminate), 1 (very convex; $\geq 5$ mm), 2 (convex; $<5$ mm & $\geq 2$ mm), 3 (straight; $<2$ mm & $>2$ mm), 4 (concave; $\leq -2$ mm), 5 (recurved; $<-2$ mm & $>2$ mm)
30n.	X	X	X	X	X	blade curvature (R)	0 (indeterminate), 1 (very convex; $\geq 5$ mm), 2 (convex; $<5$ mm & $\geq 2$ mm), 3 (straight; $<2$ mm & $>2$ mm), 4 (concave; $\leq -2$ mm), 5 (recurved; $<-2$ mm & $>2$ mm)

	Corner Notched	Side notched	Stemmed	Triangular	Lanceolate	Measurement	Description
30o.	X	X	X			shoulder angle (L)	
30p.	X	X	X			shoulder angle (R)	
30q.			X			shoulder junction	0 (indeterminate), 1 (curved), 2 (angular), 3 (straight)
30r.				X		base angle (L)	
30s.				X		base angle (R)	
	X	X	X	X	X	index of symmetry	

Note: Shaded Rows Have Automatically Populated Data and Should Not Be Manually Entered.

## G.8 TXDOT PROTOCOL FOR DEBITAGE ANALYSIS

### *Research Methods: Debitage*

There is a great deal of information that may be gained from the study ofdebitage in archeological assemblages, and researchers have debated the utility of various classes of information, as well as their situational applicability, accuracy, and level of efficiency (Ahler 1989; Andrefsky 1998; Baumler and Downum 1987; Johnson 1989; Magne 1989; Sullivan and Rossen 1985). The analytical process described here provides a useful synthesis of attribute analysis and mass analysis that captures the maximum amount of critical basic data for large collections within a workable time frame while allowing a wide range of research questions to be addressed.

Within this protocol, no linear measurements are recorded for individual artifacts (i.e. flake length, width, thickness, and curvature; platform angle, width, and thickness). Such measurements rarely lend themselves to addressing important or innovative research questions. They also require a large amount of time to collect when analyzing sizable collections and this time investment is invariably unwarranted when assessed against the amount of useful information returned.

### *Metric Attributes (Number and Weight)*

In the interest of analytical efficiency, there is also no good reason to weigh individual flakes. Counts and weights will be assessed for artifact groupings (analytical assemblages) that are created through the analytical process.

### *Minimum Number of Nodules (MNN)*

An assessment of MNN is designed to record the minimum number of individual packages of raw material (nodules) that contributed to a specific analytical assemblage. This may be relevant for determining the number/volume of tools produced, the number of individuals participating in the production activity, raw material preferences, or the degree of deflation, comingling, or disturbance reflected in the assemblage being analyzed. This assessment should be based on observations of raw material type and material properties, and may be augmented through the use of ultraviolet fluorescence. Analysts should consider the effects of differential patination and thermal alteration on observable raw material features when assessing MNN. Analysts should favor lumping over splitting in determining MNN (additional nodules should only be recorded when flakes within an analytical assemblage cannot have been derived from the same source package).

***Form (Completeness – flake vs. frag vs. shatter)***

Sullivan and Rozen (1985:759) have advocated using the analytical categories “complete flake”, “broken flake”, “flake fragment”, and “debris” for the study of flake assemblages, and have illustrated the tendency for each to be represented in different proportions at various stages of manufacture (see also Baumler and Downum 1987). There are many variables that undermine the utility of this approach. Landscapes used for pasture or cultivation, particularly in near-surface deposits, are highly susceptible to trampling and to disturbance by agricultural machinery. Either agent will distort the ratio of complete to broken flakes in such contexts. The movement of artifacts in vertic soils or within contexts characterized by erosion and re-deposition, root disturbances, and ancient cultural disturbances such as area maintenance (to name only a few) are equally likely to affect this ratio. Interpreting manufacturing stage through the percentage of whole vs. broken flakes requires preservation of integrity, in both individual specimens and the original composition of the assemblage, with little post-depositional alteration. Due to the rarity of such an occurrence, the interpretive worth of the categories advocated by Sullivan and Rozen find their greatest utility when used with experimental assemblages.

This protocol does not require that only those flakes within an assemblage that retain a striking platform (whole and proximal flakes) be included for data collection and analysis. While this would reduce spurious data produced through post-depositional processes, distal flake fragments may be excluded from analyses by most statistical packages.

***Size-grade Analysis***

Sort all debitage by size-grade using nested sieves with 1-inch, ¾-inch, ½-inch, and ¼-inch apertures. Size-grade analysis offers an alternative to taking standard metric measurements of maximum flake length, width, thickness (cf.

Andrefsky 1998: 96-100) that substantially increases the efficiency with which large samples may be studied (Ahler 1989). When combined with supplementary data, such as the percentage of dorsal cortex present and platform type, size-grade analysis provides researchers with valuable information regarding production trajectory, the method and organization of raw material procurement, technology of production, production efficiency, and the level of material curation (Ahler 1989; Baumler and Downum 1987; Behm 1983; Bradbury and Franklin 2000).

01. [1-inch sieve, 26.2 mm]
02. [¾-inch sieve, 19.0 mm]
03. [½-inch sieve, 12.5 mm]
04. [¼-inch sieve, 6.4 mm]

***Cortex Percent***

Perhaps the most common use of cortex observations in debitage analysis is for assessing the stage of manufacture represented by the flake assemblage. Researchers commonly use one of two models of assigning meaning to the percentage of cortex present. The first uses the relative amount of cortex present on each flake to place the individual piece within a linear reduction model, under the assumption that only flakes produced during the initial phases of tool manufacture will exhibit a high percentage of dorsal cortex. Andrefsky (1998:111) refers to this as the “triple cortex” approach, and it can be recognized by the identification of *primary*, *secondary*, and *tertiary* (or *interior*) flakes. As researchers Sullivan and Rozen (1985:756-757) have pointed out, however, there is little standardization among those employing the triple cortex approach, such that the flakes designated as *primary* may be required to have as much as 100 percent dorsal cortex or be permitted to exhibit as little as 50 percent.

Similarly, the percentage of dorsal cortex required to identify a *secondary* flake ranges between 100 and 0 percent depending on the researcher, while the percentage of dorsal cortex required for the

identification of a *tertiary* flake ranges from between 0 and 25 percent (Sullivan and Rossen 1985:757). As a significant number of *tertiary* flakes -which are often regarded as evidence of final stage manufacture- are produced in the initial phases of core reduction, the traditional classification of debitage into primary, secondary, and tertiary flakes has very little analytical worth.

Ahler (1989:90) has pointed out that the presence of cortex in a lithic waste assemblage, as well as the utility of information gleaned from its study, will vary according to the nature of the raw material, how it was quarried, the reduction technology employed, and the stage of manufacture represented by the assemblage. Also, the presence of cortex at any reduction stage is dependent on the initial presence of cortex prior to reduction (Andrefsky 1998:113-114). The nature of raw material outcrops, the method of quarrying employed, and the technology of production affects the viability of using cortex percent as an indicator of production stage. Even under the best of circumstances, cortex percent may only provide data relevant to broadly distinguish early reduction stages from later stages (Mauldin and Amick 1989:71). Debitage is able to more accurately inform reduction stage and artifact class when classified according to size, percentage of cortex represented, and platform type. The following size categories should be used for classifying debitage.

Cortex Percentages

- 00. [0%]
- 01. [1-25%]
- 02. [26-50%]
- 03. [51-75%]
- 04. [76-100%]

***Platform Type***

The striking platform of a flake is the point of contact where the percussor initiated the flake detachment. The morphology of the platform can yield valuable information pertaining to the stage of manufacture represented by the flake, which in turn

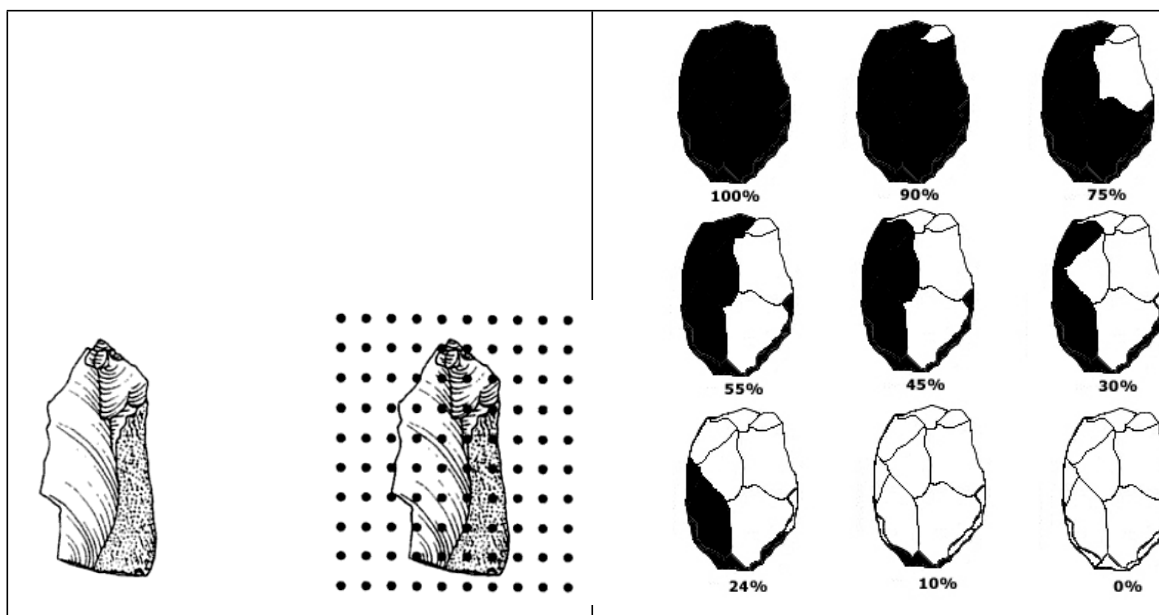
reflects the presence, character, and organization of activity areas. Platform morphology can also inform production technology (Andrefsky 1998).

Platform types should be recorded as indeterminate, cortical, flat, complex, abraded, faceted, multifaceted, and rejuvenated (cf. Andrefsky 1998:93-96). Cortical platforms are those that retain some amount of unmodified cortex, and are generally attributable of early production stages. Cortical flakes also generally, but do not necessarily, exhibit dorsal cortex beyond the platform. Flat striking platforms exhibit a smooth, un-faceted striking surface.

Flakes detached from unidirectional cores generally exhibit flat platforms (Andrefsky 1998:94), although flakes with flat striking platforms may also be produced in the early stages of bifacial core reduction. Faceted striking platforms exhibit one or more facets, reflecting the removal of previous flakes from the same general area.

Although researchers have had some success in determining manufacturing stage using facet counts (Mauldin and Amick 1989; McAnany 1988), time constraints and unresolved ambiguity in directly correlating facet count with manufacturing stage in an uncontrolled archeological sample undermine the desirability of including this finer resolution. A simple distinction between single faceted platforms and multifaceted platforms is advocated in this protocol. Flakes that exhibit bifacial mass removal, often referred to as bifacial thinning flakes, are categorized as having complex platforms. Abraded platforms are those that exhibit attrition caused by purposeful edge preparation procedures. Such platforms are generally rounded or ground in appearance, and often exhibit multiple tiny step fractures. Marginal abrasion is a common practice for preparing a striking platform, and serves as a method of altering the direction of percussor force, which produces a more predictable flake removal





**Figure G-16.** The graphic above illustrates both a quantifiable and a qualitative means by which to measure or estimate the amount of remnant dorsal cortex on a lithic flake.

(Andrefsky 1998:96; Whittaker 1994).

Abraded platforms are produced in all phases of tool manufacture, but are more common in later stages of production. Finally, rejuvenated platforms reflect tool resharpening and often display remnant use-wear along a focal margin. Assemblages dominated by rejuvenated platforms indicate tool maintenance rather than tool production.

Indeterminate identifications generally result from poorly represented (fractured) or wholly absent platforms, or from poor resolution caused by heavy patina. To be clear, it is not desirable to record platform width and thickness or the number of facets present on the dorsal surface of flakes. These attributes are not efficiently recorded through mass analysis procedures, and the information they provide may be ascertained through other means, such as multivariate analysis incorporating the percentage of dorsal cortex present with flake size and platform type.

- 00. [Indeterminate]
- 01. [Cortical] flakes with cortex observed on striking platforms are produced in the initial stage of package reduction.
- 02. [Flat] a single facet, caused by characterizes the striking platform.
- 03. [Faceted] two facets are observed on the platform. Assemblages dominated by flakes with double faceted platforms are generally produced in early stage blank production.
- 04. [Multifaceted] multiple facets are observed on the platform. Assemblages dominated by flakes with multifaceted platforms are generally produced through work on later stage preforms.
- 05. [Abraded] the platform exhibits ground margins
- 06. [Complex] complex platforms are bifacial.
- 07. [Rejuvenated] rejuvenated platforms are indicative of recycling and will typically exhibit worn edges and remnant polish.
- 08. Missing


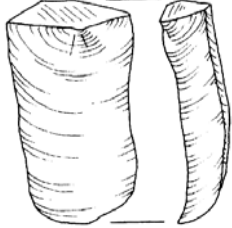
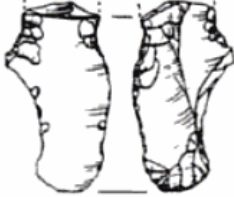
**Thermal Alteration**

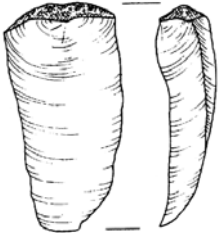

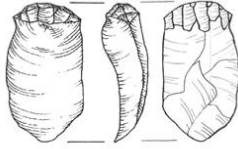
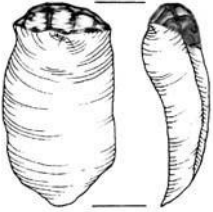
Thermal alteration is used here to describe the process of purposefully subjecting lithic materials to a heat source as a means to affect raw material properties. Lithic raw materials typically undergo significant and detectable lithological changes with prolonged exposure to heat. Such changes are often desirable and may be deliberately generated by tool producers through controlled firing. Heat-treated materials may be more easily worked by the artisan, thus rendering low-quality materials more useful (albeit while making them more brittle and decreasing their durability).

An accurate assessment of thermal alteration is often inhibited by artifact size, patina formation, the production of comparable attributes through incidental fire exposure, and unfamiliarity on the part of the researcher with the lithological variability expressed by select raw materials in

their natural state. The identification of heat-treated materials can bring culture process and the details of economic activity to the fore. For example, the presence of thermal alteration in combination with an assessment of platform type and cortex representation can indicate the trajectory stage at which the objective piece was heat-treated.

Nonetheless, it is frequently difficult to distinguish purposefully treated materials from those that were incidentally burned. Given the inherent difficulty with distinguishing between materials that were purposefully heat-treated (cultural process) as opposed to fire-affected (incidental alteration resulting from both natural and cultural processes), debitage should be recorded as thermally altered, not altered, or indeterminate with regard to alteration conservatively and through incorporation of ancillary data.

Platform Type	Platform Description	Illustration
missing	Flakes are defined as having missing striking platforms if they are flake fragments or shatter that are missing the proximal segment of the flake that includes the point of fracture initiation.	
cortical	Flakes with cortex observed on striking platforms are generally produced in the initial stage of package reduction.	
flat	A single facet, caused by a single previous flake removal, characterizes this type of striking platform. Flat (single faceted) platforms are common in early stages of decortification, and are common to blade manufacture when combined with notably abraded edges.	

Platform Type	Platform Description	Illustration
dihedral-faceted	A surface having or formed by two intersecting faces. Assemblages dominated by flakes with double faceted platforms are generally produced in early stage blank production.	
multifaceted	Multiple facets are observed on the platform but only along one face of the object. Light abrasion may or not be present. Assemblages dominated by flakes with multifaceted platforms are generally associated with later stages of biface reduction but can also be present in early stage biface reduction.	
abraded	Abraded platform exhibit grinding that may obliterate facet ridges and/or exhibit platform edge smoothing/rounding visible to the naked eye or under low-power magnification. Heavily abraded platforms are often “dull” or smooth to the touch. Abraded platforms serve to strengthen a platform edge allowing for the application of greater force loads thus increasing successful flake propagation and decreasing platform failure by crushing or collapse.	
complex	Complex platforms exhibit pressure or light percussion scars on the proximal-dorsal flake surface originating from the platform edge. These scars are typically associated with precision platform preparation (i.e., isolation and orientation) of late stage bifaces where manufacturing failure rates increase proportional to width to thickness ratios.	
rejuvenated	Rejuvenated platforms are indicative of recycling and will typically exhibit worn edges and remnant polish.	
indeterminate	In some instances, the platform type will not be determinable even when the striking area is present.	

**Figure G-17.10-20x magnification (hand lens or loop) is recommended for viewing platforms on debitage in the ¼ -½ inch size grades.**

Identifying alteration on pieces with insufficient mass is unreliable, and so all small-sized debitage that is not minimally captured by a ½-inch mesh sieve should be recorded as indeterminate. If a piece has been determined to be altered its context and association should be considered (e.g. if other artifact classes for the same context similarly burned the piece is more likely to have been incidentally fire affected).

00. [Indeterminate]

01. [Thermal alteration observed]

02. [Thermal alteration not observed]

### ***Analytical Process***

By combining the above attributes into criteria lists and then recording the number and aggregate weight of flakes that fit a given set of criteria, this system allows for numerous unique attribute combinations for all debitage within a given provenience. This system works efficiently for large volumes of material and produces an easily queried database.

First, flakes from a given provenience should be sorted by raw material or individual package where it is obvious that the assemblage represents the reduction of separate material packages and such packages are distinctly identifiable. Uniquely identifiable raw material groupings will represent distinct analytical assemblages within each

provenience. Next, for each separate package group, sort whole and proximal flakes by size within a given spatial context. Following this, inspect flakes within the 1-inch and ¾-inch sieve size groups for evidence of use-wear (use-derived edge modification is unlikely to be reliably reflected on smaller flakes and they should not be evaluated for possible use).

Remove utilized flakes for analysis under the chipped stone tool protocol. Next, within each size group, sort flakes according to whether or not they are thermally altered (this step will not be performed for the two smallest size groups). Sort flakes within each alteration group (or size group if not separated by alteration) according to the amount of dorsal cortex that is present. From each of the cortex groups, sort flakes by platform type. Finally, count and record the total number of flakes in each of these final groupings and collectively weigh them in grams (round to the nearest gram) and record the MNN for the grouping.

Data derived from formal tool and debitage analyses are complementary. Each data set provides a more informed perspective on the other. Individually, however, each data set may make a distinct contribution with respect to illuminating a particular set of cultural processes and behaviors.

Material	Period	Size Grade	Cortex	Platform	Thermal Alteration	Edge Modification
00 – indeterminate	01 – Early Paleo	01 – 1”	00 – 0%	00 - indeterminate	00 - no	00 - absent
01 – local	02 – Late Paleo	02 - ¾”	01 - 1-25%	01 - cortical	01 - yes	01 - present
02 – regional	03 – general Paleo	03 - ½”	02 – 26-50%	02 - flat	02 - indeterminate	
03 – exotic	04 – Early Archaic	04 - ¼”	03 – 51-75%	03 - faceted.		
	05 – Middle Archaic		04 – 76-100%	04 - abraded		
	06 – Late Archaic			05 - complex		
	07 – Transitional Archaic / Early Ceramic			06 - rejuvenated		
completeness	08 – general Archaic			Metrics <input type="checkbox"/> record number within each final grouping <input type="checkbox"/> record aggregate weight of final group		
01 – complete	09 – Late Prehistoric					
02 – broken	10 – Historic (general)					
03 – fragment	11 – Historic (Spanish)					
04 - debris	12 – Historic (French)		General Period		Regions (from T.B.H.)	
	13 – Historic (Mexican)		01 – Paleo Indian		1. Plateaus and Canyonlands	
	14 – Historic (Texas Republic)		02 – Archaic		2. South Texas Plains (Rio Grande)	
	15 – Historic (Confederate)		03 – Late Prehistoric		3. Mountains and Basins	
	16 – Historic (1870-present)		04 – Historic		4. Prairies and Marshlands	
	17 – General Historic				5. Rolling Plains	
					6. Timbers and Prairies	
minimum number of individual nodules					7. Pineywoods	
					8. High Plains	

TAXONOMY

- 1. Technology:
- 2. Group:
- 3. Subgroup:
- 4. Class:
- 5. Subclass:
- 6. Type:
- 7. Identity:

- 03. Perverse
- 04. Hinge / Step
- 05. Overshot (outrepasse)
- 06. Material flaw
- 07. Platform loss
- 08. Excessive heating
- 09. Exhausted

METRIC INFO/MEASUREMENTS

- 8. Max length (mm):
- 9. Max width (mm):
- 10. Max thickness (mm):
- 11. Weight (g):
- 12. Edge angle (working edge averaged to nearest 5°):

- 16. Alteration
  - 00. None observed
  - 01. Thermal
  - 02. White patina
  - 03. Black patina
  - 04. Oxide staining (yellowing)
  - 05. Pigment staining
  - 06. Carbonate build-up

ATTRIBUTES

- 13. Stage
  - 00. Indeterminate
  - 01. Initial reduction
  - 02. Early stage forming
  - 03. Late stage perform
  - 04. Finished product
  - 05. Recycled

- 17. Edge Morphology [17a=L; 17b=R]
  - 00. Indeterminate
  - 01. Concave
  - 02. Convex
  - 03. Recurved
  - 04. Serrated

- 14. Portion
  - 00. Indeterminate
  - 01. Complete
  - 02. Distal
  - 03. Distal-medial
  - 04. Medial
  - 05. Proximal-medial
  - 06. Proximal
  - 07. Lateral edges missing
  - 08. Fragment
  - 09. Barb / shoulder
  - 10. Ear / tang
  - 11. Stem

- 18. Flake Scar Pattern
  - 00. Indeterminate
  - 01. Collateral
  - 02. Horizontal transverse
  - 03. Oblique transverse
  - 04. Random
  - 99. Not Applicable

- 15. Failure
  - 00. Indeterminate
  - 01. Snap / end shock
  - 02. Impact / bending

19. Edge Construction Type

- 00. Indeterminate
- 01. Bifacial – distal
- 02. Bifacial – bilateral
- 03. Bifacial – unilateral
- 04. Bifacial – distal – bilateral
- 05. Bifacial – distal – unilateral
- 06. Bifacial – circumferential
- 07. Unifacial – distal
- 08. Unif – bilat – conforming
- 09. Unif – bilateral – opposing
- 10. Unifacial – unilateral
- 11. Unif – distal – bilateral-conform
- 12. Unif – distal – bilateral-opp
- 13. Unifacial – distal – unilateral
- 14. Unifacial – circumferential
- 15. Other
- 99. Not applicable

20. Proximal edge grinding

- Not observed
- Observed

WEAR PATTERNING (macroscopic)

21. Flaking

- 00. Not present
- 01. Bifacial – distal
- 02. Bifacial – bilateral
- 03. Bifacial – unilateral
- 04. Bifacial – distal – bilateral
- 05. Bifacial – distal – unilateral
- 06. Bifacial – circumferential
- 07. Unifacial – distal
- 08. Unifacial – bilateral - conform
- 09. Unifacial – bilateral - opposing
- 10. Unifacial – unilateral
- 11. Unif – distal – bilateral-conform
- 12. Unif – distal – bilateral-opposing
- 13. Unifacial – distal – bilateral
- 14. Unifacial – distal – unilateral
- 15. Unifacial – circumferential
- 16. Other

22. Crushing

- 00. Not Present
- 01. Distal
- 02. Distal – lateral
- 03. Unilateral
- 04. Bilateral
- 05. Facial smoothing
- 06. Facet smoothing
- 07. Circumferential
- 08. Primary proximal
- 09. Secondary proximal

23. Polish

- 00. Not present
- 01. Shallow distal (<5mm)
- 02. Deep distal (>5mm)
- 03. Shallow lateral (<5mm)
- 04. Deep lateral (>5mm)
- 05. Unifacial medial
- 06. Bifacial medial
- 07. Bipolar
- 08. Proximal

24. Etching / Pitting

- 00. Not present
- 01. Shallow distal (<5mm)
- 02. Deep distal (>5mm)
- 03. Shallow lateral (<5mm)
- 04. Deep lateral (>5mm)
- 05. Unifacial medial
- 06. Distal medial
- 07. Circumferential
- 08. Medial bifacial
- 09. Bipolar

25. Hafting evidence

- Not observed
- Observed
- Not Applicable

**RAW MATERIAL**

**26. Lithology**

- 01. Unidentified Silex
- 02. Microcrystalline Quartz
- 03. Macrocrystalline Quartz
- 04. Chalcedony
- 05. Jasper
- 06. Chert
- 07. Chert-Chalcedony Blend
- 08. Dolomite
- 09. Agatized dolomite
- 10. Fossilized Wood
- 11. Limestone
- 12. Silicified Limestone
- 13. Ortho-Quartzite
- 14. Meta-Quartzite
- 15. Novaculite
- 16. Rhyolite
- 17. Basalt
- 18. Serpentine / Greenstone
- 19. Steatite (soap stone)
- 20. Granite
- 21. Marble
- 22. Gneiss
- 23. Schist
- 24. Silt-stone
- 25. Obsidian
- 26. Manning Fused Glass
- 27. Ironized sandstone
- 96. Unidentified Sedimentary
- 97. Unidentified Igneous
- 98. Unidentified Metamorphic
- 99. Other

**27. Major Sources**

- 00. Unidentifiable
- 01. Alibates (Llano Estacado)
- 02. Antlers Formation
- 03. Burro Mesa (Trans-Pecos)
- 04. Bexar County chert
- 05. Callahan Divide
- 06. Caballos Mountain
- 07. Central Mineral Region (Llano Uplift)
- 08. Georgetown Cherts
- 09. Edwards Chert
- 10. Manning Fused Glass
- 11. Markely Conglomerate
- 12. Pisgah Ridge
- 13. Rio Grande Gravels
- 14. Tecovas Formation (cherts and jaspers)
- 15. Yegua Gravels (quartzite and petrified wood)
- 16. Uvalde Gravels
- 17. Catahoula
- 97. Unidentified local
- 98. Unidentified exotic
- 99. Other

**PROJECTILE POINT DATA**

**28. Point Class**

- 00. Not Applicable
- 01. Corner-Notched
- 02. Side-Notched
- 03. Stemmed
- 04. Triangular
- 05. Lanceolate



### **Questions for Middle-Level and High-Level Theory Using Debitage Data**

\* Many of these questions can be best or only answered with respect to complementary data from other material classes.

#### **QUESTIONS**

1. What is being produced? (biface, blades, expedient flakes, points, etc... may be identified by class or type).
2. What techniques were used in its production? (bifacial reduction, prismatic core, bipolar reduction, channel flaking, etc...).
3. What part of the production process is represented by the available assemblage? (stage in trajectory).
4. What function was the objective piece meant to serve? (this deduction is generally only possible when waste can be related to finished products with observable use-wear, or production failures of known function).
5. How many were being made? (flake-to-tool ratios are inherently spurious without diagnostic flakes and researchers should be cautious when addressing this issue; raw material type differences may be valuable in establishing a minimum number objects produced).
6. Who was making it? (age, gender, and social status are typically central to this issue, and the question may be best addressed –if it is indeed possible to do so– with respect to the context and composition of deposit, and its association with identified activity areas).
7. How many people were involved in creating the assemblage and what was their relationship? (this assumes that the waste actually has the meaning that we assign to it and that variation in flaking is not the result of an ancillary feature in the

manufacturing process such as raw material type and quality).

8. Is this where the constituent components of the assemblage originally entered the archeological record? (the integrity of deposit should be considered with respect to natural and cultural transformation processes, including disturbances and patterns of refuse disposal).
9. Was the product for immediate use? (consider degree of material curation, production stage, environmental setting, and degree of expediency in tool design).
10. Was the material easy to come by? (consider the local availability of the raw material, as well as the degree of material curation and conservation observed in the relative percentage of use-wear observed on flakes, and the degree to which tools are recycled).
11. Was the raw material easy to use? (this assessment of raw material quality may be addressed through error rates and thermal alteration, but also in consideration of the amount of material mass that remains when expended tools are discarded).

#### **G.9 REFERENCES CITED**

- Ahler, S. A.  
1988 Mass Analysis of Flaking Debris: Studying the Forest Rather than the Tree. In *Alternative Approaches to Lithic Analysis*, edited by D. O. Henry and G. H. Odell, pp. 85-118. Archaeological Papers, Vol. 1. American Anthropological Association, Washington, DC.
- 1989 Experimental Knapping with KRF and Midcontinent Cherts: Overview and Applications. In *Experiments in Lithic Technology*, edited by D. S. Amick and R. P. Mauldin, pp. 199-234. Vol. 528. British

- Archaeological Reports International Series 528. Oxford.
- Andrefsky, W.  
1998 *Lithics: Macroscopic Approaches to Analysis*. Cambridge Manuals in Archeology. Cambridge University Press, Cambridge, England.
- Aoyama, K.  
1999 Ancient Maya State, Urbanism, Exchange, and Craft Specialization: Chipped Stone Evidence from the Copán Valley and the La Entrada Region, Honduras. University of Pittsburgh Memoirs in Latin American Archaeology, No. 12. University of Pittsburgh Dept. of Anthropology, Pittsburgh, PA.
- Banks, L. D.  
1990 From Mountain Peaks to Alligator Stomachs: A Review of Lithic Sources in the Trans-Mississippi South, the Southern Plains, and Adjacent Southwest. Oklahoma Anthropological Society, Memoir No. 4.
- Baumler, M. F. and C. E. Downum  
1987 Between Micro and Macro: A Study in the Interpretation of Small-sized Lithic Debitage. In *Experiments in Lithic Technology*, edited by D. S. Amick and R. P. Mauldin, pp. 101-116. British Archaeological Reports International Series 528. Oxford.
- Behm, J. A.  
1983 Flake Concentrations: Distinguishing Between Flintworking Areas and Secondary Deposits. *Lithic Technology* 12(1):9-16.
- Black, S., K. Miller, G. Goode, L. Ellis, S. Decker, and E. Prewitt  
1997 Appendix C: Artifact Descriptions. In *Hot Rock Cooking on the Greater Edwards Plateau: Four Burned Rock Midden Sites in West Central Texas, Volume 2*, edited by S. Black, L. Ellis, D. Creel, and G. Goode, pp. 443-570. Studies in Archeology 22, Texas Archeological Research Laboratory, The University of Texas at Austin. Report 2, TxDOT ENV Archeological Studies Program.
- S. L. Black, L. W. Ellis, D. G. Creel, and G. T. Goode  
1997 *Hot Rock Cooking on the Greater Edwards Plateau: Four Burned Rock Midden Sites in West Central Texas*. 2 vols. Studies in Archeology 22, Texas Archeological Research Laboratory, The University of Texas at Austin, and Archeology Studies Program, Report 2, Environmental Affairs Division, Texas Department of Transportation, Austin.
- Bradbury, A. P. and J. D. Franklin  
2000 Raw Material Variability, Package Size, and Mass Analysis. *Lithic Technology* 25(1):42-58.
- Clark, J. E.  
1988 The Lithic Artifacts of La Libertad, Chiapas, Mexico: An Economic Perspective. Papers of the New World Archaeological Foundation, 52. Brigham Young University, Provo, UT.
- Collins, M. B.  
1975 Lithic Technology as a Means of Processual Inference. In *Lithic Technology: Making and Using Stone Tools*, edited by E. H. Swanson, pp. 15-34. Mouton Publishers, The Hague, The Netherlands.

- Cotterell, B., and J. Kamminga  
1979 The Mechanics of Flaking. In *Lithic Usewear Analysis*, edited by B. Hayden, pp. 97-112. Academic Press, New York.
- Crabtree, D. E.  
1966 A Stoneworker's Approach to Analyzing and Replicating the Lindenmeire Folsome. *Tebiwa* 9(1):3-39.
- 1972a The Cone Fracture Principle and the Manufacture of Lithic Materials. *Tebiwa* 15(2):29-42.
- 1972b An Introduction to Flintworking. *Occasional Papers of the Idaho State University Museum*, Pocatello, ID. Fullagar, R. L. K.
- 1991 The Role of Silica in Polish Formation. *Journal of Archaeological Science* 18(1):1-24.
- Goode, G.  
2002 The Anthon Site: A Prehistoric Encampment in Southern Uvalde County, Texas. Report 8, TxDOT ENV Archeological Studies Program.
- Grace, R.  
1996 Use-wear Analysis: The State of the Art. *Archaeometry* 38(2):209-229.
- Johnson, J. K.  
1989 The Utility of Production Trajectory Modeling as a Framework for Regional Analysis. In *Alternative Approaches to Lithic Analysis*, edited by D. O. Henry and G. H. Odell, pp. 119-138. Archaeological Papers, Vol. 1. American Anthropological Association, Washington, DC.
- Keeley, L. H.  
1977 An Experimental Study of Microwear Traces on Selected British Paleolithic Implements. Unpublished Ph.D. dissertation, School of Archaeology, Oxford University.
- 1980 Experimental Determination of Stone Tool Uses: A Microwear Analysis. Prehistoric Archeology and Ecology. University of Chicago Press, Chicago.
- Lewenstein, S. M. and J. Walker  
1984 Obsidian Chip / Manioc Grating Hypothesis. *Journal of New World Archaeology* 6(2):25-38.
- Magne, M. P. R.  
1989 Lithic Reduction Stages and Assemblage Formation Processes. In *Experiments in Lithic Technology*, edited by D. S. Amick and R. P. Mauldin, pp. 15-32. British Archaeological Reports International Series 528. Oxford.
- Mauldin, R. P. and D. S. Amick  
1989 Investigating Patterning in Debitage from Experimental Bifacial Core Reduction. In *Experiments in Lithic Technology*, edited by D. S. Amick and R. P. Mauldin, pp. 67-88. British Archaeological Reports International Series 528. Oxford.
- McAnany, P. A.  
1988 The Effects of Lithic Procurement Strategies on Tool Curation and Recycling. *Lithic Technology* 17(1):3-11.
- McBrearty, S., L. Bishop, T. Plummer, R. Dewar and N. Conard  
1998 Tools Underfoot: Human Trampling as an Agent of Lithic Artifact Edge Modification. *American Antiquity* 63(1):108-129.
- Morrow, T.  
1994 A Key to the Identification of Chipped-Stone Raw Materials Found on

- Archaeological Sites in Iowa. *Journal of the Iowa Archeological Society* 41: 108-129.
- Woods and M. G. Pavesic, pp. 277-315. University of New Mexico Press, Albuquerque.
- Odell, G. H.  
2001 Stone Tool Research at the End of the Millenium: Classification, Function, and Behavior. *Journal of Archaeological Research* 9(1):45-100.
- Shea, J. J., and Klenck, J. D.  
1993 An Experimental Investigation of the Effects of Trampling on the Results of Lithic Microwear Analysis. *Journal of Archaeological Science* 20(2):175-194.
- Odell, G. H. and F. Odell-Vereecken  
1980 Verifying the Reliability of Lithic Use-Wear Assessments by 'Blind Tests': The Low-Power Approach. *Journal of Field Archaeology* 7(1):87-120.
- Sollberger, J. B.  
1977 Fracture Theory, Applied to Flaking Forces and Lithic Analysis. Paper presented at the Conference for Use-Wear, Simon Fraser University, Burnaby, British Columbia, Canada.
- Patterson, P.  
1977 A Lithic Reduction Sequence: A Test Case in the North Fork Reservoir Area, Williamson County, Texas. *Bulletin of the Texas Archeological Society* 48: 44-54.
- Sullivan, A. P. and K. C. Rozen  
1985 Debitage Analysis and Archaeological Interpretation. *American Antiquity* 50(4):755-779.
- Schiffer, M.  
1972 Archaeological Context and Systemic Context. *American Antiquity* 37: 156-165.
- Tringham, R., G. Cooper, G. H. Odell, B. Voytek and A. Witman  
1974 Experimentation in the Formation of Edge Damage: A New Approach to Lithic Analysis. *Journal of Field Archaeology* 1(1/2):171-196.
- Semenov, S.  
1964 *Prehistoric Technology* trans. M. Thompson. Cory, Adams, and MacKay, London.
- Tsirk, A.  
1979 Regarding Fracture Initiations. In *Lithic Use-wear Analysis*, edited by B. Hayden, pp. 83-96. Academic Press, New York.
- Shafer, H. J.  
1983 The Lithic Artifacts of the Pulltrouser Area: Settlements and Fields. In *Pulltrouser Swamp: Ancient Maya Habitat, Agriculture, and Settlement in Northern Belize*, edited by P. D. Harrison and B. L. Turner, pp. 212-245. University of Texas Press, Austin.
- Turner, E and T. Hester  
1999 A Field Guide to Stone Artifacts of the Texas Indians. Gulf Publishing, New York.
- Whittaker, J. C.  
1994 *Flintknapping: Making and Understanding Stone Tools*. 1st ed., University of Texas Press, Austin.

*This page intentionally left blank.*

## **APPENDIX H**

# **PLANT REMAINS FROM 41LM49, 41LM50, 41LM51, LAMPASAS COUNTY, TEXAS**

Prepared for:



TRC Environmental Corporation  
505 East Huntland Drive, Suite 250  
Austin, Texas 78752

Prepared by:

J. Phil Dering, Ph.D.  
Shumla Archeobotanical Services  
P.O. Box 944  
110 Alpine St.  
Comstock, TX 78837

January 2005

*This page intentionally left blank.*

## **PLANT REMAINS FROM 41LM49, 41LM50, 41LM51, LAMPASAS COUNTY, TEXAS**

J. Phil Dering, Ph.D.

The purpose of this analysis is to provide an assessment of the botanical data in samples recovered from test excavations at 41LM49, 41LM50, and 41LM51. A total of 17 macrobotanical samples were examined.

### **H.1 METHODS**

The analysis followed standard archeobotanical laboratory procedures. The 17 macrobotanical samples were recovered *in situ* or picked from excavation screens. All of the plant material submitted for identification was carbonized wood. Identification was accomplished by using the snap technique, examining the fragments at 8 to 45 magnifications with a hand lens or a binocular dissecting microscope, and comparing the material to samples in the archeobotanical herbarium.

Counts and weights from each are presented in tabular format. These data reflect the potential for the three sites to yield useful botanical data, and provide preliminary information on local environmental conditions in the immediate area of the sites.

### **H.2 RESULTS AND CONCLUSIONS**

Table H-1 lists the identifications, counts, and weight of plant material recovered from each sample. All of the identified material was wood charcoal; no seeds, fruits, edible root, or nut fragments were noted in the samples.

Recovery of charred plant material was modest. The 17 samples contained a total of 120 fragments weighing 4.2 grams. Eight taxa or wood types were identified in the samples -- juniper, woody legume type, sycamore, hickory wood type, oak, buckeye, Mexican peach, and rose family wood type. Oak wood occurred in eight of the 17 samples, more than any other wood type, while buckeye and juniper were recovered in relatively large quantities in fewer samples.

The taxa consist of canopy and understory species that grow in the immediate area today. Buckeye and Mexican peach are small understory trees that are abundant along creek terraces. Juniper is more common on the valley slopes. Oak, and trees in the hickory family, which include walnut and hickory, are common in creek and river valleys. Although no hickory, walnut, or acorn fragments were identified, the presence of three forest mast-producing wood types suggests that there is a potential that nut fragments may be recovered in future investigations.

Of the three sites, samples from 41LM49 and 41LM51 contained the most carbonized plant material. Very little charcoal of one species, oak, was noted in samples from 41LM50, and three of the seven samples from that site did not contain identifiable carbonized plant material.

In contrast, 41LM49 contained three wood types, and 41LM51 contained five wood types, more than the other two sites combined. Based on the material identified in the samples, 41LM49 and 41LM51 may have the best potential to yield botanical data from future excavations.



**Table H-1. Identified Plant Material.**

Site	Cat #	Taxon	Common	Part	Count	Wt (g)
41LM49	3-007	<i>Prunus</i> sp.	Mexican Peach	Wood	7	0.1
41LM49	6-007	Fabaceae	Woody Legume	Wood	4	0.1
41LM49	6-007	<i>Quercus</i> sp.	Oak	Wood	9	0.5
41LM49	7-007	<i>Quercus</i> sp.	Oak	Wood	4	0.1
41LM49	8-007-1	<i>Quercus</i> sp.	Oak	Wood	2	<.1
41LM50	33-007-1	No Identifiable Carbonized Plant Remains				
41LM50	66-007-1	No Identifiable Carbonized Plant Remains				
41LM50	66-007-2	<i>Quercus</i> sp.	Oak	Wood	11	0.1
41LM50	67-007	<i>Quercus</i> sp.	Oak	Wood	2	<.1
41LM50	7-007	Indeterminate hardwood	NA	Wood	8	<.1
41LM50	71-007-1	<i>Quercus</i> sp.	Oak	Wood	3	<.1
41LM50	71-007-2	No Identifiable Carbonized Plant Remains				
41LM51	14-007	<i>Quercus</i> sp.	Oak	Wood	13	0.3
41LM51	13-007	<i>Quercus</i> sp.	Oak	Wood	3	0.1
41LM51	175-007	<i>Quercus</i> sp.	Oak	Wood	12	0.1
41LM51	176-007	No Identifiable Carbonized Plant Remains				
41LM51	2-007-1	<i>Juniperus</i> sp.	Juniper	Wood	25	0.3
41LM51	2-007-1	<i>Prunus</i> sp.	Mexican Peach	Wood	3	0.3
41LM51	2-007-2	<i>Aesculus</i> sp.	Buckeye	Wood	13	1.1
41LM51	2-007-2	<i>Juniperus</i> sp.	Juniper	Wood	2	0.2
41LM51	4-007	Juglandaceae	Hickory family	Wood	6	0.3
41LM51	45-007	Rosaceae sp.	Crabapple/peach	Wood	3	0.1
41LM51	94-007	<i>Platanus occidentalis</i>	Sycamore	Wood	11	0.5
41LM51	94-007	<i>Quercus</i> sp.	Oak	Wood	7	0.5

# **APPENDIX I**

## **LITHIC DEBITAGE ANALYSES**

Prepared for:



TRC Environmental Corporation  
505 East Huntland Drive, Suite 250  
Austin, Texas 78752

Prepared by:

Trisha Gonzales  
Paul Matchen  
Shannon Gray  
Robert A. Ricklis  
TRC Environmental Corporation

June 2014

*This page intentionally left blank.*

## **LITHIC DEBITAGE ANALYSES FOR 41LM50 AND 41LM51, AND LITHIC ANALYSIS FOR EXPERIMENTAL BIFACE STUDY**

Trisha Gonzales, Paul Matchen, Shannon Gray, and Robert A. Ricklis

### **I.1 SITES 41LM50 AND 41LM51**

The data in the Table I-1 and Table I-2 represent basic summaries of all lithic debitage analyzed as per TxDOT protocol (2010) for 41LM50 and 41LM51, respectively. Data is summarized by Lot number. Lot numbers are unique provenience numbers assigned to collections to reference each unit and each level within that unit. See lithic discussion in the report text. Full lithic debitage analysis data is also provided on the CD included with this report.

### **I.2 EXPERIMENTAL LITHIC ANALYSIS**

Data in Table I-3 represents the basic summary of the analysis performed by Ricklis (see Chapter 6.0 for Experimental Analyses) upon the lithic debitage produced by Ringstaff during manufacture of bifaces created for this experimental study. Data is summarized by Experimental Biface number.

A specialized protocol was developed by TxDOT and TRC in order to best address the parameters of the research design (see Chapter 5.0 for Research Design). The experimental debitage analysis database is provided on the CD included with this report. Also included on the CD are additional datasets utilized during the experimental study that the reader may find of interest.

**Table I-1. Summary of Lithic Debitage for 41LM50.**

Technology	Lot #	Qty
Debris	1	10
	2	30
	3	10
	4	22
	5	12
	6	13
	7	12
	8	10
	9	16
	10	18
	11	5
	12	6
	13	12
	14	11
	15	9
	16	12
	17	25
	18	12
	19	12
	20	6
	21	10
	22	6
	23	16
	24	13
	26	1
	27	14
	28	15
	29	14
	30	21
	31	15
	32	11
	33	17
	34	6
	35	28
	36	12
41	4	
42	4	
46	24	
47	61	
48	21	
52	28	
53	11	
54	4	
60	125	
61	38	
62	27	
71	23	
<b>Grand Total</b>	<b>832</b>	

**Table I-2. Summary of Lithic Debitage for 41LM51.**

Technology	Lot #	Qty
Debris	3	6
	4	1
	6	1
	7	4
	13	4
	14	2
	16	3
	17	5
	18	8
	53	74
	54	77
	88	82
	89	92
	103	16
	104	16
	<b>Grand Total</b>	<b>391</b>

**Table I-3. Summary of Lithic Analysis for Experimental Biface Study.**

Experimental Biface #	Size Grade	Cortex	Platform	Qty	Weight (g)
3 (Harahey)	01	00	01	2	>500
		01	01	3	
		02	01	3	
		03	01	1	
		04	01	5	
		00	00	1	27.4
		00	02	4	167.8
		00	03	1	21.8
		01	00	1	36.1
		01	01	2	81.5
		01	02	2	15.4
		02	02	1	51.3
		04	00	1	39.8
		04	08	11	182.5
	02	00	00	1	2.1
		00	01	1	6.6
		00	02	2	15.8
		00	08	6	38.2
	03	00	00	2	2.3
		00	02	4	7.6
		01	02	3	3.2
		01	02	1	2.9
		01	08	16	29.7
	04	00	02	5	1.6
		00	03	2	1.5
		00	00	22	5.6
		00	08	66	
	01	00	02	11	54.7
		00	03	1	13.5
		00	04	4	47.0
		00	04	1	34.4
		00	08	2	27.1
	02	00	00	4	3.2
		00	02	1	3.4
		00	03	1	3.4
		00	04	6	15.8
		00	08	18	27.2
	03	00	00	11	28.1
		00	01	1	0.6
		00	02	5	10.0

Experimental Biface #	Size Grade	Cortex	Platform	Qty	Weight (g)
3 (Harahey) – continued		00	04	5	8.0
		00	08	18	37.4
	04	00	00	50	19.0
		00	01	1	2.5
		00	02	14	7.6
		00	08	90	36.5
	01	00	00	1	12.3
		00	04	2	26.5
		00	06	6	49.0
		00	08	2	17.5
	02	00	00	2	10.3
		00	02	1	9.3
		00	06	3	21.2
		00	08	2	10.3
	03	00	00	11	16.2
		00	02	2	3.6
		00	03	1	0.8
		00	04	1	1.1
		00	06	3	5.6
		00	08	12	11.4
	04	00	00	48	14.9
		00	02	7	2.2
		00	03	4	2.1
		00	04	23	8.1
		00	06	1	0.3
		00	08	61	16.5
14 (Gahagan)	01	00	00	1	37.3
		00	01	1	37.3
	02	00	08	5	44.5
		02	08	1	8.9
	03	00	08	5	12.5
		01	08	1	3.3
		04	08	1	3.0
	04	00	02	1	0.2
		00	08	11	7.4
		01	08	4	5.6
		03	08	1	1.5
		04	08	1	0.6
	01	00	01	5	62.1
		01	00	1	4.7
		03	00	1	50.1
	04	00	1	12.5	

*Archeological Testing of TxDOT Right-of-Way Along FM 580W Over Lynch Creek  
Lampasas County, TX - Texas Department of Transportation*

<b>Experimental Biface #</b>	<b>Size Grade</b>	<b>Cortex</b>	<b>Platform</b>	<b>Qty</b>	<b>Weight (g)</b>
14 (Gahagan) – continued		04	08	2	12.9
	02	00	00	1	2.6
		00	01	2	6.4
		00	02	1	2.2
		00	08	2	8.3
		02	00	2	7.0
		04	08	1	1.3
	03	00	00	2	2.3
		00	01	10	20.4
		00	02	2	6.8
		00	08	5	7.1
		02	00	2	7.0
		04	02	2	5.3
		04	04	1	1.4
		04	08	6	6.8
	04	00	00	4	1.3
		00	01	8	2.8
		00	02	2	0.8
		00	08	39	14.9
		01	01	1	0.2
		01	08	11	3.7
		02	08	2	1.9
		03	08	2	0.5
		04	08	10	3.4
	01	00	00	2	29.8
		00	03	1	11.3
		00	08	2	38.9
		01	08	2	32.6
	02	00	00	8	22.9
		00	01	2	7.9
		00	03	2	5.6
		00	04	1	4.1
		00	08	6	21.2
	03	00	00	2	2.0
		00	01	5	3.0
		00	02	2	2.5
		00	03	3	5.7
		00	08	7	6.3
		01	00	1	0.2
		01	04	1	3.6
		04	08	1	1.1
	04	00	00	36	14.9



Experimental Biface #	Size Grade	Cortex	Platform	Qty	Weight (g)
14 (Gahagan) – continued		00	01	20	6.9
		00	03	3	1.4
		00	04	5	2.4
		00	08	70	18.0
		02	08	2	0.7
		03	08	1	0.5
		04	08	3	0.6
	01	00	00	4	32.2
		00	02	1	12.9
		00	08	1	6.9
	02	00	00	2	10.5
		00	03	2	4.2
		00	06	2	5.1
		00	08	4	10.9
	03	00	00	6	6.8
		00	03	1	2.3
		00	06	2	1.8
		00	08	14	14.4
	04	00	00	71	14.0
		00	03	1	0.2
		00	04	8	2.4
		00	08	114	26.2
	03	00	00	1	0.8
	04	00	00	8	1.8
		00	04	2	0.3
		00	08	8	1.3
	2 (Harahey)	01	00	08	1
		01	00	2	600.7
		01	01	1	442.4
		01	03	1	>500
		02	02	1	161.9
		03	04	2	441.0
		04	01	1	402.9
01`		00	02	5	354.7
		00	08	2	67.1
		01	00	2	108.0
		01	02	1	102.7
		01	03	1	31.1
		02	02	2	266.3
		02	04	1	88.3
02		00	00	2	10.1

*Archeological Testing of TxDOT Right-of-Way Along FM 580W Over Lynch Creek  
Lampasas County, TX - Texas Department of Transportation*

<b>Experimental Biface #</b>	<b>Size Grade</b>	<b>Cortex</b>	<b>Platform</b>	<b>Qty</b>	<b>Weight (g)</b>
		00	02	3	10.0
		00	04	1	11.6
		00	08	13	77.6
		01	08	3	86.8
		02	08	1	7.6
		03	08	2	10.1
		04	08	4	19.8
03		00	00	3	3.6
		00	02	5	12.2
		00	03	1	0.7
		00	04	1	1.5
		00	08	5	13.2
		02	08	3	5.0
		04	02	1	1.2
		04	08	1	2.2
04		00	00	14	31.0
		00	02	5	12.2
		00	03	1	1.1
		00	08	47	31.5
01		00	00	2	58.5
		00	02	8	105.7
		00	03	1	12.1
		00	04	6	102.2
		00	08	6	55.8
		01	08	1	32.4
		02	02	1	40.5
02		00	00	7	48.8
		00	02	4	19.2
		00	03	2	7.0
		00	04	1	3.6
		00	06	1	7.1
		00	08	9	15.0
03		00	00	11	18.9
		00	02	5	8.5
		00	03	4	6.9
		00	04	1	3.1
		00	06	1	1.0
		00	08	9	12.4
04		00	00	36	13.8
		00	02	16	9.4
		00	03	4	2.3
		00	04	1	0.4

Experimental Biface #	Size Grade	Cortex	Platform	Qty	Weight (g)
2 (Harahey) – continued		00	08	70	28.1
	01	00	00	1	6.5
		00	04	2	14.6
	02	00	00	2	7.9
		00	04	2	7.2
		00	06	2	4.5
		00	08	6	16.8
	03	00	00	13	15.2
		00	02	6	10.2
		00	03	2	2.1
		00	04	4	8.8
		00	06	5	8.3
		00	08	16	23.5
	04	00	00	51	19.0
		00	02	3	1.7
		00	03	6	2.6
		00	04	7	3.6
		00	06	4	2.0
		00	08	76	25.3
	15 (Friday)	01	00	01	1
		00	03	1	35.6
		00	08	2	34.6
		01	02	2	93.4
		01	08	3	93.4
		03	02	4	172.3
		04	00	2	64.1
		04	01	3	265.5
		04	02	1	54.3
02		00	01	1	6.4
		00	02	3	16.6
		00	03	1	3.4
		00	04	1	6.6
		00	08	1	15.1
		01	04	1	5.8
		01	08	3	24.4
		03	00	1	9.7
		04	00	1	3.3
03		00	00	6	6.3
		00	01	1	2.7
		00	02	1	2.0
		00	08	8	11.3
		01	00	2	3.1

*Archeological Testing of TxDOT Right-of-Way Along FM 580W Over Lynch Creek  
Lampasas County, TX - Texas Department of Transportation*

<b>Experimental Biface #</b>	<b>Size Grade</b>	<b>Cortex</b>	<b>Platform</b>	<b>Qty</b>	<b>Weight (g)</b>
		01	02	2	4.5
		01	08	2	2.7
	04	04	00	1	4.8
		04	01	2	1.4
		04	08	1	9.4
		04	02	4	3.0
		04	03	1	0.2
		04	08	33	14.2
	01	00	00	3	38.2
		00	01	1	19.7
		00	04	3	9.1
		00	08	5	39.6
	02	00	00	5	20.0
		00	04	2	10.3
		00	08	13	45.5
		03	08	1	3.2
		04	08	1	3.1
	03	00	00	7	8.9
		00	01	1	2.6
		00	02	4	4.2
		00	08	24	35.1
	04	00	00	37	12.8
		00	01	1	0.3
		00	02	4	1.3
		00	03	3	0.9
		00	04	2	3.5
		00	08	99	33.7
	01	00	00	1	6.0
	02	00	00	3	6.9
		00	02	1	1.8
		00	06	1	4.4
		00	08	7	17.8
	03	00	00	12	21.5
	03	00	02	2	1.9
	03	00	03	3	4.7
	03	00	04	2	2.3
	03	00	06	2	2.8
	03	00	08	15	13.3
	04	00	00	72	18.5
		00	01	1	0.7
		00	02	17	5.8
		00	03	5	3.3

15 (Friday) – continued

Experimental Biface #	Size Grade	Cortex	Platform	Qty	Weight (g)
15 (Friday) – continued		00	04	9	4.5
		00	06	1	0.4
		00	08	95	27.7
	02	00	04	1	1.0
	03	00	00	1	0.3
	03	00	08	2	1.6
	04	00	00	21	4.5
		00	04	1	0.1
		00	08	19	2.8
6 (Friday)	01	01	00	2	50.6
		01	02	2	27.4
		01	04	1	39.9
		02	00	1	91.7
		02	02	1	15.0
		02	04	1	26.2
		03	04	1	21.2
		04	08	1	13.3
	02	00	00	3	15.9
		00	04	1	5.5
		00	08	1	5.0
		01	00	3	14.1
		01	08	3	24.4
		03	00	1	7.1
	03	00	00	6	12.2
		00	02	2	3.1
		00	04	1	2.5
		00	08	3	7.7
		01	00	2	4.8
		01	08	1	3.0
		03	00	1	5.1
		03	02	1	2.5
		03	08	2	6.2
		04	00	1	1.1
		04	02	1	12.2
	04	00	00	14	6.0
		00	02	4	1.7
		00	03	1	0.3
		00	04	1	0.8
		00	08	31	15.9
	01	00	06	1	12.9
		01	08	1	14.8
	02	08	1	8.4	

*Archeological Testing of TxDOT Right-of-Way Along FM 580W Over Lynch Creek  
Lampasas County, TX - Texas Department of Transportation*

<b>Experimental Biface #</b>	<b>Size Grade</b>	<b>Cortex</b>	<b>Platform</b>	<b>Qty</b>	<b>Weight (g)</b>	
6 (Friday) – continued	02	00	00	1	4.0	
		00	06	1	3.0	
		00	08	3	10.1	
		01	00	2	7.0	
	03	00	00	11	15.6	
		00	02	3	8.1	
		00	03	1	1.2	
		00	04	2	3.2	
		00	06	1	2.1	
		00	08	9	12.9	
	04	00	00	53	20.9	
		00	02	3	1.0	
		00	03	3	0.9	
		00	04	4	3.4	
		00	06	1	0.3	
		00	08	56	15.6	
	02	00	00	3	2.4	
	03	00	00	2	5.3	
		00	06	2	3.8	
		00	08	5	5.3	
	04	00	00	22	4.7	
		00	02	1	0.2	
		00	04	2	0.7	
		00	06	3	0.9	
		00	08	16	3.0	
	12 (Gahagan)	01	00	01	1	3.3
			04	00	1	39.4
			04	04	2	150.9
02		00	01	3	5.7	
		00	08	1	1.9	
		01	08	1	1.6	
03		00	00	5	5.7	
		00	01	5	5.7	
		00	02	1	6.5	
		00	04	1	1.6	
		00	08	11	9.4	
		01	00	1	1.1	
		01	08	1	1.1	
		04	00	1	1.0	
04		00	00	8	2.6	
		00	01	32	8.8	
		00	08	52	14.7	

Experimental Biface #	Size Grade	Cortex	Platform	Qty	Weight (g)
		01	00	2	0.6
		01	08	2	0.7
		02	00	2	0.9
		02	08	2	0.8
		04	00	3	4.3
		04	08	8	5.6
01		00	00	1	18.7
		00	01	1	14.0
		00	08	1	15.8
02		00	00	1	2.7
		00	01	1	8.6
		00	06	1	7.1
		00	08	2	7.0
03		00	00	13	22.9
		00	01	1	2.4
		00	03	1	1.5
		00	04	1	1.5
		00	08	14	24.6
04		00	00	42	13.0
		00	01	5	1.4
		00	02	4	0.9
		00	03	6	1.9
		00	04	1	0.6
		00	08	80	27.5
		01	08	6	2.9
		03	08	1	0.1
		04	08	1	0.1
02		00	08	1	4.1
03		00	00	3	3.6
		00	06	1	2.5
		00	08	3	2.2
04		00	00	51	13.8
		00	03	2	0.6
		00	04	8	2.0
		00	06	1	1.3
		00	08	29	8.9