

Stephen F. Austin State University

SFA ScholarWorks

CRHR: Archaeology

Center for Regional Heritage Research

2017

Cave Winch: When a Looter's Tool Becomes an Artifact

Robert Z. Selden Jr.

Center for Regional Heritage Research, Stephen F. Austin State University, zselden@sfasu.edu

J Javi Vasquez

Follow this and additional works at: <https://scholarworks.sfasu.edu/crhr>



Part of the [American Material Culture Commons](#), and the [Archaeological Anthropology Commons](#)

[Tell us](#) how this article helped you.

Repository Citation

Selden, Robert Z. Jr. and Vasquez, J Javi, "Cave Winch: When a Looter's Tool Becomes an Artifact" (2017).
CRHR: Archaeology. 240.

<https://scholarworks.sfasu.edu/crhr/240>

This Article is brought to you for free and open access by the Center for Regional Heritage Research at SFA ScholarWorks. It has been accepted for inclusion in CRHR: Archaeology by an authorized administrator of SFA ScholarWorks. For more information, please contact cdsscholarworks@sfasu.edu.



Figure 1. 2013 excavations at Sierra Diablo Cave in Hudspeth County, Texas. The winch was located to the left of the vertical board (left) near the light.

CAVE WINCH: When a Looter's Tool Becomes an Artifact

ROBERT Z. SELDEN Jr. and J. JAVI VASQUEZ

As an archaeologist, it is often difficult to empathize with looters and collectors, but we would like to ask that you put aside any pre-conceived notions of judgment as we consider the question: when does a looter's tool become an artifact? For the two of us, this particular dialogue began in the summer of 2013 on an excavation at Sierra Diablo Cave in western Texas (Vasquez 2010). In that cave was a winch that we assume was constructed on or near the site as a tool for excavating deposits near the rear of the cave (Figure 1).

Based upon graffiti, it appears that the winch may have been a resident of Sierra Diablo Cave (Figure 2) for around 80 years prior to its removal during the 2013 field season. When the guano from the local bat population was carefully wiped away, numerous names, initials and dates that had been written on the winch became visible. While those names, initials and dates are of no consequence in this present discussion, they may be of interest in future dialogues.

THE CAVE WINCH

We assume that the winch was borne of recycled wooden parts from the local ranch, and that it was constructed in or near Sierra Diablo Cave. Due to the dry climate and the cool temperatures at the rear of the cave, the preservation of this piece is fairly remarkable. In the summer of 2013, the winch was removed from Sierra Diablo Cave (Figure 3) as excavations expanded and the potential contributions of this artifact were pondered.

Continued on page 23

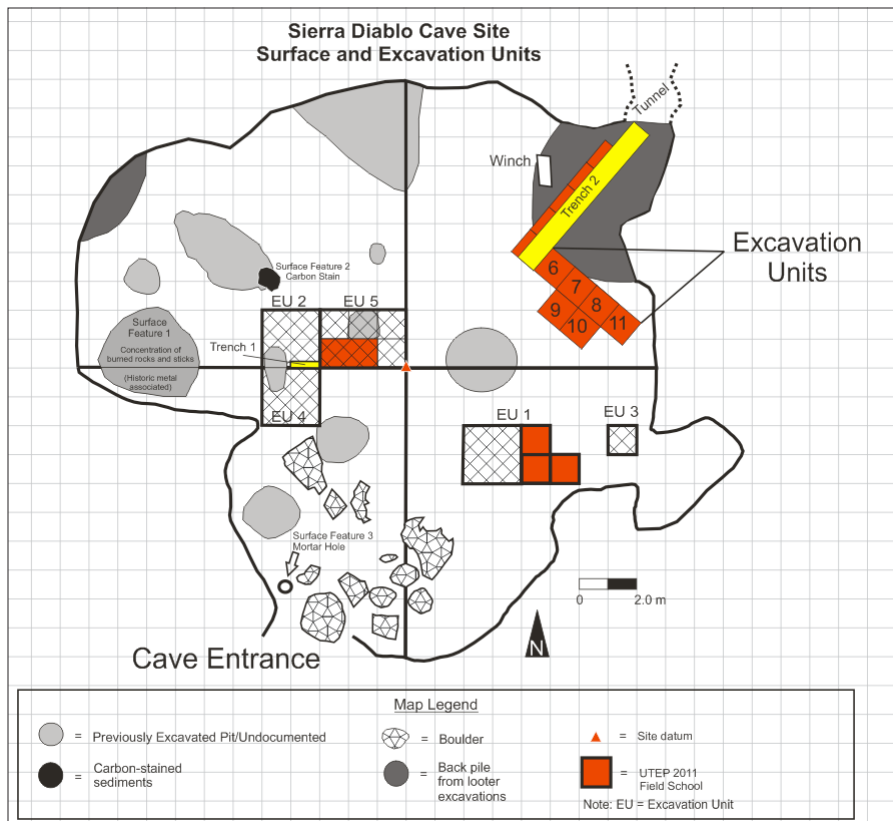
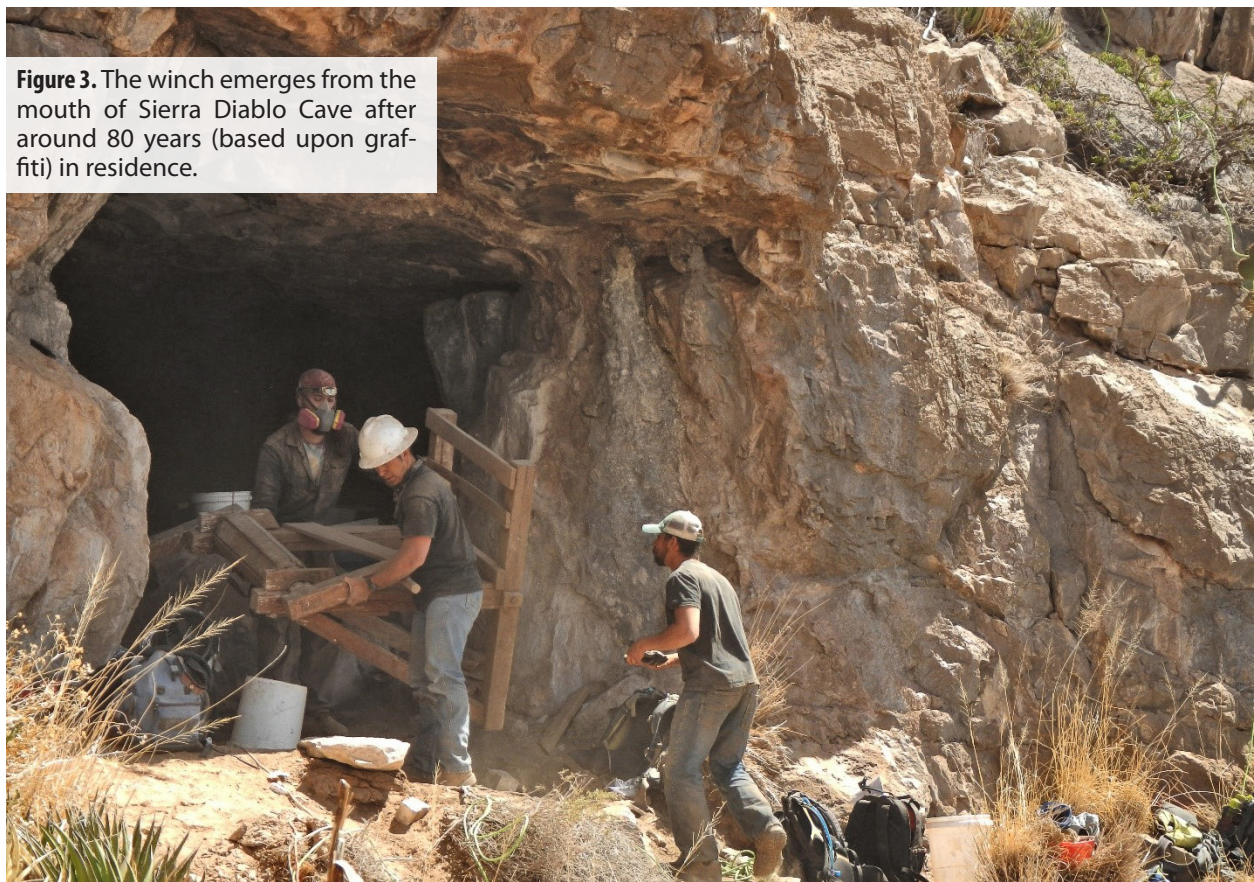

Figure 2. Location of the winch in Sierra Diablo Cave (Vasquez 2012: Figure 1).

Once removed, the physical characteristics of the winch were recorded (Figure 4), to include documentation of the graffiti that adorns it; primarily initials and dates. The two handles of the winch appear to be located too far apart for a single operator to use. This does not preclude the manipulation of the device by a single person; however, the size of this tool does indicate that its use may have been cooperative.

Further design-based evidence for cooperative use is evident, as the two angular supports connected to the base of the winch face toward the targeted excavation area. On the opposite side of the base is a platform—comprised of two horizontal boards—upon which either a

Figure 3. The winch emerges from the mouth of Sierra Diablo Cave after around 80 years (based upon graffiti) in residence.



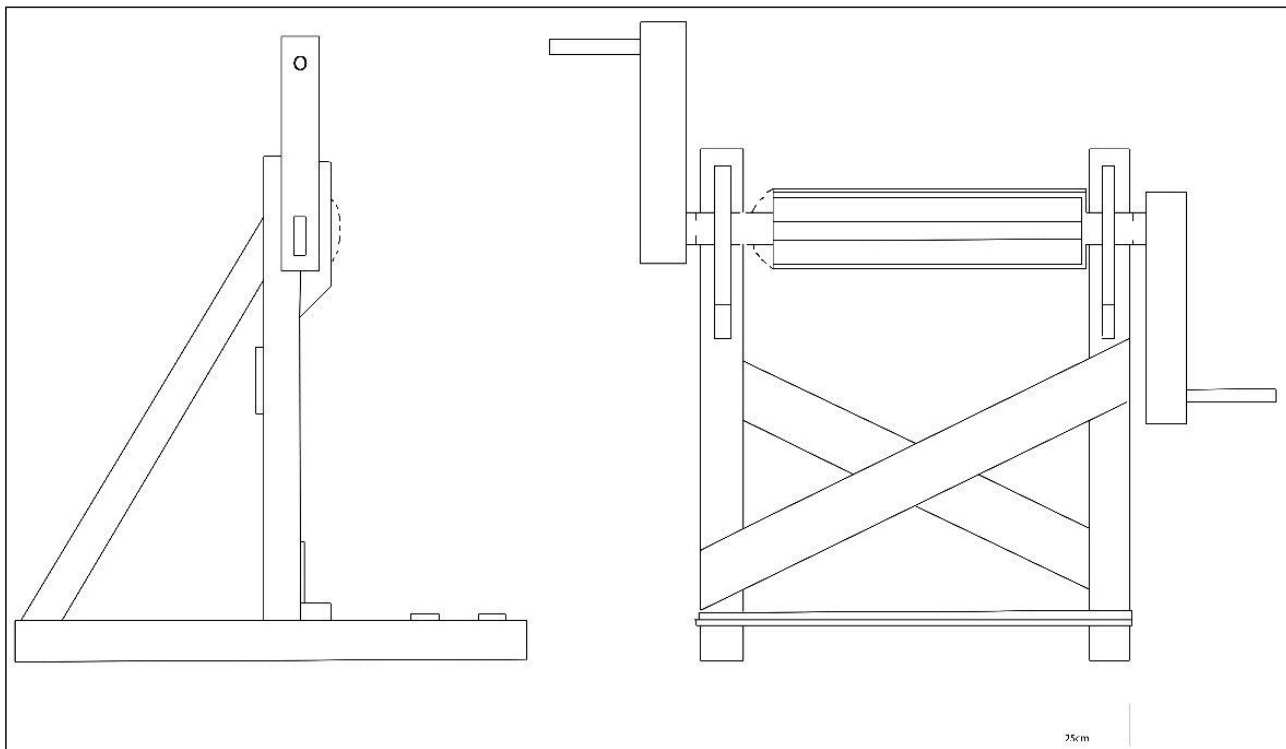

Figure 4. Schematic of winch recovered from Sierra Diablo Cave.

heavy object or the feet of a person might be placed. Having this weight on the winch would counterbalance the winch against the load, and reduce sliding along the cave floor where it might have impacted a variety of fragile (woven) artifacts that were recently found buried just beneath the surface.

SO WHEN DOES A LOOTER'S TOOL BECOME AN ARTIFACT?

The Sierra Diablo Cave winch became an artifact very soon after it was abandoned. The presence of this tool provides clues that help us to better understand and mitigate the patterns of damage that occurred at the cave, and the graffiti has the potential to provide a relative chronology of when that damage took place. In short, if a looter's tool can provide information that assists in better framing, characterizing and conceptualizing the events that transpired at a site, then it should be classified as an artifact.

Further, it is not necessary for an artifact abandoned by a looter to be a tool in order to provide useful information within the framework of an excavation.

In many cases, beer cans, coins and other elements of abandoned material culture that can be directly linked to looting activities can provide clues that help us to better frame our discussions regarding which deposits might be intact, and which may have been disturbed. In the case of the winch, we also have a clue as to how this disturbance occurred. This provides insight into the various damage patterns that we see at the site, where the bucket that was used in conjunction with the winch would quickly dig into the surface of the very fine wind-blown sediment that had been deposited on the cave floor.

SUMMARY AND CONCLUSION

In the case of tools and other material culture left behind by looters that can provide additional insight into the history of the site, we consider these to be artifacts. The information that can be garnered from the Sierra Diablo Cave winch places it within the realm of an artifact, since it can contribute a unique sequence to the site's history, providing an additional dimension to the interpretation. It is

Continued on page 25

still unknown how much of an impact this tool had on the site, but understanding the patterns of the bucket striations in unit profiles can provide some substantive clues as to the depth of the disturbed and intact deposits. From these data, we can get a better idea of the various locations in the cave where this winch was placed, and subsequently used. This information can then be used to identify areas of the site where subterranean deposits remain intact.

Further research into the graffiti on the winch may yield a useable chronology that might aid in documenting looting activities at the site. While the original location of the winch was recorded, mitigating damage to the site generated through the use of this tool is ongoing. That work will result in an assessment of site integrity and an overview of the history of site impacts at the Sierra Diablo Cave.

ACKNOWLEDGMENTS

We wish to thank the National Geographic Society for funding the 2013 field season, and Jordan J. Dew, Anastasia M. Hershey, Austin Kretzer, Jennifer Segovia, Karina M. Torres and William P. Turpin for their help with the excavation. The Sierra Diablo Cave winch is currently curated in the private residence of the landowner.

REFERENCES CITED

- VASQUEZ, JOSE J.
2010 Preliminary Archaeological Investigations at the Sierra Diablo Cave Site: PaleoIndian and Archaic Occupations in Hudspeth County, Texas. Unpublished MA thesis, Department of Sociology and Anthropology, University of Texas at El Paso.
- 2012 Sierra Diablo Cave: A Status Report. Paper presented at the El Paso Archaeological Society, El Paso, Texas.

ROBERT Z. SELDEN JR.
Center for Regional Heritage Research
Stephen F. Austin State University
Nacogdoches, Texas (seldenjr@sfasu.edu)

J. JAVI VASQUEZ
New South Associates, DeRidder
Louisiana Branch

★ 2017 ★ CALENDAR

REGION 1

Panhandle AS: 3rd Wednesdays except June-August
& December

REGION 3

Collin County AS: 2nd Tuesdays
Parker County AS: 3rd Thursdays except June-August
& November, December
Tarrant County AS: 2nd Thursdays

REGION 4

Deep East Texas AS: 1st Mondays
Valley of the Caddo AS: 3rd Tuesdays

REGION 5

Brazosport AS: 2nd Tuesdays except June
Fort Bend AS: 2nd Wednesdays except June
Houston AS: 3rd Thursdays

REGION 7

Coastal Bend AS: 1st Wednesdays

REGION 9

Central Texas AS: 2nd Thursdays except June-August
Llano Uplift AS: 2nd Wednesdays except June & December
Travis County AS: 2nd Thursdays except June & December

REGION 10

Concho Valley AS: 4th Thursdays
Iraan AS: Last Tuesdays
Midland AS: regularly scheduled special events

REGION 12

Archeological Institute of America: regularly scheduled lectures
Hill Country AA: 3rd Saturday Jan-March-May-July-Sept-Nov