

University of New Hampshire University of New Hampshire Scholars' Repository

Honors Theses and Capstones

Student Scholarship

Fall 2016

Improving the Efficiency and Resolution of Time of Flight (TOF) Mass Spectrometer for Magnetospheric Applications.

Zain Abbas

University of New Hampshire, Durham, zgu3@wildcats.unh.edu

Follow this and additional works at: <https://scholars.unh.edu/honors>

 Part of the [Engineering Physics Commons](#), and the [Plasma and Beam Physics Commons](#)

Recommended Citation

Abbas, Zain, "Improving the Efficiency and Resolution of Time of Flight (TOF) Mass Spectrometer for Magnetospheric Applications." (2016). *Honors Theses and Capstones*. 309.
<https://scholars.unh.edu/honors/309>

This Senior Honors Thesis is brought to you for free and open access by the Student Scholarship at University of New Hampshire Scholars' Repository. It has been accepted for inclusion in Honors Theses and Capstones by an authorized administrator of University of New Hampshire Scholars' Repository. For more information, please contact nicole.hentz@unh.edu.

Improving the Efficiency and Resolution of Time of Flight (TOF) Mass Spectrometer for Magnetospheric Applications.

Zain Abbas

Department of Physics, University of New Hampshire, Durham, NH

May 24, 2016

Abstract

The Earth magnetosphere is the volume of space formed by the Earth magnetic field in response to the flow of plasma from the solar wind. Although the magnetopause shields us from the solar wind, there is still an interaction, and particles penetrate with energy, and momentum into the Earth's magnetosphere and interact with the Earth's magnetic field to create various plasmas and currents in the magnetosphere. The study of the dynamics of ions in and outside of the magnetosphere is done through mass spectrometry. For more than 15 years the CLUSTER/CODIF provided outstanding data to understand the interaction of the solar wind with the magnetosphere. This detector uses a Time-Of-Flight (TOF) detector, which provides the composition and the 3D ion distributions for hydrogen, helium and oxygen. However, the efficiency of the CODIF decreased with time due to reduced gain of the Micro Channel Plates (MCP) detectors. In this study, we have tested three different configurations of the MCPs in the instrument and determined both the output charge from the MCP and the efficiency of the overall instrument. This study will be used to optimize the design of sensors which will be flown on future missions. Here I present the results of this study to determine the optimum MCP configuration.

1. Introduction

The charged particles and the magnetic field from the Sun interact with the Earth's magnetic field and create a cavity around the Earth called magnetosphere. Few energetic charge particles mainly hydrogen and helium penetrate through the magnetosphere and enter into the Earth's magnetic field through polar cusps. Similarly, few of the particles travel from the magnetotail and enter into the Earth's ionosphere by acceleration due to magnetic reconnection. These particles get ionized and create aurora on the surface of the Earth atmosphere [1]. Likewise, the emission of nitrogen and oxygen ions from the ionosphere also contributes to the total composition of plasma in space. To understand the composition of plasma in our magnetosphere, we need to observe the interaction of solar wind with the Earth's magnetic field. Thus, using mass spectrometer we can measure the mass per charge ratio of the ions to improve our understanding of the magnetospheric plasma. Previously, Composition Detection of Ion Function Analyser (CODIF) instrument part of Cluster mission provided us with the composition and 3D distribution of ions in our magnetosphere. However, with the old CODIF we can only see the hydrogen, helium and oxygen ion in space. Therefore, using new MCP configuration and better electronics we will improve the efficiency of the existing CODIF to analyze the new ions both from the ionosphere and the Sun.

2. Historical Perspective

Understanding the plasma in space has always been an active area of research in space physics. On July 16th and August 9th 2000, the Cluster mission launched two sets of satellites in space to collect data on the interaction of solar wind with the Earth's magnetosphere [3]. The four satellites form a tetrahedral formation that provided the three dimensional structure of the space plasma in our magnetosphere.[3]

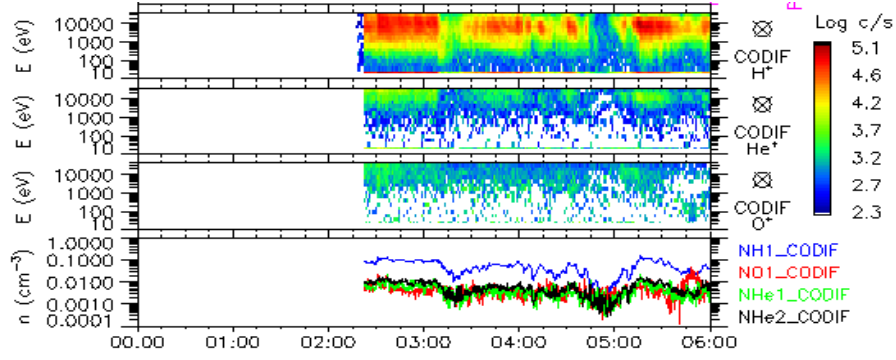

Figure1: The first three plots show the counts per second of the H+, He+ and O+ from energy E (10ev-10 kev). The bottom plot shows the density of the ions at different times. All these quantities are derived from the Time of Flight (TOF) spectrum [4].

Over the 15 years, Cluster has provided us with data to examine the interaction of solar particles with the Earth magnetic field. The data has allowed scientist to make models of the magnetosphere to better understand the processes taking place inside it.

3. The Sun

The Sun is classified as a main sequence star according to Hertzsprung-Russell (H-R) diagram. It has a radius of $7 \cdot 10^{10}$ cm with a mass of $2 \cdot 10^{33}$ g. It is mainly composed of about 90 % hydrogen and 10% helium. The Sun produces the energy through a continuous transformation by nuclear fusion of hydrogen into helium inside the nucleus. In the first step, the two hydrogen nuclei or two protons combine to form a nucleus of deuterium D^2 (1 proton and 1 neutron), a positron e^+ and a neutrino ν [5]. The following equation shows the first step of nuclear fusion:



In the next step, the deuterium combines with a proton to form a helium nucleus He^3 and electromagnetic radiation gamma ray.



In the final step, the two reactions described above produce two He^3 nuclei, which then fuse into one He^4 nucleus (2 protons plus 2 neutrons) and two hydrogen nuclei H^1 :

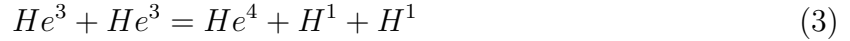

The final result produces 4 protons and 2 neutrons with a kinetic energy difference between initial and final mass. The energy from the core is then transmitted and absorbed through radiative zone. After that the convective zone is responsible to transmit the energy to photosphere. The photosphere is the outermost surface of the Sun. Through this region, the photons are able to escape from the Sun without any further absorption and scattering in the form of solar wind.

3.1. *The Solar Wind and Corona*

The solar wind is a stream of charged particles mainly composed of electrons and protons, flowing outward from the Sun. The wind also carries a magnetic field of the Sun, which controls the pressure of the magnetosphere. The solar wind is erupted through the corona which is the outer most layer of the solar atmosphere and has a high temperature of about 2×10^6 K [5]. The corona is supported by the gravitational force of the Sun and the force from the difference in pressure above and below it. It stretches far out in space and reaches the Earth's orbit. The shape of the corona is determined by the Sun's magnetic field.

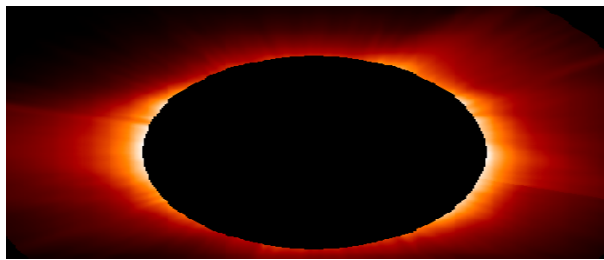

Figure 2: The above figure shows the Sun's corona captured by the SOHO satellite. The corona is a plasma that surrounds the Sun and other celestial bodies. The bright white lines near the surface of the Sun

are coronal mass ejections and an irregular shape around the Sun represents the corona itself.[7]

4. Interaction of the Solar plasma with the Earth magnetic field:

4.1. *The Magnetosphere*

The solar wind carry charged particles and Sun's magnetic field that create a bow shock in front of the Earth. These particles create a cavity around the Earth called magnetosphere. The boundary at which the ions interact with the Earth magnetic field is called magnetopause. The region between the magnetopause and bow shock is called magnetosheath. Particles with high energy and momentum penetrates through the cavity unimpeded, while particles with less energy are deflected around the magnetosphere and travel towards the magnetotail [1].

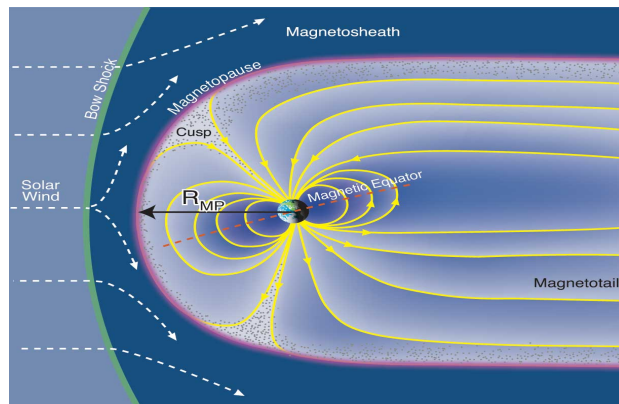

Figure 3: The above figure shows the magnetosphere of the Earth in response to solar plasma. The magnetosheath is a region between bow shock and magnetopause. The magnetotail is a region where the earth magnetic field combines and form a tail.

4.2. *Ions entering the magnetosphere*

The particles that interact with the Earth magnetic field enter into the magnetosphere and reaches the Earth's atmosphere through polar cusp. Similarly, particles that are deflected around the magnetic field transverse along the magnetic lines toward magnetotail and through magnetic reconnection enter into the Earth's atmosphere. These particles collide with the gaseous particles suspended at upper atmosphere of the Earth and create aurora on the northern and southern hemisphere of the Earth. In addition to that, there are few particles mainly composed of H, H⁺, He⁺⁺ and He⁺ are suspended inside the Earth's magnetosphere and creates different currents when interact with the Earth magnetic field. The ions emitted from the ionosphere of the Earth, which are mainly composed of O⁺ and N⁺ also contributes to the total plasma in space. Thus, it is essential to analyze the magnetospheric plasma to enhance our knowledge about the interaction of the solar wind with the Earth's magnetosphere.

5. Methodology

The plasma in Earth magnetosphere plays a vital role in affecting the human activities on Earth and in space. In order to study the plasma, which is accumulated both from the solar wind and Earth's ionosphere we use mass spectrometer to examine the mass per charge of the ions. Previously, the Composition and Distribution Function Analyzer (CODIF) which was part of Cluster mission has been used to analyze the ions in space. Due to the aging of the MCP's, the gain of the MCP decreased significantly over time. In principle, the gain of the MCP could be increased by increasing the voltage across the MCP. However, the geometric factor of the instrument and MCP configuration itself limit the effectiveness of raising the voltage. Therefore, it is essential to understand the structure of the MCP and different configuration of the MCP to improve the efficiency of the instrument [8]. Initially, we tested three different configuration the original CODIF, a single MCP and a chevron, and

two single MCP's. For each test, a TOF spectra was collected over the operational voltage range.

5.1. Original CODIF

The original CODIF consists of four main parts: a spherical shell entrance called Electro Static Analyzer (ESA), a carbon foil, a stack of MCP called chevron and an anode. The ions enter the instrument through a spherical entrance in the ESA, which filters the ions based on their energy per charge ratio. After the ions are filtered, they are given a Post Acceleration voltage (PAC) to go in the TOF section. When the ions interact with the carbon foil they knock out secondary electrons that are steered with an electric field to initiate start and position signal by hitting at one end of the MCP. The ions penetrate through the foil and hit the other end of the MCP giving a stop signal.

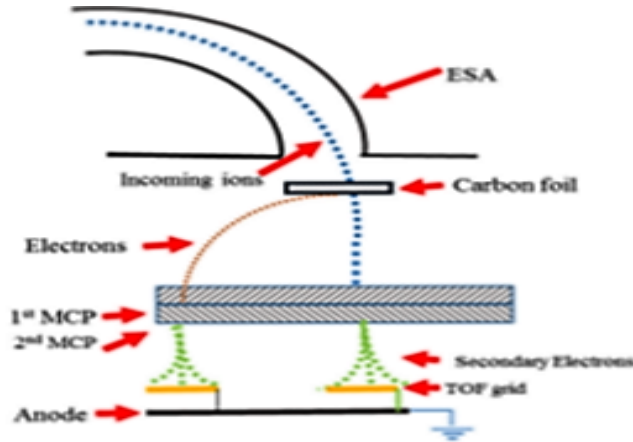

Figure 4: The above figure shows the original CODIF configuration. The two MCP's are stacked together called chevron.

Using the energy from ESA and time from TOF section, we calculated the mass per charge of an ion from the equation below:

$$E_{total} = \frac{1}{2}mv^2 \quad (4)$$

where $E_{total} = \frac{E}{Q} + PAC$. Solving for $\frac{M}{Q}$ give us

$$\frac{M}{Q} = \sqrt{(2E_{total}v)}\alpha \quad (5)$$

where α represents the effect of energy loss in the carbon foil, which is at the entry of the TOF section.

5.2. *Electro Static Analyzer (ESA)*

The ESA has a toroidal shape that is divided into 180° sections. It consists of inner and outer deflectors, a top hat and a collimator. The inner deflector consists of torodial and spherical sections which is connected at the entrance opening at an angle 17.9° . The outer deflector covers the whole torodial sector of the ESA. The top hat consists of a spherical section which fits inside the entrance of the outer deflector [6]. Moreover, the collimator defines the acceptance angles and deflects ultraviolet light from space. The cylindrical symmetry of the analyzer provide us with an isotropic response over 360° . The position and the incident angle of the ions are identified with the help of start signals in one of the 16 channels which are separated at 22.5° each. Analyzing the position signals could help us to examine the distribution of ions in space. [6]

5.3. *Carbon foil*

Ions passing through ESA, hit a thin layer of carbon sheet called carbon foil. The carbon foil is approximately $3\mu\text{g cm}^{-2}$. The ions lose energy when they interact with the carbon foil. Using the Stopping and Range of Ions in Matter (SRIM), the ions stopping energy could be determined when they interact with carbon foil. [6]

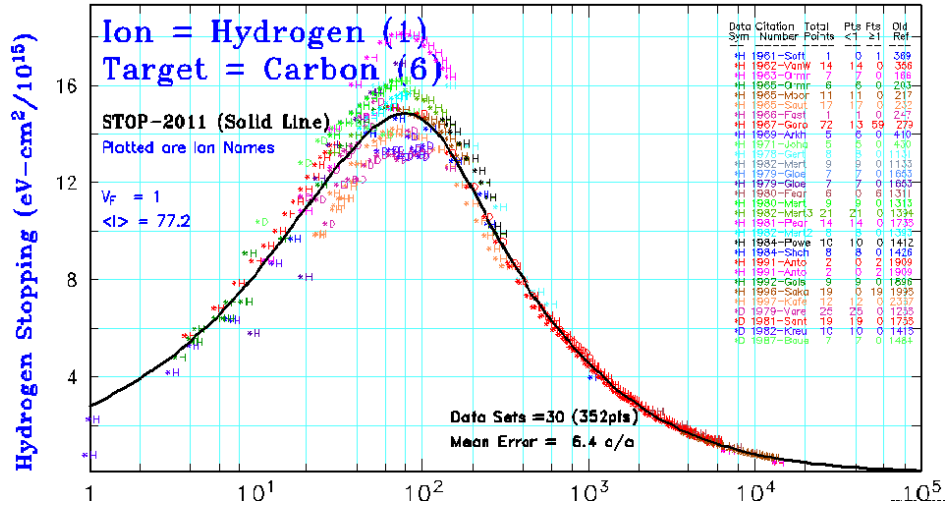

Figure 4: The above figure shows the energy spectrum of hydrogen ion when it interacts with the carbon foil. The hydrogen stopping energy is maximum at 10^{15} ev cm-2 and it decreases as the ion energy increases.

When an ion hit the carbon foil they knocks out the electrons, which are steered down through an electric field to hit MCP.

5.4. Micro Channel Plate (MCP)

MCP is an electron-photon multiplier plate. It has a lead silicate crystalline structure that is held at a variable voltage. The channels are approximately 10 um wide that run along the width of the material. MCP is usually coated with either an alkali halide compound. Each plate is manufactured with a specific density and a bias angle which is less than 10° .

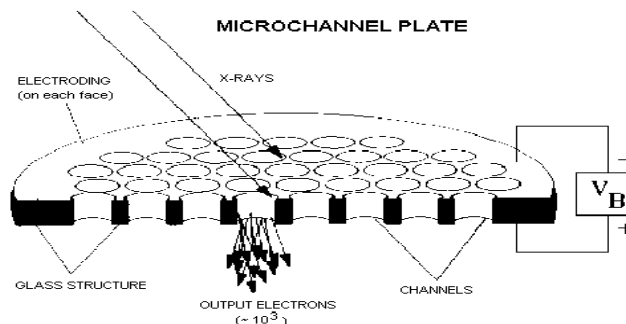

Figure 5: The above figure shows the cross section of the MCP. An incident x-ray photon interacts with the MCP which is held at variable voltage and produces 10^3 electrons.

When an incident ion interacts with MCP plate, it transfer its kinetic energy into valence electrons inside the MCP. If the ground state ionization energy of the incident ion is greater than the work function of the lead-silicate, it knocks out the free electron from the surface of the MCP. The free electron follows a parabolic trajectory and hits the wall of the MCP, creating an electron cascade. Therefore, by controlling the potential difference across the MCP, the multiplication of events can control the gain of the MCP. Another important aspect of the MCP is an area of collision for electron multiplication. The process is called dynodisation. Dynodisation inherently focuses on electrons and its interaction with the MCP pore.

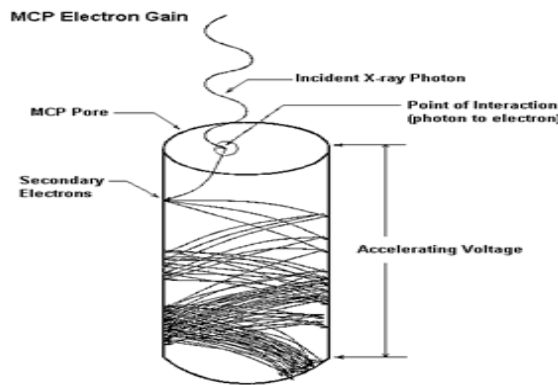

Figure 6: The above diagram shows the dynodisation effect on secondary electrons. The photon hits the MCP pore and transfer its velocity to an electron. The electron follows the parabolic path and collides with the wall of the MCP producing secondary electrons.

The internal electric field steers the electrons into the walls with enough energy to cascade electrons. As a result, the interaction of secondary electrons with the wall give rise to multiplication of electrons, which shows that MCP serve as an amplifier regardless of energy of incident ion. It also shows that MCP is a best candidate for electron-photon multiplication.[9]

6. CODIF Configurations

To improve the efficiency of the existing CODIF, we modified the MCP configuration and analyzed the TOF and efficiency spectrum for each configuration.

6.1. Original CODIF

The original CODIF consists of two MCP plates in a stack together. The chevron is operated at 3000V. The distance between the carbon foil and chevron is 3 cm. Over the years, the Cluster has provided us with significant data to analyze the interaction of solar wind with the Earth magnetic field. However, the gain of the MCP decreases significantly over time, which also decreases the efficiency of the instrument. In order to obtain an optimum gain, the ions should output a signal large enough to be measured. In reality, the gain of the instrument could be increased by increasing the voltage across the MCP, but the MCP geometry and the high voltage at the chevron limit the effectiveness of raising the voltage. Therefore, we modified the CODIF configuration to improve the gain and efficiency of the instrument over time.

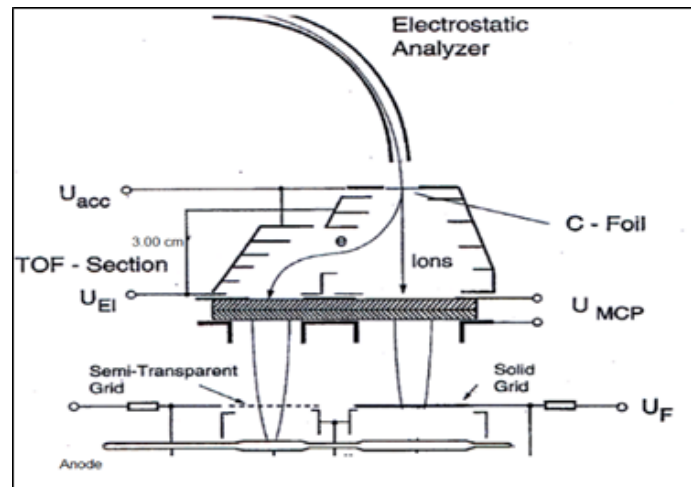

Figure 7: The above figure shows the original CODIF which is currently in space.

6.2. Single and Chevron stack

In the second configuration, we introduced a single MCP after carbon foil and placed a chevron 2.4 cm from the single MCP. The top MCP was operated at 1190V and the chevron was operated at 2300V. The ground consists of an anode which neutralizes the ions and electrons.

With this configuration, we obtained a pulse large enough to be measured for TOF spectrum. However, when an electron hits the single MCP, and creates a shower of one million electrons, those electrons enter the chevron and generate an intense noise form the MCP. Therefore, this configuration carries too much gain to handle.

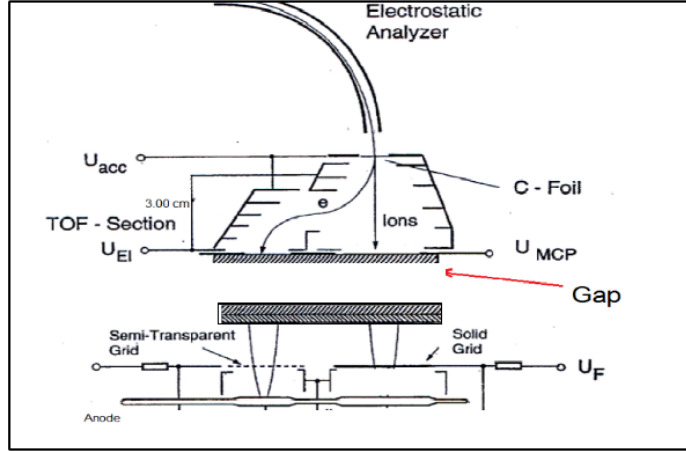

Figure 8: The above diagram shows a single MCP and chevron placed at 3cm with a ground supported by anode.

6.3. Two Single MCP's

In our third configuration, we replaced the single and chevron MCP with single MCPs. At the bottom, we also introduced a solid aluminium anode cover to reduce the high frequency noise from the MCP. With this configuration, we successfully obtained an optimum gain to analyze the pulse. Also, the anode cover at the bottom diminished the noise from the MCP and electronics.

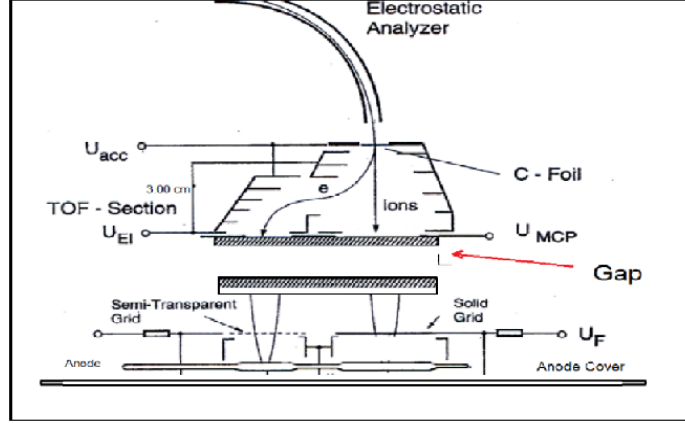

Figure 9: In the above figure, the two single MCP's are introduced with a 2.4cm gap in between and an anode cover to reduce the high frequency noise signals

For each configuration, we examined the TOF spectrum and compared it with theoretical values.

7. Results

In order to understand the importance of each CODIF configuration, we tested each modification by comparing its TOF with theoretical results. Using the kinetic energy formula, we derived the formula for time.

$$E = \frac{1}{2}mv^2 \quad (6)$$

$$v = \frac{L_{TOF}}{t} \quad (7)$$

plugging v in kinetic energy formula and solving for t

$$t = L_{TOF} \sqrt{\frac{M}{2E}} \quad (8)$$

From equation 8 we calculated theoretical TOF for each ion specie.

Ion	PAC = 10 keV	PAC = 12.5 keV	PAC = 15 keV	PAC = 20 keV
H+	24.6 ns	22.0 ns	19.2 ns	15.3 ns
H2+	34.8 ns	31.1 ns	27.2 ns	21.6 ns
O+	98.1 ns	87.7 ns	76.5 ns	61.2 ns

Table1 shows the theoretical values of TOF for each ion specie operated at different PAC voltage.

Similarly, we also examined the efficiency for each MCP configuration by taking the ratio of conversion ready and start. The conversion ready signals measure the number of start signals that are followed by a stop within 250 ns. Taking all these events and dividing by start signals gave us an efficiency for stop signal.

7.1. *Original CODIF*

In Figure 10, the spectrum has two peaks. One at 20 ns representing hydrogen TOF and the other one at 110 ns representing oxygen TOF. The small peaks shows the noise and gain signal from the MCP's. Since the electron pulse from the chevron goes across the high voltage, it created a lot of gain in our spectrum. In order to reduce the gain and improve the TOF spectrum, we tested our second configuration and compared its result with theoretical values.

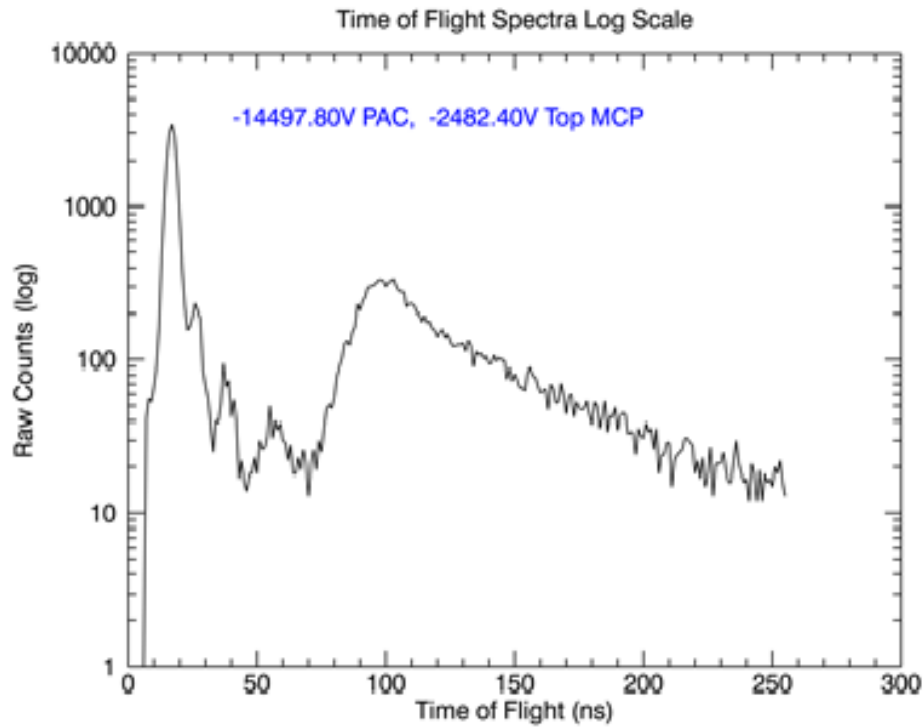

Figure 10: The above plot shows the TOF spectrum for original CODIF obtained at 15 keV PAC.

Similarly, Figure 11 shows the efficiency of the original CODIF obtained at various MCP voltages. The efficiency reaches up to 0.8 and forms a plateau, which marks the maximum efficiency of the instrument with increasing voltage. With the CODIF configuration, the efficiency of the instrument could be improved by increasing the voltage across the MCP, however it also increases the gain of the instrument and we get a large pulse to analyze. Therefore, in order to improve the efficiency of the instrument, we calibrated and tested second configuration and analyzed the TOF and efficiency spectrum.

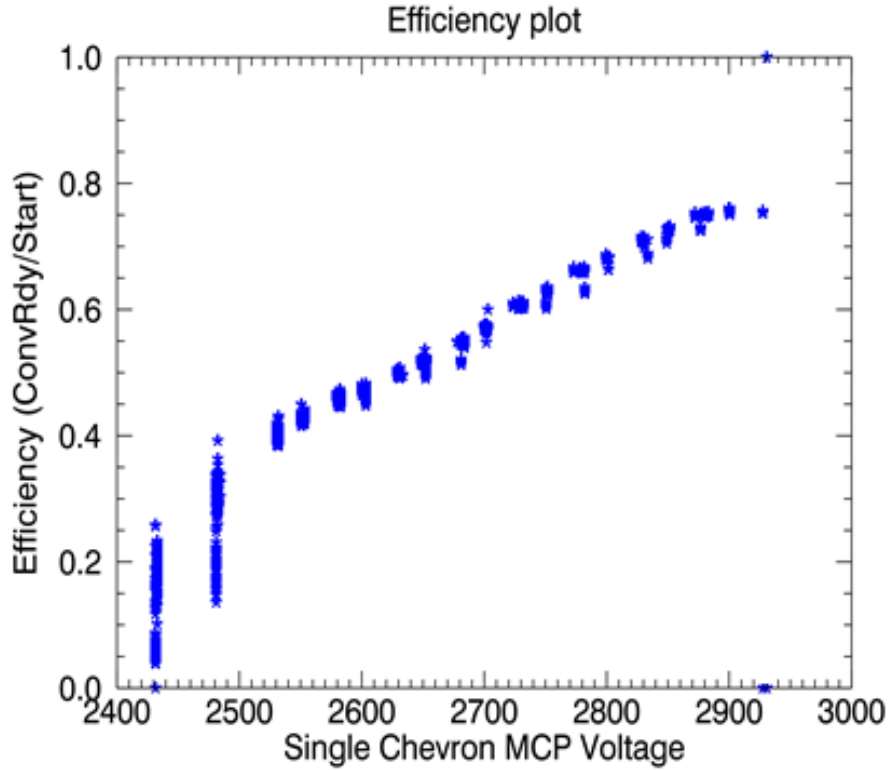

Figure 11: The above plot shows the efficiency of the original CODIF. As the chevron voltage increases, the efficiency increases until it reaches its maximum at 0.8.

7.2. *Single and Chevron stack*

In second configuration, we obtained two major peaks at 20 ns and 100 ns. Comparing these values with table 1, we observed that the plot has an offset. It is due to the fact that the ions especially heavy ions lose their energy when they interact with the carbon foil, thus shifting the TOF spectrum. Also, the plot has some significant peaks between 20 ns and 100 ns. One of the reasons behind these peaks is that the ions are moving at high voltage which generates electromagnetic signals. These signals are combined with the gain of the MCP and creates different peaks in the spectrum.

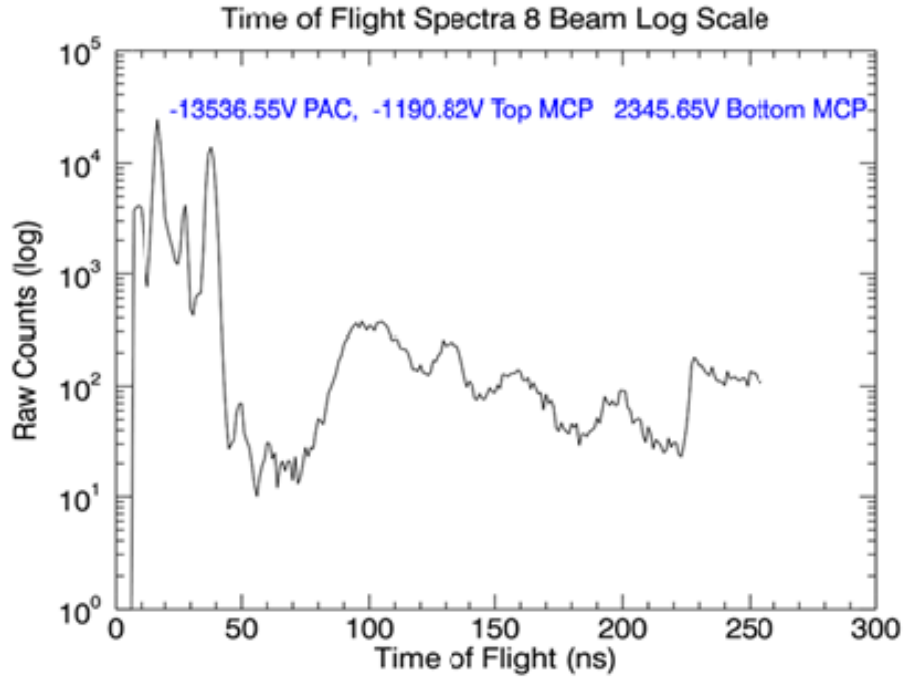

Figure 12: The above plot shows the TOF spectrum of the second configuration obtained at 13 keV PAC.

In Figure 13, the efficiency of the instrument has decreased to 0.6. Since the ions are moving at high voltage, increasing the voltage could generate enough power to trigger the high voltage power supply. Therefore, with single and chevron configuration, the MCP's are operated at moderate voltage to reduce the risk of damaging the instrument, which decreases the efficiency of the instrument.

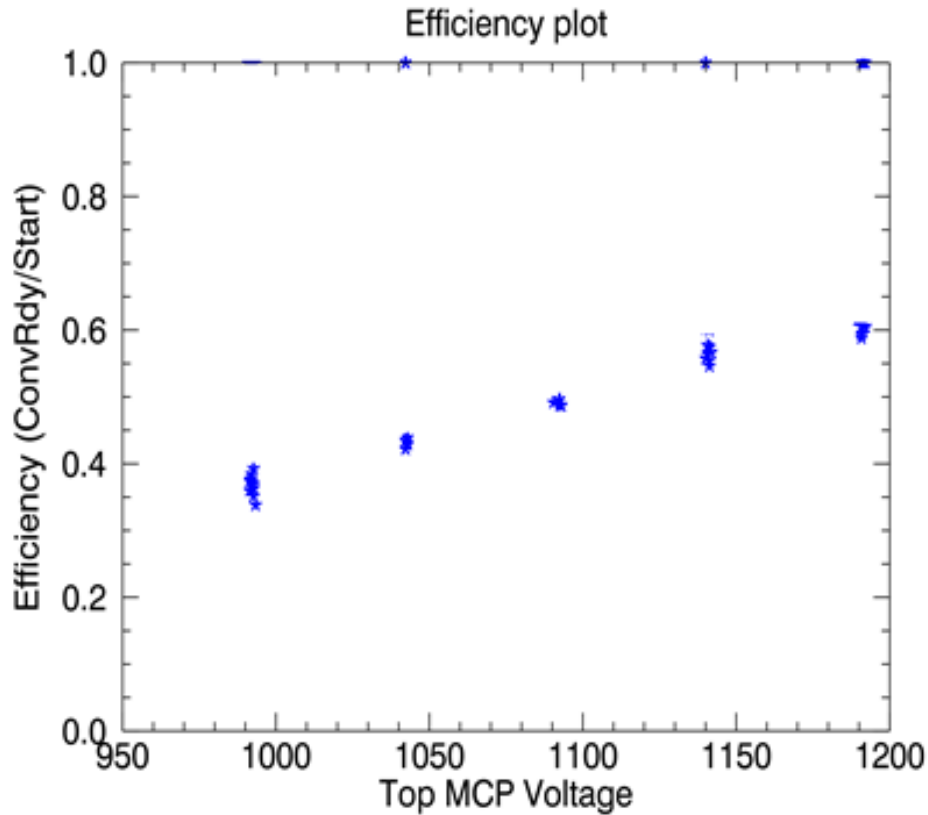

Figure 13: The efficiency of the instrument reaches up to 0.6 as the voltage of the single and chevron MCP increases. Since the electrons are travelling at high voltage, increasing the MCP voltage could damage the instrument

7.3. Two Single MCP's

Figure 14, represents the TOF spectrum for oxygen ion. For this specific configuration, we introduced a new ion gun that could shoot specific ion specie at the instrument. In Figure 14, we can see that at 20 kev PAC voltage there is one main peak at 120 ns. The spectrum is more stable with less background noise. The high gain from the MCP has been reduced significantly because of the MCP configuration. Also, the high frequency signals are weakened because of the solid aluminium foil cover, which reflected the high frequency noise back to the instrument and produced a clean signal with optimum gain. However, there is an offset at 61.2 ns. It is due to the fact, that the heavier ions would scatter and loose more energy

when they interact with the carbon foil, which shifts the TOF spectrum.

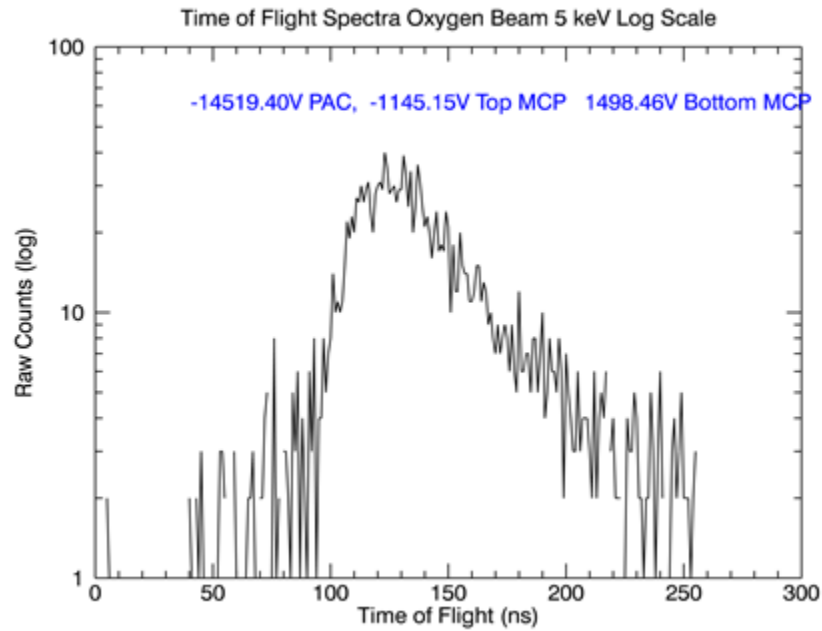

Figure 14: The above plot shows the TOF for oxygen at 20 keV PAC. The signal is much stable with a sharp peak around 120 ns

The figure below shows the efficiency for the two single MCPs. Comparing to the last two configurations plots, the maximum efficiency has dropped to 0.4. Since the top MCP is operated at low voltage, not a lot of electrons accelerated from the MCP and the gain is so low. Therefore, increasing the voltage would probably increase the electron counts and efficiency of the instrument.

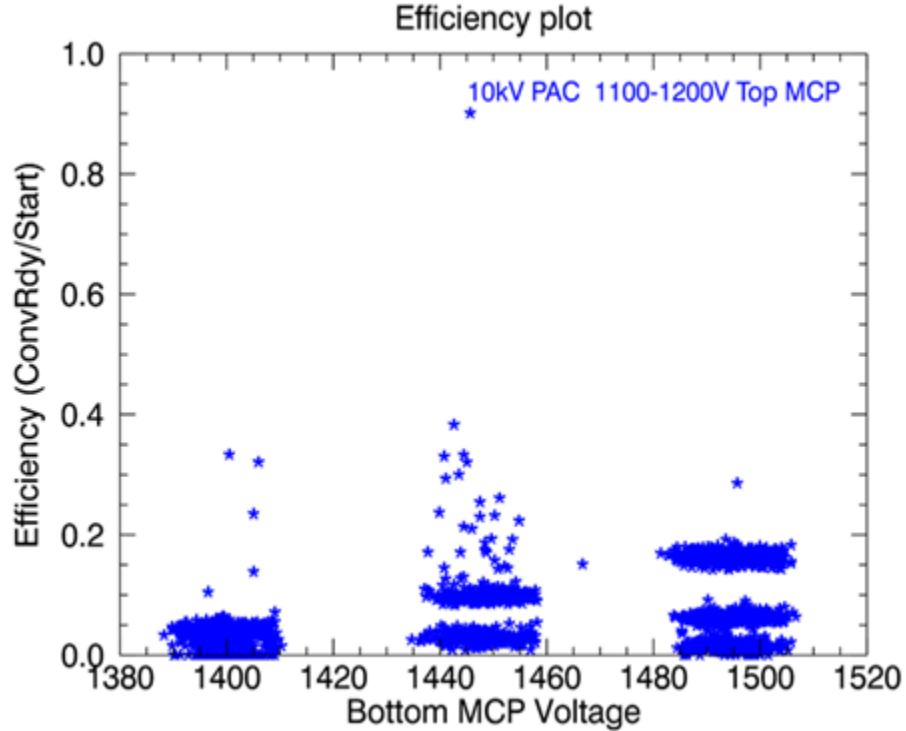

Figure 15: The above plot shows the efficiency of the two single MCP, obtained at 10 keV PAC. The efficiency of the instrument rises from 0 to 0.4, as the top and bottom MCP voltages rise.

7.4. Species Dependent Efficiency

Using the new ion gun, we examined the efficiency of the instrument by shooting carbon, oxygen, nitrogen, argon and helium ions to the instrument. In Figure 16a, we can see that at 15 keV PAC the heaviest ion which is the argon, has the lowest efficiency at 0 and the lightest ion, the helium has the highest efficiency at 0.12. Similarly, in Figure 16b the efficiency of the ions have been decreased, because the PAC is operated at 10 keV, giving less energy to the ions to travel to the MCP. In addition to that, the heavier ions scatter and get stuck at the carbon foil and only few of them penetrate through the foil and hit MCP. The loss of particles due to scattering could also affect the efficiency curve.

Moreover, according to the Figure 16 (a,b) the efficiency of the nitrogen ions is greater than the oxygen ions. It is probably due to excess of nitrogen molecules in ambient air than

oxygen, making total composition of nitrogen more significant than oxygen.

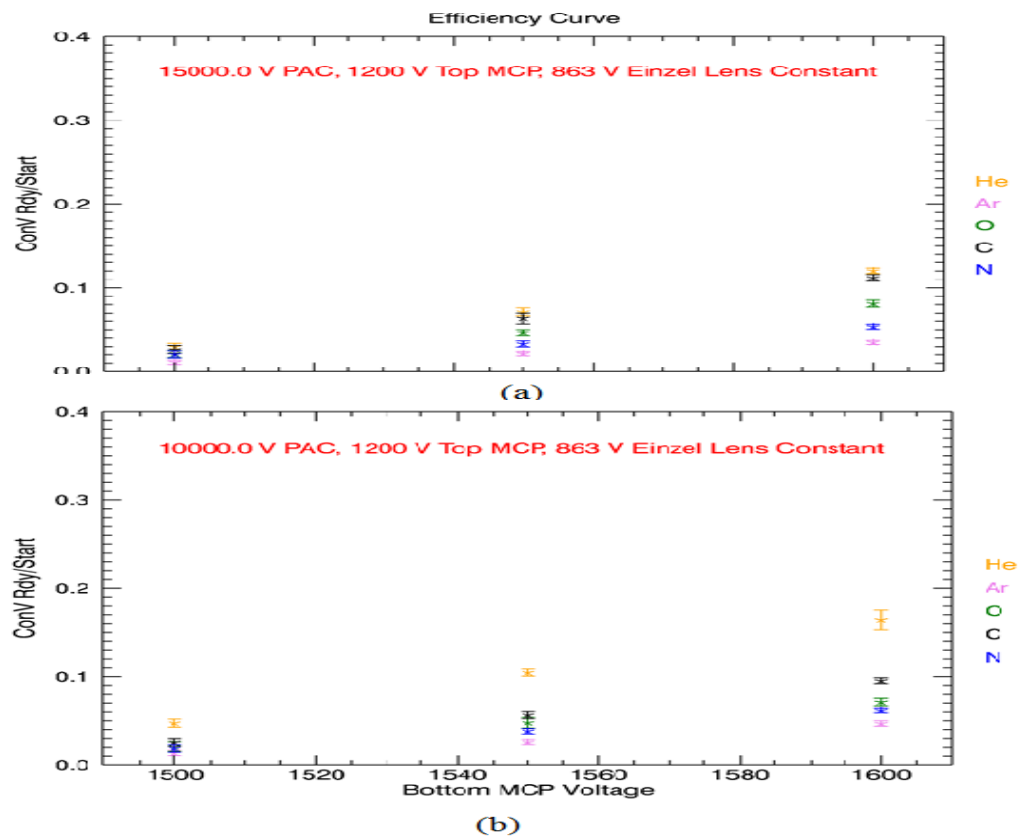

Figure 16: The above plot shows the efficiency curve for different ion species. In part a the efficiency of the ions increases since the PAC is operated at 15 kev. In part b, the efficiency of the ions decreases as the PAC voltage decreases to 10 kev. In both plots, the heavy ions have the lowest efficiency and the lighter ions have the highest efficiency

8. Discussion

Overall, the research project went well. We tested three configurations of the MCP to improve the efficiency of the instrument. Starting from the original CODIF, the stack of MCP was placed at 3 cm from the carbon foil and operated at 3000 V. Since the gain was too high and not uniform across the MCP, it limited the effectiveness of increasing the voltage across the MCP stack. Therefore, in the second configuration, we used a single MCP and stack of MCP at the bottom. With this setup we obtained a large pulse, but the noise

from the electron radiation also increased significantly with the voltage. Thus, in our third configuration, we used two single MCP's with a gap of 2.4 cm in between. This specific setup created flexibility for increasing the voltage across the MCP. To analyze each configuration, we obtained TOF and efficiency spectrum at each PAC voltage.

In all TOF spectrum's there is an offset from the original value. It is because of the scattering of ions at the carbon foil, which delays the start and stop signals and give an offset in TOF spectrum. Similarly, the random peaks in the spectrum is due to electromagnetic frequencies produced when the electron travels under high voltage. Likewise, the gain from the chevron also generated noise which is picked up by the instrument. However, in our last configuration we successfully reduced the high frequency noise by using the two single MCP's and an anode cover.

Moreover, we also compared the efficiency of the instrument for each modification. For original CODIF, the efficiency increases pretty well up to 0.8 and reaches a plateau. The high voltage across the MCP stack, restricts the limit on increasing the voltage in order to improve the gain and efficiency of the instrument. For second configuration, the efficiency decreased to 0.4 due to the high gain of the MCP. In the last configuration, we obtained an optimum gain and a reasonable signal to analyze the efficiency curve. Once we figured out the correct configuration of the MCP, we tested the efficiency of the instrument by shooting different ion species. From Figure 16 (a,b), we can see that the elements are arranged according to their respective atomic masses. The lighter elements have the highest efficiency and the heaviest elements have the lowest efficiency, but nitrogen has less efficiency compared to oxygen. Since the ambient air is mainly composed of nitrogen than oxygen, we get more particles for nitrogen ions, making it heavier than oxygen.

In a nutshell, we successfully enhanced the TOF spectra by changing the MCP configuration which would help us to find the composition of ions in magnetosphere. In future, we will increase the MCP voltage to find the maximum efficiency of the two single MCP's. Once, we have obtained the maximum efficiency we will use the instrument to analyze the

plasma in space.

9. Conclusion

In this project, I helped to improve the efficiency of the mass spectrometer to analyze the composition of plasma in our magnetosphere. We tested three different configurations by comparing the time of flight values with the theoretical values. Similarly, we examined the efficiency spectrum for each configuration to enhance our understanding about the MCP configuration. In future, we will use MCP instead of carbon foil to minimize the scattering of ions at the entry of TOF section. In this way, we can remove the offset from the TOF spectrum. Moreover, we will use a coating of Al_2O_3 and MgO to improve the production of secondary electrons inside the MCP, which would increase the counts of electrons per second and would eventually improve the efficiency of the instrument. All these changes would help us to analyze new ions, specifically O^+ and N^+ ions in magnetosphere.

10. Reference

- [1] Russell.C.T. "The Solar Wind Interaction with the Earths Magnetosphere: A Tutorial." Department of Earth and Space Sciences and Institute of Geophysics and Space Physics University of California Los Angeles. 5/17/16.
- [2] Bosqued, Sauvaud, Cros, Dandouras. "The Cluster Ion Spectrometry Experiment." Cluster: Mission, Payload and Supporting Activities. Vol. 1159, 1993. 5/17/16.
- [3] Cluster II operations. ESA. http://www.esa.int/Our_Activities/Operations/Cluster_I_Operations.
- [4] Web Server for the CIS Experiment Onboard the 4 CLUSTER Spacecraft
<http://cluster.irap.omp.eu/>
- [5] Maoz, Dan. "Astrophysics in a Nutshell." Princeton University Press.2011. 5/17/16
- [6] Reme. "First multispacecraft ion measurements in and near the Earths magnetosphere with the identical Cluster ion spectrometry (CIS) experiment." July 2001. 5/17/16.
- [7] <http://www.qrg.northwestern.edu/projects/vss/docs/space-environment/3-what-is-solar-wind.html>
- [8] Kistler. L.M, Mouikis.C.G, Genestreti.K.J " In-flight calibration of the Cluster/CODIF sensor." 2013. 5/17/16.
- [9] Eberhardt, Edward H. "Gain model for microchannel plates." Applied Optics 18.9 (1979): 1418-1423.