

University of New Hampshire  
University of New Hampshire Scholars' Repository

---

Honors Theses and Capstones

Student Scholarship

---

Spring 2012

# Estimating Connecticut Stream Temperatures Using Predictive Models

Erik Carlson

*University of New Hampshire - Main Campus*

Follow this and additional works at: <https://scholars.unh.edu/honors>

 Part of the [Civil and Environmental Engineering Commons](#)

---

## Recommended Citation

Carlson, Erik, "Estimating Connecticut Stream Temperatures Using Predictive Models" (2012). *Honors Theses and Capstones*. 36.  
<https://scholars.unh.edu/honors/36>

This Senior Honors Thesis is brought to you for free and open access by the Student Scholarship at University of New Hampshire Scholars' Repository. It has been accepted for inclusion in Honors Theses and Capstones by an authorized administrator of University of New Hampshire Scholars' Repository. For more information, please contact [nicole.hentz@unh.edu](mailto:nicole.hentz@unh.edu).

# **Estimating Connecticut Stream Temperatures Using Predictive Models**

**Erik B. Carlson**

University of New Hampshire, 33 Academic Way, Durham, New Hampshire 03824, USA

**Jennifer Jacobs**

University of New Hampshire, Gregg Hall Room 240, 35 Colovos Road, Durham, New Hampshire  
03824, USA

**Mike Beauchene**

Connecticut Bureau of Water Protection and Land Reuse, 79 Elm Street, Hartford, Connecticut 06006,  
USA

**Phil Ramsey**

University of New Hampshire, Kingsbury Hall N321A, 33 Academic Way, Durham, New Hampshire  
03824, USA

Abstract:

The Connecticut Department of Energy and Environmental Protection (CT DEEP) seeks to better classify their streams into thermal regimes (cold, cold transitional, warm transitional, and warm water). A prediction model was created based upon physical characteristics such that CT DEEP could classify streams into thermal regimes based upon the parameters described in Lyons et al. 2009 and compare them to their own classification system. Accurately classifying these thermal regimes determines the environmental protection provided to a stream as well as the potential for establishing fisheries. Misclassifications of thermal regimes could prove detrimental to the ecosystem and its inhabitants if, for instance, a cold stream were misclassified as a warm stream; such streams risk being inadequately protected against warming such as runoff from impervious surfaces, potentially making the stream uninhabitable for native species. It should be noted that different stream thermal regime classifications have different criteria for assessing their biological integrity and fundamental ecosystem health (Lyons et al. 2009).

In order to classify streams into thermal regimes, a regression model and a neural network were created as predictive models of stream temperature using watershed parameters as independent variables. The final regression model had lower predictive power compared to the neural network; however, it revealed a set of 5 robust parameters which were significant for all three Lyons parameters. Using the Lyons parameters, the results of the neural network, regression model, and the provided measured data were classified into thermal regimes and compared with CT DEEP's current classification system. Comparison showed good results amongst the data modeled with the Lyons parameters; however, the CT DEEP classification system was biased towards cold classifications with no streams classified as being warm. In order for these

classification methods to be comparable, CT DEEP will have to update their current classification model to account for anthropogenic influences. It is only with these amendments that the CT DEEP classification model will be comparable with the results provided in their paper as well as determining the validity of using the Lyons thermal region classifications for use in Connecticut streams.

Introduction:

The purpose of this project was to create a predictive model of Connecticut stream temperatures based upon physical parameters and then classify the streams into thermal regimes (cold, cold transitional, warm transitional and warm water). The Connecticut Department of Energy and Environmental Protection (CT DEEP) has been interested in classifying streams using Lyons et al. (2009) thermal regimes established for Michigan and Wisconsin (Table 1 taken from Lyons et al. (2009)). This classification system is depicted in Table 1: Lyons Thermal Regime Classifications. The thermal regime which is of particular concern is cool water streams, which is not recognized as a major management category despite that walleye and northern pike, both major game fish, are classified as cool water species. The misclassification of streams could also lead to missed opportunities to establish and expand fisheries, for example, trout can still survive in cool water streams, however; if a cool water stream is grouped with warm water streams, opportunities to expand trout fisheries may be overlooked (Ibid).

Class and Subclass	June – August Mean (°C)	July Mean (°C)	Maximum Daily Mean (°C)
Cold Water	< 17.0	< 17.5	< 20.7
Cool Water	17.0 – 20.5	17.5 – 21.0	20.7 – 24.6
Cold Transitional	17.0 – 18.7	17.5 – 19.5	20.7 – 22.6
Warm Transitional	18.7 – 20.5	19.5 – 21.0	22.6 – 24.6
Warm Water	> 20.5	> 21.0	> 24.6

CT DEEP is interested in how suitable this system is in classifying Connecticut streams compared to their current methods of classification. Accurately classifying streams into thermal regimes is important in recognizing what species of fish can survive in a given ecosystem. Certain fish species, such as the eastern brook trout, a cold water species, are intolerant of large

temperature variations, and are thus unable to tolerate warmer temperatures. Improper stream classifications can lead to streams which are inadequately protected against environmental pollutants such as heat fluxes.

Proper stream classification is also vital in the ability to accurately measure the health of a stream and its inhabiting species. Compared to other thermal regimes, cool water streams utilize their own bioassessment indices to assess their “biological integrity, and underlying ecosystem health (Lyons et al. 2009).” If misclassified, a stream could be held to an inadequate measure of its biological integrity, and thus proper care may not be given to ensuring the health of the stream and the species which inhabit the ecosystem. Mike Beauchene of CT DEEP suggested that it is better to use temperatures to determine stream thermal regimes instead of the presence of fish species. The reasoning is that while one fish species may be considered, say, a cold water species, that does determine that a species is incapable of living in streams outside of that thermal regime. While this is not true for all species, it is still of note because it demonstrates that species classification is not an accurate constant by which thermal regimes should be measured and determined.

Methods:

The first steps taken in creating the predictive models was determining and collecting the physical parameters which would be employed as independent variables for predicting stream temperature as the response. After reading articles which attempted to create predictive stream temperature models based upon physical parameters, proposed physical parameters were identified (Table 2). Information contained in this table served as a checklist of required data for the to-be-created predictive models.

<b>Table 2: Proposed Physical Parameters from Publications</b>	
<b>Referenced Publication</b>	<b>Independent Variables Used in Predictive Model</b>
<i>Summer Stream Water Temperature Models for Great Lakes Streams: New York</i> (McKenna et al. 2010)	Average Elevation Average Slope Downstream Strahler Stream Order Groundwater Holding/Transporting Bedrock Index of Regional Heat Budget Percent Agricultural Cover Percent Forest Cover Percent Open Water Percent Sand/Gravel
The Nature Conservancy: Eastern Brook Trout Joint Venture	Air Temperature Geology Gradient Stream Size
<i>Defining and Characterizing Coolwater Streams and Their Fish Assemblages in Michigan and Wisconsin, USA</i> (Lyons et al. 2009)	Air Temperature Catchment Size Geology Land Cover Stream Network Position
<i>Numerically Optimized Empirical Modeling of Highly Dynamic, Spatially Expansive, and Behaviorally Heterogeneous Hydrologic Systems- Part 2</i> (Stewart et al. 2006)	Area–Drainage Area Bedrock Depth–Depth to Bedrock (0–50 feet) Bedrock Depth–Depth to Bedrock (101–200 feet) Bedrock Depth–Depth to Bedrock (51–100 feet) Bedrock Type–Sandstone Darcy Value–Darcy Land Cover–Agriculture Land Cover–Forest Land Cover–Urban Land Cover–Wetland Stream Network–Downstream Link Stream Network–Gradient Surficial Deposit Texture–Fine Surficial Deposit Texture–Medium

Dr. Jennifer Jacobs provided a spreadsheet entitle “Stream Temp by Month” which contained monthly mean temperatures for 150 different streams (Figure 1). For each stream, a corresponding latitude and longitude was provided for the point at which temperature measurements were taken. Using the latitude and longitude of each temperature measurement,



the USGS web-based Geographic Information System (GIS) called StreamStats was used to delineate and acquire watershed characteristics. Watersheds were delineated using the “Watershed Delineation from a Point” command and the “Basin Characteristics” command was used to determine watershed characteristics such as: drainage area, average elevation, and percent stratified drift. The watersheds and their associated data acquired through the “Basin Characteristics” command were then converted to a shapefile and exported to ArcMap v10 for modeling and spatial analysis.

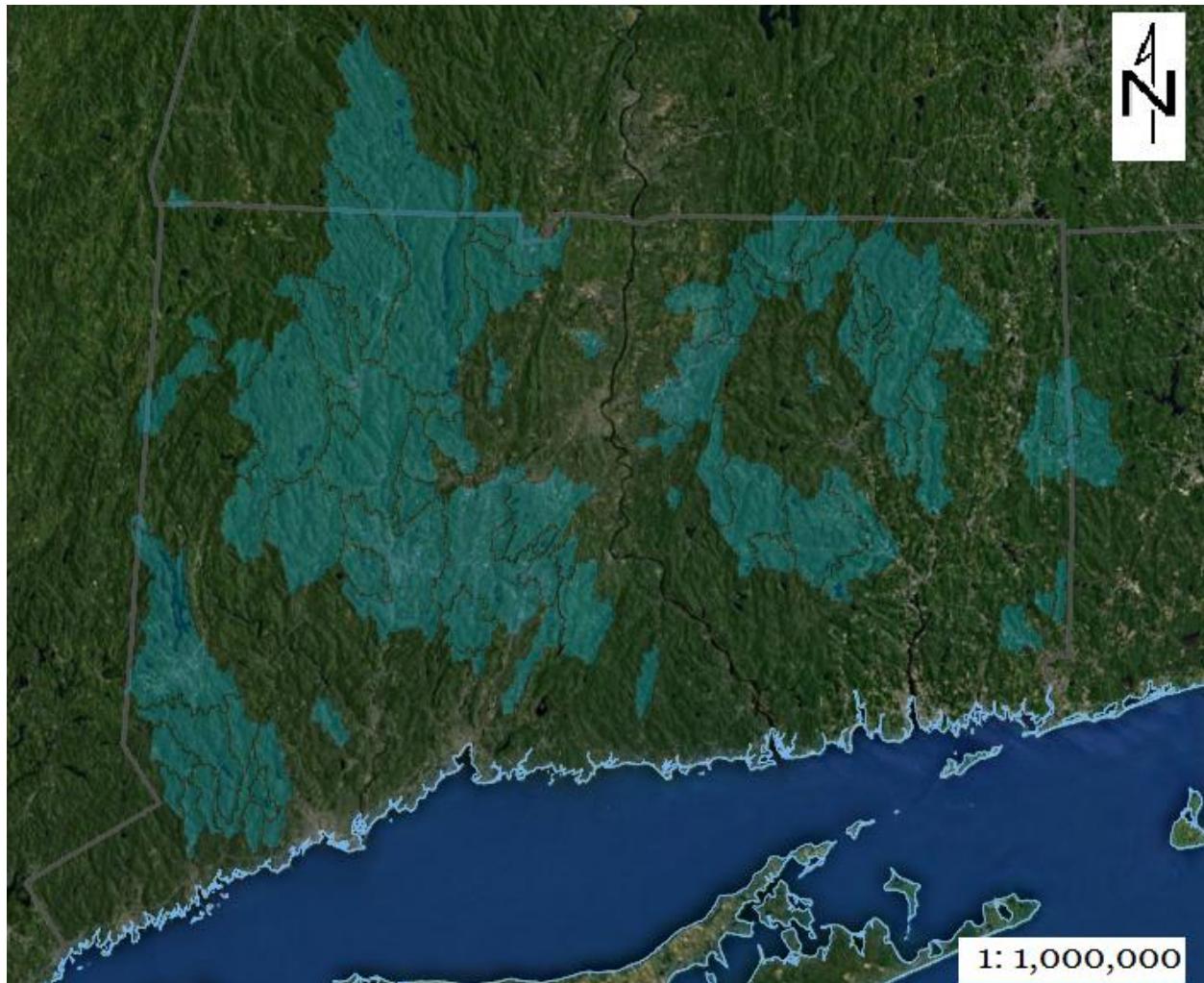

Figure 1: Watershed Basins

After compiling the parameters in Table 2 and conducting extensive searches for the datasets, it was determined that some parameters were unnecessary or unobtainable. Table 3 gives the revised list of parameters that was used in the predictive model creation. It should be noted that some of the data in Table 2 was determined to be redundant; for instance, “Downstream Strahler Stream Order” was determined to be representative of “Stream Size,” similarly, “Groundwater Holding/Transporting Bedrock” and “Darcy Value-Darcy” are synonymous with stratified drift, a parameter acquired from StreamStats. Other data, such as depth to bedrock, was determined to be unavailable after failed pursuits for the data. The unavailability of this data was later confirmed by David Bjerklie of USGS, and the parameter “Stream Network – Downstream Link” was determined to be insignificant in subsequent studies as indicated by Jana Stewart.

<b>Table 3: Revised Physical Parameters from Publications</b>	
<b>Referenced Publication</b>	<b>Independent Variables Used in Predictive Model</b>
<i>Summer Stream Water Temperature Models for Great Lakes Streams: New York</i> (McKenna et al. 2010)	Average Elevation Average Slope <del>Downstream Strahler Stream Order</del> <del>Groundwater holding/transporting bedrock</del> <del>Index of Regional Heat Budget</del> Percent Agricultural Cover Percent Forest Cover Percent Open Water Percent Sand/Gravel
The Nature Conservancy: Eastern Brook Trout Joint Venture	Air Temperature Geology Gradient Stream Size
<i>Defining and Characterizing Coolwater Streams and Their Fish Assemblages in Michigan and Wisconsin, USA</i> (Lyons et al. 2009)	Air Temperature Catchment Size Geology Land Cover <del>Stream Network Position</del>
<i>Numerically Optimized Empirical Modeling of Highly Dynamic, Spatially Expansive, and Behaviorally Heterogeneous Hydrologic Systems- Part 2</i> (Stewart et al. 2006)	Area–drainage area <del>Bedrock depth–Depth to Bedrock (0–50 feet)</del> <del>Bedrock depth–Depth to Bedrock (101–200 feet)</del> <del>Bedrock depth–Depth to Bedrock (51–100 feet)</del> <del>Bedrock Type–Sandstone</del> <del>Darcy value–Darcy</del> Land Cover–Agriculture Land Cover–Forest Land Cover–Urban Land Cover–Wetland <del>Stream Network–Downstream Link</del> Stream Network–Gradient Surficial Deposit Texture–Fine Surficial Deposit Texture–Medium

The final physical parameters used for predictive modeling are given in Table 4.

<b>Table 4: Final Parameters for Predictive Modeling</b>	
<b>Referenced Publication/ Individual</b>	<b>Independent Variables Used in Predictive Model</b>
<i>Summer Stream Water Temperature Models for Great Lakes Streams: New York</i> (McKenna et al. 2010)	Average Elevation Average Slope Percent Agricultural Cover Percent Forest Cover Percent Open Water Percent Sand/Gravel
The Nature Conservancy: Eastern Brook Trout Joint Venture	Air Temperature Geology Gradient Stream Size
<i>Defining and Characterizing Coolwater Streams and Their Fish Assemblages in Michigan and Wisconsin, USA</i> (Lyons et al. 2009)	Air Temperature Catchment Size Geology Land Cover
<i>Numerically Optimized Empirical Modeling of Highly Dynamic, Spatially Expansive, and Behaviorally Heterogeneous Hydrologic Systems- Part 2</i> (Stewart et al. 2006)	Area–drainage area Land Cover–Agriculture Land Cover–Forest Land Cover–Urban Land Cover–Wetland Stream Network–Gradient Surficial Deposit Texture–Fine Surficial Deposit Texture–Medium
Dr. Jennifer M. Jacobs	Dams

The inclusion of dams in the predictive model was a result of known shortcomings of the TNC temperature classification scheme as indicated by Michael Beauchene of CT DEEP. The TNC model was constructed solely on physical parameters such as stream size, air temperature, stream gradient, and groundwater influence, while disregarding the influence of human disturbances. As specified by Mr. Beauchene, the TNC model could be implemented for undeveloped, undisturbed areas; however, the model lacks the scope to be representative of larger areas in which human influences are present. This is the primary shortcoming of the model because Connecticut has undergone considerable landscape modifications since the era of the industrial

revolution. The results of these modifications are highly developed areas, increases in impervious surfaces, mass deforestation, and the construction of thousands of small dams.

After the acquisition of all the GIS data for the physical parameters specified in Table 4, each parameter was spatially analyzed using ArcMap v10 software. As depicted in Figure 1, spatial data from neighboring states were required due to the relative location of some of the delineated watershed basins to the Connecticut state line. The GIS data for all of the physical parameters were obtained from Connecticut, New York, Rhode Island, and Massachusetts state agencies and/or universities. Each physical parameter was clipped using the delineated watersheds, and were then linked with each watershed using the “Intersect” command in ArcMap. Each physical parameter was represented in one layer through the “Union” command to form complete spatial coverage over all the watersheds. It should be noted that for each watershed, the number of dams per watershed was determined and added to the corresponding attribute table in ArcMap. The dams were later represented as dams per square mile for statistical analysis. The complete data layers were then exported to JMP where they were statistically analyzed.

In preparing to analyze the data in JMP, it was noticed that some of the physical parameters had limited coverage, meaning that there existed some missing data measurements. It was determined that twelve watersheds did not have complete coverage for stream size and stream gradient, and after reviewing the GIS data, certain streams had not been mapped for the given watersheds. Later investigations confirmed that the initial stream sampling points were correct, and thus the resulting watershed delineations were correct as well. When statistically analyzing the data, these incomplete sets were removed from the model, thus resulting in a total of 138

watersheds with complete spatial coverage. The watersheds which had to be removed due to incomplete coverage were as follows (by Site ID): 223, 285, 717, 1081, 1225, 1226, 1228, 1243, 1697, 1735, 1748, and 2297.

Prior to analyzing the data, it was suggested by Dr. Jacobs to first simplify the data into more generalized categories for ease of interpretation. This proved useful in reducing the total number of physical parameters. The physical parameter of surficial materials was simplified to the following categories: alluvial deposits, artificial fill, fines, fluvial deposits, gravel, human transported material, loess, organic deposits, sand, swamp, till, and water. The physical parameter of land cover was simplified to the following categories: wetlands, water, forest, agriculture, residential, and developed. All data were expressed in terms of percent per watershed. To illustrate this, take a watershed of 10 square miles, and say that 1 square mile was till. The physical parameter, % Till, would be equal to 10% in the data table.

Before statistical analysis began, Mr. Beauchene provided a spreadsheet entitled “Real World Temperature Classifications” which listed streams by station ID and provided corresponding latitude and longitude of the points where temperature measurements were made. This file contained 539 unique streams and their corresponding Lyons thermal regime classification as compared to the thermal regime classification currently used by The Nature Conservancy (TNC). These TNC classifications were exported to the watershed data table in JMP and were used for comparison of the classification results of the prediction models and measured data using the Lyons parameters.

Results:

A regression analysis was first conducted on the entire data set in which a stepwise procedure was followed using P-value threshold as a stopping rule to determine which physical parameters were determined to be significant. The default settings were used for the P-value threshold and were “Prob to Enter” equal to 0.25, and “Prob to Leave” equal to 0.1. After the significant physical parameters were identified, a standard least squares regression model was created using those parameters. A check was conducted to ensure that only significant variables had been selected by observing that their corresponding  $\text{Prob} > |t|$  and VIF were less than 0.05 and 10.0 respectively.

The definition of VIF and the justification for the selected cutoff is defined in Helsel and Hirsch as follows:

“An excellent diagnostic for measuring multi-collinearity is the variance inflation factor (VIF) presented by Marquardt (1970). For variable  $j$  the VIF is:

$$\text{VIF}_j = \frac{1}{1 - R_j^2}$$

Where  $R_j^2$  is  $R^2$  from a regression of the  $j$ th explanatory variable on all of the other explanatory variables -- the equation used for adjustment of  $x_j$  in partial plots. The ideal is  $\text{VIF}_j \cong 1$ , corresponding to  $R_j^2 \cong 0$ . Serious problems are indicated when  $\text{VIF}_j > 10$  ( $R_j^2 > 0.9$ ). A useful interpretation of VIF is that multi-collinearity "inflates" the width of the confidence interval for the  $j$ th regression coefficient by the amount  $\text{VIF}_j$  compared to what it would be with a perfectly independent set of explanatory variables (Helsel and Hirsch, 1992).”

After the creation of the regression models for each of the three Lyons parameters, a regression line was fit to the data to determine the regression formula. This process was repeated for all Lyons parameters.

Prior to the creation of the neural network, it was suggested by Dr. Phillip Ramsey that the physical parameters be run through JMP's multivariate analysis to identify any correlation between the independent variables. Independent variables which had correlation values close or equal to -1.00 or 1.00 are considered to be equal, meaning that they represent the same phenomenon. All physical parameters that had correlations of 0.75 or higher were removed per recommendation of Stewart et al. (2006). As suggested by Dr. Ramsey, the multivariate platform was run in JMP to try and reduce the number of correlated independent variables fed into the neural network. Although the neural network has the ability to account for highly correlated input parameters, and has the ability to derive highly complex relationships, simplifications were desirable to attempt to gain a better understanding of the underlying relationship between the physical parameters and stream temperature.

The created neural network followed the K-Fold cross-validation technique based upon the small dataset size (less than approximately 1,000 observations). K-Fold cross validation is a method in which data is randomly partitioned into K subsets. Each of the K subsets is used to validate the model fit on the rest of the data, thus fitting a total of K models. The model which gives the best validation is used as the final model (Ramsey, 2011). A typical range of K values is from 5 to 20, with 10 being a common selection (Ibid.). For the purposes of this neural network K value of



10 was chosen. A single hidden layer with 34 neurons was selected for the neural network. The number of neurons was selected based upon Equation 1 in McKenna (2010):

$$N_H = \frac{1}{2}(N_I + N_O) + \sqrt{D_T} \quad (1)$$

where  $N_H$  is the number of neurons in the hidden layer,  $N_I$  is the number of input neurons,  $N_O$  is the number of output neurons, and  $D_T$  is the number of observations in the training data set. For the purposes of the neural network,  $N_I = 44$ ,  $N_O = 1$ , and  $D_T = 138$ , thus resulting in a  $N_H \approx 34$ .

After reviewing the data, Dr. Jacobs identified a conceptual model consisting of five parameters (Table 5) and tested their significance against one of the Lyons parameters in a regression analysis. This regression provided good results and then the same five parameters were tested against the remaining two Lyons parameters. These parameters were found to be significant across all three Lyons parameters, thus indicating that these five parameters were robust and thus indicating a fundamental relationship with stream temperature. Despite the lower predictive power (low to mid-0.40s), the consistent set of five parameters is in accordance with how scientists attempt to utilize a consistent set of physical parameters to explain streamflow values. Higher prediction results are expected if a non-linear regression analysis were performed on the data. This is because it is believed that the relationship between the physical parameters and stream temperature cannot be explained by a simple linear regression model, and that a more complex, non-linear relationship exists between the independent and response variables.

The benefit of using a regression model is that a relationship between input variables and the response is easily identified by the regression equation that is fit for the model. A regression analysis provides easy to interpret relationships between variables, and Table 5 was created from

the regression equations (shown in Figure 3) for the Lyons parameters where a ‘+’ indicates a positive correlation, and a ‘-’ indicates a negative correlation between the input and response variables. For example, it is intuitive that the more tree cover found onsite (% Forest), the more shade one would expect which would block sunlight, and thus reduce the temperature of the stream.

**Table 5: Significant Independent Variables for Regression Analysis**

<b>Measured Parameters</b>	Drainage Area	Stratified Drift	% per WS, Creek: >=3.861<38.61 sq.mi., Very Low Gradient: <0.02%	% per WS, Headwater: 0<3.861 sq.mi., High Gradient: >=2 < 5%	% per WS, Medium Tributary River >=200<1000 sq.mi., High Gradient: >=2 < 5%	% Forest
Maximum Daily Mean	+ 0.0323	- 0.0535	+ 0.1850	- 0.01954	- 173.8	- 0.0364
Jun-Aug Mean	+ 0.0216	- 0.0355	+ 0.1430	- 0.0204	- 125.5	- 0.0252
July	+ 0.0215	- 0.0394	+ 0.1403	- 0.0261	- 132.4	- 0.0288

While the neural network showed considerably better predictive power compared to the regression model results, one should cautious before taking these results at face value. These models inherently have too many parameters and over-fitting is a chronic issue with the neural network model (Ramsey, 2011). Neural networks also have the tendency to be unstable, meaning that their results can vary greatly based upon the dataset which is used to train and validate the models.

The following are critiques and criticisms of the implementation of neural networks for predictive modeling by Dr. Ramsey (Ramsey, 2011):

- “Many neural network developers knew nothing of statistics or statistical modeling. This often results in naïve, time-wasting rediscovery of old statistical methods like nonlinear

regression and a dizzying array of arcane and confusing terminology... Although neural networks have enjoyed great popularity among non-statisticians, their efficacy as a modeling strategy is not uniformly agreed upon by professional statisticians.”

- “Models suffer from chronic overfitting and a lack of interpretability, thus they are truly a black box modeling strategy.”
- “Some advantage may be gained in modeling complex systems with many inputs and this is probably their greatest strength.”
- “Neural nets are computationally intense and it may take a long time to converge for a large problem, if convergence occurs.”

In a neural network, each input is assigned a positive or negative coefficient, or weight ( ‘w’ as indicated in Figure 3a), when the model is first created. The most common type of neural network has three layers: an input layer, an output layer, and one “hidden” layer where data processing occurs. Each node within the hidden layer has an activation function associated with it which transforms the inputs into a signal, whereas each hidden node is modeled using the sigmoid function, a special type of logistic function, which is often used to model complex, nonlinear relationships (Figure 2).

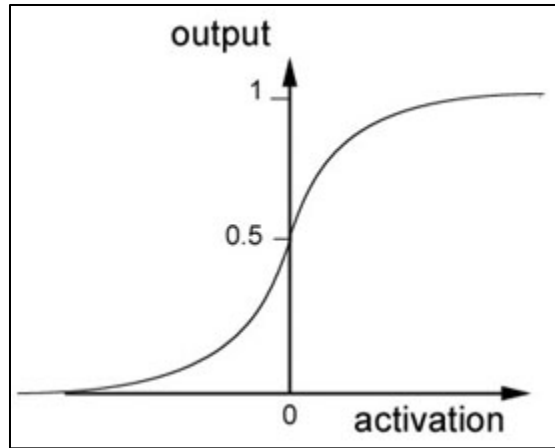

Figure 2: Sigmoid Function (Ramsey, 2011)

JMP version 9 uses the hyperbolic tangent function instead of the logistic function, due to its more flexible nature. The use of the  $\tanh()$  function allows the neural network model to approximate highly nonlinear and complicated relationships between inputs and outputs. Using these hyperbolic tangent functions, the outputs of the hidden nodes are turned into predictions, through the utilization of standard nonlinear least squares regression methods for each node. Figure 3 provides a pictorial representation of neural networks

Figure 3a & 3b (Ramsey, 2011)

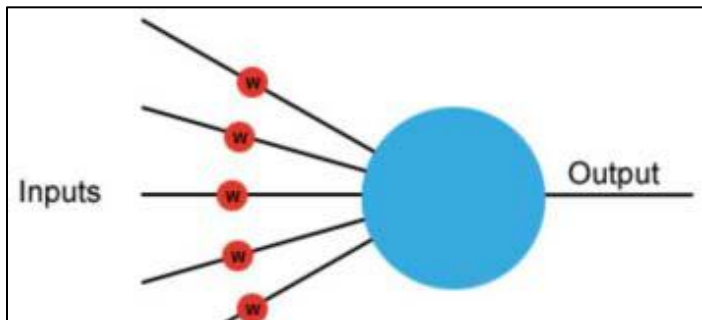

Figure 3a: Node

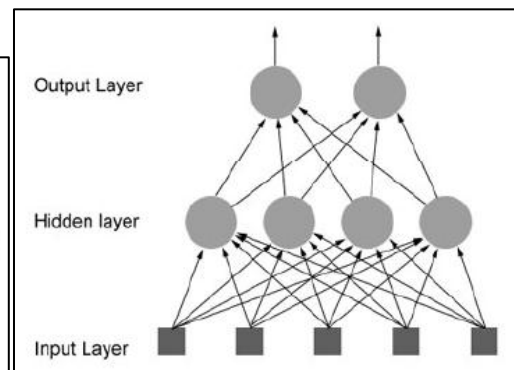

Figure 3b: Complete Neural Network

Tables 6 through 8 summarize the results of the regression analysis. For JMP output, refer to Appendix A.

<b>Table 6: Regression Results: June - August Mean</b>	
<b>Summary of Fit</b>	
R <sup>2</sup>	0.440
RMSE	1.357
N	138
<b>Parameter Estimates</b>	
Drainage Area	< 0.0001
Stratified Drift	0.0006
% per WS, Creek: >=3.861<38.61 sq.mi., Very Low Gradient: <0.02%	< 0.0001
% per WS, Headwater: 0<3.861 sq.mi., High Gradient: >=2 < 5%	0.0002
% per WS, Medium Tributary River >=200<1000 sq.mi., High Gradient: >=2 < 5%	< 0.0001
% Forest	0.0052

<b>Table 7: Regression Results: July Mean</b>	
<b>Summary of Fit</b>	
R <sup>2</sup>	0.401
RMSE	1.568
N	138
<b>Parameter Estimates</b>	
Drainage Area	< 0.0001
Stratified Drift	0.0009
% per WS, Creek: >=3.861<38.61 sq.mi., Very Low Gradient: <0.02%	< 0.0001
% per WS, Headwater: 0<3.861 sq.mi., High Gradient: >=2 < 5%	< 0.0001
% per WS, Medium Tributary River >=200<1000 sq.mi., High Gradient: >=2 < 5%	< 0.0001
% Forest	0.0057

<b>Table 8: Regression Results: Maximum Daily Mean</b>	
<b>Summary of Fit</b>	
R <sup>2</sup>	0.472
RMSE	1.715
N	138
<b>Parameter Estimates</b>	
Drainage Area	<b>P-Value</b> < 0.0001
Stratified Drift	< 0.0001
% per WS, Creek: >=3.861<38.61 sq.mi., Very Low Gradient: <0.02%	< 0.0001
% per WS, Headwater: 0<3.861 sq.mi., High Gradient: >=2 < 5%	0.0049
% per WS, Medium Tributary River >=200<1000 sq.mi., High Gradient: >=2 < 5%	< 0.0001
% Forest	0.0015

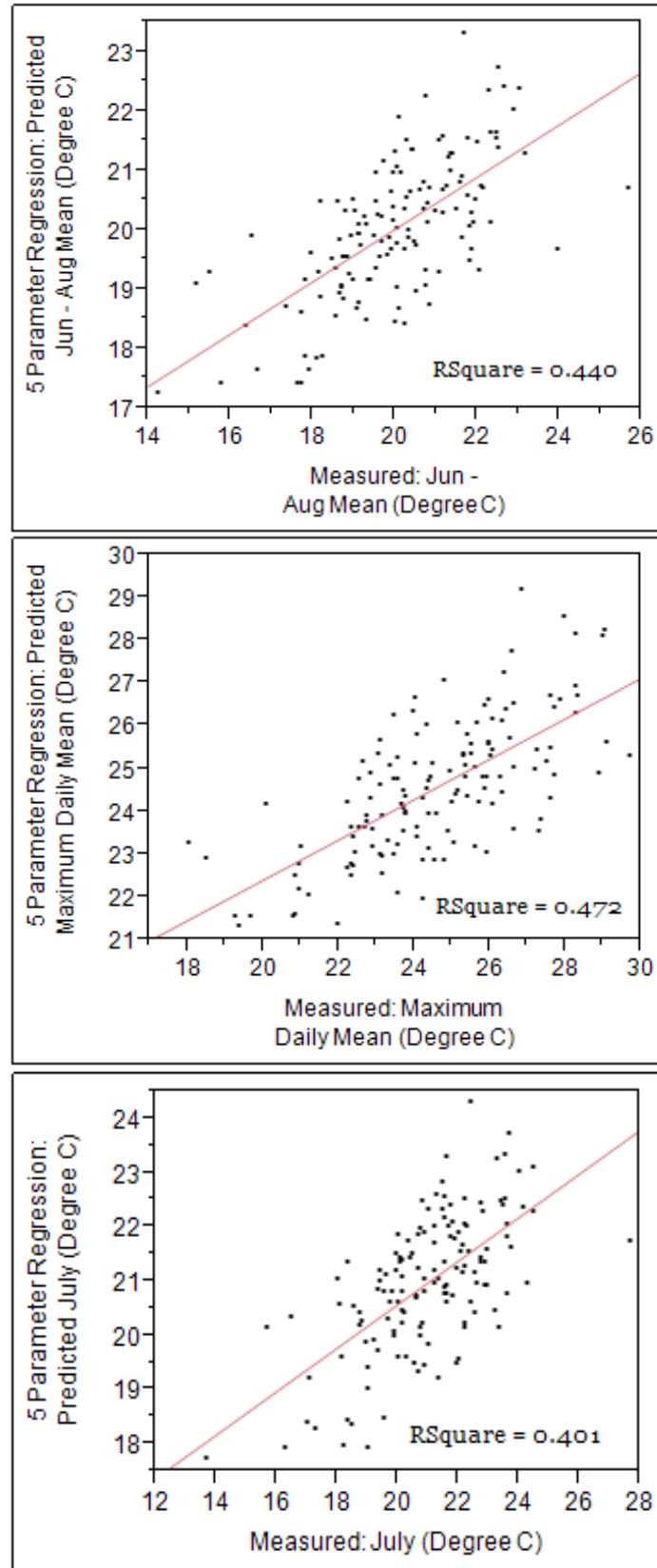

Figure 4: Regression Results of Lyons Parameters- Predicted vs. Measured

Tables 9 through 11 summarize the results of the neural networks. For JMP output, refer to Appendix A. The N value for the Training data represents the K subset which was used to train the model, and the N value for the Validation data represents the remaining data used to validate the models.

<b>Table 9: Neural Network Results: June - August Mean</b>	
<b>Training</b>	
R <sup>2</sup>	0.977
RMSE	0.278
N	14
<b>Validation</b>	
R <sup>2</sup>	0.937
RMSE	0.271
N	124

<b>Table 10: Neural Network Results: July Mean</b>	
<b>Training</b>	
R <sup>2</sup>	0.981
RMSE	0.281
N	14
<b>Validation</b>	
R <sup>2</sup>	0.986
RMSE	0.1412
N	124

<b>Table 11: Neural Network Results: Maximum Daily Mean</b>	
<b>Training</b>	
R <sup>2</sup>	0.986
RMSE	0.280
N	14
<b>Validation</b>	
R <sup>2</sup>	0.945
RMSE	0.407
N	124



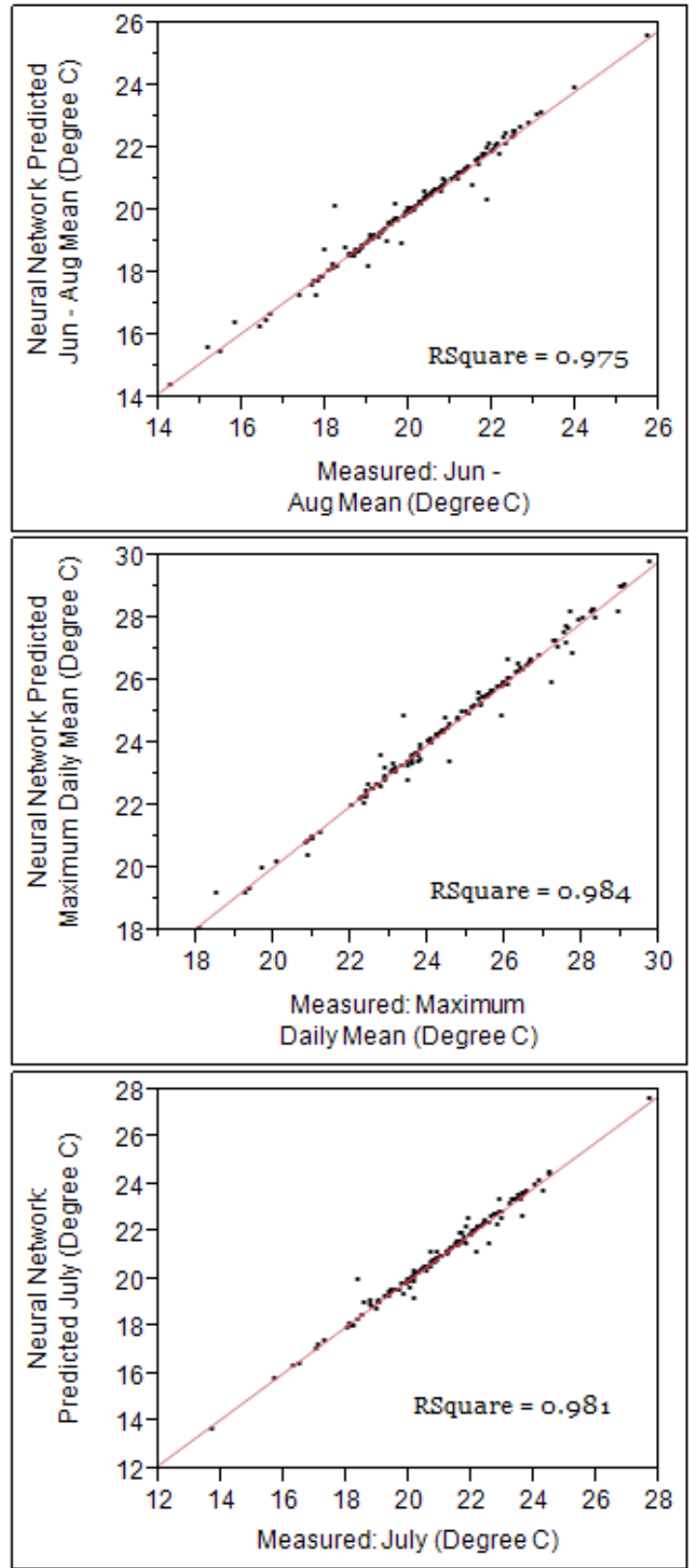

Figure 5: Neural Network Results of Lyons Parameters- Predicted vs. Measured

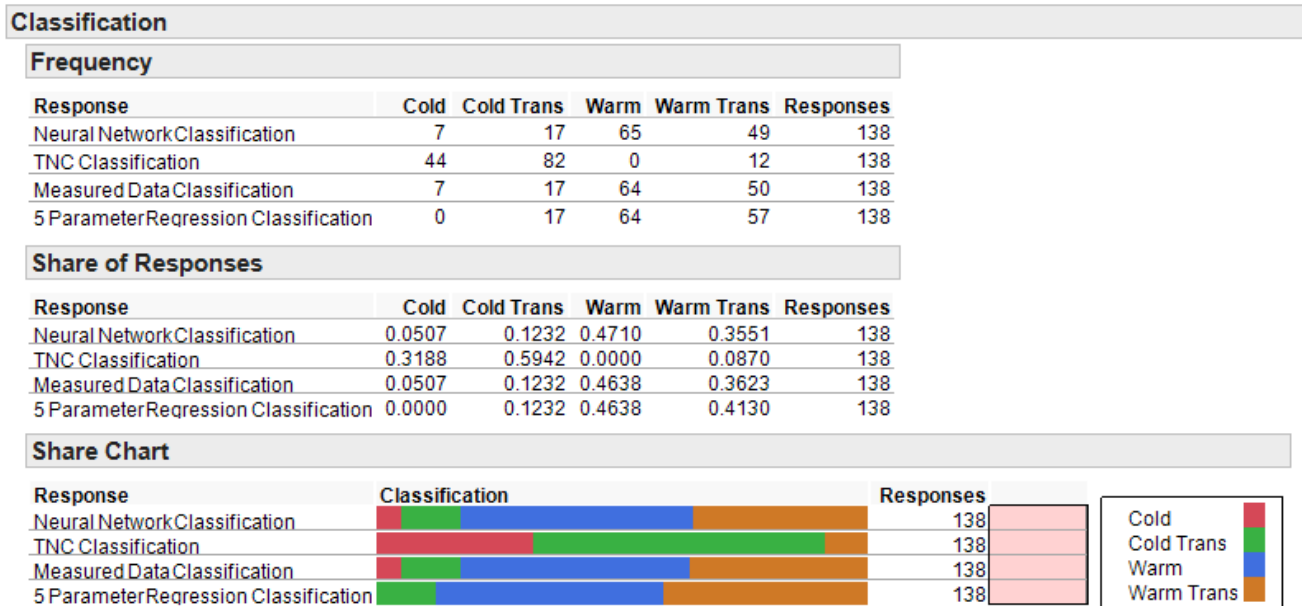

Figure 6: Classification Results and Comparisons

Classifications were conducted using the Lyons criteria for the results of the regression analysis, the neural network model, and for the provided measured data. These three were then compared to TNC classifications for the same set of streams. The thermal regime classifications and comparisons can be found above it Figure 6. It should be noted that a “2 of 3” rule was implemented in classifying streams with the Lyons parameters, meaning that if two of the three thresholds were satisfied, then the stream was designated as that thermal regime. Results from the neural network were nearly identical to that of the measured data. These results were expected due to the high predictive power found in the results of the Lyons parameters (See Appendix A). The regression model also performed well in classifying the thermal regimes with the exception of missing all cold water classifications. The TNC classification system for the analyzed streams has a bias towards cold water streams, a low number of sites being labeled as warm transitional, and no streams being classified as warm water. While the neural network is

unstable and tends to over-estimate models, it is reassuring to see that the regression analysis was also doing an adequate job at classifying Lyons thermal regimes.

Conclusion:

The TNC classification system does not consider human disturbances such as dams and impervious cover. Thus it provides likely regimes using physical parameters when the exclusion of anthropogenic influences is desired. However, these influences should be accurately accounted for, followed by a reclassification of the streams. Dams will also have to be reassessed in regards to how they are modeled in the regression analysis because they currently are considered statistically insignificant. Due to Connecticut's history of industrialization and large quantity of dams, the current measure of dams per square mile is inadequate and must be refined. According to A. Oliverio (2012 personal communication), "a better measure of the influence of dams on receiving streams is to measure the surface area of the water behind the dam." This water is stagnant and is thus more susceptible to the influences of solar heat fluxes than moving waterbodies. Accurately accounting for dams, withdrawals, and impervious surfaces in the TNC classification system would modify the current model to include anthropogenic influences. It is only after that these modifications are accomplished that a meaningful comparison of the Lyons thermal regime classifications and TNC classifications can be accomplished.

When reassessing the models and the parameters, care should be taken in ensuring the data utilized in the models is accurate and applicable for its intended use. In speaking with Dr. Ramsey about the possibility of highly correlated physical parameters, he mentioned that the methodology in modeling the stream size and stream gradient was flawed. Instead of having two separate measures for these parameters, they were grouped together as one variable to describe a given section of a stream. As an example, given a stream, a given length would be analyzed, and

for that given length, the size of the stream would be classified and then the gradient of that same section would be classified. It is recommended for future studies that these variables be separated to better model and understand their relationships with stream temperature.

Poor results of the regression models indicate that either the parameters measured were poor linear independent variables for temperature predictions or that a more complicated relationship exists which was not fully realized due to the exclusion of some unbeknownst data set(s). Despite these shortcomings, important relationships can be established still be established between stream temperature and the physical parameters. The set of five consistent significant physical parameters provides a basic relationship and understanding of the input and output relationship; however, it fails to describe the entire relationship, as is evident by the predictive power ( $R^2$ ) of the three Lyons parameters. To fully realize these relationships, a new, nonlinear regression model should be fit to all the physical parameters, and thus gain a better understanding of the relationship between the data. More data should also be included in the model in an attempt to account for any significant physical parameters which may have been omitted from the original model. Determining these other significant parameters could be a matter of testing additional parameters for significance in a prediction model. Running a nonlinear regression model on the original data will determine if additional physical parameters are need based upon the predictive power ( $R^2$ ) of the nonlinear regression model as well as if any newly significant physical parameters are present which may have neglected in the linear regression models. A nonlinear regression model would yield lower RMSE values compared to the current models, where the lower the RMSE, the smaller the difference between the actual and the predicted vales, and thus the more accurate the model.

While neural networks have been common practice in stream temperature prediction models, they act as a “black box” and are thus difficult to interpret. Neural networks also have a tendency to overestimate the relationship between data, and are usually unstable. This instability is the result of the ease in which the model can be altered and thus deemed unsuitable for predicting data based upon the data training set used to create, and later validate, the relationships between data. Unlike the regression model, the neural network provides little to no insight as to how variables relate to each other. Depending on the intended application of the predictive model, this may be undesirable if a clear relationship between the input and response variables is needed.

Whether a regression model or a neural network is utilized, the user will have to decide which better suits their needs. A neural network may be necessary to understand highly complex, nonlinear relationships; however, the user must be aware of the inherent limitations of the model and must be cautious before accepting the results at face value. While neural networks can provide desirable results and analyze and determine the relationship between highly correlated variables and complex relationships, they should be used only if one truly understands their underlying theory. The user should be aware of their potential shortcomings and the methods required to mitigate these shortcomings through validation of the created models. In comparison with the neural network, the regression model provides a clear picture of the relationship between independent and response variables. In determining which of the two model types to use, one should decide which is more desirable for the applications of the study: predictive power or parameter significance.

It is recommended that for future work with predictive models that the regression model be updated and the neural networks established for this study be validated with independent datasets. The regression model should be recreated using all physical variables again, with the exception that a nonlinear regression analysis be conducted. From the results of the regression model it is expected that a nonlinear relationship was present amongst the data, and thus conducting a nonlinear regression analysis should lead better results. Validation of the neural network should be conducted by applying an independent dataset to determine the stability of the models. Stability will be determined by how well the created models predict values with the independent dataset which was not a part of the creation of the neural networks. One of the most important characteristics which will have to be accounted for is warming due to anthropogenic influences. During the creation of the regression model, the influence of dams was found to be insignificant. It is hypothesized that dams would have a significant influence on stream temperature and therefore it would be advantageous to appropriately measure their influence in future models.

Acknowledgements:

Special thanks to: Dr. J. Jacobs, University of New Hampshire, M. Beauchene, Connecticut Department of Energy and Environmental Protection, Dr. P. Ramsey, University of New Hampshire, Dr. J. Lyons, Wisconsin Department of Natural Resources, A. Olivero, The Nature Conservancy, and J. Stewart, USGS. It was their help and insight which helped make this project possible.



References:

- “2006 Statewide Land Cover” [map]. 1:125,000. Connecticut Department of Energy & Environmental Protection GIS Data [computer files]. Hartford, Connecticut: 2009. ArcCatalog [GIS software]. Version 9.3. Redlands, California: Esri, 2008.
- “Connecticut Dams” [map]. 1:24,000. Connecticut Department of Energy & Environmental Protection GIS Data [computer files]. Hartford, Connecticut: 1996. ArcInfo [GIS software]. Version 7. Redlands, California: Esri, 1995.
- “Connecticut Place Names” [map]. 1:24,000. Connecticut Department of Energy & Environmental Protection GIS Data [computer files]. Hartford, Connecticut: 2006. ArcInfo [GIS software]. Version 7. Redlands, California: Esri, 1995.
- “Connecticut Surficial Materials” [map]. 1:24,000. Connecticut Department of Energy & Environmental Protection GIS Data [computer files]. Hartford, Connecticut: 1994. ArcCatalog [GIS software]. Version 9.3. Redlands, California: Esri, 2008.
- “Connecticut Base Map” [map]. 1:24,000 – 1:125,000. Connecticut Department of Energy & Environmental Protection GIS Data [computer files]. Hartford, Connecticut: 1984-2008.
- Cunningham, P., Carney, J., & Jacob, S. (2000). Stability Problems with Artificial Neural Networks and the Ensemble Solution. *Artificial Intelligence in Medicine*, 1-9.
- “Dams” [map]. Massachusetts Office of Geographic Information (MassGIS) [computer files]. Boston, Massachusetts: 2012.
- “Dams” [map]. New York State Department of Environmental Conservation [computer files]. Albany, New York: 2009. ArcCatalog [GIS software]. Version 9.3. Redlands, California: Esri, 2011.
- “Dams” [map]. Rhode Island Geographic Information System [computer files]. Kingston, Rhode Island: 2000.
- Helsel, D.R. and R.M. Hirsch. "Statistical Methods in Water Resources." Techniques of Water-Resources Investigations of the United States Geological Survey (1992): 305-306.
- “Land Cover/Land Use for Rhode Island 2003/04” [map]. 1:5,000. Rhode Island Geographic Information System [computer files]. Kingston, Rhode Island: 2007. ArcCatalog [GIS software]. Version 9.2. Redlands, California: Esri, 2006.

“Land Use (2005)” [map]. Massachusetts Office of Geographic Information (MassGIS) [computer files]. Boston, Massachusetts: 2005.

Lyons, J., Zorn, T., Steward, J., Seelbach, P., Wehrly, K., & Wang, L. (2009). Defining and Characterizing Coolwater Streams and Their Fish Assemblages in Michigan and Wisconsin, USA. *North American Journal of Fisheries Management*, 1130-1148.

PRISM Climate Group. (2012, February). *PRISM Products Matrix*. Retrieved from PRISM Climate Group: <http://www.prism.oregonstate.edu/>

Ramsey, P. (2011). Neural Network Models for Classification and Prediction. *Advanced Statistical Methods for Research: Math 736/836*, 1-62.

“Soil Survey Geographic (SSURGO) Soil Polygons for the State of Rhode Island” [map]. Rhode Island Geographic Information System [computer files]. Kingston, Rhode Island: 2011.

Stewart, J., Mitro, M., Roehl Jr., E., & Risley, J. (2006). Numerically Optimized Empirical Modeling of Highly Dynamic, Spatially Expansive, and Behaviorally Heterogeneous Hydrologic Systems. *7th International Conference on Hydroinformatics*, 1-8.

“Surficial Geology (1:24,000)” [map]. 1:24,000. Massachusetts Office of Geographic Information (MassGIS) [computer files]. Boston, Massachusetts: 2011.

“Surficial Geology- Lower Hudson Sheet” [map]. 1:250,000. New York State Geological Survey [computer files]. Albany, New York: 1999.

Wehrly, K., Wiley, M., & Seelbach, P. (2003). Classifying Regional Variation in Thermal Regime Based on Stream Fish Community Patterns. *Transactions of the American Fisheries Society*, 18-35.

# Appendix A

## Statistical Analysis Results

5 Parameter Regression Analysis: Regression Results (Figure A1, A2, & A3)

Response Measured: Jun - Aug Mean (Degree C)					
<b>Summary of Fit</b>					
RSquare		0.440045			
RSquare Adj		0.414398			
Root Mean Square Error		1.356526			
Mean of Response		20.0197			
Observations (or Sum Wgts)		138			
<b>Analysis of Variance</b>					
Source	DF	Sum of Squares	Mean Square	F Ratio	
Model	6	189.44002	31.5733	17.1579	
Error	131	241.06149	1.8402	<b>Prob &gt; F</b>	
C. Total	137	430.50151		<.0001*	
<b>Parameter Estimates</b>					
Term	Estimate	Std Error	t Ratio	Prob> t	VIF
Intercept	21.635761	0.625932	34.57	<.0001*	.
DRNAREA	0.0215962	0.003433	6.29	<.0001*	1.7747216
CRSDFT	-0.035503	0.010069	-3.53	0.0006*	1.3042274
% per WS, Creek: >=3.861<38.61 sq.mi., Very Low Gradient: <0.02%	0.143014	0.029362	4.87	<.0001*	1.0311649
% per WS, Headwater: 0<3.861 sq.mi., High Gradient: >=2 < 5%	-0.02039	0.005395	-3.78	0.0002*	1.1510525
% per WS, Medium Tributary River >=200<1000 sq.mi., High Gradient: >=2 < 5%	-125.5203	26.52419	-4.73	<.0001*	1.7072132
% Forest	-0.025168	0.008846	-2.85	0.0052*	1.3493354
<b>Prediction Expression</b>					
21.6357612972077					
+ 0.02159616341119 *DRNAREA					
+ -0.0355030325278 *CRSDFT					
+ 0.14301399566071					
+ % per WS, Creek: >=3.861<38.61 sq.mi., Very Low Gradient: <0.02%					
+ -0.0203900487335					
+ % per WS, Headwater: 0<3.861 sq.mi., High Gradient: >=2 < 5%					
+ -125.52027929875					
+ % per WS, Medium Tributary River >=200<1000 sq.mi., High Gradient: >=2 < 5%					
+ -0.025168368921 *% Forest					

Figure A1: Regression Results: June – August Mean

**Response Measured: Maximum Daily Mean (Degree C)**

**Summary of Fit**

RSquare	0.472325
RSquare Adj	0.448156
Root Mean Square Error	1.715377
Mean of Response	24.54321
Observations (or Sum Wqts)	138

**Analysis of Variance**

Source	DF	Sum of Squares	Mean Square	F Ratio
Model	6	345.03577	57.5060	19.5431
Error	131	385.46974	2.9425	<b>Prob &gt; F</b>
C. Total	137	730.50551		<.0001*

**Parameter Estimates**

Term	Estimate	Std Error	t Ratio	Prob> t	VIF
Intercept	26.664747	0.791514	33.69	<.0001*	.
DRNAREA	0.0322974	0.004341	7.44	<.0001*	1.7747216
CRSDFT	-0.053483	0.012732	-4.20	<.0001*	1.3042274
% per WS, Creek: >=3.861<38.61 sq.mi., Very Low Gradient: <0.02%	0.1849817	0.03713	4.98	<.0001*	1.0311649
% per WS, Headwater: 0<3.861 sq.mi., High Gradient: >=2 < 5%	-0.01954	0.006822	-2.86	0.0049*	1.1510525
% per WS, Medium Tributary River >=200<1000 sq.mi., High Gradient: >=2 < 5%	-173.7539	33.54079	-5.18	<.0001*	1.7072132
% Forest	-0.036385	0.011186	-3.25	0.0015*	1.3493354

**Prediction Expression**

26.6647471186622  
 +0.03229738352489\*DRNAREA  
 +-0.0534832809489\*CRSDFT  
 +0.18498174656539  
 +\*% per WS, Creek: >=3.861<38.61 sq.mi., Very Low Gradient: <0.02%  
 -0.0195401920851  
 +\*% per WS, Headwater: 0<3.861 sq.mi., High Gradient: >=2 < 5%  
 -173.75393414381  
 + % per WS, Medium Tributary River >=200<1000 sq.mi., High Gradient:  
 +\* >=2 < 5%  
 +-0.0363845941273\*% Forest

Figure A2: Regression Results: Maximum Daily Mean

**Response Measured: July**

**Summary of Fit**

RSquare	0.40123
RSquare Adj	0.373806
Root Mean Square Error	1.567963
Mean of Response	20.96799
Observations (or Sum Wqts)	138

**Analysis of Variance**

Source	DF	Sum of Squares	Mean Square	F Ratio
Model	6	215.81260	35.9688	14.6303
Error	131	322.06443	2.4585	Prob > F
C. Total	137	537.87703		<.0001*

**Parameter Estimates**

Term	Estimate	Std Error	t Ratio	Prob> t	VIF
Intercept	23.032436	0.723493	31.84	<.0001*	.
DRNAREA	0.0214967	0.003968	5.42	<.0001*	1.7747216
CRSDFT	-0.039374	0.011638	-3.38	0.0009*	1.3042274
% per WS, Creek: >=3.861<38.61 sq.mi., Very Low Gradient: <0.02%	0.1402832	0.033939	4.13	<.0001*	1.0311649
% per WS, Headwater: 0<3.861 sq.mi., High Gradient: >=2 < 5%	-0.026051	0.006236	-4.18	<.0001*	1.1510525
% per WS, Medium Tributary River >=200<1000 sq.mi., High Gradient: >=2 < 5%	-132.445	30.6584	-4.32	<.0001*	1.7072132
% Forest	-0.028767	0.010225	-2.81	0.0057*	1.3493354

**Prediction Expression**

23.0324357145591  
 +0.02149670450144\*DRNAREA  
 +-0.0393742980517\*CRSDFT  
 0.14028322537346  
 +\*% per WS, Creek: >=3.861<38.61 sq.mi., Very Low Gradient: <0.02%  
 -0.0260508430425  
 +\*% per WS, Headwater: 0<3.861 sq.mi., High Gradient: >=2 < 5%  
 -132.44502725891  
 +\*% per WS, Medium Tributary River >=200<1000 sq.mi., High Gradient:  
 >=2 < 5%  
 +-0.028767259782\*% Forest

Figure A3: Regression Results: July Mean

5 Parameter Regression Analysis: Predicted vs. Measured (Figure A4, A5, & A6)

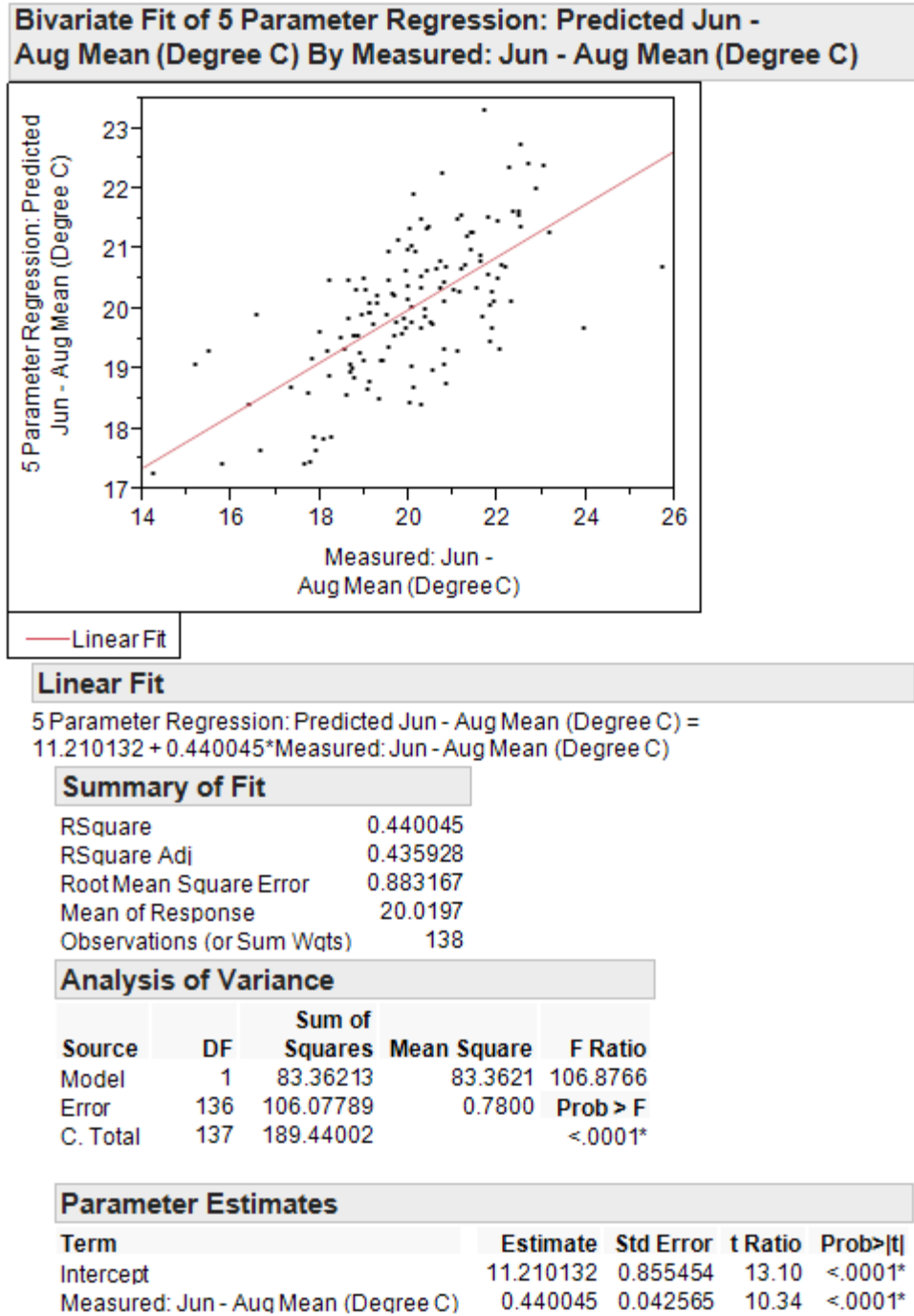

Figure A4: Regression Predicted vs. Measured: June – August Mean

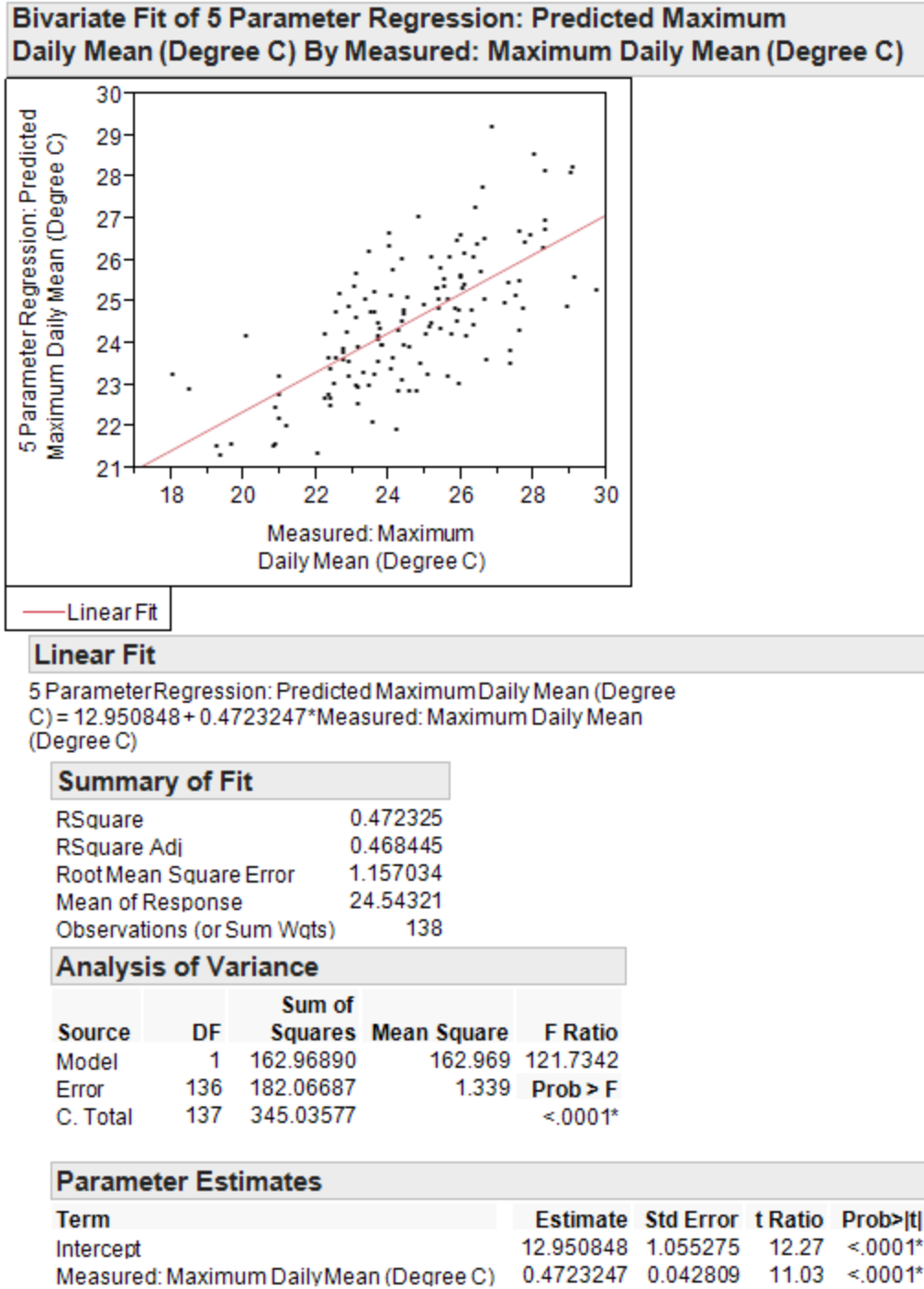

Figure A5: Regression Predicted vs. Measured: Maximum Daily Mean



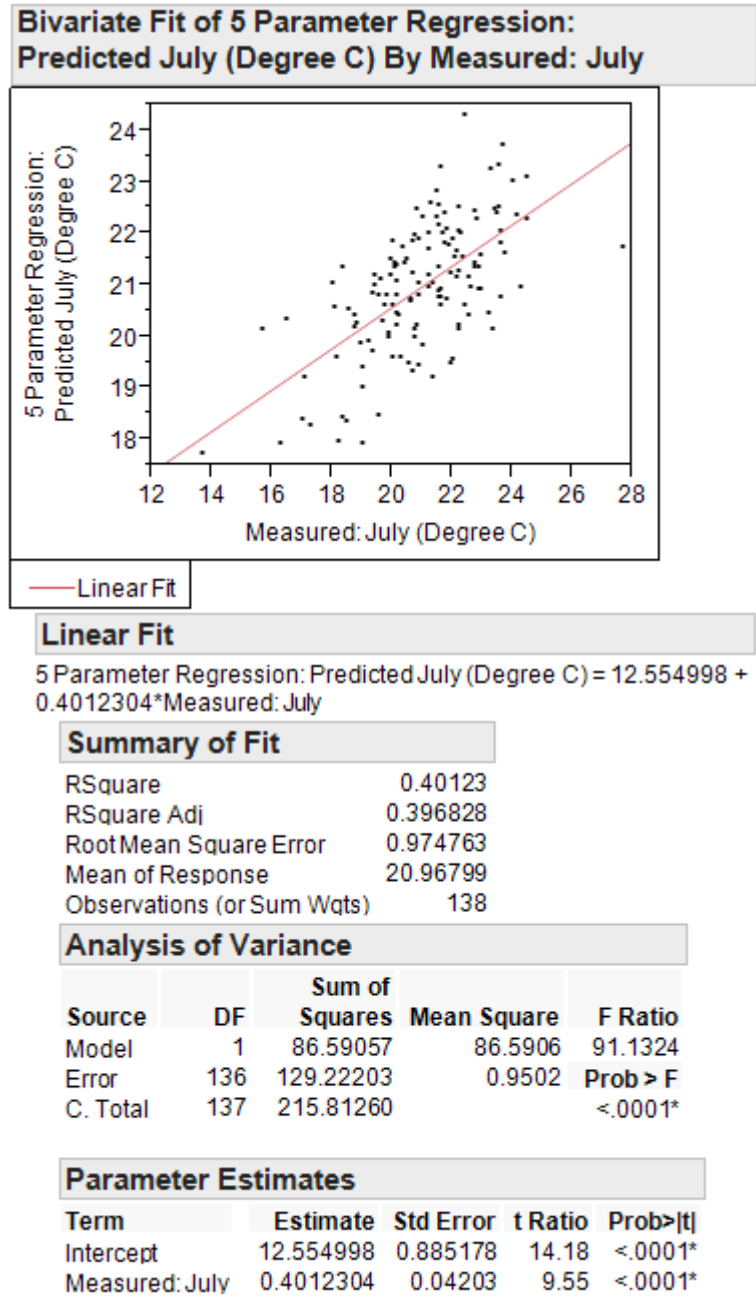

Figure A6: Regression Predicted vs. Measured: July Mean

Neural Network Analysis: Model Results (Figure A7, A8, & A9)

<b>Neural</b>			
Validation: Random KFold			
▶ <b>Model Launch</b>			
▶ <b>Model NTanH(34)</b>			
▶ <b>Training</b>		▶ <b>Validation</b>	
<b>Measured: Jul</b>	<b>Measures</b>	<b>Measured: Jul</b>	<b>Measures</b>
RSquare	0.980815	RSquare	0.9863645
RMSE	0.280921	RMSE	0.141241
Mean Abs Dev	0.1339869	Mean Abs Dev	0.0967358
-LogLikelihood	18.657081	-LogLikelihood	-6.998536
SSE	9.8645741	SSE	0.2593374
Sum Freq	125	Sum Freq	13

Figure A7: Neural Network Results: July Mean

<b>Neural</b>			
Validation: Random KFold			
▶ <b>Model Launch</b>			
▶ <b>Model NTanH(34)</b>			
▶ <b>Training</b>		▶ <b>Validation</b>	
<b>Jun -</b>		<b>Jun -</b>	
<b>Aug Mean</b>	<b>Measures</b>	<b>Aug Mean</b>	<b>Measures</b>
RSquare	0.9767603	RSquare	0.9369722
RMSE	0.2778977	RMSE	0.270682
Mean Abs Dev	0.1121433	Mean Abs Dev	0.1430413
-LogLikelihood	17.304557	-LogLikelihood	1.4576649
SSE	9.6533942	SSE	0.9524939
Sum Freq	125	Sum Freq	13

Figure A8: Neural Network Results: June - August Mean

<b>Neural</b>			
Validation: Random KFold			
▶ <b>Model Launch</b>			
▶ <b>Model NTanH(34)</b>			
▶ <b>Training</b>		▶ <b>Validation</b>	
<b>Max(Mean of value)</b>	<b>Measures</b>	<b>Max(Mean of value)</b>	<b>Measures</b>
RSquare	0.9857532	RSquare	0.9446362
RMSE	0.280156	RMSE	0.4072045
Mean Abs Dev	0.1393895	Mean Abs Dev	0.1980779
-LogLikelihood	18.31622	-LogLikelihood	6.7664847
SSE	9.8109214	SSE	2.1556018
Sum Freq	125	Sum Freq	13

Figure A9: Neural Network Results: Maximum Daily Mean

Neural Network Analysis: Predicted vs. Measured (Figure A10, A11, & A12)

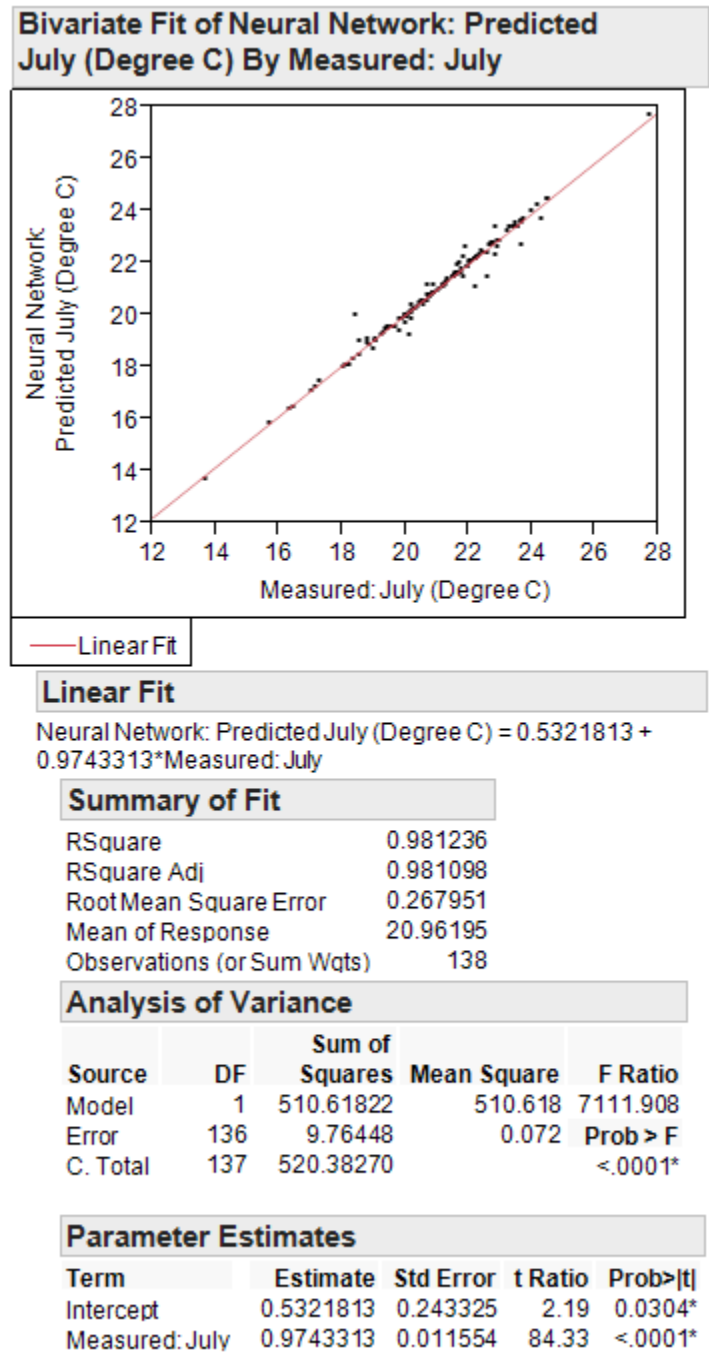
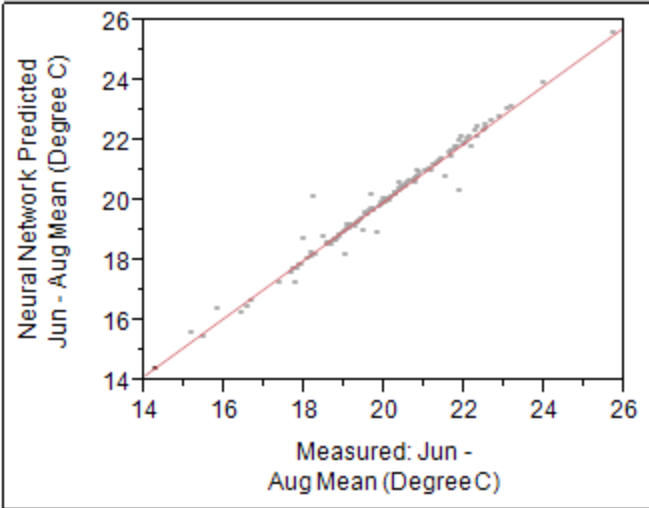

Figure A10: Neural Network Predicted vs. Measured: July Mean

**Bivariate Fit of Neural Network: Predicted Jun - Aug Mean (Degree C) By Measured: Jun - Aug Mean (Degree C)**



— Linear Fit

**Linear Fit**

Neural Network: Predicted Jun - Aug Mean (Degree C) =  
 $0.6152637 + 0.9689389 * \text{Measured: Jun - Aug Mean (Degree C)}$

**Summary of Fit**

RSquare	0.975421
RSquare Adj	0.97524
Root Mean Square Error	0.273654
Mean of Response	20.01313
Observations (or Sum Wqts)	138

**Analysis of Variance**

Source	DF	Sum of Squares	Mean Square	F Ratio
Model	1	404.17311	404.173	5397.132
Error	136	10.18458	0.075	Prob > F
C. Total	137	414.35769		<.0001*

**Parameter Estimates**

Term	Estimate	Std Error	t Ratio	Prob> t
Intercept	0.6152637	0.265067	2.32	0.0218*
Measured: Jun - Aug Mean (Degree C)	0.9689389	0.013189	73.47	<.0001*

Figure A11: Neural Network Predicted vs. Measured: June - August Mean

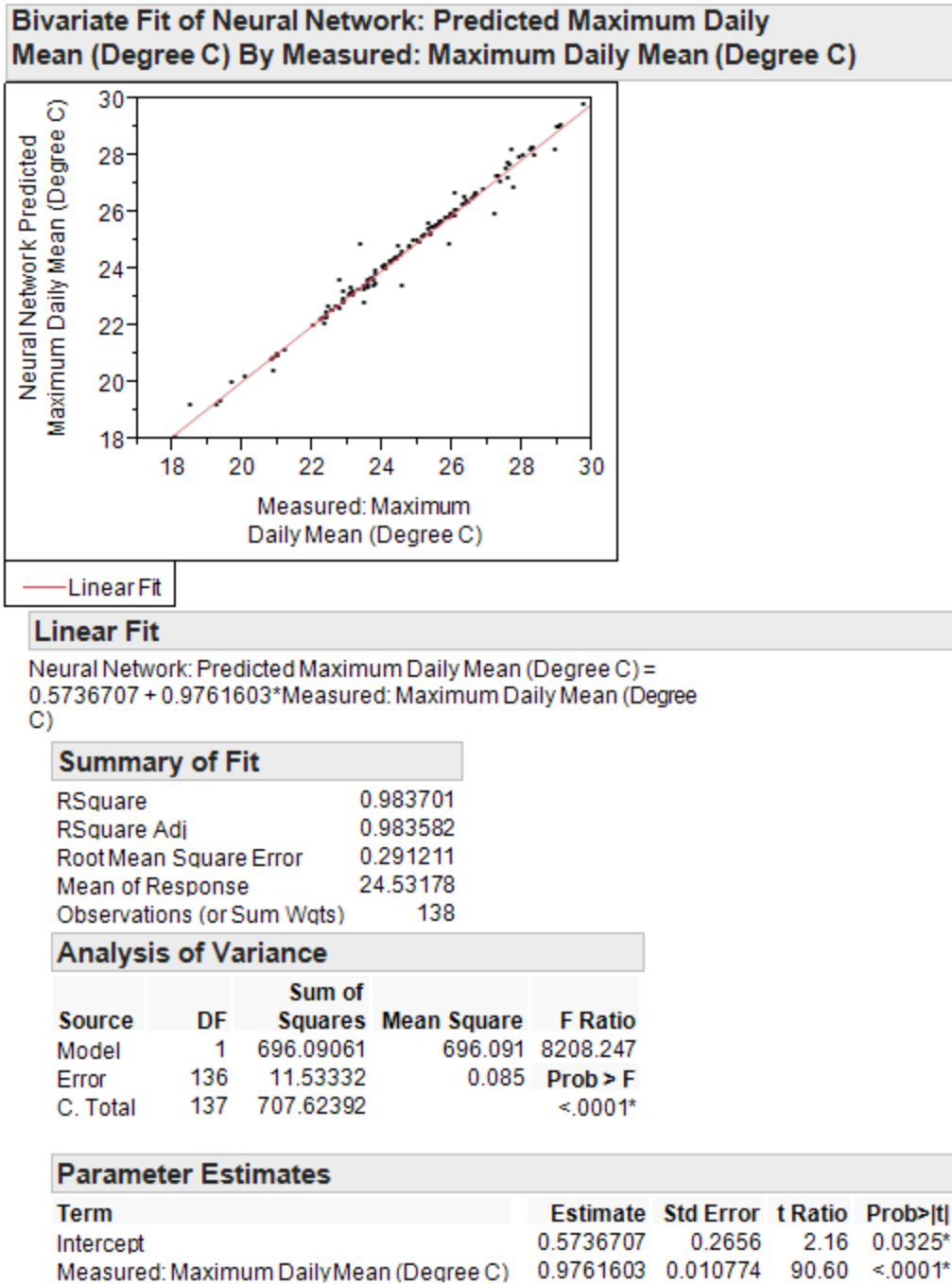

Figure A12: Neural Network Predicted vs. Measured: Maximum Daily Mean