



University of North Florida
UNF Digital Commons

All Volumes (2001-2008)

The Osprey Journal of Ideas and Inquiry

2006

Structural Vibrations Laboratory Demonstrator

Reen E. Foley
University of North Florida

Follow this and additional works at: http://digitalcommons.unf.edu/ojii_volumes

 Part of the [Engineering Commons](#)

Suggested Citation

Foley, Reen E., "Structural Vibrations Laboratory Demonstrator" (2006). *All Volumes (2001-2008)*. 135.
http://digitalcommons.unf.edu/ojii_volumes/135

This Article is brought to you for free and open access by the The Osprey Journal of Ideas and Inquiry at UNF Digital Commons. It has been accepted for inclusion in All Volumes (2001-2008) by an authorized administrator of UNF Digital Commons. For more information, please contact [Digital Projects](#).

© 2006 All Rights Reserved



Structural Vibrations Laboratory Demonstrator

Reen E. Foley

Faculty Advisor: Dr. Faris Malhas,
Professor of Engineering

1.0 Introduction

The primary objective of this project was to develop a laboratory demonstrator of structural vibrations. When the ground moves under a structure the effect on that structure is dependent upon the relationship between the frequency of the ground motion and the natural frequency of the structure. As this relationship, the frequency ratio, approaches one (1) the effect is at its most extreme. Mass, height, density of materials, modulus of elasticity, Poisson's Ratio, damping, and bracing are variables that dictate a structure's natural frequency. Comprehending the effects of these variables on a structure's natural frequency and subsequently the effects on have worked problems on paper and come up with numbers but do not have a conceptual understanding. This demonstrator illustrates those effects.

In the simplest of terms, this demonstrator simulates an earthquake. A two story structures of aluminum framing and plywood flooring has been built for demonstrations. The demonstrations can be useful to several classes: Static and Dynamics – two junior year courses required for all engineering disciplines; Mechanics of Materials – a required course for civil engineers; Structural Design and Structural Analysis – two

required courses for civil engineers. The initial demonstration was performed with an audience and video taped. The video is available through the Department of Engineering for viewing.

The project will become a permanent piece of equipment in the structural testing lab of the engineering department. It will be available for future demonstration. Additionally, it will be a tremendous stepping-stone for other student in the engineering department. For example, if a student or group of students wanted to do research on a new method for earthquake damage prevention for their senior project, it would be a valuable asset.

2.0 Equipment

2.1 Machine

To facilitate the demonstrations a means to create ground motion was researched. An electrical machine designed for that purpose proved the most practical. An older used machine was the most economical way to provide the desired frequency and displacement.

A Vibration Fatigue Testing Machine by All American Tool and Manufacturing Company was obtained. This machine provided a 15 inch by 18 inch table with a horizontal movement of total adjustable displacement between 0 inches and 0.150 inches. The table has a load capacity of 100 pounds at 10 g and a maximum capacity of 23 g. The frequency of the table can be set to vary between 10 and 60 cycles per second or it can be set to stay constant at any of those variables.

The dimensions of the machine are 13.5 inches high with a base of 26 inches by 48 inches. The total weight of the machine is 690 pounds. It has a 1.5 horsepower motor that runs on a 220 volt, 3 phase A.C

connection. A power plug and cord were installed on the machine to provide power from a distance. Figure 2.1 is a photograph of the Vibration Machine.



Figure 2.1 – Vibration Fatigue Testing Machine.

2.2 Foundation Design and Installation

In demonstrations it is important that the vibrations created by the machine are confined to the shaking table and not transmitted either to its base or its foundation. To ensure this, a resilient foundation of steel was designed to anchor the base of the machine to the permanent concrete floor of the structural testing laboratory. The floor of the lab is three feet

thick with anchored bolt holes for one and a half inch bolts.

The foundation was constructed from 4 L8X8X1 angles of 60 ksi steel, with side anchoring plates welded to the two side angles. Figure 2.2 illustrates the design of the foundation. The AutoCAD and drawings for the foundation can be viewed in Appendix A. Additionally; the members were painted to minimize rust and corrosion. Using a forklift, the vibration

machine was mounted onto the foundation and bolted in place.

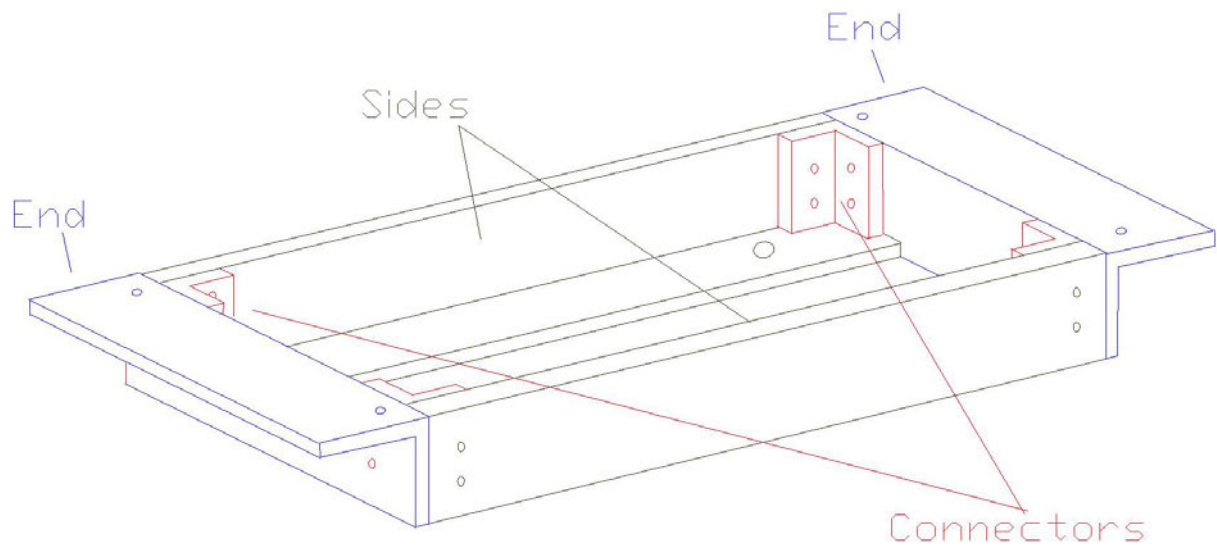

Figure 2.2 – Foundation Design.

3.0 Structure

3.1 Single Degree of Freedom

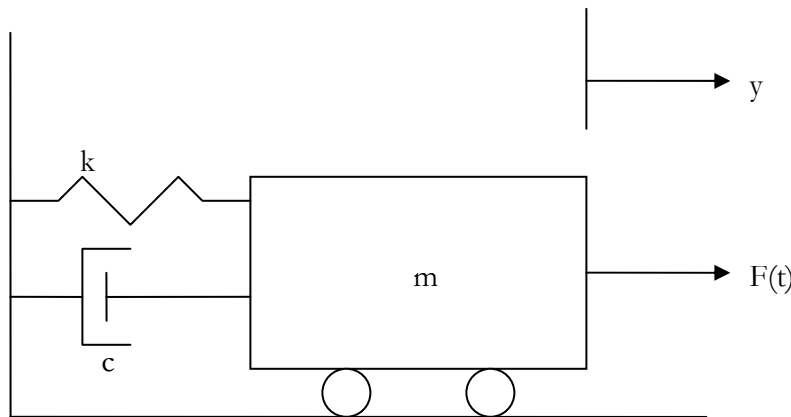

Figure 3.1 – Single-degree-of- Freedom system.

In mathematical modeling a structure is considered to have one degree of freedom. The damping element (c), and external force ($F(t)$). These elements are described in Figure 3.1. In the figure, y represents the displacement of the structure. Summing

the forces to the figure can be represented by the equation:

$$F(t) = ky + cy' + my'' \quad (1)$$

Independent variables:

$k =$ spring (constant)

$c =$ damping coefficient (constant)

$m = \text{mass (constant)}$

Dependent Variables

$y = \text{displacement (first derivative of displacement)}$

$y' = \text{velocity (second derivative of displacement)}$

$y'' = \text{acceleration}$

In a single degree of freedom with no damping, we obtain a second order, linear, homogenous equation in the form of:

$$0 = ky + my'' \quad (2)$$

In order to solve this differential equation, a trial solution is assumed as

$$y = A \cos \omega t \quad (3)$$

Or

$$y = B \sin \omega t \quad (4)$$

Substituting equation (3) into (2) produces:

$$0 = (-m\omega^2 + k)A \cos \omega t \quad (5)$$

ω represents the natural frequency of the system and can be calculated by:

$$\omega = \sqrt{k/m} \quad (6)$$

Equations (3) and (4) can be superimposed to produce the second order differential equation:

$$y = A \cos \omega t + B \sin \omega t \quad (7)$$

Differentiating equation (7) with respect to time yields the velocity:

$$y' = A\omega \sin \omega t + B\omega \cos \omega t \quad (8)$$

Differentiating equation (8) with respect to time yields the acceleration:

$$y'' = -A[\omega^2 \cos \omega t + \sin \omega t] + B[-\omega^2 \sin \omega t + \cos \omega t] \quad (9)$$

3.2 Response of one-degree of Freedom System to Harmonic Loading

Because the shaking table creates a sinusoidal ground motion it can be equated to a harmonic motion. Therefore the response of a one-degree-of-freedom system to the shaking table can be calculated.

$$F_0 \sin \omega t = ky + my'' \quad (10)$$

$F_0 = \text{peak amplitude of shaking table}$

$\omega = \text{frequency of force (rad/sec of shaking table)}$

Equation (10) can be taken as:

$$y(t) = y_c(t) + y_p(t) \quad (11)$$

$y_c(t)$ is the complement solution for homogenous differential and can be expressed as equations (7):

$$y_c(t) = A \cos \omega t + B \sin \omega t \quad (7)$$

$y_p(t)$ is the particular solution for the non-homogenous differential and can be expressed as:

$$y_p(t) = Y \sin \omega t \quad (12)$$

$Y = \text{peak}$

$$y_p'(t) = Y\omega \cos \omega t \quad (13)$$

$$y_p''(t) = -Y\omega^2 \sin \omega t \quad (14)$$

Substituting equations (13) and (14) into equation (10) yields

$$-mY\omega^2 + kY = F \quad (15)$$

Solving for Y yields

$$Y = \frac{F}{(k - m \omega^2)} \quad (16)$$

Substituting equations (7), (12) and (16) into equation (11) yields:

$$y(t) = A \cos \omega t + B \sin \omega t + \frac{F_0}{(k - m \omega^2)} \sin \omega t \quad (17)$$

Using the definition of frequency ratio described in the introduction as the relationship of the applied forced frequency to the structure's natural frequency:

$$r = \frac{\omega}{\omega_n} \quad (18)$$

setting time equal to zero to obtain the initial values of A and B yields:

$$A = 0 \quad (19)$$

And

$$B = \frac{-F_0 / K}{1 - r^2} (r) \quad (20)$$

Then substituting equations (18) and (19) into equation (17) yields:

$$y(t) = \frac{F_0 / k}{(1 - r^2)} (\sin \omega t - r \sin \omega t) \quad (21)$$

Damping will cause the $r \sin \omega t$ to disappear and this results in the steady state response of the system as:

$$y(t) = \frac{F_0 / k}{(1 - r^2)} (\sin \omega t) \quad (22)$$

As is demonstrated by this equation as the frequency ratio, r approaches 1, the displacement $y(t)$ approaches infinity. Obviously, failure will occur before this happens.

3.2 Frequencies

For the purpose of the demonstration, our desire is to create a situation that approaches a frequency ratio of 1. The vibration machine operates in frequency units of cycles per second which can be converted to natural frequency with the following equation:

$$\omega = 2\pi f \quad (10)$$

Since the machine shakes the table at 10 - 60 cycles per second, the ideal situation would be a structure with a natural frequency between 63 and 377 radians per second. For practical purposes, a table of calculations was done in Microsoft Excel. The goal of the table, displayed in Table 3.1, was to explore the moment of inertia needed to obtain the desired natural frequency. To achieve this various values of mass, height, and modulus of elasticity (steel and aluminum) were used for calculations. All calculations were done for a one-degree-of-freedom system.

Weight (lbs)	Mass	Omega=2pi*f Omega (rad/s)	k=mw^2	Height (in)	Aluminum		Steel	
					k=12EI/h^3 I	k=3EI/h^3 I	k=12EI/h^3 I	k=3EI/h^3 I
80	0.207	50	518	36	0.188	0.752	0.0693939	0.277575
80	0.207	150	4,658	40	2.322	9.288	0.8567145	3.426858
80	0.207	250	12,940	44	8.585	34.339	3.1674639	12.66986
80	0.207	350	25,362	48	21.845	87.379	8.05997	32.23988
90	0.233	50	582	36	0.212	0.846	0.0780681	0.312272
90	0.233	150	5,241	40	2.612	10.449	0.9638038	3.855215
90	0.233	250	14,557	44	9.658	38.631	3.5633969	14.25359
90	0.233	350	28,533	48	24.575	98.302	9.0674663	36.26987
100	0.259	50	647	36	0.235	0.940	0.0867423	0.346969
100	0.259	150	5,823	40	2.902	11.610	1.0708931	4.283572
100	0.259	250	16,175	44	10.731	42.924	3.9593299	15.83732
100	0.259	350	31,703	48	27.306	109.224	10.074963	40.29985
110	0.285	50	712	36	0.259	1.034	0.0954166	0.381666
110	0.285	150	6,405	40	3.193	12.771	1.1779824	4.71193
110	0.285	250	17,792	44	11.804	47.216	4.3552628	17.42105
110	0.285	350	34,873	48	30.037	120.146	11.082459	44.32984

Table 3.1 Projected I Values.

Based on the values of moment of inertia found in the table, aluminum was chosen as the most readily available material.

3.3 Staadpro Simulation

The intention of the project was to produce a structure that was two stories. Exploring the multiple degrees of freedom of a structure gets very complicated. Various software products are available to analyze structures. StaadPro was used to

design and evaluate multiple structures for their suitability in this project.

First, single story structures were designed and their natural frequencies analyzed with StaadPro. The natural frequencies obtained through this analysis matched the hand calculations. Next, two story plane structures were designed and their first and second modal frequencies were analyzed. Various size beams, and masses were examined. A Microsoft Excel table showing the modal frequencies is displayed in Table 3.2.

2bays	Beam Size	Bay Height	Member Weight	Total Weight	Deflection inches	Modal Frequencies	
						1	2
1	1 x 0.125	18 in each	5lb/in	60/120	0.3475	80.5	210
2	1 x 0.125	18 in each	5lb/in	60/120	0.34665	80.9	211
3	0.75 x 0.065	18 in each	5lb/in	60/120	3.706	49.32	129.1
4	0.75 x 0.065	18 in each	2lb/in	24/48	1.48246	77.9	204
5	1 x 0.125	18 in each	2lb/in	24/48	0.139	127.3	333
6	0.5 x 0.0625	18 in each	2lb/in	24/48	2.22369	63.66	166.66
7	0.5 x 0.0625	18 in each	5lb/in	60/120	5.55921	40.27	105.4
8	0.5 x 0.0313	18 in each	5lb/in	60/120	0.1814	27.89	73.05

Table 3.2 First and Second Modal Frequencies.

3.4 Design and Construction

Based on the StaadPro analyses, material availability was researched. To

simplify construction and ensure stability, a three dimensional model with four column supports was designed. The model is composed of two modes – each one

level with four columns, two braces, a floor, a roof and two masses. To explore the effects of the different variables, the bracings and masses are removable.

The columns and bracings are made from 1 x 1/8 x 18 inch aluminum. The floors and roofs are made from 1/2 inch plywood. The masses are 9 x 12 x 1 3/4 inch concrete slabs each weighing 15 lbs. The design of the structure is

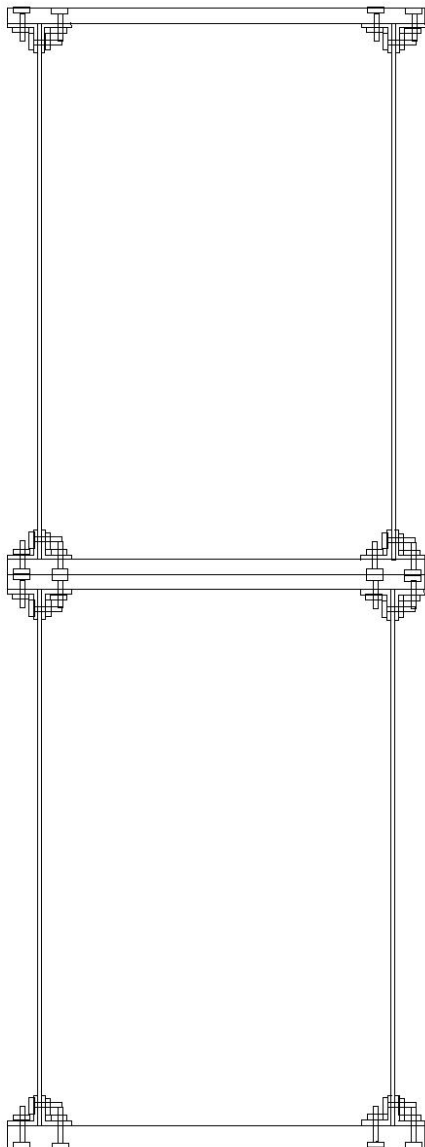

Figure 3.2 – Design of Structure.

illustrated in Figure 3.2. The complete set of design drawings is in Appendix B. In order to ensure fixed joints, angles were fabricated from 1 x 1 x 1/8 inch steel angles. A bracing form was assembled to create consistent drilling on the angles, that bracing form is illustrated in Figure 3.3. Additional photos of the fabrication process are shown in Figure 3.3, Figure 3.4 and Figure 3.5



Figure 3.3 – Bracing Form for Angles.



Figure 3.4 Fabrication Process.



Figure 3.5 – Fabrication Process.



Figure 3.6 Fabrication Process.

4.0 Experiment

4.1 Staadpro Prediction

Once the actual structural model was constructed, the simulation was rebuilt in StaadPro. Now with exact dimensions and masses, StaadPro was used to predict the effects of the ground motion on the structure. Six situations were explored in StaadPro – each of the mass possibilities (floor only, one concrete slab per floor, and two concrete slabs per floor) with and without bracing. A time history for ground motion was calculated and entered. A sinusoidal, acceleration function was set with a frequency of 20 hertz and an amplitude of 197.417 ft/sec^2 .

The analysis predicted a maximum nodal displacement of 1.095 inches on the unbraced structure with both masses attached to each floor. Figure 4.1 is StaadPro's illustration of this displacement. The maximum predicted displacement for the unbraced structure with one mass on each floor was 0.454 inches. Figure 4.2 is StaadPro's illustration for this displacement. StaadPro predicted the minimum nodal displacement on the unbraced structure with no additional masses attached. StaadPro's illustration of that displacement is in Figure 4.3. Additionally, Appendix C contains one Time History Report and two StaadPro Analysis Output files.

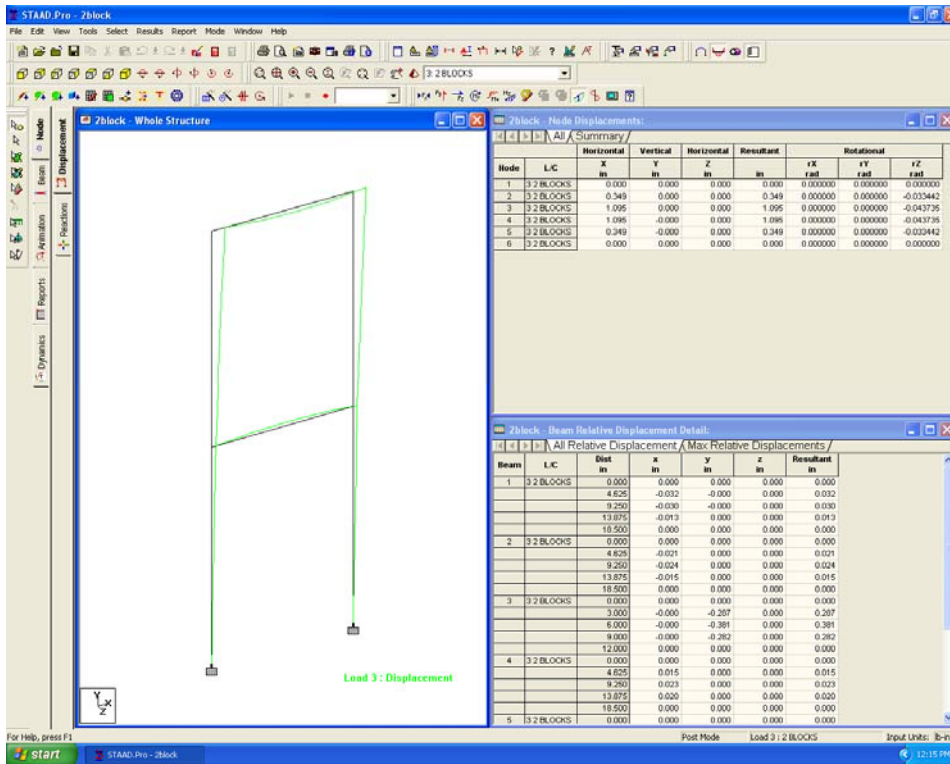

Figure 4.1 – Nodal Displacement of 2 Masses per Floor.

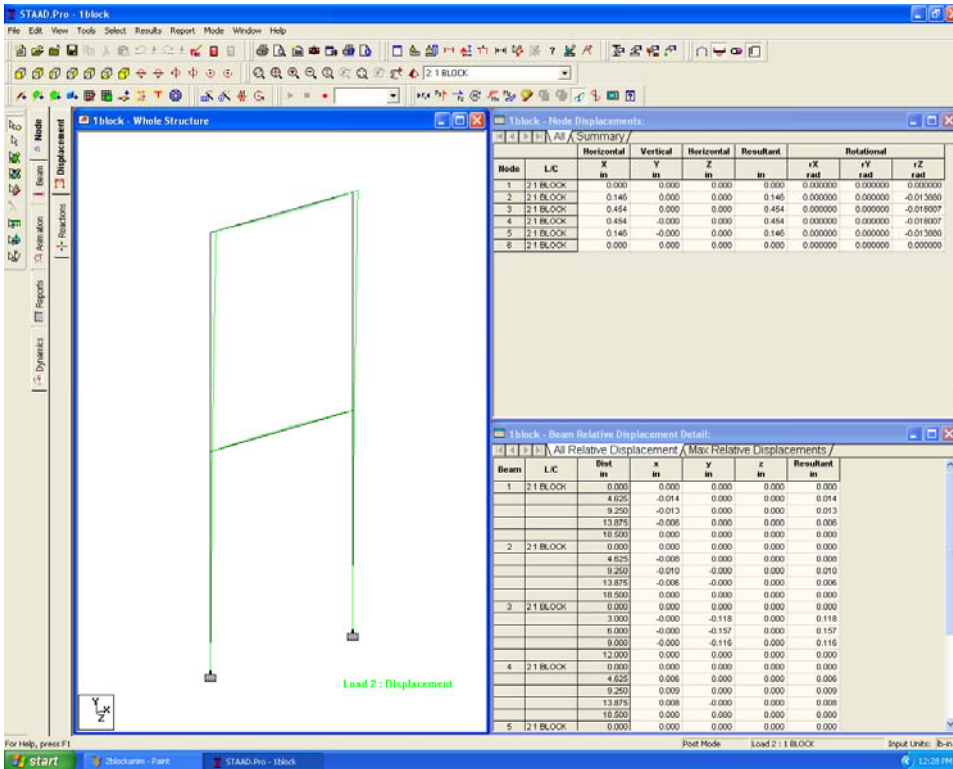

Figure 4.2 – Nodal Displacement of One Mass per Floor.

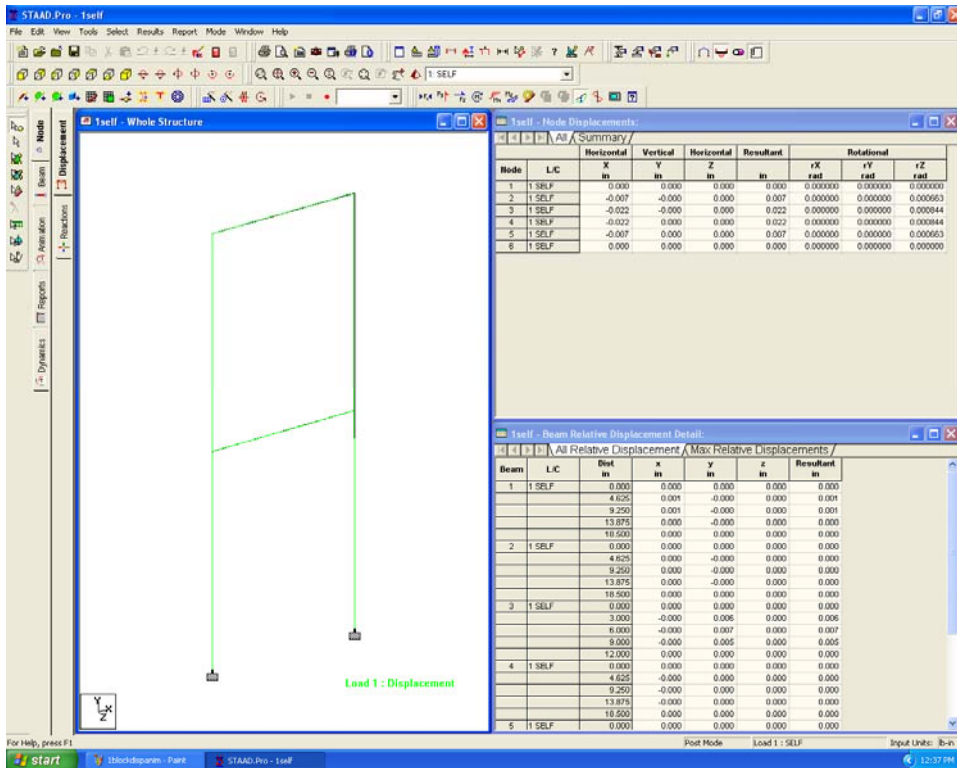

Figure 4.3 – Nodal Displacement of No Additional Masses.

4.2 Structural Response

After the responses were predicted in StaadPro, the structure was assembled and attached to the shaking table. A simulation was run for each of the possible structural conditions – no additional mass, one mass per floor and two masses per floor – each with and without bracing. As predicted by

StaadPro, the unbraced structure with two masses per floor (weighing 30 pounds per floor) had the most extreme response. Interestingly, when the frequency of the shaking table was adjusted, the braced structure with no additional masses had the most extreme response. That was the only condition that a bolt was actually thrown loose. Figure 4.4, Figure 4.5, and Figure 4.6 are some photos of various stages of the simulation.



Figure 4.4 – Unbraced Structure with One Mass per Floor.



**Figure 4.5 – Braced
No additional mass**



**Figure 4.6 – Braced
One Mass per Floor**



**Figure 4.7 Braced
Two Masses per Floor**

5.0 Appendix

5.1 Appendix A – Autocad Drawings

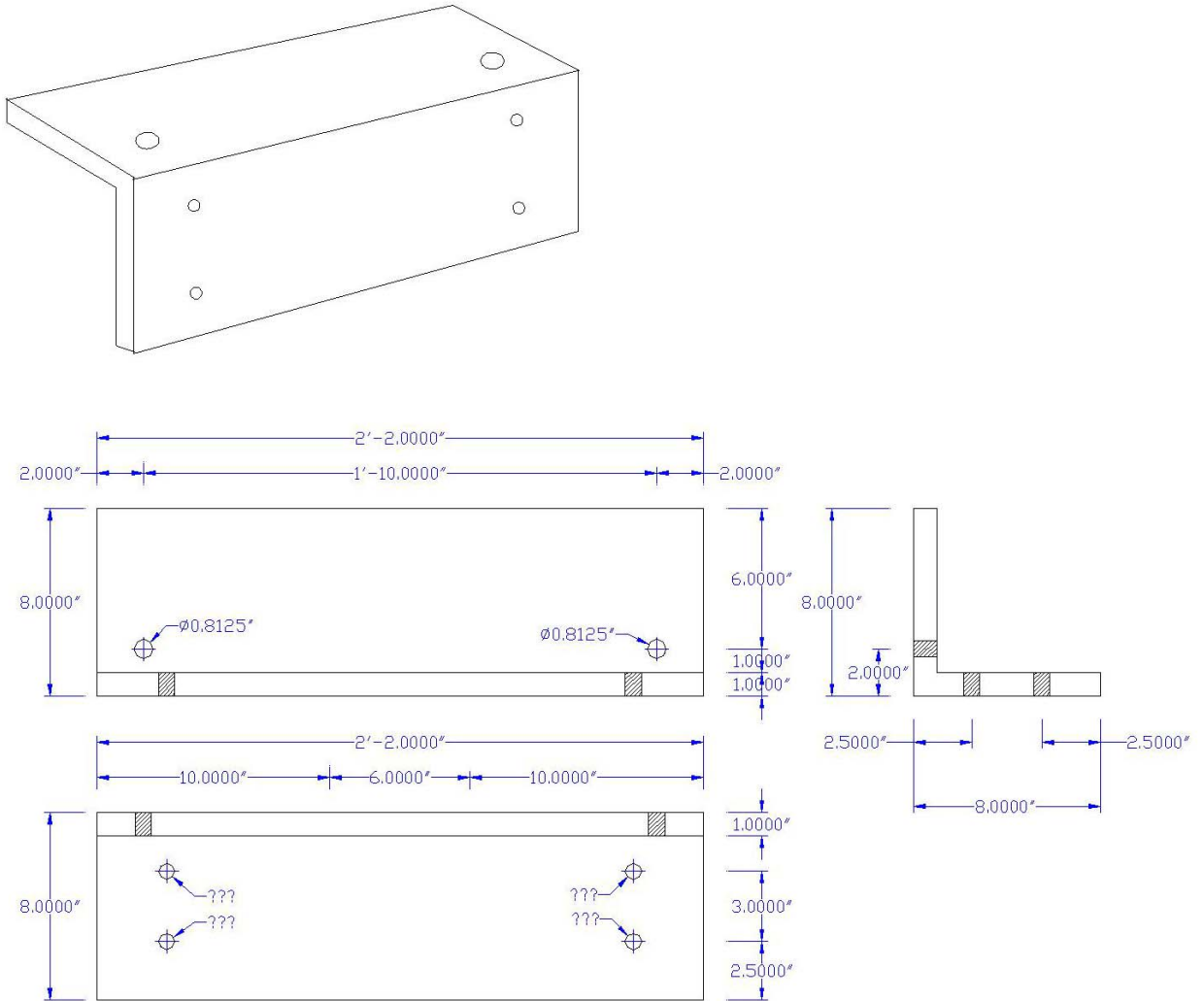

Figure A1.1 – AutoCAD Drawing of Foundation End.

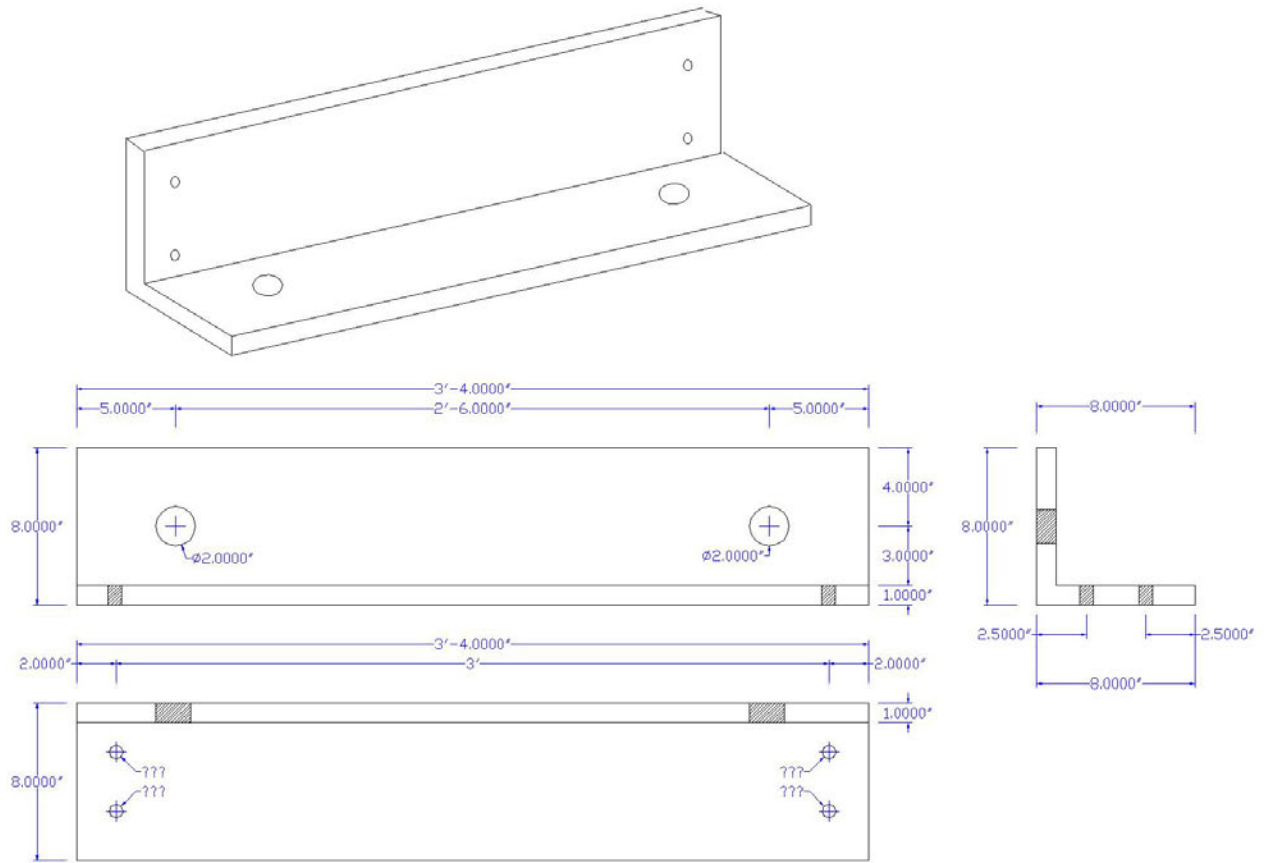

Figure A1.2 – AutoCAD Drawing of Foundation Sides.

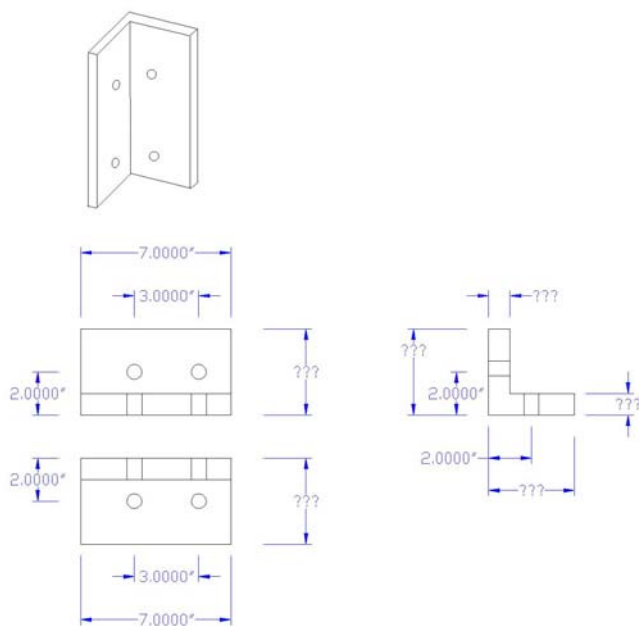

Figure A1.3 – AutoCAD Drawing of Foundation Connectors.

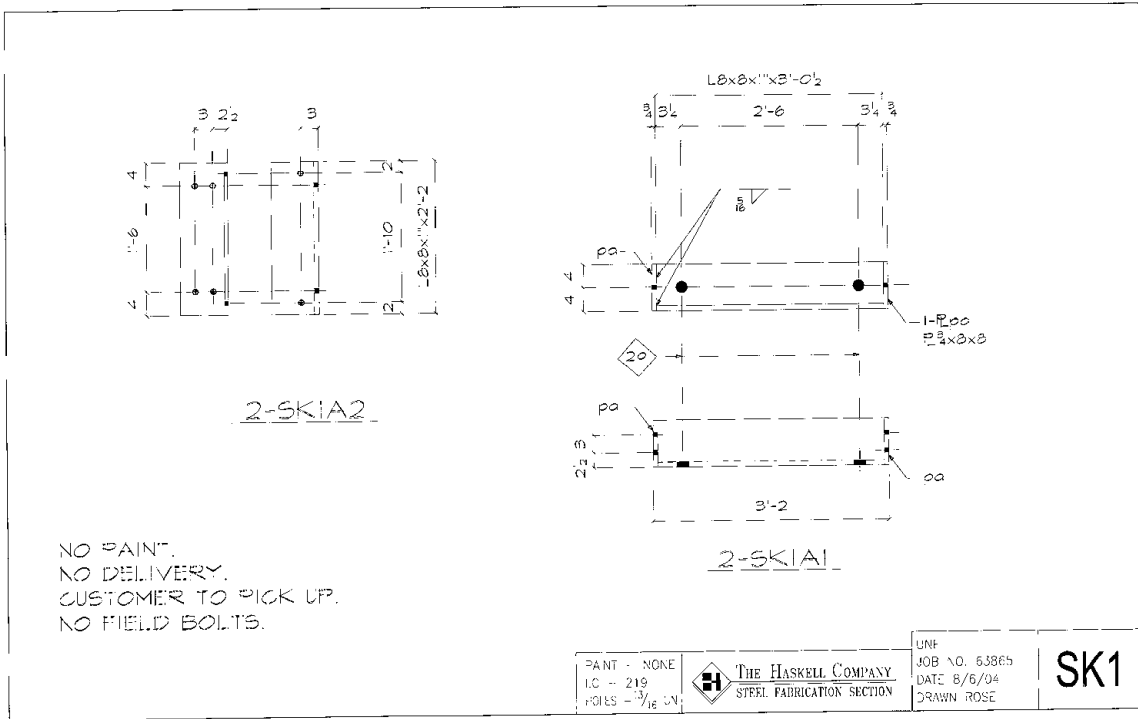

Figure A1.4 – Shop Drawing of Foundation.

5.2 Appendix B – Structural Model Drawings

5.3 Appendix C – Staadpro Report and Output