

Summer 7-22-2013

The Developmental Regulation of Gene and Cellular Networks in Locomotion

Manali Rupji
Georgia State University

Follow this and additional works at: https://scholarworks.gsu.edu/biology_theses

Recommended Citation

Rupji, Manali, "The Developmental Regulation of Gene and Cellular Networks in Locomotion." Thesis, Georgia State University, 2013.
https://scholarworks.gsu.edu/biology_theses/51

This Thesis is brought to you for free and open access by the Department of Biology at ScholarWorks @ Georgia State University. It has been accepted for inclusion in Biology Theses by an authorized administrator of ScholarWorks @ Georgia State University. For more information, please contact scholarworks@gsu.edu.

THE DEVELOPMENTAL REGULATION OF GENE AND CELLULAR NETWORKS IN LOCOMOTION

by

MANALI RUPJI

Under the Direction of Dr. Walthall

ABSTRACT

A process such as locomotion requires a well-connected cellular network that is assembled by a gene network. *Caenorhabditis elegans* offers a tractable model system allowing integrative studies of gene and cellular networks. We have combined bioinformatics and cellular approaches to investigate such networks. The D motoneurons compose a cross – inhibitory network essential for sinuous locomotion. Its terminal selector gene, *unc-30* establishes the anatomical and neurochemical fates in these neurons. Three genes: *unc-5*, *flp-11* and *unc-104* are expressed in the D mns as well as other motoneuron classes. Using transcriptional reporters, we found that UNC-30 influenced the expression of each of these genes; however, in the most broadly expressed of the genes, *unc-104*, the impact of UNC-30 was less obvious. The bioinformatics analysis identified the cis-element for *alr-1*, in the promoters of all three genes. *unc-30;alr-1* double mutant studies suggested that the two transcription factors act synergistically in regulating *unc-104*.

INDEX WORDS: Class specific, UNC-30, ALR-1, gene network, cellular network, neuromuscular junction, *Caenorhabditis elegans*.

THE DEVELOPMENTAL REGULATION OF GENE AND CELLULAR NETWORKS IN LOCOMOTION

by

MANALI RUPJI

A Thesis Submitted in Partial Fulfillment of the Requirements for the Degree of

Master of Science

in the College of Arts and Sciences

Georgia State University

2013

Copyright by
Manali Rupji
2013

THE DEVELOPMENTAL REGULATION OF GENE AND CELLULAR NETWORKS IN LOCOMOTION

by

MANALI RUPJI

Committee Chair: Walter W. Walthall

Committee: Casonya Johnson

John E. Houghton

Electronic Version Approved:

Office of Graduate Studies

College of Arts and Sciences

Georgia State University

August 2013

DEDICATION

To my parents and twin brother, who have always been my strengths.

ACKNOWLEDGEMENTS

I would like to take this opportunity to thank my PI, Dr. Walthall for the immense support, guidance and patience without which this project would have not been as it stands today. Under your guidance, I have learnt the essence of genetic processes. I would also like to thank my committee, Dr. Johnson and Dr. Houghton for their constructive feedback during the project.

I would also like to extend my gratitude to the Department of Biology, the graduate coordinators Latesha Warren and Moneka Jones for always being there to answer queries. I would like to sincerely thank Vaishali Garg, Richard Campbell, Abir Rahman, Mohammad Tariq, Shelley Hinkle, Crystal Sheldon, Taylor Packard, Jasmine Fisher and the other members of my lab for their constant support.

I would sincerely like to thank my friends in Atlanta, Sanam Dharma, Aarti Mishra, Shyam Rajaram, Rutugandha Paranjpe and Vidhi Thakkar for the helping me out in their own special ways. Their constant encouragement throughout has helped me realize my true potential in research.

Lastly, I would like to thank my parents and my brother for showing faith in me and for their patience during my research.

TABLE OF CONTENTS

ACKNOWLEDGEMENTS	v
LIST OF TABLES.....	viii
LIST OF FIGURES.....	ix
1 INTRODUCTION	1
2 MATERIALS AND METHODS.....	12
2.1 <i>C. elegans</i> worm maintenance, reporter strains, phenotype and genetics	12
2.2 Analysis of the transgenic worms.....	14
2.3 Intensity Measures and Statistical analysis	14
2.4 Bioinformatics analysis	14
2.4.1 <i>Sequence Isolation and inter-species conservation</i>.....	14
2.4.2 <i>Transcription factor analysis</i>.....	15
3 RESULTS.....	17
3.1 <i>unc-30</i> is the master control gene for the D type GABAergic mns	17
3.1.1 <i>Positive control: punc-25::gfp</i>.....	18
3.1.2 <i>Neuropeptide: flp-11</i>	22
3.1.3 <i>Netrin receptor: unc-5</i>.....	27
3.1.4 <i>Kinesin motor : unc-104</i>	31
3.2 ALR-1 is necessary for the regulation of reporters in the cholinergic motor neurons	36
3.2.1 <i>unc-5 gene reporter</i>	38
3.2.2 <i>unc-104 gene reporter</i>	40

3.2.3	<i>flp-11 gene reporter</i>	41
3.3	<i>unc-30, alr-1</i> double mutants show loss of both GABAergic and cholinergic expression	44
3.3.1	<i>pflp-11::gfp reporter</i>	44
3.3.2	<i>punc-5::gfp reporter</i>	48
3.3.3	<i>punc-104::gfp reporter</i>	51
4	DISCUSSION.....	56
	REFERENCES.....	61

LIST OF TABLES

Table 1.1: The lineages of the embryonic cells derived from one of the six founder cell AB. a, p represent the anterior and posterior counterpart of the subsequent divisions while r, l represent the perpendicularly divided cell (Sulston et al., 1983).	5
Table 2.1: Reporter strains	13
Table 3.1 : modENCODE analysis of the promoters of the three gene reporters.	37

LIST OF FIGURES

Figure 1.1 : Cross-inhibitory cell network includes the excitatory and inhibitory mns responsible for locomotion in <i>C. elegans</i>	2
Figure 1.2 : The positions of the embryonic mns in the VNC. (Sulston et al., 1983)	4
Figure 1.3 : (A) Positions of the embryonic mns along the VNC and the postembryonic blast cells as they migrate towards the nerve cord. (B) Postembryonic cell division pattern (Walthall, 1995).	6
Figure 1.4 : Segmental repeats in the post embryonic cells in the VNC in <i>C. elegans</i> . Adapted from wormatlas.org.	7
Figure 1.5 : (A, B) Change in expression of <i>pflp-13::gfp</i> reporter in wt and <i>unc-30 (e191)</i> background. (C, D) Expression when the UNC-30 binding site has been mutated (Shan et al., 2005).	9
Figure 3.1: Consensus binding site for UNC-30 (Cinar et al., 2005)	17
Figure 3.2 : (A, B, C) Comparison of expression in wild type <i>punc-25::gfp</i> and in both <i>unc-30</i> alleles (<i>e191</i> and <i>ok613</i>) in L1 stage. Left is anterior, right is posterior, dorsal is up and ventral is down in all the preps. Scale is 50 μ m. (D) Graph represents the change in the intensity in the DDs at L1 stage with respect to the head neuron. n=27, 31 and 20 for wt, <i>e191</i> and <i>ok613</i> mutant backgrounds. Significance calculated using the student's t test where * $p < 0.05$, ** $p < 0.005$, *** $p < 0.001$	20
Figure 3.3 : (A, B, C) Comparison of expression in wild type <i>punc-25::gfp</i> and in both <i>unc-30</i> alleles (<i>e191</i> and <i>ok613</i>) in L2 stage. Left is anterior, right is posterior, dorsal is up and ventral is down in all the preps. Scale is 50 μ m. (D, E) Graphs represent the change in the intensity in the DDs and VDs at L2 stage with respect to the head neuron. n=11, 9 and 16 for wt, <i>e191</i> and <i>ok613</i> mutant backgrounds. Significance calculated using the student's t test where * $p < 0.05$, ** $p < 0.005$, *** $p < 0.001$	21
Figure 3.4 : Allignment of the <i>flp-11</i> gene promoter and the first exon and introns to identify regions of conservation within <i>C. elegans</i> , <i>C. briggsae</i> and <i>C. remanei</i> using MUSSA. 2000 base-pairs from the +1 TSS was used. Black bars indicate the DNA sequence, Red regions indicate the areas of conservation in	

the plus strand of the DNA. Blue box indicates the location of the UNC-30 binding sites within these conserved areas using the consensus five base pair binding sites. Maroon represents TAATC while yellow represent the GATTA sites. 22

Figure 3.5 : Transcription factor binding site analysis on the *flp-11* gene promoter using TESS and MatInspector..... 23

Figure 3.6 : (A, B, C) Change of expression in wild type *pflp-11::gfp* in two *unc-30* alleles (*e191* and *ok613*) in L1 stage. Both worms are placed ventral up. Scale is 50 μ m. (D) Graph represents the change in the intensity in the DDs at L1 stage with respect to the head neuron. n=24, 39 and 23 for wt, *e191* and *ok613* mutant backgrounds. Significance was calculated using the student's t test where * p<0.05, ** p<0.005, *** p<0.001. 25

Figure 3.7 : (A, B, C) Comparison of expression in wild type *pflp-11::gfp* and in both *unc-30* alleles (*e191* and *ok613*) in the L2 stage. Left is anterior, and dorsal is up in all the preps. Scale is 50 μ m. (D, E) Graphs represent the change in the intensity in the DDs and VDs at L2 stage with respect to the head neuron. n=19, 21 and 20 for wt, *e191* and *ok613* mutant backgrounds. Significance calculated using the student's t test where * p<0.05, ** p<0.005, *** p<0.001. 26

Figure 3.8 : Comparison of the *unc-5* gene promoter and the first exon and introns to isolate regions of conservation within *C. elegans*, *C. briggsae* and *C. remanei* using MUSSA. 2000 base pairs from the +1 TSS were used. Black bars indicate the DNA sequence, Red regions indicate the areas of conservation in the plus strand of the DNA while the blue region represents the alignment in the reverse complement strand. Blue box indicates the location of the UNC-30 binding sites within these conserved areas using the consensus five base pair binding sites. Maroon represents TAATC while yellow represent the GATTA sites..... 27

Figure 3.9 : Transcription factor binding site analysis on the *unc-5* promoter using TESS and MatInspector..... 28

Figure 3.10: (A, B, C) Comparison of expression in wild type *punc-5::gfp* and in both *unc-30* alleles (*e191* and *ok613*) in L1 stage. Left is anterior, right is posterior, dorsal is up and ventral is down in all the preps. Scale is 50 μ m. (D) Graph represents the change in the intensity in the DDs at L1 stage with respect to the head neuron. n=17, 18 and 9 for wt, *e191* and *ok613* mutant backgrounds. Significance calculated using the student's t test where * p<0.05, ** p<0.005, *** p<0.001 30

Figure 3.11 : Comparison of the *unc-104* gene promoter and the first exon and introns to isolate regions of conservation within *C. elegans*, *C. briggsae* and *C. remanei* using MUSSA. 2000 base pairs from the +1 TSS was used. Black bars indicate the DNA sequence; Red regions indicate the areas of conservation in the plus strand of the DNA while the blue region represents the alignment in the reverse complement strand. Black box indicates the location of the UNC-30 binding sites (TAATC) (in maroon) within these conserved areas using the consensus five base pair binding sites. 31

Figure 3.12 : Comparison of the *unc-104* gene promoter and the first exon and introns to isolate regions of conservation within *C. elegans*, *C. briggsae* and *C. remanei* using MUSSA. 2000 base pairs from the +1 TSS were used. 32

Figure 3.13 :(A, B, C) Comparison of expression in wild type *punc-104::gfp* and in both *unc-30* alleles (*e191* and *ok613*) in L1 stage. Left is anterior, right is posterior, dorsal is up and ventral is down in all the preps. Scale is 50 μ m. (D) Graph represents the change in the intensity in the DDs at L1 stage with respect to the head neuron. n=21, 20 and 19 for wt, *e191* and *ok613* mutant backgrounds. Significance calculated using the student's t test where * p<0.05, ** p<0.005, *** p<0.001. 34

Figure 3.14 :(A, B, C) Comparison of expression in wild type *punc-104::gfp* and in both *unc-30* alleles (*e191* and *ok613*) in L2 stage. Left is anterior and dorsal is up in all the preps. Scale is 50 μ m. (D, E) Graph represents the intensity in the DDs at L2 stage with respect to the head neuron. n=14, 16 and 8 for wt, *e191* and *ok613* mutant backgrounds. Significance calculated using the student's t test where * p<0.05, ** p<0.005, *** p<0.001 35

Figure 3.15 : (A, B) Comparison of expression in wild type *punc-5::gfp* and in *alr-1 (oy42)* in L1 stage. n=17 and 23 for wt and *alr-1* mutant backgrounds respectively. (C) Expression of *punc-5::gfp* in the *alr-1* mutant background in the L2 stage. Left is anterior, right is posterior, dorsal is up and ventral is down in all the preps. Scale is 50 μ m. n=4 and 13 for wt and *alr-1* mutant backgrounds respectively. ... 39

Figure 3.16 : (A, B) Comparison of expression in wild type *punc-104::gfp* and in *alr-1 (oy42)* in L1 stage. n=21 and 24 for wt and *alr-1* mutant backgrounds respectively. (C, D) Comparison of expression in wild type *pflp-11::gfp* and in *alr-1 (oy42)* in L2 stage. n=14 and 23 for wt and *alr-1* mutant backgrounds respectively. Left is anterior, right is posterior, dorsal is up and ventral is down in all the preps. Scale is 50 μ m..... 41

Figure 3.17 : (A, B) Comparison of expression in wild type *pflp-11::gfp* and in *alr-1 (oy42)* in L1 stage. n=24 and 11 for wt and *alr-1* mutant backgrounds respectively. (C, D) Comparison of expression in wild type *pflp-11::gfp* and in *alr-1 (oy42)* in L2 stage. n=19 and 12 for wt and *alr-1* mutant backgrounds respectively. Left is anterior, right is posterior, dorsal is up and ventral is down in all the preps. Scale is 50 μ m..... 43

Figure 3.18: (A, B, C) Comparison of expression in wild type *pflp-11::gfp* and in the absence of *unc-30 (e191)* and in the absence of both *unc-30 (e191)* and *alr-1* in L1 stage. All worms are placed ventral up. Scale is 50 μ m. (D) Graph represents the change in the intensity in the DDs at L1 stage with respect to the head neuron. n= 24, 40 and 25 for wt, *e191* and *e191, alr-1* mutant backgrounds. Significance calculated using the student's t test where * p<0.05, ** p<0.005, *** p<0.001. 46

Figure 3.19 : (A, B, C) Comparison of expression in wild type *pflp-11::gfp*, *unc-30 (e191)* and double mutants, *unc-30 (e191); alr-1* in L2 stage. Left is anterior, right is posterior, dorsal is up and ventral is down in all the preps. Scale is 50 μ m. (D, E) Graphs represent the change in the intensity in the DDs and VDs at L2 stage with respect to the head neuron. n=19, 21 and 16 for wt, *e191* and *e191; alr-1* double

mutant backgrounds. Significance calculated using the student's t test where * p<0.05, ** p<0.005, *** p<0.001. 47

Figure 3.20 : (A, B, C) Comparison of expression in wild type *punc-5::gfp, unc-30 (e191)* and in double mutants *unc-30 (e191); alr-1* in L1 stage. Left is anterior, right is posterior, dorsal is up and ventral is down in all the preps. Scale is 50 μm. (D) Graph represents the change in the intensity in the DDs at L1 stage with respect to the head neuron. n=17, 18 and 28 for wt and *e191, alr-1* double mutant backgrounds. Significance calculated using the student's t test where * p<0.05, ** p<0.005, *** p<0.001 50

Figure 3.21 : Expression in *punc-5::gfp* double mutants *unc-30 (e191); alr-1* in L2 stage. Left is anterior, right is posterior, dorsal is up and ventral is down. Scale is 50 μm. n= 14. 51

Figure 3.22 : (A, B, C) Comparison of expression in wild type *punc-104::gfp, unc-30 (e191)* and in double mutants *unc-30 (allele e191); alr-1* in L1 stage. Left is anterior, right is posterior, dorsal is up and ventral is down in all the preps. Scale is 50 μm. (D) Graph represents the change in the intensity in the DDs at L1 stage with respect to the head neuron. n=21, 20 and 25 for wt, *e191* and *e191, alr-1* double mutant backgrounds. Significance calculated using the student's t test where * p<0.05, ** p<0.005, *** p<0.001 53

Figure 3.23: (A, B, C) Comparison of expression in wild type *punc-104::gfp, unc-30(e191)* and in double mutants *unc-30 (e191); alr-1* in L2 stage. Left is anterior, right is posterior, dorsal is up and ventral is down in all the preps. Scale is 50 μm. (D, E) Graph represents the change in the intensity in the DDs at L2 stage with respect to the head neuron. n=14, 16 and 12 for wt, *e191* and *e191, alr-1* double mutant backgrounds. Significance calculated using the student's t test where * p<0.05, ** p<0.005, *** p<0.001 54

LIST OF ABBREVIATIONS

A	Anterior
ACh	Acetylcholine
D	Dorsal
GABA	Gamma-aminobutyric acid
GFP	Green Fluorescence Protein
L	Larval Stage
LSM	Laser Scanning Microscope
mns	motor neurons
NGM	Nematode Growth Media
P	Posterior
p	probability
TSS	Transcription start site
V	Ventral
VNC	Ventral nerve cord

1 INTRODUCTION

The human body orchestrates various processes necessary for its survival. Breathing, ingestion and locomotion are some of the basic processes that require well-organized cellular networks of nerves and muscles. The assembly of cellular networks is regulated by gene networks. Based upon emergent results from nematode to mammals, it has become apparent that many of these gene networks have been conserved evolutionarily. Due to the ease of genetic manipulations, *Caenorhabditis elegans*, provides a model system that allows researchers to investigate the relationships between gene networks and cellular networks.

A number of key genes play central roles in organizing multicellular animals. The best example is the homeobox gene cluster. This gene complex is critical for regional specification and patterning along the longitudinal axis during embryonic development. It has been shown to be conserved across fungi (Kim et al., 2009), sponges (Degnan et al., 1995), insects (Akin and Nazarali, 2005), plants (Williams, 1998) and humans (Lappin et al., 2006) (Wang et al., 1993, Gehring et al., 1994, Heffer et al., 2010). The central question here is the extent to which the associated gene networks are conserved among different species. Beginning with a selected transcription factor it is possible to identify downstream genes in the network using the bioinformatics approach of phylogenetic footprinting. Using closely related *Caenorhabditis* species (*C. elegans*, *C. briggsae* and *C. remanei*), phylogenetic conservation analysis on the promoters can be performed (Kuntz et al., 2008). Transcription factor binding sites or clusters can be identified in these conserved promoter regions in the orthologous species.

In the mammalian cortex, projection neurons from primary visual, motor and somatosensory cortex initially send identical projections to a variety of regions outside of the cortex. Subsequently differential pruning and branching sculpts neurons to achieve their final morphology (O'Leary and Nakagawa, 2002). This suggests that the same gene network regulates process guidance in the entire

class of layer 5 projection neurons. We propose that related classes of mns in *C. elegans* are generated from the same or similar genetic programs that are controlled by terminal selector genes that regulate the expression of many if, if not all genes within the network. An important question is to understand, is the relationship between terminal selector genes and genes that are expressed in multiple gene networks.

C. elegans moves in a sinusoidal wavelike motion. This sinusoidal wave is created by a network of nerves and muscles located along the dorsal and ventral side of the animal. There are eight classes of mns involved in locomotion. Of the eight classes, six are excitatory and two are inhibitory. These two classes, along with the muscles they innervate, form a cross inhibitory network that contribute to the sinuous pattern of locomotion (Figure 1.1). The excitatory motor neurons release acetylcholine (ACh) onto the muscles causing them to contract. At the same time, they activate the inhibitory motor neurons to release GABA on the opposite muscle cells causing relaxation. These alternate contractions on one side and relaxation on the other propels the nematode forward and backward.

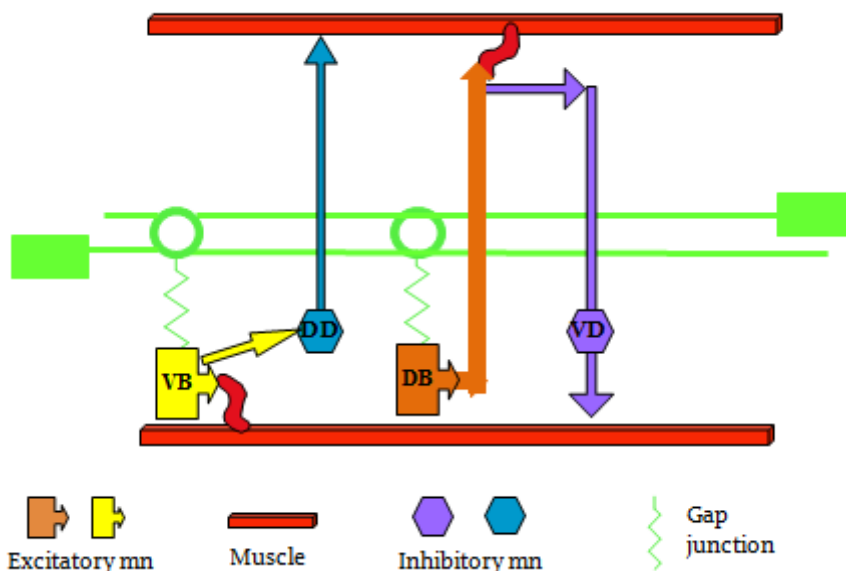

Figure 1.1 : Cross-inhibitory cell network includes the excitatory and inhibitory mns responsible for locomotion in *C. elegans*.

The cell bodies of the eight classes of mns assume predictable positions in the ventral nerve cord (VNC). They are generated at different developmental times and from different cellular lineages. The embryonic mns include the DA, DB and the DD classes, and the VA, VB, AS and VC motorneuron classes are generated postembryonically (Figure 1.2, Figure 1.4; (Sulston and Horvitz, 1977, Sulston et al., 1983))

In nematodes, insects and annelids, the mns are arranged in a segmented or segment-like repeats in the VNC. The Hox gene cluster plays a key role in creating repeated cellular patterns along the longitudinal axis of an animal (Wang et al., 1993). A classical example of patterning of this kind is seen in *Drosophila* and has been also observed in mammals. In *Drosophila*, 14 segments are observed in the embryo. This portioning is achieved by an interplay of segmentation genes : gap genes, pair ruled genes and segment polarity genes (Rivera-Pomar and Jackle, 1996). However in nematodes, an autonomous lineal mechanism generates the embryonic mns, no repeating pattern of blast cell lineages is seen in these embryonic cells (Hedgecock et al., 1985, Walthall, 1995). Conversely, post embryonic motor neurons are generated by 12 blast cells located sublaterally in newly hatched animals and distributed along the length of the animal. These blast cells migrate towards the VNC and follow identical patterns of division to create five different classes of motor neurons and hypodermal cells (Figure 1.3). The fate of these mn classes vary according to their positions along the longitudinal axis. What is observed is that these postembryonic mns form periodic repeats having clusters of closely related cells. Eight such repeats can be observed in the region between the retro-vesicular ganglion to the pre-anal ganglion (Figure 1.4).

In insects, ventral ectodermal cells, recruit CNS neuroblasts in a pattern that is repeated along the anterior posterior axis (Doe and Goodman, 1985). These cells continue to divide in identical lineages and form segmental ganglia along the VNC. In annelids, individual founder cells along the anterior posterior axis, form germ bands through symmetrical divisions, which give rise to segmental ganglia along the VNC (Shankland, 1991).

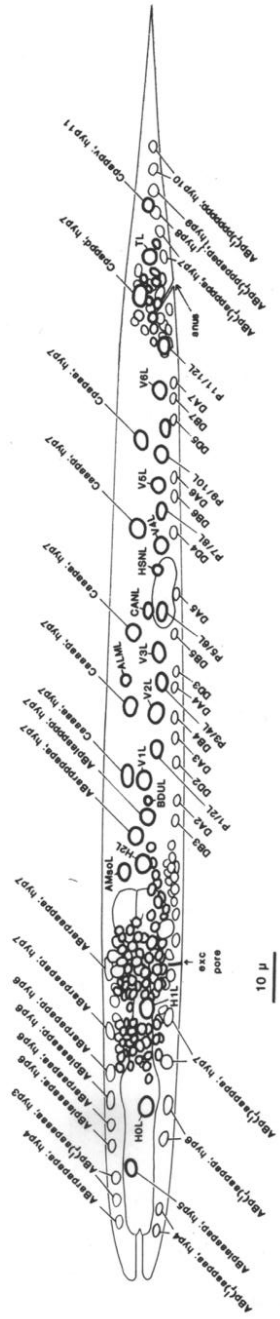

Figure 1.2 : The positions of the embryonic mns in the VNC. (Sulston et al., 1983)

Table 1.1: The lineages of the embryonic cells derived from one of the six founder cell AB. a, p represent the anterior and posterior counterpart of the subsequent divisions while r, l represent the perpendicularly divided cell (Sulston et al., 1983).

DD1	AB.plppappap	DA1	AB.prppapaap	DB 1/3	AB.plpaaaapp
DD3	AB.plppapppa	DA3	AB.prppapapa	DB5	AB.plpapappp
DD5	AB.plppapppp	DA5	AB.prppapapp	DB6	AB.plppaappp
		DA7	AB.prpppaaap		
DD2	AB.prppappap	DA8	AB.prpapappp	DB2	AB.arappappa
DD4	AB.prppapppa				
DD6	AB.prppapppp	DA2	AB.plppapapa	DB3/1	AB.prpaaaapp
		DA4	AB.plppapapp	DB4	AB.prpappapp
		DA6	AB.plpppaaap	DB7	AB.prppaappp
		DA9	AB.plpppaaaa		

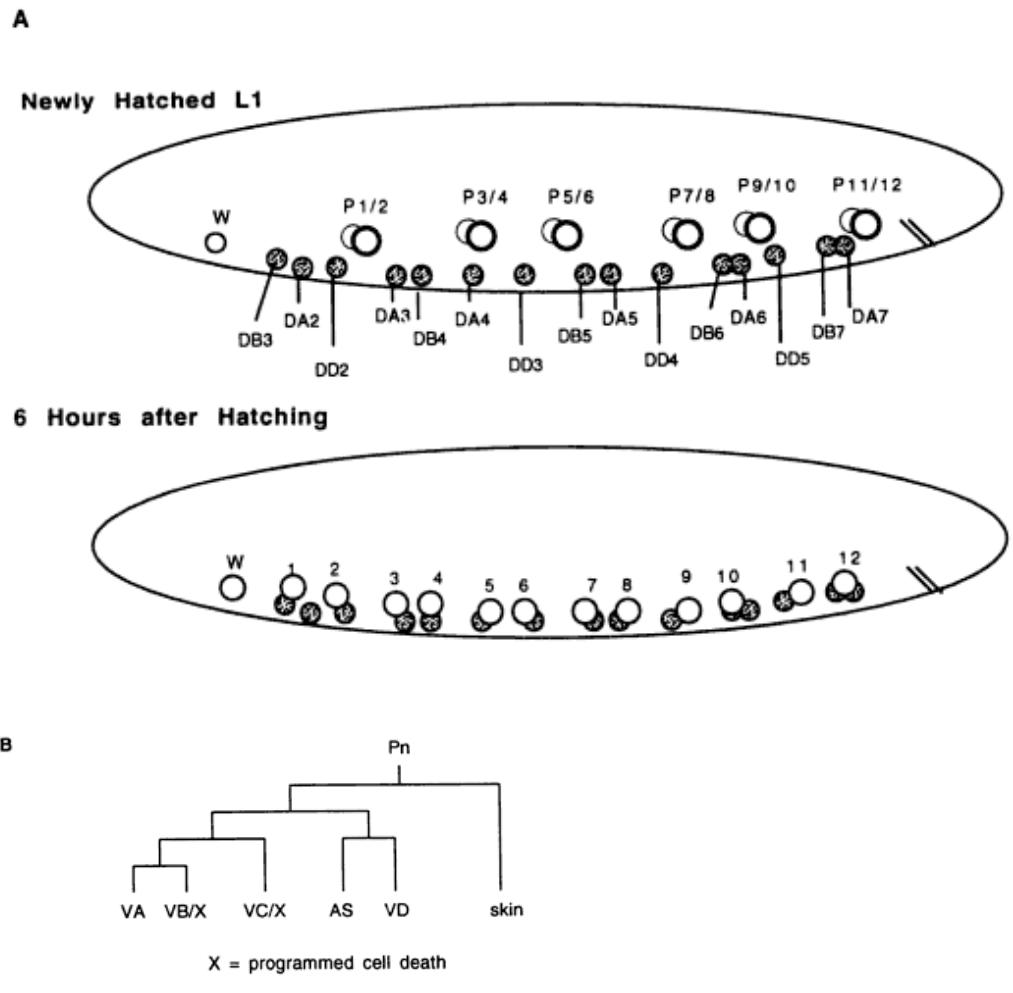

Figure 1.3 : (A) Positions of the embryonic mns along the VNC and the postembryonic blast cells as they migrate towards the nerve cord. (B) Postembryonic cell division pattern (Walthall, 1995).

This research focuses on the two inhibitory classes of motor neurons, VD and DD. A key gene expressed in these neurons that regulates the expression of a battery of genes is *unc-30*. UNC-30 is the master control gene in the differentiation of type D mns, which are GABAergic (Jin et al., 1994). This gene belongs to the bicoid-like transcription factor family and is homologous to mammalian *pitx-1*, *2*, *3*, genes; known to be responsible for left-right symmetry. It is a homeobox transcription factor. UNC-30 directly regulates the expression of three genes responsible for the GABAergic fate. These include the enzyme Glutamic Acid Decarboxylase (*unc-25*), the two vesicular GABA transporters (*unc-46* and *unc-47*). It also directly regulates the expression of neuropeptide *flp-13* (Eastman et al., 1999, Cinar et al., 2005, Shan et al., 2005).

Bioinformatics analysis of the promoters of the direct downstream targets of UNC-30 (*unc-25*, *unc-46*, *unc-47* and *flp-13*) revealed, UNC-30 binds to the promoters at TAATCH (H=T/C/A) (Cinar et al., 2005). Transcriptional reporter analysis using mutations in *unc-30(e191)*, show no expression of *punc-25::gfp*, *punc-47::gfp* or *pflp-13::gfp* in the D type mns in these animals. When UNC-30 is mis-expressed in the sensory neurons in the head, UNC-30 causes ectopic expression of *unc-25*, *unc-46* and *unc-47* in those neurons (Eastman et al., 1999). Hence, UNC-30 is both necessary and sufficient to induce expression of *unc-25*, *unc-46* and *unc-47* in the D mns.

A neuropeptide gene, *flp-13* is directly regulated by UNC-30. *pflp-13::gfp* is expressed only in the DD because in the VDs, UNC-55 turns it off (Shan et al., 2005). When *unc-30* is taken away, little to no expression of *pflp-13::gfp* is seen in the VNC. Bioinformatics analysis revealed a putative UNC-30 binding site TAATCC is located 154 bp upstream of the +1 TSS in the *flp-13* promoter. When this site was mutated, the expression of *pflp-13::gfp* was completely lost in the DDs (Figure 1.5) (Shan et al., 2005).

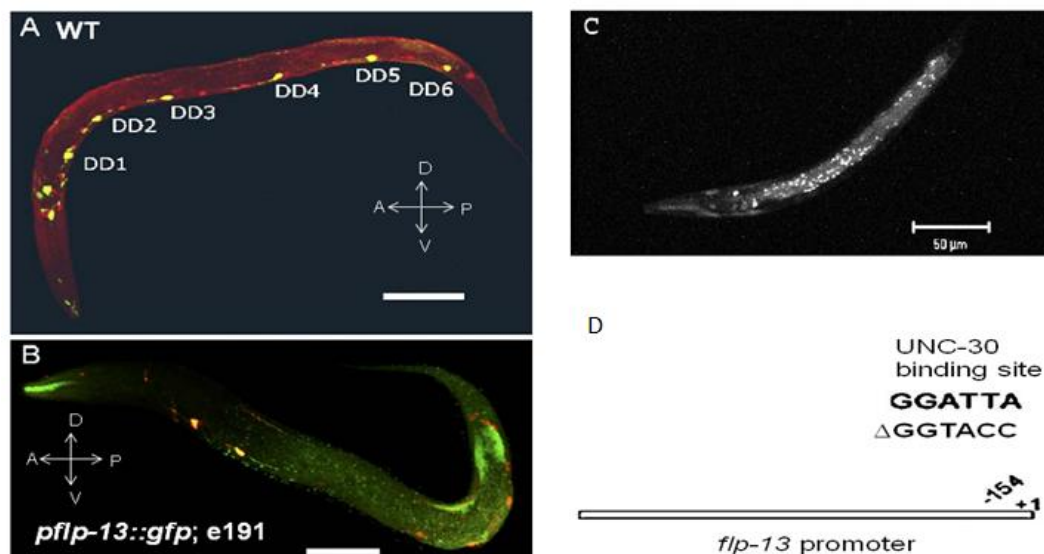

Figure 1.5 : (A, B) Change in expression of *pflp-13::gfp* reporter in wt and *unc-30* (*e191*) background. (C, D) Expression when the UNC-30 binding site has been mutated (Shan et al., 2005).

Transcription factors were known to act as molecular switches. Terminal selector gene is a relatively new term given to transcription factors. Hobert in 2008 redefined the term terminal selector. The criterion for a terminal selector gene is: it is required to specify specific identity to a class of cells. It does so by directly regulating the expression of terminally differentiated genes. Secondly, it is expressed throughout the life of a cell. Thirdly, it is required to maintain the differentiated state. Loss of such a gene, results in loss of specific identity but the pan neuronal features along with the gross morphology and position remain intact (Hobert, 2008). UNC-30 fulfills this criterion of being a terminal selector gene. It is expressed throughout the life of the D mns where it regulates the expression of *unc-25*, *unc-47* and *unc-49* which specify identity to the GABAergic mns (Jin et al., 1994). Loss of UNC-30 does not alter the gross morphology and position of the neurons to a large extent. These neurons show defects in axonal path finding and connections with synapse (Jin et al., 1994).

Neuropeptide gene, *flp-13* and transcription factor, *unc-30* are expressed in a small subset of mns, namely the DDs and DDs and VDs respectively. But other genes such as neuro-peptide, *flp-11*,

guidance gene, *unc-5* and a cytoskeletal motor gene, *unc-104* are expressed in multiple classes of mns. FLP-11 is a FMRamide like peptide (FLP) expressed in three distinct classes of motor neurons, namely the embryonic DA and DDs and post embryonic VD. UNC-5 is a trans-membrane protein in the immunoglobulin super gene family is involved in process guidance from the ventral to the dorsal nerve cord and is expressed in five of the eight classes of motor neurons: DA, DB, DD, VD and ASs. The last gene *unc-104*, a kinesin motor protein required for anterograde transport of cargo and is expressed in all motor neurons located in the VNC (WS230).

The central questions driving this research are: how are gene such as *unc-5*, *flp-11* and *unc-104* that are expressed in multiple classes of mns regulated? Are they regulated in a class specific manner, where terminal selector specific for that class, regulates their expression in that specific class of mns? Or are there common transcription factor(s) responsible for the regulation of these genes in all the mn classes? One hypothesis is that, UNC-30 is necessary for the specific expression of these reporter genes, only in the D mns. An alternate hypothesis would be that a non-class specific transcription factor(s) is necessary for the expression of these genes in multiple classes of mns.

Genes such as *unc-5* and *unc-104* in addition to UNC-30 are also conserved through evolution both by homology and function. There are three different isoforms of UNC-5 present in humans, UNC-5A, UNC-5B and UNC-5C. These are transmembrane proteins that guide growing axon extensions and cell migration during development. UNC-104, on the other hand is anterograde motor protein required for transport of membraneous molecules across the microtubules. The protein KIF-1A represents the human homolog of UNC-104/KIN-3. Neuropeptides and their receptors are also conserved. In this study, using a combination of a bioinformatics and microscopic approaches, the regulation of these well conserved gene reporters in the D mns has been studied.

In our study we conclude that UNC-30 is necessary for the expression of the three reporters: *pflp-11::gfp*, *punc-5::gfp* and *punc-104::gfp* only in the D mns. The role of UNC-30 in regulation of *punc-*

104::gfp seems to be also influence by other factors in addition to UNC-30. We conclude that genes in these multiple classes are regulated in a class specific manner. This study shows that ALR-1 may act as a cofactor in directly regulating the expression of *punc-104::gfp* in both the D mns and is involved in the regulation of *punc-5::gfp* and *punc-104::gfp* in the cholinergic mns.

2 MATERIALS AND METHODS

2.1 *C. elegans* worm maintenance, reporter strains, phenotype and genetics

Wild type and transgenic *C. elegans* were grown and maintained at 22°C (Brenner, 1974) on a lawn of OP50 *Escherichia coli* seeded on NGM. Transgenic worms with green fluorescent protein (GFP) were obtained from Caenorhabditis Genetics Center. These were introduced into desired mutant backgrounds as follows. In each step 5-6 males were allowed to mate with 2 L4/ young adult hermaphrodites. Transgenic males obtained by crossing homozygous transgenic worms with N2 bristol strain or high incidence of males (*him-5*) strains were mated with hermaphrodite worms of the desired mutant background. Transgenic worms were selected by the presence of GFP under a fluorescence microscope and the presence of the mutant phenotype in the subsequent steps. This was done for each reporter construct mentioned in Table 2.1.

Mutations included *unc-30 (e191)*, *unc-30(ok613)* and *alr-1 (oy42)*. *unc-30 (e191)* is a single base pair substitution from C to G in the first exon leading to the formation of a premature stop codon. *unc-30 (ok613)* is a deletion in the homeobox domain. *unc-30* animals are uncoordinated showing shrinker phenotype when touched on the head (Brenner, 1974). The mutation *alr-1 (oy42)* includes a rearrangement and deletion of the *alr-1* as well as its flanking region making it a null allele (Melkman and Sengupta, 2005). *alr-1* animals showed a touch insensitive phenotype that was highly variable. Touch insensitivity was measured based on if each animal moved if it was gently touched 10 times alternately on the head and the tail (Chalfie and Sulston, 1981). It varied ranging from some that were indistinguishable from wild type (responsive 7-8 times of 10 touches) as opposed to completely touch insensitive (responsive to 1-2 touches of 10 touches) (Topalidou et al., 2011).

Table 2.1: Reporter strains

Reporter	Locomotion Phenotype	GFP expressed in
<i>pflp-11::gfp</i>	Wild type	DA, DD, VD
<i>punc-5::gfp</i>	Wild type	DA, DB, DD, VD, AS
<i>punc-104::gfp</i>	Wild type	All mns in VNC
<i>punc-129::gfp</i>	Wild type	DA, DB
<i>punc-25::gfp</i>	Wild type	DD, VD
<i>pflp-11::gfp; unc-30 (e191)</i>	Shrinker	-
<i>punc-5::gfp; unc-30 (e191)</i>	Shrinker	DA, DB, AS
<i>punc-104::gfp; unc-30 (e191)</i>	Shrinker	All except D mns
<i>punc-25::gfp; unc-30 (e191)</i>	Shrinker	-
<i>pflp-11::gfp; unc-30 (ok613)</i>	Mild shrinker	-
<i>punc-5::gfp; unc-30 (ok613)</i>	Mild shrinker	DA, DB, AS
<i>punc-104::gfp; unc-30 (ok613)</i>	Mild shrinker	All except D mns
<i>punc-25::gfp; unc-30 (ok613)</i>	Mild shrinker	-
<i>pflp-11::gfp; alr-1(oy42)</i>	Moderately touch insensitive	DD, VD
<i>punc-5::gfp; alr-1(oy42)</i>	Moderately touch insensitive	DD, VD
<i>punc-104::gfp; alr-1 (oy42)</i>	Moderately touch insensitive	DD, VD
<i>pflp-11::gfp; unc-30(e191); alr-1(oy42)</i>	Mild shinker and moderately touch insensitive	-
<i>punc-5::gfp; unc-30(e191); alr-1(oy42)</i>	Mild shinker and moderately touch insensitive	-
<i>punc-104::gfp; unc-30(e191); alr-1(oy42)</i>	Mild shinker and moderately touch insensitive	All except DD, VD, DA, DB, AS

2.2 Analysis of the transgenic worms

Transgenic worm preparations were mounted on 4 % agar pad glass slides containing 1 mM Sodium azide for immobilization and viewed under the Zeiss LSM 500 Confocal Microscope. The image stacks were collected using the Zeiss 510 software (version 2.8) and hardware. Z-stacks were made analyzed and collapsed onto a single plane to make a projection for presentation. Images were exported to Adobe Photoshop for final modifications.

2.3 Intensity Measures and Statistical analysis

The position of each motor neuron on the projection was compared to the previously mapped positions to annotate each motor neuron (Sulston et al., 1983, McIntire et al., 1997) . In addition to expression in the motor neurons, all of the reporters were expressed in neurons in either the head or tail ganglia. This expression was independent of *unc-30* and served as fiducial markers in allowing us to measuring relative changes in intensity. Intensity measures were made for each worm as follows: the intensity of a single head neuron in the anterior ganglion was normalized to the highest intensity by changing the brightness and the contrast settings. The intensity of each neuron was then measured and the change in intensity with respect to the head neuron was calculated. The average change in intensity of a particular neuron was calculated and compared to the average change in intensity of the same neuron in the wild type background. This was plotted on graph. The significance was calculated using Student's t-test (* $p < 0.05$, ** $p < 0.005$, *** $p < 0.001$) (Price, 2011).

2.4 Bioinformatics analysis

2.4.1 Sequence Isolation and inter-species conservation

The upstream regulatory regions (2000 bp from the +1 TSS) as well as the first exon and intron of the reporters were copied from WormBase (WS230). A comparative bioinformatics approach was used

which entailed the use of various softwares. Multiple Species Sequence Alignment (MUSSA) was used to isolate the evolutionary conserved regions within the upstream promoter of reporters copied from three different species of *Caenorhabditis* (*C. elegans*, *C. briggsae* and *C. remanei*) (<http://mussa.caltech.edu>). Using a standard window size of 30 nucleotides, each species was compared in an N way transitivity (all against all) to highlight these conserved regions. Only those windows that passed a certain selected threshold were shown as alignments. The threshold was selected so that vertical (mostly parallel lines) with lowest noise could be selected. This program had the advantage of determining conserved regions in both the same direction (+ strand) and the reverse complement (– strand). These were highlighted in red and blue color respectively (Figure 3.11) (Kuntz et al., 2008).

2.4.2 Transcription factor analysis

Putative transcription factor binding sites within these conserved regions were predicted using Transcription Element Search Site (TESS, (Schug, 2008)) and MatInspector program (Genomatix). Both programs scan the copied conserved upstream region for potential binding sites to generate a position weight matrices and compare it to the known transcription factor databases for hits. Transcription factors having p value <0.05 were selected. Similarly, transcription factors in *C. briggsae* and *C. remanei* were also analyzed. The common transcription factors in the three species were then selected. MatInspector uses a common transcription factor finder program that generates a list of transcription factors present in the three species. Using this program, we selected those transcription factors that were statistically significant in the binding capacity based on p-values.

Another program modENCODE, model Encyclopedia for DNA Elements (<http://www.modENCODE.org>; (Celniker et al., 2009)) was used. This predicts potential transcription factors binding to within 500 bps of the TSS using Chromatin Immunoprecipitation (ChIP) data (Gerstein

et al., 2010). The set of common transcription factors from these three programs provided the most likely candidate transcription factor that would be necessary for the regulation of the three reporter genes.

3 RESULTS

3.1 *unc-30* is the master control gene for the D type GABAergic mns

Three genes that are more broadly expressed in the VNC are the netrin receptor *unc-5*, the neuropeptide *flp-11* and the kinesin motor *unc-104*. To test for the role of UNC-30 in the transcriptional expression of these genes, a bioinformatics approach of phylogenetic footprinting was used to detect the potential UNC-30 binding sites. Bioinformatics was complemented with a microscopy approach to see whether the loss of *unc-30* had any effect on the change in GFP expression in the D type mns in the VNC.



Figure 3.1: Consensus binding site for UNC-30 (Cinar et al., 2005)

UNC-30 recognizes a six base pair consensus sequence TAATCC in the promoter of genes (Eastman et al., 1999, Shan et al., 2005). Computational predictions of UNC-30 target genes from microarray analysis data suggested that only the first five base pairs within the consensus binding site enriched the target binding (Figure 3.1)(Cinar et al., 2005). The sixth base pair could be either C, T or A. Using this approach each of the three reporters (netrin receptor, *punc-5::gfp*, neuropeptide, *pflp-11::gfp* and kinesin motor, *punc-104::gfp*) showed the presence of UNC-30 consensus elements in their promoters. Both alleles of *unc-30* (*e191* and *ok613*) were used to test the role of UNC-30 in the regulation of these reporters.

3.1.1 Positive control: *punc-25::gfp*

The *punc-25::gfp* reporter is expressed in all 26 GABAergic mns including the D mns. This reporter was selected as a positive control to determine the extent of the loss of UNC-30 (*e191* and *ok613*) on the expression pattern. The change of expression in the three reporters can be evaluated relative to the control expression.

3.1.1.1 Control: *punc-25::gfp*

Analysis with *punc-25::gfp* reporter showed six DDs in each of the twenty seven control animals at the L1 stage (**Figure 3.2 A**). In the L2 stage, *punc-25::gfp* expressed in the 13 VDJs in addition to the 6 DDs in each of the eleven animals analyzed (**Figure 3.3 A**). For our study, in the L2 stage, we restricted our analysis to the 4 DDs and the 9 VDJs located in the region between the retro-vesicular ganglion and the pre-anal ganglion. This was followed in each of the reporters that we analyzed.

3.1.1.2 *punc-25::gfp; unc-30 (e191)*

In *unc-30 (e191)* mutant backgrounds, *punc-25::gfp* expression was decreased substantially as compared to wild type. In the absence of *unc-30 (e191)*, the expression was completely lost in DD3-DD6 in twenty animals but only partially reduced in the other DD mns. The other eleven animals showed patterns more reminiscent of the wild-type. This set of nematodes was observed to be milder shrinkers than the other *e191* mutant animals, which could be the reason of the more wild type like expression pattern. Figure 3.2 B shows one such animal with a loss of expression in all DDs except DD1. Overall, the intensities were significantly reduced in all the DDs (Figure 3.2 D).

In the L2 stage, the expression of *punc-25::gfp; unc-30 (e191)* in the DDs was reduced as described for the L1 stage. Six out of the nine animals showed a complete loss of *punc-25::gfp* expression in the *e191* allele, whereas the others showed more variability (Figure 3.3 B, D). Additionally, the expression in the VDJs was completely lost in five of nine animals in the *e191* background. The others showed

occasional expression in some VD9s as seen in Figure 3.3 B. The loss in intensity was significant in each of the VD9s except for VD9 (Figure 3.3 E).

3.1.1.3 *punc-25::gfp; unc-30 (ok613)*

In the absence of *unc-30 (ok613)*, the loss of expression was more variable. Each of the twenty animals showed low expression in most DDs and a complete loss in others. DD5 lacked expression in almost all the worms. Figure 3.2C shows a loss of expression in the DD5-6 and a substantially lower expression in DD3-4. The expression in DD1-2 was similar to wild type. The intensities of DDs in the *ok613* background significantly reduced in each of the DDs (Figure 3.2D).

In the L2 stage, the expression in the DDs in *punc-25::gfp; unc-30 (ok613)* allele was also variable. Five of the sixteen animals showed a complete loss whereas partial losses were observed in the other eleven (Figure 3.3 C). The intensity decreased significantly for the DDs in both alleles of *unc-30* except for DD2 in the *ok613* allele, which was reduced but was not significant (Figure 3.3 D). In the VD9s, the expression was highly variable ranging from no expression to the complete complement of VD9s in the sixteen worms observed (Figure 3.3C). The intensity for these worms reduced but it was not significant (Figure 3.3 E).

Thus, this variability in expression was consistent in the control *punc-25::gfp*. Such expression could be due to a read-through of the stop codon in the case of *e191* or a requirement of a cofactor along with *unc-30* in the regulation of these genes in case of both alleles.

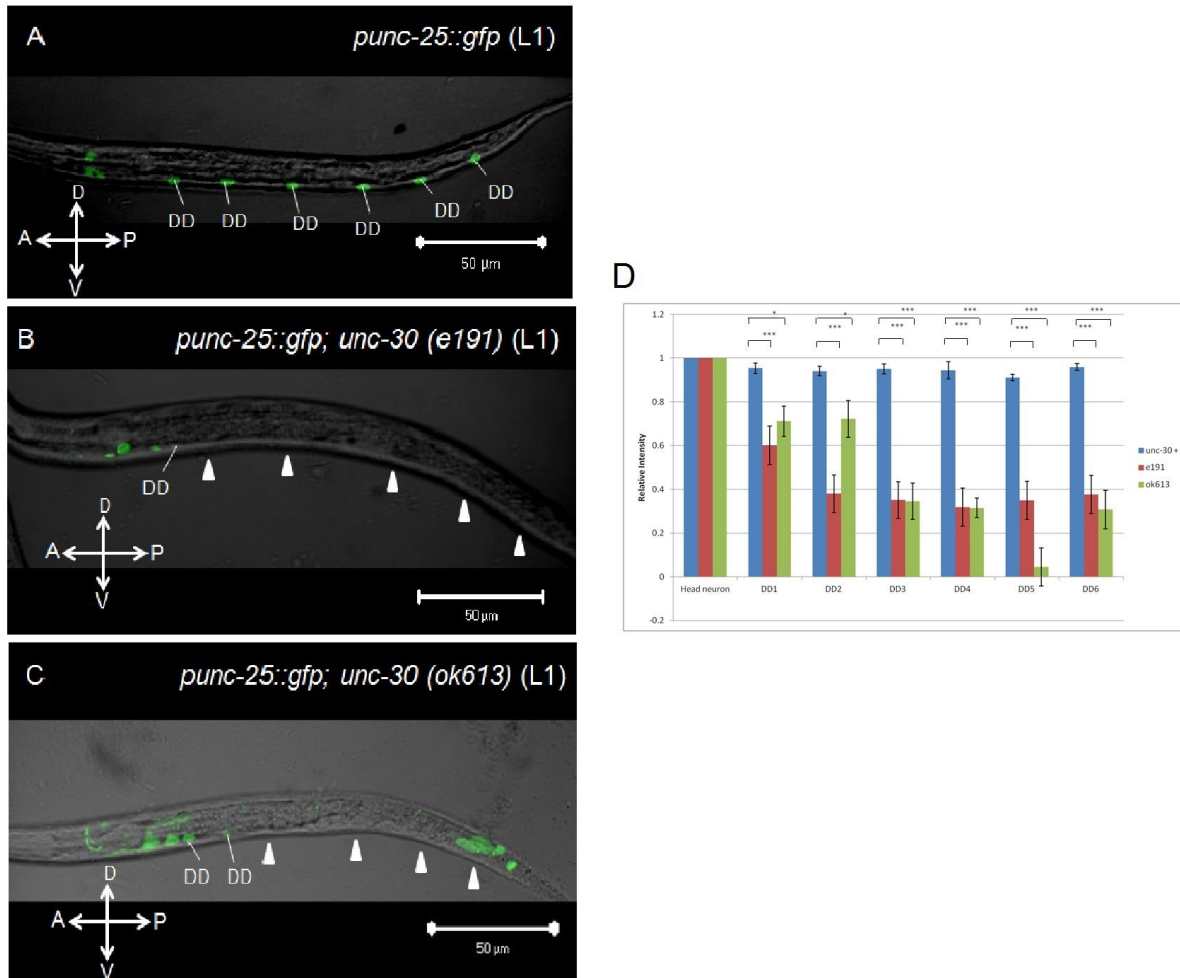

Figure 3.2 : (A, B, C) Comparison of expression in wild type *punc-25::gfp* and in both *unc-30* alleles (*e191* and *ok613*) in L1 stage. Left is anterior, right is posterior, dorsal is up and ventral is down in all the preps. Scale is 50 μm. (D) Graph represents the change in the intensity in the DDs at L1 stage with respect to the head neuron. n=27, 31 and 20 for wt, *e191* and *ok613* mutant backgrounds. Significance calculated using the student's t test where * p<0.05, ** p<0.005, *** p<0.001

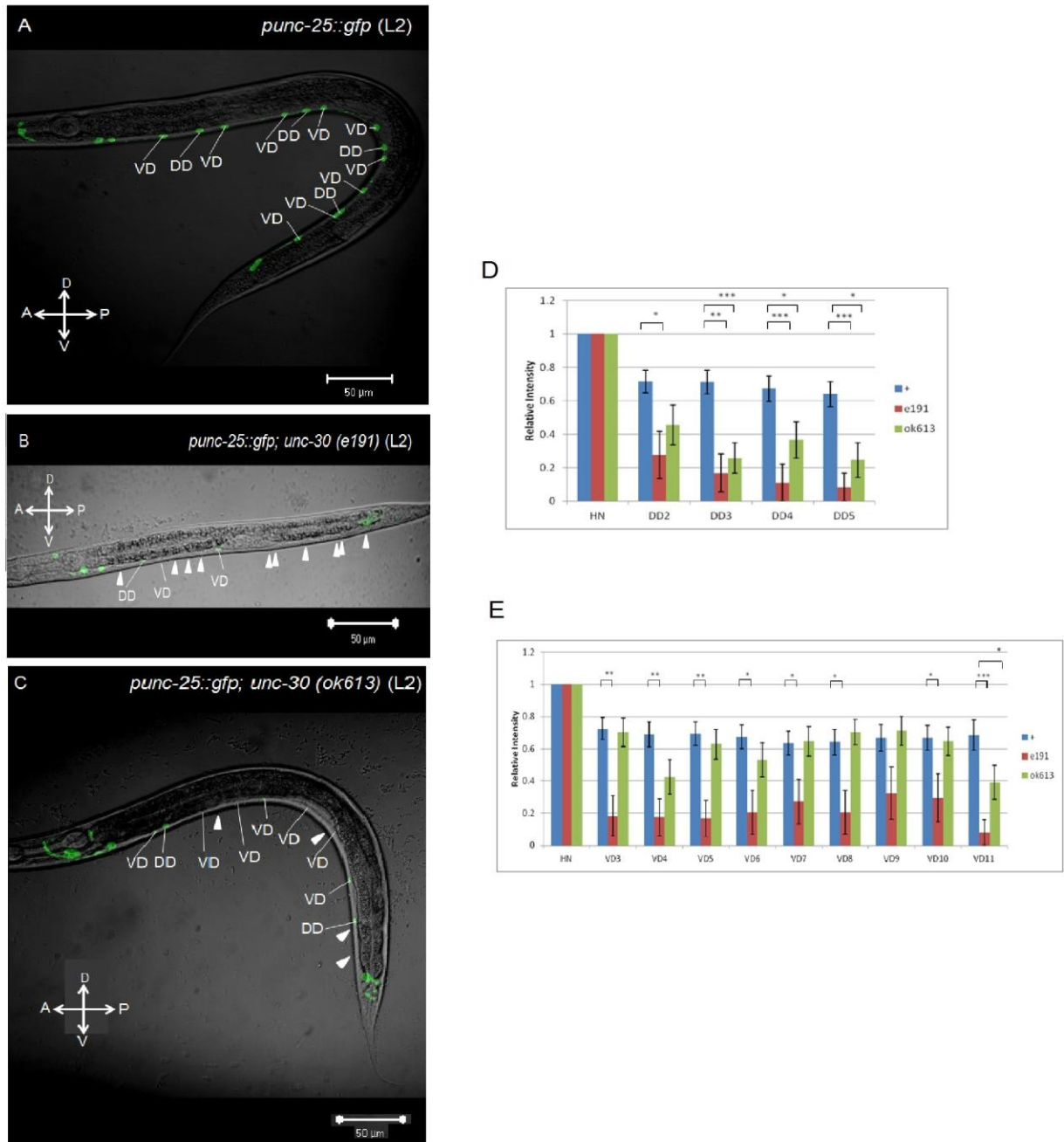

Figure 3.3 : (A, B, C) Comparison of expression in wild type *punc-25::gfp* and in both *unc-30* alleles (*e191* and *ok613*) in L2 stage. Left is anterior, right is posterior, dorsal is up and ventral is down in all the preps. Scale is 50 μ m. (D, E) Graphs represent the change in the intensity in the DDs and VD11 at L2 stage with respect to the head neuron. n=11, 9 and 16 for wt, *e191* and *ok613* mutant backgrounds. Significance calculated using the student's t test where * p<0.05, ** p<0.005, *** p<0.001.

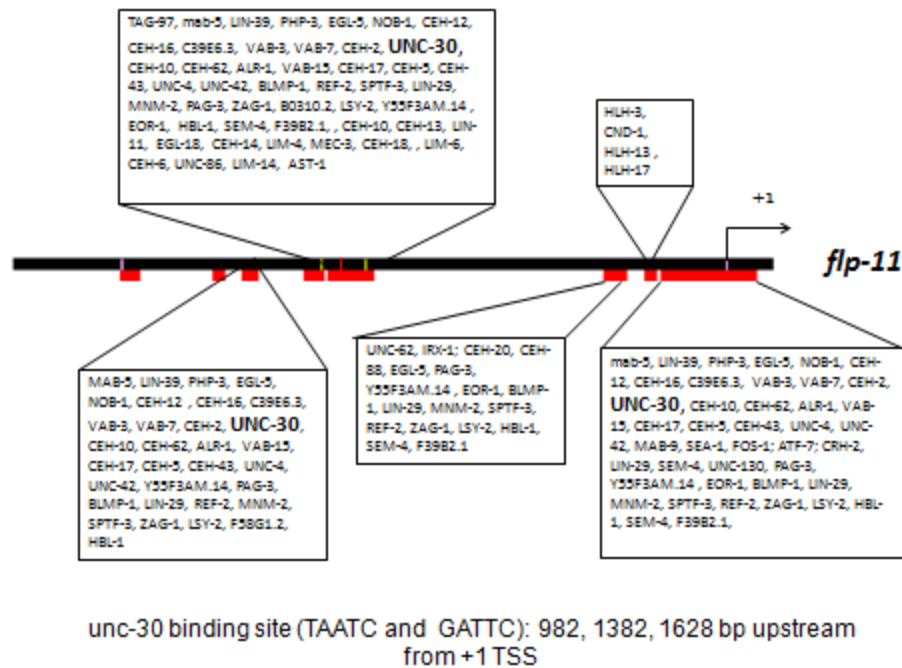

Figure 3.5 : Transcription factor binding site analysis on the *flp-11* gene promoter using TESS and MatInspector.

To confirm this, microscopic analysis was performed to examine the expression in of the *pflp11::gfp* reporter in the D motor neurons in the two *unc-30* mutant alleles.

3.1.2.1 Control: *pflp-11::gfp*

In the L1 stage, wild type *pflp-11::gfp* animals, four DDs were observed in each of the twenty four animals. No DAs were observed (Figure 3.6 A).

In the L2 stage, the expression of *pflp-11::gfp* is observed in the VDs in addition to the DDs. Nineteen *pflp-11::gfp* animals were observed. Just as in the L1 stage, the 4 DDs were seen in the body region of the animal. In addition, nine VDs were seen in each animal (Figure 3.7 A). DA3, 4, 5 was GFP positive in one animal whereas DA6 had GFP expression in two animals. In addition to DA6 an additional unidentified cell was seen in one animal in the VNC.

3.1.2.2 *pflp-11::gfp; unc-30 (e191)*

In the *unc-30 (e191)* mutant background, zero to six DDs were seen in the VNC (Figure 3.6 B). Each of the thirty nine animals observed, showed either a complete or partial loss of expression in most DDs. Hence intensity measures were performed to determine whether the partial loss was significant. The expression of *pflp-11::gfp* in the DD motor neurons showed a significant decrease in each of the motor neurons except DD1 (Figure 3.6 D).

But in the L2 stage, one to four DDs were observed in that region in *pflp-11::gfp; unc-30 (e191)*. Twenty-one animals in the *e191* were observed. Figure 3.7 B shows animals with two of the four DDs expressing *pflp-11::gfp* in *e191*. The expression was significantly reduced in most of the DDs in *unc-30 (e191)* allele (Figure 3.7 D). In addition to the DDs, zero to nine VDs were observed in the *e191* background (Figure 3.7 B). The pattern of expression was variable, however, a significant decrease in GFP intensity of the VDs in *e191* background was observed except the most posterior VD (Figure 3.7 E). In the *e191* background, two nematodes showed additional unidentified cell bodies. DA4 was GFP positive in one animal and ectopic expression was observed in a mid body region in the VNC in the other animal.

3.1.2.3 *pflp-11::gfp; unc-30 (ok613)*

The role of a deletion mutant *unc-30(ok613)* in the *pflp-11::gfp* reporter was tested to understand the variability of expression amongst the D mns. *pflp-11::gfp* in an *ok613* background yielded similar results as in the *e191* background. Each of the twenty three animals showed zero to five DDs in the VNC. The expression was significantly reduced in all DDs except DD1 (Figure 3.6 C, D).

In the L2 stage, there was a loss of GFP in one to four DDs in *pflp-11::gfp; ok613*. Twenty animals in the *unc-30 (ok613)* mutant backgrounds were analyzed. Expression in the DDs significantly reduced except in DD4 (Figure 3.7 D). Figure 3.7 C shows an animal with two of the 4 DDs in *ok613* background. One to nine VDs were seen in the *ok613* background (Figure 3.7 C). The expression in the VDs in the *unc-30 (ok613)* background was reduced, but the decrease was not significant. Few animals showed expres-

sion in the DAs. DA3 and DA4 were expressing GFP in one animal each. DA7 was GFP positive in two animals whereas DA5 and DA6 expressed GFP in 4 and 3 animals respectively. Along with DA5 and DA6, ectopic expression in one additional cell in the VNC was seen.

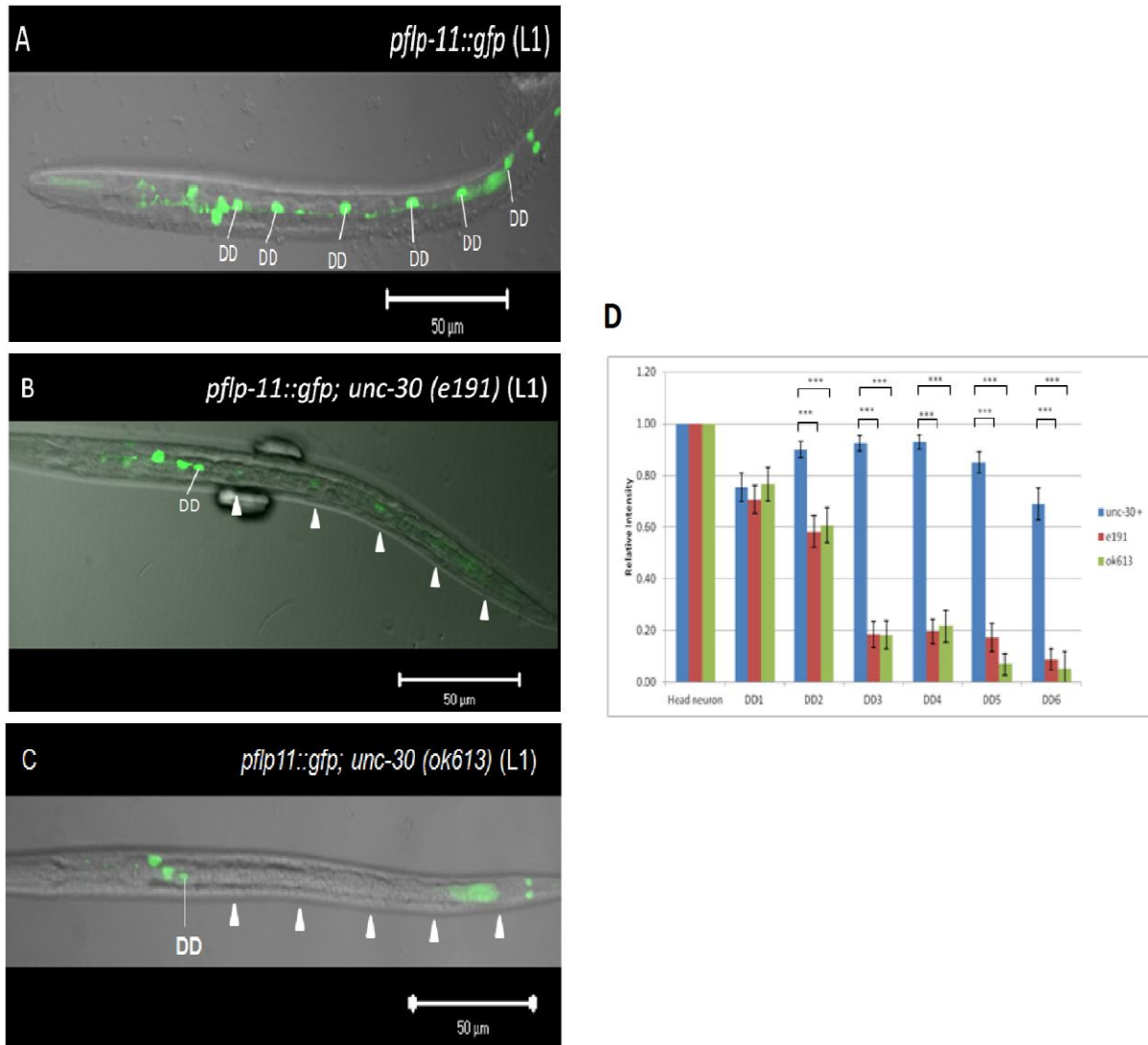

Figure 3.6 : (A, B, C) Change of expression in wild type *pflp-11::gfp* in two *unc-30* alleles (*e191* and *ok613*) in L1 stage. Both worms are placed ventral up. Scale is 50 μ m. (D) Graph represents the change in the intensity in the DDs at L1 stage with respect to the head neuron. n=24, 39 and 23 for wt, *e191* and *ok613* mutant backgrounds. Significance was calculated using the student's t test where * p<0.05, ** p<0.005, *** p<0.001.

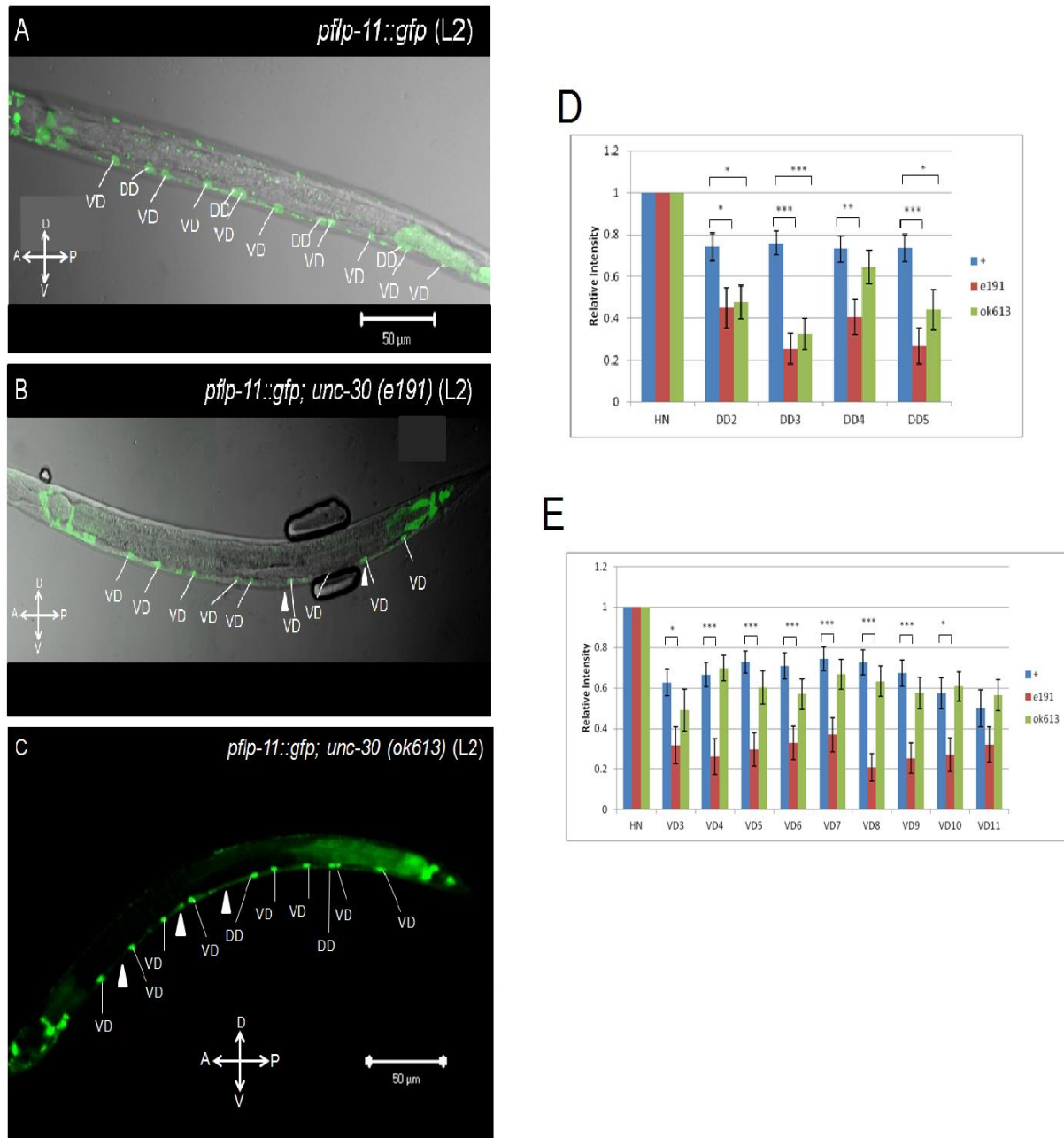

Figure 3.7 : (A, B, C) Comparison of expression in wild type *pflp-11::gfp* and in both *unc-30* alleles (*e191* and *ok613*) in the L2 stage. Left is anterior, and dorsal is up in all the preps. Scale is 50 μ m. (D, E) Graphs represent the change in the intensity in the DDs and VDs at L2 stage with respect to the head neuron. n=19, 21 and 20 for wt, *e191* and *ok613* mutant backgrounds. Significance calculated using the student's t test where * $p < 0.05$, ** $p < 0.005$, *** $p < 0.001$.

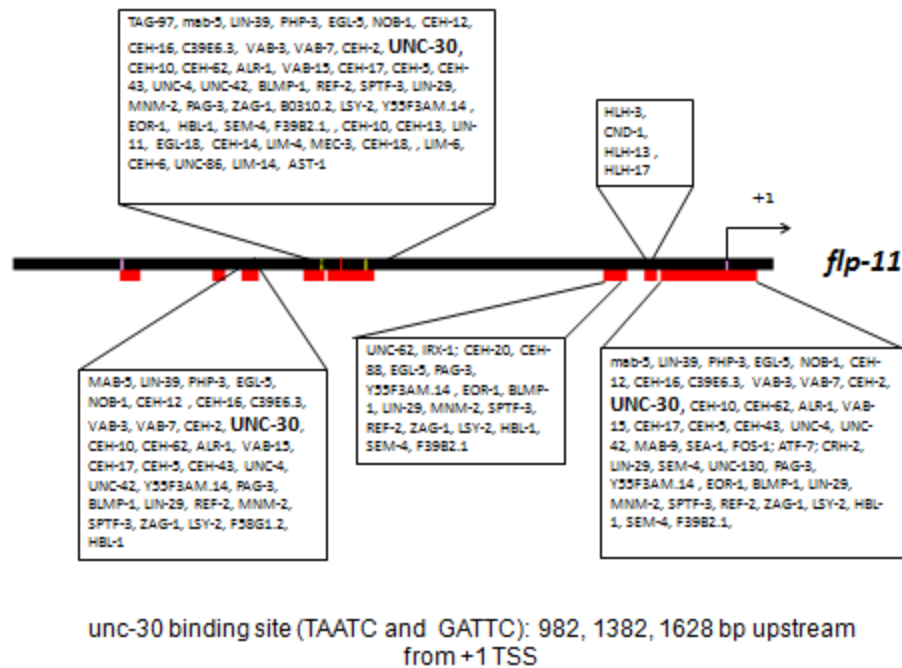

Figure 3.9 : Transcription factor binding site analysis on the *unc-5* promoter using TESS and MatInspector.

A microscopic analysis was performed on the *punc-5::gfp* promoter to test for changes of *punc-5::gfp* expression in the *unc-30* mutants.

3.1.3.1 Control: *punc-5::gfp*

Seventeen *punc-5::gfp* animals were observed. Each of the wild type animals showed *gfp* expression in the four DDs and also in six DAs and five DBs in the region between the retro-vesicular ganglia and the pre-anal ganglion (Figure 3.10 A).

In the L2 stage, *punc-5::gfp* expression was observed in four animals. These animals could not be projected onto a single Z plane due to the high background fluorescence but the analysis was done by counting the cell bodies in each case. Two animals showed expression in four DDs and nine VD. In addition to these thirteen cells, an additional cell was seen in each case. These cells could be AS7 and AS10

in either case based upon the position. The third animal expressed *gfp* in ten cells (DD2-3, DD5 and VD3-VD6, VD9-11). Expression was not seen in the mid body region due to auto fluorescence. The fourth animal was a younger animal and showed expression in all the VDs except VD4-5 which could not be observed because of the background and in DD2. The other DDs were also not seen.

3.1.3.2 *punc-5::gfp; unc-30(e191)*

In the L1 stage, in the *e191* mutant, five out of eighteen animals showed a complete loss of expression in the DD mns in the VNC. The loss of expression in the other DDs was variable. Figure 3.10 B shows one animal with loss of expression in all DDs except DD2. The change in intensity was significant for each DD (Figure 3.10 D).

In the L2 stage, *punc-5::gfp* in the *e191* background, the number of cell bodies as well as the intensity of expression was seen to be significantly reduced. Out of the four animals analyzed, one showed complete loss of expression, another showed nine neurons presumably two DDs (DD2 and DD5) and seven VDs (VD2-4, VD6-9), the third animal had expression in each of the nine VDs and DD2 and DD4 and an additional AS3 in the anterior. In the fourth animal, expression could be seen only in the region around and posterior to the gonadal primordium in the VD6-11 and in AS6, 8-11.

3.1.3.3 *punc-5::gfp; unc-30(ok613)*

In the *ok613* allele, eight of the nine animals showed a complete loss of expression in DD2-5 (Figure 3.10 C). Only one worm showed expression in the DD2 while losing expression in all other DDs. The intensities were significantly decreased in all of the DDs in the VNC in both the *unc-30* alleles (Figure 3.10D). There was no substantial change in the expression of the DAs and DBs as expected.

In the L2 stage, in *punc-5::gfp; unc-30 (ok613)*, more variable expression was observed. Only a few cells could be seen in each animal. Four animals showed the following expression pattern. The first showed expression only in the two posterior VDs, VD7 and VD8. The second animal showed expression

in DD3 and two VDs, VD6 and VD7. The third showed GFP expression in the posterior VD and AS pairs (VD 9-11 and AS 9-10). The expression in the ASs was brighter than the expression in the VDs. The last animal showed no expression in the VNC but expression was observed in the head.

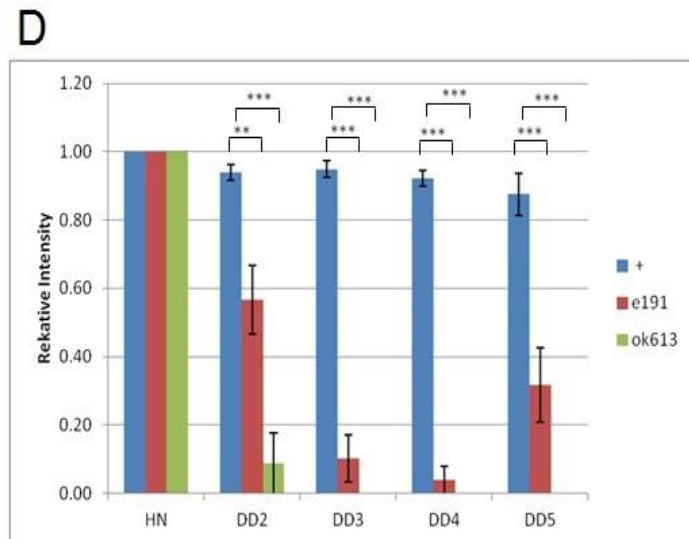
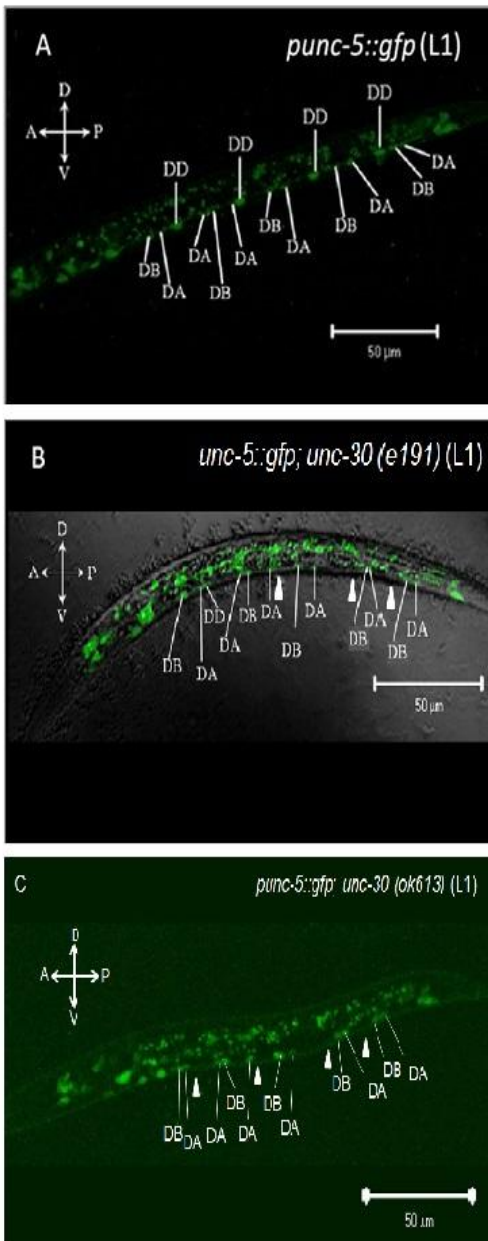

Figure 3.10: (A, B, C) Comparison of expression in wild type *punc-5::gfp* and in both *unc-30* alleles (*e191* and *ok613*) in L1 stage. Left is anterior, right is posterior, dorsal is up and ventral is down in all the preps. Scale is 50 μ m. (D) Graph represents the change in the intensity in the DDs at L1 stage with respect to the head neuron. n=17, 18 and 9 for wt, *e191* and *ok613* mutant backgrounds. Significance calculated using the student's t test where * p<0.05, ** p<0.005, *** p<0.001

3.1.4 Kinesin motor : *unc-104*

Promoter and first exon-intron analysis on the *unc-104* gene using bioinformatics, revealed four consensus UNC-30 binding sites 156, 172, 463, 1277 bp upstream from the +1 TSS (Figure 3.11). Additional analysis using the areas of conservation among *C. elegans*, *C. briggsae* and *C. remanei* (using MUSSA) did not yield an UNC-30 transcription factor binding sites (Figure 3.11 and Figure 3.12). Areas conserved within the first exon and introns were also considered as in the two other reporters.

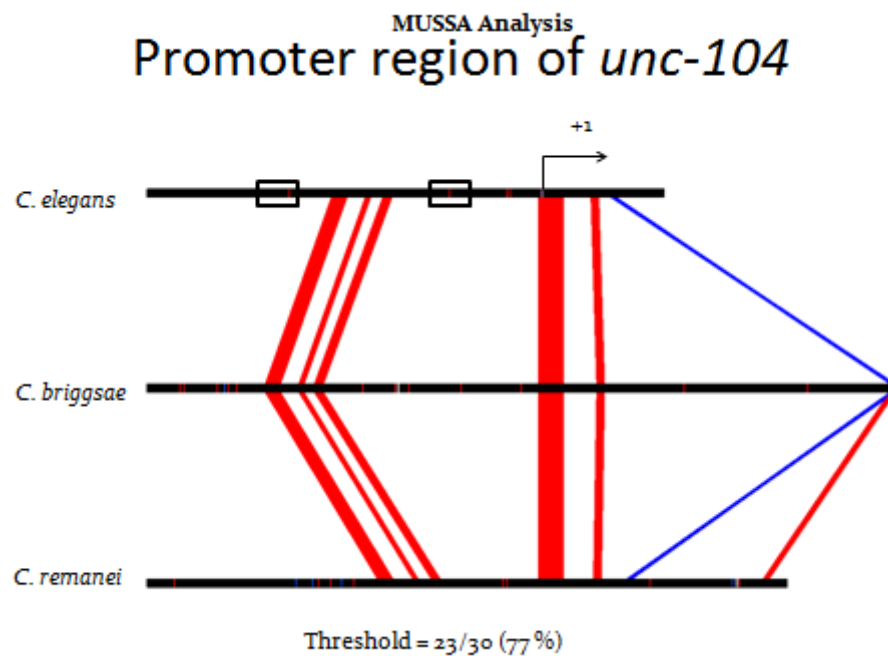
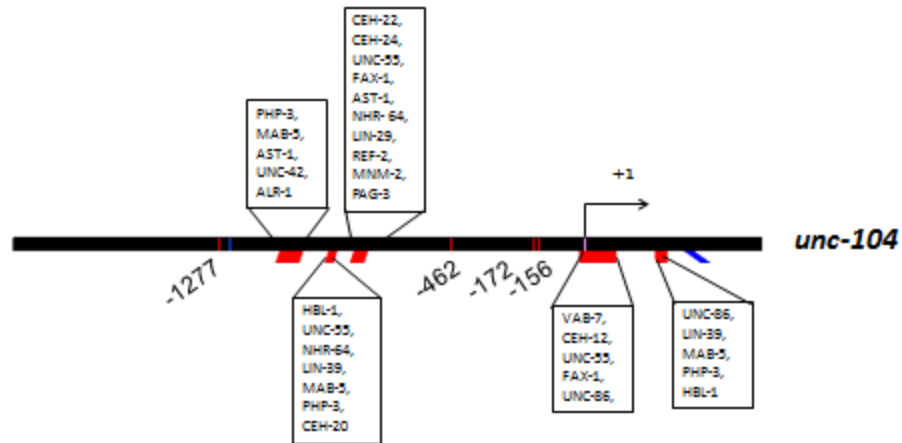

Figure 3.11 : Comparison of the *unc-104* gene promoter and the first exon and introns to isolate regions of conservation within *C. elegans*, *C. briggsae* and *C. remanei* using MUSSA. 2000 base pairs from the +1 TSS was used. Black bars indicate the DNA sequence; Red regions indicate the areas of conservation in the plus strand of the DNA while the blue region represents the alignment in the reverse complement strand. Black box indicates the location of the UNC-30 binding sites (TAATC) (in maroon) within these conserved areas using the consensus five base pair binding sites.



unc-30 binding site (TAATC and GATTA): 156, 172, 462, 1277 bp upstream from +1 TSS

Figure 3.12 : Comparison of the *unc-104* gene promoter and the first exon and introns to isolate regions of conservation within *C. elegans*, *C. briggsae* and *C. remanei* using MUSSA. 2000 base pairs from the +1 TSS were used.

Microscopic analysis was performed to analyze the effect of *unc-30* mutants on the expression of *punc-104::gfp* reporter.

3.1.4.1 Control: *punc-104::gfp*

In the L1 stage, in the wild type animals, expression was seen in fifteen cells: four DDs, six DAs and five DBs in each of the twenty one animals (Figure 3.13 A).

In the L2 stage, a more variable expression pattern was observed. Fourteen controls were analyzed. In six control animals, one to three DDs were absent and up to 7 VDs were missing (Figure 3.14 A). But in most animals cells corresponding to the positions of the ASs were observed. AS2 was on in 14 %, AS3 was on 36%, AS4, AS 8 and AS 10 were on 21% and AS5 was on 36% of the time.

3.1.4.2 *punc-104::gfp; unc-30 (e191)*

In L1 stage, *punc-104::gfp; unc-30 (e191)* mutant background, the DDs showed a reduction in the intensity of expression and the number of cells as compared to the wild type (Figure 3.13 B, D). Twenty worms were analyzed. DD2 lacked GFP expression 65% of the time whereas the other DDs failed to express GFP less than 25 % of the time. The expression in the cholinergic mns (DAs and DBs) was not affected.

In the L2 stage, in the sixteen animals in the *e191* background, zero to four DDs and zero to five VDs were missing in some preps. There was loss of intensity of expression in some of the D mns (Figure 3.14 B, C, D, E). Additional cells: ASs were also observed as in the wild type. AS 2 and AS5 were seen in 25%, AS4 and AS9 in 12.5%, AS8 in 62% and AS10 in 44% of preps observed. In addition to the ASs, one or two additional cells were observed along with AS10 in three worms.

3.1.4.3 *punc-104::gfp; unc-30 (ok613)*

In the *punc-104::gfp; ok613* strain nineteen animals were observed. Expression in each of the DDs for *punc-5::gfp; ok613* was significantly reduced but completely undetectable in only 15 % of the animals (Figure 3.13 C). DD2, DD3 and DD5 showed a significant decrease in intensity (Figure 3.13 D). Expression in DD4 decreased but was not seen to be significant. The expression in the cholinergic mns (DAs and DBs) was not affected.

In the *ok613* mutant background, in the L2 stage, eight animals were observed. Most worms showed all D mns but in some showed all D mns but in some cases a couple of DDs and one to three VDs were missing (Figure 3.14

Figure 3.14 C). In addition to these one to five extra cells were identified as ASs. AS3 and AS 5 and AS8 were on 38% of the times, AS 4 in 50% of the worms and AS10 in six of the eight worms analyzed. The intensity measures of the worms showed that the expression of *punc-104::gfp* was reduced in some but not all of the D mns. Some even showed an increase in intensity (Figure 3.14 D, E).

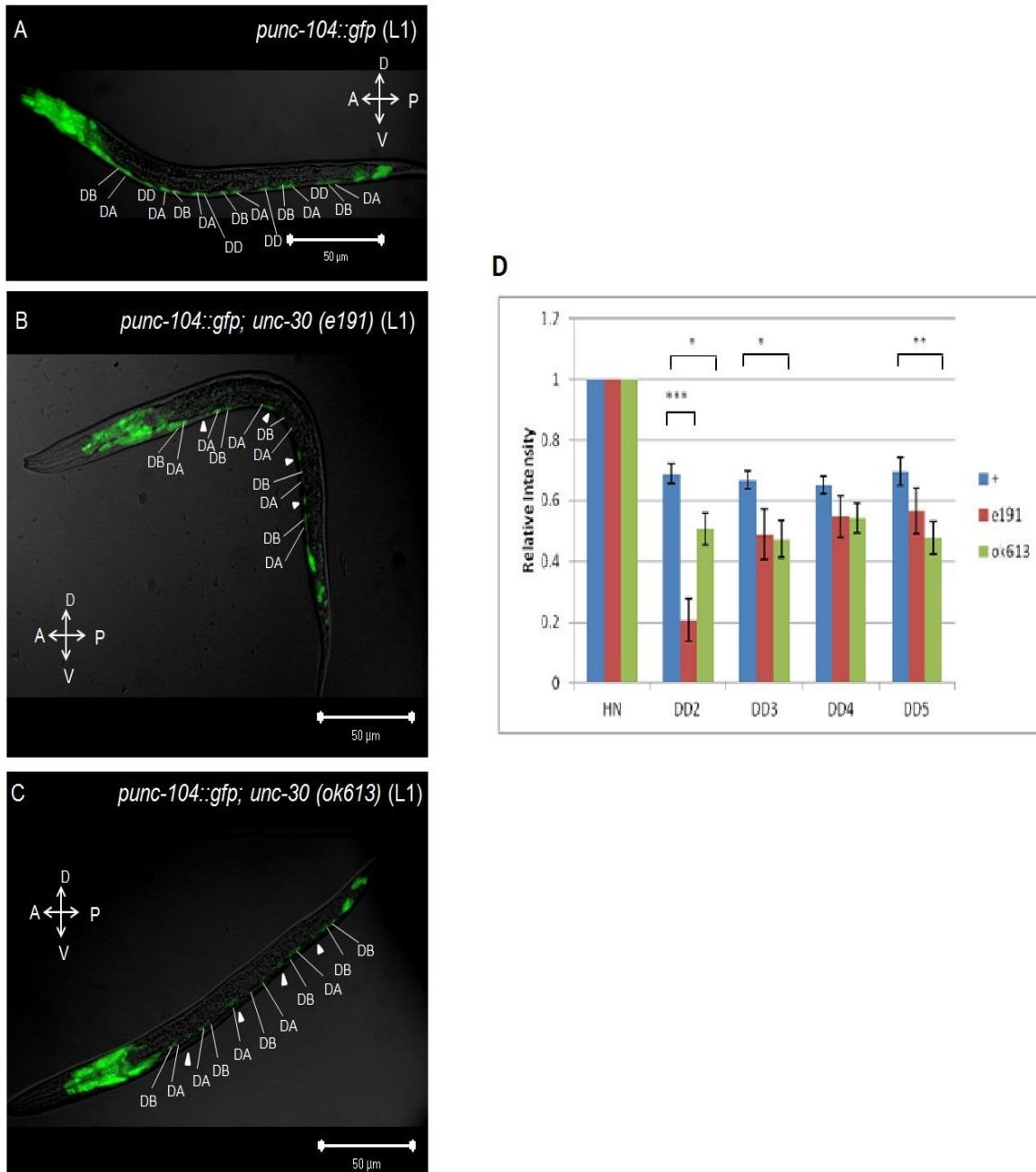

Figure 3.13 : (A, B, C) Comparison of expression in wild type *punc-104::gfp* and in both *unc-30* alleles (*e191* and *ok613*) in L1 stage. Left is anterior, right is posterior, dorsal is up and ventral is down in all the preps. Scale is 50 μ m. (D) Graph represents the change in the intensity in the DDs at L1 stage with respect to the head neuron. n=21, 20 and 19 for wt, *e191* and *ok613* mutant backgrounds. Significance calculated using the student's t test where * $p < 0.05$, ** $p < 0.005$, *** $p < 0.001$.

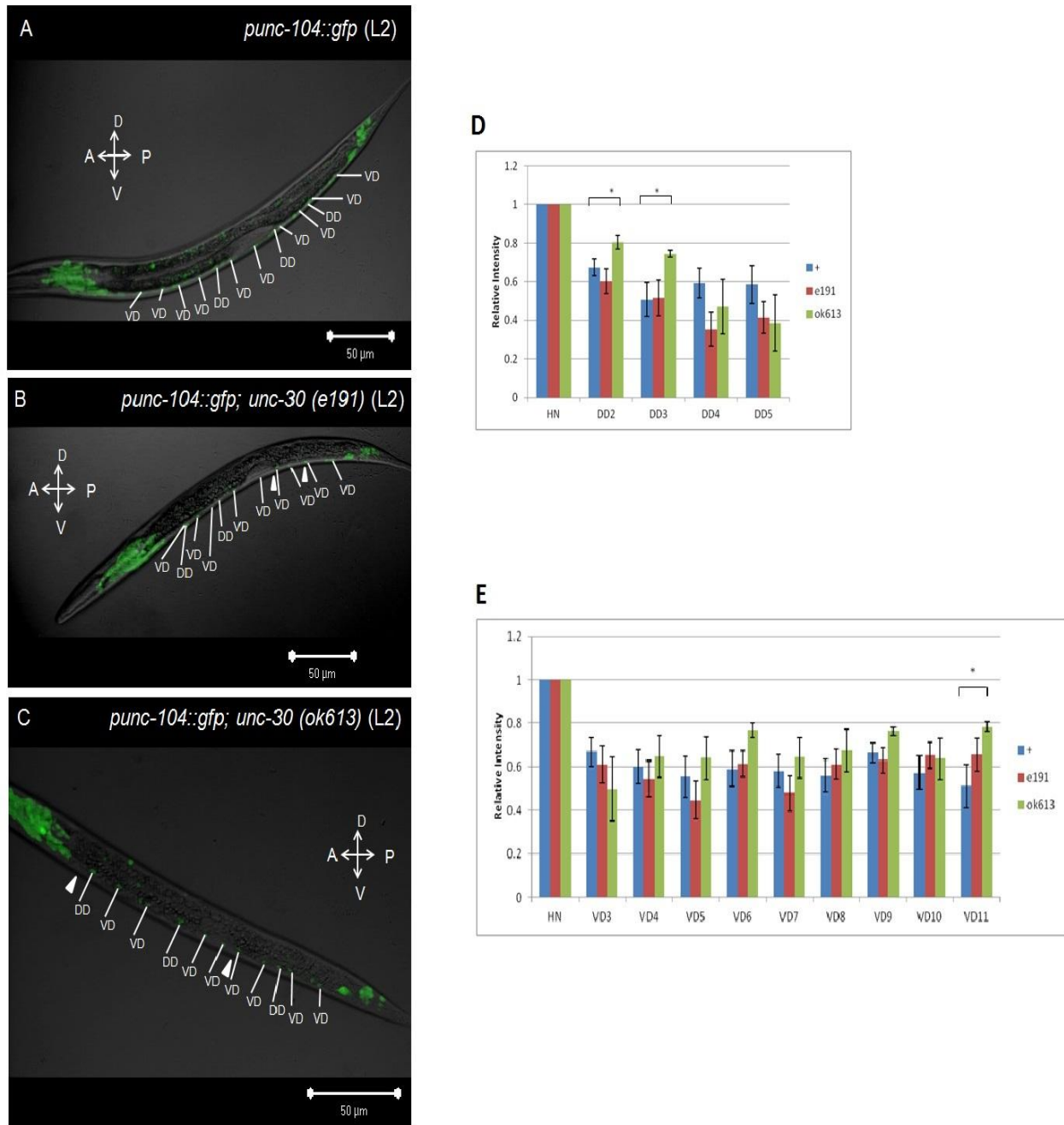

Figure 3.14 : (A, B, C) Comparison of expression in wild type *punc-104::gfp* and in both *unc-30* alleles (*e191* and *ok613*) in L2 stage. Left is anterior and dorsal is up in all the preps. Scale is 50 μ m. (D, E) Graph represents the intensity in the DDs at L2 stage with respect to the head neuron. $n=14, 16$ and 8 for wt, *e191* and *ok613* mutant backgrounds. Significance calculated using the student's t test where * $p<0.05$, ** $p<0.005$, *** $p<0.001$

This suggests that UNC-30 plays a lesser role in regulating *punc-104::gfp* reporter in the D mns than it does for the other two reporters. Other co-factors may influence the regulation of this reporter to a greater degree.

3.2 ALR-1 is necessary for the regulation of reporters in the cholinergic motor neurons

Bioinformatics analysis using modENCODE revealed a common transcription factor, ALR-1, binding to the upstream promoter region of each reporter (Table 3.1). ALR-1 is expressed in 24 of the 26 GABAergic cells (Melkman and Sengupta, 2005). ALR-1 regulates the expression of *punc-30::gfp* by binding to the promoter and also associates with some UNC-30 downstream targets, *unc-25*, *unc-46* and *unc-47* (Vermeirssen et al., 2007, Niu et al., 2011). ALR-1 ensures the proper differentiation of the D mns by facilitating the regulation of *unc-30* specific genes and downstream targets to certain specific classes of neuron thus decreasing variability (Topalidou et al., 2011). Therefore, ALR-1 was tested for its role in the regulation of these three reporters.

Table 3.1 : modENCODE analysis of the promoters of the three gene reporters.

<i>unc-5</i>	<i>flp-11</i>	<i>unc-104</i>
EOR-1_L3		EOR-1_L3
PHA-4_EMB_FEDL1_LEMB		
ALR-1_L2	ALR-1_L2	ALR-1_L2
MEP-1_EMB		MEP-1_emb
BLMP-1_L1		
HLH-1_EMB		
LIN-39_L3		LIN-39_L3
MAB-5_L3		MAB-5_L3
UNC-62_L1		UNC_62_L2_L3
ZAG-1_L1		ZAG_1_L1_L2_L3
EGL-5_L3		EGL_5_L3
		CEH_30_lemb
		CES_1_L1_L3_L4
		GEI_11_L3
		HLH_8_L3
		NHR_6v2_L2
		PES_1_L4
		SKN_1_L1

We tested the role of ALR-1 in the regulation of *punc-5::gfp*, *punc-104::gfp* and *pflp-11::gfp*.

3.2.1 *unc-5* gene reporter

3.2.1.1 Control: *punc-5::gfp*

In the L1 stage, seventeen *punc-5::gfp* animals were observed. Each of the wild type animals showed *gfp* expression in the four DDs and also in six DAs and five DBs. (Figure 3.15 A).

Four *punc-5::gfp* worms were analyzed in L2 and older animals. Two animals showed expression in four DDs and nine VDs. In addition to these thirteen cells, an additional cell was seen in each case. These cells could be AS7 and AS10 in either case based upon the position. The third animal expressed *gfp* in ten cells (DD2-3, DD5 and VD3-VD6, VD9-11). Expression was not seen in the mid body region due to auto fluorescence. The fourth animal was a younger animal and showed expression in all the VDs except VD4-5 which could not be observed because of the background and in DD2. The other DDs were also not seen.

3.2.1.2 *punc-5::gfp; alr-1 (oy42)*

In the *alr-1* mutant background, the *punc-5::gfp* reporter, showed a loss of expression in the DAs and DBs in the L1 stage and in the ASs in the L2 stage. In these animals the D mn expression remained. This pattern was observed in each of the twenty three *punc-5::gfp; alr-1* L1 animals observed (Figure 3.15 B).

In the L2 stage, thirteen worms in the *punc-5::gfp; alr-1* mutant backgrounds showed expression in the Dmns. No expression was seen in the AS mns. Figure 3.15 C shows the mn pattern observed in most of the *punc-5::gfp; alr-1* worms. Images of the controls could not be obtained due to high background fluorescence. These images were analyzed the cell bodies identified. Two *punc-5::gfp; alr-1* animals showed some variation in the pattern. One L2 worm showed eleven cell bodies. VD10 and 11 were

missing whereas in another adult worm, two additional cell bodies were seen. These were in the position of the AS2 and 3. This can be due to variability reported in *alr-1* mutants (Topalidou et al., 2011).

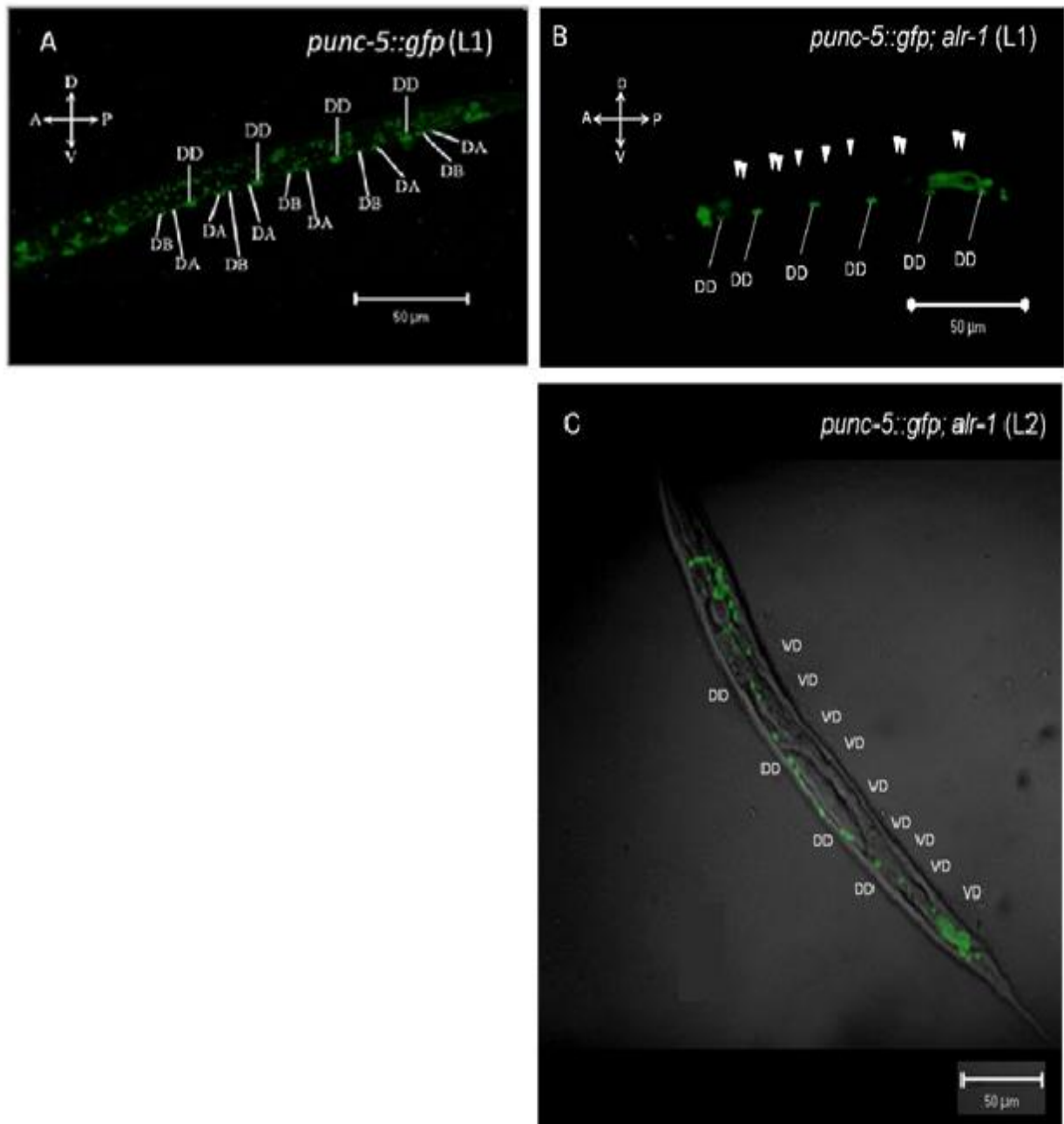

Figure 3.15 : (A, B) Comparison of expression in wild type *punc-5::gfp* and in *alr-1* (*oy42*) in L1 stage. $n=17$ and 23 for wt and *alr-1* mutant backgrounds respectively. (C) Expression of *punc-5::gfp* in the *alr-1* mutant background in the L2 stage. Left is anterior, right is posterior, dorsal is up and ventral is down in all the preps. Scale is 50 μm . $n=4$ and 13 for wt and *alr-1* mutant backgrounds respectively.

3.2.2 *unc-104* gene reporter

3.2.2.1 Control: *punc-104::gfp*

In the L1 stage, in the wild type animals, expression was seen in fifteen cells: four DDs, six DAs and five DBs in each of the twenty one animals (Figure 3.16 A).

In the L2 stage, a more variable expression pattern was observed. Fourteen controls were analyzed. In six control animals, one to three DDs were absent and up to seven VDs were missing. But in most animals cells corresponding to the positions of the ASs were observed. AS2 was on in 14 %, AS3 was on 36%, AS4, AS 8 and AS 10 were on 21% and AS5 was on 36% of the time (Figure 3.16 C).

3.2.2.2 *punc-104::gfp; alr-1 (oy42)*

In the *alr-1* mutant background, the *punc-104::gfp* reporter, showed a loss of expression in the DAs and DBs in the L1 stage and in the ASs in the L2 stage. In these animals the D mn expression remained. This pattern was observed in each of the twenty four *punc-104::gfp* L1 animals observed (Figure 3.16 B).

Each of the twenty three worms in the L2 stage in *punc-104::gfp, alr-1* mutant background showed the same expression as that of the control. One particular *punc-104::gfp; alr-1* worm shown in Figure 3.16 D was unusual as it showed a loss of expression in the D mns posterior to the gonadal primordium.

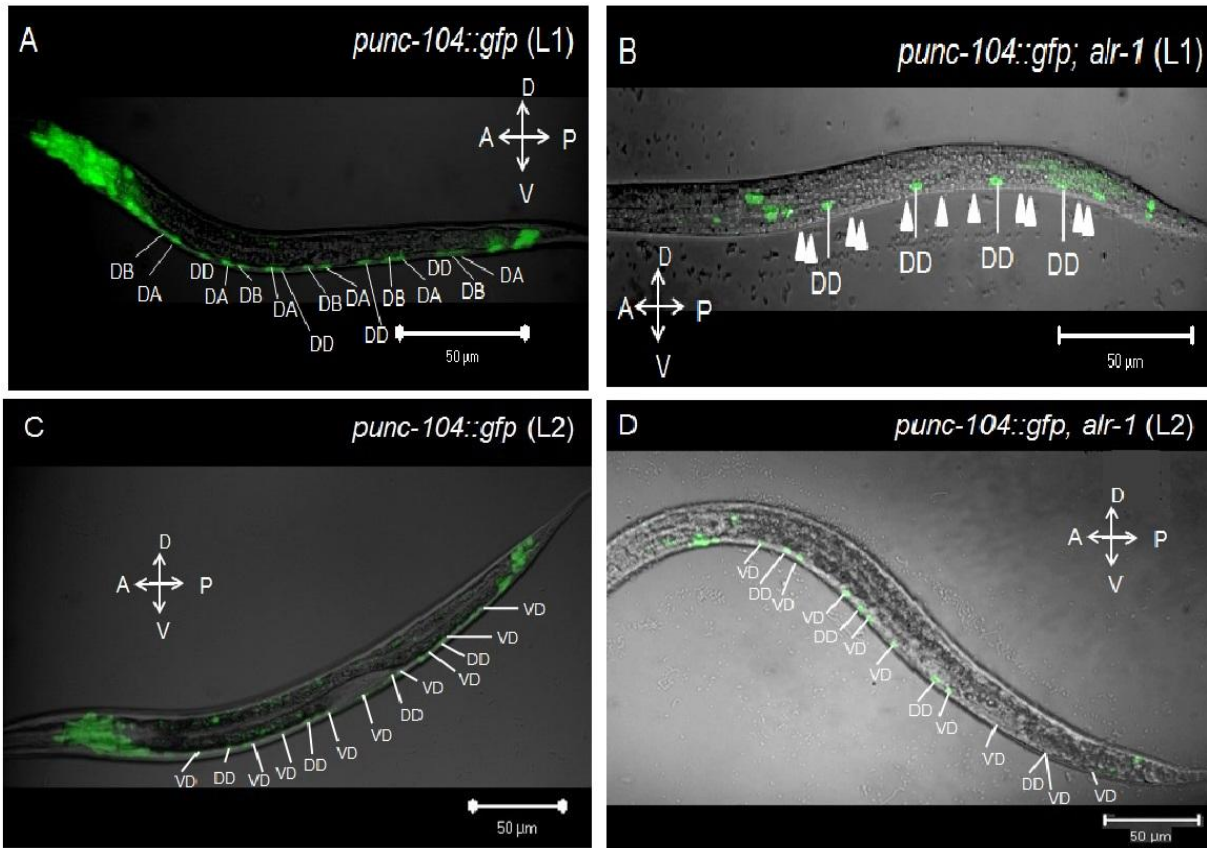

Figure 3.16 : (A, B) Comparison of expression in wild type *punc-104::gfp* and in *alr-1 (oy42)* in L1 stage. n=21 and 24 for wt and *alr-1* mutant backgrounds respectively. (C, D) Comparison of expression in wild type *pflp-11::gfp* and in *alr-1 (oy42)* in L2 stage. n=14 and 23 for wt and *alr-1* mutant backgrounds respectively. Left is anterior, right is posterior, dorsal is up and ventral is down in all the preps. Scale is 50 μm.

3.2.3 *flp-11* gene reporter

3.2.3.1 Control: *pflp-11::gfp*

In the L1 stage, wild type *pflp-11::gfp* animals, 6 DDs were observed in each of the twenty four animals. No DAs were observed (Figure 3.17A).

In the L2 stage, the expression of *pflp-11::gfp* is observed in the VDs in addition to the DDs. Nineteen *pflp-11::gfp* animals were observed. Just as in the L1 stage, the 4 DDs were seen in the body region of the animal and in addition to the nine VDs (Figure 3.17 C). DA3, 4, 5 was GFP positive in one

animal whereas DA6 had GFP expression in two animals. In addition to DA6, an additional unidentified cell was seen in one animal in the VNC.

3.2.3.2 *pflp-11::gfp; alr-1 (oy42)*

No change in expression was observed in the *pflp-11::gfp* in the L1stage. Each of the eleven *alr-1* mutants showed six DDmns (Figure 3.17 B).

In the L2 stage, each of the nine mutants showed thirteen cells representing the four DDs and the nine VDs between the retro-vesicular and the pre-anal ganglia. Figure 3.17 D shows one animal expressing *pflp-11::gfp* in four DDs and nine VDs. Three older animals showed an additional 1, 3 and 4 cells representing the DAs based upon their positions in the VNC. DA 2 was seen in one animal, DA3 and 4 were seen in two and DA6 was seen in three older animals. This is likely due to the variability in *alr-1* mutant phenotype (Topalidou et al., 2011).

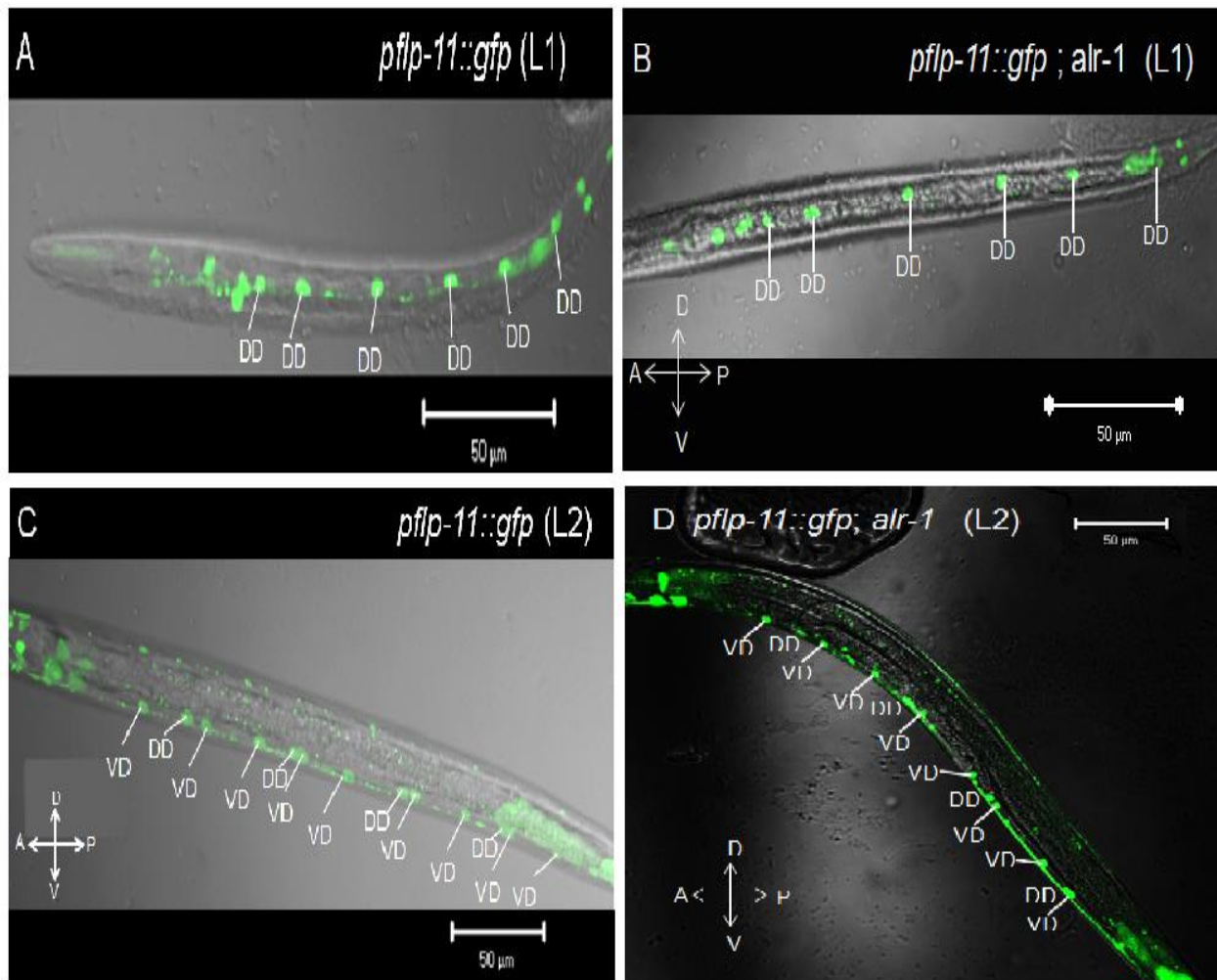

Figure 3.17 : (A, B) Comparison of expression in wild type *pflp-11::gfp* and in *alr-1* (*oy42*) in L1 stage. $n=24$ and 11 for wt and *alr-1* mutant backgrounds respectively. (C, D) Comparison of expression in wild type *pflp-11::gfp* and in *alr-1* (*oy42*) in L2 stage. $n=19$ and 12 for wt and *alr-1* mutant backgrounds respectively. Left is anterior, right is posterior, dorsal is up and ventral is down in all the preps. Scale is $50 \mu\text{m}$.

These results suggest that ALR-1 is necessary for the expression of *punc-5::gfp* and *punc-104::gfp* in the cholinergic motor neurons, DAs, DBs and postembryonic AS mns, whereas ALR-1 was not necessary for the expression in the Dmns (*pflp-11::gfp*; *punc-5::gfp*, *punc-104::gfp*).

3.3 *unc-30*, *alr-1* double mutants show loss of both GABAergic and cholinergic expression

The bioinformatics analysis suggest that *alr-1* and *unc-30* act together in the regulation of the reporters in the D mns. To test this possibility, the expression of the reporters was analyzed in the *unc-30(e191); alr-1(oy42)* double mutant backgrounds.

3.3.1 *pflp-11::gfp* reporter

3.3.1.1 Control *pflp-11::gfp*

In the L1 stage, wild type *pflp-11::gfp* animals, 6 DDs were observed in each of the twenty four animals. No DAs were observed (Figure 3.18 A).

In the L2 stage, the expression of *pflp-11::gfp* is observed in the VDs in addition to the DDs. Nineteen *pflp-11::gfp* animals were observed. Just as in the L1 stage, the 4 DDs were seen in the body region of the animal. In addition, nine VDs were also seen (Figure 3.19 A). DA3, 4, 5 was GFP positive in one animal whereas DA6 had GFP expression in two animals. In addition to DA6 an additional unidentified cell was seen in one animal in the VNC.

3.3.1.2 *pflp-11::gfp; unc-30 (e191)*

In the *unc-30 (e191)* mutant background, zero to six DDs were seen in the VNC in the L1 stage (Figure 3.18 B). Each of the thirty nine animals observed, showed either a complete or partial loss of expression in most DDs. Hence intensity measures were performed to determine whether the partial loss was significant. The expression of *pflp-11::gfp* in the DD motor neurons showed a significant decrease in each of the motor neurons except DD1 (Figure 3.18 D).

But in the L2 stage, one to four DDs were observed in that region in *pflp-11::gfp; unc-30 (e191)*. Twenty-one animals in the *e191* were observed. Figure 3.19B shows animals with two of the four DDs expressing *pflp-11::gfp* in *e191*. The expression was significantly reduced in most of the DDs in *unc-30*

(*e191*) allele (Figure 3.19 D). In addition to the DDs, zero to nine VDs were observed in the *e191* background (Figure 3.19B). The pattern of expression was variable, however, a significant decrease in GFP intensity of the VDs in *e191* background was observed except the most posterior VD (Figure 3.19 E). In the *e191* background, two nematodes showed additional unidentified cell bodies. DA4 was GFP positive in one animal and ectopic expression was observed in a mid body region in the VNC in the other animal.

3.3.1.3 *pflp-11::gfp; unc-30 (e191); alr-1 (oy42)*

In the double mutant *e191; alr-1*, the expression of the *pflp-11::gfp* reporter was significantly reduced in the DD mns as was *pflp-11::gfp* in the absence of *unc-30(e191)* at the L1 stage (Figure 3.18 B, C). Fourteen out of the twenty-five worms showed a complete loss of expression in DD3- DD6, DD1-2 were either intact or faint in some worms. In the remaining eleven worms, the DD mns showed variable but reduced expression. Figure 3.18 C shows one such worm showing complete loss of expression in DD3 and DD5 while a decrease in DD1-2, DD5 and DD6. The intensities showed a significant reduction in all DDs except DD1 suggesting that the expression in DD1 is controlled independently (Figure 3.18 D).

At the L2 stage, the expression of DDs was variable but significantly reduced similar to the L1 (Figure 3.19 D). Each of the sixteen worms showed a loss in either one or all the D mns. The expression in the newly born VDs was also variable. Figure 3.19 C shows one such worm that expresses *pflp-11::gfp* in only three VDs and two DDs in the VNC. The intensities in the VDs were also significantly reduced, as was described for the *unc-30 (e191)* allele (Figure 3.19 C, E).

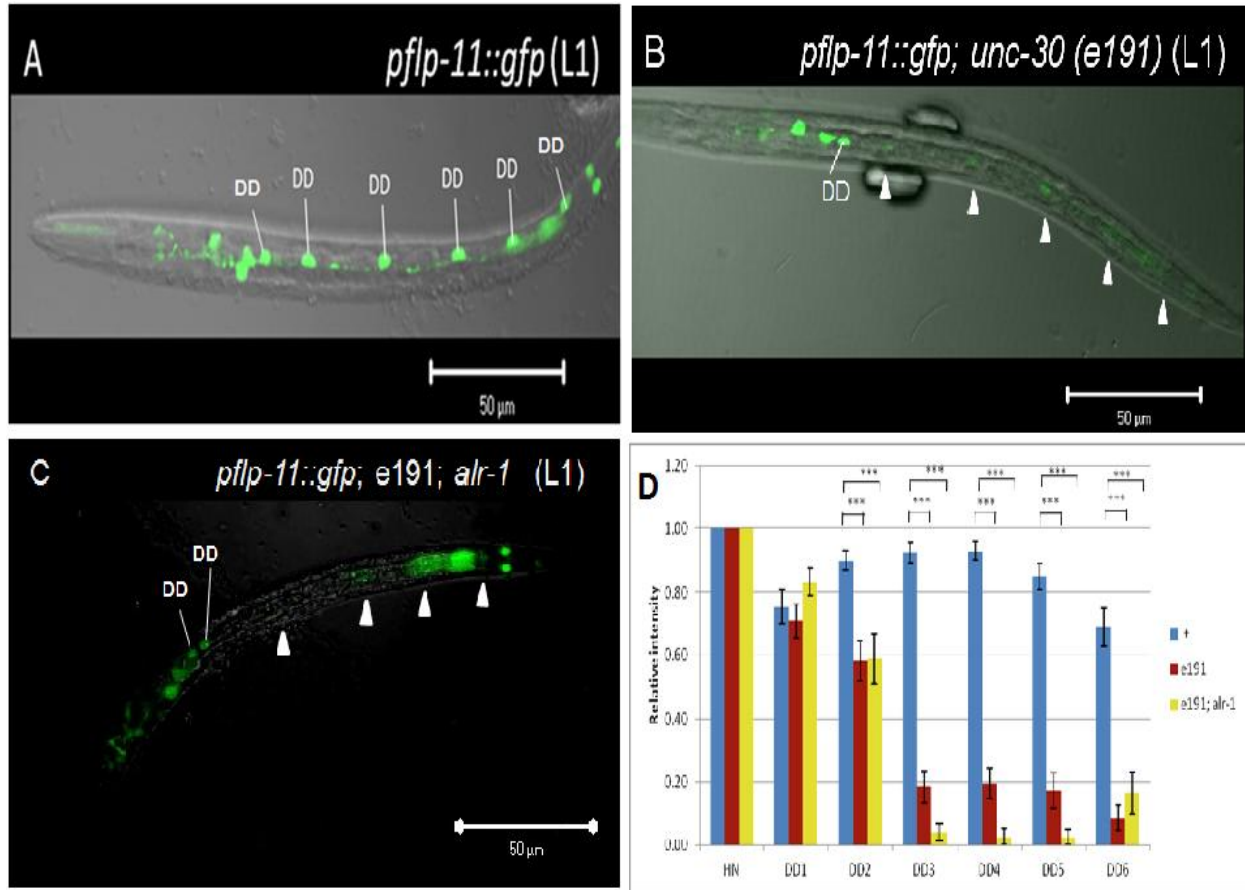

Figure 3.18: (A, B, C) Comparison of expression in wild type *pflp-11::gfp* and in the absence of *unc-30* (*e191*) and in the absence of both *unc-30* (*e191*) and *alr-1* in L1 stage. All worms are placed ventral up. Scale is 50 μ m. (D) Graph represents the change in the intensity in the DDs at L1 stage with respect to the head neuron. $n = 24, 40$ and 25 for wt, *e191* and *e191, alr-1* mutant backgrounds. Significance calculated using the student's t test where * $p < 0.05$, ** $p < 0.005$, *** $p < 0.001$.

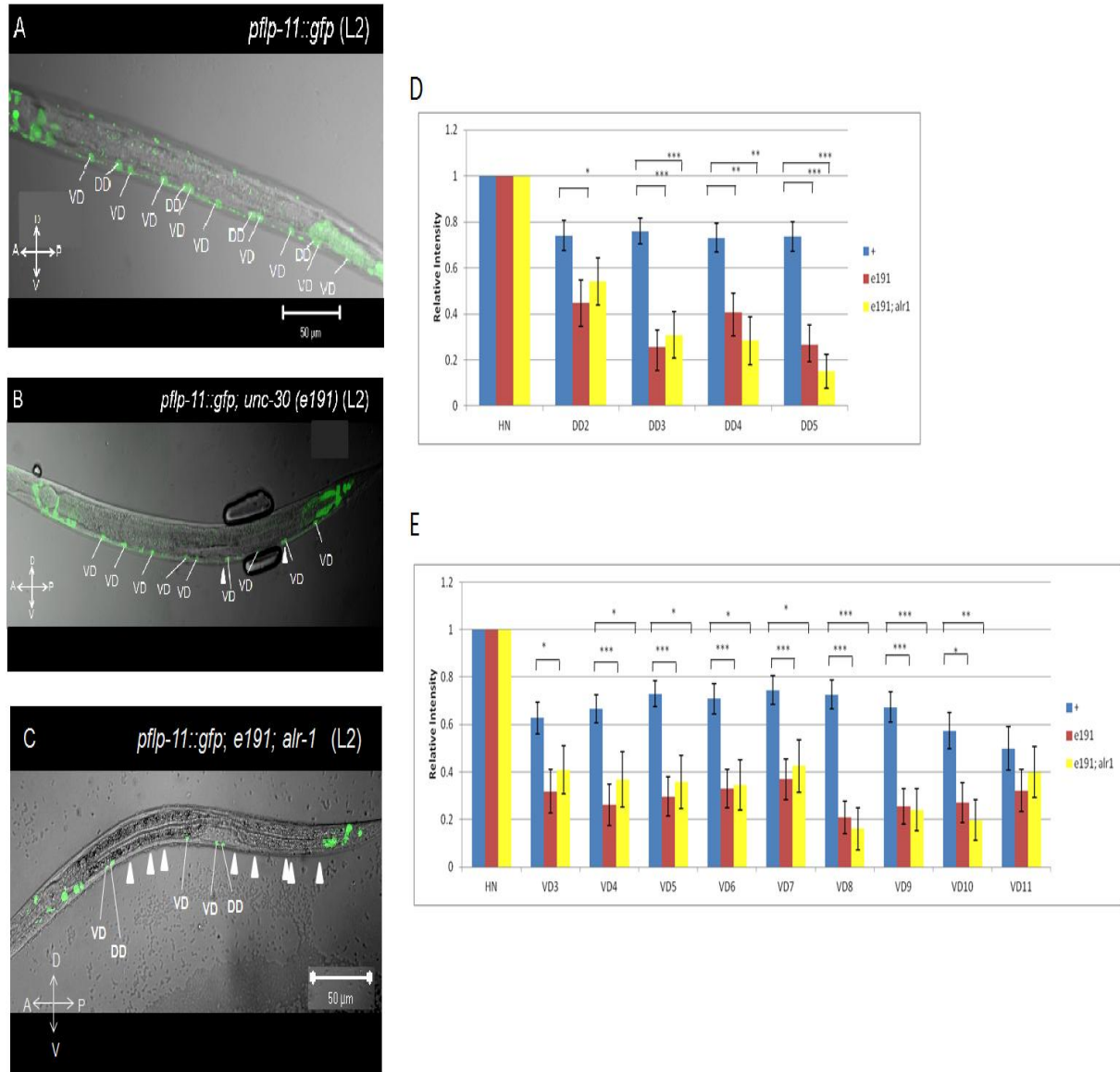

Figure 3.19 : (A, B, C) Comparison of expression in wild type *pflp-11::gfp*, *unc-30 (e191)* and double mutants, *unc-30 (e191); alr-1* in L2 stage. Left is anterior, right is posterior, dorsal is up and ventral is down in all the preps. Scale is 50 μ m. (D, E) Graphs represent the change in the intensity in the DDs and VDs at L2 stage with respect to the head neuron. n=19, 21 and 16 for wt, *e191* and *e191; alr-1* double mutant backgrounds. Significance calculated using the student's t test where * p<0.05, ** p<0.005, *** p<0.001.

3.3.2 *punc-5::gfp* reporter

3.3.2.1 Control *punc-5::gfp*

In the L1 stage, Seventeen *punc-5::gfp* animals were observed. Each of the wild type animals showed *gfp* expression in the four DDs and also in six DAs and five DBs (Figure 3.20 A).

Four *punc-5::gfp* worms were analyzed in L2 and older animals. Two animals showed expression in four DDs and nine VDs. In addition to these thirteen cells, an additional cell was seen in each case. These cells could be AS7 and AS10 in either case based upon the position. The third animal expressed *gfp* in ten cells (DD2-3, DD5 and VD3-VD6, VD9-11). Expression was not seen in the mid body region due to auto fluorescence. The fourth animal was a younger animal and showed expression in all the VDs except VD4-5 which could not be observed because of the background and in DD2. The other DDs were also not seen.

3.3.2.2 *punc-5::gfp; unc-30(e191)*

In the L1 stage, in the *e191* mutant, five out of eighteen animals showed a complete loss of expression in the DD mns in the VNC. The loss of expression in the other DDs was variable. Figure 3.20B shows one animal with loss of expression in all DDs except DD2. The loss in intensity was found to be significant in each of the DDs (Figure 3.20 D).

In the L2 stage, *punc-5::gfp* in the *e191* background, the number of cell bodies as well as the intensity of expression was seen to be significantly reduced. Out of the four animals analyzed, one showed complete loss of expression, another showed nine neurons presumably two DDs (DD2 and DD5) and seven VDs (VD2-4, VD6-9), the third animal had expression in each of the nine VDs and DD2 and DD4 and an additional AS3 in the anterior. In the fourth animal, expression could be seen only in the region around and posterior to the gonadal primordium in the VD6-11 and in AS6, 8-11.

3.3.2.3 *punc-5::gfp; unc-30 (e191); alr-1 (oy42)*

The *punc-5::gfp* reporter showed a decrease in expression in both the GABAergic and cholinergic mns in the L1 stage just as observed in the single mutant backgrounds (Figure 3.20 C). The decrease in expression in the DD mns ranged from partial to complete as shown in Figure 3.21 D. Twenty eight double mutant animals were observed. A reduction was seen in the intensities of the DD mns (Figure 3.20 C, D) however the intensities were generally higher in the double mutants. This result suggests that the presence of the ALR-1 amplifies the absence of *e191* (Figure 3.20D).

In the older stages *punc-5::gfp* expression was seen in the DDs and VDs in each of the fourteen preps in the double mutant. No expression was observed in the ASs suggesting that ALR-1 is necessary for expression in the AS mns (Figure 3.21).

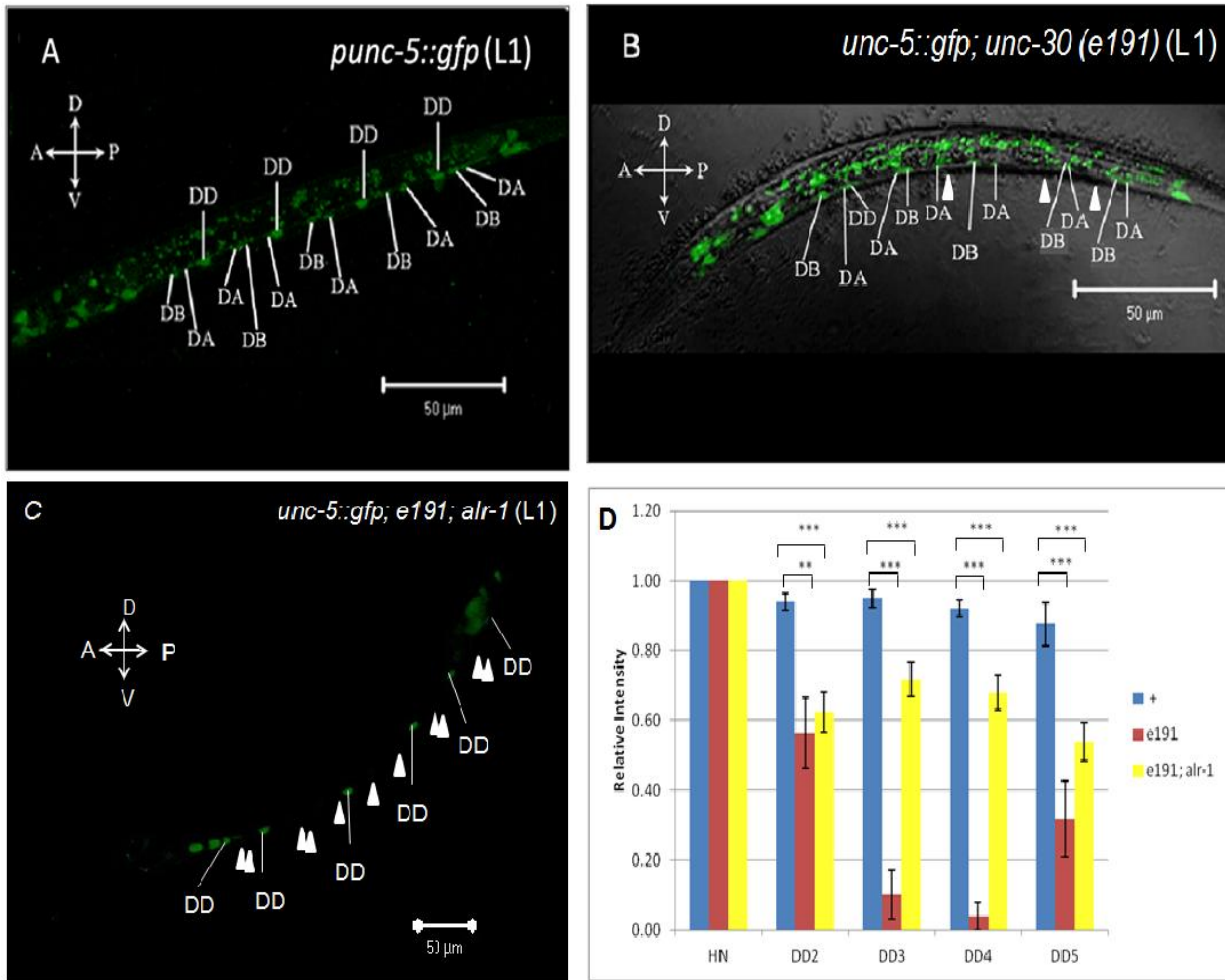

Figure 3.20 : (A, B, C) Comparison of expression in wild type *punc-5::gfp*, *unc-30 (e191)* and in double mutants *unc-30 (e191); alr-1* in L1 stage. Left is anterior, right is posterior, dorsal is up and ventral is down in all the preps. Scale is 50 μ m. (D) Graph represents the change in the intensity in the DDs at L1 stage with respect to the head neuron. n=17, 18 and 28 for wt and *e191*, *alr-1* double mutant backgrounds. Significance calculated using the student's t test where * $p < 0.05$, ** $p < 0.005$, *** $p < 0.001$

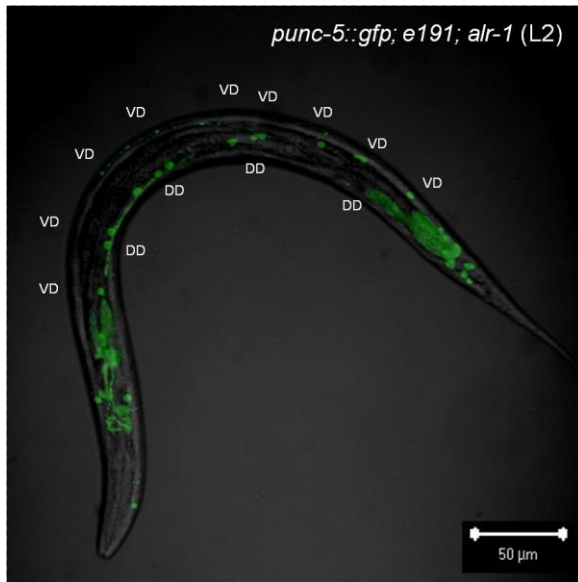

Figure 3.21 : Expression in *punc-5::gfp* double mutants *unc-30 (e191); alr-1* in L2 stage. Left is anterior, right is posterior, dorsal is up and ventral is down. Scale is 50 μm . n= 14.

S

3.3.3 *punc-104::gfp* reporter

3.3.3.1 Control *punc-104::gfp*

In the L1 stage, in the wild type animals, expression was seen in fifteen cells: four DDs, six DAs and five DBs in each of the twenty one animals (Figure 3.22 A).

In the L2 stage, a more variable expression pattern was observed. Fourteen controls were analyzed. In six control animals, one to three DDs were absent and up to 7 VDAs were missing (Figure 3.23 A). But in most animals cells corresponding to the positions of the ASs were observed. AS2 was on in 14 %, AS3 was on 36%, AS4, AS 8 and AS 10 were on 21% and AS5 was on 36% of the time.

3.3.3.2 *punc-104::gfp; unc-30 (e191)*

In L1 stage, *punc-104::gfp; unc-30 (e191)* mutant background, the DDs showed a reduction in the intensity of expression and the number of cells as compared to the wild type. Twenty worms were analyzed. DD2 lacked GFP expression 65% of the time whereas the other DDs failed to express GFP less

than 25 % of the time (Figure 3.22 B, D). The expression in the cholinergic mns (DAs and DBs) was not affected.

In the L2 stage, in the sixteen animals in the *e191* background, zero to four DDs and zero to five VDs were missing in some preps. There was loss of intensity of expression in some of the D mns (Figure 3.23 B, D, E). Additional cells: ASs were also observed as in the wild type. AS 2 and AS5 were seen in 25%, AS4 and AS9 in 12.5%, AS8 in 62% and AS10 in 44% of preps observed. In addition to the ASs, one or two additional cells were observed along with AS10 in three worms.

3.3.3.3 *punc-104::gfp; unc-30 (e191); alr-1 (oy42)*

The reporter *punc-104::gfp* in the double mutant background in the L1 stage too showed the loss of expression in the cholinergic mns and a loss of expression in most DDs as seen in the single mutant backgrounds in each of the twenty five worms analyzed (Figure 3.22 C and D). Figure 3.22 C shows one such double mutant worm in which the expression is lost in DD2-6 and all the cholinergic mns. The decrease in intensity in each mn was found to be highly significant (Figure 3.22 D).

In the L2 stage in the *punc-104::gfp* worms, the D mns as well as the AS mns expressed the reporter. But in the doubles, expression observed in some of D mns but was completely lost in the AS mns. Four out of the twelve animals showed a complete loss of expression in the D mns as well. The other eight showed partial loss (Figure 3.23 C). There was also a decrease in intensities in some of D mns, which was more significant than it was in *e191* background (Figure 3.23 D, E).

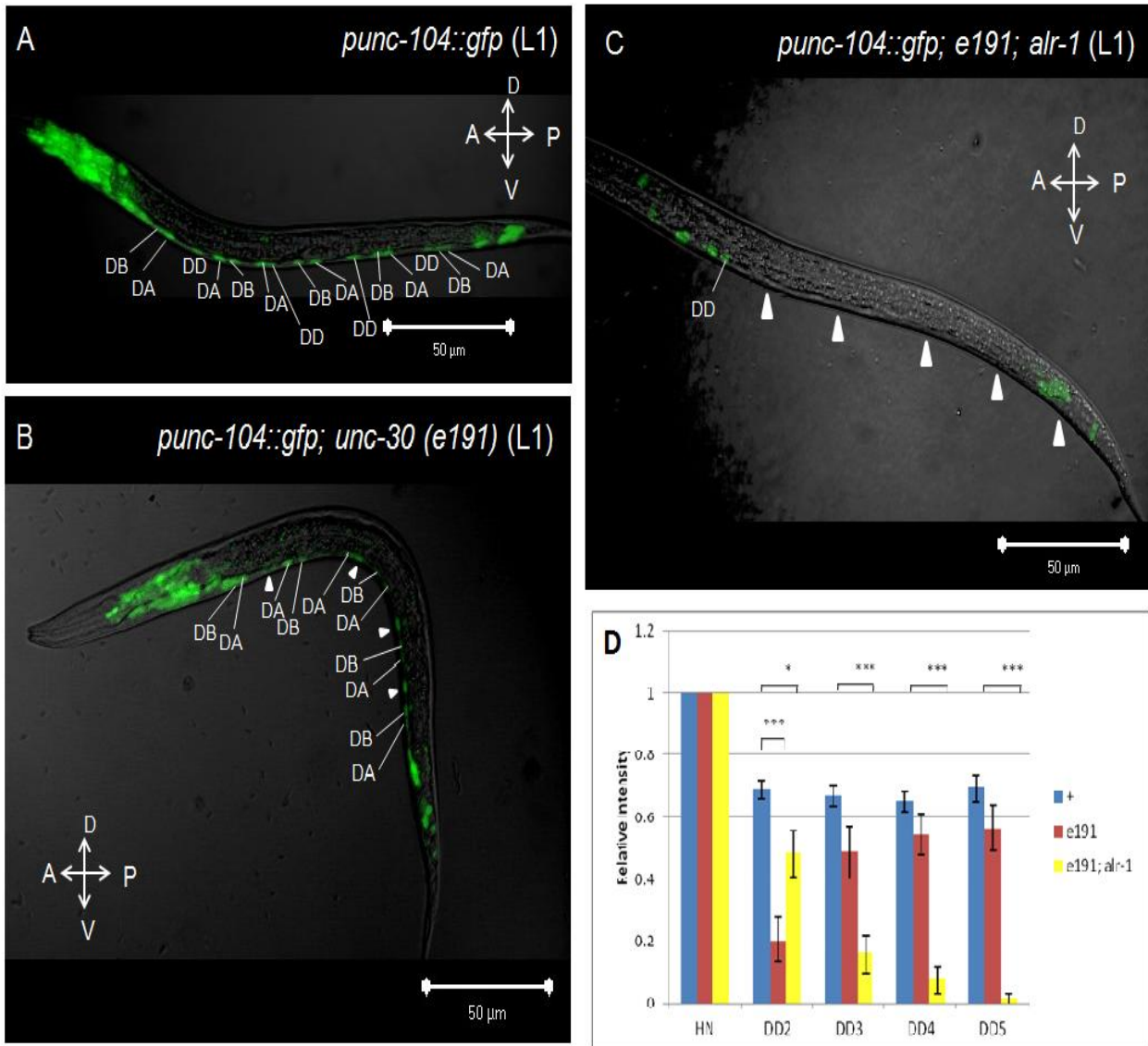

Figure 3.22 : (A, B, C) Comparison of expression in wild type *punc-104::gfp*, *unc-30 (e191)* and in double mutants *unc-30* (allele *e191*); *alr-1* in L1 stage. Left is anterior, right is posterior, dorsal is up and ventral is down in all the preps. Scale is 50 μ m. (D) Graph represents the change in the intensity in the DDs at L1 stage with respect to the head neuron. n=21, 20 and 25 for wt, *e191* and *e191, alr-1* double mutant backgrounds. Significance calculated using the student's t test where * p<0.05, ** p<0.005, *** p<0.001

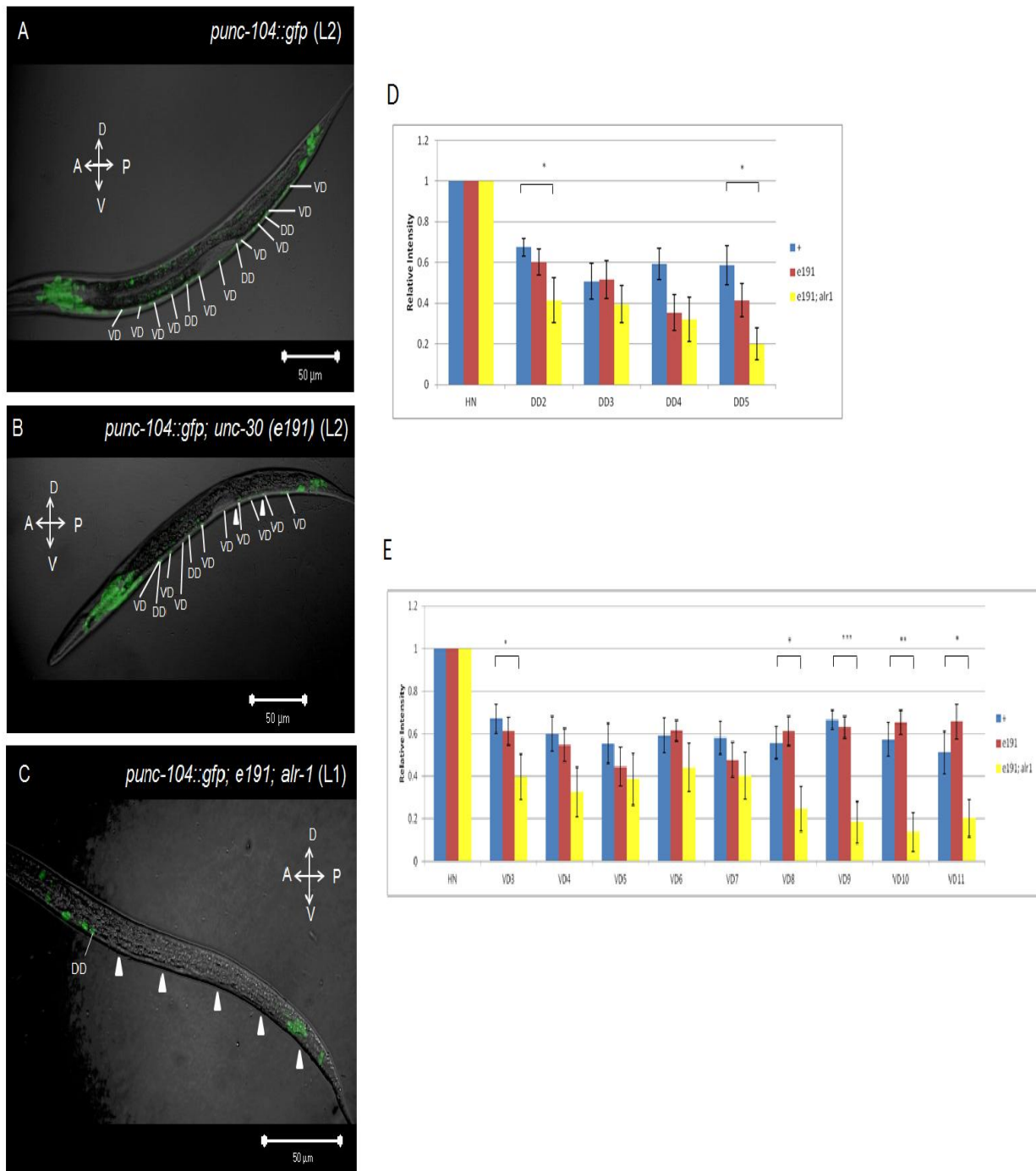

Figure 3.23: (A, B, C) Comparison of expression in wild type *punc-104::gfp*, *unc-30(e191)* and in double mutants *unc-30 (e191); alr-1* in L2 stage. Left is anterior, right is posterior, dorsal is up and ventral is down in all the preps. Scale is 50 μ m. (D, E) Graph represents the change in the intensity in the DDs at L2 stage with respect to the head neuron. n=14, 16 and 12 for wt, *e191* and *e191, alr-1* double mutant backgrounds. Significance calculated using the student's t test where * $p < 0.05$, ** $p < 0.005$, *** $p < 0.001$

These results suggest that ALR-1 acts synergistically with UNC-30 to regulate the expression of *punc-104::gfp* in the D mns but not in the *punc-5::gfp* and *pflp-11::gfp*.

4 DISCUSSION

The analysis of the role of a terminal selector UNC-30 in the regulation of genes expressed in multiple classes of neurons revealed that UNC-30 contributed to the activation in the D mns. However, the importance of the contribution of UNC-30 for expression in the D mns varied. Mutations in both alleles of *unc-30*, based upon the lesions, would be expected to make little if any functional protein. Nevertheless in both mutants, *pflp-11::gfp* and *punc-5::gfp* reporters showed occasional expression in the D mns neurons, regulated by the terminal selector gene, *unc-30*. *pflp-11::gfp*, normally expressed in three of the eight mn classes showed dramatic decrease in intensity and the number of detectable D mns. In *punc-5::gfp*, expressed in five of eight mn classes, a significant decrease in the intensity and number of D mns was noted as well.

The effect of the mutated form of UNC-30 appeared to have the least impact on the expression of the pan-neuronal gene *unc-104* where the comparisons showed subtle differences. Interestingly, the expression of *punc-104::gfp* in the *unc-30;alr-1* double mutant was decreased more than it was in a single mutant of *unc-30* suggesting that UNC-30 and ALR-1 may act together to regulate this gene reporter. Another possibility is that ALR-1 would regulate the expression of *unc-30* in the DD mns. In the absence of *alr-1*, the expression of *punc-30::gfp* was variable. In some animals, all the D mns were positive for *punc-30::gfp* while in the others, the GFP expression was diminished (Topalidou et al., 2011). ALR-1 has been implicated in the expression of chemosensory, mechanosensory and mns to play regulatory roles. In the mechanosensory neurons, it appears to play an important role in the maintenance of the differentiated state (Topalidou and Chalfie, 2011). Our result suggests that ALR-1 acts as a modulator of gene transcription enabling some genes to be greatly expressed whereas, suppressing levels of gene expression for other genes. ALR-1 thus decreases variability of expression by assisting the terminal selector UNC-30 to define characteristics to the D mns (Topalidou et al., 2011).

Our analysis with *unc-25*, *flp-11* and *unc-5* revealed that these genes are spatially regulated in the embryonic mns from the anterior to posterior of the animal in both L1 and L2 stages (more distinctly in the L1 than in L2). The DDs near the head are regulated by UNC-30 to a lesser degree than the posterior DDs as seen by the decrease in intensity of GFP expression in the absence of *unc-30* (both *e191* and *ok613*) or the *alr-1*, *unc-30* (*e191*) doubles, along the length of the animal.

The spatial regulation of the embryonic mns can be attributed to either one or a combination of the three possibilities. The first possibility being, differences in developmental origins among the DDs cause the DDs to be more strongly regulated in the posterior than the anterior of the animal by UNC-30. DDs originate from different l/r divisions of the founder cell AB.p. The anterior DDs, DD1 and DD2, are distant cousins originating from the anterior division of symmetric l/r founder cell whereas DD 3-6 are from the posterior divisions of these symmetric divisions of posterior l/r AB.p cells. Another possibility could be the involvement of heterochronic genes in the regulation of these genes. Heterochronic genes are known to regulate temporal expression. One such heterochronic transcription factor, Hunckback like-1 (HBL-1), is responsible for spatial patterning during DD remodeling. In the L1 stage, the DD innervate ventral muscle. As the animal molts, these synapses are eliminated from the ventral side and transported to the dorsal side. *hbl-1* is expressed in the DDs but its expression is suppressed in the VDs by UNC-55. In an *hbl-1* mutant background, newly translocated dorsal synapses form near the commissures first, and then proceeded towards the distal axon. This suggests that remodeling in the DDs occurs in a spatial pattern from proximal to distal (Thompson-Peer et al., 2012). Another heterochronic gene *lin-14* determines the timing of DD remodeling. In the absence of *lin-14*, DD remodeling occurs early, initiating during embryogenesis instead of being initiated during late L1 (Hallam and Jin, 1998, Thompson-Peer et al., 2012).

A third possibility would include the involvement of TCF/LEF1-like transcription factor POP-1 and its cofactor β -catenin /SYS-1(Phillips et al., 2007). POP-1 is expressed in higher levels in anterior nuclei

than the posterior nuclei in each cell division in the early embryo (Lin et al., 1998) while β -catenin /SYS-1 is distributed in a mirror-image asymmetric pattern (Phillips et al., 2007). Thus each cell experiences a specific distribution of POP-1/SYS-1 regulatory signals in addition to defined transcription factors as it undergoes a/p divisions. The interactions between these need further investigation. But changes in the activity of *pop-1* at different stages of embryonic development and lineages have shown the ubiquitous involvement of the POP-1 system in embryonic neuronal development (Bertrand and Hobert, 2009).

The postembryonic VD mns do not show such trends in the expression along the anterior-posterior axis of the animal. Expression of UNC-30 is strongest in the early L1 and L2 stages, after which it starts to decrease (WS210). This may attribute to the near constant expression observed in the later stages.

Expression in DDs for the pan neuronal gene, *unc-104*, did not follow the spatial trend in the L1 stage. In fact, the intensities showed an opposite (increasing) trend in *e191* allele or remained almost the same in the *ok613* allele. In the L2, the intensity of expression in the DDs seemed to be showing a similar decreasing trend but to a lesser degree in both mutant backgrounds. The expression in each VD remained almost equal. But in the double mutants of *alr-1* and *unc-30 (e191)*, the *unc-104* gene intensities in both D mns showed similar trends like the other reporters in both L1 and L2 stages. This suggests that the regulation of genes occur not only in a class specific manner, but their expression is seen to be graded along the length of the animal.

Transcription factors such as UNC-30 and ALR-1 and their cis regulatory elements are conserved across species. UNC-30 has vertebrate and invertebrate orthologues. Included in the vertebrates are Ptx1 (Lamonerie et al., 1996), RIEG/Ptx2/Brx1 (Semina et al., 1996, Gage and Camper, 1997, Kitamura et al., 1997), Ptx2 (Logan et al., 1998, Piedra et al., 1998, Yoshioka et al., 1998) and Crx (Chen et al., 1997, Furukawa et al., 1997) family of homeodomain proteins. Among the invertebrates is the bicod family of transcription factors. The studied transcription factor binds to the core DNA at a site TAATCC (Lamonerie

et al., 1996, Chen et al., 1997, Eastman et al., 1999). An orthologue of the transcription factor ALR-1, *aristaless* is expressed in *Drosophila* (Schneitz et al., 1993, Topalidou et al., 2011), *Arx* in mouse and humans (Bienvenu et al., 2002, Kitamura et al., 2002, Yoshihara et al., 2005, Topalidou et al., 2011).

Mutations within functional cis elements interfere with gene regulation. Ge Shan altered the *unc-30* binding site in *pflp-13::gfp* animals and the expression was abolished in each of the animal (Shan et al., 2005). Expression of genes may be thought of a probabilistic function. If so the terminal selector genes change the likelihood of activation of the selected targets. The effect of such transcription factor cannot be considered as all or none function.

A single transcription factor binds to a given cis-element. An exception to this rule are mechanosensory neurons in which heterodimers composed of MEC-3 and UNC-86 bind synergistically to control genes regulating touch reception (Xue et al., 1992, Duggan et al., 1998, Hobert, 2008). In AIY neurons two terminal selector genes regulate differentiated gene expression: TTX-3 LIM homeodomain protein and the CEH-10 Paired-type homeodomain protein (Wenick and Hobert, 2004). Loss of either of the homeodomain proteins causes a loss of their identity but the pan neuronal genes are still expressed. Position of cell bodies and morphology are not affected (Hobert, 2008).

Our analysis on the three reporters revealed a number of transcription factors apart from ALR-1 that would possibly be involved in the regulation the three reporters in the D mns network. A consortium of laboratories working under the NIH called model system encyclopedia of DNA (modENCODE) have performed chromatin immunoprecipitation experiments on the recognized transcription factors and deposited the data in a publicly accessible database. This analysis revealed EOR-1, PHA-1, MEP-1, BLMP-1, HLH-1, LIN-39, MAB-5, UNC-62, ZAG-1 and EGL-5 to be involved in the regulation of *unc-5*, EOR-1, MEP-1, LIN-39; MAB-5; UNC-62; ZAG-1; EGL-5; CEH-30; CES-1; GEI-11; HLH-8; NHR-62; PES-1 and SKN-1 for *unc-104* while *flp-11* is regulated by ALR-1 alone. This analysis suggests that a complex of transcription factors may be involved in gene regulation and increase the complexity.

In addition, ALR-1 regulates the expression of *unc-5* and *unc-104* genes and their reporters in the cholinergic mns. ALR-1 is expressed in the 24 of 26 GABAergic neurons (Melkman and Sengupta, 2005) and has not been reported to be expressed in the cholinergic mns. This throws light on cell-cell interactions and their possibly roles in the regulation of genes in classes where they are not expressed. Within D mns, neuropeptides are expressed. These may serve as cell signaling molecules initiating the expression of genes within the adjacent cholinergic motor neurons. Further investigation needs to be done to support this idea.

We can conclude that transcriptional regulatory pathways are surprisingly complex. First, the MUSSA analysis showed a great deal of similarity among the promoters, regions of DNA that are neither transcribed nor translated. Within these regions we find a surprisingly large number and variety of conserved cis-elements. This offers, a potential to a variety of combinations of transcription factors in a variety of contexts. The analysis of *unc-5*, *flp-11* and *unc-104* gene reporters, expressed in multiple classes of mns, revealed that all of the targeted promoters are regulated to varying degrees by the class specific transcription factor UNC-30. Moreover, the regulation of these genes is spatially regulated in the embryonic mns but not in the post embryonic mns. Future studies could be performed on terminal selector genes such as *mec-3* and *unc-86*, terminal selector genes for the mechanosensory neurons (Duggan et al., 1998, Zhang et al., 2002), *unc-3*, the terminal selector gene for the cholinergic mn classes, DA and DB (Von Stetina et al., 2006). As well as the chemosensory terminal selector gene, *che-1* (Uchida et al., 2003).

REFERENCES

- Akin ZN, Nazarali AJ (2005) Hox genes and their candidate downstream targets in the developing central nervous system. *Cellular and molecular neurobiology* 25:697-741.
- Bertrand V, Hobert O (2009) Linking asymmetric cell division to the terminal differentiation program of postmitotic neurons in *C. elegans*. *Developmental cell* 16:563-575.
- Bienvenu T, Poirier K, Friocourt G, Bahi N, Beaumont D, Fauchereau F, Ben Jeema L, Zemni R, Vinet MC, Francis F, Couvert P, Gomot M, Moraine C, van Bokhoven H, Kalscheuer V, Frints S, Geicz J, Ohzaki K, Chaabouni H, Fryns JP, Desportes V, Beldjord C, Chelly J (2002) ARX, a novel Prd-class-homeobox gene highly expressed in the telencephalon, is mutated in X-linked mental retardation. *Human molecular genetics* 11:981-991.
- Brenner S (1974) The genetics of *Caenorhabditis elegans*. *Genetics* 77:71-94.
- Celniker SE, Dillon LA, Gerstein MB, Gunsalus KC, Henikoff S, Karpen GH, Kellis M, Lai EC, Lieb JD, MacAlpine DM, Micklem G, Piano F, Snyder M, Stein L, White KP, Waterston RH, mod EC (2009) Unlocking the secrets of the genome. *Nature* 459:927-930.
- Chalfie M, Sulston J (1981) Developmental genetics of the mechanosensory neurons of *Caenorhabditis elegans*. *Developmental biology* 82:358-370.
- Chen S, Wang QL, Nie Z, Sun H, Lennon G, Copeland NG, Gilbert DJ, Jenkins NA, Zack DJ (1997) Crx, a novel Otx-like paired-homeodomain protein, binds to and transactivates photoreceptor cell-specific genes. *Neuron* 19:1017-1030.
- Cinar H, Keles S, Jin Y (2005) Expression profiling of GABAergic motor neurons in *Caenorhabditis elegans*. *Current biology* : CB 15:340-346.
- Degnan BM, Degnan SM, Giusti A, Morse DE (1995) A hox/hom homeobox gene in sponges. *Gene* 155:175-177.
- Doe CQ, Goodman CS (1985) Early events in insect neurogenesis. II. The role of cell interactions and cell lineage in the determination of neuronal precursor cells. *Developmental biology* 111:206-219.
- Duggan A, Ma C, Chalfie M (1998) Regulation of touch receptor differentiation by the *Caenorhabditis elegans* *mec-3* and *unc-86* genes. *Development* 125:4107-4119.
- Eastman C, Horvitz HR, Jin Y (1999) Coordinated transcriptional regulation of the *unc-25* glutamic acid decarboxylase and the *unc-47* GABA vesicular transporter by the *Caenorhabditis elegans* UNC-30 homeodomain protein. *The Journal of neuroscience : the official journal of the Society for Neuroscience* 19:6225-6234.
- Furukawa T, Morrow EM, Cepko CL (1997) Crx, a novel otx-like homeobox gene, shows photoreceptor-specific expression and regulates photoreceptor differentiation. *Cell* 91:531-541.
- Gage PJ, Camper SA (1997) Pituitary homeobox 2, a novel member of the bicoid-related family of homeobox genes, is a potential regulator of anterior structure formation. *Human molecular genetics* 6:457-464.
- Gehring WJ, Affolter M, Burglin T (1994) Homeodomain proteins. *Annual review of biochemistry* 63:487-526.
- Gerstein MB, Lu ZJ, Van Nostrand EL, Cheng C, Arshinoff BI, Liu T, Yip KY, Robilotto R, Rechtsteiner A, Ikegami K, Alves P, Chateigner A, Perry M, Morris M, Auerbach RK, Feng X, Leng J, Vielle A, Niu W, Rhrissorrakrai K, Agarwal A, Alexander RP, Barber G, Brdlik CM, Brennan J, Brouillet JJ, Carr A, Cheung MS, Clawson H, Contrino S, Dannenberg LO, Dernburg AF, Desai A, Dick L, Dose AC, Du J, Egelhofer T, Ercan S, Euskirchen G, Ewing B, Feingold EA, Gassmann R, Good PJ, Green P, Gullier F, Gutwein M, Guyer MS, Habegger L, Han T, Henikoff JG, Henz SR, Hinrichs A, Holster H, Hyman T, Iniguez AL, Janette J, Jensen M, Kato M, Kent WJ, Kephart E, Khivansara V, Khurana E, Kim JK, Kolasinska-Zwierz P, Lai EC, Latorre I, Leahey A, Lewis S, Lloyd P, Lochovsky L, Lowdon RF,

- Lubling Y, Lyne R, MacCoss M, Mackowiak SD, Mangone M, McKay S, Mecnas D, Merrihew G, Miller DM, 3rd, Muroyama A, Murray JI, Ooi SL, Pham H, Phippen T, Preston EA, Rajewsky N, Ratsch G, Rosenbaum H, Rozowsky J, Rutherford K, Ruzanov P, Sarov M, Sasidharan R, Sboner A, Scheid P, Segal E, Shin H, Shou C, Slack FJ, Slightam C, Smith R, Spencer WC, Stinson EO, Taing S, Takasaki T, Vafeados D, Voronina K, Wang G, Washington NL, Whittle CM, Wu B, Yan KK, Zeller G, Zha Z, Zhong M, Zhou X, mod EC, Ahringer J, Strome S, Gunsalus KC, Micklem G, Liu XS, Reinke V, Kim SK, Hillier LW, Henikoff S, Piano F, Snyder M, Stein L, Lieb JD, Waterston RH (2010) Integrative analysis of the *Caenorhabditis elegans* genome by the modENCODE project. *Science* 330:1775-1787.
- Hallam SJ, Jin Y (1998) *lin-14* regulates the timing of synaptic remodelling in *Caenorhabditis elegans*. *Nature* 395:78-82.
- Hedgecock EM, Culotti JG, Thomson JN, Perkins LA (1985) Axonal guidance mutants of *Caenorhabditis elegans* identified by filling sensory neurons with fluorescein dyes. *Developmental biology* 111:158-170.
- Heffer A, Shultz JW, Pick L (2010) Surprising flexibility in a conserved Hox transcription factor over 550 million years of evolution. *Proceedings of the National Academy of Sciences of the United States of America* 107:18040-18045.
- Hobert O (2008) Regulatory logic of neuronal diversity: terminal selector genes and selector motifs. *Proceedings of the National Academy of Sciences of the United States of America* 105:20067-20071.
- Jin Y, Hoskins R, Horvitz HR (1994) Control of type-D GABAergic neuron differentiation by *C. elegans* UNC-30 homeodomain protein. *Nature* 372:780-783.
- Kim S, Park SY, Kim KS, Rho HS, Chi MH, Choi J, Park J, Kong S, Park J, Goh J, Lee YH (2009) Homeobox transcription factors are required for conidiation and appressorium development in the rice blast fungus *Magnaporthe oryzae*. *PLoS genetics* 5:e1000757.
- Kitamura K, Miura H, Yanazawa M, Miyashita T, Kato K (1997) Expression patterns of *Brx1* (Rieg gene), Sonic hedgehog, *Nkx2.2*, *Dlx1* and *Arx* during zona limitans intrathalamica and embryonic ventral lateral geniculate nuclear formation. *Mechanisms of development* 67:83-96.
- Kitamura K, Yanazawa M, Sugiyama N, Miura H, Iizuka-Kogo A, Kusaka M, Omichi K, Suzuki R, Kato-Fukui Y, Kamiirisa K, Matsuo M, Kamijo S, Kasahara M, Yoshioka H, Ogata T, Fukuda T, Kondo I, Kato M, Dobyns WB, Yokoyama M, Morohashi K (2002) Mutation of *ARX* causes abnormal development of forebrain and testes in mice and X-linked lissencephaly with abnormal genitalia in humans. *Nature genetics* 32:359-369.
- Kuntz SG, Schwarz EM, DeModena JA, De Buysscher T, Trout D, Shizuya H, Sternberg PW, Wold BJ (2008) Multigenome DNA sequence conservation identifies Hox cis-regulatory elements. *Genome research* 18:1955-1968.
- Lamonerie T, Tremblay JJ, Lanctot C, Therrien M, Gauthier Y, Drouin J (1996) *Ptx1*, a bicoid-related homeo box transcription factor involved in transcription of the pro-opiomelanocortin gene. *Genes & development* 10:1284-1295.
- Lappin TR, Grier DG, Thompson A, Halliday HL (2006) HOX genes: seductive science, mysterious mechanisms. *The Ulster medical journal* 75:23-31.
- Lin R, Hill RJ, Priess JR (1998) POP-1 and anterior-posterior fate decisions in *C. elegans* embryos. *Cell* 92:229-239.
- Logan M, Pagan-Westphal SM, Smith DM, Paganessi L, Tabin CJ (1998) The transcription factor *Pitx2* mediates situs-specific morphogenesis in response to left-right asymmetric signals. *Cell* 94:307-317.
- McIntire SL, Reimer RJ, Schuske K, Edwards RH, Jorgensen EM (1997) Identification and characterization of the vesicular GABA transporter. *Nature* 389:870-876.

- Melkman T, Sengupta P (2005) Regulation of chemosensory and GABAergic motor neuron development by the *C. elegans* *Aristaless/Arx* homolog *alr-1*. *Development* 132:1935-1949.
- Niu W, Lu ZJ, Zhong M, Sarov M, Murray JI, Brdlik CM, Janette J, Chen C, Alves P, Preston E, Slightham C, Jiang L, Hyman AA, Kim SK, Waterston RH, Gerstein M, Snyder M, Reinke V (2011) Diverse transcription factor binding features revealed by genome-wide ChIP-seq in *C. elegans*. *Genome research* 21:245-254.
- O'Leary DD, Nakagawa Y (2002) Patterning centers, regulatory genes and extrinsic mechanisms controlling arealization of the neocortex. *Current opinion in neurobiology* 12:14-25.
- Phillips BT, Kidd AR, 3rd, King R, Hardin J, Kimble J (2007) Reciprocal asymmetry of *SYS-1*/beta-catenin and *POP-1*/TCF controls asymmetric divisions in *Caenorhabditis elegans*. *Proceedings of the National Academy of Sciences of the United States of America* 104:3231-3236.
- Piedra ME, Icardo JM, Albajar M, Rodriguez-Rey JC, Ros MA (1998) *Pitx2* participates in the late phase of the pathway controlling left-right asymmetry. *Cell* 94:319-324.
- Price RL (2011) Setting the Operating Parameters. In: *Basic Confocal Microscopy* (Price, R. L. and Jerome, W. G. J., eds), pp 181-241 New York: Springer.
- Rivera-Pomar R, Jackle H (1996) From gradients to stripes in *Drosophila* embryogenesis: filling in the gaps. *Trends in genetics : TIG* 12:478-483.
- Schneitz K, Spielmann P, Noll M (1993) Molecular genetics of *aristaless*, a *prd*-type homeo box gene involved in the morphogenesis of proximal and distal pattern elements in a subset of appendages in *Drosophila*. *Genes & development* 7:114-129.
- Schug J (2008) Using TESS to predict transcription factor binding sites in DNA sequence. *Current protocols in bioinformatics / editorial board, Andreas D Baxevanis [et al] Chapter 2:Unit 2 6*.
- Semina EV, Reiter R, Leysens NJ, Alward WL, Small KW, Datson NA, Siegel-Bartelt J, Bierke-Nelson D, Bitoun P, Zabel BU, Carey JC, Murray JC (1996) Cloning and characterization of a novel bicoid-related homeobox transcription factor gene, *RIEG*, involved in Rieger syndrome. *Nature genetics* 14:392-399.
- Shan G, Kim K, Li C, Walthall WW (2005) Convergent genetic programs regulate similarities and differences between related motor neuron classes in *Caenorhabditis elegans*. *Developmental biology* 280:494-503.
- Shankland M (1991) Leech segmentation: cell lineage and the formation of complex body patterns. *Developmental biology* 144:221-231.
- Sulston JE, Horvitz HR (1977) Post-embryonic cell lineages of the nematode, *Caenorhabditis elegans*. *Developmental biology* 56:110-156.
- Sulston JE, Schierenberg E, White JG, Thomson JN (1983) The embryonic cell lineage of the nematode *Caenorhabditis elegans*. *Developmental biology* 100:64-119.
- Thompson-Peer KL, Bai J, Hu Z, Kaplan JM (2012) *HBL-1* patterns synaptic remodeling in *C. elegans*. *Neuron* 73:453-465.
- Topalidou I, Chalfie M (2011) Shared gene expression in distinct neurons expressing common selector genes. *Proceedings of the National Academy of Sciences of the United States of America* 108:19258-19263.
- Topalidou I, van Oudenaarden A, Chalfie M (2011) *Caenorhabditis elegans* *aristaless/Arx* gene *alr-1* restricts variable gene expression. *Proceedings of the National Academy of Sciences of the United States of America* 108:4063-4068.
- Uchida O, Nakano H, Koga M, Ohshima Y (2003) The *C. elegans* *che-1* gene encodes a zinc finger transcription factor required for specification of the ASE chemosensory neurons. *Development* 130:1215-1224.

- Vermeirssen V, Barrasa MI, Hidalgo CA, Babon JA, Sequerra R, Doucette-Stamm L, Barabasi AL, Walhout AJ (2007) Transcription factor modularity in a gene-centered *C. elegans* core neuronal protein-DNA interaction network. *Genome research* 17:1061-1071.
- Von Stetina SE, Treinin M, Miller DM, 3rd (2006) The motor circuit. *International review of neurobiology* 69:125-167.
- Walthall WW (1995) The Nervous Systems of Invertebrates: An Evolutionary and Comparative Approach. In: Repeating patterns of motoneurons in nematodes: The origin of segmentation? (Breidbach, O. and Kutsch, W., eds), pp 61-75 Basel: Birkhäuser Verlag.
- Wang BB, Muller-Immergluck MM, Austin J, Robinson NT, Chisholm A, Kenyon C (1993) A homeotic gene cluster patterns the anteroposterior body axis of *C. elegans*. *Cell* 74:29-42.
- Wenick AS, Hobert O (2004) Genomic cis-regulatory architecture and trans-acting regulators of a single interneuron-specific gene battery in *C. elegans*. *Developmental cell* 6:757-770.
- Williams RW (1998) Plant homeobox genes: many functions stem from a common motif. *BioEssays : news and reviews in molecular, cellular and developmental biology* 20:280-282.
- Xue D, Finney M, Ruvkun G, Chalfie M (1992) Regulation of the *mec-3* gene by the *C. elegans* homeoproteins UNC-86 and MEC-3. *The EMBO journal* 11:4969-4979.
- Yoshihara S, Omichi K, Yanazawa M, Kitamura K, Yoshihara Y (2005) *Arx* homeobox gene is essential for development of mouse olfactory system. *Development* 132:751-762.
- Yoshioka H, Meno C, Koshiba K, Sugihara M, Itoh H, Ishimaru Y, Inoue T, Ohuchi H, Semina EV, Murray JC, Hamada H, Noji S (1998) *Pitx2*, a bicoid-type homeobox gene, is involved in a lefty-signaling pathway in determination of left-right asymmetry. *Cell* 94:299-305.
- Zhang Y, Ma C, Delohery T, Nasipak B, Foat BC, Bounoutas A, Bussemaker HJ, Kim SK, Chalfie M (2002) Identification of genes expressed in *C. elegans* touch receptor neurons. *Nature* 418:331-335.