

The Getty Conservation Institute

research in  
conservation

# Oxygen-Free Museum Cases

Edited by Shin Maekawa

# Oxygen-Free Museum Cases

The Getty Conservation Institute

**research in conservation**

# Oxygen-Free Museum Cases

Edited by Shin Maekawa

1998

Dinah Berland, *Managing Editor*  
Judith Abrahms, *Manuscript Editor*  
Amita Molloy, *Production Coordinator*  
Garland Kirkpatrick, *Series Designer*

Printed in the United States of America  
10 9 8 7 6 5 4 3 2 1

©1998 by the J. Paul Getty Trust  
All rights reserved.

Library of Congress Cataloging-in-Publication Data  
Oxygen-free museum cases / edited by Shin Maekawa.  
p. cm.—(Research in conservation)  
Includes bibliographical references and index.  
ISBN 0-89236-529-3

1. Museum conservation methods—Research. 2. Museum exhibits—Conservation and restoration. 3. Mummy cases—Design and construction. 4. Material culture—Conservation and restoration. 5. Cultural property—Protection. I. Maekawa, Shin, 1952- . II. Series.

AM145.O9 1998  
069'.53—dc21

98-15964  
CIP

# The Getty Conservation Institute

The Getty Conservation Institute works internationally to further the appreciation and preservation of the world's cultural heritage for the enrichment and use of present and future generations. The Institute is an operating program of the J. Paul Getty Trust.

## Research in Conservation

The Research in Conservation reference series presents the findings of research conducted by the Getty Conservation Institute and its individual and institutional research partners, as well as state-of-the-art reviews of conservation literature. Each volume covers a topic of current interest to conservators and conservation scientists. Other volumes in the Research in Conservation series include *Inert Gases in the Control of Museum Insect Pests* (Selwitz and Maekawa 1998); *Stone Conservation: An Overview of Current Research* (Price 1996); *Accelerated Aging: Photochemical and Thermal Aspects* (Feller 1994); *Airborne Particles in Museums* (Nazaroff, Ligoeki, et al. 1993); *Epoxy Resins in Stone Consolidation* (Selwitz 1992); *Evaluation of Cellulose Ethers for Conservation* (Feller and Wilt 1990); *Cellulose Nitrate in Conservation* (Selwitz 1988); and *Statistical Analysis in Art Conservation Research* (Reedy and Reedy 1988).

# Contents

- ix Foreword  
*Miguel Angel Corzo*
- xi Preface  
*Shin Maekawa*
- 1 Chapter 1 Conservation of the Royal Mummy Collection at the Egyptian Museum  
*Shin Maekawa*
- 7 Chapter 2 Protection of Objects from Environmental Deterioration by Reducing Their Exposure to Oxygen  
*Eric F. Hansen*
- 17 Chapter 3 Preservation of Historic Materials by Using Inert Gases for Biodeterioration Control  
*Nieves Valentín*
- 31 Chapter 4 Design and Construction of the CCI's Hermetically Sealed Display and Storage Case  
*Shin Maekawa*
- 47 Chapter 5 Controlled-Environment Cases for the Royal Mummy Collection  
*Nasry Yousef Iskander*
- 53 Chapter 6 Preservation of the Original Documents of the Constitution of India  
*Hari Kishan and Shin Maekawa*
- 59 Chapter 7 Preservation of the Mummy of an Egyptian Child in a Hermetically Sealed Museum Case in Spain  
*Shin Maekawa*
- 65 Index
- 71 About the Authors

# Foreword

Over the course of the last ten years, the Getty Conservation Institute has been involved in projects that deal with oxygen-free environments as a means of preventing the deterioration of sensitive organic materials. The royal mummies of Egypt, the original documents of the Constitution of India, and the Royal Proclamation Charter for Hudson's Bay Company, Toronto, are the most notable examples of cultural objects conserved in this way. The research that led the Institute to adopt this solution was originally conceived for the specific problem of conserving the royal mummies at the Egyptian Museum in Cairo. The possibilities of other applications soon became evident.

This book covers the results of that research and its applications presented by several of the principal participants in the project. The purpose of this publication, in concert with other volumes in the Research in Conservation series, is to provide information that will be of interest and use to conservators and conservation scientists.

Shin Maekawa, editor of this volume, worked long and hard to guide much of the research and to give further coherence to the structure of the information presented. While a fellow at the GCI, Nieves Valentín first pointed the Institute in the direction of this research; her further responsibilities in Spain allowed her to continue along the lines she first established at the Institute. Nasry Yousef Iskander implemented much of the results in constructing cases for the Egyptian Museum in Cairo. Our gratitude is extended to each of these contributors.

Dinah Berland and her editorial colleagues have given this publication a notable readability, and Amita Molloy coordinated the book's production. Our sincere thanks to them. To our readers, I express the hope that you will communicate your comments to us, so that future volumes in this series can be further geared to the needs of the profession.

Miguel Angel Corzo  
Director  
The Getty Conservation Institute

# Preface

Shin Maekawa

In 1987, the Egyptian Antiquities Organization of the Egyptian Ministry of Culture and the Getty Conservation Institute (GCI), based in California, undertook a collaborative project for conserving the Royal Mummy Collection at the Egyptian Museum in Cairo. Studies were carried out at the Getty Conservation Institute on the efficacy of inert-gas atmospheres in preventing chemical and biological degradation of proteinaceous materials in long-term display or storage. The design and construction of a hermetically sealed, inert-gas-filled display and storage case was carried out at the Getty Conservation Institute. The research phase of the project ended with the presentation of a draft report and the delivery of a prototype hermetically sealed display and storage case to the Egyptian Antiquities Organization at the Egyptian Museum in May 1989. Implementation of the results, including the local fabrication of the cases in Egypt and conservation of the mummies, started immediately thereafter. After the project had ended, participants also continued research in their respective areas, with valuable new results. The Egyptian Antiquities Organization completed ten cases and opened the new Royal Mummy Room in March 1995. This publication was produced to disseminate the results of the project as well as to aid others who may wish to consider the use of hermetically sealed cases—significant aids to the long-term conservation of oxygen-sensitive objects.

Chapter 1 describes the background and development of tasks and summarizes the results of the project. Environmental recommendations for display and storage of proteinaceous materials are discussed in chapters 2 and 3. In chapter 2, Eric Hansen, an associate scientist at the Getty Conservation Institute, presents the results of his investigation of acceptable environmental parameters for the display and storage of Egyptian mummies and parchment to optimize their chemical and physical stability. In chapter 3, Nieves Valentín, research biologist at the Instituto del Patrimonio Histórico Español in Madrid, describes the environmental requirements for controlling biodeterioration of organic materials that are acted on by insects, fungi, and aerobic and anaerobic bacteria. Both Hansen and Valentín continued their research after the 1987-89 project, and major results of their extended investigations are included in these chapters.

Physical principles, the description and engineering details of the hermetically sealed display and storage cases, are discussed in chapter 4. Mechanical drawings and lists of components and their suppliers are also included. In chapter 5, Nasry Iskander, director of the Conservation Center at the Supreme Council of Antiquities, presents his experience in producing twenty-seven GCI-designed cases in Egypt using locally available materials. He also describes technical details of the newly opened Royal Mummy Room at the Egyptian Museum.

As a result of the successful design of the case, many cultural institutions have expressed interest in using it for their environmentally sensitive collections. The GCI has recently concluded two collaborative projects in which objects were successfully installed in hermetically sealed, inert-gas-filled display and storage cases. Chapter 6 gives details of the project undertaken with the National Physical Laboratory in New Delhi, India, to fabricate two hermetically sealed display cases for the original document of the Constitution of India, now displayed at the Parliament House in New Delhi. Chapter 7 presents a collaborative project to conserve the Egyptian mummy of a child at the Biblioteca-Museu Victor Balaguer in Vilanova i la Geltrú, Spain. Working with the Biblioteca-Museu, project participants included the Instituto del Patrimonio Histórico Español; the Getty Conservation Institute; and the Metode Company, an art conservation and installation firm in Barcelona. The conservation team designed a hermetically sealed, argon-filled display and storage case that was built in Spain.



## **Editor's Acknowledgment**

The editor would like to acknowledge Frank Lambert, professor emeritus at Occidental College, for his significant contribution to the development of the Getty Conservation Institute's hermetically sealed storage and display case, and for his advice in the editing of this publication.

# Conservation of the Royal Mummy Collection at the Egyptian Museum

Shin Maekawa

Organic materials in museums and collections are especially susceptible to deterioration caused by changes in humidity and temperature; attack by fungi, bacteria, or insects; the effects of photo-oxidation; and damage from gaseous and particulate air pollutants commonly found in urban and industrialized areas. The catastrophic damage inflicted by biological and microbiological attack on cultural treasures is well known. The harmful effects of these processes are commonly observed on delicate feather objects; on historic parchment documents; on mummified human remains; on biological specimens of rare or extinct species; and even on stone, where blackening or discoloration occurs. Just as well known is the fact that all such biological attack is accelerated by high relative humidity, which is a constant threat in an uncontrolled environment. Obviously, the deleterious effects of oxygen-dependent organisms such as insects, fungi, and aerobic bacteria on organic cultural objects (Rust and Kennedy 1993; Valentín and Preusser 1990; Valentín, Lindstrom, and Preusser 1990) would be eliminated if the objects could be maintained in a nitrogen or other oxygen-free atmosphere.

For some three thousand years, the remarkable skill of the ancient Egyptians in preserving the bodies of their pharaohs and others was coupled with environmental conditions of dryness and extreme temperature stability in tombs in the Valley of the Kings and the Valley of the Queens. These ancient techniques and environments resulted in superb conservation that provided an unparalleled bridge to the past, transporting the actual bodies of ancient rulers of Egypt and of some of their subjects into the future.

Relatively recently, the mummies in the Royal Mummy Collection were moved to simple museum cases in the Egyptian Museum in Cairo, an exceptionally busy metropolis with very few environmental regulations and all the disadvantages of a commercial city. The air is heavily polluted with oxidants as well as with particulate matter from automotive emissions, both of which are particularly deleterious to organic materials. The concentration of sand and dust particles is significantly high in the city because it is surrounded by a large desert. Moreover, the museum, because of its proximity to the Nile River, is much more humid at night and in the early morning hours than are the Valley of the Kings and the Valley of the Queens in the Egyptian desert. In addition, the museum, a hundred-year-old massive sandstone building, has neither air conditioning to control the temperature and humidity nor air filters to remove particles of diesel soot and other types of particulates and dust. It relies solely on open-window ventilation for control of the indoor climate. These environmental conditions— together with the large numbers of visitors to the world-famous museum, which also affects the microclimate within it—constitute a serious hazard to the continued preservation of the royal mummies and other sensitive collections.

In September 1976, the mummy of Ramses II, from the Royal Mummy Collection at the Egyptian Museum, was sent to Paris for conservation treatment at the Musée de l'Homme. After extensive documentation of the mummy and its condition, the infestation of *Daedalea biennis* Fries, a fungal species, was identified as the major cause of the deterioration. During the conservation work that followed, the mummy was placed in a custom-designed display case equipped with a special ventilator and was sterilized with gamma-ray radiation using cobalt-60. The mummy was flown back to Cairo in May 1978 and has been kept in the case since the treatment. Conservators at the Supreme Council of Antiquities have seen some color changes and have expressed their concern about possible alteration of genetic information in the mummy that may have resulted from its treatment (Nakhla and Iskander 1989).

In 1980, then-President Anwar el-Sadat closed the Egyptian Museum's Royal Mummy Room, which housed the mummified remains of twenty-seven kings

and queens of ancient Egypt, for religious reasons. The world's best collection of Egyptian mummies, which had been one of the most popular tourist attractions in Egypt, was removed from display. The mummies were stored in a sealed room on the museum's second floor under less than suitable environmental conditions. Sadat's decision was later reversed, and the Egyptian Antiquities Organization (now named the Supreme Council of Antiquities) started to plan an improved display of the mummy collection.

Thus it was that, in 1985, the Getty Conservation Institute was first approached by the Egyptian Antiquities Organization (EAO) with concerns about alleviating threats to the state of the royal mummies. It was the specific request of EAO officials not only that the mummies be protected from harmful environmental effects by a newly designed case, but that the case be both technically effective and visually superior for the display of mummies. In other words, the case should be both safe for storage and aesthetically acceptable for viewing by visitors.

In 1987, an agreement was signed by the EAO and the GCI for developing a display and storage case. The GCI was to be primarily responsible for design, construction, and testing. The EAO was to document the mummies and restore them to a state suitable for exhibition, as well as to investigate the microbiology of the mummies, of their wrappings and cases, and of the exhibition room environment. It was specified that the case should maintain a microenvironment characterized by an inert-gas atmosphere and a stable relative humidity.

A number of requirements for the display and storage case were defined by the GCI at the beginning of the project; these requirements would enable the projected case to have wider applications than that of protecting mummies: the preservation of every kind of organic artifact by means of a controlled microenvironment in any museum in the world, including those with limited funds for complex cases.

However, past attempts to develop display cases or storage units that used a nitrogen atmosphere and a controlled relative humidity either were extremely expensive or required considerable maintenance or monitoring of gas-flow equipment. Additional problems have always arisen when mechanical or electrical devices were attached to a case for humidity control. Accordingly, the GCI undertook the design and construction of a hermetically sealed case that could be filled with nitrogen or another inert gas and left unattended for an extended period. In the inert microenvironment of such a case, freedom from the possibility of aerobic biological harm to an artifact could be achieved. Cost and manufacturability were important constraints on research and development. It was believed that the final product must be as inexpensive as possible, meeting the stated goals at relatively low capital cost and with minimal maintenance. Finally, highly specialized tools or machines should not be necessary to build it. In summary,

- the cases should not be dependent on any mechanical or electrical systems;
- they should require little maintenance, no more often than every two years;
- it should be possible to manufacture and test the cases in developing countries; and
- the cost per case should be kept as low as possible.

## **Project Development**

The work plan for the project included two major areas of research: first, to establish ideal display and storage conditions for the mummies; second, to develop hardware that could maintain such conditions. The factors studied were the selection of an inert gas, the allowable level of oxygen, and optimal levels of

relative humidity, temperature, and illumination. The design of hardware proceeded parallel with research on storage conditions.

## Proposed Storage Conditions

Research on the environmental parameters affecting the chemical and physical stability of proteinaceous materials such as mummified tissues and parchment was conducted by Eric Hansen at the GCI. Nieves Valentín, a research biologist at the Instituto del Patrimonio Histórico Español in Madrid, carried out research on the efficacy of nitrogen atmospheres for controlling biological and microbiological activities on mummified tissues and parchment between 1987 and 1989, while working at the GCI as a research fellow. Valentín continued this research on her return to Madrid.

The following recommendations are based on these research projects and literature reviews. An oxygen-reduced inert atmosphere of nitrogen at low relative humidity suppresses both biological activity and oxidation in proteinaceous material. Studies have shown the complete eradication of all stages of major museum pests and significantly reduced microbiological activities where the oxygen concentration was maintained at less than 0.1 %. Clearly, the optimal oxygen level is zero; in reality, however, this is impractical, so it should be kept as close to zero as possible.

An ideal temperature range for the preservation of organic material is 10-15 °C. A lower temperature reduces reaction rates in general and specifically the denaturing of collagen, the major constituent of mummy skin. In a closed microenvironment, relative humidity fluctuations depend on temperature fluctuations. Lower temperature levels are desirable only if they do not increase humidity variation. Furthermore, other museological considerations, such as human comfort, make low temperatures undesirable in display and storage rooms. However, it is preferable to keep the temperature as constant and as low as possible.

An ideal relative humidity (RH) level is 30-50%. Values below 25% RH should be avoided owing to the possibility of permanent deformation arising from irreversible dehydration of proteinaceous material. As demonstrated by research at the GCI, microbiological activity on mummified tissue and parchment samples was significantly reduced in the nitrogen microenvironment when the relative humidity was below 50% RH. To remove oxygen that may leak into a case containing an inert gas, it is useful to add chemical substances—so-called oxygen absorbers—that react with oxygen. Most oxygen absorbers require moderate levels of moisture to react with oxygen. Reaction rates of the absorber called Ageless decreased considerably after it had been in a 33% RH atmosphere for a year; therefore, the higher level of about 45% RH is preferable if an oxygen absorber is used.

The spectral distribution of the light reaching an object should be restricted to the longest wavelengths that allow an acceptable appearance without any color cast. Restricting light wavelength as close as possible to a 400 nm cutoff is accomplished through the use of ultraviolet and possibly violet filters, the proper choice of an illuminant, or a combination of the two. The intensity of the lighting should be limited to less than 100 lux for sensitive organic materials.

## Display and Storage Case Design and Fabrication

A hermetically sealed display case for maintaining an inert-gas atmosphere was chosen over a continuous purging system, for the obvious reasons of the simplicity of the concept and the low maintenance required. The fabricated case consists of a display section, a bellows concealed below the display section, and a

rigid base support system. The pressure-free condition of the case, despite atmospheric pressure changes, is achieved by inflation and deflation of the bellows attached to the display section; this allows light construction of its hermetic seal. The temperature-induced volume changes of the case's gas are similarly automatically adjusted by the inflation and deflation of the bellows. The case is filled with humidity-conditioned nitrogen, is hermetically sealed from the surrounding atmosphere, and is monitored for oxygen content and relative humidity without needing to be opened (Fig. 1.1). Because of the extremely low leak rate of oxygen into the case, when it is initially filled with nitrogen, less than 2% oxygen will be present after ten years. If packets of an oxygen absorber are placed in the case, many additional years may elapse before the 2% oxygen level is exceeded. A relative humidity buffering material, silica gel, which has been conditioned at the selected humidity, is put in the case to provide a constant relative humidity to compensate for temperature variation and any moisture from the oxygen absorber or the displayed object.

Once the conceptual design was completed, a one-fifth scale model of the case was fabricated at the machine shop of the GCI and shipped to the EAO for approval. Detailed mechanical design and fabrication of a full-size prototype case (1000 l volume) were contracted to Lightsense Corp., Laguna Beach, Calif. The case was rigorously tested and various improvements in its design were implemented at the GCI.

The presentation of the project report and the installation of the prototype hermetically sealed display and storage case to the EAO were made at the Egyptian Museum in May 1989. The performance of the case was evaluated in situ for a period of two years in a non-air-conditioned room on the second floor of the museum, which was proposed for the permanent exhibition of the royal mummies. The oxygen leak rate of the case, approximately 20 ppm per day, was acceptable to both the EAO and the GCI.

Subsequently, additional design improvements for both better performance and simpler fabrication were made at the GCI and forwarded to the EAO for its production of cases for the royal mummies. Some of the cases' components that the EAO was unable to obtain in Egypt were identified, and the necessary quantity of the components to build twenty-seven cases was donated to the EAO by the GCI. In addition to the aforementioned items, a set of aluminum extrusions for

Figure 1.1

Photograph of the nitrogen-filled, hermetically sealed display and storage case developed during the collaborative project to preserve the Royal Mummy Collection at the Egyptian Museum in Cairo. Photo by T. Moon.



fabricating one complete case was given to the EAO for its first case. Production of that case was carried out by the Supreme Council of Antiquities for its Royal Mummy Collection in the Egyptian Museum in Cairo. Fabrication of other cases was conducted in close consultation with the GCI until 1995. Eleven of the royal mummies were placed in the GCI-designed cases (the prototype case and ten Egyptian-built cases), and the new Royal Mummy Room, which is climate-controlled, was officially opened to the public in March 1994. As of December 1996, the Supreme Council of Antiquities had completed the assembly of fifteen cases.

## Acknowledgments

Frank Preusser, then-director of the Scientific Program at the GCI, managed the project between 1987 and 1989; Neville Agnew, now group director, Information and Communications, at the GCI, assumed its management after that date. GCI consultant Frank Lambert provided significant contributions to the testing and improvement of the case, as well as research on the Ageless oxygen absorber. Steven Weintraub, then head of conservation processes at the GCI, and George Rogers, then senior research fellow at the GCI, provided input during the initial stage of the case design.

## References

**Nakhla, Shawky, and Nasry Iskander**

1989

Conversation with the author.

**Rust, M., and J. Kennedy**

1993

The feasibility of using modified atmospheres to control insect pests in museums. Report, GCI Scientific Program, March.

**Valentín, N., and F. Preusser**

1990

Nitrogen for biodeterioration control on museum collections. In *Biodeterioration Research 3: Mycotoxins, Biotoxins, Wood Decay, Air Quality, Cultural Properties, General Biodeterioration, and Degradation*, ed. Gerald C. Llewellyn and Charles E. O'Rear. New York: Plenum Press.

**Valentín, N., M. Lindstrom, and F. Preusser**

1990

Microbial control by low oxygen and low relative humidity environments. *Studies in Conservation* 35:222-30.



# Protection of Objects from Environmental Deterioration by Reducing Their Exposure to Oxygen

Eric F. Hansen

Robert Feller has stated, "The deterioration of organic substances through their reaction with the practically unlimited supply of oxygen in the atmosphere is a fundamental consideration of preservation science" (Feller 1976:287). Technical advances, as described in chapter 1, make it practical to build museum cases that virtually exclude oxygen. Thus, objects that deteriorate in the presence of oxygen can be better preserved if displayed or stored in such cases.

This chapter discusses the effect of decreasing oxygen in the environments of artistic or historic works. It will be shown, for the primarily proteinaceous materials used in the examples, that reducing the amount of oxygen around them will diminish deterioration.

The past applications of low-oxygen environments in conservation are briefly reviewed here, followed by a discussion of the general effects of lowering oxygen concentration. Specific examples are presented to show the difficulties encountered in determining the beneficial effects for inhomogeneous and aged materials. This latter discussion emphasizes that individual factors must be independently considered for specific objects and collections. The requisite oxygen concentration, along with the relative humidity set point and allowable fluctuations, often represents a compromise rather than adherence to a strict, quotable number.

## Previous Applications

The most quoted early investigation of a low-oxygen environment for preservation purposes is the Russell and Abney Report of 1888 (Brommelle 1964), "Action of Light on Water Colors." There was concern over the fading of watercolor paintings in the South Kensington Museum and the National Gallery in London. Various light sources (sunlight, gaslight, and incandescent light) were available, but their individual effects on the fading of watercolors were not known. This situation provided the impetus for a study of the fading of artists' colors used at that time.

Russell and Abney concluded that the presence of moisture and oxygen was necessary for a change to occur, indicating that many colorants found in the watercolors they studied would fade less when exposed to light in vacuo. These findings prompted the design of an airtight vacuum container for oil paintings and watercolors, which was patented in 1893.

Kuhn (1968) demonstrated that improved protection for some light-sensitive artists' materials (dyes and pigments) could be attained by replacing air with nitrogen. A design was suggested for a museum case in which the concentration of oxygen is kept very low by maintaining a flow of nitrogen into it, thus creating a positive pressure. According to Kuhn, this method avoids many of the problems involved in the design of seals for a case in vacuo or with static control of a nitrogen atmosphere. It also allows humidification of the nitrogen, which is usually essential for organic materials. Kuhn also found that rates of fading decreased at lower levels of relative humidity and temperature, but not as dramatically as with the exclusion of oxygen.

In addition to the benefits of an anoxic environment for retarding the fading of colorants, there have been applications for parchment (collagen); paper (cellulose); and, to a much lesser extent, metals. The 1951 report of the National Bureau of Standards (NBS) on the required storage conditions for the Charters of Freedom of the United States (the Declaration of Independence and the Constitution) provides an important presentation of the benefits of an inert atmosphere for classes of objects whose cultural value warrants the extra expense involved in their preservation. This report was based in part on studies con-



ducted previously at the NBS on the effects of temperature and oxygen on the deterioration of leather (Kanagy 1940). The parchment documents were stored under an inert atmosphere of helium, humidified to 25% RH.

In addition to the Charters of Freedom, the handwritten preliminary copy, on paper, of Abraham Lincoln's Emancipation Proclamation is stored in a double-chambered glass-and-aluminum capsule under nitrogen (Preservation Capsule 1968), as are the twenty-nine sheets of the Constitution of Puerto Rico (Passaglia, Brown, and Dickens 1980). It has been reported that the linen Shroud of Turin (a cellulosic) is preserved rolled in silk, within a silver-bound reliquary in a nitrogen atmosphere (Weaver 1980). An inert-gas atmosphere has also been suggested, and implemented, for the storage of mummified remains of humans and animals (David 1986). This method was used for Egyptian mummies at the University of Turin but was found to be ineffective if the mummies already showed extensive signs of deterioration.

A low concentration of oxygen has also been suggested to preserve metals. Airtight Plexiglas cases filled with nitrogen (probably dry) have been used (Salins and France-Lanord 1943:26) to preserve iron plates from Merovingian belts. Nitrogen-filled display cases were designed for the Musée Archéologique of Strasbourg in an attempt to halt the noticeable deterioration of the iron in the Merovingian helmet from Baldheim (France-Lanord 1949). Much later, out of concern for their preservation, sections of the gilded bronze Gates of Paradise by Ghiberti were placed in Plexiglas containers filled with dry nitrogen in the Museo Opificio del Pietre Dure in Florence (Bulst 1986).

### **Deterioration in the Presence of Oxygen**

If the substance that makes up a museum object reacts with oxygen, the resulting oxidative chemical processes can cause physical changes, such as brittleness and cracking; as well as chemical changes, such as color fading (Feller 1977, 1994). Usually, however, museum objects are complex combinations of different substances. Further, because there are many kinds of deterioration besides those caused by oxygen, it is not always possible to predict precisely what protection from deterioration would be given to a particular object if it were placed in an inert-gas environment such as nitrogen. The chemistry of oxygen's reactions with several large classes of materials—cellulosics (paper, linen, cotton, and wood), proteins (parchment and vellum, skin of mummies), and colorants—is now sufficiently well known, however, to allow useful general predictions about how objects containing or composed of these materials will survive in nitrogen rather than in air.

Fairly pure cellulose, such as that found in acid-washed Whatman filter paper, is not affected by oxygen in the absence of light; the reactions are very slow at ambient temperatures (Zou et al. 1994; Heuser 1944:481, 487). However, ultraviolet radiation striking cellulose in oxygen degrades (breaks) some of the long chains of atoms that are found in cellulose and causes brittleness and loss of fiber strength, depending on the amount of ultraviolet exposure (Whitmore and Bogaard 1995) and on the concentration of oxygen in the environment (Stillings and Van Nostrand 1944). This photolytic oxidation of cellulose makes it more susceptible to later nonphotolytic degradation: test samples that have been exposed to ultraviolet, when heated in the dark in air in an 80 °C oven, degrade more rapidly than control samples that have never been irradiated. Therefore, degradation is probable over centuries in air at ordinary temperatures and humidities if an object containing cellulose has been exposed at some time to light rich in ultraviolet.

In summary, it is clear that removal of oxygen will hinder development of brittleness and loss of fiber strength in pure non-acidic cellulosics. This conclusion should not be generalized to all objects containing cellulose, such as paper, cotton, linen, or wood. For example, lower grade papers containing lignin—or a number of other substances introduced in processing—may be even more susceptible to light-induced damage, even in the absence of oxygen (Leary 1967). And, as is well known, the presence of very small amounts of acid in cellulose or cellulose objects, especially at high humidities, causes hydrolytic degradation and this process also leads to loss of strength in fibers. Therefore, a nitrogen atmosphere, though helpful in reducing oxidative damage, is not a universal cure for all modes of cellulose deterioration.

Proteins typically constitute parts of historic and of art objects. Collagen is the principal protein of the skin of mummies and of animal skins, and thus is the major substituent of parchment (from goats and sheep) and of vellum (from lambs, kids, and calves). Sobel and coworkers (1968) have shown that collagen reacts slowly with oxygen to form a variety of compounds; Sobel and Hansen (1989) have extended this work to suggest that the amount of change in a protein could be roughly related to its age.

Obviously, then, an oxygen-free environment would preserve proteinaceous materials such as parchment and mummified remains by greatly reducing their rates of deterioration by oxygen. Insofar as similar changes arising from reaction with oxygen are reported in the proteins of silk (fibroin and sericin), objects containing these materials could also be better preserved by placement in oxygen-free environments (Hansen and Sobel 1994).

Colorants—dyes and pigments in watercolors—have been mentioned in this chapter as subjects of the earliest studies related to conservation using a reduced-oxygen environment. Organic dyes show a great range of fading behavior under the influence of light; those most prone to fading are almost as fugitive in sunlight as the term suggests. The rate of fading of many dyes in nitrogen atmospheres decreased even faster than the oxygen level decreased at lower and lower oxygen concentrations (Arney, Jacobs, and Newman 1979). However, this determination of the increase in life expectancy of many colorants in nitrogen was accompanied by the warning that a minority of colorants are reported to fade *more* rapidly in the absence of oxygen than in its presence.

A similar caution has been challenged: Kenjo (1980) stated that sienna (which contains iron oxide) and litharge (a lead oxide) fade in low-oxygen conditions, but Koestler and coworkers (1993) determined more recently that no such fading in nitrogen was observable by two skilled paintings conservators. Kenjo also reported that red vermilion (mercuric sulfide) darkened when oxygen was removed in his fading tests. However, this is undoubtedly the result of mercuric sulfide's well-known crystal-structure change to black cinnabarite under the influence of bright light, not an effect of lack of oxygen (Feller 1967).

## Case Studies

### Parchment

Parchment is a writing material whose distinctive characteristics are produced by drying dehaired animal skin under tension. Its major constituent is insoluble collagen, which constitutes about 95% of defatted, dehaired skin.

Atmospheric oxygen reacts with collagen over time, causing cross-linking or chemical modification of several amino acids in the protein chains (Sobel and Hansen 1989). The changes resulting from oxidation depend on the way the

parchment was processed, as well as on the residual fats and also the type and amount of additives, such as softening agents.

In 1951, the National Bureau of Standards reported its conclusions on "the best means of preserving the original copies of the Declaration of Independence and the Constitution of the United States" in response to a request from the Library of Congress (NBS 1951). They recognized that an inert gas would eliminate destructive components in the atmosphere, oxygen in particular. Further, the presence of either too much or too little moisture could contribute to the deterioration of parchment. Finally, a suitable filter should be found that would eliminate the damaging effects of light radiation. Based on a number of studies of the stability of collagen and leather (also processed from skin), they suggested using a display case containing a helium atmosphere humidified to a relative humidity of 25%. A laminated plastic-and-glass wall would filter out both the ultraviolet and some of the blue light. The Charters of Freedom were later examined by a panel of scientists and conservators in 1982 without being removed from the case (Calmes 1985). No evidence of deterioration beyond that observed at the time of encasement could be documented through comparison of photographs.

In a subsequent study, Sobel and Ajie (1992) extracted fragments of Dead Sea Scroll parchments for collagen and subjected the extracts to amino acid analysis by high-performance liquid chromatography. In modern parchment samples, 90% or more of the protein could be extracted in hot aqueous solution. In contrast, because of oxidative cross-linking in ancient specimens, only 70% or less was extractable. When the soluble extracts were analyzed, the quantities of tyrosine, histidine, and methionine were found to be reduced in the extracts from ancient parchment. In addition, an oxidation product of tyrosine, di-tyrosine, was detected. Because these amino acids are those that are expected to be affected by oxygen, Sobel and Ajie concluded that "they seem to be reduced . . . as a result of an oxygen effect."

Further studies were conducted by the GCI to support recommendations to the Israel Museum on the optimum environmental conditions for the display and storage of the Dead Sea Scrolls. The effects of relative humidity were considered in addition to those of atmospheric oxygen. Hansen and coworkers (1992) investigated the effects of various relative humidities on some physical properties of calfskin parchment (vellum). Standard samples were subjected to tensile testing after equilibration at various relative humidities between 11 % and 60%. In further tests, samples were restrained at a specific length, and the force that developed in them was measured as the relative humidity was lowered.

Brittleness was observed below 11 % RH, and it was found that about 25% RH was the lowest relative humidity that could be tolerated without inducing large stresses in the material. Based on these results, the gelatination that may be promoted at humidity levels above 40%, and the biodeterioration of parchment at higher humidity levels (Valentín, Lindstrom, and Preusser 1990), Hansen and coworkers (1992) suggested a relative humidity of 30% for the optimum environment of objects derived from skin. These conclusions do not differ significantly from those proposed by the NBS in 1951 for the Charters of Freedom.

Another very important consideration is the extent of deterioration of an object that is ancient, such as the two-thousand-year-old Dead Sea Scrolls. Several studies have indicated that much of the collagen in the Dead Sea Scrolls has been altered (Burton, Poole, and Reed 1959; Derrick 1992; Weiner et al. 1980). Because of the particular cultural importance of such objects as the scrolls, factors providing the longest-term durability (relative humidities lower than 50%) may outweigh immediate aesthetic effects. These include possible curling or curvature of a document (Schilling and Ginell 1993), along with the extra care in

handling that is needed for a more brittle material. Thus, in addition to the exclusion of oxygen, the provision of a stable relative humidity above 25% RH and below 40% RH appears desirable.

Other considerations have not been fully studied, however, particularly the effects of relative humidity on the physical stability or adhesion to the parchment substrate of inks or colorants present in painted parchment manuscripts. Recommendations for a relative humidity of 50% or higher may be suitable for a particular situation in which pliability or other physical properties of parchment are the main concerns, rather than very long-term physical and chemical stability.

### **The royal mummies at the Egyptian Museum**

The mummification procedure in ancient Egypt changed over the centuries. Therefore, a general perspective needed to be adopted to determine suitable environmental conditions for the royal mummies at the Egyptian Museum in Cairo. A primary factor in the present state of preservation of the mummified remains of the pharaohs is the original success of the mummification process. Although a mummy may be wrapped and/or stuffed with linen or cotton and coated with resins, the object consists mainly of the intentionally desiccated remains of a human body; and conditions that are optimal for proteinaceous materials (such as collagen in skin, keratin in hair, etc.) are given the greatest consideration.

The most important function of an inert atmosphere for the royal mummies is the suppression of biological activity, particularly because no other desirable fumigant or sterilant system has been proposed or shown to be successful (see the discussion of gamma-ray exposure in chapter 3, page 17). Furthermore, because of the collagen and other proteinaceous materials present that will be modified by oxygen over time, an inert atmosphere is also desirable for the same reasons given for parchment.

The preservation of mummified material is highly dependent on the successful removal of moisture before deterioration becomes pronounced. Thus, rehydration of mummies should be avoided because higher relative humidities promote not only gelatination but also hydrolysis, which results in a reduction of the molecular weight of proteins. Barraco (1977) found such a change in molecular weight in protein extracted from the tissues of an Egyptian mummy (Nakht Rom I) by comparison with protein from freshly autopsied human skeletal muscle.

Hansen (1989) found that the water-absorption curves of samples from a variety of Egyptian mummy tissues (skin and skeletal muscle) were similar to the water-absorption curves of modern parchment. The percentage water uptake was the same after exposure to a higher relative humidity following equilibration at a lower relative humidity. In addition, the force developing in mummified skin at a restrained gauge length was similar to that in modern parchment when the relative humidity was lowered. The partially rehydrated mummified tissue developed a large force of contraction when exposed to relative humidities below 20%. These data, although restricted to a few samples of mummified tissue from a single historical time period, support a relative humidity recommendation for mummified human remains similar to that for parchment.

### **Conclusion**

Although the majority of studies in the field of conservation involving an essentially oxygen-free environment have focused on the reduction of fading rates of colorants, implications also exist for museum cases designed to display impor-

tant written documents on paper and parchment, and a variety of proteinaceous objects. The Charters of Freedom of the United States of America, the Constitution of India, and mummified human remains such as those in the Royal Mummy Collection of the Cairo Museum are prime examples.

Oxygen reacts with parchment (made from animal skin) and with some of the materials present in mummies over long periods of time; it changes their chemical composition and, subsequently, their physical properties. Thus, the preservation of these objects is aided by excluding oxygen from museum cases in which they are displayed or stored.

The chemical complexity of aged natural products does not allow a specific "number" or quantifiable oxygen concentration to be stated for optimum preservation of these objects. However, a reduction of the oxygen concentration to the lowest that can be achieved, preferably below 1000 ppm, is the most prudent course.

In the specific case of materials containing collagen, a range of 25-40% RH has been suggested. Below this level, the chemical and physical stability of collagen is affected. The desirable set point of relative humidity above 25% depends on whether conditions are intended for long-term storage or for short-term handling or display.

## References

Arney, J. S., A. J. Jacobs, and R. Newman

1979

The influence of oxygen on the fading of organic colorants. *Journal of the American Institute for Conservation* 18:108-17.

Barraco, R. A.

1977

Analysis of protein extract. *CMA Journal* 117:474.

Brommelle, N. S.

1964

The Russell and Abney Report on the action of light on watercolors. *Studies in Conservation* 9(4):140-51.

Bulst, W. A.

1986

Ausstellungen: L'oro del Ghiberti. Restauri alia porta del Paradiso, Florenz, 7. Dezember 1985-2. Februar 1986. [Exhibitions: Ghiberti's gold. Restorations on the door of Paradise, Florence, 7 December 1985-2 February 1986.] *Kunstchronik* 39(4): 125-26.

Burton, D. M. B. E., J. B. Poole, and R. Reed

1959

A new approach to the dating of the Dead Sea Scrolls. *Nature* 164:533-34.

Calmes, A.

1985

Charters of Freedom of the United States. *Museum* 146:99-101.

David, A. E.

1986

Conservation of mummified Egyptian remains. In *Science in Egyptology*. Manchester, England: Manchester University Press.

Derrick, M.

1992

Evaluation of the state of degradation of Dead Sea Scroll samples using FT-IR spectroscopy. *American Institute for Conservation Book and Paper Group Annual* 10:49-65.

Feller, Robert L.

1967

Studies on the darkening of vermilion by light. In *Report and Studies in the History of Art 1967*, 99-111. Washington, D.C.: National Gallery of Art.

1976

The deterioration of organic substances and the analysis of paints and varnishes. In *Preservation and Conservation: Principles and Practices*, ed. Sharon Timmons, 287-99. Washington, D.C.: Smithsonian Institution Press.

1977

Stages in the deterioration of organic materials. In *Preservation of Paper and Textiles of Historic and Artistic Value*, ed. J. C. Williams, 314-35. Advances in Chemistry Series, no. 164. Washington, D.C.: American Chemical Society.

1994

*Accelerated Aging: Photochemical and Thermal Aspects*. Marina del Key, Calif.: Getty Conservation Institute.

France-Lanord, A.

1949

La conservation du casque Merovingien de Baldheim. *Cahiers d'Archeologie et d'Histoire d'Alsace* 130:277-80.

Hansen, E. F.

1989

Initial recommendations for the display conditions of the Royal Mummies of the Cairo Museum. Internal report, Getty Conservation Institute, Marina del Key, Calif.

Hansen, E. F., S. N. Lee, and H. Sobel

1992

The effects of relative humidity on some physical properties of modern vellum: Implications for the optimum relative humidity for the display and storage of parchment. *Journal of the American Institute for Conservation* 31(3):325-42.

Hansen, E. F., and H. Sobel

1994

The deterioration and preservation of silk. *The Textile Specialty Group Postprints, American Institute for Conservation 20th Annual Meeting, Buffalo, New York, June 1992*, 14-30. Washington, D.C.: AIC.

Heuser, Emil

1944

*The Chemistry of Cellulose*. New York: John Wiley and Sons.

Kanagy, J. R.

1940

Effect of oxygen concentration and moisture on the stability of leather at elevated temperatures. *Journal of Research of the National Bureau of Standards* 25:149.

**Kenjo, T.**

1980

Studies on the long-term conservation of cultural properties (part 1). 2. Effects of different concentrations of oxygen on pigments used for cultural properties. *Scientific Papers on Japanese Antiquities and Art Crafts* 25:103-07.

**Koestler, R., E. Parreira, E. Santoro, and P. Noble**

1993

Visual effects of selected biocides on easel painting materials. *Studies in Conservation* 38:265-73.

**Kuhn, Herman**

1968

The effect of oxygen, relative humidity and temperature on the fading rate of watercolours. Reduced light damage in a nitrogen atmosphere. In *Contributions to the London Conference on Museum Climatology, 18-23 September 1967*, ed. Garry Thomson, 79-85. London: International Institute for Conservation of Historic and Artistic Works.

**Leary, G. J.**

1967

The yellowing of wood by light. *TAPPI* 50(1):17-19.

**National Bureau of Standards (NBS)**

1951

*Circular 505, Preservation of the Declaration of Independence and the Constitution of the United States*. Washington, D.C.: NBS.

**Passaglia, E., D. Brown, and Brian Dickens**

1980

*The Preservation of the Constitution of Puerto Rico*. Washington, D.C.: NBS.

**Preservation Capsule**

1968

*Manuscripts* 20(2):56-60.

**Salins, E., and A. France-Lanord**

1943

*Le Fer à l'Epoque Merovingienne*. Paris: Librairie Orientaliste Paul Geuthner.

**Schilling, M. R., and W. S. Ginell**

1993

The effects of relative humidity changes on Dead Sea Scrolls parchment samples. In *ICOM Committee for Conservation 10th Triennial Meeting, Washington, D.C., USA, 22-27 August 1993, Preprints*, vol. 1, ed. J. Bridgland and J. Hill, 50-56. Paris: ICOM Committee for Conservation.

**Sobel, H., and H. Ajie**

1992

Modification of amino acids of Dead Sea Scroll parchments. *Free Radical Biology and Medicine* 13:701-2.

**Sobel, H., and E. F. Hansen**

1989

Environmentally produced changes in historic proteins. A: Collagen. Text of a poster presented at the Third Annual Symposium of the Protein Society, Seattle, Wash.

**Sobel, H., M. J. Hewlett, F. Hariri, and R. S. Pogrund**  
1968

Skin composition following exposure of mice to a hyperbaric oxygen-nitrogen mixture. *Proceedings of the Society for Experimental Biology and Medicine* 129: 89-91.

**Stillings, R. A., and R. J. Van Nostrand**  
1944

The action of ultraviolet light upon cellulose: I. Irradiation effects. II. Post-irradiation effects. *Journal of the American Chemical Society* 66:753-60.

**Valentín, N., M. Lindstrom, and F. Preusser**  
1990

Microbial control by low oxygen and low relative humidity environment. *Studies in Conservation* 35:222-30.

**Weaver, K. F.**  
1980

The mystery of the shroud. *National Geographic* 157(6):730-53.

**Weiner, S., Z. Kustanovish, E. Gil-Av, and W. Traub**  
1980

Dead Sea Scroll parchments: Unfolding of the collagen molecules and racemization of aspartic acid. *Nature* 287:820-24.

**Whitmore, P. M., and J. Bogaard**  
1995

The effect of oxidation on the subsequent oven aging of filter paper. *Restaurator* 16:10-30.

**Zou, X., N. Gurnagul, T. Uesaka, and J. Bouchard**  
1994

Accelerated aging of papers of pure cellulose: mechanism of cellulose degradation and paper embrittlement. *Polymer Degradation and Stability* 43:393-402.





# Preservation of Historic Materials by Using Inert Gases for Biodeterioration Control

Nieves Valentín

This chapter is concerned with solving two problems related to biodeterioration: insect infestation and the growth of microorganisms. Either can be devastating to historic or prized objects. Both can be counteracted by the use of an inert gas such as nitrogen or argon and control of the relative humidity.

For many years, grains and other food products have been protected from insects and rodents by storing them in low-oxygen environments, primarily nitrogen (Bailey and Banks 1980:101-18; Nakamura and Hoshino 1983; Navarro and Jay 1987; Fleurat-Lessard 1990; Donahaye 1990; Smith and Newton 1991). Nitrogen does not kill insects directly; it simply prevents an undesirable pest from obtaining the oxygen it needs for continued life. Thus, nitrogen anoxia does not kill as rapidly as the toxic gases that have conventionally been used. However, the common fumigants for treating art and cultural objects have been methyl bromide, ethylene oxide, and Vikane (sulfuryl fluoride). Each of these poses serious threats to the collections being treated, as well as creating potential hazards for the conservators responsible for the procedure (Florian 1988). Fungal and bacterial attacks on historic objects can result in unsightly blotches ranging from whitish through green or reddish brown to black, as well as actual destruction of the fine structures of their surfaces. Older methods of killing fungi or bacteria with solutions of toxic cresols (ortophenyl phenol and sodium salt, pentachlorophenol and sodium salt p-chloro-m-cresol, and thymol) or tetralkyl-ammonium salts are now in disfavor for clear reasons of possible harm to the objects as well as to the conservators. Delicate vacuuming of the affected area to remove the "bloom" of fungus and the application of alcohol are a preferred procedure, although, because the alcohol evaporates relatively rapidly, the transient nature of its protection is a disadvantage. Gamma radiation has also been used for sterilization of cultural objects, such as paper and mummies (Pääbo, Gifford, and Wilson 1988; Hutchinson 1985), but it can harm the materials being treated, requires truly expert supervision for safety and effectiveness, and is costly.

Although nitrogen had been employed in conservation for various purposes, its use for insect disinfection was not widespread at the time of the author's initial work in 1987 (Valentín 1989). There is good evidence that a nitrogen atmosphere retards the fading of many watercolors and organic colors subject to oxidation (Valentín, Algueró, and Martín de Hijas 1992; Koestler et al. 1993; see chapter 2 for references to the minority of colors that fade in nitrogen, and the correction to Kenjo 1980).

In 1987, a research program whose goal was preventive conservation of oxygen-sensitive museum objects from biodeterioration was begun at the Getty Conservation Institute, using the low-oxygen environments of nitrogen atmospheres. From 1989 to the present, this research has continued at the Instituto del Patrimonio Histórico Español (formerly the Instituto de Conservación y Restauración de Bienes Culturales [ICRBC]). It was intended to investigate (1) killing insects already present or those that would invade in the future and (2) controlling microbiological activity such as that of bacteria or fungi.

## The Elimination of Insect Infestation in Museum Objects

The damage that can be inflicted on museum or library objects by insects is almost as well known to the public as it is to conservators. Any householder with woolen clothing knows how the feeding habits of clothes moths can ruin the appearance of a garment, just as individuals in warm climates are familiar with the equally ubiquitous termites and their attacks on house structures. Most private owners of collections of historic books have seen holes in paper and parchment pages or evidence of attacks on leather bindings by insects. Of course, the problem for a museum, with its unique objects, is far more serious. The depredation

tions of insects must be halted, not merely controlled, for the preservation of cultural treasures for future generations.

Initial experiments in attacking this serious problem were designed to determine the efficacy of low-oxygen nitrogen atmospheres in killing a well-studied insect, *Drosophila melanogaster*, and then to conduct a practical test by placing an infested museum object in nitrogen under controlled environmental conditions. For the *Drosophila* work, a large number of all of the insect's life forms—eggs, larvae, pupae, and adults—were subjected to various combinations of temperature, RH, and length of exposure. Results showed complete insect mortality after 80 hours at 25 °C, 75% RH, and 0.5% oxygen (99.5% nitrogen). Afterward, a polychrome picture frame that was being actively attacked by *Cryptotermes brevis* was successfully disinfested by exposure for fifteen days in the same nitrogen atmosphere (0.5% oxygen) at 22 °C and 50% RH (Valentín and Preusser 1990).

Rust and Kennedy (1993) reported their in-depth entomological studies of nitrogen anoxia, which were carried out under the sponsorship of the GCI. They examined a large sample population of all of the life forms of the ten species of insects that are considered to be the most common museum pests in the United States and Canada. Using nitrogen-filled test chambers in which the oxygen content was rigorously controlled at less than 0.1 %, they found that only 72 hours at 25.5 °C and 55% RH were required for a complete kill of most developmental stages of most species. However, 192 hours (eight days) were required for total mortality of all egg forms of *Lasioderma serricorne* (cigarette beetle). Therefore, a minimal exposure of ten days in a 0.1 % oxygen-containing nitrogen atmosphere (and 25 °C, 55% RH) is conservatively advisable to achieve total insect anoxia in museum objects.

Conservators at other institutions have reported the success of nitrogen atmospheres in eradicating insects in historic objects (Gilberg 1991; Hanlon et al. 1993; Koestler 1992). After beginning work at the GCI, the author continued these investigations at the ICRBC in Spain. Extensive evaluations were concluded for eight different species of insects in all stages, using not only nitrogen atmospheres but argon and carbon dioxide (Valentín 1993) in widely varied types of fumigation containers. Carbon dioxide was ineffective in eliminating the species in the Cerambycidae, Anobiidae, Dermestidae, and Lyctidae; this would make it suspect for use in treating any infested objects without a detailed entomological examination to determine what insects were present. It was further established (Fig. 3.1) that for *Anobium punctatum* (furniture beetle), *Attagenus piceus*, *Hylotrupes bajulus* (house longhorn beetle), *Lasioderma serricorne*, *Lyctus brunneus*, *Nicobium castaneum*, and *Stegobium paniceum* (drugstore beetle), a shorter exposure time was required for complete mortality in argon than in nitrogen. However, using argon at shorter exposure times than used with nitrogen to kill insects in a museum piece would be unwise without expert entomological evaluation of the infesting species, a requirement that may be impossible for some museums to meet and tedious for others. An important finding in the work was that an increase in temperature in the anoxia container or chamber from 20 °C to 30 °C resulted in a marked decrease in the time required for complete mortality.

Anoxia of *Hylotrupes bajulus*, *Lasioderma serricorne*, and *Anobium punctatum* at 40 °C required only one day in both argon and nitrogen, whereas at 20 °C, the time required for anoxia of these three species in argon and nitrogen were, respectively, nineteen, eight, and six days; and nineteen, ten, and eight days (Fig. 3.2). It is clear that a high temperature such as 40 °C may be inadvisable for some museum objects. Nevertheless, for plant species collected from expeditions, such high temperatures are not only tolerable but useful in aiding their

Figure 3.1

Effect of temperature on the exposure time required to achieve a complete insect mortality at 40% RH and low-oxygen concentration in nitrogen and argon atmospheres (<0.1%) shown for (1) *Hylotrupes bajulus*, (2) *Lasioderma serricorne*, (3) *Anobium punctatum*, (4) *Xestobium rufovillosum*, (5) *Lyctus brunneus*, (6) *Stegobium paniceum*, (7) *Nicobium castaneum*, and (8) *Attagenus piceus*.

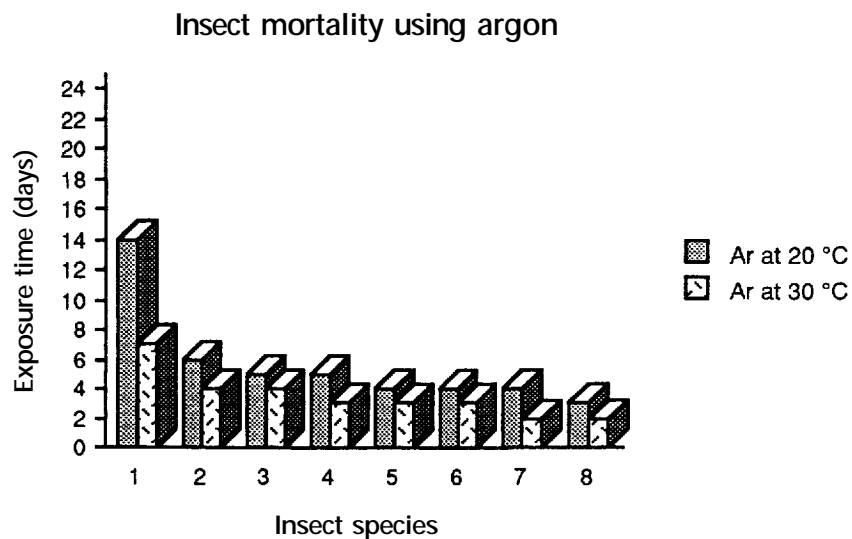
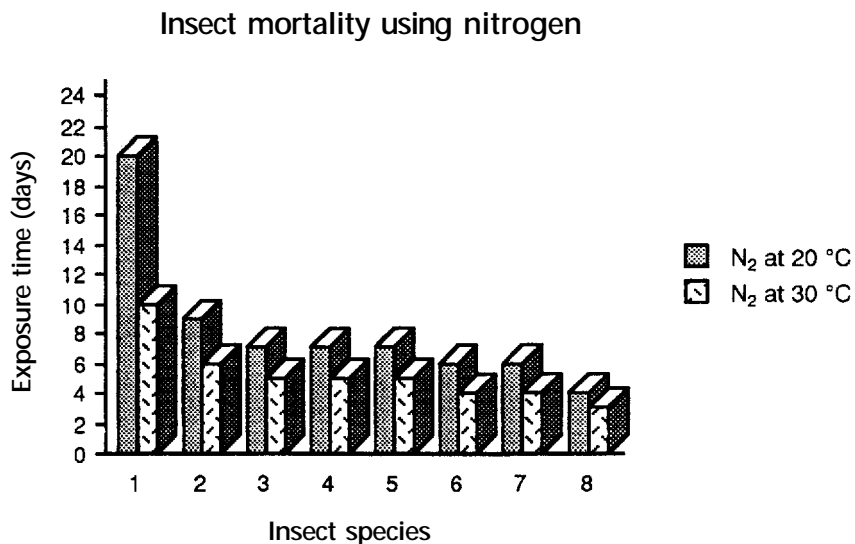

drying prior to storage. No physicochemical alterations, including color changes on petals, were found in plants treated at 35-40 °C for five days (Valentín, Algueró, and Martín de Hijas 1992). Thus, disinfestation and initial drying can be carried out in one step under a nitrogen flow through an oven at 40 °C.

### The Control of Fungal and Bacterial Growth on Museum Objects

Proteinaceous materials such as parchment, leather, and mummified tissues are highly susceptible to aerobic fungal and bacterial and anaerobic bacterial growth. Aerobic bacteria can damage both the surfaces and the lower layers of these materials with unpleasant stains, as do fungi with their visually disagreeable blotches of white, green, or dark-colored colonies that resemble efflorescence. Anaerobic bacteria produce proteolytic enzymes, which cause collagen depolymerization and thus loss of an object's strength and even its integrity. Anaerobic fungi are very infrequent in organic objects (Kowalik 1980). There-

Figure 3.2

Effects of high temperature and argon and nitrogen atmospheres on the exposure time required to eradicate *Lasioderma serricorne* in herbaria collections. *Hylotrupes bajulus* and *Anobium punctatum* were used as models.

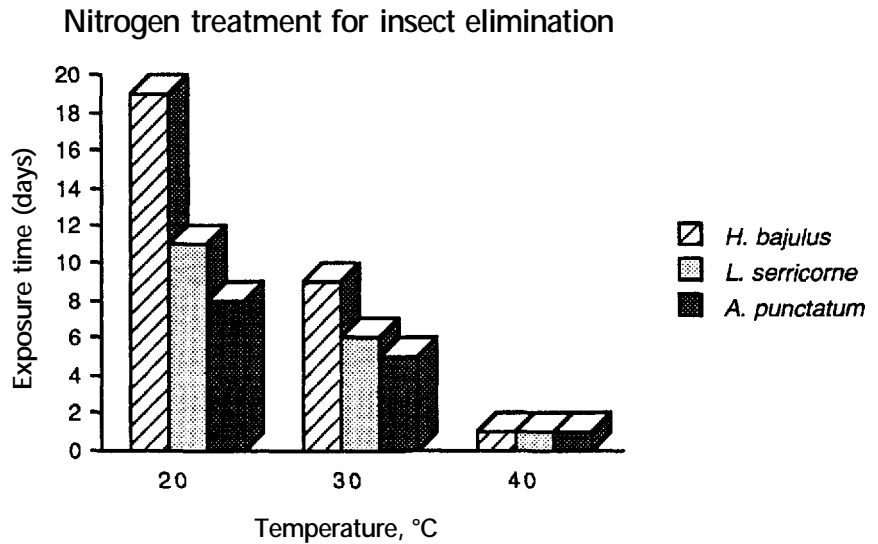
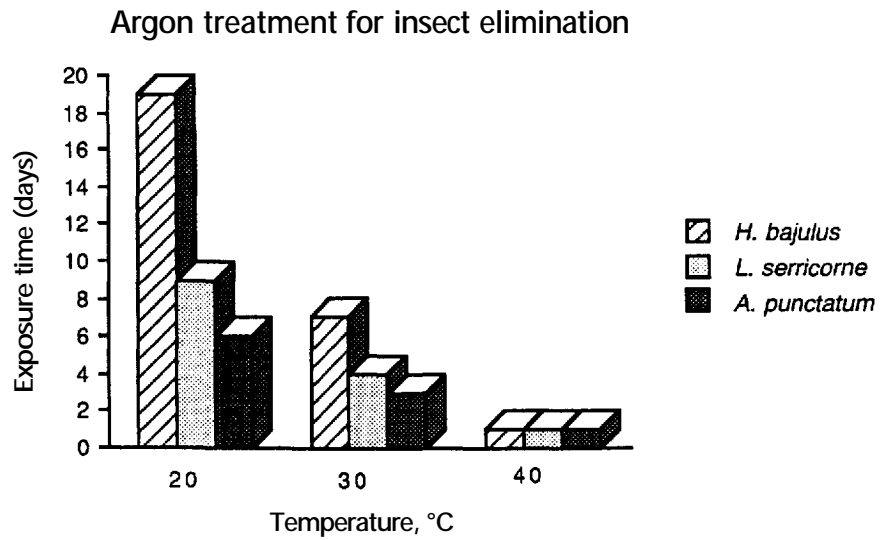

fore, the second objective of the GCI program that was begun in 1987 was evaluation of the influence of RH and low-oxygen atmospheres on bacterial growth, including anaerobes. The general procedures and conclusions are given in the following sections.

#### Aerobic organisms

To find the effect of RH and low-oxygen atmospheres on fungal and bacterial growth, samples of microorganisms were isolated from the skin of a three-thousand-year-old mummy of an adult female that had been loaned to the GCI by the Egyptian Antiquities Organization (EAO). Most microorganisms (Fig. 3.3) corresponded to *Aspergillus niger*, *Aspergillus flavus*, *Penicillium commune*, *Actinomyces sp.*, *Bacillus sp.*, and *Streptomyces sp.*, but anaerobic types were also found and taken for testing.

Figure 3.3

Fungal and bacterial contaminants isolated from a three-thousand-year-old Egyptian mummy of an adult female, treated with natron.

### Contamination in Egyptian mummy (adult)

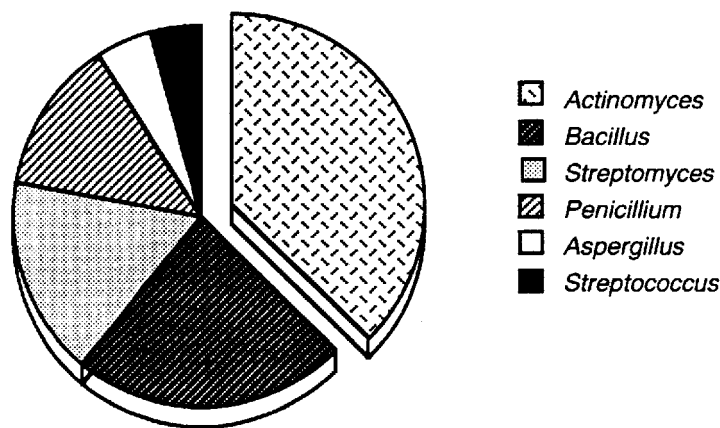

The microbial samples were inoculated on clean parchment strips and exposed to various combinations of RH (33%, 43%, 50%, 75%, 85%, and 100%) and oxygen concentrations (0.1%, 1%, 5%, and 20%) in nitrogen atmospheres. Their growth rate was monitored by determining the radioactivity in the carbon dioxide produced after about three days by the heterogeneous population of fungi and bacteria growing on the parchment strips in the presence of C-14-containing sodium lactate or succinate.

The biological activity of the microorganisms was retarded remarkably when the oxygen level was 1% or less and the RH was lower than 50%. As shown in Figure 3.4, if the oxygen present in the nitrogen atmosphere was only 0.1%, even at 50% RH there was essentially no increase in the amount of radioactive carbon dioxide produced after about three days; that is, the number of microorganisms was unchanged from that time on. In fact, after only 10 hours of exposure to 45% RH at the lowest oxygen level, this inhibition of growth was notable and was moving toward stabilization of the size of the colonies, a significant control of biological activity.

It is not novel to find that lower-RH environments hinder the growth of microorganisms. Common fungi, including those cellulolytic species that are harmful to paper and wooden museum objects, need an RH of over 80% for significant growth (Gallo 1992). Only the xerophilic fungi, far rarer in cellulose or proteinaceous materials, can grow at 65% RH. Normal bacteria also require very high RH, about 90%, to grow best, with halophilic bacteria a notable exception at 75% RH. Common yeasts multiply well at 88% RH. The lowest RH that is tolerated for optimal microbial growth, 60%, has been reported for the *Saccharomyces rouxii* yeast. However, the conservator should not conclude that simply keeping objects in a display case at a given RH will insure inhibition of the growth of harmful microorganisms. The hygroscopicity of the object's material(s) and the specific moisture content of the support, and the surrounding environmental conditions, can contribute to the RH immediately at the surface of an object and thus affect the microbial growth rate. However, the fact that a combination of a low-oxygen concentration in nitrogen atmospheres with comparatively low RH completely stops the growth of microorganism colonies is an important finding of this study (Fig. 3.5).

#### Anaerobic organisms

This phase of the research involved the use of small skin fragments from mummified remains, acquired from various museums in Spain, as well as noninvasive samples obtained from an Egyptian mummy then being studied at the GCI. A

Figure 3.4

Effects of various relative humidities and oxygen concentrations on the biological activity of a heterogeneous population of micro-organisms inoculated on parchment samples and incubated for four weeks.

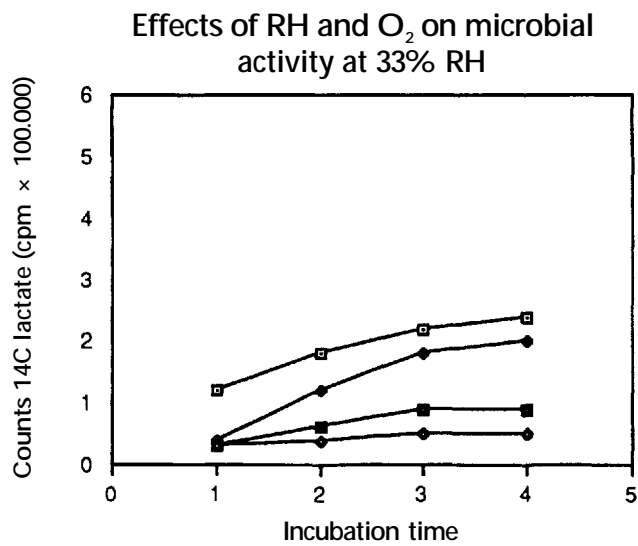
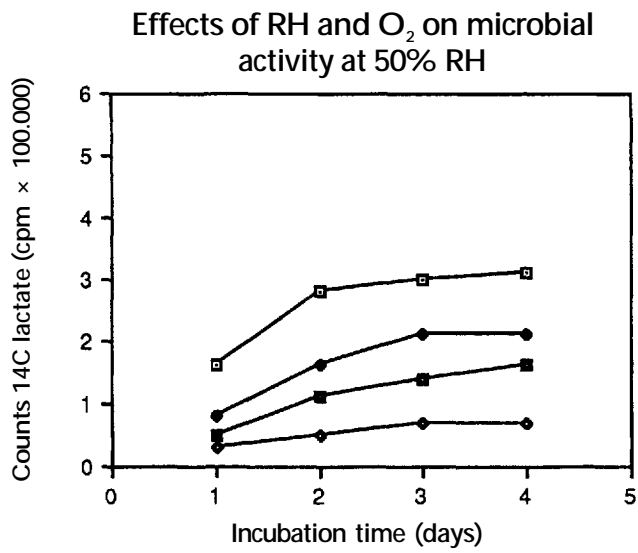
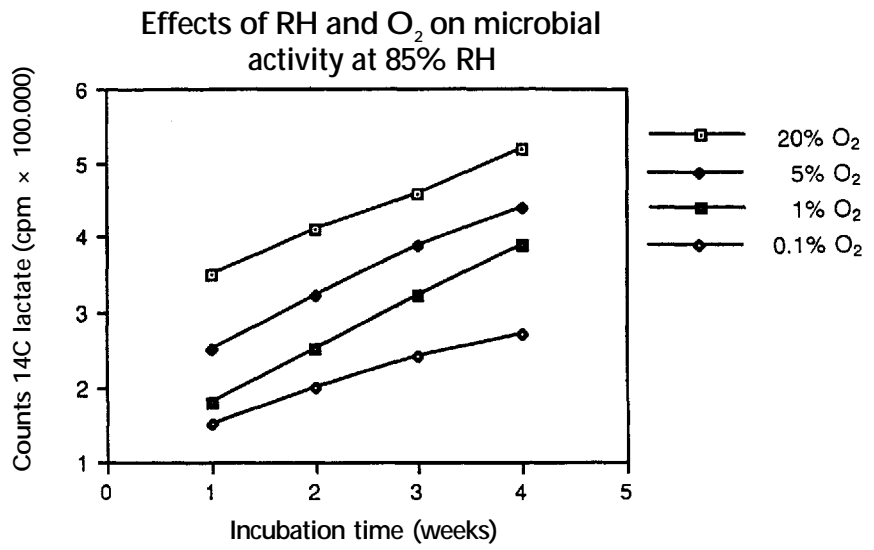
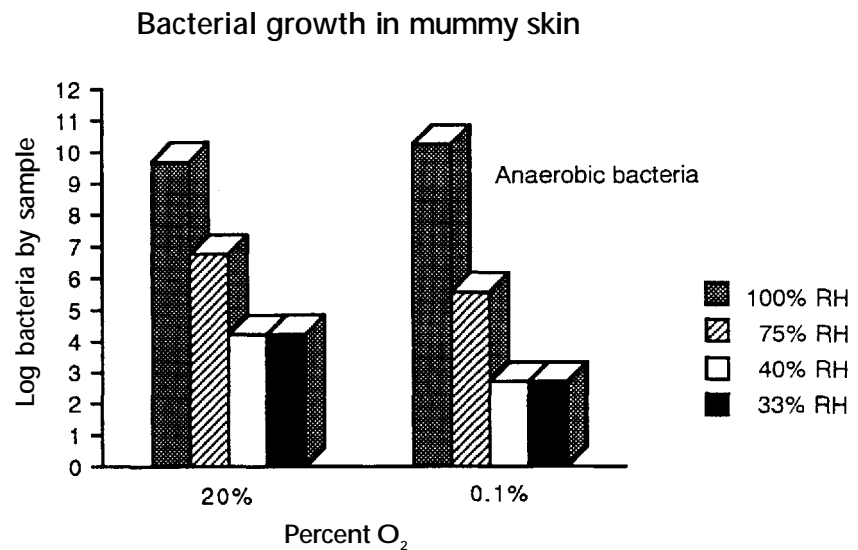

Figure 3.5

Bacterial growth in mummy skin exposed to various relative humidities and oxygen concentration for nine weeks.



rapid method involving epifluorescence microscopy was employed to detect increases in anaerobic as well as aerobic bacterial growth (Valentín 1990).

The procedure required a totally particulate-free solution of the fluorescent dye acridine orange. This was obtained by passing the dissolved dye (250 mg per liter of deionized water) through a cellulose nitrate nucleopore membrane. Then the possibly contaminated proteinaceous materials that had been exposed to different RH conditions (33%, 40%, 75%, and 100%) at oxygen levels of 1% and 20% were treated with the stain. The DMA and RNA of any viable or non-viable microbial cells on the sample fragments were characterized by their fluorescence under epifluorescence microscopy. Both aerobes and anaerobes were detected, and evaluation of their growth was made.

Even after nine weeks, there was high bacterial growth in samples that were exposed to RH greater than 70%, despite the presence of only 0.1% oxygen in the nitrogen atmosphere, a clear indication of the presence of anaerobes. However, just as with aerobic microorganisms, essentially zero growth of colonies occurred when the RH was in the 33-40% range and the oxygen content of the nitrogen atmosphere was 0.1%. It should be emphasized that it has been demonstrated that exposure of proteinaceous materials to low humidities (in the 30-40% range) prevents significant alterations in the physico-chemical properties (Petushkova and Nikolaev 1983; Hansen, Lee, and Sobel 1992; see chapter 2).

### Inert Gases for the Biodeterioration Control of Mummified Remains: A Case Study Background

#### The conservation of a contaminated mummy

To demonstrate the disinfection process that would involve both an inert gas with low oxygen content and a low RH, an Egyptian mummy of a five-year-old child (Fig. 3.6) was selected for the treatment. The mummy had been on display at the Biblioteca-Museu Victor Balaguer in Vilanova i la Geltrú, Spain, since 1886, first in a succession of two wood-framed glass cases and then, from 1988 to 1992, in a marble-based unit whose glass superstructure was framed in metal. Elegant as it was, it was far too leaky and thus allowed spores as well as considerable dust to enter. Further, the fluorescent light in its top was too intense and caused photooxidation of cellulosic material close to it. The mummy, which had rested on a cushion that retained moisture and dust, showed the visible presence of fungus mycelia and stains produced by bacteria (Fig. 3.7). The mummy was



Figure 3.6

Egyptian mummy of a five-year-old child on display at the Biblioteca-Museu Victor Balaguer in Vilanova i la Geltrú, Spain. The mummy was treated with an argon atmosphere.



wrapped and covered with polychrome papyri. The wraps showed high microbial contamination and insect infestation, augmented by the condensation problems of the display case, where it had been exhibited for four years. Microorganisms that were isolated from the mummy, as shown in Figure 3.8, included *Penicillium*, *Aspergillus*, *Ulodadium*, *Stachybotrys*, *Bacillus*, *Streptococcus*, *Actinomyces*, *Mucor*, and *Streptomyces*. Dermestidae insects were found in the mummy's head.

To control microbial growth and insect infestation, the mummy was laid on a perforated acrylic support to allow atmospheric circulation around the body. The mummy and support (Fig. 3.9) were then placed in a bag fabricated from a plastic that had a very low oxygen permeability (Fig. 3.10). Argon, humidified to an RH of 40%, was purged to flow through the bag at the rate of one liter per minute for six months to maintain the low-oxygen environment. Microbial analyses were conducted throughout the treatment period. The comparative results shown in Figure 3.11 indicate a decrease in fungal and bacterial growth after only five weeks of using this dynamic flow system of inert gas treatment at 40% RH. At the end of a two-year period in argon, the mummy was installed in

Figure 3.7

Microbial contamination due to fungus mycelia and stains produced by bacteria on the underside of the mummy shown in Fig. 3.6.

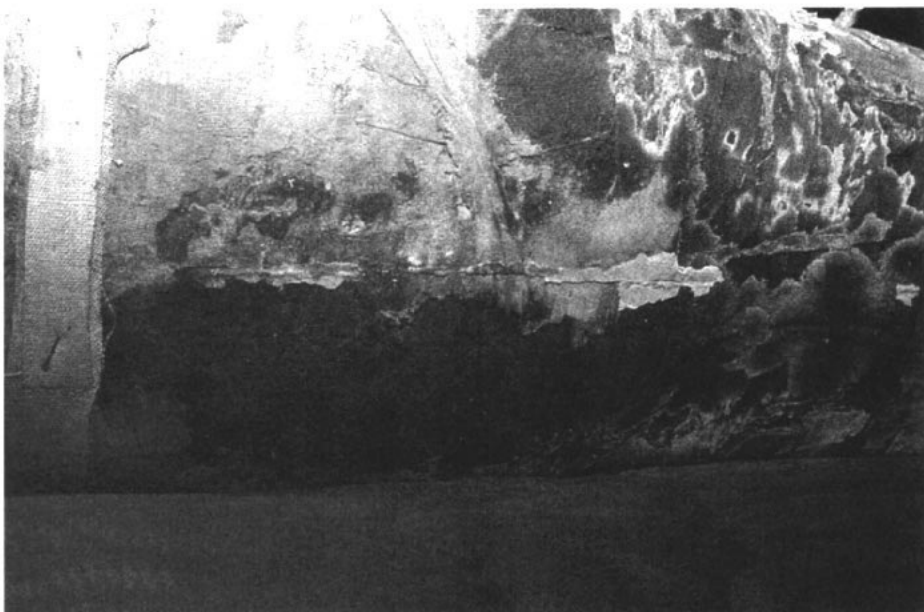

Figure 3.8

Chart showing relative proportions of fungal and bacterial contaminants isolated from the wrapping of the Egyptian mummy of a child shown in Fig. 3.6.

### Contamination in Egyptian mummy (child)

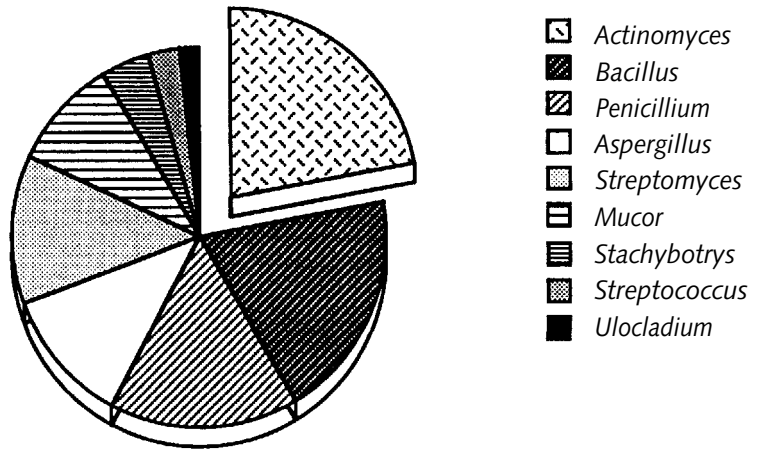

Figure 3.9

Perforated Plexiglas support for the mummy used during the argon treatment.

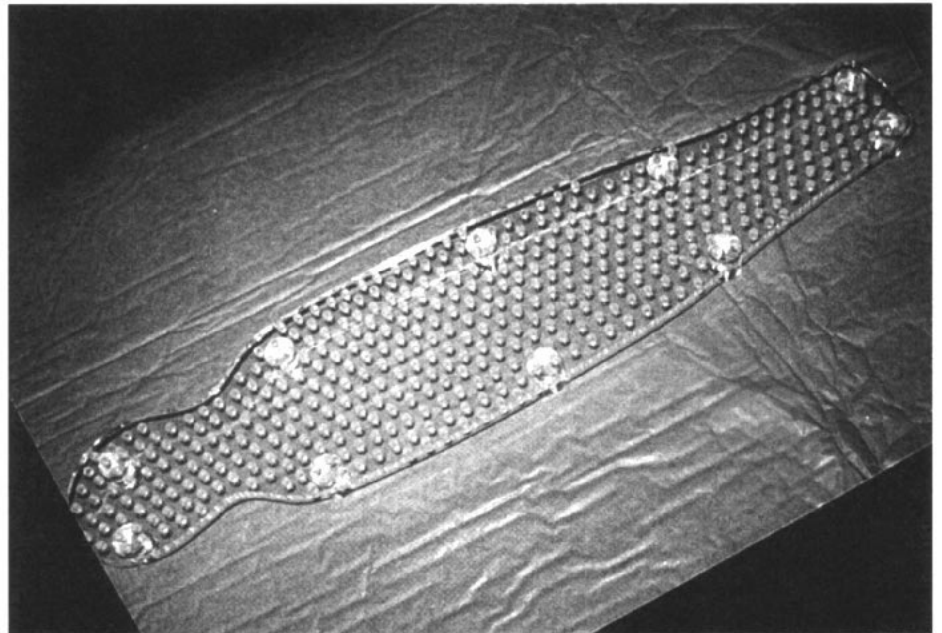

Figure 3.10

The mummy placed in a bag fabricated from a plastic that had a very low oxygen permeability.

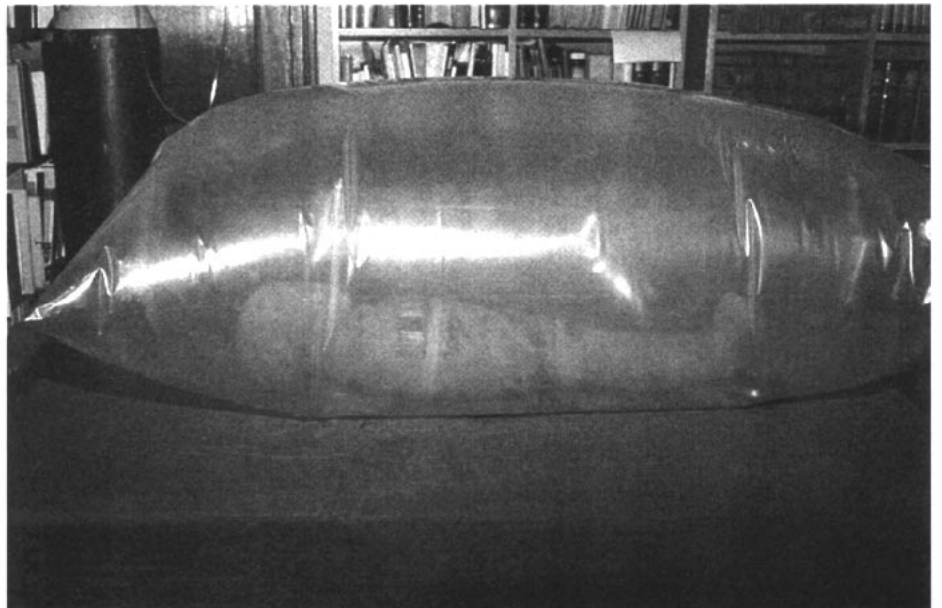
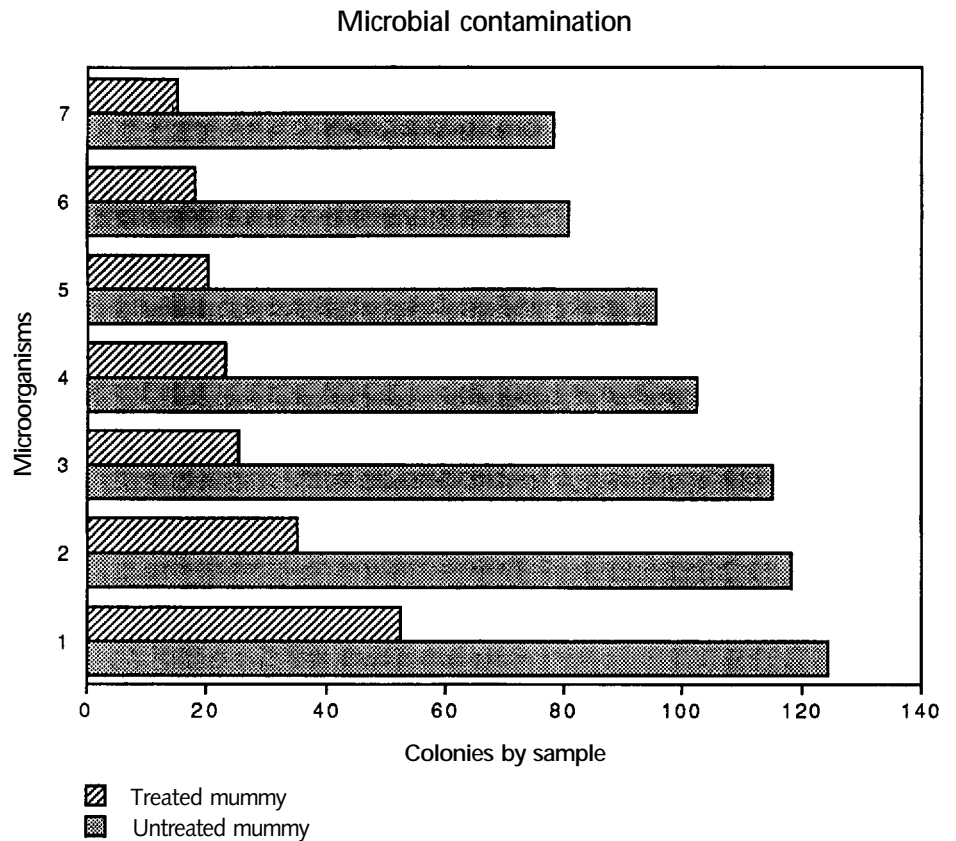

Figure 3.11

Chart showing decrease of microbial contamination in the Egyptian mummy of a child exposed to the argon atmosphere at 40% RH and 20-23 °C for five weeks.



a hermetically sealed case under an inert gas atmosphere to insure its long-term preservation (Maekawa, Preusser, and Lambert 1992; see chapter 7).

### Conclusion

Argon and nitrogen have been proven effective in killing all life forms of museum insects by depriving them of oxygen (causing anoxia); if the oxygen content of the inert gas is reduced to 0.1 %, argon works faster than nitrogen. The required duration of exposure to this inert environment depends on the insect species, life stage, oxygen content, type of inert gas, relative humidity, and temperature. (Desiccation of the insects may be the cause of their death, resulting from water loss during hyperactivity while attempting to obtain sufficient oxygen.) Carbon dioxide has been found ineffective in killing Cerambycidae, Anobiidae, and Lyctidae. Increasing the temperature in the treatment chamber from 20 °C to 30 °C markedly reduces the time required for a 100% eradication. A permanent fumigation room, a portable commercial type of "bubble," or a plastic enclosure fabricated from an oxygen-impermeable film laminate is satisfactory for insect anoxia.

Objects such as mummies and parchment, consisting of proteinaceous materials, have been found to be highly susceptible to bacterial contamination. The work discussed here shows that this contamination includes anaerobic organisms. However, the combination of low oxygen (less than 0.1 %) and low RH (less than 50%) is proved to reduce microbial activity of both aerobes and anaerobes to undetectable levels within a short exposure time.

A sealed display or storage case whose internal atmosphere (at the proper RH) consists of an inert gas with very little oxygen constitutes an efficient system for the preservation of many varieties of collections over the long term.

## Acknowledgments

The author thanks Miguel Angel Corzo and Frank Preusser for their helpful suggestions and contributions during the initial development of this project, and Montse Algueró and Carmen Martin de Hijas for their assistance in the experimental work on the disinfestation treatments. The author is also grateful to the Comisión Interministerial de Ciencia y Tecnología de España (PAT 91-0047), Spain, for providing a grant for disinfestation systems in Spanish museums and archives.

## References

**Bailey, S. W., and H. J. Banks**

1980

*Controlled Atmosphere Storage of Grains*. Amsterdam: Elsevier Scientific Publishing.

**Donahaye, E.**

1990

Laboratory selections of resistance by the red flour beetle, *Tribolium castaneum* (Herbst), to an atmosphere of low oxygen concentration. *Phytoparasitica* 18: 189-202.

**Fleurat-Lessard, F.**

1990

*Effect of Modified Atmospheres on Insects and Mites Infesting Stored Products*. Boca Raton, Fla.: CRC Press.

**Florian, M. L. E.**

1988

Ethylene oxide fumigation: A literature review of the problems and interactions with materials and substances in artifacts. In *A Guide to Museum Pest Control*, ed. L. A. Zycherman and J. R. Schrock. Washington, D.C.: Foundation of the American Institute for Conservation of Historic and Artistic Works and Association of Systems Collection.

**Gallo, F.**

1992

Il biodeterioramento di libri e documenti. In *Centro di Studi per Conservazione delta Carta*, 55-80. Rome: ICCROM.

**Gilberg, M.**

1991

The effects of low oxygen atmospheres on museum pests. *Studies in Conservation* 36:93-98.

**Hanlon, G., V. Daniel, N. Ravenel, and S. Maekawa**

1993

Dynamic system for nitrogen anoxia of a large museum objects: A pest eradication case study. In *Proceedings of the 2nd International Conference on Biodeterioration of Cultural Property, October 5-8, 1992, held at Pacifico Yokohama*, ed. K. Toishi, H. Arai, T. Kenjo, and K. Yamano, 86-90. Tokyo: International Communications Specialists.

**Hansen, E., S. Lee, and H. Sobel**

1992

The effects of relative humidity on some physical properties of modern vellum: implications for the optimum relative humidity for the display and storage of parchment. *Journal of the American Institute for Conservation* 31:325-42.

**Hutchinson, F.**

1985

Chemical changes induced in DNA by ionizing radiation. *Nucleic Acid Research Molecular Biology* 32:115-54.

**Kenjo, T.**

1980

Effects of different concentrations of oxygen on pigments used for cultural properties. *Scientific Papers on Japanese Antiques and Art Crafts* 25:103-7.

**Koestler, R.**

1992

Practical application of nitrogen and argon fumigation procedures for insect control in museum objects. In *Proceedings of the 2nd International Conference on Biodeterioration of Cultural Property, October 5-8, 1992, held at Pacifico Yokohama*, ed. K. Toishi, H. Arai, T. Kenjo, and K. Yamano, 94-96. Tokyo: International Communications Specialists.

**Koestler, R., E. Parreira, E. Santoro, and P. Noble**

1993

Visual effects of selected biocides on easel painting materials. *Studies in Conservation* 38(4):265-73.

**Kowalik, R.**

1980

Microbiodeterioration of library materials. *Restaurator* 4(2):99-114.

**Maekawa, S., F. Preusser, and F. Lambert**

1992

A hermetically sealed case for the display and storage of mummified objects in a stable inert atmosphere. In *Preprints of International Congress on Mummy Studies, 79*. Tenerife, Spain: Museo Arqueológico de Tenerife.

**Nakamura, H., and J. Hoshino**

1983

*Techniques for the Preservation of Food by Employment of an Oxygen Absorber*. Tokyo: Sanyu Publishing.

**Navarro, S., and E. Jay**

1987

Application of modified atmospheres for controlling stored grain insects. In *Stored Products Pest Control: Proceedings of a Symposium Organised by the British Crop Protection Council, the British Pest Control Association, and the Society of Food Hygiene Technology held at the University of Reading, 25-27 March 1987*, ed. T. J. Lawson, 229-36. BCPC Monograph 37. Thornton Heath, U.K.: British Crop Protection Council.

**Pääbo, S., J. Gifford, and A. Wilson**

1988

Mitochondria DNA sequences from a 7000-year-old brain. *Nucleic Acid Research* 16:9775-87.

**Petushkova, P., and G. Nikolaev**

1983

Nuclear magnetic resonance study of parchment and leather. *Restaurator* 5:242-48.

**Rust, M., and J. Kennedy**

1993

*The Feasibility of Using Modified Atmospheres to Control Insect Pests in Museums.* Marina del Rey, Calif.: Getty Conservation Institute.

**Smith, C, and J. Newton**

1991

Carbon dioxide: The fumigant of the future. Report presented at the International Seminar on Research in Preservation and Conservation, Columbia University, New York.

**Valentín, N.**

1989

Mummy deterioration halted by nitrogen atmosphere. *Nature* 338:463-64.

1990

Insect eradication in museums and archives by oxygen replacement, a pilot project. In *ICOM Committee for Conservation, 9th Triennial Meeting, Dresden, German Democratic Republic, 26-31 August 1990, Preprints*, vol. 2, ed. K. Grimstad, 821-23. Los Angeles: ICOM Committee for Conservation.

1993

Comparative analysis of insect control by nitrogen, argon and carbon dioxide in museum, archive and herbaria collections. *International Biodeterioration and Degradation* 32(4):263-78.

**Valentín, N., M. Algueró, and C. Martín de Hijas**

1992

Evaluation of disinfection techniques for the conservation of polychrome sculpture in Iberian museum. In *Proceedings of International Institute for Conservation Meeting on Conservation of the Iberian and Latin American Cultural Heritage, 9-12 September 1992, Madrid, Spain*, 165-67. London: International Institute for Conservation of Historic and Artistic Works.

**Valentín, N., and F. Preusser**

1990

Insect control by inert gases in museums, archives and libraries. *Restaurator* 11:22-33.



# Design and Construction of the GCI's Hermetically Sealed Display and Storage Case

Shin Maekawa

This chapter describes the design requirements, the physical principles, the construction details, and the installation of the inert-gas-filled, hermetically sealed display and storage case that was developed for sensitive organic and mineral materials at the Getty Conservation Institute. As detailed in Chapter 1, the production of the case was a project undertaken in collaboration with the Egyptian Antiquities Organization for the conservation of the Royal Mummy Collection at the Egyptian Museum in Cairo (Maekawa and Lambert 1993).

## Introduction

Two major approaches can be considered to maintain an inert-gas microenvironment for culturally important artifacts: continuous flushing of the case with the inert gas (a dynamic system) or the use of a tightly sealed case (a static system). The dynamic system requires a rigid case, a continuous gas supply, and active control mechanisms and electronic devices for regulating the conditions in the case. The inert gas that is flushed through the case must be humidified to match the relative humidity of the object to maintain a fixed moisture content in the object. This demands constant control of the gas's relative humidity using a fast-responding sensor. The flushing rate should be minimized, both for the system's safety and for economical operation. This is determined by the leak rate of the case, which is affected by the surrounding environmental conditions (temperature and barometric pressure). The gas supply needs to be serviced and replaced periodically. Although the concept is simple, the problem requires a complex approach. This translates to a high cost of fabrication and maintenance. Therefore, the dynamic system is not suitable for average museums, especially in developing countries, where support for highly technical tasks cannot normally be provided.

The use of these costly and sophisticated mechanical actuators and electronic controls can be avoided if a hermetically sealed (airtight) case, the static system, is fabricated. This case will require very little maintenance and monitoring if its leakage is kept to an extremely small and consistent rate. The case can be produced using existing technologies, such as fused glass, silver soldering, and O-rings. Polyisobutylene and hot-melt butyl are commonly used in the sealed insulated glass industry for sealing glass to glass or to metal. The silver-soldering technology was used in a storage case for the Charters of Freedom of the United States of America (MSB 1951) and the Constitution of Puerto Rico (Passaglia, Brown, and Dickens 1983). The O-ring and gasket technologies are used in the globe box manufacturing industry and for the construction of many hermetically sealed pieces of equipment and have been widely used in the manufacturing of vacuum equipment.

The construction and integrity of the case's hermetic seal depend on environmental conditions, particularly the temperature. If a gallery has little or no climate control, the case's seal needs to be made strong enough to withstand the pressure generated by changes of temperature. Even a minor temperature variation can translate into a major force if the surface area of the case is large. The effort of construction can be significantly reduced if the case can be built without the necessity of considering its internal pressure. This can be achieved either by providing sophisticated temperature and barometric pressure control in the gallery or by attaching a simple pressure-compensation device or bellows to the case. Obviously, the latter is a more attractive approach, considering the wide applicability of the case design to museums, which are often located in historic buildings where the installation of modern climate controls is not possible. Toishi and Koyano have reported successful use of "an air bag attached to an airtight case" in their design of exhibition cases for preserving humidity buffer materials (Toishi and Koyano 1988).



## Design Concepts for the Case

The basic concept of the inert-gas-filled, hermetically sealed display and storage system designed by the GCI is that it should provide and maintain an anoxic environment (one with greatly reduced oxygen) at a stable relative humidity for stored or displayed objects. As outlined in chapters 2 and 3, specific requirements were established for the case: it should not rely on mechanical or electrical systems, it should require minimum maintenance, it should be easily manufactured in a country with competent machinists, and it should be no more costly than an ordinary high-quality museum case.

## The Hermetically Sealed Display and Storage Case

### General description

A static system for maintaining an inert-gas atmosphere within the case was selected rather than a dynamic system, with its many complex components, for the obvious reasons of simplicity and economy. The static unit also had a long-term advantage: it required little maintenance over a multiyear period because it had no power supply and no need for periodic servicing by skilled electrical or mechanical technicians. The total GCI system consists of a display section, to which a bellows is attached, concealed below the bottom plate, and a rigid base-support assembly. The display case and its bellows are hermetically sealed from the surrounding atmosphere and filled with humidity-conditioned nitrogen, which can be monitored for oxygen content and relative humidity without opening the case (Fig. 4.1). Because of the extremely low leak rate of oxygen into the case, when it is initially filled with nitrogen and contains no more than 0.1% oxygen, less than 2% oxygen will be present as a result of leakage after ten years. If a modest number of packets of an oxygen scavenger are inserted into the case, many additional years will elapse before the 2% oxygen level is reached. A relative humidity buffering material, silica gel, that has been conditioned at a selected relative humidity should be placed in the case to provide a constant relative humidity, compensating for temperature variations and any moisture from the oxygen scavenger or the displayed objects. The case can

**Figure 4.1**  
Photograph of prototype hermetically sealed display and storage case built for an Egyptian royal mummy. Photo by T. Moon.

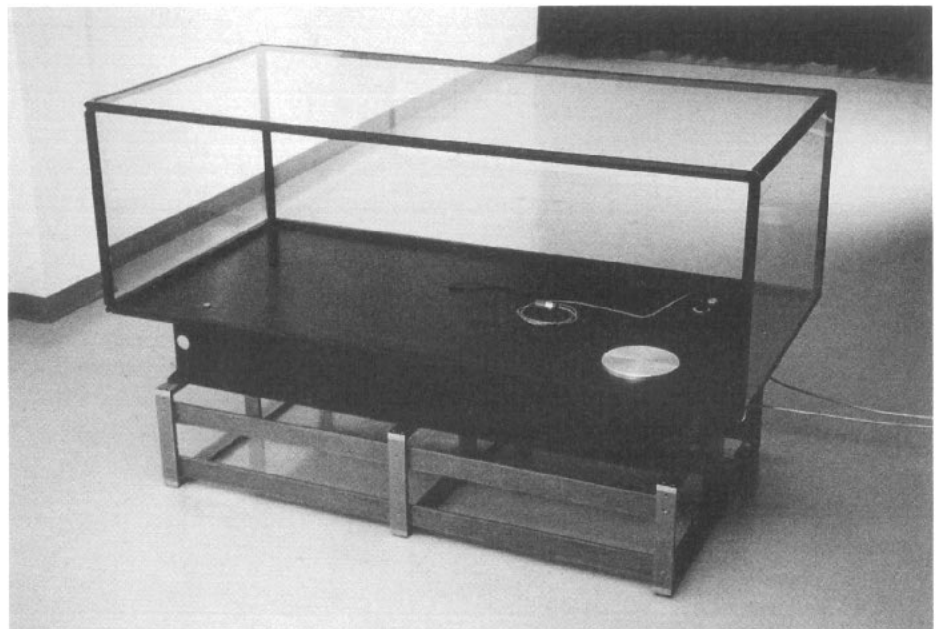

be equipped with a septum port for removing a gas sample for gas chromatographic analysis, including the analysis of potential volatiles emitted from displayed objects. Activated carbon packets can also be placed in the case to act as a sorbent for pollutants and volatiles. Pollutants could possibly be generated by the objects in the case, or (far less probably) from construction materials, or from infiltration through minute leaks over the years.

Pressure equilibration of the interior of the display case with barometric changes in the outside atmosphere is achieved by inflation and deflation of the attached bellows. Any potential temperature-induced volume changes in the inert atmosphere of the case are similarly automatically compensated for by the bellows. It is this permanent pressure-neutral condition of the case that allows such a light design and construction for the GCI hermetic seals while still assuring minimal leakage. The display section is securely mounted on the rigid base assembly, which provides a sturdy, flat, and completely level surface to avoid any strain on the seals. If the clearance between the display section and this base assembly is not adequate, the bellows can be placed inside the base assembly.

Other permanent appurtenances for the sealed case, and temporary accessories for its testing, are described in detail here.

## Construction Details of the Hermetically Sealed Case

### Display section

The display section (91.5 cm wide, 182.9 cm long, and 61 cm high in the prototype case) consists of four side panels and a top section of laminated glass, 1/4 in. (6.35 mm) thick, mounted in an aluminum frame that is structurally supported by a 2024 aluminum bottom plate of the same thickness. The bottom plate is strengthened by two pairs of aluminum U-channel supports, each 8 in. (20.32 cm) long, attached to it using an aluminum epoxy, one near each end and one near each side. The frame is constructed by bolting the custom-designed extruded aluminum rods (Fig. 4.2) to the machined corner elements (Figs. 4.3-5), which are also made of 2024 aluminum alloy, with a thin film of neutrally curing silicone sealant. This design simplified the fabrication and reduced the cost as compared with that of helium-arc-welded corners. (Extrusions of the prototype case donated to the EAO were welded at the corners.) Seals between the glass, or the aluminum bottom plate, and the frame (Fig. 4.6) are effected by the Viton O-rings under pressure exerted by retaining strips, precisely bent and heat-treated aluminum plates (Fig. 4.7). All the aluminum components are black-anodized to prevent corrosion from moisture and pollutants in the atmosphere and, for aesthetic reasons in a display case, to reduce reflections from the surfaces.

Six ports of 1/4 in. (6.35 mm) diameter are drilled, and one large access port, 8 in. (20.32 cm) in diameter, is machined in the aluminum bottom plate (Fig. 4.8). The small ports are all fitted with tube connectors and designed for nitrogen purging, recalculating to an external oxygen analyzer, attachment to a microfilter and manometer, and connection to the bellows. The large port has an O-ring-sealed cover with bolts welded within the circle of the O-ring (the cover closes from the inside of the case) and is used for insertion and replacement of the oxygen scavenger, the pollution sorbent, the silica gel humidity buffer, and the sensors. Other ports could be easily added, for example one with a septum to allow samples of the case atmosphere to be taken with a syringe. (The air samples can be analyzed for volatiles if it is suspected that these may be emitted by the displayed objects. Of course, should this analytical work be of interest, activated-carbon sorbent should not be put in the case.)

Figure 4.2  
Mechanical drawing of the extrusion profile.

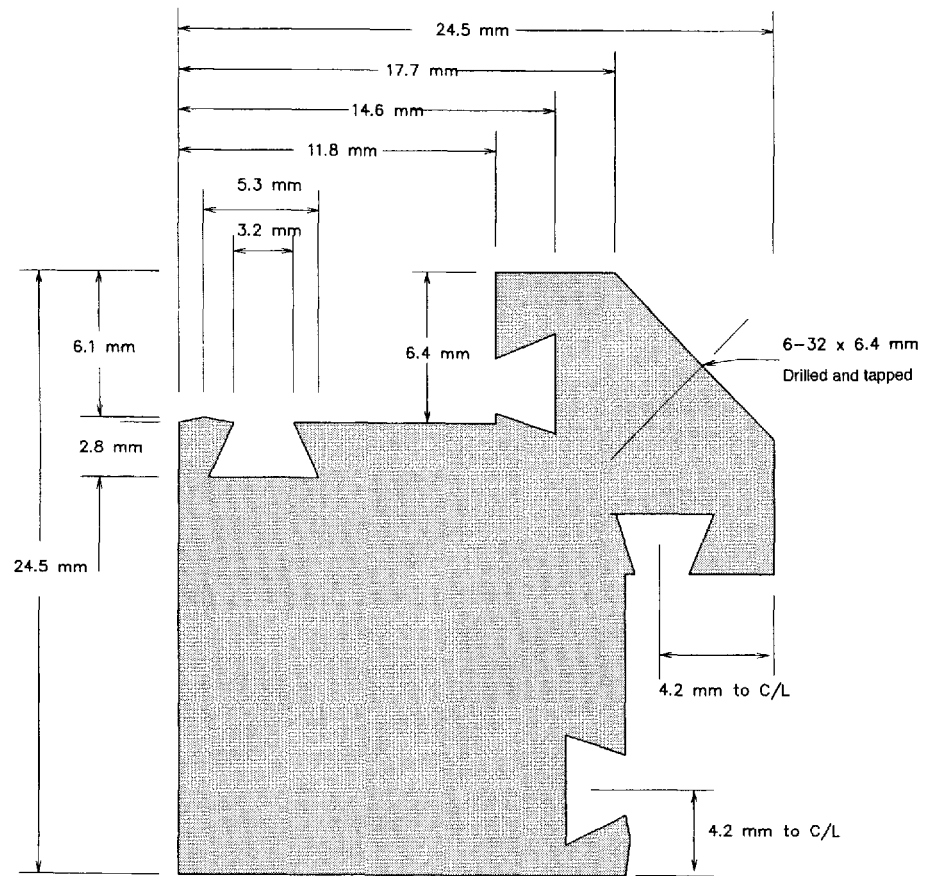

An oxygen sensor and a temperature and relative humidity (RH) sensor/transmitter are placed inside the case and their electrical leads are soldered to a hermetically sealed electrical connector mounted on the aluminum bottom plate. Excitation voltage is supplied to the temperature and RH sensor by its monitor outside the case; similarly, the voltage developed by the oxygen sensor is recorded as the oxygen percentage on its external monitor. The electronic temperature and RH sensor can be replaced by a bimetallic temperature indicator and a synthetic hair-type RH indicator. This both reduces the cost of the accessories and simplifies their installation and operation.

The case can be equipped with a removable U-tube manometer for monitoring pressure in the case while it is purged with nitrogen. (Even small overpressures can threaten the seals in a large case.) A pressure-relief valve can be mounted on the aluminum bottom plate to provide additional safety against overpressure inside the case during purging.

### Bellows

A pillow-shaped bellows made of plastic and metal (Fig. 4.9) is connected using an O-ring-sealed male tube connector on one of the corners of the "pillow" to copper tubing that leads to fittings in the aluminum bottom plate. The bellows is made by heat-sealing two rectangles of oxygen barrier film, such as Marvelseal 360 (a laminated film of nylon on aluminized polyethylene) or Filmpak 1193 (ethylene vinyl alcohol-laminated film), at all four edges after holes are carefully cut in the bellows and the tube connector is inserted and tightened. The bellows functions by expanding and contracting during external temperature or barometric fluctuations, thereby preventing any pressure on the seals of the display section. The bellows, whose volume is recommended to be at least one-tenth of the display section's volume for a 25 °C temperature variation in the external

Figure 4.3  
Mechanical drawing of a corner  
element.

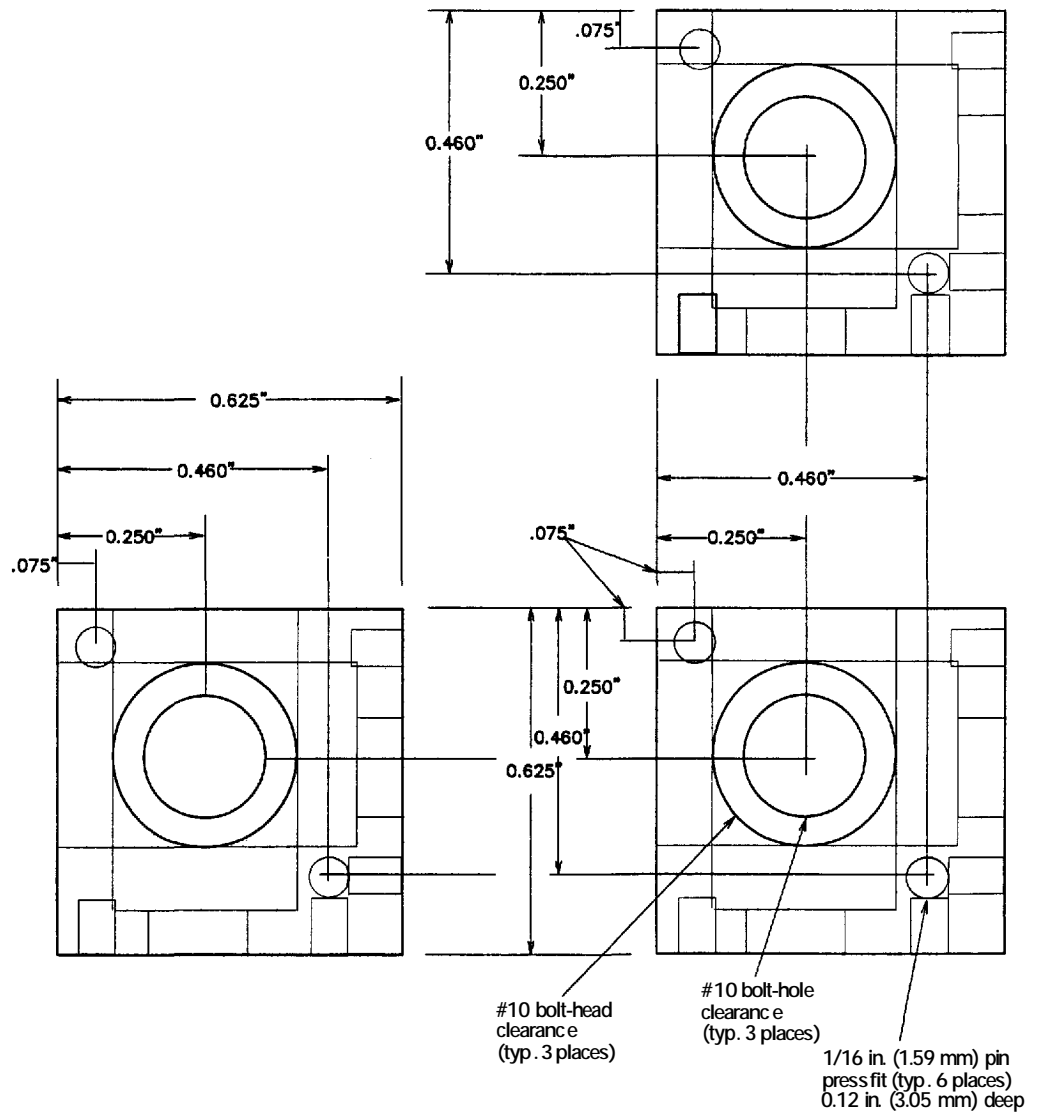

environment, rests directly below the aluminum bottom plate with enough vertical clearance for its expansion. (It must be supported from below to avoid placing any strain on the O-ring seals in its tubing fittings.) A larger bellows is recommended if greater temperature variations are expected where the case is to be located. To avoid leaks arising from stresses on the film or on its seam and O-ring seals, the bellows should be not be twisted or constrained in any way.

#### Passive control agents

**Oxygen Scavenger** The commonly used oxygen scavenger Ageless (Fig. 4.10), developed for the packaged-food industries, has been successful in preventing the oxidation of food as well as the growth of microorganisms. It consists of a finely divided iron oxide powder, potassium or sodium chloride, and a zeolite containing water, packaged in an oxygen-permeable plastic packet. Reaction with oxygen of the type of Ageless called Ageless-Z is most rapid at 75% RH, but it is significant even at 45% RH. Ageless-Z contains approximately 3.4 g of water in the Z-1000 packets, which are said to absorb 1000 cc of oxygen. (The packets bear designations from Z-100 to Z-2000 to indicate their oxygen-absorbing capacities. The manufacturer has been putting enough chemical in each packet to react with three times its nominal oxygen capacity, to allow for exposure to ambient air during the placement of the packets in packages.) The

Figure 4.4  
Mechanical drawing of a drilled extrusion end  
for the corner assembly.

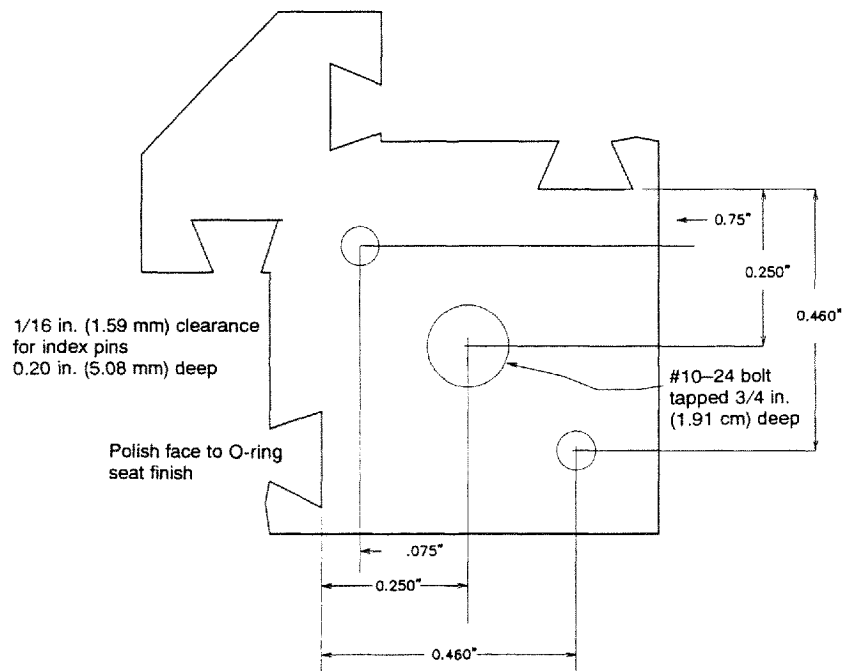
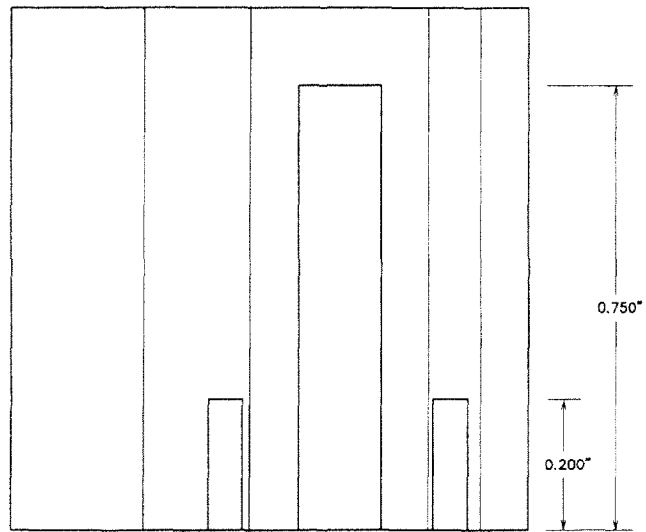

Figure 4.5  
Photograph of the corner assembly.

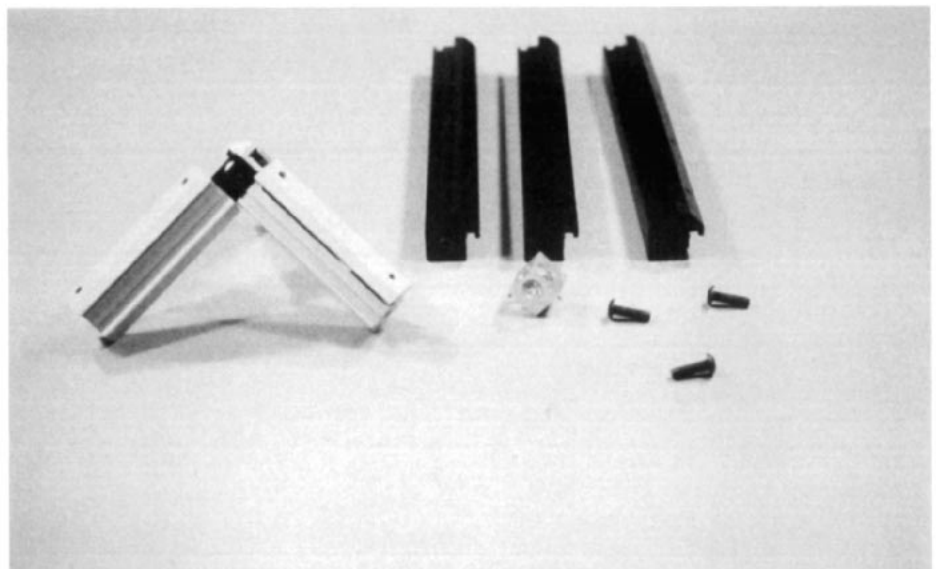
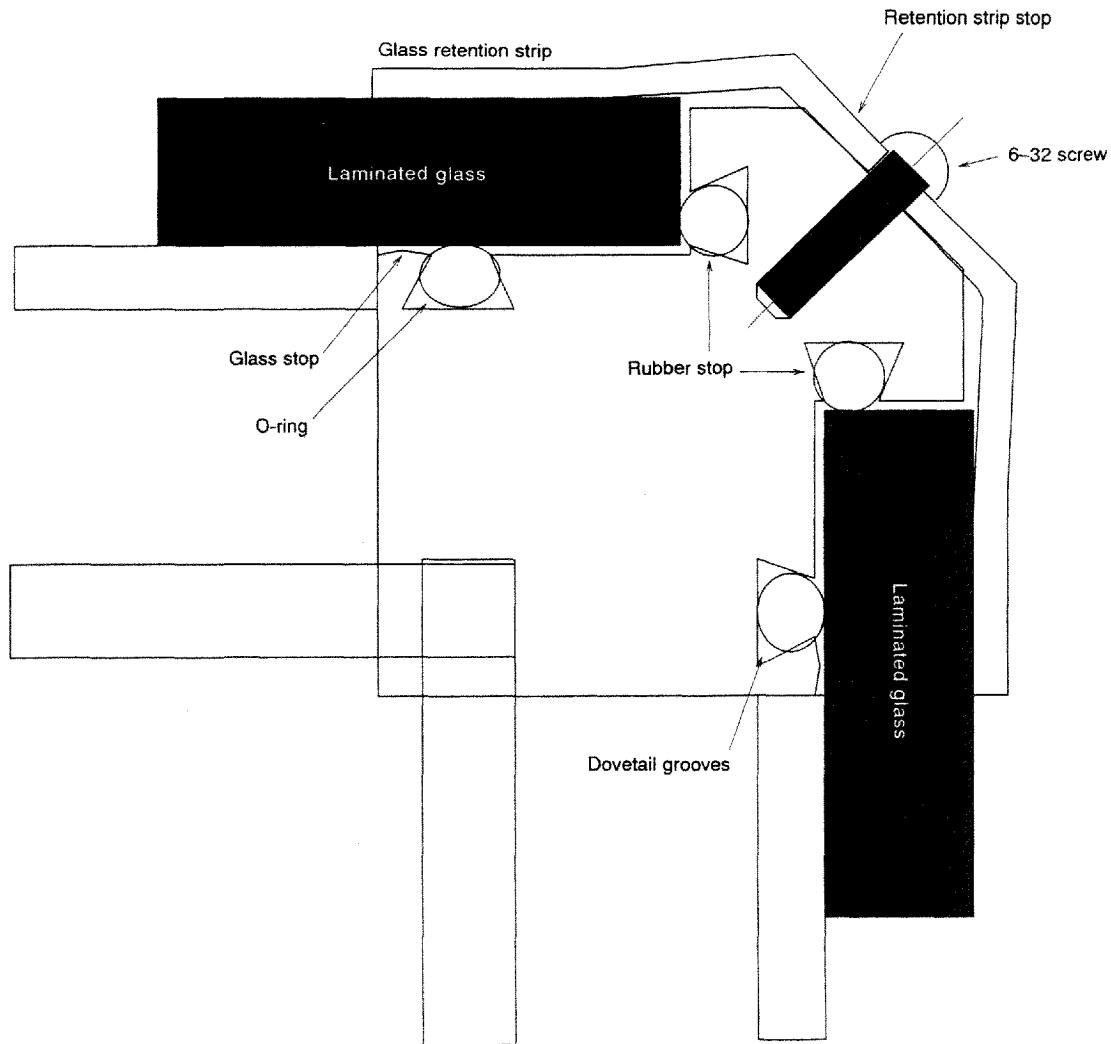

Figure 4.6  
Schematic of the hermetic seal.



number of packets that must be placed in the case can be determined from the oxygen leak rate of the case and the desired length of time before the packets need to be replaced. The kinetics of the reaction of Ageless with oxygen in sealed cases are reported by various investigators (Abe and Kondoh 1989; Mitsubishi Gas Chemical Co. 1994; Lambert, Daniel, and Preusser 1993).

**Relative Humidity Buffer** The case does not need protection from infiltration of moisture from, or loss to, its surroundings because its leak rate is so low. However, moisture can enter or leave the case whenever it is opened, for instance, during replacement of the passive control agents or servicing of the sensors. An oxygen scavenger, such as Ageless, itself contains a small amount of water and the moisture is released over time. The object displayed in the case may not be at its optimal long-term RH level and even multiday purging with nitrogen at this RH does not bring it to that level. Temperature changes in the case result in RH fluctuations. To moderate these rapid fluctuations somewhat and to insure the long-term maintenance of the proper RH, an appropriate amount of humidity buffer should be inserted just before the case is sealed.

Selection of a humidity buffer, such as silica gel, Artsorb, or molecular sieves, must be based on the effectiveness of the material in the RH range at which the objects will be stored, the cost, and the local availability of the products. The amount to be used depends on the volume of the case and the hygroscopic

Figure 4.7  
Mechanical drawing of the retention strip.

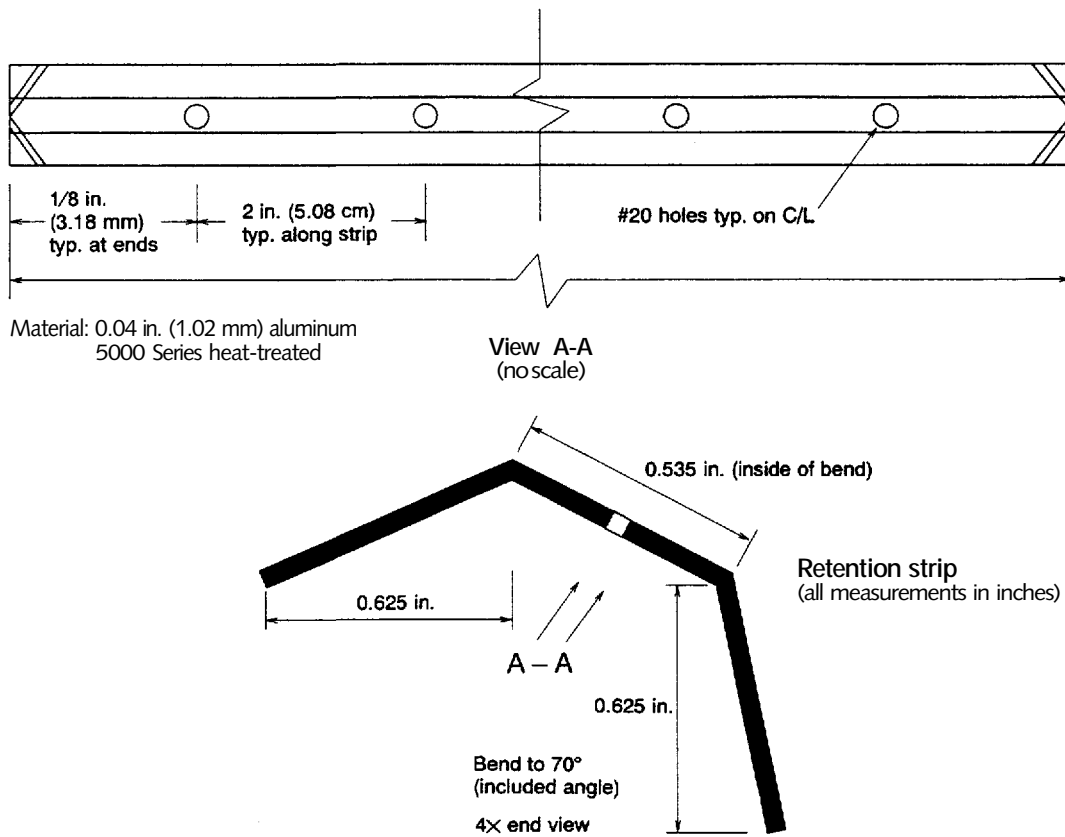

Figure 4.8  
Mechanical drawing of the bottom plate.

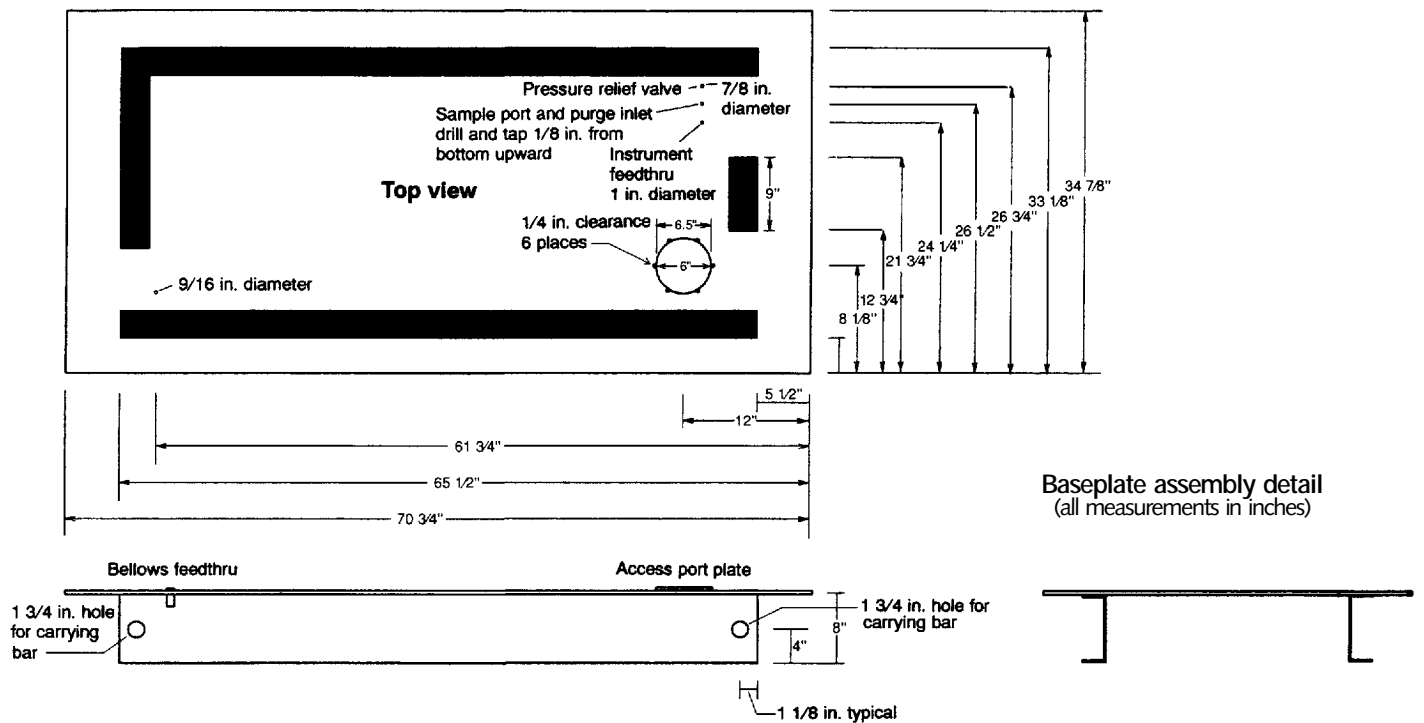
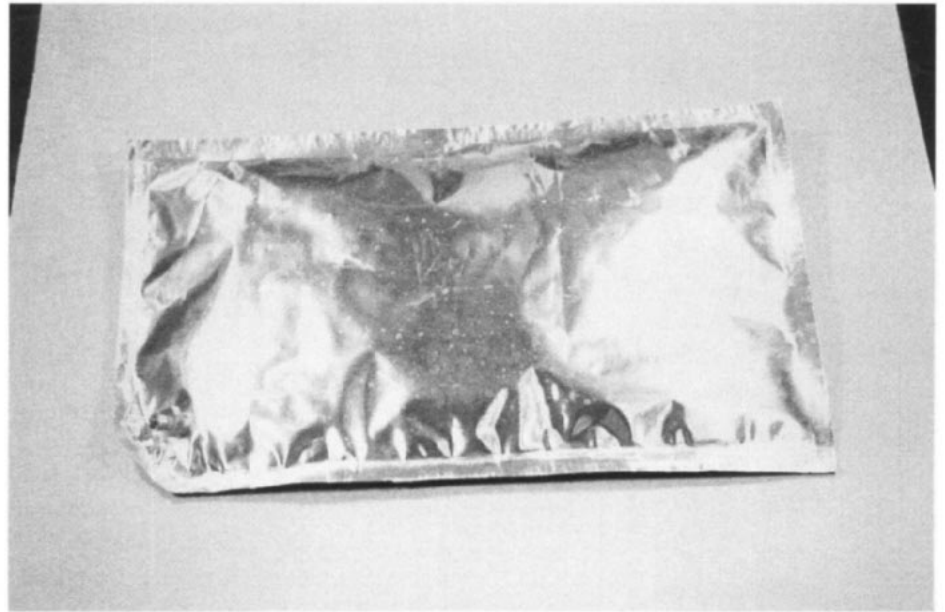

Figure 4.9

Photograph of the aluminum-plastic bellows.



capacity of the object as described by investigators (Thomson 1986; Weintraub 1980). Spreading the buffer in trays that afford the largest convenient surface area will facilitate a rapid response to change, resulting in a stable RH level.

**Pollution Sorbent** The case is designed for use with packets of pollution sorbent to protect the contents from internal pollutants and from ingress of any undesirable substances from the external environment. Internal pollutants include volatile gases slowly emitted from the displayed objects and minute outgassing of some component of the case, such as the O-rings. Even though the composition and quantity of these internal pollutants have not been thoroughly investigated, those of outdoor and museum pollutants and their levels have been well studied. Therefore, the selection of the pollution sorbent has been based on the studies by Parmar and Grosjean of undesirable substances in a typical museum (Parmar and Grosjean 1990). Activated carbon is capable of absorbing these museum pollutants of  $\text{No}_x$ ,  $\text{SO}_2$ ,  $\text{CO}$ ,  $\text{CO}_2$ ,  $\text{O}_3$ , and hydrocarbons at a level of approximately 50 ppb. The quantity to be used is calculated from the case size and the time before service will be required.

Figure 4.10

Photograph of an oxygen scavenger, Ageless.

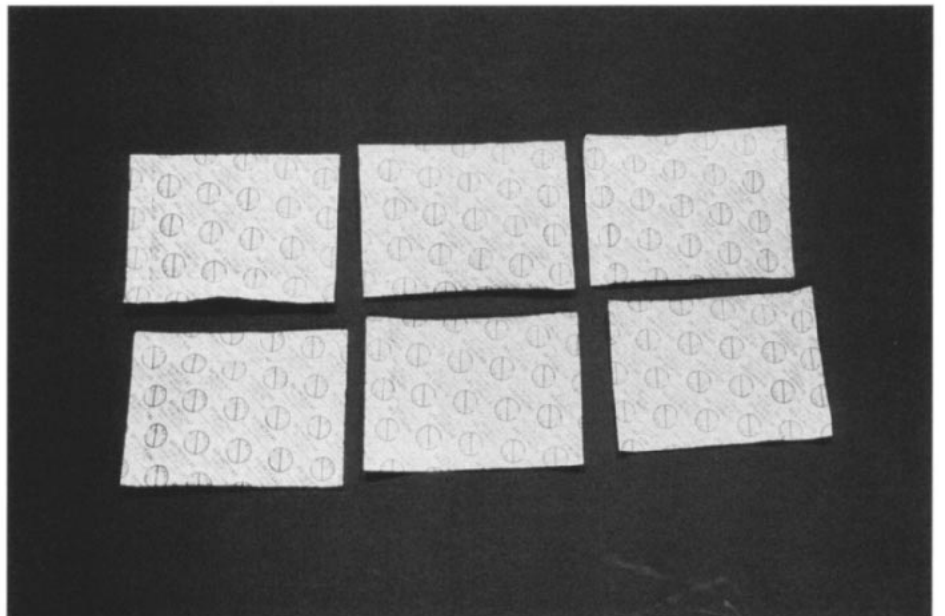



## Evaluation of Performance and Installation

### Leak testing and performance evaluation

Descriptions of the procedures that were used for the GCI sealed case and the results that were observed are given in the following section. First, the case and bellows were tested for major leaks using Freon or helium gas in the case and checking to find any transmission through seals by using a halogen detector. Then the case and bellows were thoroughly purged with dry nitrogen. The resulting nitrogen-filled system was allowed to equilibrate, and the initial oxygen concentration was measured by circulating a gas stream from the case through a metal diaphragm pump and trace oxygen analyzer and back to the case and bellows.

During the testing period, the temperatures of the room and of the sealed case were periodically raised as much as 10 °C above normal room temperature to simulate variations of temperature and barometric pressure that might occur under actual extremes of gallery conditions. Oxygen concentrations in the case were measured daily for seven to ten days to determine the average oxygen (and thereby air) leak rate of the case.

The leak rate of atmospheric oxygen into the case ranged up to approximately 20 ppm per day for the arc-welded prototype, which had a volume of 1000 l. It improved to less than 5 ppm per day for five new cases (four of 500 l and one of 96 l) produced with a later improvement in design: the use of bolted corner elements. At an achievable leak rate of 5 ppm per day, if the oxygen concentration in the sealed case is brought down to less than 0.1 % (1000 ppm), it will take more than ten years for the oxygen concentration inside the case to reach 2%. (This is without the presence of an oxygen scavenger, of course, and it assumes a constant leak rate over the ten-year period.)

In ten years, a calculated 18000 cc of oxygen will leak into the case, the amount that can be absorbed by nine packets of Ageless Z-2000 or eighteen of Ageless Z-1000. Therefore, the maintenance-free period of the case could be extended to twenty years by the insertion of Ageless. It can be further extended to forty years by inserting eighteen packets of Z-2000 or thirty-six packets of Z-1000.

**Purging of the Case in the Presence of Objects** It is essential to control the relative humidity in a display case when an object has been placed inside it. Therefore, nitrogen gas that is passed into the case containing an object must be carefully humidified. Figure 4.11 is a simplified schematic of the original nitrogen gas supply system. RH-conditioned nitrogen is produced by controlling the mixing ratio of dry nitrogen from the tank to moist nitrogen (produced by bubbling tank nitrogen through water at room temperature). Maekawa and Elert have recently published the details of a gas humidification system whose controllability has been significantly improved (1996).

As the RH inside the case is being adjusted by humidified nitrogen and the oxygen is being purged, a trace oxygen analyzer is used to follow the decrease in oxygen each day. The purging process is near its end when the oxygen content reaches 1000 ppm.

The exhaust port of the case can be fitted with a microfilter to prevent bacteria and fungal spores on the object from being dispersed to the museum atmosphere during flushing. Pleated Teflon (PTFE) membrane filters with a retention rating of 0.5 µm and a large filtration area should be selected to prevent disastrous pressurizing of the case and bellows.

Figure 4.11  
Schematic of the purging setup.

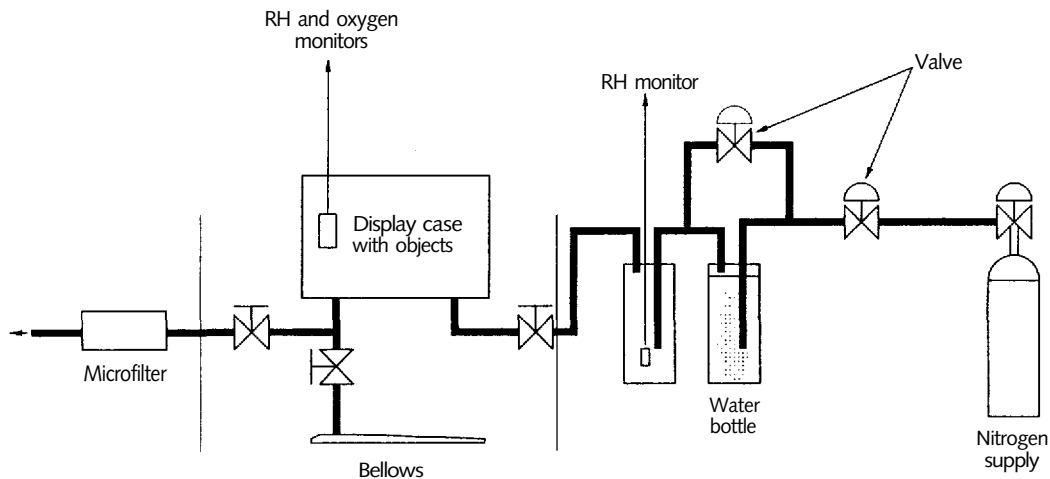

When the oxygen level in the case is below 1000 ppm, the appropriate amounts of passive control agents, humidity buffer, oxygen scavenger, and pollution sorbent are placed in the case through the access port. (To minimize the introduction of air during this step, the nitrogen flow can be increased greatly when the large port is open. However, extreme vigilance must be exercised to instantly decrease the nitrogen flow to the previous slow rate as soon as the port is nearly closed, after the placement of the agents.)

Once these procedures have been completed and the access door is tightly bolted, the valves from the nitrogen supply system and to the microfilter are closed and both the microfilter and the tubing to the nitrogen are removed from the case. Similarly, valves to the trace oxygen analyzer are closed and its tubing to the case disconnected.

Reflushing of the case with nitrogen is necessary when the oxygen concentration in it, as measured by its internal passive monitor, reaches 2%. The control agents can also be renewed at this time.

### Summary

A hermetically sealed display and storage case that can be filled with an inert gas was successfully designed, fabricated, and tested at the Getty Conservation Institute. Maintenance of the case requires no electrical or mechanical system. Because it is relatively easy to build without special tools and requires only a skilled machinist for its fabrication, it can be made both in developed and developing countries. Humidity-conditioned nitrogen was used as the inert atmosphere in the first GCI display case; other inert gases, such as argon and helium, can be substituted. Because the case can be built so that only 5 ppm per day or less of atmospheric oxygen will leak into it, the maintenance-free life of the case is approximately ten years if the case is purged to an initial oxygen level of 1000 ppm. This period can be extended to more than twenty years if a modest quantity of oxygen scavenger is introduced after the initial purge.

The display cases have now been produced by the Supreme Council of Antiquities for the display and storage of the Royal Mummy Collection at the Egyptian Museum in Cairo; for an Egyptian child mummy at the Biblioteca-Museu Victor Balaguer in Vilanova i la Geltrú, Spain; and for the Constitution of India at the Parliament Library in New Delhi, India. Most recently, Dorset Conservation, Inc., of Toronto successfully built a GCI-designed hermetically sealed display and

storage case for the Royal Proclamation Charter for the Company of Adventure, Hudson's Bay Company, Toronto.

Because construction of the case is labor-intensive (approximately 100 hours of a master machinist's work), its cost varies depending on the country where it is produced. In the United States, the cost of building a 1000-liter case in 1992 was approximately US\$10,000, but this cost could be significantly reduced if several cases are fabricated at the same time.

## Acknowledgments

The project was initially directed by Frank Preusser and later by Neville Agnew. Frank Lambert developed leak-testing procedures. Detailed mechanical design and fabrication of the prototype case were contracted to Lightsense Corporation, Laguna Beach, California. Mitsubishi Gas Chemical Company donated the Ageless oxygen absorber throughout the project. The author thanks these firms for their cooperation and technical support throughout the project.

## Materials and Suppliers

### Extrusion

Profile parts number: TMS 60-30780; alloy: AL 6061; temperature treatment: T6511

*Source:* Tiernay Metals, 2600 Marine Ave., Redondo Beach, CA 90278-1197

### O-ring cord stock

Material: Viton; nominal diameter 1/8 in. (3.18 mm)

*Source:* McMaster-Carr Supply Co., 9630 Norwalk Blvd., Santa Fe Springs, CA 90670 (or local O-ring supplier)

### Grease

Silicon O-ring lubricants

High-vacuum grease

*Source:* McMaster-Carr Supply Co. (or local hardware suppliers)

### Glass Panels

1/4 in.- (6.35 mm) thick laminated glass

### Bottom Plate

Aluminum epoxy (Devcon aluminum-filled epoxy)

*Source:* McMaster-Carr Supply Co. (or local hardware supplier)

Tube connector: 1/4 in. (6.35 mm) Swagelok O-seal straight thread male connector

Valve: Whitey model 42S4 1/4 in. (6.35 mm) 2-way valve

Hermetically sealed electrical connector (electrical feedthrough)

*Sources:*

Douglas Engineering Company, 14 Beach St., Rockaway, NJ 07866

Omega Engineering, 1 Omega Dr., Stamford, CT 06907

Aluminum sheet: 1/4 in. (6.35 mm) sheet (alloy: 2024 Series aluminum)

U-channels: 8 in.- (20.32 cm) base U-channels (alloy: 5000 Series aluminum)

### Access Plate

O-ring: APR 568-365 (material: Viton)

*Source:* O-Rings, Inc., 2260 Centinela Ave., Los Angeles, CA 90064 (or local O-ring suppliers)

Aluminum plate: 1/2 in. (1.27 cm) aluminium plate (alloy: 5000 Series)

Threaded Studs: no. 10-32 (4.8 mm diameter, 95 mm deep) Wing Nuts: no. 10-32 (4.8 mm diameter, 12.7 mm deep)  
Washers: no. 10 (4.8 mm inner diameter)

#### **Corner Element**

1 in.- (2.54 cm) square stock rod (alloy: 2024 Series aluminum)  
Button-head cap screw: no. 10-32  
Stainless steel pins: 1.6 mm diameter, 8 mm long  
Noncorrosive RTV silicone filler: Dow 748 Noncorrosive RTV Silicone or GE Noncorrosive Fast-Cure RTV Silicone

#### **Retention Strip**

1/16 in.- (1.59 mm) thick aluminium sheet (alloy: 6061 Series aluminium, heat-treated)  
Button-head cap screws: no. 6-32, 0.953 mm

#### **Oxygen Sensor**

Model 320 Portable Oxygen Analyzer or Model 311 Portable Trace Oxygen Analyzer  
*Source:* Teledyn Analytical Instruments, 16830 Chestnut St., City of Industry, CA91749

#### **Bellows**

Marvalseal 360  
Filmpak1193  
*Source:* Ludlow Laminating and Coating Division, Homer, LA 71040  
Heat-sealing iron  
Tube connector: 1/4 in. (6.35 mm) Swagelok O-seal straight thread male tube connector  
Nuts: no. 7/16-20  
Washers: Dash no. 815, 3/8 in. (9.53 mm), 0.438 in. (1.1125 cm) inner diameter, 1 in. (2.54 cm) outer diameter  
*Source:* McMaster-Carr Supply Co. (or local hardware shops)

#### **Temperature/Relative Humidity Sensor and Thermo-Hygrometer**

*Source:* Cole-Parmer Instrument Co., 7425 North Oak Ave., Niles, IL 60714

#### **Leak Detector**

Halogen Leak Detector  
*Source:* Gas Tech Inc., Newark, CA

#### **Custom Humidification System**

High-density polypropylene bottles  
Flow meter  
Nylon tubing  
*Sources:*  
Fisher Scientific, 711 Forbes Ave., Pittsburgh, PA 15219  
Cole-Parmer Instrument Co., 7425 North Oak Ave., Niles, IL 60714

#### **Tube Fittings and Connectors**

*Source:* Swagelok Co., 31400 Aurora Road, Solon, OH 44139

#### **Valves**

*Source:* Whitey Co., 318 Bishop Road, Highland Heights, OH 44143

#### **Nitrogen**

*Source:* Union Carbide Industrial Gases Inc., Linde Division, Somerset, NJ 08875 (or local gas suppliers)

## References

**Abe, Y., and Y. Kondoh**

1989

Oxygen absorbers. In *Controlled/Modified Atmosphere Vacuum Packaging of Food*, ed. Aaron L. Brody, 149-58. Trumbull, Conn.: Food and Nutrition Press.

**Lambert, F., V. Daniel, and F. Preusser**

1993

The rate of absorption of oxygen by Ageless: The utility of an oxygen scavenger in sealed cases. *Studies in Conservation* 37:267-73.

**Maekawa, S., and K. Elert**

1996

Large-scale disinfestation of museum objects using nitrogen anoxia. In *ICOM Committee for Conservation 11th Triennial Meeting, Edinburgh, Scotland, 1-6 September 1996, Preprints*, ed. J. Bridgland, vol. 1, 48-53. London: James and James.

**Maekawa, S., and F. Lambert**

1993

The Getty Conservation Institute's Inert Atmosphere Display and Storage Case for the Pharaonic Mummies of the Egyptian Museum, Cairo, Final Report. GCI Scientific Program Report, December.

**Mitsubishi Gas Chemical Co.**

1994

*Ageless Oxygen Absorber: A New Age in Food Preservation*. Tokyo: Mitsubishi Gas Chemical Co.

**National Bureau of Standards (NBS)**

1951

Preservation of the Declaration of Independence and the Constitution of the United States. NBS Circular 505. Report by the National Bureau of Standards to the Library of Congress, July 2, Washington, D.C.

**Parmar, S. S., and D. Grosjean**

1990

Sorbent removal of air pollutants from museum display cases. *Environment International* 16(6):39-50.

**Passaglia, E., D. Brown, and B. Dickens**

1983

The preservation of the Constitution of Puerto Rico. Final Report NBSIR83-2473, National Bureau of Standards, Washington, D.C.

**Thomson, G.**

1986

*Museum Environment*. 2d ed. London and Boston: Butterworths.

**Toishi, K., and M. Koyano**

1988

Conservation and exhibition of cultural property in the natural environment in the Far East. In *The Conservation of Far Eastern Art: Preprints of the Contributions to the Kyoto Congress, 19-23 September 1988*, ed. John S. Mills, Perry Smith, and Kazuo Yamasaki, 90-94. London: International Institute for Conservation of Historic and Artistic Works.

Weintraub, S.

1980

A New Design for a Low Maintenance Silica-gel System for the Control of Relative Humidity in a Sealed Case. In *Conservation within Historic Buildings: Preprints of the Contributions to the Vienna Congress, 7-13 September 1980*, ed. N. S. Brommelle, Carry Thomson, and Perry Smith, 55-56. London: International Institute for Conservation of Historic and Artistic Works.



## Chapter 5

# Controlled- Environment Cases for the Royal Mummy Collection

Nasry Yousef Iskander

This article describes the work of constructing hermetically sealed cases to preserve and display the collection of royal mummies at the Egyptian Museum in Cairo. Based on the prototype of a hermetically sealed display and storage case developed and presented to the Egyptian Museum by the Getty Conservation Institute, the cases were made, insofar as possible, from materials that were locally available in Egypt.

Even with the continual support of the GCI, the project proved to be difficult. A number of cases were completed, however, that are quite similar to the original GCI prototype, and they are functioning well. They should succeed in protecting these historically important mummies. The 1994 cost per case in Egypt was approximately US\$2,000, suggesting that display cases of this sort can be made for treasured objects in other countries for quite reasonable amounts.

Excavated mummies are threatened by microbiological growths, insect attacks, air pollution, and large fluctuations in temperature and humidity. The Egyptian Museum in Cairo has a collection of twenty-seven royal mummies (Fig. 5.1) whose preservation is of both national and historical concern. As discussed in chapter 1, the Egyptian Antiquities Organization (EAO; now the Supreme Council of Antiquities) collaborated with the Getty Conservation Institute to design and produce the prototype of a display (or storage) case that would protect mummies from all of the aforementioned threats, except temperature fluctuations.

The complex research and development required for this unique case was completed by GCI staff and contractors working under their direction in late 1988; construction of the prototype model and testing were finished by early 1989. In May of that year, the prototype was presented to the EAO, whose task it then was to fabricate some twenty-seven cases based on the GCI's design using Egyptian materials and workers.

### Case Construction in Egypt

The major task of the EAO during the first year was trying to duplicate some of the ingenious features of the GCI prototype. Essential components of the hermetic seal of the case are the twelve slender extrusions that make up its frame and contain grooves for the O-ring seals that fit into them. The most

Figure 5.1

Photograph of the old Royal Mummy Room in the Egyptian Museum, Cairo, Egypt. Photo by Guillermo Aldana.





complex of the components are the eight welded corners that hold the twelve extrusions.

These corners posed a special problem because in the original GCI design they are precisely arc-welded. Using the EAO's facilities and available techniques or those that could be located in Egypt, fabricators found that the heat of welding was causing serious distortions at the corners. They found it impossible to produce the welded corners that could ensure accurate extrusion attachment and O-ring placement to guarantee a perfect hermetic seal at these critical points.

Initially, procurement of the aluminum extrusions for the frames of the cases also proved difficult, even though there are competent aluminum fabricators in Egypt. Thanks to the GCI, a design improvement for the corners that uses screws instead of welding was sent to the EAO in late 1989. The drawing for the new design was further clarified by Shin Maekawa of the GCI, who made several trips to Egypt to provide invaluable aid, both in interpreting the plan and in helping to solve a number of other problems in this first phase of the project.

Because of the limitations of local suppliers, it was necessary to modify several components of the GCI design. Figures 5.2 and 5.3 show schematic drawings of the EAO version of the GCI-designed case. For example, a decision was made to use 7 mm tempered glass for the sides and top rather than the 1/4 inch (6.35 mm) laminated glass of the original, and to use 3 mm nonanodized aluminum sheet with a 3.5 mm plywood backing for the baseplate rather than a black-anodized 1/4 inch (6.35 mm) aluminum baseplate. Machining brass is much easier than machining aluminum; thus, the corner elements were made from brass. Heat-treating the aluminum retention strips to make them springlike in holding the glass sides and top to the frames was not easy, so strips that were

Figure 5.2  
Exploded view of the Egyptian Antiquities Organization's version of the hermetically sealed display and storage case designed by the Getty Conservation Institute.

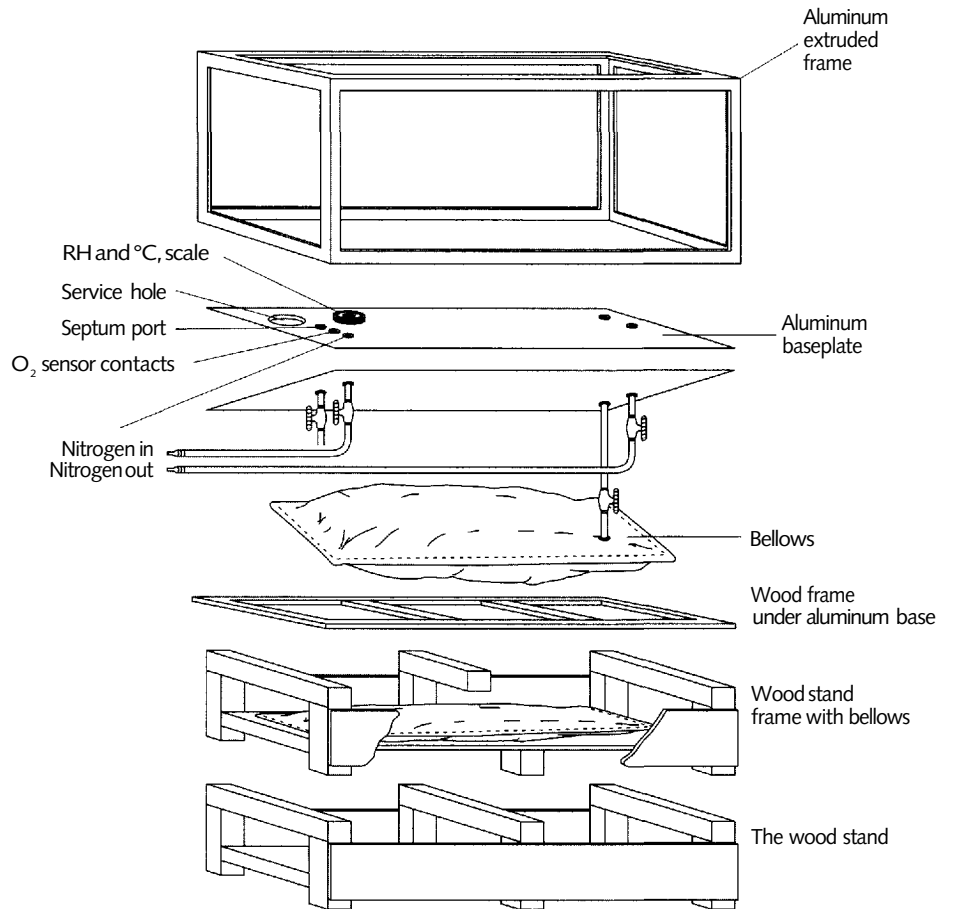

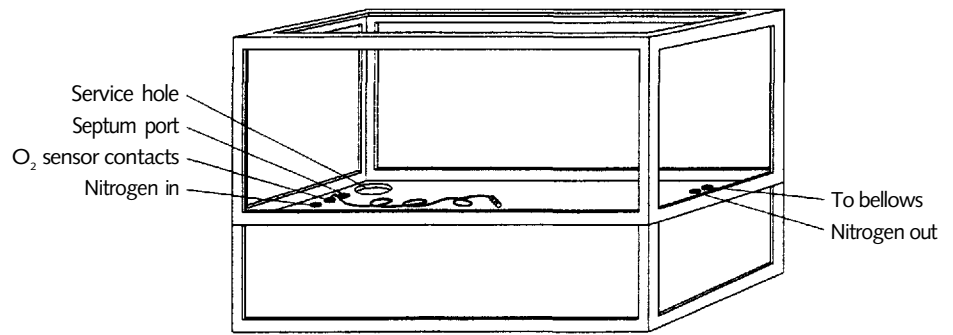

**Figure 5.3**  
Schematic drawings of the EAO's hermetically sealed display and storage case.

somewhat thicker (without heat-treating) were used to achieve a similar goal. Because of their thickness, the number of screws holding the sides and top could be reduced by placing screw holes at 10 cm rather than 5 cm intervals. Two final modifications were the doubling of the size of the bellows from about 100 l to about 200 l, and the use of a round steel access cover in the baseplate instead of a 12.7 mm aluminum cover.

For a shape that would be more suitable for display of the mummies in the Egyptian Museum, we changed the size of the case (to 80 cm wide by 60 cm high by 200 cm long, rather than 91 cm by 60 cm by 183 cm). Further, the overall height of the support beneath it was reduced, and the light colored wood frame that was made hides the metal edges for greater visual appeal.

Finally, in 1991, the first case was assembled, with its valves in the baseplate (for input of nitrogen, output to the oxygen analyzer, and connection to the bellows) and its glass sides, glass top, and baseplate firmly fitted by the retention strips to the O-rings, which were thinly coated with silicone grease. The EAO team then began the leak-testing process. With the access cover in the baseplate partly open, the air was thoroughly flushed from the case using a rapid flow of nitrogen through the input valve. Quickly closing the door after stopping the nitrogen flow, the team started the pump to circulate the case's atmosphere through the oxygen analyzer and back to the case.

Unfortunately, the initial leak rate was 500 ppm of oxygen per day, approximately 25 times what the GCI had measured in the prototype. By applying neutrally curing silicone elastomer to the corners (the most probable source of leaks), the oxygen leak rate was reduced to 200 ppm per day. However, this was still ten times what is desirable for long-term sealing of the case atmosphere from the outside museum air. It took seven months of work—repeatedly disassembling and reassembling the entire structure, carefully sealing the corners and any missed spots on the O-rings with silicone grease, replacing the bellows several times, and retesting—to achieve a leak rate of 50 ppm per day.

Continuing work over the next two years involved not only such problems as successfully machining a die through which to extrude the frames of the case, but also identifying a company capable of producing the extrusion at a reasonable cost and agreeing to carry it out. Finally, an aluminum window manufacturer in Ismailia, Egypt, agreed to produce the hot extrusion for approximately US\$20 per meter in large quantities. A sample of the product was sent to the GCI and it was found to be adequate, although it was not of the originally specified 6066 aluminum alloy. Then, with frames, corners, and other less complex components of the case at hand, it was possible to proceed with the assembly of several cases and to proceed to test their hermetic integrity.

For those planning to construct similar sealed cases, here are a few details of testing that may be of value, based on the experience reported here: It is useful

Figure 5.4

The author with the EAO's newly assembled hermetically sealed display cases in the Egyptian Museum. Photo by Shin Maekawa.

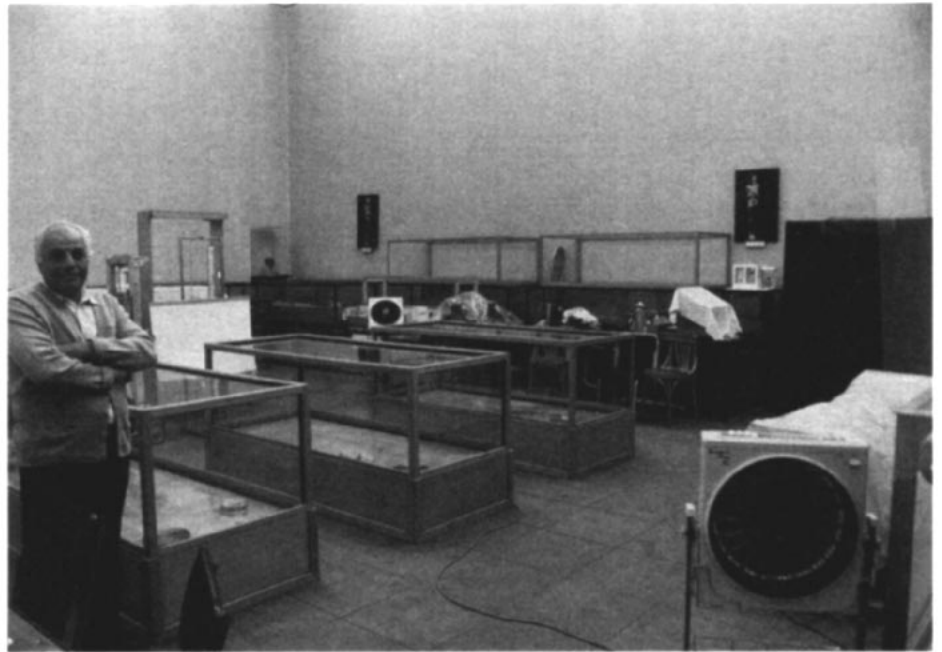

Figure 5.5

Photograph of the newly opened Royal Mummy Room (Room 56) in the Egyptian Museum. Photo by Shin Maekawa.

to install a small fan in the case and turn it on to eliminate any stratification just prior to circulation of the case atmosphere through the external oxygen analyzer. To avoid breakage of the glass panels of the case or, almost equally disastrous, deflection of the glass on the O-rings, one must be careful not to raise the internal pressure to more than 68 mm of water. (This slight pressurization is essential when employing the trace-gas-halogen leak detector, a useful test method recommended by Maekawa.) The other leak-test instrument, the oxygen analyzer, should not be exposed to air for long periods of time; it is best to keep oxygen-free nitrogen in the sensor compartment.

Simply looking at the state of inflation of the bellows provides a crude indication of leaks into the case. Because the bellows is left partially filled with nitrogen after air has been flushed from the case with nitrogen, if it is observed to be flat any time afterward, this indicates that there is a major leak in the bellows or in the case.

Finally, by November 1994, fifteen cases had been completed and, when tested, had a leak rate of less than 20 ppm of oxygen per day (Fig. 5.4). Each case was fitted with a hygrothermometer (donated by the GCI), visible from the exterior, in addition to the access cover and valves and bellows previously described. Activated carbon was placed in each case containing a mummy, although the modification did not allow space for silica gel packets for RH maintenance or for similar units of a scavenger to remove residual oxygen. The current plan is to complete a total of twenty-seven display cases for the refurbished Royal Mummy Rooms, which ultimately will contain all of the royal mummies.

## The Royal Mummy Rooms

Located in the east end of the Egyptian Museum, near the entrance to the Tutankhamen exhibit, the first of the completed Royal Mummy Rooms is on the second floor. A large area near the gates to this room is reserved for many displays related to mummification—from tomb objects to mummification tools to drawings from the Book of the Dead. Physically, the Royal Mummy Room (Fig. 5.5) has been made more attractive (while permitting concealment of air-

**Figure 5.6**

Photograph of members of the EAO team who built, tested, and installed the hermetically sealed display and storage cases for the Royal Mummy Collection at the Egyptian Museum. Photo by Shin Maekawa.



conditioning ductwork) by lowering its ceiling to 3 m, in contrast to the many rather austere 8 m high galleries in the museum. The floor size is 8 m x 13 m and, thus, with the low ceiling, marble floor and walls, and massive rectangular columns, the overall effect is one of an enclosed space remotely like a tomb, albeit an elegant one. That feeling is somewhat enhanced by the nearly concealed ceiling illumination provided by UV-filtered halogen spot lamps, individually controlled to limit the light on the mummies to less than 50 lux. The vitally important air-conditioning is maintained by three independent systems, two of which alternate each eight hours and one of which acts as a standby unit. The room's temperature is maintained at 21 °C day and night, and its relative humidity is controlled by a mobile dehumidifier, manually activated when the visitor load is high. Even when the air-conditioning malfunctioned occasionally during the initial use of the Royal Mummy Room, the RH and the temperature within the cases remained in the optimal ranges of 35-40% and 21-24 °C respectively.

The first Royal Mummy Room currently holds eleven mummies,<sup>1</sup> ten of them housed in hermetically sealed cases and one, Ramses II, in a French-built case. Long before they were transferred to sealed cases, the mummies had been in ordinary display cases where the average ambient relative humidity was in the 55% range. To prevent cracking of the skin or similar harm, the RH in the storage cases was slowly reduced, over a period of three months, to between 35% and 40%, the optimal level for long-term storage. The Supreme Council of Antiquities is planning to display an additional sixteen mummies in the second room.<sup>2</sup>

## Conclusion

Because of the remarkable original case design and the invaluable aid afforded by the GCI, together with a large investment of labor by others in Egypt, it has been shown that hermetically sealed cases can be constructed in countries that lack highly developed industrial facilities. The staff of the Egyptian Museum in Cairo look forward to the successful preservation of its entire Royal Mummy Collection and its presentation in the Royal Mummy Rooms to travelers from around the world.

## Acknowledgments

Individuals involved in the work included EAO advisers Shawky Nakhla and Mohammed Saleh; EAO members Ibrahim Ramzy, Asma El-deeb, Samia Emar, Soher El-Saoui, Gamal El-Bony, Sobhy Samoel, Hanan Nyroze, Mervat Resk, and Seham Shafek; and team members Aber Helmy, Khaled Ahmed, Mohammed Atia, Tarik Mohammed, Ashraf Abd-Elsamea, and Samy Abd-Elgany (Fig. 5.6).

## Notes

1. Mummies on display in Royal Mummy Room I, Room 56: Amenhotep I, Henuttawi, Merneptah, Queen Merytamun, Nedjemet, Ramesses II, Ramesses V, Seti I, Seqenenre Ta'a, Tuthmosis II, Tuthmosis IV.
2. Mummies to be displayed in Royal Mummy Room II, Room 52: Ahmes-Nefertari, Ahmose I, Amenhotep II, Amenhotep III, Esemkhebe, Ramses III, Ramesses IV, Ramesses IX or XII, Ramesses VI, Seti II, Siptah, Sitkamos, Tuthmosis I, Tuthmosis III, Queen Tiye, Yuya. The latter two mummies are from the nobility, rather than of royal birth.

## Chapter 6

# Preservation of the Original Documents of the Constitution of India

Hari Kishan and Shin Maekawa

The original documents of the Constitution of India (Fig. 6.1) comprise two bound calligraphed volumes in English and Hindi. Since their creation nearly four decades ago, both volumes have been housed in the Parliament Library in New Delhi.

The work of framing free India's Constitution commenced with the first meeting of the Constituent Assembly, held on 9 December 1946. After deliberating for nearly three years, the Constituent Assembly adopted the Constitution on 26 November 1949, and it took effect on 26 January 1950. The Constitution as originally adopted had twenty-two parts, comprising 395 articles and eight schedules. Its present text is amended from time to time. During the last forty-four years, there has been a total of seventy-five amendments.

At the insistence of then-Speaker Shri G. V. Mavalankar and then-Prime Minister Pandit Jawaharlal Nehru, the English version of the Constitution was prepared by an expert calligrapher, Shri Prem Bihari Narain Raizada of Delhi, who completed the task in about eighteen months. The document consists of 233 sheets of handmade parchment paper procured in England, measuring 45.7 cm by 58.4 cm, and weighing 13 kg. The handwritten pages were illuminated by the prominent artist Shri Nand Lal Bose of Shanti Niketan. Every page is beautifully embellished. At the beginning of each section of the Constitution, the illustrations by Shri Nand Lal Bose depict scenes from the Mohanjodaro and Vedic periods up through the time of India's Freedom Movement. The illumination process took about four years. For the Hindi version of the document, 264 sheets of handmade parchment paper, measuring 45.7 cm by 58.4 cm and weighing 14 kg, were made by the Hand Made Paper Research Centre, Pune, India. This document was penned by Shri Basantrao Vaidya, who also executed the decorations. The binding process took almost one year.

These documents have great autographic as well as historical value, because they contain the signatures of the founding fathers of the Constitution, many of whom subsequently played pivotal roles in shaping the destiny of the country.

### The Conservation Project

The important task of devising a solution for the long-term preservation of these historic volumes began in the mid-1980s and gained momentum after that time. To determine the state of preservation of the documents, the Parliament Library contacted the National Research Laboratory for Conservation of Cultural

Figure 6.1

The two bound volumes that contain the original documents of the Constitution of India. Courtesy of the Parliament House, Government of India.

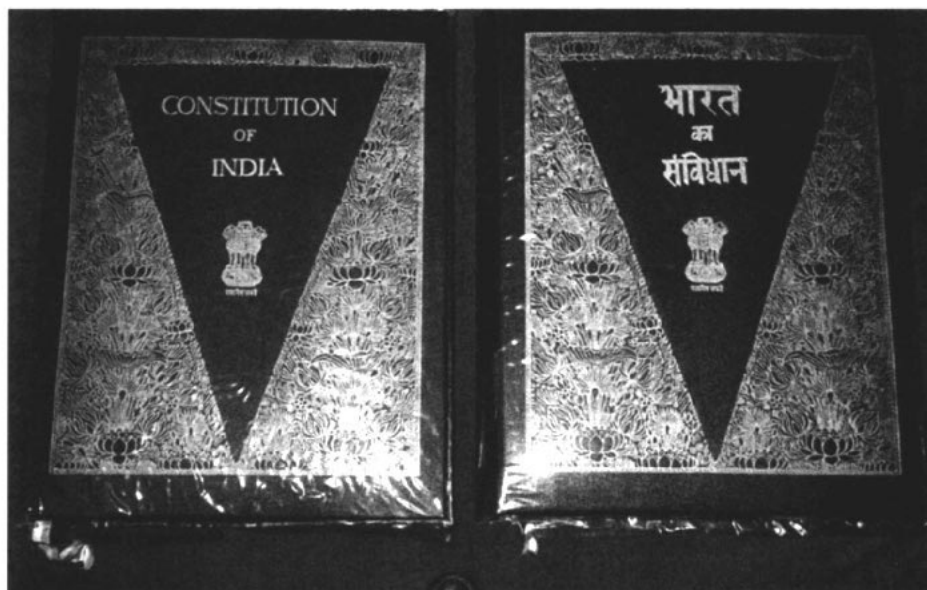

Property at Lucknow, India. Their report—which included the results of optical testing, the brightness of the paper, and the gloss of the gold on the document—concluded that both volumes were in fairly sound condition (National Research Laboratory 1994).

At the request of the Parliament Library, the National Physical Laboratory (NPL) in New Delhi began to develop a case for preserving the documents. The NPL developed the concepts of displaying and storing the documents in sealed glass cases with inert-gas atmospheres.

The most challenging aspect of constructing such a display case is producing an adequate seal. It must be hermetically tight and mechanically sound so as to withstand changes in temperature and atmospheric pressure. Other requirements of the seal are that it remain durable over many years and that it not allow contamination of the documents stored in the case. After an extensive literature search on the subject, three available methods for producing hermetic seals were identified and evaluated: silver-lead soldering, organic sealants, and mechanical seals using O-rings. From 1988 to 1989, the NPL fabricated cases using tempered-glass sheets and a silicone-rubber sealant. Apart from being esthetically inadequate, the cases were not satisfactory for two reasons: first, the durability of the seal over many years could not be assured; second, the organic polymeric materials from which the seals were made were found to emit volatile gases, which could have had an adverse effect on the contents of the case.

Simultaneously, extensive research efforts directed toward the development of a helium leak detector capable of measuring small quantities of air ingress into a helium-filled case were also made at the NPL. The instrument consisted of four fine platinum-tungsten coils and a Wheatstone network. Measurements over a period of about two years indicated that the system was reliable, rugged, and reproducible and could detect as small a change as 0.5% air ingress into a helium-filled case.

Several prototype glass cases were fabricated, and hermetic sealing was attempted using a soldering technique similar to the one developed by the U.S. National Bureau of Standards (now the National Institute of Standards and Technology) for the preservation of the Declaration of Independence and the Constitution of the United States (National Bureau of Standards 1951). Again, however, acceptable seals were extremely difficult to produce. At this stage, various national and international institutes and laboratories were contacted for assistance.

Through the courtesy of the French Embassy in New Delhi, Hari Kishan of the National Physical Laboratory visited France from September 1992 to February 1993 to obtain technical aid in the development of hermetically sealed glass cases. During this period, two cases—one sealed by the soldering process (Fig. 6.2) and the other with O-rings (Fig. 6.3)—were constructed with support provided by the Saint-Gobain Company, Paris. It was concluded from this investigation that for the long-term preservation of the Constitution, the O-ring sealing technique was far superior to the soldering method because of the difficulty of consistently producing a secure soldered seal.

During this period, it was suggested that Kishan contact the Getty Conservation Institute to obtain technical assistance in the O-ring sealing technique. In November 1992, a request for assistance was made to the GCI.

### **Collaboration Between the NPL and the GCI**

In response to the NPL's request, the GCI sent a report on the royal mummy conservation project, which had been carried out in collaboration with the Egyptian

Figure 6.2  
Hermetically sealed glass case, sealed  
by soldering. Photo by Shin Maekawa.

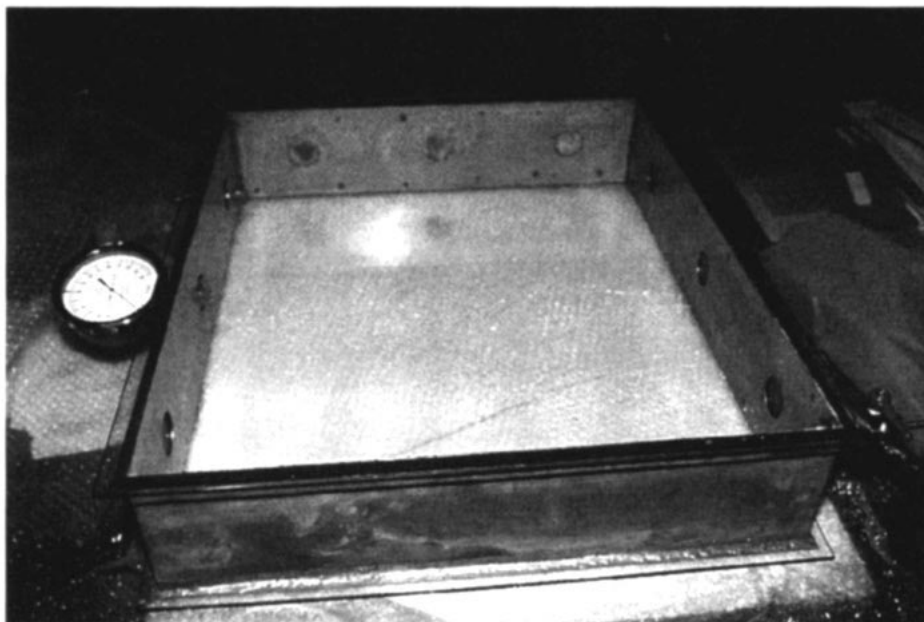

Antiquities Organization (Maekawa and Lambert 1993). The report contained the concept and design details of the GCI's hermetically sealed display and storage case. Shortly after the report was sent, the GCI offered to construct the cases for the Constitution of India, provided that the cases would be used to house these culturally and historically important documents. A letter of intent between the NPL and the GCI was signed in July 1993. It detailed plans to collaboratively design, install, and test the Institute's hermetically sealed cases, which would be fabricated for the preservation and display of the constitution documents.

### Design and Fabrication of the Cases

The following are edited portions of the agreement between the NPL and the GCI regarding the cases for the Constitution of India:

1. Two identical cases will be fabricated, one for the English and the other for the Hindi version of the document.
2. The internal volume of each case will be 96,250 cm<sup>3</sup>, and the dimensions of each will be 55 cm wide, 70 cm long, and 25 cm high.

Figure 6.3  
Hermetically sealed glass case, sealed  
by O-rings. Photo by Shin Maekawa.

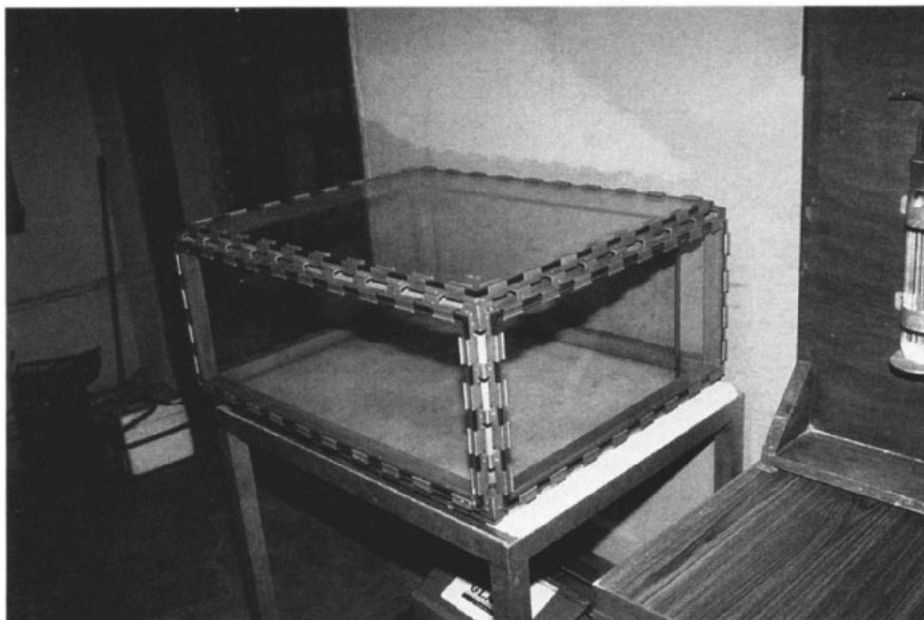



Figure 6.4

Mechanical drawing of the baseplate of the display case designed by the GCI.

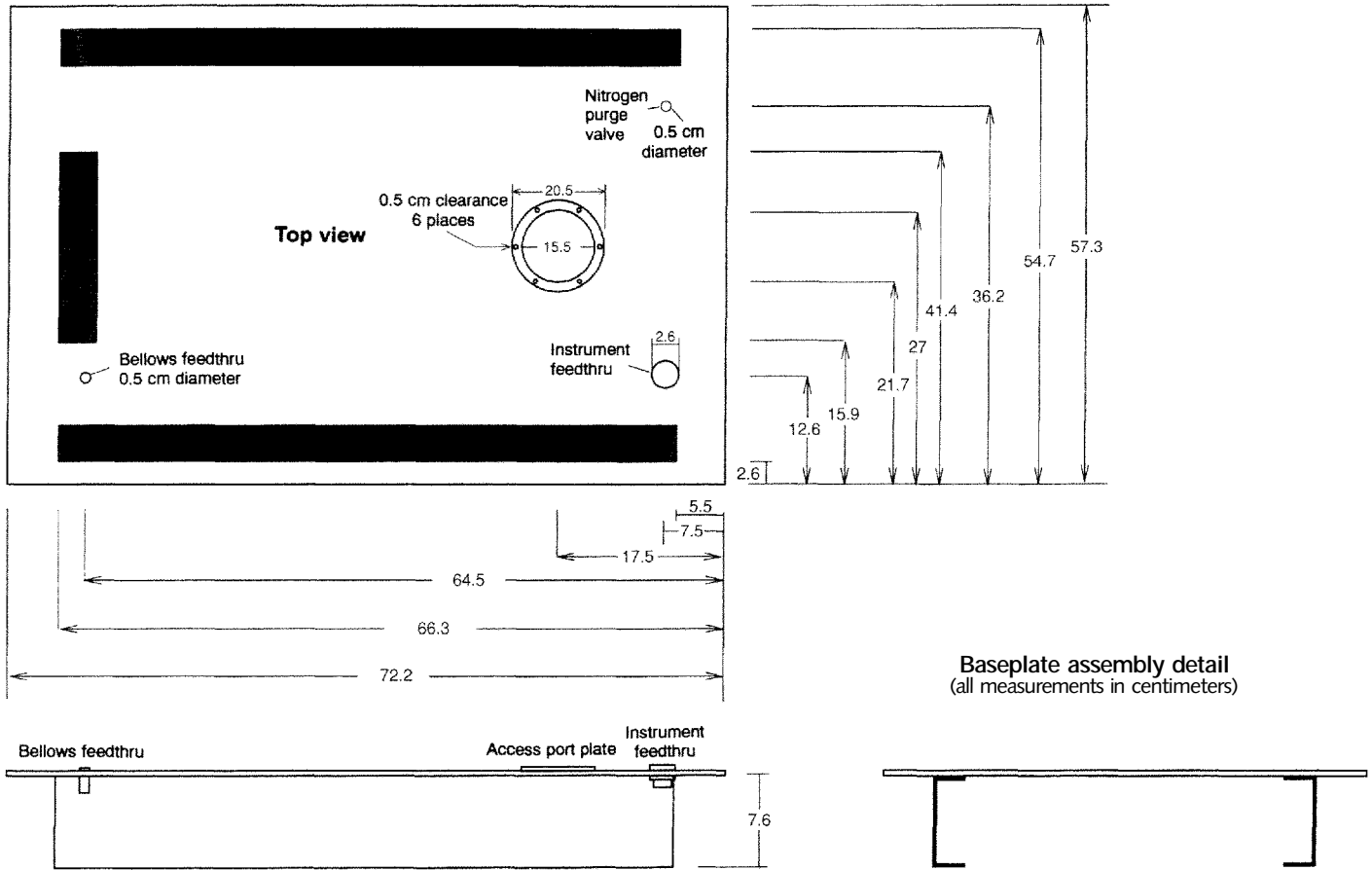

Figure 6.5  
Photograph of cases built at the GCI, Photo by Shin Maekawa.

3. The documents will be stored and maintained at a relative humidity of 40-50% in a nitrogen atmosphere with an oxygen concentration of less than 1% by volume.
4. A special protective vaultlike room, 180 cm wide, 180 cm deep, and 305 cm high will be constructed in the Parliament Library at the Parliament House for display and storage of the documents. The room will be climate controlled to maintain a temperature of  $20\text{ }^{\circ}\text{C} \pm 2\text{ }^{\circ}\text{C}$  and a  $30\% \pm 5\%$  relative humidity throughout the year.

It was also agreed that the cases would be constructed at the GCI in the United States and transported to the Parliament Library in New Delhi, where they would be installed and jointly tested by the GCI and the NPL.

Based on the above requirements, the GCI staff prepared a set of mechanical drawings of the cases, and three identical cases were simultaneously fabricated in the machine shop of the GCI (Fig. 6.5). A total of 120 work hours were spent by GCI's master machinist on the project. Three cases were built, and after brief oxygen-leakage testing, two of them were crated and transported to New Delhi for installation in the Parliament Library in March 1994.

### Installation of the Display and Storage Cases

Because of a delay in the construction of a Parliament Library building where the proposed vaultlike room for the Constitution was to be located, the cases were temporarily installed in a small side room attached to a central meeting room in the Parliament Library at the Parliament building for in situ performance testing

**Figure 6.6**

Cases displaying the Constitution of India, temporarily installed in a small side room of the Parliament Library, New Delhi. Photo by Shin Maekawa.



(Fig. 6.6). The room is on the second floor of the massive, toroidal three-story building, which is made of large blocks of red Indian sandstone. Although the room is not climate-controlled, the architecture of the building and the location of the room provide a comfortable and stable environment throughout the year. The average temperature is 30 °C in summer and 20 °C in winter.

The cases were individually mounted on polished stainless steel bases, approximately 1 m in height, with varnished teak cabinetwork that covers the metal frames of the cases. The bases and cabinets were constructed at the NPL. A trace-oxygen analyzer connected to a datalogger was installed in each nitrogen-filled case for monitoring oxygen leakage into it during performance evaluation. The cases were initially flushed with dry nitrogen, and the oxygen content was reduced to below 1000 ppm. The amount of oxygen leaking into the cases was 5 cm<sup>3</sup> (50 ppm) over a seven-month period for one case, and 109 cm<sup>3</sup> (1130 ppm) over a three-month period for the other. Appropriate amounts of an oxygen scavenger (Ageless) will be placed in the cases to keep the oxygen level as low as required. The performance of the cases was accepted by both the NPL and the GCI.

### Summary

Two hermetically sealed, inert-gas-filled display and storage cases were designed and fabricated by the GCI to preserve the Constitution of India. The cases were successfully installed in a non-air-conditioned room in the Library of the Parliament House in New Delhi. After one year of joint testing in situ by the library, the NPL, and the institute, the cases have been accepted as effective for the conservation and display of the Constitution of India.

The cases are designed to maintain a nitrogen microenvironment of less than 1% oxygen concentration at 45% relative humidity (RH) for a minimum of twenty years without the support of a mechanical or electrical subsystem or maintenance. This microenvironment has been chosen to prevent oxidation, biological and microbiological deterioration, and air-pollution damage to the document.

The ceremonial placement of the Constitution of India took place on 27 October 1995.

## Acknowledgments

The authors wish to thank Miguel Angel Corzo, director, and Neville Agnew, group director, Information and Communications, of the Getty Conservation Institute for their direction and encouragement of the project. Thanks also to E. S. R. Gopal, then-director of the National Physical Laboratory (NPL); and A. P. Jain, then sub-director of the NPL, for their contributions. The authors also wish to acknowledge the participation of the following individuals at the GCI: Jim Davies, machine shop supervisor; Frank Lambert, consultant; Kevin Fennelly, student intern; and Vinod Daniel, former research fellow.

The National Physical Laboratory wishes to acknowledge the following individuals for their contributions: S. K. Joshi, former director of the NPL; O. P. Agrawal and I. K. Bhatnagar, former directors of the National Research Laboratory for Conservation of Cultural Property, Lucknow, India; D. G. Suryawanshi, senior scientific officer of the National Research Laboratory; Georges Amsel, Laboratoire de Physique des Solides, Jussieu, Paris; P. Averbuch, Centre National de la Recherche Scientifique (France), Grenoble; Regis Ballestracci, former deputy scientific counselor of the French Embassy in New Delhi; K. S. Bhandari, scientist, Forest Research Institute, Dehradun; R. C. Bhardwaj, the Secretary General; A. N. Kaul, G. C. Malhotra, and S. K. Sharma, former directors, John Joseph, director, and R. K. Chadha, joint director, Parliament Library, New Delhi; J. Claude Lehmann, research director, Janes L. Barton, technical director, and their highly efficient team at Saint-Gobain, Paris; J. M. Pierrard, director, Paper Research Institute, Grenoble; and Chandru J. Shahani, preservation research officer of the Library of Congress, Washington, D.C.

## References

**Maekawa, S., and F. Lambert**

1993

*The Getty Conservation Institute's Inert Atmosphere Display and Storage Cases for the Pharaonic Mummies of the Egyptian Museum, Cairo.* Marina del Rey, Calif.: The Getty Conservation Institute.

**National Bureau of Standards (NBS)**

1951

*Preservation of the Declaration of Independence and the Constitution of the United States.* Washington, D.C.: NBS.

**National Research Laboratory for Conservation of Cultural Property**

1994

Report on the condition of the Constitution of India, prepared for the Parliament Library, Lucknow, India, September.

# Preservation of the Mummy of an Egyptian Child in a Hermetically Sealed Museum Case in Spain

Shin Maekawa

In the 1860s, Eduard Todà i Güell, the premier Catalan archaeologist of the period, was attached to the Spanish Consulate in Cairo and working on projects cooperatively with Egyptian authorities. In 1866, he was urged by Gaston Maspero, his personal friend and the director of the Antiquities Service of Egypt, to excavate the tomb of Sennedjem at Deir el Medina in Thebes (Belascoain and Trullen 1995). Although Sennedjem had not been a person of pharaonic rank, this tomb was of particular significance because it was found to be intact and quite untouched by millennia of tomb robbers. Thus, during his careful excavations, Todà was able to discover invaluable information about details of the funeral rituals of the New Kingdom, which are essential even today. From the excavated objects, he assembled a collection of Egyptian antiquities that was donated to the Biblioteca-Museu Víctor Balaguer in Vilanova i la Geltrú, Spain, and the Archeological Museum in Madrid. Part of the collection in the Biblioteca-Museu is the mummy of a five-year-old child (25 cm wide and 83 cm long), named "Nesi."

In 1886, Nesi was displayed in a glass case typical of the period (Fig. 7.1), in the Egyptian collection of the Biblioteca-Museu (Belascoain and Trullen 1995). Moved to another, similar case sometime in the last century, Nesi was again transferred in 1988, this time to a custom-designed glass case with a massive marble base (Fig. 7.2). The beauty of the new display hid several flaws: besides continuing to be supported on a moisture-retaining cotton cushion, Nesi was illuminated by a UV-rich fluorescent light directly above the case and thus was unintentionally exposed to a new threat: photooxidation of the linen wrappings of the mummy, which greatly increased their fragility.

In addition, during movement of this case, signs of insect infestation and a fungal growth were noted on the mummy. Unfortunately, at this time, in the 1980s, there was a lack of consensus among Egyptologists in the world community about the best methods of coping with such problems and of ensuring the long-term preservation of mummies. Extended search of then-current and past literature on the subject and many discussions with others gave Elena Bolívar, the conservator of the museum, no decisive course to follow. Finally, in 1991, she was able to consult with Nieves Valentín, the research biologist at the Instituto de Conservación y Restauración de Bienes Culturales (ICRBC) of the Spanish Ministry of Culture for an evaluation of these problems and for their solution. From 1987 to 1989, while working as a research associate at the Getty Conservation Institute, Valentín had been involved in studies dealing with insect and other microbiological controls using inert-gas atmospheres. On her return to

Figure 7.1

Child Egyptian Mummy, Nesi, in display at the Biblioteca-Museu Víctor Balaguer, Vilanova i la Geltrú, Spain. Courtesy of Biblioteca-Museu Víctor Balaguer.



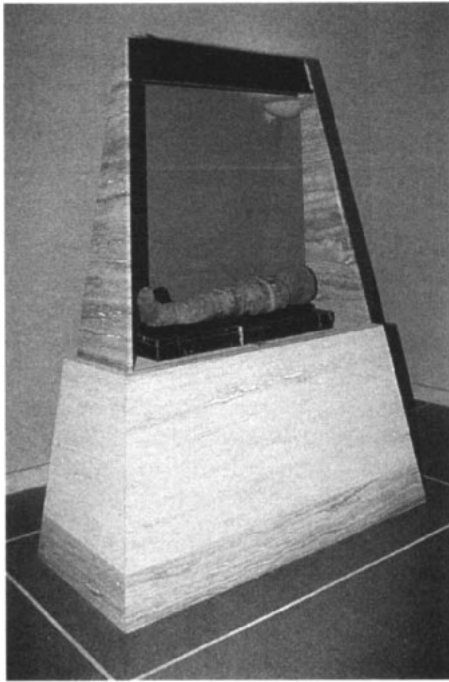

Figure 7.2  
Nesi in the custom-designed display case,  
showing biodeterioration (Valentín 1994).  
Photo by Nieves Valentín.

Spain, she had extended the research and implemented the findings in several museums and libraries in Spain, and in Central and South American countries, with marked success.

## Conservation Treatments

After a survey of the mummy and the display environment, Valentín immediately had the mummy, without its moist cushion, transferred to a large plastic bag, made from an oxygen-barrier film, through which a continuous flow of argon was passed (Valentín 1992). By using this virtually oxygen-free environment over the initial test treatment period of five weeks, she was successful in stopping the infestation and reducing the overall microbiological activity on the mummy. For the next two years, the bag was purged weekly with argon to maintain the oxygen content below 500 ppm while the relative humidity was kept at about 45% (Valentín 1994). For permanent maintenance of the argon environment, and so the mummy could again be displayed to the public, Valentín recommended that the museum contact the GCI about obtaining a GCI-designed hermetically sealed display and storage case for Nesi.

## Fabrication of the Case

Following discussions with the GCI, the Biblioteca-Museu agreed to search for a local display case manufacturer to coordinate the fabrication and installation of the case. The GCI offered to provide free consultation throughout the project, in the confident belief that any skilled display-case producer could fabricate the case, given proper guidance. In addition, the GCI considered it to be especially important for a Spanish institution to develop the competence to produce (or to arrange for the production of) the hermetically sealed case because ethnographic museums both in Madrid and in the Spanish Canary Islands own several important mummies native to the islands (Guanches mummies, as they are known), as well as Egyptian mummies. Clearly the preservation of these mummies is of great national cultural importance, and their maintenance in an inert-gas atmosphere is a superior method for achieving this goal.

Additional reasons for having the sealed case made in Spain were the increased cost and possible serious damage in transport if it were fabricated in the United States and then shipped to Spain. Although the case is adequately sturdy in a normal static state on display or in storage, the possible stresses that can occur in commercial, unguarded shipment could permanently damage some of its members so that a hermetic seal could never be regained. Further, because skilled labor would be required for the installation and in situ testing of the case at the Biblioteca-Museu, it was thought advisable that the persons actually responsible for constructing the case be involved in its careful local transport and final setup. The experience of the Biblioteca-Museu should be valuable in the future to all those museums needing to manufacture such cases in Spain and potentially useful elsewhere.

In January 1993, Elena Bolívar of the Biblioteca-Museu discussed the local production of a GCI-designed hermetically sealed case with Joan Ramon Aromí Folch of Metode Company, a Barcelona firm that prepared and installed museum exhibits. Metode agreed to coordinate the project (Aromí Folch 1994; Aromí Folch and Argemí Torras 1996) and—after extensive negotiations with several organizations, principally the Serveis Científics Tècnics de la Universitat de Barcelona (SCTUB), an industry-university collaborative group of the University of Barcelona—it finalized a contract with all parties in September 1993. The SCTUB would machine some of the metal components, obtain others, fabricate the bellows, assemble and test the airtightness of the case and its accessories, and install it in the museum. A local exhibit designer would be responsible for

the aesthetic design of the sealed case, including its base. The final plan produced by the designer is shown in Figure 7.3.

The major challenges in case construction arose from the need for precision in the manufacture of the metal components of the frame and in their assembly with the glass faces. This precision is required for a near-perfect seal with the Viton O-rings on which the glass is held to the frames (including their corners) by spring (pressure-retention) strips. To ensure exact placement of the O-rings and ready retention of them during assembly, the frames are made from aluminum extrusions with a custom-designed cross section. Each of the eight corner elements is novel in that it can be bolted to three frame components while providing smoothly connected surfaces for the O-rings of the adjacent glass faces. To help expedite the project, the GCI provided the machined corner elements for the case as well as all needed engineering drawings and descriptions of assembly and testing.

To produce the die that could extrude aluminum with the cross section needed for the case frame would have cost more than US\$2,000 if the work had been done in Barcelona. (The GCI has underwritten the cost of an extrusion die and as of 1996 the GCI can recommend a U.S. source that will inexpensively manufacture the extrusion.) In 1990-91, however, the Egyptian Antiquities Organization (now the Supreme Council of Antiquities) had purchased a large volume of the extrusions from an aluminum-window manufacturer in Egypt for its use in constructing a GCI-designed hermetically sealed case for the Royal Mummy Collection at the Egyptian Museum in Cairo, and the EAO had extra extrusions for sale. Therefore, Aromí Folch was able to go to Cairo and purchase the needed extrusions.

With these critical components in hand, Evelio Lantigua and Ferran Vilardell of the SCTUB group were ready in early 1994 to combine them with other necessary units they had fabricated or purchased in Barcelona. These included the aluminum bottomplate (with a large access port and several small tubing ports for inert-gas entry and exit, and for bellows connections, as indicated in Fig. 7.3), the glass sides and top, the Viton O-rings, and the essential retention strips that were screwed to the frames and provided the pressure to hold the glass faces tightly to the O-rings. The case's exhibition designer provided a hidden compartment in the base of the finished display so the bellows and the oxygen monitor

**Figure 7.3**  
Drawing of the exhibit design of the proposed hermetically sealed display and storage case at Biblioteca-Museu Víctor Balaguer (Aromí Folch 1994).

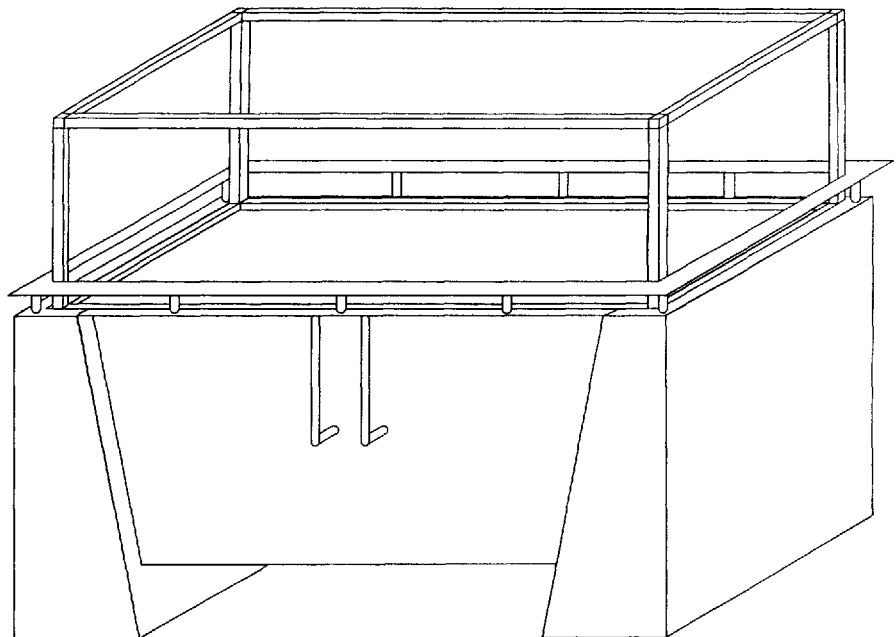

would be invisible. The control panel for valves and humidification apparatus (described in the following paragraph) were similarly concealed in the base of the final display.

Because argon gas is available only with an extremely low moisture content, and Valentín had recommended that the mummy be kept in an environment whose relative humidity level was about 45%, the argon to be used for flushing the case had to be humidified to that level. This was achieved by a two-vessel system, as shown in Figure 7.4. Valve 2 was adjusted so the flow of dry argon would mix with that of the nearly saturated argon coming from the vessel of water at the right to result in a 45% relative humidity level, as indicated by the RH sensor in the mixing chamber.

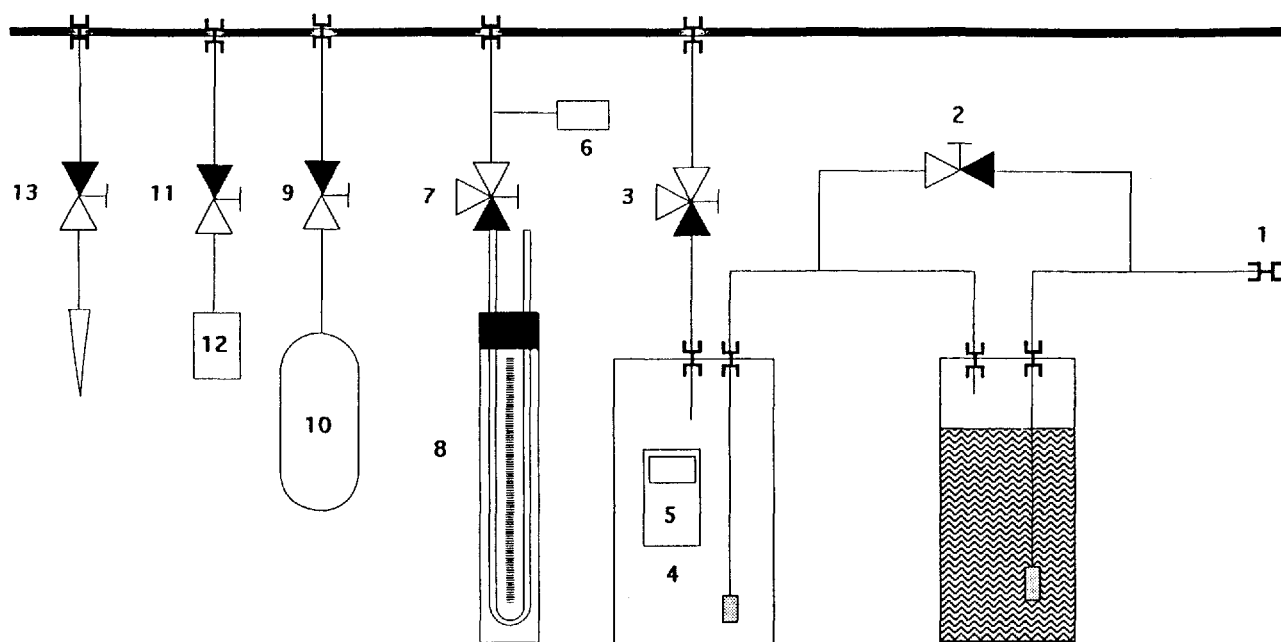

Figure 7.4

Schematics of attachments to hermetically sealed case's bottomplate (Aromí Folch 1994)

- |                            |                          |                               |
|----------------------------|--------------------------|-------------------------------|
| 1 = Nitrogen source        | 6 = Security valve       | 11 = N <sub>2</sub> out valve |
| 2 = Humidity control valve | 7 = Three-way ball valve | 12 = Microfilter              |
| 3 = Three-way ball valve   | 8 = Manometer            | 13 = Samples access           |
| 4 = Mixing chamber         | 9 = Bellows valve        |                               |
| 5 = HR sensor              | 10 = Bellows             |                               |

An essential aid to the testing of the completed, sealed case and its accessories was the loan of a trace oxygen analyzer by the ICRBC. The case was designed to have a percent oxygen monitor, which has a resolution of 0.1%, at the range between 0% and 25%, for monitoring the oxygen concentration in the case while being used for display. However, it was necessary to use a trace oxygen analyzer, which has a resolution finer than 10 ppm (0.001%), during the determination of the leak rate at the installation. Purchasing the analyzer would increase the project cost by US\$10,000 (in the United States, as of this writing, trace oxygen analyzers cost \$4,000 to \$5,000) and the project would not be able to support it. Leak testing by other techniques, such as halogen leak detectors, can indicate only points of major leakage, not the extremely small amount of oxygen leaking into the case per day that must be determined if the long-term performance of the case is to be predicted.

As with any complex project, there were technical obstacles to be overcome, but the effective collaboration of individuals in the several organizations involved resulted in a case that fulfilled the original goals. After extensive testing, on 17 November 1994, the completed 384 I sealed case (55 cm high, 155 cm long,

and 45 cm wide) was installed in a non-air-conditioned storage building of the museum while the museum was being renovated. Before the mummy was transferred to this case, a conservator from the ICRBC had treated the mummy's linen wrappings and polychrome papyri (Herráez Martín 1994).

To present the project and discuss the use of inert-gas atmospheres for the preservation of mummies and other organic objects, a roundtable discussion was organized at Fundació Joan Miró in Barcelona by the foundation, Biblioteca-Museu Víctor Balaguer, the ICRBC, and Metode. Approximately eighty museum professionals from both Spain and Portugal were in attendance, an indication of the widespread interest in the subject and in the approach used by the participants in the project.

Figure 7.5

The Spanish-built, hermetically sealed display and storage case for the child mummy, Nesi, in the Egyptian gallery at Biblioteca-Museu Víctor Balaguer.



Upon completion of the remodeling of Biblioteca-Museu Víctor Balaguer in early 1996, the hermetically sealed display case containing Nesi was reinstalled in the Egyptian gallery for permanent display (Fig. 7.5). It has an argon atmosphere at 45% RH, and its performance is being determined by an oxygen monitor. The case has been meeting the criteria for an excellent sealed unit, in that it has had

Figure 7.6

Members of the project team shown in front of the Spanish-built, hermetically sealed display and storage case for the child mummy, Nesi, in the storage building of Biblioteca-Museu Víctor Balaguer.





a leak rate of less than 4 ppm of oxygen per day since the installation. Twenty packets of the Ageless Z-2000 oxygen scavenger (40,000 cc oxygen absorption capacity) will be placed in the case, along with 10 kg of silica gel that has been conditioned at 45% RH and 100 g of activated carbon, for 70 years of maintenance-free display in the museum.

## Acknowledgments

The following people participated in the project: Josep Maria Trullen, director of Biblioteca-Museu Víctor Balaguer; Ricard Belascoain, curator of Biblioteca-Museu Víctor Balaguer; Elena Bolivar, conservator of Biblioteca-Museu Víctor Balaguer; Nieves Valentín, research biologist at the ICRBC; M. Isabel Herráez Martín, conservator at the ICRBC; Joan Ramon Aromí Folch, Metode Company; Ricard Andres, aesthetic designer for the case; and Evelio Lantigua and Ferran Vilardell of the University of Barcelona. Figure 7.6 shows these members of the project.

## References

**Aromí Folch, Joan Ramon**

1994

Adaptation of a showcase prototype design of the Getty Conservation Institute. Internal report. Metode Company, Barcelona, Spain, November.

**Aromí Folch, Joan Ramon, and Montserrat Argemí Torras**

1996

Adaptation of a prototype showcase design in the Getty Conservation Institute, control of biological activity with an atmosphere of inert gas. Report, HC-Spain, November.

**Belascoain, Ricard, and Josep Maria Trullen**

1995

Letter to the author. Biblioteca-Museu Víctor Balaguer, Vilanova i la Geltrú.

**Herráez Martín, M. Isabel**

1994

Informe sobre el trabajo de conservación preventiva realizado en una momia egipcia. Internal report. Instituto de Conservación y Restauración de Bienes Culturales, Madrid, December.

**Valentín, Nieves**

1992

Contaminación biológica y tratamiento de la momia egipcia perteneciente al Museo Balaguer de Vilanova i la Geltrú. Internal report. Instituto de Conservación y Restauración de Bienes Culturales, Madrid, December.

1994

Análisis de contaminación biológica de una momia egipcia del Museo Balaguer expuesta a atmósferas inertes. Internal report. Instituto de Conservación y Restauración de Bienes Culturales, Madrid, December.

# Index

## A

Abe, Y., 37  
acid, in cellulose, 9  
acridine orange, 23  
*Actinomyces* sp., 20, 21f, 24, 25f  
"Action of Light on Water Colors" (Russell and Abney), 7  
activated carbon, 50  
aerobic organisms, control of, 20-21  
Ageless, 35-37, 39f, 40, 57  
    reaction rates of, 3  
Agnew, N., 5  
Ajie, H., with Sobel, 10  
alcohol, 17  
Algueró, M., 19  
    with Valentín, 17  
aluminized polyethylene, 34  
aluminum rods, in display case construction, 33  
aluminum-plastic bellows, 39f  
ammo acid analysis, 10  
anaerobic organisms, 21-23  
animal skin. See parchment  
Anobiidae, 18  
*Anobium punctatum*, 18, 19f, 20f  
Argemí Torras, M., with Aromí Folch, 60  
argon anoxia, 18, 20f, 24, 26, 62  
Arney, J. S., 9  
Aromí Folch, J. R., 60  
Artsorb, 37  
*Aspergillus flavus*, 20, 21f  
*Aspergillus niger*, 20, 21f  
*Aspergillus* sp., 24, 25f  
*Attagenuspiceus*, 18, 19f

## B

*Bacillus* sp., 20, 21f, 24, 25f  
bacterial growth, 17  
    control of, 19-23  
Bailey, S. W., 17  
Banks, H. J., with Bailey, 17  
Barraco, R. A., 11  
Belascoain, R., 59  
bellows, 3-4, 31, 34-35, 39f, 43  
Biblioteca-Museu Víctor Balaguer,  
    Spain, 23  
    mummy display case for, 59-64  
Bogaard, J., with Whitmore, 8  
Bolívar, E., 59, 60  
Bose, Shri N. L., 53  
Bouchard, J., with Zou, 8  
Brommelle, N. S., 7  
Brown, D., with Passaglia, 8, 31  
Bulst, W. A., 8  
Burton, D. M. B. E., 10  
butyl, 31

## C

Cairo, environmental conditions of, 1  
Calmes, A., 10  
carbon dioxide fumigation, 18  
cellulose  
    deterioration of, 8-9  
    oxygen-free environment for, 7-8  
Cerambycidae, 18  
Charters of Freedom of the United States,  
    storage of, 7-8, 10  
chromatography, 10  
cigarette beetle, 18  
climate controls, 31  
collagen  
    deterioration of, 9-10  
    and humidity, 12  
    oxygen-free environment for, 7-8  
    preservation of, 9  
color fading, 9  
    light and, 7  
Constitution of India, 53f  
    description of, 53  
    display case for, 53-58, 55f, 56f, 57f  
        backplate of, 56f  
        and collaboration between NPL and GCI,  
            54-55  
    construction of, 54  
    design of, 55-56  
    fabrication of, 55-56  
    installation of, 56-57  
        with O-ring seal, 55f  
Constitution of Puerto Rico, storage of, 8  
Constitution of the United States, storage of,  
    7-8, 10  
*Cryptotermes brevis*, 18

## D

*Daedalea biennis* Fries, infestation of  
    Ramses II mummy, 1  
Daniel, V.  
    with Hanlon, 18  
    with Lambert, 37  
David, A. E., 8  
Dead Sea Scrolls  
    deterioration of, 10-11  
    preservation of, 10  
Declaration of Independence, storage of,  
    7-8, 10  
Dermestidae, 18  
Derrick, M., 10  
deterioration  
    case studies of, 9-12  
    causes of, 1  
    of cellulose, 8-9  
    extent of, 10-11  
    inert gases for control of, 17-29

in presence of oxygen, 8-9  
protection from, by oxygen reduction, 7-15  
of Whatman filter paper, 8  
Dickens, B., with Passaglia, 8, 31  
display and storage case, hermetically sealed  
bellows of, 34-35  
bottom plate of, 38f  
construction of, 33-39  
corner assembly, 36f  
corner element, 35f  
design and construction of, 31-45  
design concepts for, 32  
display section of, 33-34  
evaluation of, 40-41  
extrusion end, 36f  
extrusion profile, 34f  
general description of, 32-33  
hermetic seal of, 37f  
installation of, 40-41  
leak testing of, 40  
materials and suppliers for, 42-43  
for Nesi, 59-64  
oxygen scavengers in, 35-37  
passive control agents, 35-39  
pollution sorbent of, 39  
prototype of, 32f  
purging of, 40-41, 41f  
recommendations for, 49-50  
relative humidity buffer of, 37-39  
retention strip of, 38f  
for Royal Mummy Collection, 47-52  
di-tyrosine, in parchment, 10  
Donahaye, E., 17  
*Drosophila melanogaster*, 18  
drugstore beetle, 18  
dyes, fading of, 9  
dynamic system, 31

## E

EAO. See Egyptian Antiquities Organization  
Egyptian Antiquities Organization (EAO), 2,  
20, 47, 51f, 61. See also Supreme  
Council of Antiquities  
Egyptian Museum, Cairo, 47, 47f  
Royal Mummy Collection of, preservation  
of, 1-5, 11  
Royal Mummy Room of, 47f, 50f, 50-51, 52  
closing of, 1-2  
Ewert, K., with Maekawa, 40  
Emancipation Proclamation, storage of, 8  
ethylene oxide, 17  
ethylene vinyl alcohol-laminated film, 34

## F

Feller, R. L., 7, 8, 9  
fibroin, 9

Filmpak 1193, 34  
Fleurat-Lessard, F., 17  
Florian, M. L. E., 17  
France-Lanord, A., 8  
with Salins, 8  
fumigants, 17  
Fundació Joan Miró, 63  
fungal growth, 17  
control of, 19-23  
furniture beetle, 18

## G

Gallo, F., 21  
gamma radiation, 17  
gasket technology, 31  
Gates of Paradise, preservation of, 8  
GCI. See Getty Conservation Institute  
Getty Conservation Institute (GCI)  
biodeterioration studies, 17  
collaboration with National Physical  
Laboratory, 54-55  
and Egyptian Mummy Collection, 2, 3  
and fungal/bacterial control, 20-21  
and parchment preservation, 10  
Ghiberti, Gates of Paradise by, 8  
Gifford, J., with Pääbo, 17  
Gil-Av, E., with Weiner, 10  
Gilberg, M., 18  
Ginell, W. S., with Schilling, 10  
Grosjean, D., with Parmar, 39  
guanches mummies, 60  
Guell, E.T., 59  
Gurnagul, N., with Zou, 8

## H

Hanlon, G., 18  
Hansen, E., 3, 9, 10, 11, 23  
with Sobel, 9  
Hariri, F., with Sobel, 9  
helium, effect on parchment, 8, 10  
Herráez Martín, M. I., 63  
Heuser, E., 8  
Hewlett, M. J., with Sobel, 9  
histidine, in parchment, 10  
Hoshino, J., with Nakamura, 17  
house longhorn beetle, 18  
humidity, 3. See also relative humidity  
Hutchinson, F., 17  
*Hylotrupes bajulus*, 18, 19f, 20f

## I

ICRBC. See Instituto de Conservación y  
Restauración de Bienes Culturales  
inert gases  
for biodeterioration control, 17-29  
dynamic system with, 31  
static system with, 31

- insect pests, control of, 17-29  
 Instituto de Conservación y Restauración de Bienes Culturales (ICRBC), 17, 59  
 Instituto del Patrimonio Histórico Español, 3, 17  
 iron oxide, and color fading, 9  
 Iskander, N., with Nakhla, 1  
 Israel Museum, 10
- J**  
 Jacobs, A. J., with Arney, 9  
 Jay, E., with Navarro, 17
- K**  
 Kanagy, J. R., 8  
 Kenjo, T., 9, 17  
 Kennedy, J., with Rust, 1, 18  
 Kishan, Hari, 54  
 Koestler, R., 9, 17, 18  
 Kondoh, Y., with Abe, 37  
 Kowalik, R., 19  
 Koyano, M., with Toishi, 31  
 Kuhn, H., 7  
 Kustanovich, Z., with Weiner, 10
- L**  
 Lambert, F., 5, 37  
     with Maekawa, 26, 31, 55  
 Lantigua, E., 61  
*Lasioderma serricorne*, 18, 19f, 20f  
 lead oxide, and color fading, 9  
 leak testing, of display and storage case, 40  
 Leary, G. J., 9  
 leather, deterioration of, 8  
 Lee, S., with Hansen, 10, 23  
 Library of Congress, 10  
 light  
     and color fading, 7  
     effects of  
       on cellulose, 8-9  
       on organic materials, 3  
       in vacuo, 7  
 Lightsense Corp., 4  
 lignin, deterioration of, 9  
 Lindstrom, M., with Valentín, 1, 10  
 litharge, fading of, 9  
 Lyctidae, 18  
*Lyctus brunneus*, 18, 19f
- M**  
 Maekawa, S., 26, 31, 40, 55  
     with Hanlon, 18  
 Martin de Hijas, C., 19  
     with Valentín, 17  
 Marvelseal 360, 34  
 Maspero, G., 59  
 Mavalankar, Shri G. V., 53  
 el Medina, S. D., 59  
 mercuric sulfide, and color fading, 9  
 Merovingian belts, storage of, 8  
 Merovingian helmet, storage of, 8  
 metals  
     oxygen-free environment for, 7-8  
     preservation of, 8  
 methionine, in parchment, 10  
 methyl bromide, 17  
 Metode Company, 60  
 Mitsubishi Gas Chemical Co., 37  
 molecular sieves, 37  
*Mucor*, 24, 25f  
 mummies. *See also* Egyptian Museum, Cairo; Nesi; Royal Mummy Collection  
     biodegradation control of, case study, 23-26, 24f, 25f, 26f  
     fungal and bacterial infestation of, control of, 20-23, 21f, 22f, 23f  
     preservation of, 9, 11  
     rehydration of, 11  
     storage of, 8  
     water-absorption curves of, 11  
 Musée Archéologique of Strasbourg, 8  
 Musée de l'Homme, Paris, 1  
 Museo Opificio del Pietre Dure, Florence, 8
- N**  
 Nakamura, H., 17  
 Nakhla, S., 1  
 Nakht Rom I, mummy of, 11  
 National Bureau of Standards (NBS), 7-8, 10, 31, 54  
 National Gallery, London, 7  
 National Physical Laboratory (NPL), 54  
     collaboration with Getty Conservation Institute, 54-55  
 National Research Laboratory for Conservation of Cultural Property, 53-54  
 Navarro, S., 17  
 NBS. *See* National Bureau of Standards  
 Nehru, P. J., 53  
 Nesi  
     conservation treatments for, 60  
     display case for, 59f, 59-64  
       argon in, 62  
       bottomplate attachments to, 62f  
       construction of, 61  
       cost of, 62  
       design of, 61f  
       extrusions of, 61  
       fabrication of, 60-64  
       installation of, 63  
       O-rings of, 61

project team of, 63f  
trace oxygen analyzer in, 62  
Newman, R., with Arney, 9  
Newton, J., with Smith, 17  
*Nicobium castaneum*, 18, 19f  
Nikolaev, G., with Petushkova, 23  
nitrogen  
for color fading, 9  
and light-sensitive colors, 7  
for linen storage, 8  
for metal storage, 8  
for paper storage, 8  
nitrogen anoxia, 17, 18, 20f, 26  
Noble, P., with Koestler, 9, 17  
NPL. See National Physical Laboratory

## O

organic dyes, fading of, 9  
organic materials, deterioration of, causes of, 1  
O-rings, 31, 33, 55f, 61  
ortophenyl phenol, 17  
oxygen  
and deterioration, 7-15  
and fungal/bacterial growth, 22f  
oxygen absorbers, 3  
oxygen scavengers, 35-37, 39f  
oxygen sensor, 34

## P

Pääbo, S., 17  
paper  
deterioration of, 9  
oxygen-free environment for, 7-8  
parchment  
deterioration of, case studies of, 9-11  
oxygen-free environment for, 7-8  
preservation of, 9  
Parliament Library, India, 53  
Parmar, S. S., 39  
Parreira, E., with Koestler, 9, 17  
Passaglia, E., 8, 31  
*Penidllium*, 24, 25f  
*Penidllium commune*, 20, 21f  
pentachlorophenol, 17  
Petushkova, P., 23  
pigments, fading of, 9  
pleated Teflon (PTFE) membrane filters, 40  
Plexiglas  
in argon treatment, 25f  
for metal storage, 8  
Poggrund, R. S., with Sobel, 9  
pollution sorbent, 39  
polyisobutylene, 31  
Poole, J. B., with Burton, 10  
Preservation Capsule, 8  
pressure-relief valve, 34

Preusser, R, 5  
with Lambert, 37  
with Maekawa, 26  
with Valentín, 1, 10, 18  
proteins, preservation of, 9  
PTFE. See pleated Teflon membrane filters

## R

Raizada, Shri P. B. N., 53  
Ramses II, mummy of, conservation treatment of, 1  
Ravenel, N., with Hanlon, 18  
red vermilion, fading of, 9  
Reed, R., with Burton, 10  
rehydration, of mummies, 11  
relative humidity (RH)  
and collagen, 12  
and fungal/bacterial growth, 21, 22f  
ideal level of, 3  
and parchment, 10-11  
relative humidity buffer, 37-39  
relative humidity sensor/transmitter, 34  
RH. See relative humidity  
Rogers, G., 5  
Royal Mummy Collection  
closing of, 1-2  
conservation of, 1-5  
display case for, 4f, 47-52, 50f  
construction of, 47-50  
cost of, 47  
design of, 3-5  
exploded view of, 48f  
extrusions of, 48  
fabrication of, 3-5  
modifications to, 48-49  
oxygen leak rate of, 4  
project development, 2-3  
proposed storage conditions, 3  
retention strips of, 48-49  
schematic drawing of, 49f  
size of, 49  
preservation of, 11  
Royal Mummy Room, 47f, 50f, 50-51  
mummies in, 52  
Russell and Abney Report of 1888, 7  
Rust, M., 1, 18

## S

*Saccharomyces rouxii*, 21  
el-Sadat, Anwar, 1-2  
Saint-Gobain Company, 54  
Salins, E., 8  
Santoro, E., with Koestler, 9, 17  
Schilling, M. R., 10  
SCTUB. See Serveis Científics Tècnics de la Universitat de Barcelona

- sericin, 9  
 Serveis Científics Tècnics de la Universitat de Barcelona (SCTUB), 60  
 Shroud of Turin, storage of, 8  
 sienna, fading of, 9  
 silica gel, 37  
 silicone sealant, in display case construction, 33  
 silk, 9  
 silver-soldering technology, 31  
 Smith, C, 17  
 Sobel, H., 9, 10  
   with Hansen, 9, 10, 23  
 sodium salt, 17  
 sodium salt p-chloro-m-cresol, 17  
 South Kensington Museum, 7  
*Stachybotrys*, 24, 25f  
 static system, 31  
*Stegobiumpaniceum*, 18, 19f  
 Stillings, R. A., 8  
*Streptococcus* sp., 21f, 24, 25f  
*Streptomyces* sp., 20, 21f, 24, 25f  
 sulfuryl fluoride, 17  
 Supreme Council of Antiquities, 1, 2, 5, 47, 61.  
   See also Egyptian Antiquities Organization
- T**  
 temperature, 3  
   effect on insect mortality, 18, 19f, 20f  
   and hermetic seals, 31  
 temperature sensor, 34  
 tetralkylammonium salts, 17  
 Thomson, G., 39  
 thymol, 17  
 Toishi, K., 31  
 toxic cresols, 17  
 trace oxygen analyzer, 62  
 Traub, W., with Weiner, 10
- Trullen, J. M., 59  
 tyrosine, in parchment, 10
- U**  
 Uesaka, T., with Zou, 8  
*Ulodadium*, 24, 25f  
 ultraviolet radiation, effect on cellulose, 8  
 University of Turin, 8  
 U-tube manometer, 34
- V**  
 vacuuming, 17  
 Valentín, N., 1, 3, 10, 17, 18, 19, 23, 59-60, 62  
 Van Nostrad, R. J., with Stillings, R. A., 8  
 vellum  
   and humidity, 10  
   preservation of, 9  
 Vikane, 17  
 Vilardell, R, 61
- W**  
 water-absorption curves, of mummies, 11  
 watercolors, fading of, 7, 9  
 Weaver, K. R, 8  
 Weiner, S., 10  
 Weintraub, S., 5, 39  
 Whatman filter paper, deterioration of, 8  
 Whitmore, P. M., 8  
 Wilson, A., with Pääbo, 17
- X**  
*Xestobium rufovillosum*, 19f
- Y**  
 yeasts, 21
- Z**  
 Zou, X., 8



## About the Authors

**Eric F. Hansen** is an associate scientist who joined the Getty Conservation Institute in 1985. He received his M.S. in organic chemistry from the University of California, Irvine, and is currently pursuing studies of architectural sculpture of the Ancient Maya at the University of California, Los Angeles, as a C. Phil. in archaeology. His research interests include the deterioration of natural materials, the factors affecting the treatment of painted objects, and the properties of polymers used in conservation. He was chair of the American Institute for Conservation of Historic and Artistic Works (AIC) subgroup on Research and Technical Studies in 1993 and became a fellow of the AIC in 1992.

**Nasry Yousef Iskander** received his B.S. degree in physics and mathematics from the University of Alexandria in 1965, and has expertise in practical machining and woodwork. He has been the general director of conservation of the Egyptian Antiquities Organization (now Supreme Council of Antiquities) since 1984, as well as chief of the Conservation Laboratories of that organization since 1980.

**Hari Kishan** received his M.S. degree in physics from Kurukshetra University, India, in 1971 and his Ph.D. in low-temperature semiconductor physics from Delhi University in 1986. In 1973, he joined the National Physical Laboratory (NPL) in New Delhi, where he has been participating in research and development work on low-temperature, solid-state physics and applied cryogenics. He is now a senior scientist at the NPL and a life member of several scientific professional societies. He received an award from the Indian Cryogenic Council in 1985 for his work in applied cryogenics and has published more than forty research papers in journals and conference publications. His research interest is in the field of cryogenics, preservation of national heritage objects, and humidity measurements. He is presently engaged in establishing a National Humidity Standard at the NPL.

**Shin Maekawa** received his M.S. degree in mechanical engineering from the University of California, Los Angeles, in 1978. Since 1990, he has been a senior scientist at the Getty Conservation Institute, where he has been conducting research on the microenvironment of display and storage cases as well as environmental monitoring at various archaeological sites.

**Nieves Valentín** received her Ph.D. in biological sciences from the Universidad Complutense, Madrid, and joined the Spanish Ministry of Culture in 1973. Since 1987, she has been a research scientist at the Instituto de Conservación y Restauración de Bienes Culturales (now Institute del Patrimonio Histórico Español) in Madrid. From 1987 to 1989, she was a research associate at the Getty Conservation Institute, where she developed projects on the biodeterioration of museum collections and the application of new deinfestation methods for the conservation of historic collections. Her research activity focuses on new technologies applied to the analysis of alterations to cultural materials. Since 1989, she has collaborated on investigations related to the biodeterioration of monumental stonework and historic stained glass.



ISBN 0-89236-529-3



9 780892 365296 90000