

DOE-BES SBIR Phase II Proposal

**Development of a CW Superconducting RF Booster
Cryomodule for Future Light Sources**

Terry Grimm, Andrew Bogle, Brian Deimling, Jerry Hollister,
Randall Jecks II, Ahren Kolka and Chandra Romel
Niowave, Inc.
1012 N. Walnut
Lansing MI 48906
www.niowaveinc.com

Collaborators (not funded by this proposal)
Derun Li
Accelerator and Fusion Research Division
Lawrence Berkeley National Laboratory
Berkeley CA 94720

SUMMARY

Future light sources based on seeded free electron lasers (FEL) have the potential to increase the soft x-ray flux by several orders of magnitude with short bunch lengths to probe electron structure and dynamics. A low emittance, high rep-rate radio frequency (RF) photocathode electron gun will generate the electron beam that will require very stringent beam control and manipulation through the superconducting linear accelerator to maintain the high brightness required for an x-ray FEL.

The initial or booster cavities of the superconducting radio frequency (SRF) linear accelerator will require stringent control of transverse kicks and higher order modes (HOM) during the beam manipulation and conditioning that is needed for emittance exchange and bunch compression. This SBIR proposal will develop, fabricate and test a continuous-wave SRF booster cryomodule specifically for this application.

Phase I demonstrated the technical feasibility of the project by completing the preliminary SRF cavity and cryomodule design and its integration into an R&D test stand for beam studies at Lawrence Berkeley National Laboratory (LBNL). The five-cell bulk niobium cavities operate at 750 MHz, and generate 10 MV each with strong HOM damping and special care to eliminate transverse kicks due to couplers. Due to continuous-wave operation at fairly modest beam currents and accelerating gradients the complexity of the two cavity cryomodule is greatly reduced compared to an ILC type system.

Phase II will finalize the design, and fabricate and test the booster cryomodule. The cryomodule consists of two five-cell cavities that will accelerate megahertz bunch trains with nano-coulomb charge. The accelerating gradient is a very modest 10 MV/m with peak surface fields of 20 MV/m and 42.6 mT. The cryogenic system operates at 2 K with a design dynamic load of 20 W and total required cryogenic capacity of 45 W. The average beam current of up to 1 mA corresponds to a beam power of 10 kW per 5-cell cavity and will require 20 kW of RF power for transmission, control and regulation. The RF power will be supplied by a commercial tetrode.

Cryogenic tests will be carried out at LBNL to make use of their test facilities, cryogenics and laser systems, and for future use with beam. Demonstration of this new type of booster cryomodule will open many new applications of SRF linear accelerators.

Table of Contents

- I) Significance, Background Information, and Technical Approach
 - A. Introduction
 - B. Identification and Significance of the Problem or Opportunity, and Technical Approach
 - C. Anticipated Public Benefits
 - D. Degree to which Phase I has Demonstrated Technical Feasibility

- II) The Phase II Project
 - A. Technical Objectives
 - B. Work Plan
 - i. Preliminary Design
 - ii. Final Design
 - iii. Fabrication and Test Plan
 - C. Schedule
 - D. Budget
 - E. References

- III) Appendices
 - A. Signed Letter of Commitment from Research Institutions
 - i. John Corlett from Lawrence Berkley National Laboratory
 - B. Phase II Funding Commitment
 - i. Signed letter of Phase II Funding Commitment (MI)
 - C. Phase III Follow-On Funding Commitment
 - D. Facilities/Equipment
 - E. Consultants and Subcontractors

I. Significance, Background Information, and Technical Approach

A. INTRODUCTION

Advances in superconducting linear accelerators, especially superconducting radio frequency (SRF), during the past 10 years have opened up new opportunities such as the recently completed Spallation Neutron Sources (SNS), the International Linear Collider (ILC), Rare Isotope Accelerator (RIA), free electron lasers (FEL), Compton backscattered x-ray sources and advanced light sources. Future light sources will likely use continuous-wave (CW) SRF cavities with requirements that are unique to their need. This SBIR submission by Niowave proposes to develop a CW SRF booster cryomodule that has applications for nearly all future light source injectors.

Niowave, Inc. is a high-tech research and manufacturing company that specializes in superconducting particle accelerators and their components [1]. The technical expertise at Niowave includes electron beam welding, forming and machining high purity niobium, chemical etching facilities, ultra pure high pressure water systems for cleaning, cryomodule fabrication, cleanroom assembly, ultrahigh vacuum technology, and cryogenic, radio frequency and microwave engineering. Dr. Terry Grimm, the founder of Niowave, was a senior scientist and key member of the National Superconducting Cyclotron Laboratory's (NSCL) leadership for 13 years. The company is located in Lansing, Michigan near Michigan State University (MSU) due to its close collaboration with the university's NSCL and Engineering Departments. MSU's NSCL is a recognized world leader in the development of superconducting particle accelerators [2].

B. IDENTIFICATION AND SIGNIFICANCE OF OPPORTUNITY AND TECHNICAL APPROACH

Researchers are using advanced light sources at the heart of today's cutting edge research on a wide range of experiments. They also see how the next-generation light sources will play an even more prominent role in future experiments, by allowing them to investigate the properties of materials, examine samples for trace elements, explore the structure of atoms and molecules, study chemical reactions and construct microscopic machines. In order to build these future light sources, research and development specifically for future light sources will need to be carried out under the guidance of DOE's Basic Energy Science (BES) division.

Lawrence Berkeley National Laboratory (LBNL) has proposed to build a seeded FEL light source, which will require the acceleration of high charge, high rep-rate, low emittance bunches [3,4]. LBNL identified SRF cavities as the technology of choice for the booster portion of the injector in this future light source. LBNL and Niowave plan to collaborate on the SRF aspects of the proposed research so that the light source community can benefit from the expertise available in industry.

Niowave will design the SRF booster cryomodule in consultation with LBNL's accelerator physicists. LBNL is developing the front-end of the linac based on a copper radio frequency

(RF) gun that accelerates the electron beam to 750 keV followed by the SRF multi-cell cavities that will accelerate the beam to 20 MeV [5]. The average beam current for the injector system is 1 mA with plans for high charge operation, 1 nC at 1 MHz, and high brightness operation, 100 pC at 1 MHz. In addition to accelerating the beam, the SRF booster cryomodule will be used for emittance exchange and control of the low-emittance beams, in order to maintain the high brightness beam and eliminate beam breakup. Figure 1 shows a conceptual layout of the front end, and the linac front-end requirements are given in Table 1

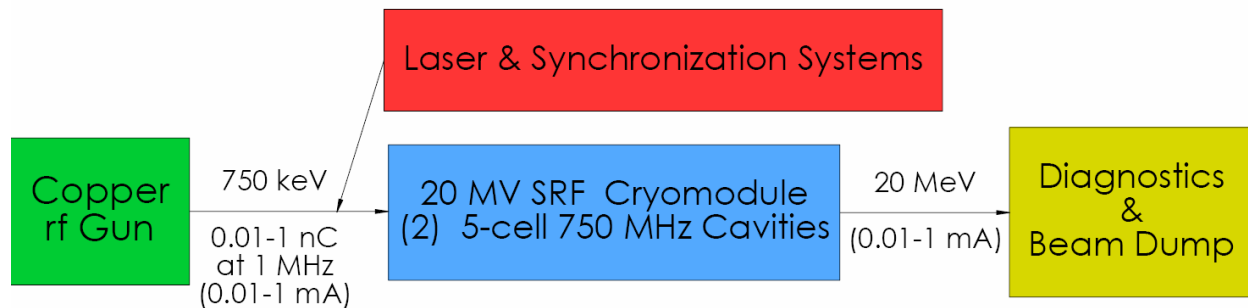

Figure 1. Conceptual layout of the LBNL linac front end.

Table 1. Requirements of LBNL linac front end.

Bunch Frequency (MHz)	1
Bunch Charge (nC)	0.01 – 1
Beam Current (mA)	0.01 – 1
Energy of RF Gun (MeV)	0.75
Extraction Energy (MeV)	20
Emittance	< 1 mm-mrad (slice averaged)
Energy Spread	~ 3 keV
Maximum Beampower (kW)	20

C. ANTICIPATED BENEFITS

The LBNL research and development program toward advanced FELs addresses the needs for a next generation of x-ray radiation sources with new capabilities in photon pulse characteristics, which will allow study of phenomena inaccessible to either third-generation synchrotrons or other existing light sources. The development of the booster module will help advance the design of advanced light sources which researchers can use for a wide range of experiments. Some uses of future light sources will be to investigate the properties of materials, examine samples for trace elements, explore the structure of atoms and molecules, study chemical reactions and construct microscopic machines.

The collaboration between a national laboratory and private sector on SRF aspects of the proposed research will benefit the light source community. The Federal Government will be able to rely on industry to commercialize and manufacture certain components, such as SRF

cryomodules, for future light sources. By involving industry in the production of proven concepts and processes the government will save time and money. Federal government laboratories can spend the saved effort and funds towards increased scientific research and discovery.

D. DEGREE TO WHICH PHASE I HAS DEMONSTRATED TECHNICAL FEASIBILITY

The technical feasibility of the SRF booster cryomodule has been clearly shown in the completed preliminary design study. The use of a TESLA/ILC like 5-cell structure ensures that the capabilities and technical feasibility of the SRF cavities is well documented. The successful implementation of higher order mode (HOM) damping in storage rings using the same techniques proposed here, demonstrates the technical feasibility of its implementation in this project.

In the next section the detailed design of the SRF booster cryomodule including all subsystems for testing and demonstrating the booster are presented. The Phase I work has shown a robust design with no foreseen barriers or show stoppers.

II. The Phase II Project

A. TECHNICAL OBJECTIVES

Future light sources based on seeded FEL have the potential to increase the soft x-ray flux by several orders of magnitude. The beam manipulation possible in a superconducting linac makes extremely short pulse lengths possible (sub-femtosecond) to probe electron structure and dynamics. A low emittance, high rep-rate RF photocathode electron gun will generate the electron beam. Very stringent beam control and manipulation will be required through the superconducting linear accelerator to maintain the high brightness required for an x-ray FEL.

The initial or booster cavities of the SRF linear accelerator must minimize perturbations due to transverse kicks and HOM during the beam manipulation and conditioning that is needed for emittance exchange and bunch compression. This SBIR research will develop a new type of booster cryomodule for linac based advanced light source injectors, using multi-cell SRF cavities. Phase I has shown the technical feasibility of the design and produced a preliminary design for the cavity and cryomodule. In Phase II the booster cavity and cryomodule design would be finalized and fabricated. The final stage of Phase II would be testing of the cryomodule at LBNL, including verification of HOM damping. Phase III would be funded by LBNL for their applications, and Niowave would provide the booster cryomodule commercially to a range of users.

B. WORK PLAN

i. Preliminary Design

The preliminary design for the cavity and its cryomodule were completed in Phase I and are presented here. The cryomodule consists of two SRF 5-cell cavities operating at 750 MHz. The cell shape is a scale model of the TESLA/ILC multi-cell design. The staff at Niowave have prototyped 1.3 GHz TESLA/ILC cavities for Fermi National Accelerator Laboratory. The two five-cell cavities are connected via a large beam pipe which is below cutoff for the 750 MHz fundamental mode so they do not couple and therefore operate independently. For HOM frequencies above the beam pipe cutoff the cavities will appear to be a single structure, with the couplers located on the beam pipe being used to damp the harmful HOMs.

Since the cavities operate CW, the frequency tuner will be mechanically coupled to room temperature so the stepper motors and optional piezoelectric actuators use inexpensive commercial components that are easy to maintain. Two mu-metal shields will be placed around the cavities to reduce stray magnetostatic fields to acceptable levels. Additional magnetic shielding comes from the low carbon steel vacuum vessel. The design magnetic field will be kept below 90 mT which is well below the critical field of 180 mT for niobium.

Electromagnetic Design of Booster Cyromodule

The RF frequency was chosen to be 750 MHz, which is a sub-harmonic of the 1.5 GHz FEL RF system frequency. The cavity design was modeled on a frequency scaled version of the 1.3 GHz ILC TESLA cavities shown in Figure 2 [6]. The cavity endcups were designed by Niowave to match the beampipe diameters of the booster. Endcup 1 has a smaller iris radius to help minimize impedance mismatches with the system beampipe, while Endcup 2 has a larger iris radius that helps with damping the harmful HOMs. The scaled mid and end cup dimensions desired for this booster module are given in Table 2.

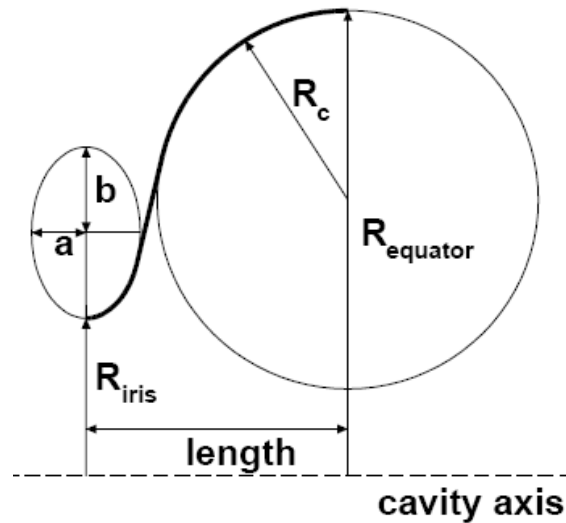

Figure 2. Conceptual layout of the LBNL linac front end.

Table 2: Scaled half cell shape parameters.

Dimension in (mm)	750 MHz - Desired		
	Midcup	Endcup 1	Endcup 2
Equator Radius	179.05	179.05	179.05
Iris Radius	60.67	25.00	75.00
Radius of Circular Arc	72.80	69.85	72.80
Horizontal Half Axis (a)	20.80	17.33	15.60
Vertical Half Axis (b)	32.93	23.40	22.19
Length (l)	100.01	97.07	98.80

The general cavity parameters are listed in Table 3. The maximum surface electric field is 20 MV/m which is very modest with today's capability for SRF cavities. The cavity has a fairly large transverse dimension with the largest equator diameter of 35.81 cm. The relatively large diameter reduces the peak surface magnetic field to 42.6 mT, which is very modest and should allow high Q operation with minimal Q-slope or additional surface resistance.

The active length of each cavity is 1 m, which gives an accelerating gradient of 10 MV/m. This cavity should be capable of reaching peak surface fields that are two to three times larger than the design value, which gives further confidence that the desired field levels can be reached.

Table 3: General cavity parameters: T is the operating temperature, and E_p and B_p are the peak surface electric and magnetic fields, respectively.

Type	5-cell TESLA/ILC
f (MHz)	750
V_a (MV)	10.0
L(m)	1.00
E_{acc} (MV/m)	10.0
E_p (MV/m)	20.0
E_{peak}/ E_{acc}	2.0
B_{peak}/ E_{acc} (mT/ (MV/m))	4.26
B_p (mT)	42.60
Aperture (m)	0.05
He Vessel Diameter (m)	0.42
Cavity Mass (Nb, kg)	59.0
Cavity Mass (Nb & Ti, kg)	130.0
T(K)	2.0

The electromagnetic and cryogenic parameters of the each 5-cell cavity are listed in Table 4. Each 5-cell cavity is designed to accelerate the electron beam a total of 10 MV. A residual surface resistance of 5 nOhm is assumed, along with the 5.5 nOhm BCS surface resistance to determine the maximum anticipated Q of this cavity during testing of 2.6×10^{10} . A safety factor of 2 is included for additional losses due to Q-slope, stray magnetostatic fields, surface contaminants, etc., to give a conservative design Q of 1.3×10^{10} . The corresponding design power of 13.4 W at 2 K is supplied to the cavity via the RF and is dissipated in the cryogenics.

Table 4: Electromagnetic and cryogenic parameters

Type	5-cell TESLA/ILC
f (MHz)	750
T(K)	2
R/Q(Ω)	575.5
G(Ω)	270
G·R/Q ($k\Omega^2$)	155.4
V_a (MV)	10.0
U (J)	36.9
$R_{BCS,min}$ (n Ω)	5.5
$R_{res,min}$ (n Ω)	5
Q_{max}	2.6×10^{10}
$Q_{design}=Q_0$	1.3×10^{10}
$P_{design}(W/cav)=P_0$	13.4

Higher Order Modes

The broadband impedance of the linac and RF cavities, as well as the shunt impedance of the HOMs in the cavities must be limited in order to maintain the high brightness beam and eliminate beam breakup. The first consideration is to use a large diameter beam pipe. This will do two things: first, it will act as a filter to reduce the fundamental mode since it is below cutoff; second, if the diameter is made large enough that all HOMs are above cutoff then the two multi-cell cavities will act as one. This should be a benefit in terms of the number of HOM couplers that are needed. The diameter also influences the R/Q of HOMs and could be tuned to minimize R/Q of the most dangerous modes. By maintaining a large beam pipe between the two cavities, the adjacent cavity's fundamental coupler can couple to orthogonal dipole HOMs that are above cutoff and are not adequately damped by the other antennas. The beam pipe length must accommodate all of the couplers, but it can be adjusted to minimize the R/Q of the most dangerous HOMs.

Mechanical Design of Booster Cryomodule

The mechanical design is shown in Figures 3-5. The large cavity will require niobium that is 4 mm thick with a per cavity niobium weight of 59 kg. A high RRR material (around 300) is proposed for this project, however, the use of a lower RRR (around 100) would drastically cut costs with minimal effect on performance and will be considered during the final design. The helium vessel is made of titanium and is attached via niobium-titanium transitions. A long titanium cylinder above the cavities will serve the dual purpose of helium reservoir and alignment rail. The helium transfer port will transition to 304 stainless steel in the cryomodule through a port out of the top of the reservoir.

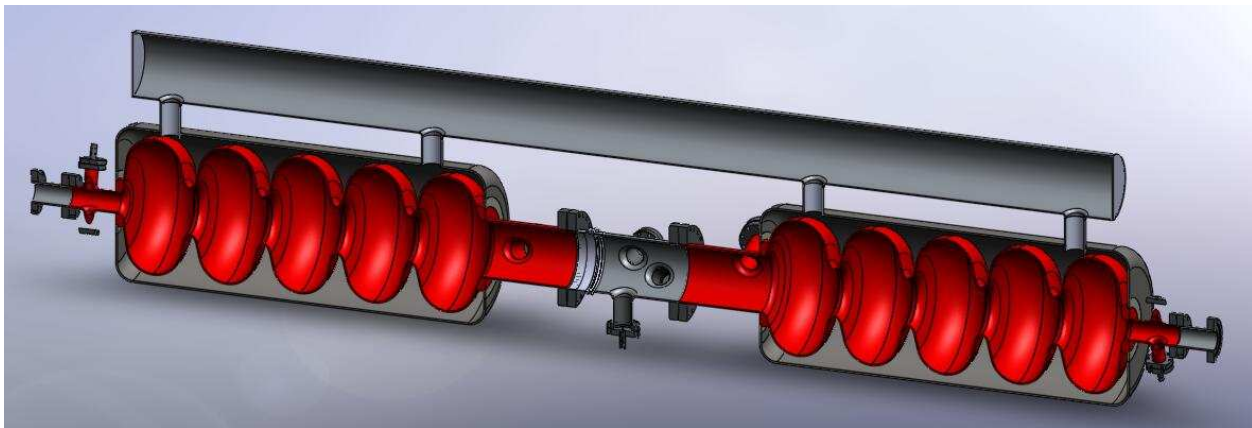

Figure 3. 750 MHz booster cavity.

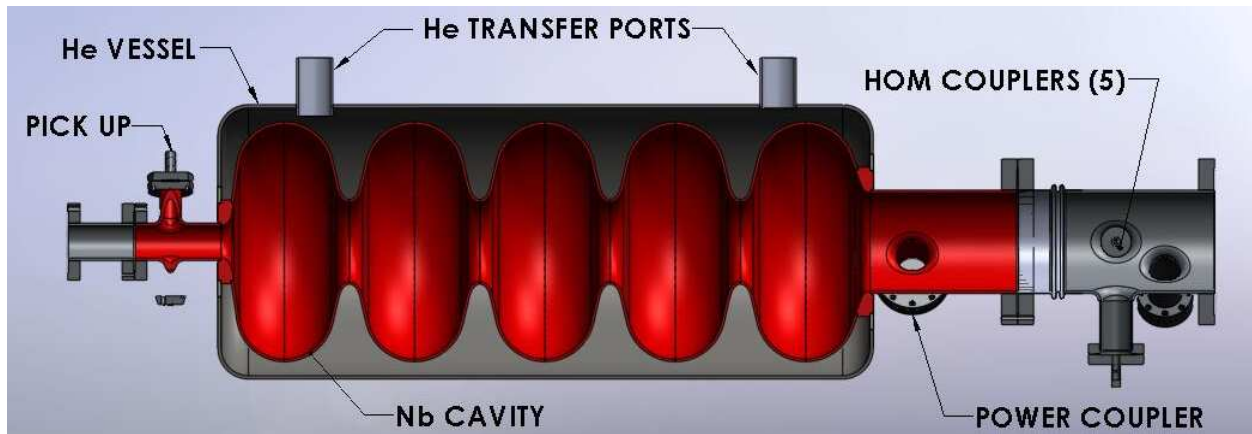

Figure 4. 750 MHz booster cavity.

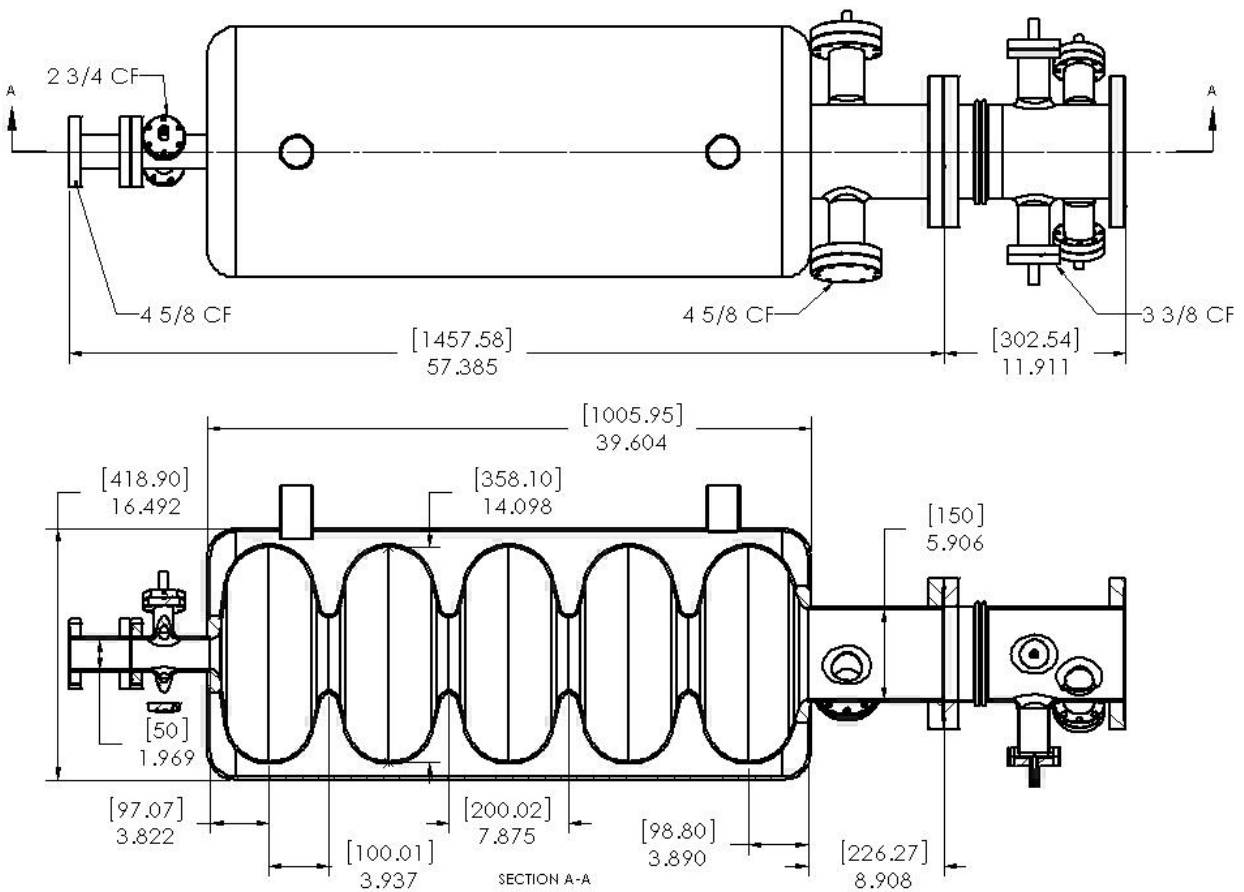

Figure 5. 750 MHz booster cavity dimensions.

Beam current and RF requirements

The maximum beam current envisioned for the booster cryomodule is 1 mA, which consists of 1 nC bunches at 1 MHz. To accelerate this average current to 10 MeV requires 10 kW of RF power at 750 MHz. To account for transmission losses, and amplitude and phase regulation, the power amplifier must supply 20 kW. The loaded Q would be 8.7×10^6 so microphonics and other detuning issues should be negligible. Table 5 summarizes the beam loading requirements.

Table 5: Beam loading requirements

Type	5-cell TESLA/ILC
V_a (MV)	10.0
f_{bunch} (MHz)	1.0
q_{bunch} (nC)	1.0
I_{beam} (mA)	1.0
P_{beam} (kW)	10
Q_{beam}	1.7×10^7
P_g (kW)	20.0
Q_L	8.7×10^6

At this low frequency, commercial tetrode based amplifiers are available from several vendors. The transmission line for the high power RF would use rigid coaxial lines and couple capacitively in the high electric field region of the cavity. Table 6 gives the RF requirements.

Table 6: RF requirements per cavity.

Cavity	5-cell TESLA/ILC
Frequency (MHz)	750
Quantity	2
P_g (kW)	20
Amplifier Type	Tetrode vacuum tube

Cryogenic requirements

The requirements for the cryoplant are based on conservative assumptions. The dynamic load is 20 W for both cavities, which has a safety factor of two to guarantee the ability to operate the gun even if the Q is degraded due to contaminants, Q-disease or other possible loss mechanism. The static load is caused by thermal radiation and conduction through the support links, couplers, the cathode assembly and the beam port. A static load of 10 W which is roughly equal to the dynamic load can easily be met and does not make the support system overly complex or fragile. The overhead covers the load due to the bayonets, transfer line, valves and vacuum breaks, and is assumed to be 50 % of the static and dynamic cryomodule load. The total load is 45 W at 2 K and is summarized in Table 7.

A liquid nitrogen thermal shield at 77 K reduces the thermal radiation and is used to intercept heat from room temperature components. Alternatively, the thermal shield could be cooled with helium gas at 35-50 K if it is available at LBNL. The thermal shield load will be less than 100 W, which is significantly less cooling requirements due to Carnot efficiency.

Table 7: Cryogenic requirements

T(K)	2 K
Dynamic Load (W)	20
Static Load (W)	10
Overhead (W)	15
TOTAL LOAD (W)	45

Cryomodule design

The cryomodule will house both of the 750 MHz booster cavities as shown in Figure 6. The cavity will be cooled to 2 K and shielded from the earth's magnetic field to eliminate RF losses caused by trapped flux during cool down. An important aspect of this design is that the beamline vacuum will be isolated from the insulating vacuum to improve the cleanliness of the beam vacuum and improve the thermal isolation of the cavity with super-insulation.

The coldmass is processed in the Class 100 cleanroom at Niowave and hermetically sealed so it can be transported to a nearby assembly area. The coldmass is shown in Figure 7 and consists of the cavity with titanium helium vessel, power and pick-up couplers, and beamline transition regions to room temperature with gate valve and beamline vacuum system.

Pressure vessel code

The cryomodule and helium vessel design will be reviewed by LBNL staff. Since the cryomodule will be tested at LBNL, special attention will be given to compliance with pressure vessel code by consulting with local experts at LBNL. Compliance with the pressure vessel code at DOE laboratories can involve a lengthy approval process, so this step will be done early in the Phase II work.

Power and pick-up coupler

For the low frequency and beam loading of about 1 mA, a coaxial transmission line with ceramic vacuum break will be used. The ceramic window is based on the window used for the 805 MHz Spallation Neutron Source superconducting cavities. The outer conductor is copper plated stainless with a liquid nitrogen intercept to reduce the thermal load to the cavity to about 1 W. The pickup uses a type-N vacuum feed through and a flexible coaxial cable with liquid nitrogen thermal intercept. The power coupler and field probe will also be used to damp HOMs. By maintaining a large beam pipe between the two cavities, the adjacent cavity's power coupler can couple to orthogonal dipole HOMs that are above cutoff and are not adequately damped by the cavity antennas.

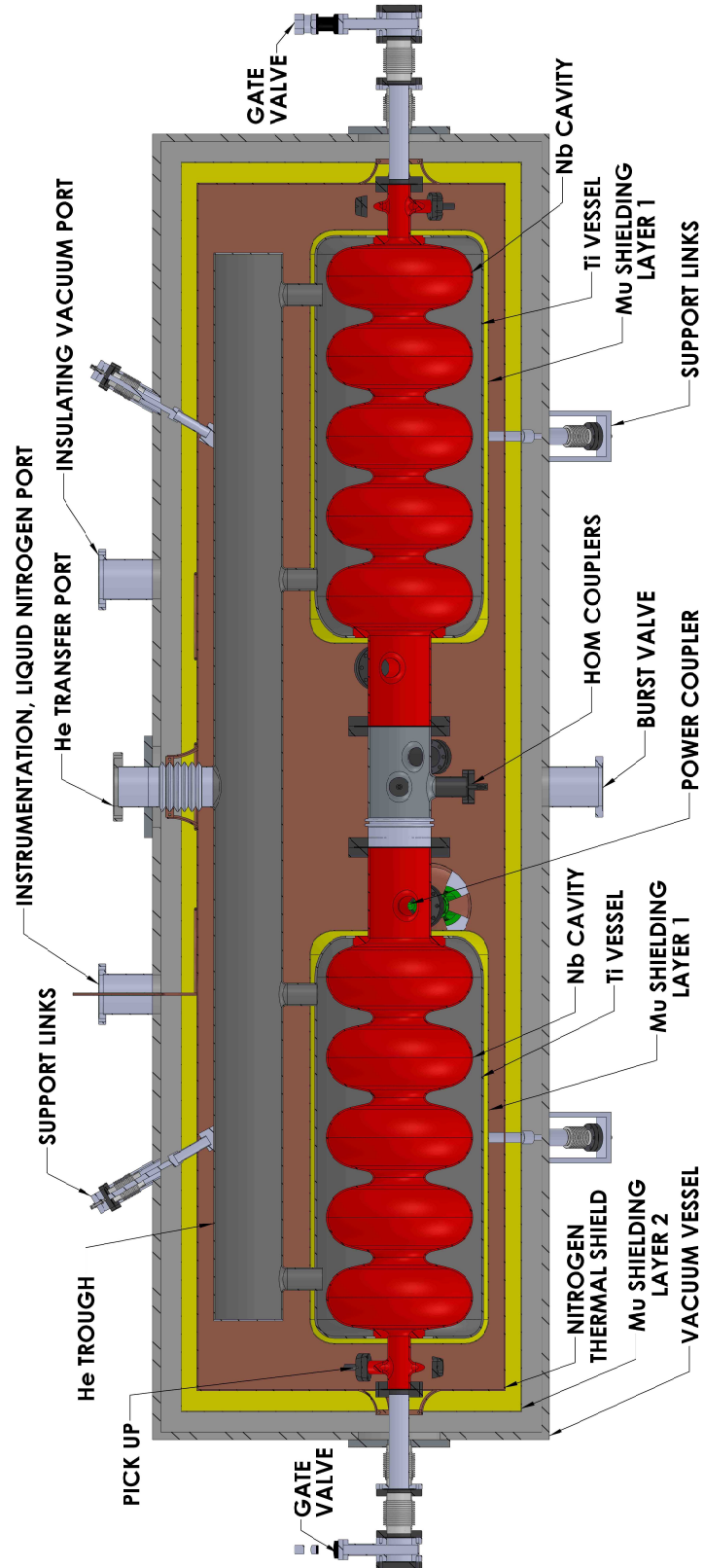

Figure 6. Cryomodule design for the 750 MHz SRF booster cryomodule.

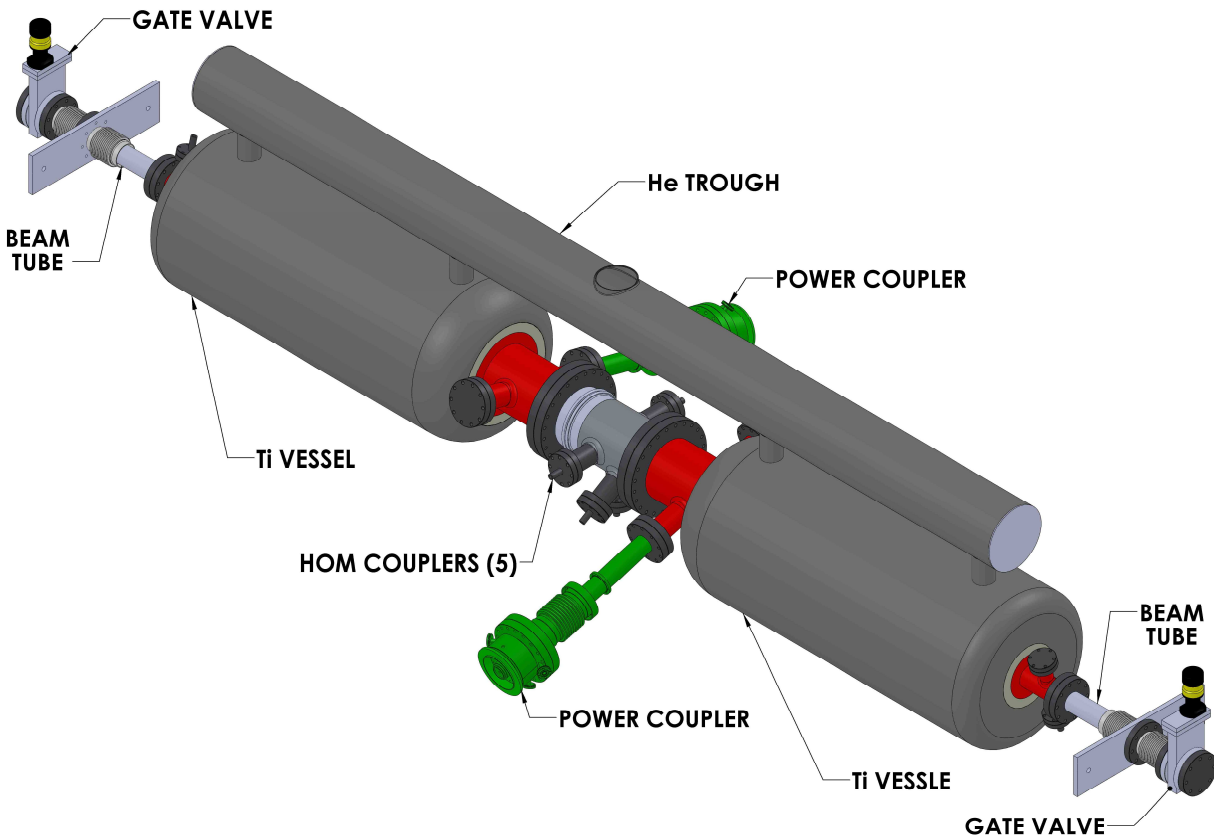

Figure 7. Coldmass/cleanroom assembly for the 750 MHz SRF booster cryomodule.

HOM couplers and loads

The conceptual design shows one fundamental pickup coupler and two HOM couplers per cavity. If all HOMs see the couplers of both cavities then perhaps less could be adequate. The pickup can also be used to damp HOMs, and since they are at different azimuthal positions, they can damp transverse modes also. The locations and coupling strength of the HOM couplers will be finalized in Phase II.

Vibration/microphonics control

Low level RF control of the amplitude and phase require that the cavity resonant frequency remain within the bandwidth. With the relatively low loaded Q and large diameter, the detuning caused by vibrations should not be an issue. Nearby sources of vibration or microphonics can be damped or isolated from the cavity. The cavity is already isolated from the cryomodule vacuum vessel by support links. Also, the frequency tuner can compensate for vibrations by canceling the frequency shift, which is much simpler than damping vibrations.

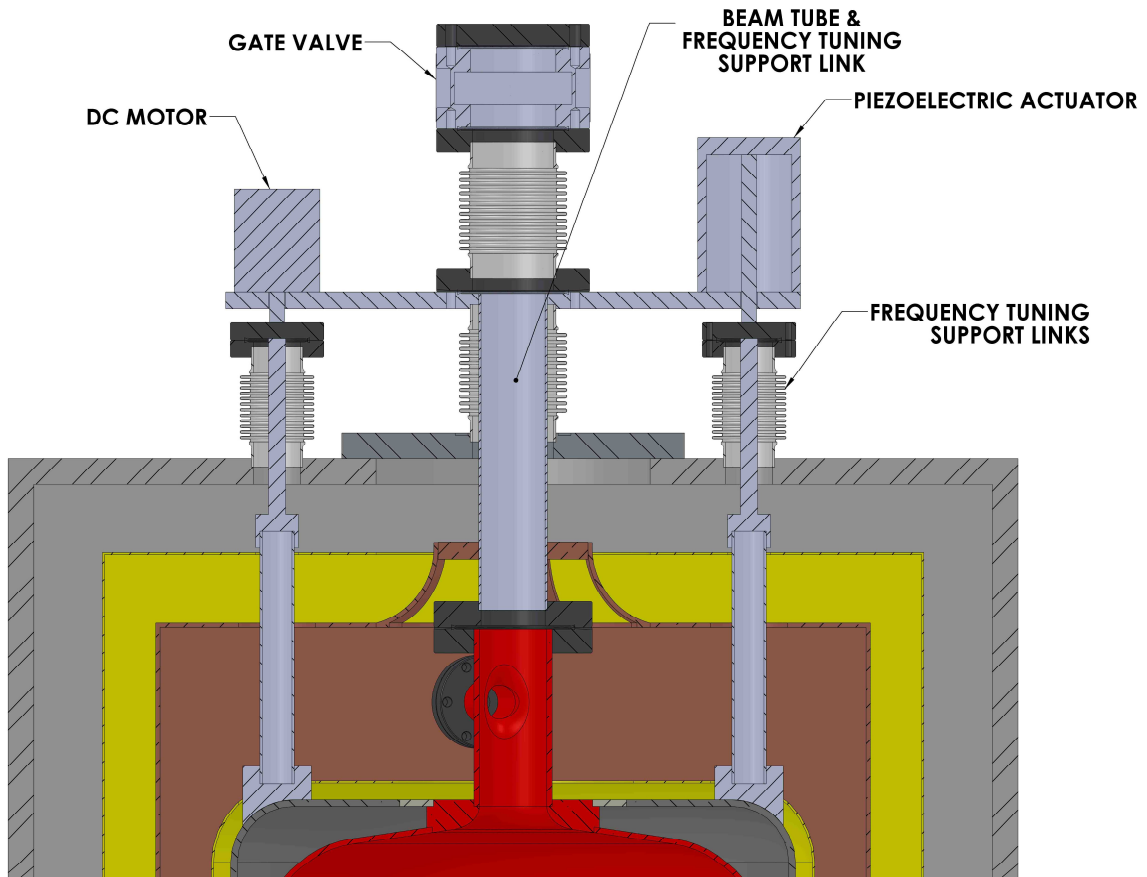

Figure 8. Tuner assembly design for the 750 MHz SRF booster cryomodule.

Frequency tuner

The cavity operates in CW mode so Lorentz detuning does not interfere with cavity performance. The tuner uses mechanical linkages to room temperature so the motor (slow tuner) and piezoelectric actuator (fast tuner) can be mounted in air at room temperature. This simplifies maintenance and future modifications. Figure 8 shows the tuner assembly.

Thermal shield

A copper shield is used to intercept thermal radiation and is cooled via copper tubes with liquid nitrogen (77 K) or helium gas (35-50 K) if available from the cryoplant. The shield is also used to intercept heat on any mechanical connections such as couplers, beam lines and support links.

Magnetic shield

Two layers of mu-metal shield will be used to ensure the earth and other stray magnetic fields are reduced to appropriate levels. The first layer of mu-metal shield is directly around the two 5-cell cavities, with the second layer just outside the Nitrogen thermal shield. The low carbon steel vacuum vessel is the final help in reducing the field to less than one hundredth of the earth's field or 5 mG.

ii. Final Design Plan

The first 8 months of Phase II will be focused on finalizing the design and generating the production drawings. Additional mechanical analysis is required to determine material thicknesses and the need for gussets. Also, thermal analysis is needed to quantify the load and required thickness of stainless and copper plating. This work will be done primarily at Niowave.

LBNL will be consulted throughout the design process to assure that the requirements for their linac based FEL are met as well as their subsystems are compatible with the cryomodule. Once the cryomodule design is finalized, a formal design review will be scheduled that includes LBNL and other outside experts. Compliance with pressure vessel code at DOE is ongoing with completion planned at the design review. Once the recommendations from the design review have been implemented, fabrication of the cryomodule will commence.

iii. Fabrication & Test Plan

Niowave has all of the required resources needed to finalize the design, and fabricate and test the cryomodule, except for the electron beam welding of the niobium. The facilities and equipment section of the proposal outlines Niowave's capabilities from the CNC machine shop and deep drawing presses to TIG welding, chemical processing, cleanroom assembly and cryogenic testing. The electron beam welding will be performed with one of the vendors available nearby that Niowave works with on a regular basis. Niowave has fabricated niobium structures and cryomodule assemblies of similar complexity for a broad range of applications.

The detailed schedule, milestones and budget are presented later in the proposal. The long lead item for this project is the multi-cell cavities due to the procurement time for the niobium and multiple cycles of electron beam welding. The order for the niobium will be placed as soon as the design is finalized. In parallel with delivery of the niobium, the forming dies, helium vessel and other subsystems will be fabricated. The cryomodule components can also be fabricated in parallel with the booster cryomodule. The frequency of the booster is fine tuned by adjusting the active length before the final weld.

Once the cavity is completed it will be chemically etched and high pressure rinsed in the Class 100 cleanroom. A vertical test is planned at Niowave, but this step can be bypassed due to time and budget constraints. The cavity will be hermetically sealed in the cleanroom with the power coupler, pick-up probe and beamline vacuum components. This cleanroom assembly, also called a coldmass since the entire assembly will be cooled to 2 K, is then removed from the cleanroom for installation into the cryomodule.

Cryomodule assembly is fairly straightforward since the components of the box are installed in pieces around the cavity. First, a mu-metal shield around the cavities, then super insulation is installed, then the copper thermal shield and intercepts, then more super insulation, then another mu-metal shield, followed by final super insulation. This assembly is done with the cavity hanging by metal rods in place of the upper support links.

The vacuum vessel is made from low carbon steel plate and welded vacuum tight. This is the same material used for the TESLA/ILC cryomodules. The material is demagnetized and acts as a magnetic and radiation shield.

Once the cryomodule is complete it is vacuum leak checked and cold shocked with liquid nitrogen. Next the insulating vacuum is vented and high strength shipping links are installed in place of the G10 thermal/support links. At this point the cryomodule can be shipped via truck to LBNL (air-shocks for delicate items).

In parallel with fabrication of the cryomodule, LBNL and Niowave will prepare the test area and subsystems at LBNL as shown in Figure 9. The other components for the injector assembly, shown in Figure 10, have completion dates very near the delivery date for the booster cryomodule. After individual tests on the SRF booster cryomodule are completed, the entire injector assembly will then be constructed and tested. Details on the integration of the cryomodule into the LBNL test stand will be presented at the final design review. The option to test the cryomodule at Niowave is available, but the strong support, facilities and interest at LBNL improves the prospects to successfully complete the project due to their input and expertise. LBNL's interest and commitment to perform this work at LBNL is reiterated in John Corlett's letter of support.

The Phase II test program will be done during the last 6 months of the project, and will demonstrate the cavity gradient and measure the dynamic and static cryogenic losses. A check for any microphonics or Lorentz detuning issues will also be run. The final tests of phase II will be to measure and analyze the HOMs and ensure that they are being damped appropriately.

Phase III will integrate the entire injector assembly into the overall system for the high repetition rate VUV-soft X-ray FEL. Niowave will also be positioned to offer the booster cryomodule commercially to other groups around the world.

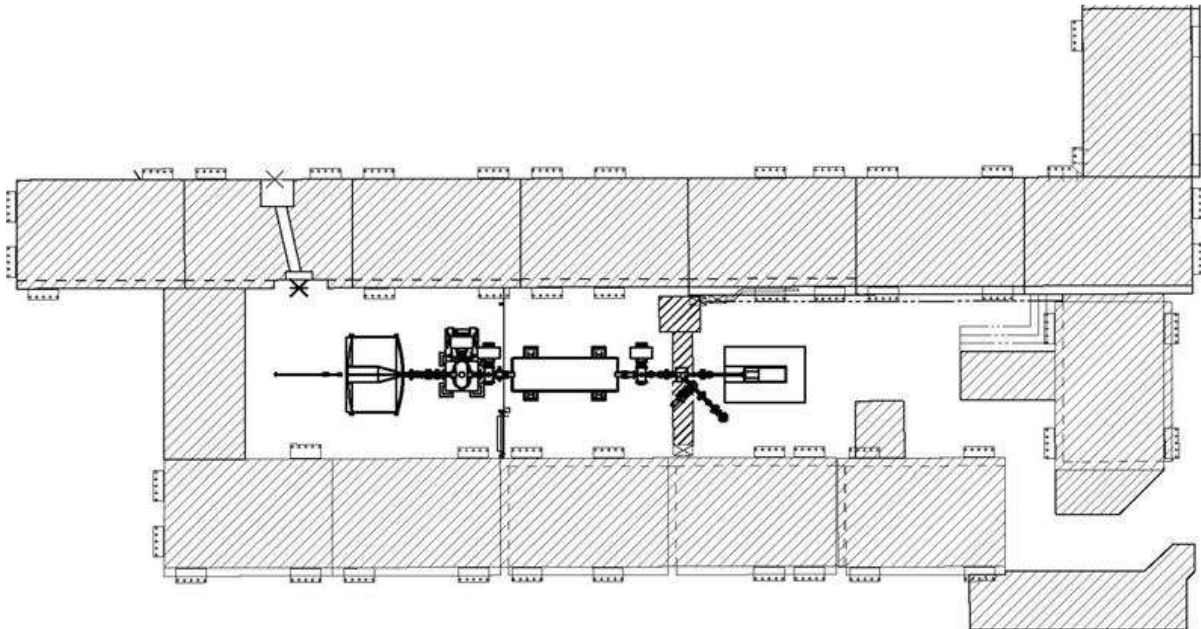

Figure 9. 750 MHz SRF booster cryomodule shown in beam test facility.

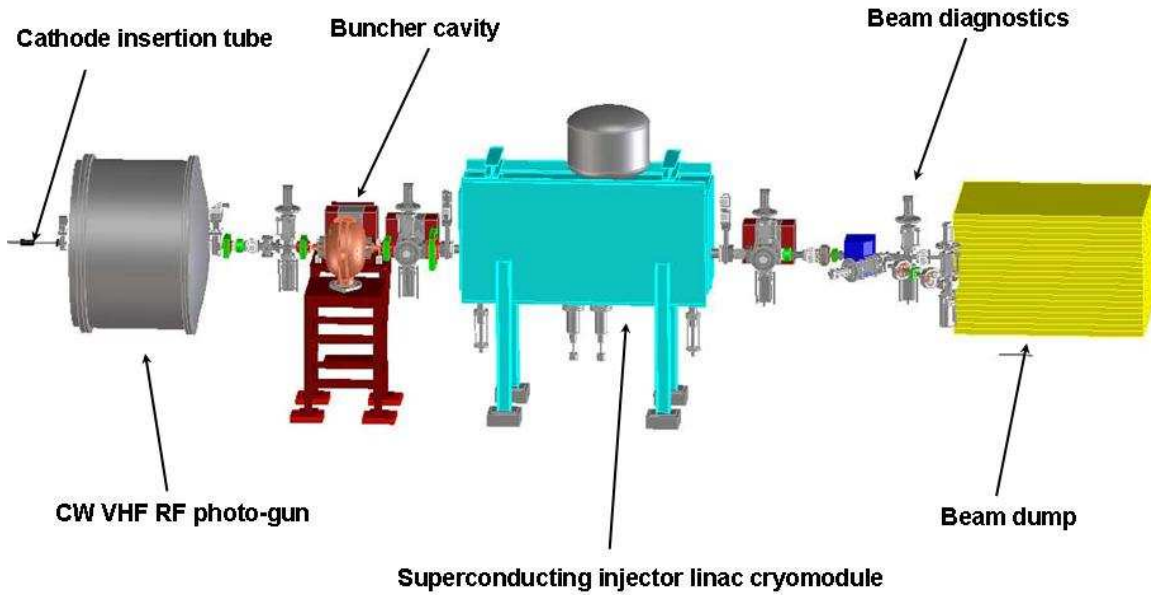
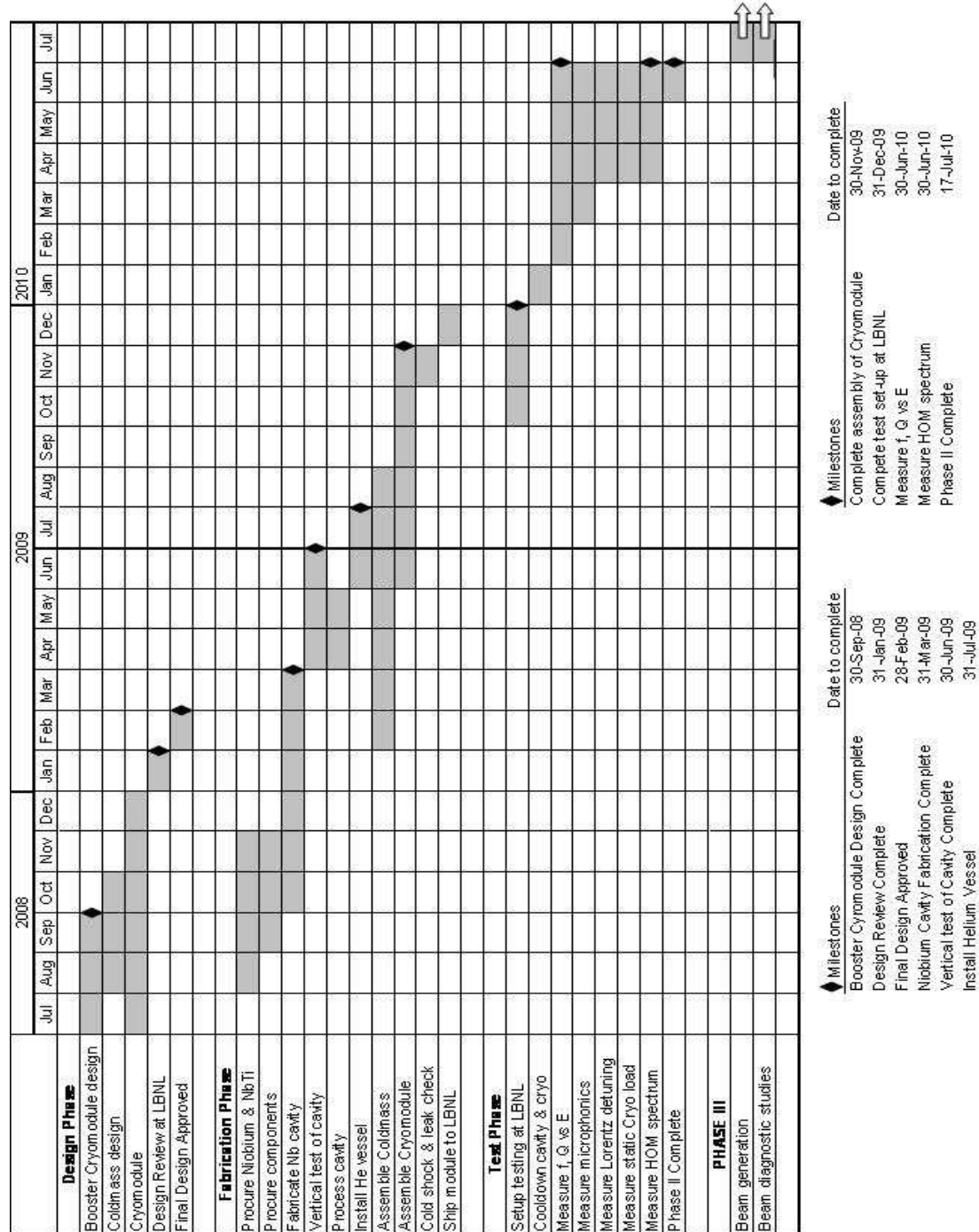

Figure 10. 750 MHz SRF booster cryomodule shown with rest of injector components.

C. Schedule

The timescale for this phase II SBIR will deliver an operational cryomodule ready for integration into the front end of the linac at LBNL in 2010, which matches well with the facility and RF gun project schedule.



D. Budget

The \$750k budget covers a 2 year time period. Table 7 shows a breakdown of the expenses per year for manpower, equipment and materials. All of the design and fabrication expenses will be incurred by Niowave except for the electron beam welding which will be done by a local vendor qualified in niobium welding.

Testing of the cryomodule will be done at LBNL. Expenses incurred by Niowave will be covered under this grant. Expenses for LBNL will be covered by external funding that will come from LBNL and/or matching funds that Niowave has qualified for from the State of Michigan. The appendix shows the letter of support from the State of Michigan to match external funds up to \$125k.

Table 7. SBIR phase II budget for the Booster Cryomodule.

	Year 1		Year 2		Two-Year Total	
	Manpower	Equip/Matl	Manpower	Equip/Matl	Manpower	Equip/Matl
Design Phase	\$89,848.85	\$0.00	\$0.00	\$0.00	\$89,848.85	\$0.00
Fabrication Phase	\$100,380.25	\$88,050.00	\$132,836.56	\$40,876.00	\$233,216.81	\$128,926.00
Testing Phase	\$0.00	\$0.00	\$79,563.23	\$25,000.00	\$79,563.23	\$25,000.00
Sub-Total	\$190,229.10	\$88,050.00	\$212,399.79	\$65,876.00	\$402,628.89	\$153,926.00
G & A (34.7%)	\$66,009.50	\$30,553.35	\$73,702.73	\$22,858.97	\$139,712.23	\$53,412.32
Fee		\$158.05		\$162.51		\$320.56
TOTAL	\$256,238.60	\$118,761.40	\$286,102.52	\$88,897.48	\$542,341.12	\$207,658.88
YEARLY TOTAL		\$375,000.00		\$375,000.00		\$750,000.00

E. References

1. Niowave website: www.niowaveinc.com
2. National Superconducting Cyclotron Laboratory website: www.nsl.msue.edu
3. J. Corlett, J. Byrd, W. M. Fawley, M. Gullans, D. Li, H. Padmore, G. Penn, I. Pogorelov, J. Qiang, D. Robin, F. Sannibale, J. W. Staples, C. Steier, M. Venturini, S. Virostek, W. Wan, R. Wells, R. Wilcox, J. Wurtele, A. Zholents, "A High Repetition Rate VUV-Soft X-Ray FEL Concept", Proceedings of PAC07, Albuquerque NM (07).
4. A. Belkacem, J. Byrd, J. Corlett, et al., "Design Studies for a High-Repetition-Rate FEL Facility at LBNL", Technical Reports, Synchrotron Radiation News, Vol. 20, No. 6, 2007.
5. J. W. Staples, K. M. Baptiste, J. N. Corlett, S. Kwiatkowski, S. M. Lidia, J. Qiang, F. Sannibale, K. G. Sonnad, S. P. Virostek, R. P. Wells, "Design of a VHF-Band RF Photoinjector with MHz Beam Repetition Rate", Proceedings of PAC07, Albuquerque NM (07).
6. B. Aune, et al., "Superconducting TESLA Cavities", Physical Review Special Topics – A&B, Vol. 3., 2000.

III. Appendices

- a. Signed Letter of Commitment from Research Institutions**
 - i. John Corlett from Lawrence Berkley National Laboratory
- b. Phase II Funding Commitment**
 - i. Signed letter of Phase II Funding Commitment (MI)
- c. Phase III Follow-On Funding Commitment**
- d. Facilities/Equipment**
- e. Consultants and Subcontractors**

A. Signed letter of commitment from research institution

Ernest Orlando Lawrence
Berkeley National Laboratory



ACCELERATOR AND FUSION RESEARCH DIVISION

Terry L. Grimm, PhD
President & Senior Scientist
Niowave, Inc.
1012 N. Walnut St.
Lansing MI 48906-5061

April 1, 2008

Dear Dr. Grimm,

Re: Development of a CW Superconducting RF Booster Cryomodule for Future Light Sources
Phase-II SBIR proposal

I write to confirm the support of the Center for Beam Physics in the work you are planning for this Phase-II SBIR. We look forward to collaborating in this important work for development of a CW superconducting RF cryomodule for future light source applications. We intend to take delivery of the cryomodule described in your proposal, and to integrate this with other injector components planned for an R&D program at LBNL. This test facility will allow measurements of beam quality, and component performance and reliability, from a high-brightness, high repetition-rate electron source. A CW accelerating system is a critical component of future light sources, and your proposal fits well with the needs to develop this technology.

With best regards,

John Corlett
Program Head
Center for Beam Physics
Accelerator and Fusion Research Division
Lawrence Berkeley National Laboratory

CENTER FOR BEAM PHYSICS
Accelerator and Fusion Research Division
1 Cyclotron Road
Berkeley, California 94720

Mailstop 71-259
phone: (510) 486-5228
fax: (510) 486-7981
e-mail: jncorlett@lbl.gov

Phase II funding commitment**Regional Centers**

Escanaba

Traverse City

Alpena

Harrison/Mt. Pleasant

Saginaw

Flint

Grand Rapids

Lansing

Detroit

Mt. Clemens

Kalamazoo

Ypsilanti

State Headquarters
Seidman College of Business
510 West Fulton Street
Grand Rapids, MI 49504
Phone: 616.331.7480
Fax: 616.331.7485
www.misbtdc.org

March 3, 2008

Jerry Hollister
Niowave, Inc.
1012 N Walnut
Lansing, Michigan 48906

Dear Jerry:

The Michigan Small Business and Technology Development Center (MI-SBTDC) is dedicated to fostering the growth of high technology companies and jobs that are focused on Michigan's competitive edge technology sectors. We recognize that the unique challenges inherent in technology innovation processes require support in many forms, including matching funds for federal SBIR/STTR programs. To that end, the MI-SBTDC has partnered with the Michigan Economic Development Corporation (MEDC) to administer \$1.4 million in federal grant matching through an Emerging Technologies Fund (ETF).

ETF eligible applicants must be involved in competitive edge technologies that are directly related to the fields of life sciences, homeland security/defense, alternative energy, or advanced automotive, manufacturing, and materials technologies. Under the new program, Niowave, Inc. would be eligible to receive a grant to match federal funding. If Niowave, Inc. is successful with its SBIR Phase II application with the Department of Energy, the state of Michigan intends to contribute a matching grant of 25% of federally awarded funds up to \$125,000 contingent upon the receipt of the SBIR Phase II award, commitment of third party matching funds, and the availability of funds.

Niowave, Inc. is an innovative company contributing to the diversification of Michigan's economy and creating new jobs. The continuous wave SRF booster cryomodule will be an important enabling technology involved in the production of alternative energy and is valued by the State of Michigan.

The MI-SBTDC looks forward to your successful application for SBIR Phase II funding and working with Niowave, Inc. in the future. If we can be of additional assistance in growing your company, please do not hesitate to contact Sara Gumina, ETF Intake Assistant at 734-347-0204 or by e-mail at mietf@gvsu.edu.

Sincerely,

Carol Lopucki, State Director
Michigan Small Business and Technology Development Center



Counseling • Training • Research

C. Phase III Follow-On Funding Commitment

Phase III would be funded by Niowave to offer the booster cryomodule commercially to a range of users. Once an SRF booster cryomodule has been demonstrated, there will be many applications ready to use this new technology. Also, use of this booster cryomodule in the VUV-soft X-ray FEL will fund its integration into that system.

D. Facilities/Equipment

The Phase II will be accomplished utilizing the facilities and equipment at Niowave, Inc. Facilities include:

- Design and engineering departments
- Machine shop and prototype lab
- Chemistry and cleanroom labs
- Cryogenic and microwave testing facilities

Niowave employs a variety of designers and engineers specializing in electrical, mechanical, and chemical disciplines. SolidWorks and AutoCAD software is used for design and structural analysis; Superfish and Analyst are used to simulate electromagnetic models for microwave structures.

Niowave houses a fully equipped machine shop and fabrication lab. Machine equipment includes CNC mills, CNC lathes, Bridgeport mills, manual lathes, 100 and 200 ton presses, rolling machines, cutting saws, and a CMM precision measuring device. Niowave also houses MIG/TIG welders used for leak tight stainless steel welds and anticipates housing an electron-beam welder within a year.

Niobium, niobium-titanium, and copper chemical and BCP etching is performed at Niowave for cavity processing. Niowave also houses a class 100 cleanroom; this facility contains ultra pure water rated at 18 MΩ·cm used for high pressure rinsing, the final processing step in preparation for cryogenic testing.

A cryogenic helium Dewar was constructed at Niowave to test cavities and cryomodules below 4.2 K at high energy fields. Niowave specializes in designing and building ultra high vacuum pumping systems and building circuits for high energy field studies. Niowave owns a wide range of electronic equipment including network analyzers and amplifiers used for cavity testing and analysis.

Aside from cavity processing and testing, Niowave also specializes in material science disciplines. RRR measurements are performed to qualify US vendors for high-purity niobium. Niowave also practices material forming for flanges, cavity components, and ultra high vacuum components.

E. Consultants and Subcontractors

Niowave will subcontract the electron beam welding of the niobium components. Niowave works with Sciaky, Inc. of Chicago and Roark, Inc. of Indianapolis, both of which are qualified niobium welders that we have worked with extensively in the past.. No consultants will be used.