



PNNL-18333

Prepared for the U.S. Department of Energy
under Contract DE-AC05-76RL01830

Caustic Recycle from Hanford Tank Waste Using Large Area NaSICON Structures (LANS)

MS Fountain
GJ Sevigny

S Balagopal
S Bhavaraju

March 2009



DISCLAIMER

This report was prepared as an account of work sponsored by an agency of the United States Government. Neither the United States Government nor any agency thereof, nor Battelle Memorial Institute, nor any of their employees, makes **any warranty, express or implied, or assumes any legal liability or responsibility for the accuracy, completeness, or usefulness of any information, apparatus, product, or process disclosed, or represents that its use would not infringe privately owned rights.** Reference herein to any specific commercial product, process, or service by trade name, trademark, manufacturer, or otherwise does not necessarily constitute or imply its endorsement, recommendation, or favoring by the United States Government or any agency thereof, or Battelle Memorial Institute. The views and opinions of authors expressed herein do not necessarily state or reflect those of the United States Government or any agency thereof.

PACIFIC NORTHWEST NATIONAL LABORATORY

operated by
BATTELLE

for the

UNITED STATES DEPARTMENT OF ENERGY
under Contract DE-ACO5-76RL01830

Printed in the United States of America

Available to DOE and DOE contractors from the
Office of Scientific and Technical Information,
P.O. Box 62, Oak Ridge, TN 37831-0062;
ph: (865) 576-8401
fax: (865) 576 5728
email: reports@adonis.osti.gov

Available to the public from the National Technical Information Service,
U.S. Department of Commerce, 5285 Port Royal Rd., Springfield, VA 22161
ph: (800) 553-6847
fax: (703) 605-6900
email: orders@nits.fedworld.gov
online ordering: <http://www.ntis.gov/ordering.htm>

Caustic Recycle from Hanford Tank Waste Using Large Area NaSICON Structures (LANS)

MS Fountain
GJ Sevigny

S Balagopal^(a)
S Bhavaraju^(a)

March 2009

Prepared for
the U.S. Department of Energy
under Contract DE-AC05-76RL01830

Pacific Northwest National Laboratory
Richland, Washington 99352

(a) Ceramatec Inc., Salt Lake City, Utah

Summary

This report presents the results of a 5-day test of an electrochemical bench-scale apparatus using a proprietary (NAS-GY) material formulation of a **(Na) Super Ion Conductor** (NaSICON) membrane in a Large Area NaSICON Structures (LANS) configuration. The primary objectives of this work were to assess system performance, membrane seal integrity, and material degradation while removing Na from Group 5 and 6 tank waste from the Hanford Site. Results of this work are as follows:

- The LANS NAS-GY membrane, operating for 112 hours at a current density of 50 mA/cm^2 , successfully transferred 2.8 moles of Na and concentrated a 13.6 M NaOH solution to 15.6 M with no observable membrane performance loss, high electrical efficiency, and high Na selectivity.
- Sodium transport efficiencies ranged from 93 to 106% while the average efficiency was 99%.
- The actual Na transport rate was in good agreement with the theoretical Na transport rate based on applied current. An average Na transfer rate of 10.2 kg/day/m^2 was observed.
- The NAS-GY membrane was highly selective to sodium. No transport of any cations or anions was detected except for Na and ^{137}Cs . The Na Selectivity with respect to ^{137}Cs was 2823 while the process produced a decontamination factor of 5717 with respect to ^{137}Cs .

Acronyms and Abbreviations

AC	alternating current
ADC	amperage direct current
CA	contamination area
DC	direct current
DDI	deionized, distilled water
Df	Decontamination factor
DOE	U.S. Department of Energy
EPDM	ethylene propylene diene monomer
EQL	estimated quantitation limit
GEA	gamma energy analysis
HDPE	high-density polyethylene
ICP	inductively coupled plasma
Kovar™	nickel-cobalt ferrous alloy material
LANS	Large Area NaSICON Structures
MDL	minimum detection limit
MP	multi-purpose
NAS-GY	A proprietary NaSICON formulation defined by Ceramatec Inc.
NaSICON	(Na) Super Ion Conductor
NIST	National Institute of Standards and Technology
OES	optical emission spectrometry
PNNL	Pacific Northwest National Laboratory
PP	polypropylene
PTFE	polytetrafluoroethylene
RE-NaSICON	rare-earth (Na) Super Ion Conductor
TIC	total inorganic carbon
TOC	total organic carbon
VDC	voltage direct current
WTP	Hanford Tank Waste and Treatment Immobilization Plant

Acknowledgments

The authors would like to acknowledge the following people for their significant contributions during testing: Igor Kutnyakov (PNNL), Dennese Smith (PNNL), and Keith Geiszler (PNNL). Also, for a thorough and quality technical review, the authors thank Brian Rapko (PNNL).

This work is funded through a sub-contract from Ceramatec Inc., who is funded by the Office of Science and Technology within the U.S. Department of Energy's Office of Environmental Management under Contract DE-FG07-04ID14622. Pacific Northwest National Laboratory is operated for the U.S. Department of Energy by Battelle under Contract DE-AC05-76RL01830.

Contents

Summary	iii
Acronyms and Abbreviations	v
Acknowledgments	vii
1.0 Introduction	1.1
1.1 Report Scope	1.1
1.2 LANS Test Objectives	1.1
1.3 Electrochemical Separation Process Description	1.1
2.0 Experimental Apparatus and Procedure	2.1
2.1 Membrane Fabrication, Composition, and Dimensions	2.1
2.2 Bench-Scale Electrochemical Test System	2.1
2.3 Sampling and Sample Analysis	2.4
2.4 Tank Waste Feed Preparation and Composition	2.4
3.0 Experimental Results and Discussion	3.1
3.1 Definition of Performance Parameters	3.1
3.2 Bench-Scale Testing of 2.4-inch LANS NAS-GY Single Disk	3.1
4.0 Conclusions	4.1
5.0 References	5.1
Appendix A: Post-Testing LANS Cell Disassembly	5.1
Appendix B: ICP and GEA Result Sets	5.1
Appendix C: Simulant Feed Preparation and Composition	C.1

Figures

1.1. Schematic of an Electrochemical Process Using the NaSICON Membrane.....	1.2
2.1. Bench-Scale Electrochemical Salt-Splitting System	2.2
2.2. Bench-Scale Electrochemical Cell System: Electro MP (ElectroCell AB)	2.3
3.1. Voltage and Current Density During LANS Testing	3.3
3.2. Sodium Transport Rate Comparison During LANS Testing (Catholyte Results)	3.4
3.3. Sodium Transport Rate Comparison During LANS Testing (Anolyte Results).....	3.4

Tables

2.1. Group 5 and 6 Tank Waste Composition by ICP-OES.....	2.5
2.2. Group 5 and 6 Tank Waste Radionuclide Composition by GEA (Pre-spike).....	2.5
2.3. Group 5 and 6 Tank Waste Radionuclide Composition by GEA (Post-spike).....	2.6
3.1. Summary of Experimental Conditions.....	3.2

1.0 Introduction

1.1 Report Scope

This report presents a summary of recent (**Na**) **Super Ion Conductor** (NaSICON) membrane testing activities associated with separating and recycling sodium from radioactive wastes. Testing activities focused on bench-scale testing with actual radioactive tank waste using the Large Area NaSICON Structures (LANS) type membrane. Details regarding NaSICON materials and membrane development, research history, and related experimental work can be found in a previous report (Fountain et al. 2009).

1.2 LANS Test Objectives

The primary goal of the current NaSICON sodium recycling work is to obtain information regarding the process performance using actual radioactive tank wastes under long-term testing conditions (~120 hours). Specific test objectives include the following:

- Determine the Na transfer rate and transfer efficiency of the membrane while operating at a 50 mA/cm² current density.
 - A direct function of current density and total membrane surface area, Na transfer rates dictate the size of the future production facility and ultimately allow a determination of economic viability of this technology.
- Determine the selectivity of the membranes for the various waste components relative to sodium. Components of greatest interest include aluminum, potassium, and the radionuclides (e.g., ⁹⁰Sr, ¹³⁷Cs).
 - Good membrane selectivity with respect to sodium is important since this increases the efficiency of the process and the purity of the caustic product.
- Verify LANS membrane and edge seal integrity while operating for approximately 120 hours.
 - Maintaining a stable membrane structure is key to long-term operating success of the caustic recycle process. Further, the edge seal between the membrane and the support scaffold is key to preventing the transport of undesirable ions from waste to the caustic product, which could jeopardize the successful application of the sodium separation process.

1.3 Electrochemical Separation Process Description

An electrochemical salt-splitting process based on inorganic ceramic membranes is shown in **Error! Reference source not found.** This process shows promise as a means to mitigate the impact of Na by enabling the separation and recycling of Na from the radioactive wastes. In this process, the waste is added to the anode compartment, and an electrical potential is applied to the cell. The ceramic membrane allows the selective transport of Na⁺ ions to the cathode compartment while most other cations (e.g., K⁺, Cs⁺) and anions are left behind (i.e., rejected) in the anode compartment. The net result of this process is transport of sodium ions from the radioactive waste to the NaOH solution to create a concentrated caustic solution. The charge balance in the anode compartment is maintained by generating

H⁺ from the electrolysis of water. Nitrite oxidation forming sodium nitrate also occurs to a minor degree in the anode. The charge balance in the cathode is maintained by generating OH⁻, either from the electrolysis of water or from oxygen and water using an oxygen gas diffusion cathode. The normal gaseous products of the electrolysis of water are oxygen at the anode and hydrogen at the cathode. Potentially flammable gas mixtures can be prevented by providing adequate volumes of a sweep gas, using an alternative reductant, or destroying the hydrogen as it is generated. As H⁺ is generated in the anode compartment, the pH drops. Producing OH⁻ in the cathode compartment results in a rise in pH as the Na hydroxide product is produced.

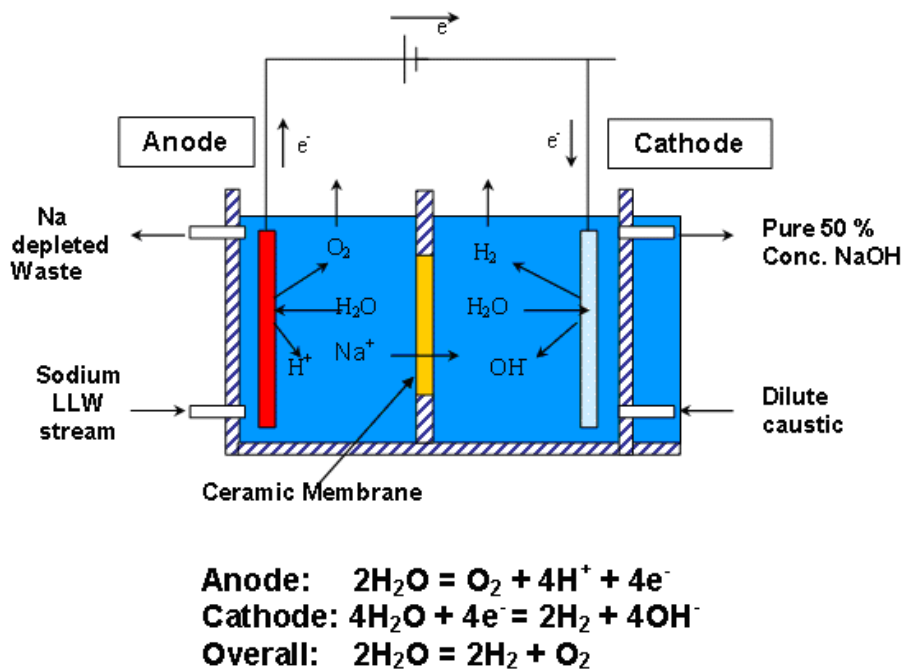

Figure 1.1. Schematic of an Electrochemical Process Using the NaSICON Membrane

The remainder of this report describes 1) the experimental approach and procedures that were used in electrochemically testing the LANS membrane, 2) the composition of the feeds, and 3) the experimental results.

2.0 Experimental Apparatus and Procedure

2.1 Membrane Fabrication, Composition, and Dimensions

Several different membrane compositions and three different disk sizes have been tested previously (Kurath 1997b). Results from this previous work indicate that the NAS-GY (a proprietary NaSICON formulation defined by Ceramtec Inc.) membrane material possesses the best combination of ion conductivity and stability. Ceramtec Inc. has selected this material composition as their primary candidate for commercialization and further advanced their development of NaSICON membranes by fabricating LANS.

The LANS membranes were developed to increase membrane strength, performance and operating lifetime while observing a reduction in power consumption when compared to monolith ceramic structures. They are fabricated using a tape cast approach. The LANS membrane used in this work incorporated cross-support structures and a 200 to 250-micron active transport cross section. Ceramtec identified this specific membrane as NAS-GYR6-152 (2.4-in diameter LANS).

2.2 Bench-Scale Electrochemical Test System

Figure 2.1 shows a schematic of the electrochemical flow cell used for testing. Separate flow loops were provided for the anolyte and catholyte solutions. Each loop consisted of a solution storage reservoir, pump, and flow-control meter. An inert gas purge line was supplied to the catholyte solution container to prevent the buildup of potentially flammable gases generated in the cathode. A simple ambient air condenser was placed on the cathode outlet line to recover any evaporation losses. The operating temperature was maintained with two 6 × 12-inch fiberglass reinforced silicone-rubber heat blankets capable of 90 W outputs and controlled by Omega CN7100 temperature controllers with Omega K-type (Model# HKQSS-18G-12) thermocouples to provide temperature feedback. Actual reservoir and cell outlet temperatures were monitored manually with a Fluke 54II handheld thermometer and Omega PFA-coated T-type thermocouples (Model# CPSS-18G-12-PFA).

Direct current (DC) power was supplied with “The BOSS” model 730 electrochemical process control unit manufactured by the Electrosynthesis Company. Voltage (0 to 60 voltage direct current [VDC]) or current (0 to 50 amperage direct current [ADC]) could be directly set. The LANS experiment was conducted under constant current control. The process control unit also monitored various experimental parameters and automatically shut down the system if the parameters were exceeded. Voltage and current output signals from the process control unit were recorded with an Agilent 34970A data-acquisition system using a 34901A hardware board and stored on a computer hard disk.

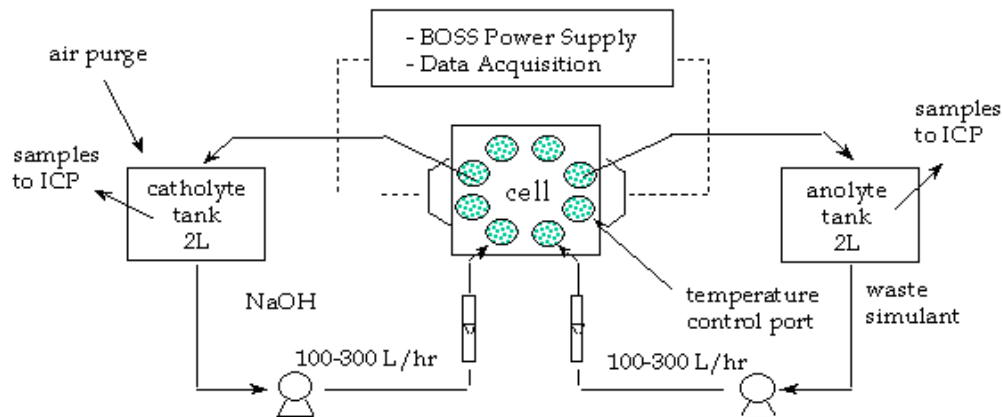

Figure 2.1. Bench-Scale Electrochemical Salt-Splitting System

The anolyte and catholyte reservoirs consisted of polypropylene (PP) tanks with a 2-L capacity. The fittings for the tank were of the Swagelok™ type. The tubing material consists of polytetrafluoroethylene (PTFE) tubing ($\frac{7}{16}$ -inch ID \times $\frac{1}{2}$ -inch OD) with PP fittings. Two caustic-resistant, magnetically driven centrifugal pumps (Little Giant model # 4-MD-SC) were used to circulate the catholyte and anolyte solutions through their respective loops. Both pumps were rated at 0.1 hp. Solution flow rates were monitored and controlled with 4-inch Key Instrument rotameters (Model# FR4L54SVEPDM) with a flow range of 0 to 180 L/h (water basis). Flow rates from 108 to 156 L/h were maintained. Solution loop and transmembrane pressures were monitored with corrosive service gauges capable of 0 to 15 psig and incremental markings of 0.25 psig each.

The electrochemical cell (Figure 2.2) is a modified Electro multi-purpose (MP) model (ElectroCell AB) for bench-scale testing. This is a scaled-down version of a production unit, the Electro Prod Cell (ElectroCell AB), which has an electrode area of 4000 cm². The electrodes were Kovar™ (nickel-cobalt ferrous alloy material) (anode) and nickel (cathode) with a projected surface area of 100 cm². The cell materials of construction are

- scaffold—HDPE
- flow promoter—PE
- gaskets—ethylene propylene diene monomer (EPDM) rubber
- metal endplates and bolts—316 stainless steel.

Separate flow channels are provided in the cell for circulating cooling/heating water for temperature control, but this feature was not used. Turbulence promoters were inserted between the scaffold and the electrode surface to promote solution mixing. A minimum flow rate of 60 L/h is specified by the manufacturer for the MP cell.

The 6.1-cm diameter ceramic LANS membrane, with a NAS-GYR6-152 formulation, was incorporated into a scaffold consisting of 0.635-cm ($\frac{1}{4}$ -in.) HDPE and identified by Ceramatec as LANS 2.4 03. The membrane disk was sealed at the edge and offered an active membrane surface area of 13.6 cm². The LANS membrane was new and unused prior to the radioactive test at PNNL. Prior to delivery

to PNNL, Ceramatec completed a successful leak test using a procedure incorporating methanol to verify seal integrity.

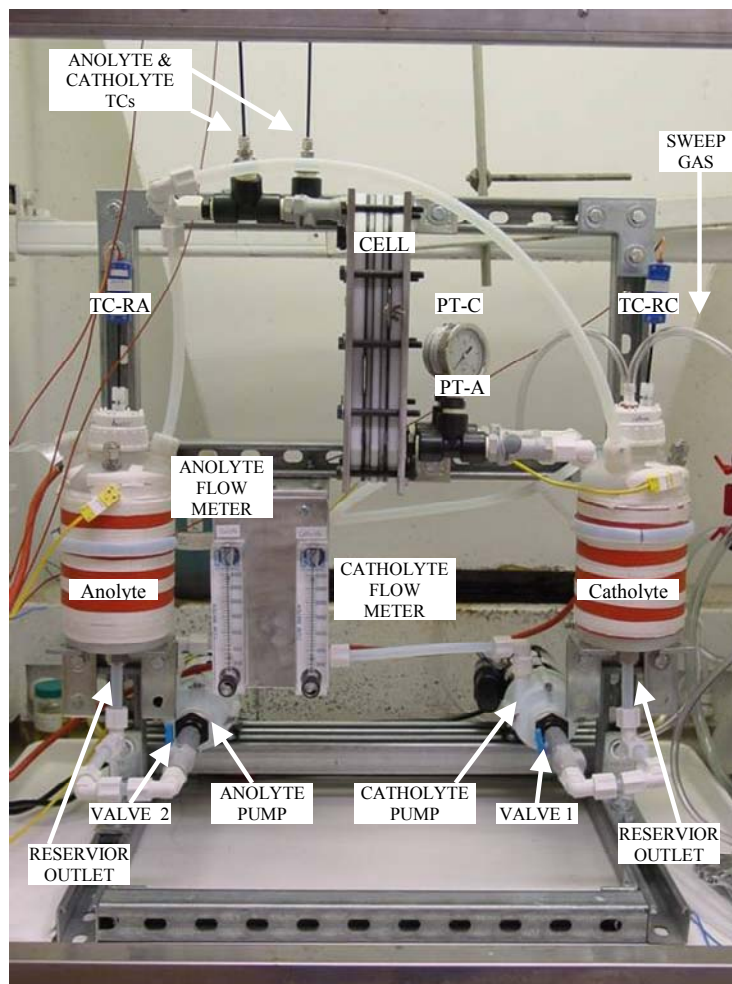

Figure 2.2. Bench-Scale Electrochemical Cell System: Electro MP (ElectroCell AB)

The system was placed inside a contamination area (CA) fumehood while operating in a batch recycle mode with initial feedstock volumes of approximately 1.5 L. The anolyte solution was a composited sample of tank waste termed as Group 5 and 6 tank waste. The catholyte solution was prepared using reagent-grade 19 M NaOH and deionized, distilled water (DDI).

The period of testing was set at approximately 120 hours based on the current density target (50 mA/cm^2) and the OH^- concentration of the anolyte. As OH^- concentrations decrease during Na^+ transport, $\text{Al}(\text{OH})_3$ (Gibbsite) precipitates because of a drop in solubility as the anolyte solution becomes depleted of free OH^- , and the pH approaches 12. Solution pH levels are typically monitored with Hydrion microfine pH paper, but pH monitoring was deemed unnecessary in this case. In addition, since adequate levels of Na^+ and OH^- were predicted to exist during this test, no water, waste, or NaOH was added during testing. The temperature of the system was normally controlled at 40°C ($-1/+5^\circ\text{C}$).

2.3 Sampling and Sample Analysis

Sample volumes of approximately 5 mL were taken by disposable pipette at least every 8 hours from both the catholyte and anolyte reservoirs. It was important to minimize the sample volume since a substantial amount of Na could be removed from the system over the course of the experiment.

For major cation analysis, the process samples were analyzed with inductively coupled plasma-optical emission spectrometry (ICP-OES) on an Optima 3300DV ICP-OES instrument (Perkin Elmer, Waltham, MA). For ICP-OES analyses, high-purity calibration standards were used to generate calibration curves and to verify continuing calibration during the analysis.

Hydroxide analyses were completed using a Model 295 Multi-Function Auto Titrator (Denver Instrument Company, Denver, Colorado). A volume of standardized sulfuric acid was added to the sample to an endpoint of pH 4.5 to measure total alkalinity. The contributions of carbonate and bicarbonate were removed from the reported alkalinity data, which is reported in terms of meq of NaOH.

Select samples were also analyzed by gamma energy analysis (GEA) to investigate radionuclide concentrations. The analyses were made using 60% efficient intrinsic-germanium gamma detectors. All germanium counters were efficiency calibrated for distinct geometries using mixed gamma standards traceable to the National Institute of Standards and Technology (NIST). Spectral analysis was conducted using libraries containing most mixed-fission products, activation products, and natural decay products. Control samples were run throughout the analysis to ensure correct operation of the detectors.

2.4 Tank Waste Feed Preparation and Composition

Selecting the actual waste feed was constrained by the wastes that were available. The priority was to use a high-caustic, Cs-depleted supernate waste. A 1.5L tank-waste sample previously treated by ion exchange was located and deemed as representative tank-waste feed for conducting caustic recycle experiments. Table 2.1 and Table 2.2 identify the estimated constituent and radionuclide concentrations, respectively, and are based on analysis of samples obtained after cesium ion-exchange treatment (Fiskum et al. 2009). Details of the tank waste sample origin and processing are provided elsewhere (Fiskum et al. 2008, Fiskum et al. 2009). For purposes of reference in this report the composited Group 5 and 6 Cs-depleted supernatant tank waste will be referred to as “Group 5 and 6 tank waste.”

Table 2.1. Group 5 and 6 Tank Waste Composition by ICP-OES

Constituent	µg/mL	Constituent	µg/mL
Al	7294	Rh	[1.8]
As	<5.82	Ru	[1.9]
B	16.3	Se	<8.72
Ba	[0.42]	Si	31.4
Ca	[5.33]	Sn	<3.52
Cd	<0.42	Sr	<0.010
Cl	1070	Ti	<0.05
Cr	726	V	[0.54]
Cs	0	W	[22]
F	45.6	Zn	[3.83]
Fe	[1.37]	Zr	<0.17
Hg	0	U	<4.5
K	390	TIC	370
Li	[0.65]	TOC	2650
Mo	11.13	NO ₂	12700
Na	103400	NO ₃	43200
Ni	<0.36	OH	14241
Nd	0	PO ₄	2410
P	796	SO ₄	2310
Pb	<3.99	Oxalate	479
Pd	<0.87		

Concentrations less than 0.5 were rounded to zero.

Analyte uncertainties were typically within ±15%; results in brackets indicate that the analyte concentrations were greater than the minimum detection limit (MDL) and less than the estimated quantitation limit (EQL), and uncertainties were >15%.

Table 2.2. Group 5 and 6 Tank Waste Radionuclide Composition by GEA (Pre-spike)

Constituent	µCi/mL	Constituent	µCi/mL
¹³⁷ Cs	<8.0E-05	²³⁸ Pu	1.13E-05
⁶⁰ Co	<9.3E-05	²³⁹⁺²⁴⁰ Pu	7.40E-05
²⁴¹ Am	<2.8E-04	⁹⁰ Sr	1.52E-04

Note that ^{137}Cs , ^{60}Co , and ^{241}Am concentrations are below detection limits in the initial Group 5 and 6 tank waste feedstock. A radioactive ^{137}Cs spike was added to the feedstock waste bottle since one objective of these tests was to monitor any radionuclide transport across the membrane. Table 2.3 provides the radionuclide composition for the post-spike Group 5 and 6 tank waste feed.

Table 2.3. Group 5 and 6 Tank Waste Radionuclide Composition by GEA (Post-spike)

Constituent	$\mu\text{Ci/mL}$	Constituent	$\mu\text{Ci/mL}$
^{137}Cs	7.26E-02	^{238}Pu	<3.15E-01
^{60}Co	8.14E-05	$^{239+240}\text{Pu}$	<7.01E-01
^{241}Am	<1.39E-04	^{90}Sr	-

“-“ = radionuclide was not analyzed for

3.0 Experimental Results and Discussion

3.1 Definition of Performance Parameters

Key membrane performance parameters include the sodium-transport efficiency, sodium-transfer rate, and membrane selectivity. The sodium-transport efficiency was determined at various times during the experiment based on chemical analysis of samples. The sodium-transport efficiency, provided in Equation 3.1, is defined as the moles of sodium transported through the membrane relative to the total moles of electrons.

$$\text{Na Transport Efficiency} = \frac{\text{actual moles of Na transferred}}{I \times t / F} \quad (3.1)$$

Current, time, and Faraday's constant (96,484 amp-s/mol) are represented by I, t, and F, respectively. The sodium-transfer rate was determined with chemical analysis of each sample and then averaged over the length of the experiment. Finally, membrane selectivity for Na⁺ over other metal cations is represented by Equation 3.2:

$$\text{Sodium Selectivity} = \frac{\left(\frac{\text{moles of Na Transferred}}{\text{Initial Na Concentration}} \right)}{\left(\frac{\text{moles of Metal Transferred}}{\text{Initial Metal Concentration}} \right)} \quad (3.2)$$

where the moles of materials transferred are based on the catholyte analyses at the start and the end of testing, while initial concentrations are based on initial anolyte analyses.

The decontamination factor (Df), provided in Equation 3.3, is frequently used in the radiological protection arena and represents the effectiveness of a decontamination process. Generally, Df values >1,000 are excellent while <10 are poor.

$$\text{Decontamination Factor (Df)} = \frac{\text{initial anolyte radionuclide concentration}}{\text{final catholyte radionuclide concentration}} \quad (3.3)$$

3.2 Bench-Scale Testing of 2.4-inch LANS NAS-GY Single Disk

A single experiment using a 2.4-inch LANS NAS-GYR6-152 membrane was completed using the ElectroCell MP system described previously. The cell was operated in the batch mode, at 40°C, with no material additions during testing. The current density was maintained at 50mA/cm² based on the exposed membrane area equal to 13.6 cm². Both the anolyte and catholyte reservoirs were sampled at 8 hour intervals. Current, temperature, flow rate, and voltage were monitored and recorded throughout the experiment.

A Group 5 and 6 radioactive tank waste charge of 1799.2 g (~1.5 L) was placed into the anolyte reservoir and 2052.0 g (~1.5 L) of 14 M NaOH was charged to the catholyte reservoir. No system breach or other modifications were performed on the electrochemical cell received from Ceramatec. Experimental conditions are provided in Table 3.1.

Figure 3.1 displays current density and applied voltage over the course of the LANS membrane experiment. The current density remained relatively steady, varying less than 0.46 mA/cm² from 50mA/cm² while the voltage rose from an initial minimum of 2.46 V to a maximum of 2.68 V just before stopping the experiment. Note that the power and fluid flow to the electrochemical was removed at the elapsed time between 4.0 and 4.2 hours in an attempt to correct a small leak at the anolyte inlet fitting. No significant material loss was recorded, and no impact on the experimental results is expected.

Visual observations of both the anolyte and catholyte solutions during the experiment, and up to 2 weeks after testing, showed no signs of solids precipitation. Further, comparing ICP samples of the anolyte, the initial Al concentration (6610 µg/mL) and final Al concentration (6540 µg/mL) were equivalent within analytical uncertainty, and this suggests that gibbsite remained soluble in the solution. The Electro MP cell was disassembled layer-by-layer and photographed to investigate any abnormal corrosion, damage, and possible solids precipitation. These photos are provided in Appendix A.

Testing was stopped based on a pre-determined plan to operate close to 120 hours. The actual sodium transport time was 112 hours.

Table 3.1. Summary of Experimental Conditions

Operational Parameter	Range or Value
Membrane Type	NAS GYR6-152 (2.4-in. LANS)
Membrane Thickness (mm)	0.2 to 0.25
Membrane Diameter (cm)	6.1
Current Density (mA/cm ²)	50
Applied Current (Min-Max Amps)	0.68-0.69
Applied Current (Min-Max Volts)	2.45-2.68
Temperature (°C)	40-45
Active Membrane Area (cm ²)	13.6
Anolyte Flow Rate (L/min)	2.6
Catholyte Flow Rate (L/min)	1.8-2.0
Catholyte (M NaOH)	13.6
Operating ΔP (psig)	2.1
Initial Sodium in Anolyte (moles)	4.09
Final Sodium in Anolyte (moles)	1.08
Initial Sodium in Catholyte (moles)	19.65
Final Sodium in Catholyte (moles)	21.07

Table 3.1 (contd)

Na Transport Efficiency (%)	93-106
Avg. Na Transport Rate (kg/day/m ²)	10.2
Operating Time (h)	112

Samples were obtained every 8 hours from both the catholyte and anolyte. A representative group of the samples were then submitted for analysis, which included OH titration, ICP-OES (cations), and radionuclide identification by GEA.

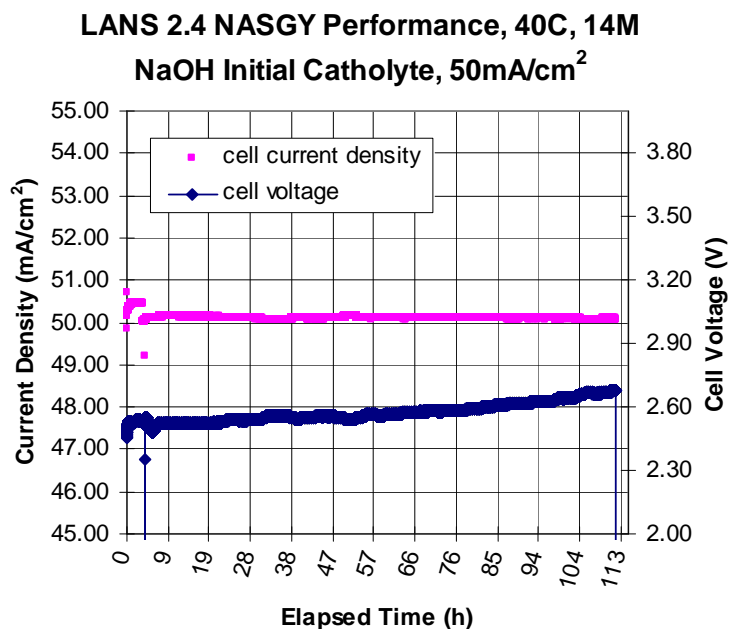

Figure 3.1. Voltage and Current Density During LANS Testing

Figure 3.2 and Figure 3.3 both provide a comparison between the theoretical sodium transport and the actual sodium transport determined by OH⁻ titration analyses of the catholyte and anolyte solutions, respectively. Figure 3.3 illustrates a good agreement between theoretical and the actual sodium transport rate while Figure 3.2 does not. The theoretical transport rate assumes that all applied current was involved in electron transfer.

**LANS 2.4 NASGY Performance, 40C, 13.6M
NaOH, 50mA/cm² (Catholyte Results)**

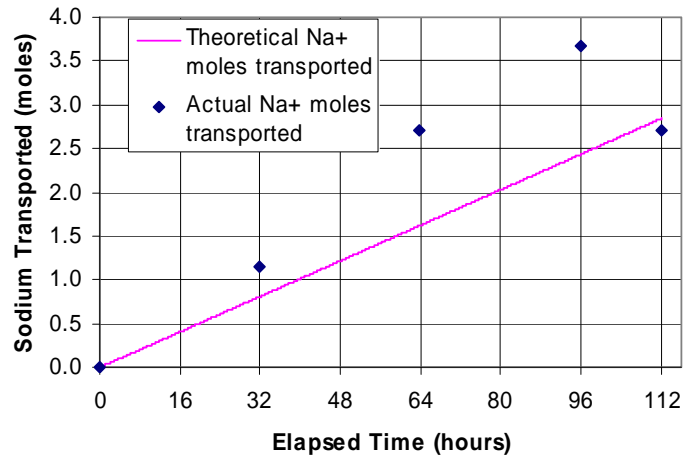

Figure 3.2. Sodium Transport Rate Comparison During LANS Testing (Catholyte Results)

**LANS 2.4 NASGY Performance, 40C, 14M
NaOH, 50mA/cm² (Anolyte Results)**

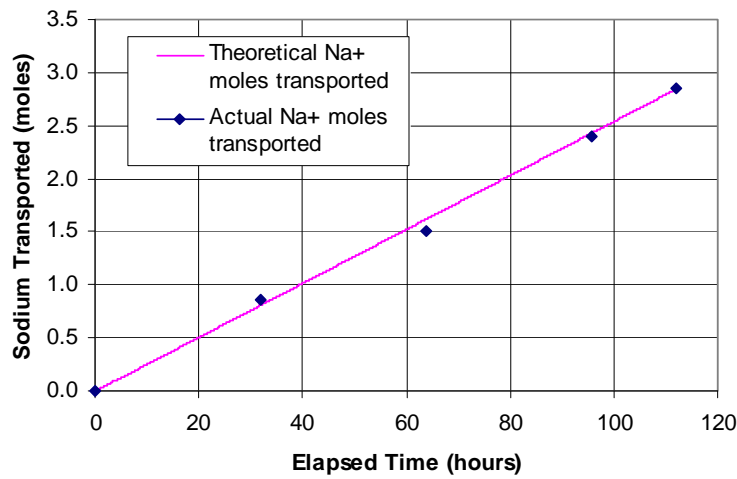

Figure 3.3. Sodium Transport Rate Comparison During LANS Testing (Anolyte Results)

The catholyte results are suspected to be in error from a combination of sample dilution for analysis and errors in sample aliquots due the high NaOH viscosity of the catholyte solution. The OH⁻ titration results are significantly influenced by the accuracy of the titrated volume, and high-viscosity materials often lead to volume errors when pipeting.

The sodium transport efficiency was determined through OH⁻ titration results on the anolyte samples. The calculated sodium transport efficiencies varied between 93 and 106% while the average was 99%. The uncertainty for this OH⁻ titration was estimated at $\pm 5\%$ based on calibration check standards and assuming a 3 standard deviation range. The average sodium transfer rate was 10.2 kg/day/m² and is

consistent with transfer rates obtained with 3.5-inch diameter NAS-GY membranes tested in early 2008 (Fountain et al. 2009).

The selectivity (Equation 3.2) of the LANS NAS-GY membrane towards sodium is an important performance parameter in the tank-waste treatment process because low membrane selectivity towards undesirable cations and radionuclides degrades the purity of the recycled material (19 M NaOH) and can increase dose to operators. Based on ICP-OES analysis of the catholyte and anolyte, no discernable transport of non-Na cations was observed. ICP-OES calibration check standards varied no more than 7% assuming 3 standard deviations. However, high concentrations of Na in both the anolyte and catholyte can saturate the ICP-OES system detector and required large sample dilutions. For this reason, it is assumed that the uncertainty of the ICP-OES results are $\pm 15\%$. GEA indicated that about 0.02% of the initial ^{137}Cs in the anolyte was transported to the catholyte. Full GEA results are provide in Appendix A. No other radionuclides were transported and measured in the catholyte solution above detection limits. The sodium selectivity with respect to ^{137}Cs was 2823. Both ICP and GEA results demonstrate that the LANS NAS-GY membrane was several thousand times more selective to Na than ^{137}Cs and also confirm that o-ring and membrane integrity were maintained during the test.

A Df value is frequently used in the radiological protection arena and represents the effectiveness of a decontamination process. Df values generally $>1,000$ are excellent while <10 are poor. The only radionuclide detected in the catholyte was ^{137}Cs , and a Df value of 5585 was calculated using Equation 3.3. The extremely high Dfs observed during the present testing indicate that the caustic recycle process will generate a very-high-purity caustic product with dose rates approximately 5500 times less than the initial waste stream.

4.0 Conclusions

A NaSICON membrane in the LANS configuration and a proprietary NAS-GY formulation was electrochemically tested in a bench-scale apparatus with Group 5 and 6 tank waste to determine the membrane performance when actively transporting Na for approximately 5 days. Results of this work are as follows:

- The LANS NAS-GY membrane, operating for 112 hours at a current density of 50 mA/cm², successfully transferred 2.8 moles of Na and concentrated a 13.6 M NaOH solution to 15.6 M with no observable membrane performance loss, high electrical efficiency, and high Na selectivity.
- Sodium transport efficiencies ranged from 93 to 106% while the average efficiency was 99%.
- The actual Na transport rate was in good agreement with the theoretical Na transport rate based on applied current. An average Na transfer rate of 10.2 kg/day/m² was observed.
- The NAS-GY membrane is highly selective to sodium. No transport of any cations or anions was detected except for Na and ¹³⁷Cs. The Na selectivity with respect to ¹³⁷Cs was 2823 while the process produced a decontamination factor of 5717 with respect to ¹³⁷Cs.

5.0 References

Fiskum SK, AE Kozelisky, EC Buck, GL Lumetta, RC Daniel, PJ MacFarlan, KE Draper, BK McNamara, MK Edwards, RA Peterson, TL Hubler, SI Sinkov, LK Jagoda, LA Snow, ED Jenson, and RG Swoboda. 2008. *Characterization and Leach Testing for REDOX Sludge and S-Saltcake Actual Waste Sample Composites*. WTP-RPT-157, Rev. 0, PNNL-17368, Battelle – Pacific Northwest Division, Richland, Washington.

Fiskum SK, KE Draper, PJ MacFarlan, JM Billing, MK Edwards, RA Peterson, EC Buck, ED Jenson, RW Shimskey, RC Daniel, AE Kozelisky, and LA Snow. 2009. *Laboratory Demonstration of the Pretreatment Process with Caustic and Oxidative Leaching Using Actual Hanford Tank Waste*. WTP-RPT-171, Rev. 0, PNNL-18007, Battelle—Pacific Northwest Division, Richland, Washington.

Fountain MS, DE Kurath, GJ Sevigny, AP Poloski, J Pendleton, S Balagopal, M Quist, and D Clay. 2009. *Caustic Recycle from Hanford Tank Waste Using NaSICON Ceramic Membrane Salt Splitting Process*. PNNL-18216, Battelle—Pacific Northwest Division, Richland, Washington.

Kurath DE, GW Hollenberg, J Jue, J Smith, AV Virkar, S Balagopal, and V Sutija. 1997a. “Salt Splitting Using Ceramic Membranes.” *Sep. Sci. Tech.* 32:55-572.

Kurath DE, KP Brooks, GW Hollenberg, (PNNL), DP Sutija, T Landro, and S Balagopal (Ceramatec). 1997b. “Caustic Recycle from High-salt Nuclear Wastes Using a Ceramic-membrane Salt-splitting Process.” *Separation and Purification Technology* 11:185–198.

Appendix A

Post-Testing LANS Cell Disassembly

Note: LANS membrane experiment cell disassembly. Pictures are in order. As each layer was removed, the layer was flipped over and laid to the left side.



Figure A.1. Cell Bolts Removed



Figure A.2. Discoloration on the Backside of the Support Plate at the Catholyte Inlet Was Observed and Cause Unknown

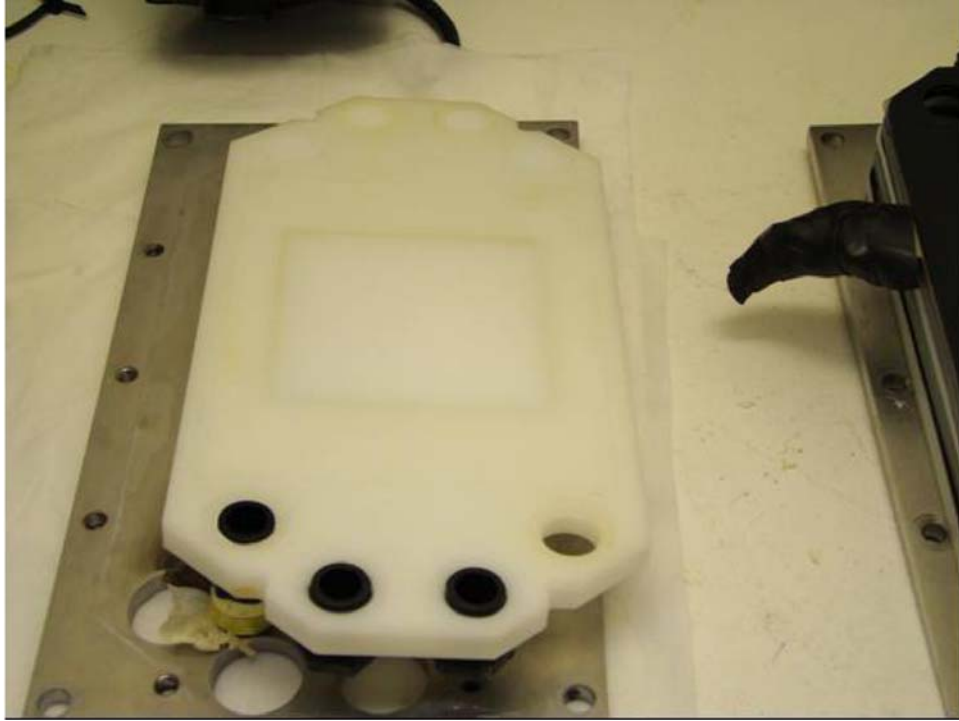

Figure A.3. No Solids or Discoloration Observed on the Support Scaffold

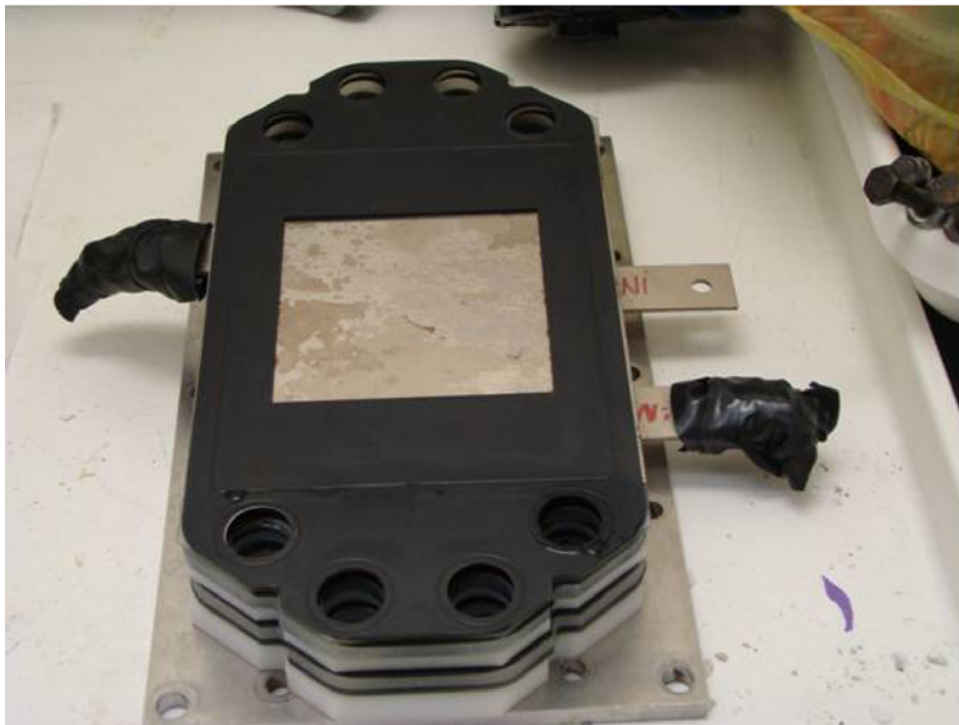

Figure A.4. Back Side of Kovar™ Electrode Showed Irregular Spotting



Figure A.5. Membrane Side of the Kovar™ Electrode. Discoloration Appears to Be Corrosion Byproducts

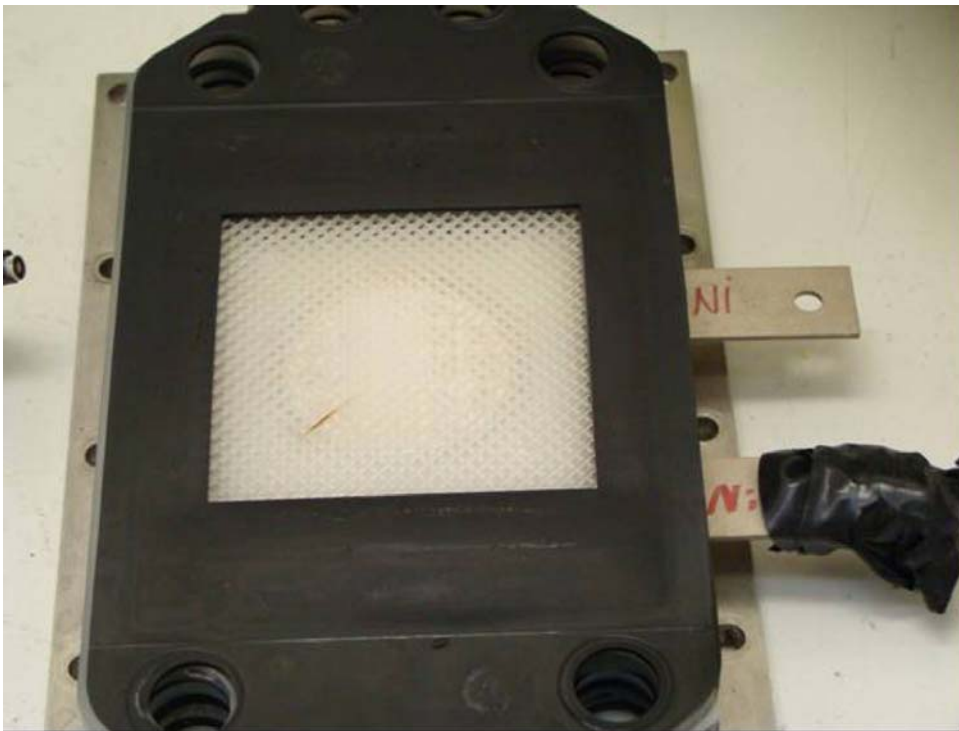

Figure A.6. Kovar™ Electrode Side of the Flow Promoter. No solids observed on the flow promoter. The small discoloration mark was similar in color to the material observed on the surface of the Kovar™ (anode) electrode.



Figure A.7. Membrane Side of the Flow Promoter. No solids observed on the flow promoter.



Figure A.8. LANS Membrane on the Anode (Kovar™ Electrode) Side. No irregular observations.



Figure A.9. LANS Membrane on the Cathode (Nickel Electrode) Side. No irregular observations.



Figure A.10. Membrane Side of the Cathode Side of Flow Promoter. No irregular observations.



Figure A.11. Nickel Electrode Side of Flow Promoter. No irregular observations.



Figure A.12. Membrane Side of the Nickel (Cathode) Electrode. Relatively uniform coloration.



Figure A.13. Back Side of Nickel Electrode. Interesting shadow impression of membrane. Discoloration surrounding membrane shadow.

Appendix B

ICP and GEA Result Sets

Table B.1. GEA Results for Decontamination Factor Calculation

Analyte	LANS Test (13.6M NaOH Catholyte)		
	Anolyte Initial (pCi/ml)	Catholyte Final (pCi/ml)	Df (initial/final)
Actinium-228	<4.00E1	<8.70E0	-
Americium-241	<1.39E2	<9.42E0	-
Americium-243	<4.98E1	<3.37E0	-
Antimony-124	<5.81E0	<2.29E0	-
Antimony-125	<1.88E2	<7.83E0	-
Antimony-126	<1.84E1	<2.65E0	-
Barium-133	<7.44E1	<3.87E0	-
Bismuth-210	<7.29E1	<4.25E0	-
Bismuth-211	<3.42E2	<5.22E1	-
Bismuth-214	<2.39E1	<5.30E0	-
Cadmium-109	<8.69E2	<4.78E1	-
Cerium-139	<3.34E1	<2.43E0	-
Cerium-144	<2.19E2	<1.60E1	-
Cesium-134	<1.33E1	<2.46E0	-
Cesium-137	7.26E+04	1.27E+01	5717
Chromium-51	<4.02E2	<2.19E1	-
Cobalt-57	<2.73E1	<1.99E0	-
Cobalt-60	8.14E+01	<2.35E0	>35
Curium-243	<9.81E1	<7.07E0	-
Curium-245	<8.06E1	<5.81E0	-
Europium-152	<2.07E1	<7.99E0	-
Europium-154	<2.22E1	<4.23E0	-
Europium-155	<7.79E1	<5.38E0	-
Francium-223	<1.05E3	<6.26E1	-
Gadolinium-153	<7.62E1	<5.62E0	-
Iodine-131	<5.63E1	<2.53E0	-
Iron-59	<1.69E1	<4.84E0	-
Lead-210	<3.45E3	<4.99E2	-
Lead-211	<4.03E2	<7.13E1	-
Lead-212	<8.31E1	<5.08E0	-
Lead-214	<1.17E2	<6.01E0	-
Manganese-54	<1.12E1	<2.46E0	-
Mercury-203	<4.80E1	<2.65E0	-
Neptunium-237	<2.57E2	<1.40E1	-
Niobium-94	<1.11E1	<2.39E0	-
Niobium-95	<1.17E1	<2.33E0	-
Niobium-95m	<1.43E2	<8.52E0	-
Plutonium-238	<3.15E5	<2.29E4	-
Plutonium-239	<3.79E5	<2.78E4	-
Plutonium-240	<3.22E5	<2.32E4	-
Potassium-40	<4.43E1	<3.49E1	-

Table B.1. (contd)

Analyte	LANS Test (13.6M NaOH Catholyte)		
	Anolyte Initial (pCi/ml)	Catholyte Final (pCi/ml)	Df (initial/final)
Protactinium-231	<1.66E3	<9.08E1	-
Protactinium-233	<1.08E2	<5.68E0	-
Protactinium-234	<7.14E1	<7.24E0	-
Protactinium-234m	<1.24E3	<3.01E2	-
Radium-223	<2.69E2	<1.54E1	-
Radium-224	<9.06E2	<5.42E1	-
Radium-226	<9.28E2	<5.86E1	-
Radon-219	<3.71E2	<2.11E1	-
Radon-220	<3.78E4	<2.05E3	-
Radon-221	<1.51E2	<9.50E0	-
Rubidium-83	<9.77E1	<4.39E0	-
Rubidium-86	<1.19E2	<2.55E1	-
Ruthenium-103	<5.62E1	<2.51E0	-
Ruthenium-106	<3.57E2	<2.34E1	-
Selenium-75	<6.09E1	<3.55E0	-
Silver-108m	<1.42E1	<2.40E0	-
Silver-110	<1.47E1	<3.01E0	-
Silver-110m	<1.47E1	<3.02E0	-
Sodium-22	<7.65E0	<2.74E0	-
Strontium-85	<4.68E1	<3.08E0	-
Technetium-95m	<4.06E1	<3.35E0	-
Technetium-99m	<2.68E1	<2.00E0	-
Thallium-208	<4.10E1	<2.72E0	-
Thorium 232	<2.73E4	<1.90E1	-
Thorium-227	<3.20E2	<7.62E2	-
Thorium-228	<1.30E4	<6.25E2	-
Thorium-230	<9.44E3	<4.01E2	-
Thorium-231	<5.52E3	<1.91E3	-
Thorium-234	<8.49E2	<5.93E1	-
Tin-113	<7.61E1	<3.34E0	-
Tin-126	<7.03E1	<3.83E0	-
Uranium 235	<2.29E2	<1.70E1	-
Uranium 238	<4.40E2	<3.30E1	-
Yttrium-88	<3.22E0	<2.11E0	-
Zinc-65	<2.02E1	<4.72E0	-
Zirconium-95	<2.10E1	<4.36E0	-

nd = not detected; Values reported with "<" are below Minimum Detection Activity (MDA)

Table B.2. Complete GEA Results for Initial and Final Anolyte and Catholyte Samples

	LANS Test (13.6M NaOH Catholyte)					
	Anolyte Initial (µg/L)	Anolyte Final (µg/L)	Anolyte % Change	Catholyte Initial (µg/L)	Catholyte Final (µg/L)	Catholyte % Change
Aluminum	6.61E+06	6.54E+06	1.1	<1.74E4	<1.74E4	nd
Antimony	<7.79E4	<7.79E4	nd	<7.79E4	<7.79E4	nd
Arsenic	<1.70E5	<1.70E5	nd	<1.70E5	<1.70E5	nd
Barium	<6.49E3	<6.49E3	nd	<6.49E3	<6.49E3	nd
Beryllium	<2.36E3	<2.36E3	nd	<2.36E3	<2.36E3	nd
Bismuth	<3.47E4	<3.47E4	nd	<3.47E4	<3.47E4	nd
Boron	<7.01E4	<7.01E4	nd	<7.01E4	<7.01E4	nd
Cadmium	<2.71E3	<2.71E3	nd	<2.71E3	<2.71E3	nd
Calcium	<2.89E4	<2.89E4	nd	<2.89E4	<2.89E4	nd
Chromium	6.99E+05	6.93E+05	0.9	<3.56E3	<3.56E3	nd
Cobalt	<7.71E3	<7.71E3	nd	<7.71E3	<7.71E3	nd
Copper	<4.22E3	<4.22E3	nd	<4.22E3	<4.22E3	nd
Iron	<9.87E3	<9.87E3	nd	<9.87E3	<9.87E3	nd
Lead	<1.54E4	<1.54E4	nd	<1.54E4	<1.54E4	nd
Lithium	<4.09E4	<4.09E4	nd	<4.09E4	<4.09E4	nd
Magnesium	<5.01E3	<5.01E3	nd	<5.01E3	<5.01E3	nd
Manganese	<2.54E3	<2.54E3	nd	<2.54E3	<2.54E3	nd
Molybdenum	<2.12E4	<2.12E4	nd	<2.12E4	<2.12E4	nd
Nickel	<9.45E3	<9.45E3	nd	<9.45E3	<9.45E3	nd
Phosphorus	7.30E+05	7.25E+05	0.7	<9.46E4	<9.46E4	nd
Potassium	<5.07E5	<5.07E5	nd	<5.07E5	<5.07E5	nd
Rhenium	<2.41E4	<2.41E4	nd	<2.41E4	<2.41E4	nd
Selenium	<2.57E5	<2.57E5	nd	<2.57E5	<2.57E5	nd
Silicon	<5.00E5	<5.00E5	nd	<5.00E5	<5.00E5	nd
Silver	<2.05E4	<2.05E4	nd	<2.05E4	<2.05E4	nd
Sodium	9.57E+07	5.39E+07	43.7	2.78E+08	3.38E+08	-21.6
Strontium	<4.20E3	<4.20E3	nd	<4.20E3	<4.20E3	nd
Sulfur	7.35E+05	7.72E+05	-5.0	<1.84E5	<1.84E5	nd
Thallium	<5.19E4	<5.19E4	nd	<5.19E4	<5.19E4	nd
Titanium	<3.58E3	<3.58E3	nd	<3.58E3	<3.58E3	nd
Vanadium	<4.95E4	<4.95E4	nd	<4.95E4	<4.95E4	nd
Zinc	<1.69E4	<1.69E4	nd	<1.69E4	<1.69E4	nd
Zirconium	<5.00E4	<5.00E4	nd	<5.00E4	<5.00E4	nd

Values reported with "<" are below Estimated Sample Quantitation Limit (EQL), nd = not detected

Appendix C

Simulant Feed Preparation and Composition

A simulant recipe was developed during this work to mirror the non-radioactive components identified in the Group 5 and 6 tank waste sample. Table C.1 identifies the estimated constituent concentrations in the simulant. Ceramatec Inc. prepared the simulant based on the recipe provided by PNNL and used the material for non-radioactive testing of the LANS NAS-GY membrane at their facility.

Table C.1. Group 5 and 6 Simulant Initial Composition

Constituent	µg/mL	Constituent	µg/mL
Al	7080	Rh	-
As	-	Ru	-
B	16	Se	-
Ba	-	Si	32
Ca	-	Sn	-
Cd	-	Sr	-
Cl	1070	Ti	-
Cr	738	V	-
Cs	-	W	7
F	46	Zn	-
Fe	-	Zr	-
Hg	-	U	-
K	400	CO ₃	13241
Li	1	TOC	65
Mo	11	NO ₂	12700
Na	101731	NO ₃	43246
Ni	-	OH	43501
Nd	-	PO ₄	2410
P	786	SO ₄	2310
Pb	-	Oxalate	729
Pd	-		

No material was added to simulant for elements with “-“

TOC = Total Organic Carbon (calculated from recipe)

Distribution

**No. of
Copies**

**No. of
Copies**

OFFSITE

ONSITE

2 Ceramatec Inc.
2425 South 900 West
Salt Lake City, Utah 84119
Attn: S. Balagopal
S. Bhavaraju

2 Pacific Northwest National Laboratory
M. S. Fountain P7-27
G. J. Sevigny P7-27