

Surface Selective Membranes for Carbon Dioxide Separation

David R. Luebke, Henry W. Pennline, and Christina R. Myers
United States Department of Energy
National Energy Technology Laboratory
P.O. Box 10940
Pittsburgh, PA 15236-0940
Fax: (412) 386-6004

ABSTRACT

Membranes, though relative newcomers to the world of gas separations, have gained acceptance in the only currently practiced operation comparable to the large scale carbon dioxide removal from flue or fuel gas, natural gas sweetening. Several factors have helped to speed the adoption of new membrane technologies by the natural gas industry. The one most often discussed is the relative ease of installation and maintenance of prefabricated membrane sleds which make them nearly universally preferred in remote locations. Additionally, membrane gas sweetening leaves the product stream at high pressure, is more environmentally benign than traditional methods, and occupies a smaller footprint in the plant.

Given these advantages, it should not be surprising that a great deal of research has been conducted exploring the use of membranes for the separation of CO₂ from other mixtures, such as those found in conventional and advanced power generation systems. Membrane removal of CO₂ from flue gas is difficult due to low driving force and the presence of trace contaminants which are molecularly very similar to CO₂, such as SO₂. Separation of CO₂ from fuel gas is more advantageous since it is already at high pressure, possesses a higher concentration of CO₂ after water gas shift, and contains benign contaminants in reduced forms such as H₂S.

In this study, hybrid membranes have been developed for the selective separation of CO₂ from mixtures containing H₂. Beginning with commercially available Pall alumina membrane tubes with nominal pore diameter of 5 nm, hybrids were produced by silation with a variety of functionalities designed to facilitate the selective adsorption of CO₂ onto the pore surface. The goal is to produce a membrane which can harness the power of surface diffusion to give the selectivity of polymer membranes with the permeance of inorganic membranes.

The membranes were tested in a continuous flow system. Helium was chosen as a surrogate for H₂ in these tests, and an Ar sweep gas was used. Permeances were measured for CO₂ and He over a range of pressures at room temperature and over a range of temperatures, and selectivities were calculated over those ranges. Mixed gas tests were also run at room temperature in which real separation factors were measured. Early results in these studies appear extremely promising. Selectivity for CO₂ has been observed in association with permeance as high as $1.8 \times 10^{-3} \text{ cm}^3 \text{ Torr}^{-1} \text{ s}^{-1} \text{ cm}^{-2}$.

INTRODUCTION

It has been suggested that the Integrated Gasification Combined Cycle (IGCC) will one day account for the majority of energy production in the United States [1-2]. The process, which includes gasification of coal to produce CO and H₂, pollutant abatement, and combustion of the resulting clean process gas to produce electricity, offers great potential for the clean, efficient production of energy from coal. Substantial efforts are currently underway to develop the necessary technologies for removal of pollutants, such as sulfur, from the process gas [3]. As this technology matures, it will be possible to concurrently develop CO₂ removal techniques that readily integrate with it, laying the groundwork for energy production from coal that is not only clean and efficient but also significantly reduces greenhouse gas emission.

Membranes are one of a number of technologies being examined for CO₂ removal in IGCC applications. Membranes, though well established in liquid filtration applications, are only beginning to see widespread implementation in more difficult gas separations. The natural gas industry has been particularly quick to adopt membranes for CO₂ removal in gas sweetening applications. The major reason is the ease with which membrane modules can be deployed to remote locations where it would be difficult to construct an amine scrubbing system [4].

The success of natural gas sweetening membranes can be taken as validation of the industrial applicability of membrane research, but membranes developed for that application do not represent solutions to the problem of CO₂ separation in others. The molecular characteristics of CO₂ make it much easier to separate from CH₄ than from H₂ and CO as would be necessary in purification of IGCC process gas. Significant research and development is required to produce membranes capable of conducting these more difficult separations.

One possible means of developing such membranes involves the modification of an inorganic substrate, such as the innately stable and permeable alumina, with organic groups to increase selectivity. The grafting of organosilanes onto the inorganic surface is a well-studied method. Attachment is accomplished when halogen atoms on the silane molecule interact with hydroxyl groups on the inorganic surface, eliminating HCl and forming a covalent attachment. As many as three such interactions can occur per silane molecule, anchoring it to the surface. Since the silane molecule can also contain nearly any organic group, this method provides an extremely flexible tool for surface modification [5]. Using this method, research has begun to develop membranes useful in CO₂ abatement in IGCC processes.

EXPERIMENTAL

Fabrication

Membranes were prepared by modifying a 2 to 5 μm layer of γ-alumina supported on the inner surface of 2.5 cm cylindrical segments of 1 cm diameter α-alumina tubes

purchased from Pall Corporation. The nominal pore diameter of the active γ -alumina layer was 5 nm. In FTIR and XPS studies, identically modified γ -alumina Whatman Anodiscs with a 13 mm diameter and nominal pore size of 5 nm were used as a surrogate for these membranes.

The initial silation procedure followed the technology of McCarley and Way in their silation study of γ -alumina with octadecyltrichlorosilane [6]. To facilitate eventual sealing in the performance system, each tube was covered at the ends with Duncan GL 612 glaze and fired at 800°C for 6h, and the process was repeated. The discs were heated in the same fashion, but no glaze was applied. The cooled tubes and discs were placed in a 500 ml round-bottomed flask with approximately 75 ml of 30 percent H₂O₂ (Fisher, 31.1%) and refluxed for 30 min. Afterward, the tubes were rinsed in deionized water and returned to the heating apparatus to reflux in 75 ml of deionized water for 30 min. These steps were designed to clean and hydroxylate the alumina surface before silation. After completion of this procedure, the tubes and discs were dried at 80°C for 1h in air. In order to isolate the role of pretreatment, modifications were made in the procedure including removal of the prefiring step, hydroxylation in deionized water instead of H₂O₂, and drying at 150 rather than 80°C.

Silation was initially conducted by placing 120 ml of room temperature anhydrous toluene (Aldrich, 99.8%) in a 250 ml Erlenmeyer flask. A mixture of 5 ml of the trichlorosilane of interest (Gelest, >95%) and 10 ml of toluene was added. The graduated cylinder was then rinsed with an additional 10 ml of toluene and this too was placed in the flask. A magnetic stirrer was added, and mixing was begun at a slow speed. After a few seconds, the tube or disc was added and a stopper inserted to seal the flask. The reaction was allowed to continue for 6h. When it was complete, the tube or disc was removed, rinsed with additional toluene, and allowed to soak in 400 ml of toluene for 24 h. The silation procedure was conducted entirely in a glove box under dry nitrogen. The siled tubes and discs were then dried in a lab oven at 80°C in ambient air for 24 h. The silation procedure was later modified by substituting anhydrous toluene at 0°C. The reaction mixture was then treated as usual and allowed to come to room temperature.

FTIR

A Thermo-Nicolet Nexus 670 Fourier Transform Infrared (FTIR) spectrometer was used to conduct transmission analysis of Anodisc samples in order to confirm the presence of silanes. Samples were examined at room temperature under ambient pressures of N₂ using a liquid N₂ cooled MCT detector. The Anodiscs were affixed to index cards after pretreatment and held in the beam at an angle approximately 30 degrees from the perpendicular to limit fringing effects. Samples were placed in the chamber under dry N₂ and allowed to equilibrate for one hour. Two hundred scans were taken for each sample at a resolution of 4 cm⁻¹.

XPS

X-ray photoelectric spectroscopy (XPS) measurements were performed on a PHI 5600ci spectrometer with a monochromatic Al X-ray source. Anodisc samples were examined with an analyzer pass energy of 58.7 eV. Sputter profiling to a depth of 1000 Å was performed using 3 kV Argon ions at a sputter rate of approximately 235 Å/min.

Performance Testing

Performance testing was conducted in the flow system shown in Figure 1. The membrane tubes were mounted in the system using high-temperature Teflon Swagelok fittings. A flow of 500 ml/min of He, CO₂ or an equal mixture of the two was passed along the tube interior while 500 ml/min of Ar sweep gas flowed in the annular section surrounding the membrane exterior. Pressure was varied 0 to 350 kPa on each side of the membrane using a needle valve downstream. A clamshell type tube furnace (Schmidt Model 1) enclosed the membrane assembly. Temperature was controlled between ambient and 150°C by a Love Controls Series 2600 temperature controller. Both the permeate and retentate were analyzed using an HP 5890 gas chromatograph with twin TCD detectors and Alltech Hayeseq D 100/120 packed columns.

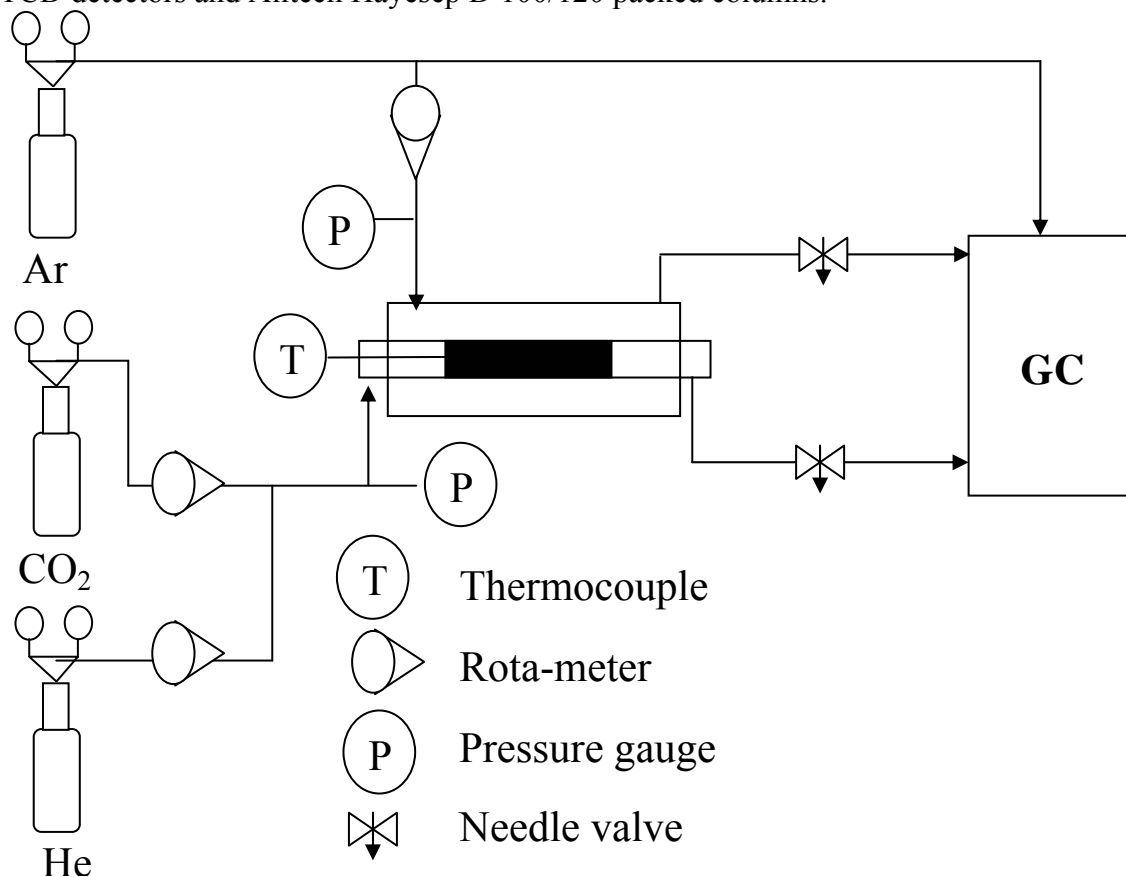

Figure 1. Diagram of system designed for measuring the permeance of experimental membranes.

RESULTS AND DISCUSSION

FTIR

Transmission FTIR, while unable to give quantitative measures of functional density due to minute variation in the thickness of the Anodisc supports, can elucidate the state of the silane in the discs and confirm that reaction has occurred with the surface. Figure 2 shows four spectra representing a disc silylated by the standard technique with *n*-butyltrichlorosilane alongside discs in which one of the three main pretreatment parameters, firing, drying temperature, or hydroxylation technique, was varied. All spectra showed stretches between 2800 and 3000 cm^{-1} and between 1300 and 1700 cm^{-1} as well as a single peak at approximately 2325 cm^{-1} . Other researchers have assigned the 2800-3000 cm^{-1} stretches to the hindered motion of bound alkylsilanes coupled to the alumina surface [6-8].

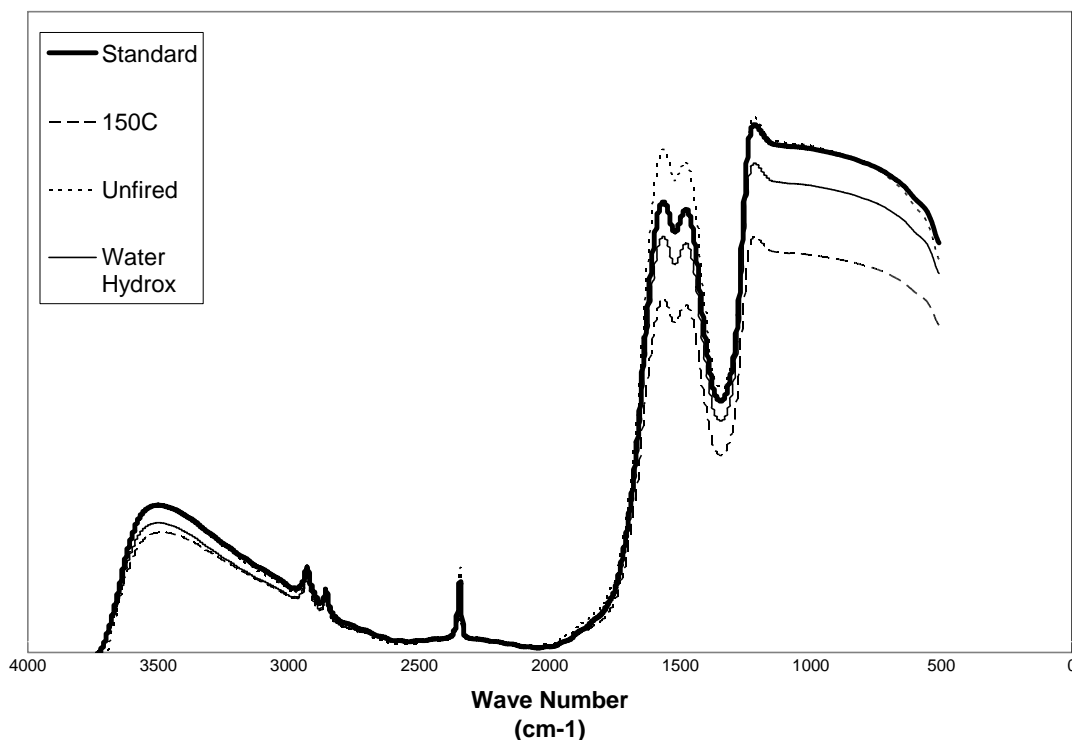

Figure 2. Comparison of FTIR spectra for membranes prepared with varying pretreatments.

While not conclusive, it is interesting to note that the peak intensity observed in the spectra follow the expected trends of silane coverage. Minor differences in absorbance were observed with the unfired sample giving the strongest signal followed by the standard, the water hydroxylated sample, and the sample dried at 150°C after silylation. The lower absorbance of the fired samples suggest that firing irreversibly removes a portion of the surface hydroxyl groups intended to act as silane attachment sites. From the lower absorbance of the water hydroxylated sample over those hydroxylated in H_2O_2 , it can be suggested that water, as expected, is a less efficient hydroxylation agent than H_2O_2 . The lower signal obtained from the sample dried at elevated temperature could be

taken as evidence that some silane is removed from the surface, probably via oxidation, during high-temperature drying. This result has both negative and positive implications for the stability of the siled membranes. While it is reasonable to view the removal of a portion of the silane as a setback, it is fortuitous that a large portion of the silane was stable at elevated temperatures in an oxidizing environment, conditions under which the membrane was not designed to operate.

XPS

Through sputter profiling, XPS can determine the elemental composition of a sample to a depth of approximately 1000 Å. Unsiled samples were determined to have no significant Si impurity, so it was possible to examine the degree of silation by determination of the elemental fraction of Si. Sputter profiles of discs siled with n-butyltrichlorosilane are shown in Figure 3. One possible explanation of this observation is that at room temperature the silane undergoes a polymerization reaction which is catalyzed by the alumina surface resulting in a layer of silane on the surface that blocks the pores and prevents silation of the internal pore surface area. Reducing the temperature would slow the kinetics of the polymerization reaction but would do little to limit the much more favorable reaction with surface hydroxyl groups [9]. It is then reasonable to suggest that the cold silation procedure produces a silane layer over a larger portion of the internal surface of the membrane leading to superior separation properties.

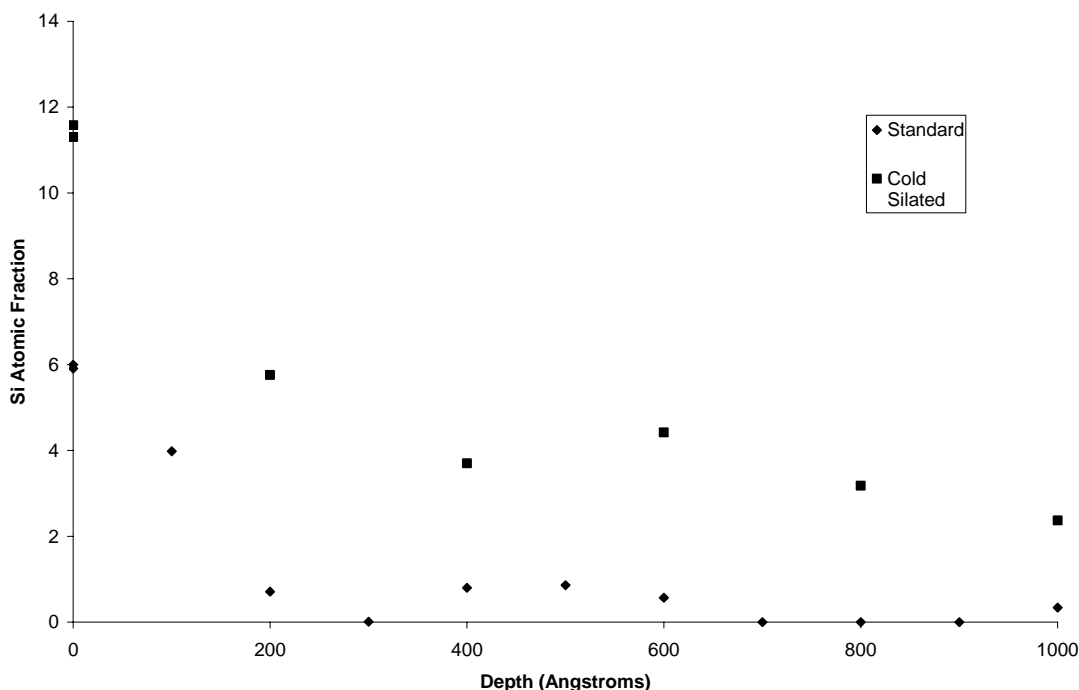

Figure 3. Comparison of XPS sputter profiling for room temperature and cold siled membranes.

Performance Testing

The unmodified γ -alumina support, having a nominal pore diameter of 5 nm, may be assumed to display Knudsen diffusion. The assumption is confirmed by measurements which show permeance to be 1.87×10^{-2} and 7.69×10^{-2} scc/s/Torr/cm² for CO₂ and He, respectively. Those permeances are within the expected range for this type of diffusion. Further evidence of Knudsen diffusion comes from the observed selectivity of 4.1. Theoretical Knudsen selectivity can be calculated as the ratio of the square roots of the molecular weights of the diffusing molecules, 4.7 for He and CO₂. The findings are in excellent agreement with those of McCarley and Way [6] who observed permeances in the range of 3.0×10^{-2} to 1.2×10^{-1} scc/s/Torr/cm² for a variety of gases passing through the same unmodified support.

The contribution of Knudsen diffusion to mass transfer across the membranes appears to diminish with the addition of the silane group. The initial He selectivity, Figure 4, of 4.1 is reduced to 3.3 by silation with n-butyltrichlorosilane and still further to approximately 2 for larger alkyl silanes. This observation could be explained by the gradual plugging of pores with polymer-like clusters of silane molecules which would foster solution diffusion and reduce the contribution of Knudsen diffusion.

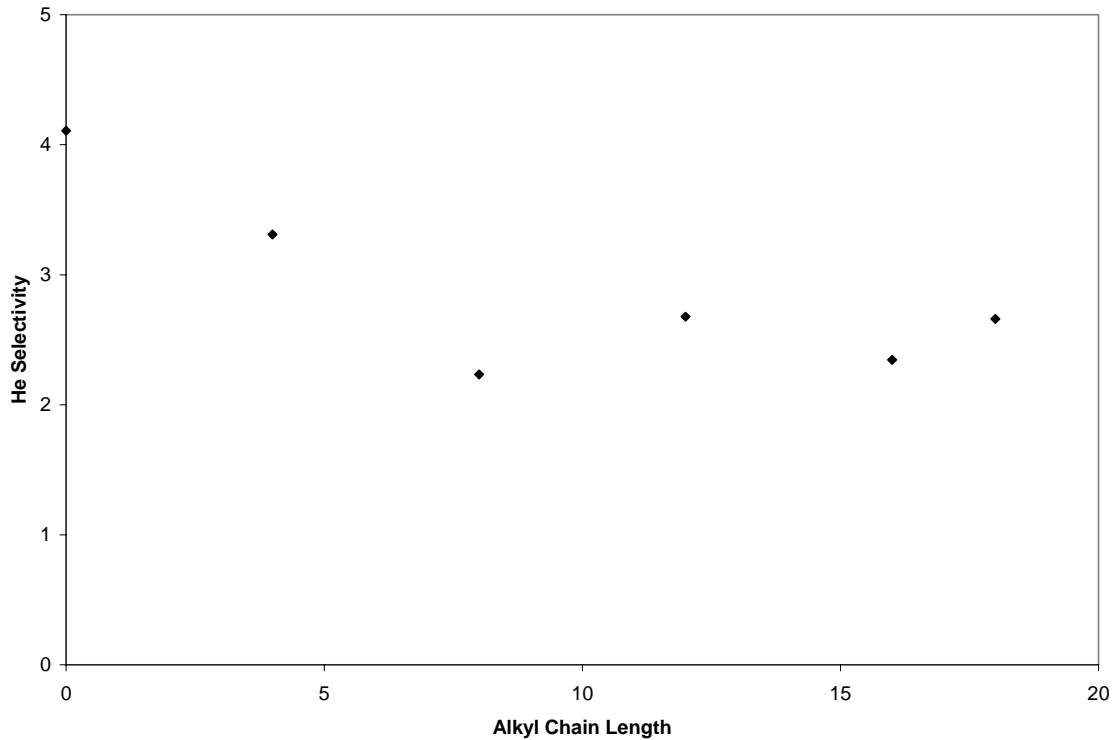

Figure 4. Dependence of He/CO₂ selectivity on chain length of alkyldichlorosilane bound to the membrane.

The trend in permeance (Figure 5) is interesting because of what is not observed. If one assumes steady pore size reduction by addition of longer alkyl chain, it would be expected that permeance would decrease until total pore plugging resulted in the degree of permeance normally observed in solution diffusion. Instead reduction in permeance is

observed until the carbon chain length reaches 12 and is stable thereafter. In Figure 5, it should be noted that the modified fabrication technique, corresponding to deeper silane penetration (Figure 3), permits a higher permeance as compared to the original technique.

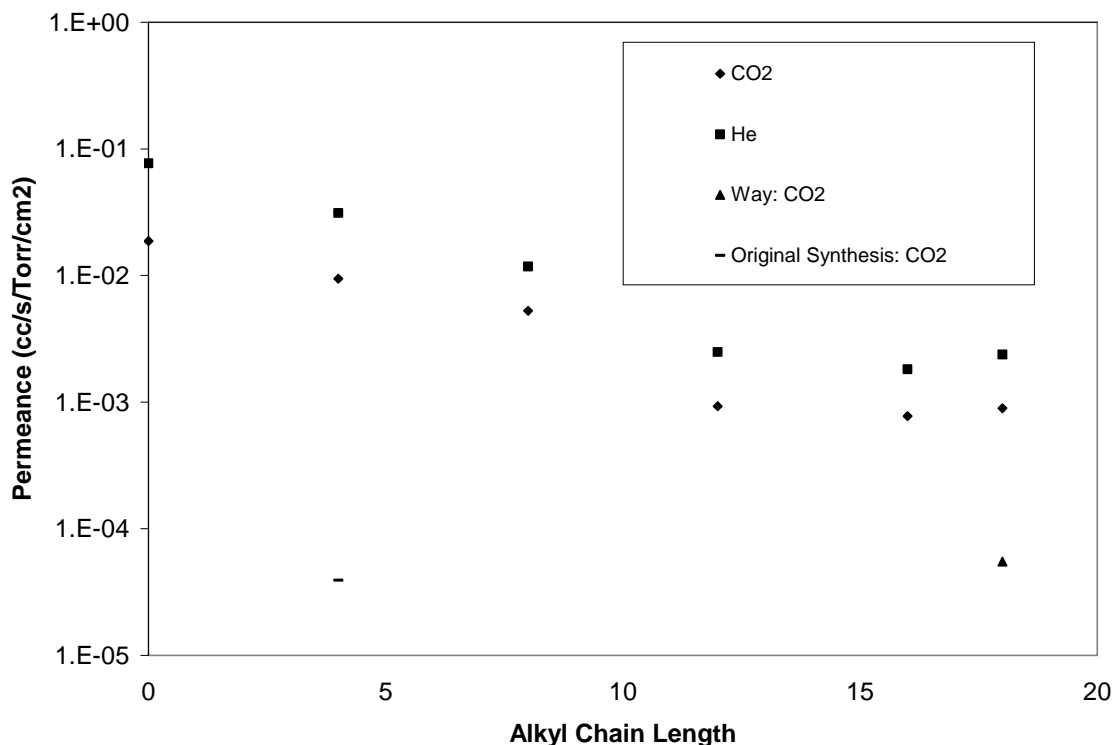

Figure 5. Dependence of CO₂ permeance on alkylsilane chain length and comparison to literature.

McCarley and Way reported the permeance of CO₂ through an identical support siled with octadecyltrichlorosilane to be 5.5×10^{-5} scc/s/Torr/cm². This value is two orders of magnitude below that observed for an octadecyltrichlorosilane membrane produced by the modified synthesis procedure, but is very similar to the 3.9×10^{-5} scc/s/Torr/cm² observed for a membrane produced by silation with n-butyltrichlorosilane using the original procedure based on their work. XPS (Figure 3) showed a greater degree of silation in the membrane produced by the modified procedure. It is suggested that regardless of chain length in membranes produced by McCarley and Way's original procedure, the majority of the silane is deposited in a thin layer around the pore openings causing more pores to be plugged and reducing permeance.

To facilitate CO₂ selectivity, membranes were prepared by silation of the supports with 2-acetoxyethyltrichlorosilane (aceto) and 2-(carbomethoxy)ethyltrichlorosilane (carbo) which were thought likely to have strong molecular interaction with CO₂. The CO₂ and He permeances of the aceto membrane did not change significantly with changes in mean pressure indicating a limited contribution of the solution diffusion mechanism. The carbo membrane showed a similar pressure independence in the permeance of He, but CO₂ permeance increased with increasing mean pressure suggesting the possible importance of solution diffusion in that membrane.

Both He and CO₂ permeances for the aceto membrane are on the order of 10⁻³ scc/s/Torr/cm² at 150°C (Figure 6). Permeances for the carbo membrane are an order of magnitude lower (Figure 7) which could be interpreted as further evidence of the prevalence of the slower solution diffusion mechanism in CO₂ transport for this membrane.

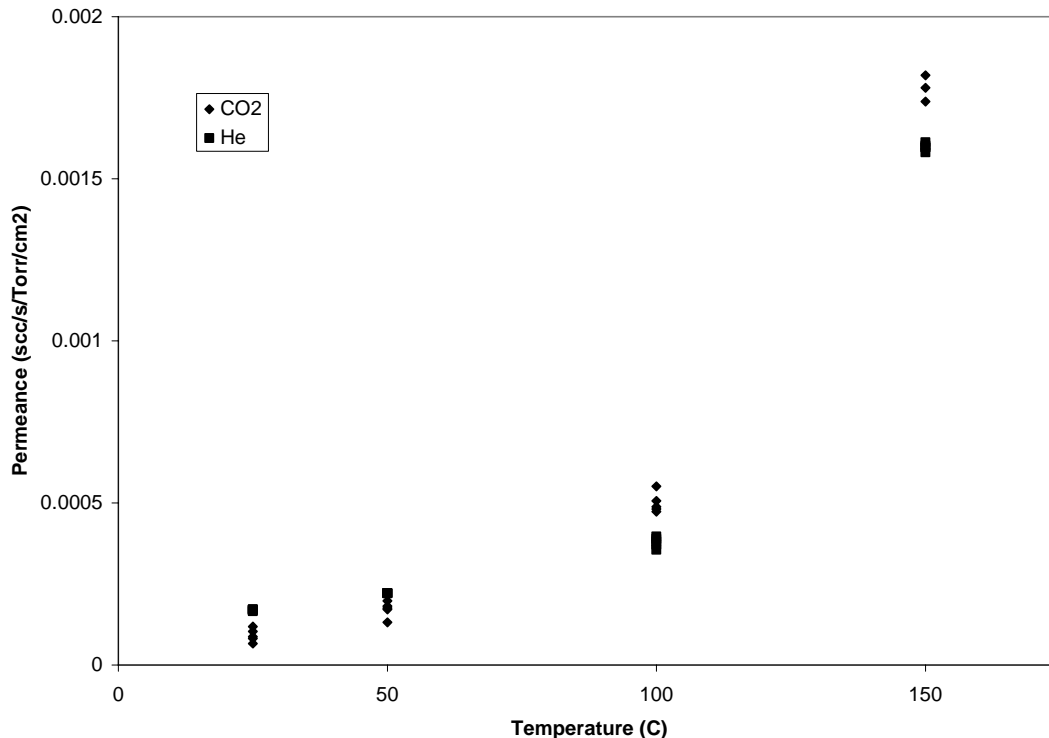

Figure 6. Temperature dependence of CO₂ permeance for 2-acetoxyethyltrichlorosilated membrane.

The temperature trends visible in Figures 6 and 7 are of particular interest. Not only do both membranes show marked increases in permeance as the temperature increase, but the selectivity for CO₂ initially rises in both cases before diminishing at the final temperature of 150°C (Figures 8 and 9).

Simultaneous increases in both selectivity for a heavier molecule and permeance are indicative of only two transport mechanisms. Activated transport, in which a reaction occurs forming an intermediate which is rapidly transported across the membrane usually through solution diffusion, is one possibility. Since any possible intermediate formed on reaction between the silane and CO₂ would be large and consequently less mobile than He, it seems unlikely that activated diffusion is the source of the membrane behavior. Surface facilitated diffusion, which results from the rapid adsorption and desorption of molecules on a pore surface where one molecule is significantly higher in coverage, is a more reasonable hypothesis. The presence of 2-acetoxyethyl- or 2-(carbomethoxy)ethyl-groups on the pore surface could facilitate adsorption of CO₂ at the expense of He. The rise in permeance and selectivity is likely the result of the necessary reversibility of the adsorption in such a process. At room temperature, CO₂ could tend to absorb

irreversibly, thus blocking adsorption sites and not contributing to diffusion. As the temperature rises, residence time on the surface would decrease, and the surface facilitated mechanism could take over resulting in the observed behavior.

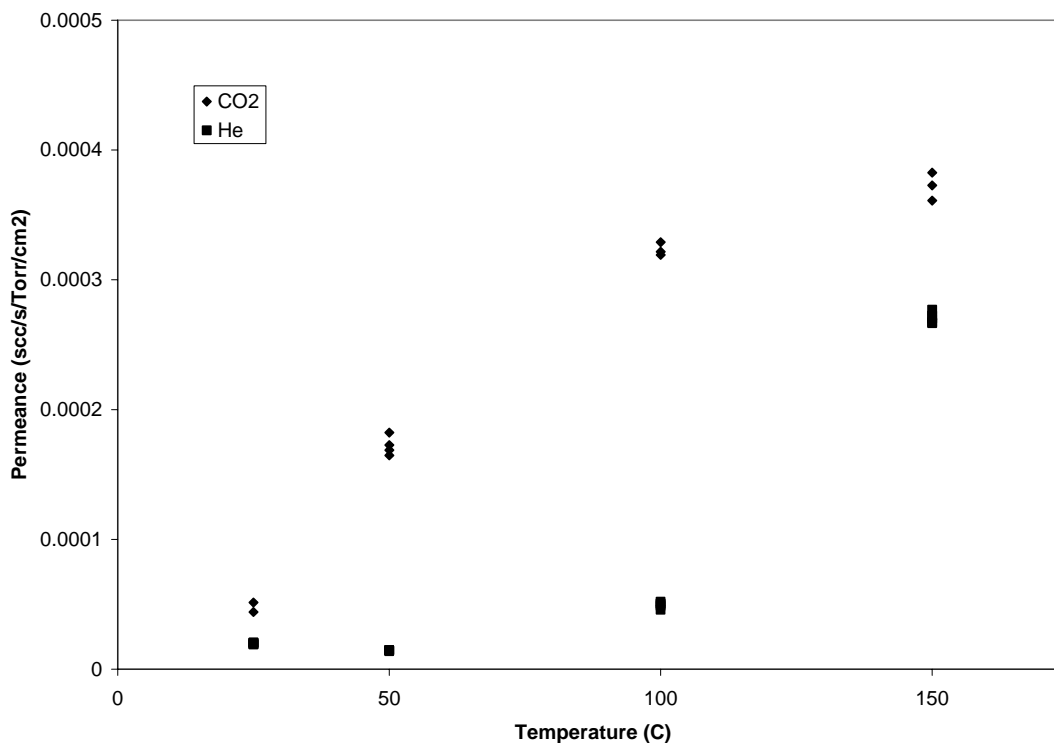

Figure 7. Temperature dependence of CO₂ permeance for 2-(carbomethoxy)ethyltrichlorosilated membrane.

CONCLUSION

The modification of an inorganic support with trichlorosilanes, though long known in literature [10-12], is only now being fully explored as a starting point for the development of CO₂ selective membranes potentially useful in IGCC processes. More interesting than the synthesis method itself is the addition of silane groups to the support while maintaining high permeance through the use of reduced temperature silation. This technique has allowed the development of high permeance membranes which show selectivity for CO₂ over He. As yet, the selectivity is not commercially significant, but research efforts are currently focused on improving synthesis techniques and locating new organosilanes with functionalities showing superior molecular affinity for CO₂ in order to improve it.

Evidence is given for the prevalence of a surface facilitated transport mechanism in the new membranes. Permeance trends with temperature and pressure are consistent with that hypothesis, but more research will be required. A high resolution spectroscopic technique will be useful in elucidating the transport mechanism for these new CO₂ selective membranes.

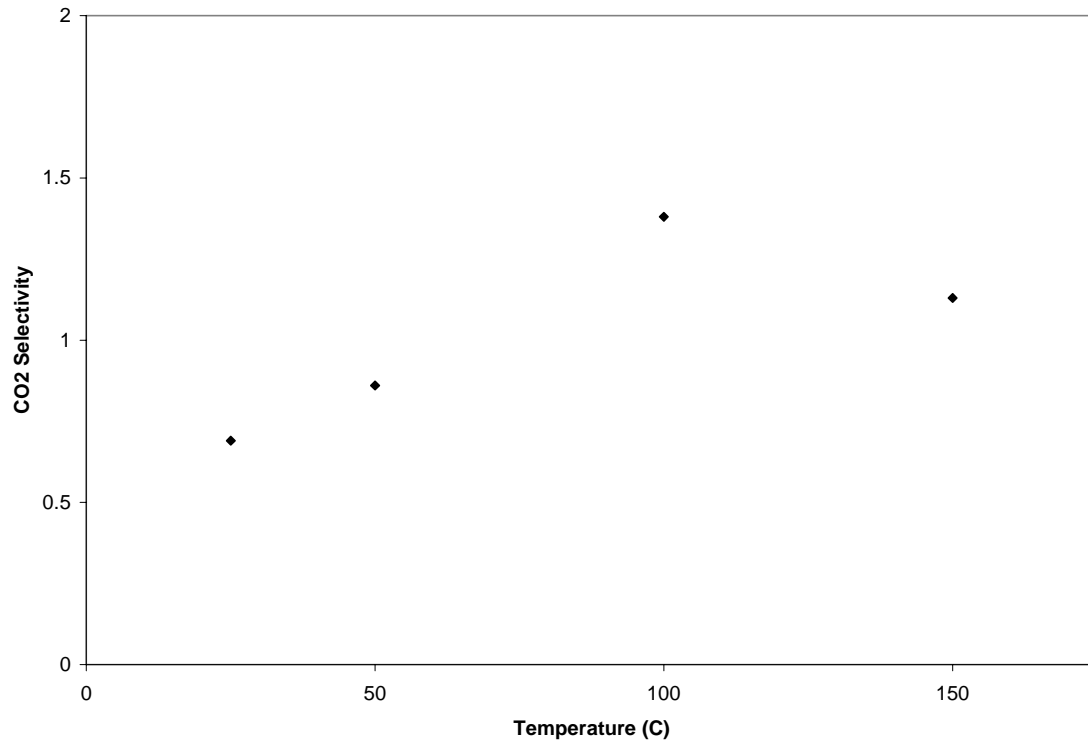

Figure 8. Temperature dependence of CO₂/He selectivity for aceto membrane.

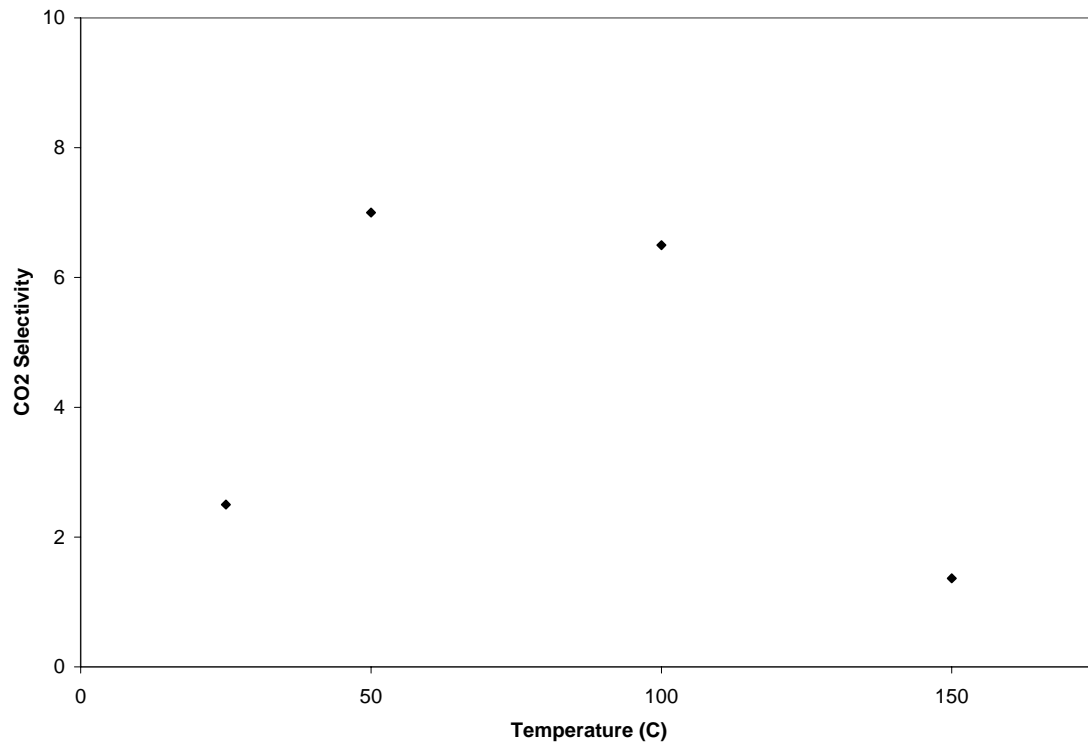

Figure 9. Temperature dependence of CO₂/He selectivity for carbo membrane.

ACKNOWLEDGMENTS

The authors wish to thank John Baltrus for instruction and collaboration in our XPS studies, Angela Goodman and Lisa Campus for instruction and collaboration in our FTIR studies, Bryan Morreale, Mike Ciocco, and the Parsens HMT crew for excellent work with the performance studies. This work was funded entirely by Office of Fossil Energy, U.S. Department of Energy.

DISCLAIMER

Reference in this report to any specific commercial process, product or service is to facilitate understanding and does not necessarily imply its endorsement or favoring by the United States Department of Energy.

REFERENCES

1. IEA Coal Research Report, "CO₂ Reduction-Prospect for Coal," by I. M. Smith, December 1999.
2. D. Jansen, A.B.J. Oudhuis, and H.M. van Veen, *Energy Convers. Mgmt.* 33 (1992) 365.
3. IEA Coal Research Report, "Hot gas cleanup of sulphur, nitrogen, minor and trace elements" by Stuart C. Mitchell, December 1998.
4. W. Echt, Proceedings of 2002 Laurance Reid Gas Conditioning Conference, (2002) 1.
5. G. Witucki, *J. Coatings Tech.* 65 (1993) 57.
6. K. McCarley, *J. Way*, 25 (2001) 195.
7. C. Leger, H. Lira, R. Paterson, *J. Membrane Sci.*, 120 (1996) 187.
8. L. Bellamy, *The Infrared Spectra of Complex Molecules*, Chapman and Hall, New York, 1980.
9. R. Maoz, J. Sagiv, D. Degenhardt, H. Moehwald, and P. Quint, *Supramolecular Sci.* 2 (1995) 9.
10. J. R. Miller, W.J. Koros, *Sep. Sci. Technol.* 25 (1990) 1257.
11. J.R. Miller, Transport Properties of Native and Chemically Modified Gamma-Alumina Membranes, Department of Chemical Engineering, University of Texas at Austin, Austin, TX, 1992.
12. C. Leger, H.D.L. Lira, R. Paterson, *J. Membr. Sci.* 120 (1996) 187.