



U.S. DEPARTMENT OF
ENERGY

PNNL-17949

Prepared for the U.S. Department of Energy
Under Contract DE-AC05-76RL01830

Analysis of the Effects of Compositional and Configurational Assumptions on Product Costs for the Thermochemical Conversion of Lignocellulosic Biomass to Mixed Alcohols – FY 2007 Progress Report

Y Zhu
MA Gerber
SB Jones
DJ Stevens

December 2008



Pacific Northwest
NATIONAL LABORATORY

DISCLAIMER

This report was prepared as an account of work sponsored by an agency of the United States Government. Neither the United States Government nor any agency thereof, nor Battelle Memorial Institute, nor any of their employees, makes **any warranty, express or implied, or assumes any legal liability or responsibility for the accuracy, completeness, or usefulness of any information, apparatus, product, or process disclosed, or represents that its use would not infringe privately owned rights.** Reference herein to any specific commercial product, process, or service by trade name, trademark, manufacturer, or otherwise does not necessarily constitute or imply its endorsement, recommendation, or favoring by the United States Government or any agency thereof, or Battelle Memorial Institute. The views and opinions of authors expressed herein do not necessarily state or reflect those of the United States Government or any agency thereof.

PACIFIC NORTHWEST NATIONAL LABORATORY

operated by

BATTELLE

for the

UNITED STATES DEPARTMENT OF ENERGY

under Contract DE-AC05-76RL01830

Printed in the United States of America

Available to DOE and DOE contractors from the
Office of Scientific and Technical Information,
P.O. Box 62, Oak Ridge, TN 37831-0062;
ph: (865) 576-8401
fax: (865) 576-5728
email: reports@adonis.osti.gov

Available to the public from the National Technical Information Service,
U.S. Department of Commerce, 5285 Port Royal Rd., Springfield, VA 22161
ph: (800) 553-6847
fax: (703) 605-6900
email: orders@ntis.fedworld.gov
online ordering: <http://www.ntis.gov/ordering.htm>



This document was printed on recycled paper.

(9/2003)

Analysis of the Effects of Compositional and Configurational Assumptions on Product Costs for the Thermochemical Conversion of Lignocellulosic Biomass to Mixed Alcohols – FY 2007 Progress Report

Y Zhu
MA Gerber
SB Jones
DJ Stevens

December 2008

Prepared for
the U.S. Department of Energy
under Contract DE-AC05-76RL01830

Pacific Northwest National Laboratory
Richland, Washington 99352

Executive Summary

The purpose of this study was to examine alternative biomass-to-ethanol conversion process assumptions and configuration options to determine their relative effects on overall process economics. A process-flow-sheet computer model was used to determine the heat and material balance for each configuration that was studied. The heat and material balance was then input to a costing spreadsheet to determine the impact on the ethanol selling price. By examining a number of operational and configuration alternatives and comparing the results to the base flow sheet, alternatives having the greatest impact the performance and cost of the overall system were identified and used to make decisions on research priorities.

The process flow sheet was divided into the following four sections:

1. Gasification (includes feed preparation, the gasifier reactor, and gas particulate removal)
2. Gas purification and conditioning (includes tar cracking, acid gas removal, reforming, and compression)
3. Mixed alcohol synthesis and product separation and purification
4. Steam cycle and power generation.

CHEMCAD process modeling software was used to model the process configurations for an integrated biomass-to-mixed-alcohol conversion process based on two gasifier configurations:

1. An indirectly heated gasifier
2. A directly heated (oxygen-blown) pressurized gasifier.

The gasifier capacity was assumed to be 2000 dry tonnes per day of wood chips for all cases. Both gasifier models used similar processing assumptions and unit operation configurations as those used by Aden et al. (2005) in their milestone completion report and Spath et al. (2005) in their design report. Excel spreadsheet models were used to calculate the total equipment and operating costs using similar economic assumptions as used by Spath et al. (2005).

Several cases were examined for integrated processes using each gasifier configuration. Some of these cases examined process assumptions such as the raw gas composition and operating pressure, while others examined the effects of selected changes to the processes. Also, some of the cases were specific to one of the gasifier configurations while others were evaluated for both configurations. The motivation for selecting these cases and the implications of model limitations on interpretation of the results are discussed in the report.

Seven cases were considered for the mixed-alcohol synthesis plant with synthesis gas (syngas) produced by an indirectly heated gasifier.

In the *Base Case*, the gasifier syngas composition was based on correlations developed by Spath et al. (2005) for an indirectly heated gasifier. The balance of plant processing assumptions and unit operation configurations were similar to those used by Spath et al. (2005) and Aden et al. (2005).

Two alternative cases, *Case A1* and *Case A2*, were chosen to study the effects of syngas composition and gasifier pressure.

- *Case A1*. The gasifier raw syngas composition had a H₂:CO ratio close to 2:1 vs. ~0.5 for the base case.
- *Case A2*. The gasification pressure was increased to 147 psi (10 atm) compared to 23 psig for the *Base Case*. Because the gasifier model does not include a pressure factor, the syngas composition was assumed to be the same as that predicted at atmospheric pressure.

Two alternative cases, *Case A3* and *Case A4*, were chosen to study the effects of changes to reformer/shift reactor configurations.

- *Case A3*: The steam reformer was replaced by a simple shift reactor. Methane and ethane were assumed to be inert in the synthesis step. The total syngas pressure was increased to maintain the same H₂ and CO partial pressures as in the *Base Case*.
- *Case A4*. The same assumptions as in *Case A3* applied, except that the total syngas pressure was unchanged from the *Base Case*.

Two alternative cases, *Case A5* and *Case A6*, were chosen to study the effects of tar production.

- *Case A5*. The tar production rate was double that of the *Base Case*.
- *Case A6*. The tar production rate was half that of the *Base Case*.

Seven cases were also considered for the mixed-alcohol synthesis plant with synthesis gas (syngas) produced by a directly heated gasifier.

In the *Base Case*, the raw gas composition was from correlations developed by Eggeman (2005) based on experimental data reported in Evans et al. (1988) using the Gas Technology Institute's 12 tons per day process research unit.

Two alternative cases, *Case B1* and *Case B2*, were chosen to study the effects of gasifier pressure and syngas composition.

- *Case B1*. The gasification pressure was decreased to 20 psig, compared to 330 psig for the *Base Case*. The syngas is assumed to have the same composition as that predicted at higher pressure.
- *Case B2*. The gasification pressure was changed to 20 psig. The syngas composition was adjusted by extrapolating the gasifier correlations to 20 psig.

Two alternative cases, *Case B3* and *Case B4*, were chosen to study the effects of changes to reformer/shift configurations.

- *Case B3*. The steam reformer was replaced by a simple shift reactor. Methane and ethane were assumed to be inert in the synthesis step. The total syngas pressure was increased to maintain the same H₂ and CO partial pressures as in the *Base Case*.
- *Case B4*. The same assumptions as in *Case A3* apply, except that the total syngas pressure was not changed from the *Base Case*.

Two alternative cases, *Case B.5* and *Case B.6*, were chosen to study the effects of tar production.

- *Case B5*. The tar production rate was double that of the *Base Case*.
- *Case B6*. The tar production rate was one-half of that in the *Base Case*.

Simulation results and analysis for the alternative cases evaluated in this study point to the potential importance of operating the gasifier at elevated pressure, and minimizing gasifier products that ultimately lead to decreased production of H₂ and CO in the clean synthesis gas. Specifically, we found that minimizing char production in the gasifiers, the amount of unconverted tar in the tar cracker, and the amount of unconverted methane leaving the methane reformer led to higher quantities of H₂ and CO that could be converted into mixed alcohols, thereby decreasing unit production costs. Generally, we found that relatively small increases in mixed alcohol production efficiency more than offset the capital and annual operating costs required to achieve these improvements.

We also found that consideration should also be given to operating the gasifier in a manner that best matches the H₂:CO ratio requirements of the alcohol synthesis reactor without requiring significant forward or reverse water-gas shift (WGS) in the methane reforming/WGS reactor.

Acronyms and Abbreviations

°C	degrees Celsius
°F	degrees Fahrenheit
\$mm/yr	million dollars per year
ASU	air separation unit
atm	atmospheres
BTU	British Thermal Units
C ₂ H ₂	acetylene
C ₂ H ₄	ethylene
C ₂ H ₆	ethane
CEPCI	Chemical Engineering Plant Cost Index
CH ₄	methane
CO	carbon monoxide
CO ₂	carbon dioxide
COS	carbonyl sulfide
CS ₂	carbon disulfide
EIA	Energy Information Administration
EtOH	ethanol
FT	Fischer-Tropsch
G&A	general and administrative (costs)
gal	gallon(s)
H ₂	hydrogen
H ₂ O	water
H ₂ S	hydrogen sulfide
HP	high pressure
lb	pound(s)
LP	low pressure
N ₂	nitrogen

NH ₃	ammonia
O ₂	oxygen
psia	pounds per square inch absolute
psig	pounds per square inch gage
ROI	return on investment
scf	standard cubic feet
syngas	synthesis gas
TPEC	total purchased equipment cost
WGS	water-gas shift
yr	year(s)
ZnO	zinc oxide

Contents

Executive Summary	iii
Acronyms and Abbreviations	vii
1.0 Introduction	1.1
2.0 Process Design Basis and Modeling Approach.....	2.1
2.1 Biomass Gasification Section Model	2.1
2.1.1 Feed Preparation.....	2.2
2.1.2 Gasifier Section.....	2.2
2.1.3 Particulate Removal	2.4
2.1.4 Heat Recovery	2.5
2.2 Gas Purification and Conditioning Model.....	2.5
2.2.1 Tar Removal.....	2.6
2.2.2 Water Scrubber/Acid Gas Removal	2.6
2.2.3 Methane Reforming and Water-Gas Shift Reactor	2.8
2.2.4 CO ₂ Removal and Compression.....	2.8
2.2.5 Heat Recovery	2.8
2.3 Alcohol Synthesis and Product Recovery Model.....	2.9
2.3.1 Alcohol Synthesis Reactor	2.9
2.3.2 Product Gas Recycle	2.11
2.3.3 Liquid Separation and Purification.....	2.12
2.3.4 Methanol Byproduct Recycle.....	2.12
2.4 Steam-Cycle and Power-Generation Model.....	2.12
2.5 Overall Process Modeling and Cost Estimation Methodology	2.14
3.0 Results and Analysis.....	3.1
3.1 Indirectly Heated Gasifier Scenarios.....	3.1
3.1.1 Base Case	3.1
3.1.2 Case A1: Raw Gas Composition with H ₂ :CO Ratio Close to 1.7:1	3.4
3.1.3 Case A2. Gasifier Pressure Increases to 10 Atm.....	3.5
3.1.4 Case A3. Methane/Ethane are not Reformed and Clean Syngas Pressure Changed to Maintain H ₂ /CO Partial Pressures.....	3.7
3.1.5 Case A4. Methane/Ethane is Assumed to be Inert and Clean Syngas Pressure Unchanged.....	3.8
3.1.6 Case A5: Tar Production is Assumed to be Double that of Base Case	3.9
3.1.7 Case A6: Tar Production is Assumed to be Half that of the Base Case	3.10
3.2 Directly Heated Gasifier Scenarios	3.11
3.2.1 Base Case	3.11
3.2.2 Case B1. Gasifier Pressure Decreases and Syngas Compositions are Unchanged...	3.14
3.2.3 Case B2. Gasifier Pressure Decreases and Syngas Compositions are Changed	3.15

3.2.4	Case B3. Methane/Ethane are not Reformed and the Clean Syngas Pressure is Changed.....	3.16
3.2.5	Case B4. Methane/Ethane are not Reformed and Clean Syngas Pressure is Unchanged.....	3.17
3.2.6	Case B5. Tar Production is Assumed to be 1.5 Times that of the Base Case	3.18
3.2.7	Case B6. Tar Production is Assumed to be Half that of the Base Case	3.19
4.0	Conclusions	4.1
5.0	References	5.1
	Appendix A – Equipment Cost Details.....	A.1
	Appendix B – Base Case Flow Sheets and Model Results	B.1

Figures

1.1	Block Flow Diagram for Biomass Gasifier-Based Mixed Alcohol Synthesis Systems.....	1.2
2.1	Feed Preparation and Gasification Section for the Indirectly Heated Gasifier	2.1
2.2	Feed Preparation and Gasification Section for the Directly Heated Pressurized Gasifier	2.2
2.3	Gas Purification and Conditioning Section for Both Gasifier Types.....	2.5
2.4	Lo-Cat Process.....	2.7
2.5	Mixed Alcohol Synthesis and Purification Section	2.9
2.6	Steam and Power Generation Section for the Process Using and Indirectly Heated Gasifier	2.13
2.7	Steam and Power Generation Section for the Process Using a Directly Heated Gasifier.....	2.13

Tables

2.1	Correlation Equation Factors for the Indirectly-Heated Gasifier.....	2.3
2.2	Correlation Equation Factors for the Directly Heated Gasifier	2.4
2.3	Design Performance of Tar Reformer.....	2.6
2.4	Design Assumptions for Mixed Alcohol Synthesis	2.11
2.5	Reaction Stoichiometry and <i>Base-Case</i> Reactant Conversions for Mixed Alcohol Synthesis.....	2.11
2.6	Total Project Investment for the Design Case Standalone Plant.....	2.15
2.7	Economic Assumptions	2.16
3.1	Performance Results for Indirectly Heated Gasifier Based System Models.....	3.2
3.2	Equipment and Capital Cost Results for Indirectly Heated Gasifier Based System Models.....	3.3
3.3	Operating Cost Results for Indirectly Heated Gasifier Based System Models.....	3.3
3.4	Performance Results for Directly Heated Gasifier Based System Models.....	3.12
3.5	Equipment and Capitals Costs for Directly Heated Gasifier Based System Models.....	3.13
3.6	Operating Costs for Directly Heated Gasifier Based System Models	3.13

1.0 Introduction

In 2006, the President of the United States proposed the Advanced Energy Initiative that outlined significant new investments and policies to reduce our dependence on foreign oil supplies by, among other options, changing the way we fuel our vehicles. Implicit in this initiative is a switch from petroleum-based transportation fuels that depend largely on foreign oil supplies to alternative transportation fuels based on other domestic resources. The Energy Independence and Security Act of 2007 (EISA) requires increased biofuel production to be expanded from the original mandate of 7.5 billion gallons by 2012 to a mandate of 36 billion gallons by 2022. The minimum of this requirement must be from advanced biofuels, cellulosic biofuels, and biodiesel fuel.

One domestic resource that has the potential for a significant impact on domestic fuels is biomass. Biomass is a renewable energy resource that can be converted into forms suitable for transportation applications. Currently, these applications are mostly met through the conversion of grain products into fuel-grade ethanol that can be blended with gasoline. Smaller quantities of biomass in the form of vegetable oils have been converted into esters that are suitable for use as diesel fuel. However, while these forms of biomass can supply small but significant quantities of transportation fuels for our domestic needs, other more widely available biomass forms, specifically lignocellulosic biomass forms, also need to be used to have a major impact on domestic supplies of transportation fuel. Ethanol can be produced from lignocellulosic feedstock using two different methods.

1. Directly using advanced bioconversion technologies to convert the cellulose and hemicellulose fractions of the feedstock into ethanol.
2. Indirectly by first gasifying the entire feedstock into a raw gas that then can be further purified and conditioned into a synthesis gas (syngas) (nominally carbon dioxide [CO₂] and hydrogen [H₂]) suitable for alcohol synthesis.

Both methods have technology challenges that will need to be addressed before commercially viable processes are available. To improve the market competitiveness of bioenergy products, research is needed to improve system integration, optimize system design, increase efficiency, and finally lower the cost.

Figure 1.1 shows the simplified process flow for a biomass gasifier-based mixed alcohol synthesis system. The main components are gasification, gas purification and conditioning (tar cracking, acid gas removal, reforming, and compression), mixed alcohol synthesis, and steam cycle/power generation. In this system, wood chips are converted to raw gas in a gasifier. This gas then is sent to a tar reformer and scrubber. The tar and particulate-free gas is sent to a sulfur-removal unit. After gas conditioning and adjustment of the H₂:CO ratio, the resulting syngas is converted into mixed alcohols and then separated into products. Byproducts and unconverted synthesis gas that are unsuitable for recovery, reuse, or sale are used as fuel to produce electricity.

To achieve technical and economic viability for indirect syntheses of alcohol via biomass gasification, two broad issues need to be addressed: 1) creating a syngas that is sufficiently clean for alcohol synthesis and 2) developing a catalyst that can achieve the necessary productivity and selectivity to yield fuel-grade ethanol.

Obtaining a sufficiently clean synthesis gas involves several unit operations, including gasification, tar and particulate elimination, compositional adjustment of the product gas (steam reforming of methane, water-gas shift [WGS], CO₂ removal), and reduction in the concentration of potential catalyst poisons including, but not limited to, low concentrations of sulfur containing species (H₂S, COS, CS₂), chlorides and alkali-containing species. At this time, biomass gasification technologies have been developed to the point of large-scale demonstrations that potentially are applicable to the production of syngas. However, widespread commercialization of large-scale gasifiers or their integration with liquid fuel synthesis technology has not been realized. There are a number of commercial technologies and advanced technologies under development that can impact the other unit operations and, in turn, the overall process economics for producing a suitable syngas. Ethanol synthesis from a H₂/CO syngas has not reached the same point of development as gasification. Currently available catalysts tend to produce a variety of co-products and have relatively low activities when compared to methanol synthesis, which is a commercial process. Several options are available for addressing these issues; however, the economic tradeoffs between product selectivity and productivity are not straight forward.

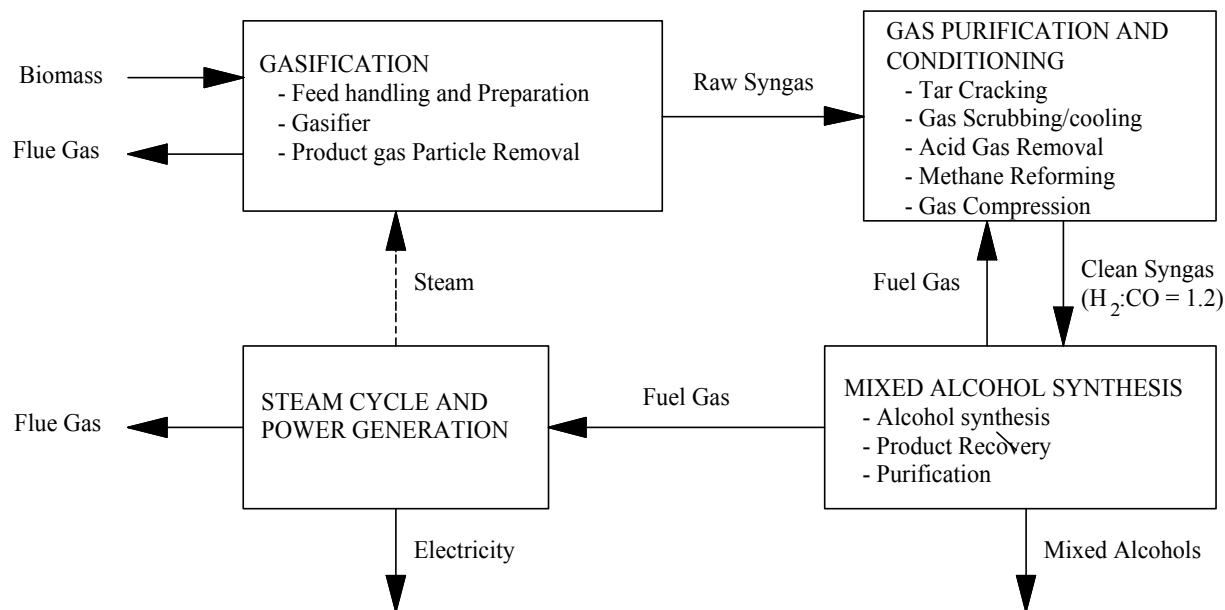

Figure 1.1. Block Flow Diagram for Biomass Gasifier-Based Mixed Alcohol Synthesis Systems

There are a number of operational parameters and process configuration options that affect the cost of producing ethanol from syngas derived from biomass gasification. Among these are the operating pressure of the gasifiers, the efficiency of the process for converting biomass to gas, the method chosen for purifying and adjusting the composition of the gas, the syngas-to-mixed alcohol conversion efficiency, selectivity and productivity, and methods chosen to recover and recycle or otherwise use the nonalcoholic byproducts of syngas conversion. Often changes in individual operational parameters and process configuration options result in changes in operating parameters throughout the integrated process that can affect both equipment and operating costs. A robust computerized process simulation model can be a valuable tool for tracking the effects of these changes and their impact on the costs for the various unit operations. By changing process assumptions of individual unit operations or introducing alternative unit operations and configurations, the simulation model can track process stream changes throughout all unit operations that, in turn, can be used to quantify changes in equipment and operating costs for each

operation. By identifying those changes that have the greatest impact, research can be more effectively directed toward achieving economic viability by 1) focusing research in the key areas and 2) setting processing milestones to measure technical progress.

A number of techno-economic assessments using process design and simulation models have been conducted for biomass gasification to produce a number of products including methanol (Hamelinck and Faaij 2002), Fischer-Tropsch (FT) liquid-based transportation fuels ((Hamelinck et al. 2003), hydrogen (Hamelinck and Faaij 2002; Spath et al. 2005), and ethanol (Aden et al. 2005; Phillips et al. 2007). The latter two studies on ethanol production via biomass gasification/ethanol synthesis focused primarily on the development of process simulation models for base process designs to develop goal-case ethanol product prices. Limited sensitivity analyses of selected technical and economic assumptions on overall product costs also were performed in each study.

The purpose of this study was to examine alternative process assumptions and configuration options to determine the relative effects these have on overall biomass-to-ethanol conversion economics. A process-flow-sheet computer model was used to determine the heat and material balance for each configuration. The heat and material balance then was input to a costing spreadsheet to determine the impact on the ethanol selling price. By examining a number of operational and configurational alternatives to the base flow sheet, those alternatives having the greatest impact the performance and cost of the overall system can be identified and used to make decisions on research priorities.

2.0 Process Design Basis and Modeling Approach

CHEMCAD process modeling software was applied to model process configurations for an integrated process used to produce mixed alcohols from biomass. The processes are based on both an indirectly heated gasifier and a directly heated (oxygen-blown) pressurized gasifier. The gasifier capacity is assumed to be 2000 dry tonne/day wood chips for all cases. Both gasifier models used similar processing assumptions and unit operation configurations as those used by Aden et al. (2005) in their milestone completion report and Spath et al. (2005) in their design report. Excel spreadsheet models were used to calculate the total equipment and operating costs using similar economic assumptions as Phillips et al. (2007), Aden et al. (2005), Hamelinck et al. (2003), and Hamelinck and Faaij (2002). The process flow sheet was divided into four sections so the effects of parameter and configurational changes could be more clearly understood. The systems shown in Figure 1.1 are described in the following sections.

2.1 Biomass Gasification Section Model

The biomass gasification section includes the unit operations related to feed preparation and gasification and product gas particulate removal systems. This is shown in Figure 2.1 for the indirectly heated gasifier and Figure 2.2 for the directly heated gasifier.

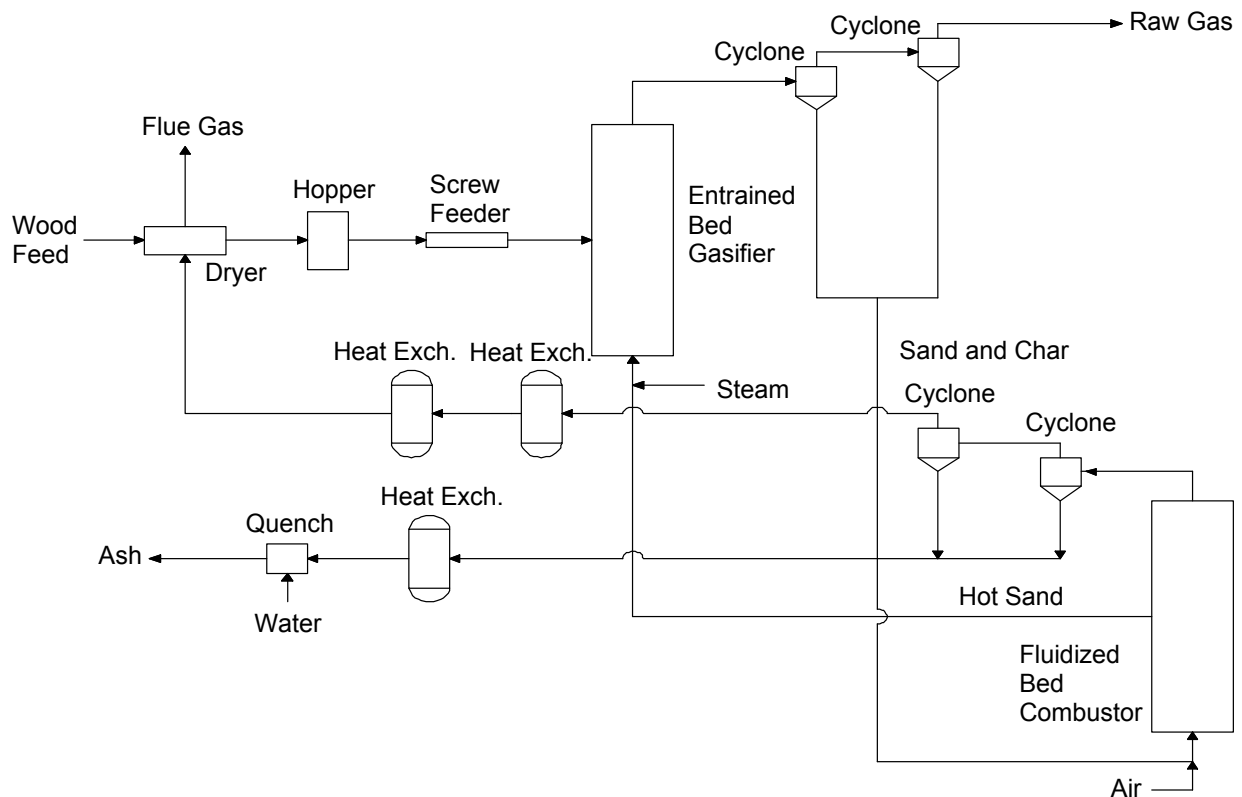

Figure 2.1. Feed Preparation and Gasification Section for the Indirectly Heated Gasifier

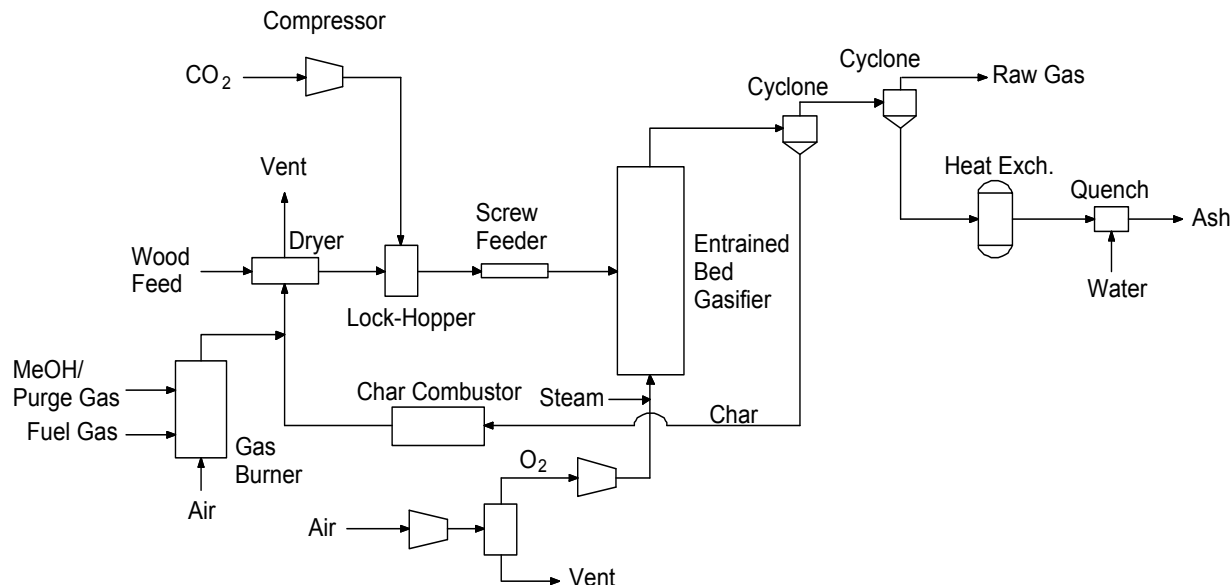

Figure 2.2. Feed Preparation and Gasification Section for the Directly Heated Pressurized Gasifier

2.1.1 Feed Preparation

Biomass is assumed to be received in the form of wood chips with a moisture content of 50 wt% (the wood feed rate to the feed preparation system is 4000 wet tonnes per day). The wood chips are dried in rotary driers. Pre-drying the feedstock before feeding it to the gasifier is necessary to minimize the heat load in the gasifier, thereby reducing char combustion requirements in the indirectly heated gasifier and oxygen requirements in the directly heated gasifier. However, drying wood chips to a moisture content less than 10 to 15% is more energy intensive and requires significantly larger driers (Hamelinck et al. 2003). In this study, a moisture content of 12% is assumed based on a previous study that used wood as the feedstock (Spath et al. 2005).

For the indirectly heated gasifier, the heat from the char combustor hot flue gas is used to produce steam and dry the biomass. The flue gas stack exit temperature is controlled to be greater than the gas dew point (i.e., approximately 300°F). For the oxygen-blown pressurized gasifier, the heat of the flue gas from the char combustor is insufficient to completely dry the wood chips. Therefore, off-gas from the synthesis process is burned to generate additional heat for biomass drying.

2.1.2 Gasifier Section

The indirectly heated gasifier is modeled using the correlation model developed by Spath et al. (2005) based on data from a gasifier developed at Battelle-Columbus Laboratory. A 182-dry-tonne/day demonstration-scale gasifier design was later built by Future Energy Resources Company (FERCO), Atlanta, Georgia, at a Burlington Electric Department wood powered plant in Burlington, Vermont. The syngas from the directly heated (oxygen-blown) pressurized gasifier is predicted using correlations based on the experimental data from an Institute of Gas Technology gasifier (Evans 1988). A 90-tonne/day demonstration plant based on this design was built at the Hawaiian Commercial & Sugar Company's Paia sugar factory in Maui, Hawaii, and operated using bagasse (i.e., the biomass remaining after sugarcane

stalks are crushed to extract their juice) as the feedstock. Both types of gasifiers were modeled using the stoichiometric reactor model in CHEMCAD.

Indirectly Heated Gasifier. The indirectly heated gasifier (Figure 2.1) contains both a gasifier and a separate combustor. Dried wood is fed into a low-pressure indirectly heated gasifier. Steam extracted from the steam cycle is sent to the gasifier at a flow rate of 0.4 lb of steam/lb of bone-dry wood to fluidize the bed and to supply a portion of the heat required for the gasifier. The *Base-Case* gasifier, which is heated by circulating hot olivine particles between the gasifier and the separate combustor (Spath et al. 2005), is operated at 1598°F and 23 psi. A mixture of char formed in the gasifier and olivine particles are removed from the gasifier by separation in a series of cyclone separators, and then sent to the fluidized bed combustor where air is used to burn the char and reheat the olivine. The reheated olivine is then returned to the gasifier. The char combustor temperature is set at 1800°F. The olivine circulating flow rate is 27 lb of olivine/lb of bone-dry wood. Fresh olivine is made up at a rate of 0.1% of the circulating rate to replace material not captured in the cyclone separators. A small amount of MgO is added to the olivine to avoid the formation of a low melting point glass caused by reaction with potassium in the biomass ash. The MgO reacts with the potassium to form a higher melting point material.

For the indirectly-heated gasifier model, the following quadratic function is used to estimate the composition of all of the gas components, tar, and char) (Spath et al. 2005):

$$(A + B*T + C*T^2) \tag{2.1}$$

The correlation equation factors are listed in Table 2.1.

Table 2.1. Correlation Equation Factors for the Indirectly-Heated Gasifier

Gas Components (mol% of dry gas)	A	B	C
H ₂	17.996	-0.026448	1.8930*10 ⁻⁵
CO	133.46	-0.10290	2.8792*10 ⁻⁵
CO ₂	-9.5251	0.037889	-1.4927*10 ⁻⁵
CH ₄	-13.82	0.044179	-1.6167*10 ⁻⁵
C ₂ H ₂	-4.3114	5.4499*10 ⁻³	-1.561*10 ⁻⁶
C ₂ H ₄	-38.258	0.058435	-1.9868*10 ⁻⁵
C ₂ H ₆	11.114	-0.011667	3.064*10 ⁻⁶
Solids components (lb/lb bone dry wood)			
Char	0.75503	-3.0212*10 ⁻⁴	-3.1178*10 ⁻⁸
Tar	0.045494	-1.9759*10 ⁻⁵	

Tar is simulated as 33.3 mole% benzene and 66.7 mole% naphthalene (Spath 2005).

Directly Heated Gasifier. The directly heated gasifier (Figure 2.2) is a pressurized fluidized bed reactor. Steam is used to fluidize the gasifier bed and to provide a portion of the heat. The steam flow rate is 0.2 lb of steam/lb of dry wood with 12 wt% H₂O. The mass flow rate of oxygen is varied to achieve a 1600°F gasifier outlet temperature. The sub-stoichiometric flow rate of oxygen burns a portion of the biomass, thereby supplying heat for the endothermic gasification reactions. Purified oxygen is required rather than air to prevent introducing large quantities of nitrogen into the synthesis gas where it would act as an inert diluent. A pressurized cryogenic air separation unit provides purified oxygen at 99.5% for the

gasifier at 350 psia and 60°F. The dried wood is fed using a lock hopper feeder system in which wood is dropped into a chamber, which is then sealed, and then filled with pressurized CO₂ recovered from the gas purification and conditioning section of the plant. Once the chamber is pressurized, the wood is discharged from the lock hopper and fed to the gasifier. The CO₂ used in the lock hopper is fed at a flow rate of 0.03 lb of CO₂/lb dried wood and compressed to 330 psi. A small amount of MgO is added to the gasifier to react with potassium in the ash to prevent agglomeration in the gasifier bed.

For the directly heated gasifier model, the following function was used to estimate the gas composition, tar (modeled as benzene and naphthalene), and char (Eggeman 2005):

$$(A + B*P + C*T + D*(O_2/Feed C) + E (H_2O/Feed C)) \quad (2.2)$$

The correlation equation factors are listed in Table 2.2.

Table 2.2. Correlation Equation Factors for the Directly Heated Gasifier

Gas Components (lbmol ratio)	A	B	C	D	E
H ₂ /Feed H	-0.3830761	1.894350*10 ⁻⁴	2.666675*10 ⁻⁴	0.1060088	7.88095510 ⁻²
CO/Feed C	-8.130017*10 ⁻²	-3.340050*10 ⁻⁴	2.614482*10 ⁻⁴	0.1495730	-5.26836710 ⁻²
CO ₂ /Feed C	7.157172*10 ⁻²	3.843454*10 ⁻⁴	1.286060*10 ⁻⁵	0.6124545	9.98086810 ⁻²
CH ₄ /Feed C	1.093589*10 ⁻²	1.388446*10 ⁻⁴	8.812765*10 ⁻⁵	-0.2274854	3.42782510 ⁻²
C ₂ H ₄ /Feed C	5.301812*10 ⁻²	-6.740399*10 ⁻⁵	-1.372749*10 ⁻⁵	-9.076286*10 ⁻³	-4.85408210 ⁻³
C ₂ H ₆ /Feed C	0.1029750	-5.440777*10 ⁻⁶	-5.350103*10 ⁻⁵	-3.377091*10 ⁻²	-1.91533910 ⁻³
Benzene/Feed C	4.676833E*10 ⁻²	-1.937444*10 ⁻⁵	-1.270868*10 ⁻⁵	-1.046762*10 ⁻²	-8.45964710 ⁻³
Naphthalene/Feed C	1.827359*10 ⁻²	-2.328921*10 ⁻⁶	-5.951746*10 ⁻⁶	-1.936385*10 ⁻²	-7.678310*10 ⁻⁴
Solids Components (mol% of feed)					
% of Feed N in Char	3.36				
% of Feed S in Char	8.45				
% of Feed O in Char	1.512040	1.582010*10 ⁻⁴	-6.972612*10 ⁻⁴	0.1573581	-0.142091

2.1.3 Particulate Removal

A series of cyclone separators are used to remove particulates and char from the raw gas leaving the gasifier. In the indirectly heated gasifier, the majority of the olivine, char, and ash is separated in the primary gasifier cyclone separator and then sent to the char combustor. The gas from the primary gasifier cyclone is sent to the tar reformer. The char is burned in the char combustor to reheat the olivine. The flue gas from the char combustor is sent to the primary combustor cyclone separator, which separates 99.9% of the olivine which then is returned to the gasifier. Then, the flue gas containing residual fines and ash is sent to a secondary combustor cyclone separator to remove these solids. The residual fines and ash are cooled to 300°F using cooling water to control dust, and the wet solids ultimately are transported to a landfill for disposal.

In the directly heated gasifier, the raw untreated gas from the gasifier is sent to a primary cyclone separator where char is captured and sent to the char combustor. The gas from the primary separator is then sent to a secondary cyclone separator to remove the ash and residual fines. The ash recovered from the secondary separator is cooled to 300°F, and then water is added before the mixture is transported to a landfill for disposal.

2.1.4 Heat Recovery

In the indirectly heated gasifier system, part of the sensible heat of the hot flue gas from the char combustor is recovered by generating high-pressure saturated steam at 1280 psi. This steam is superheated by heat removed from the steam reformer, and then used in a steam turbine to generate electricity. The cooled flue gas is sent to the feed dryer to provide heat for wood drying. For the directly heated gasifier, the heat of flue gas is used only for biomass drying.

2.2 Gas Purification and Conditioning Model

The gas purification and conditioning section shown in Figure 2.3 is similar for both gasifier systems. Hot gas, leaving the cyclone separators from the gasifier section, enters a tar-cracking/reforming unit to eliminate tar from the gas. A portion of the methane and light hydrocarbon gases are reformed in the tar-cracking/reforming unit. The tar-free gas is quenched in a water scrubber to cool the gas and condense water in the gas. The scrubbed syngas is compressed to 450 psig. H₂S in the syngas then is removed with a liquid-phase oxidation process (LO-CAT[®]), followed by ZnO polishing. The treated gas is combined with steam and recycled CO₂ and sent to a methane reformer where methane and other higher hydrocarbon gases are reformed to CO and H₂ in a desired ratio. An amine-based chemical absorption system removes CO₂ from the reformed syngas. The purified synthesis gas is compressed to the desired pressure for mixed alcohol synthesis. High-temperature heat is recovered from the steam reformer process effluent and flue gas. Low-temperature process heat is rejected to the atmosphere and to water-cooled trim exchangers.

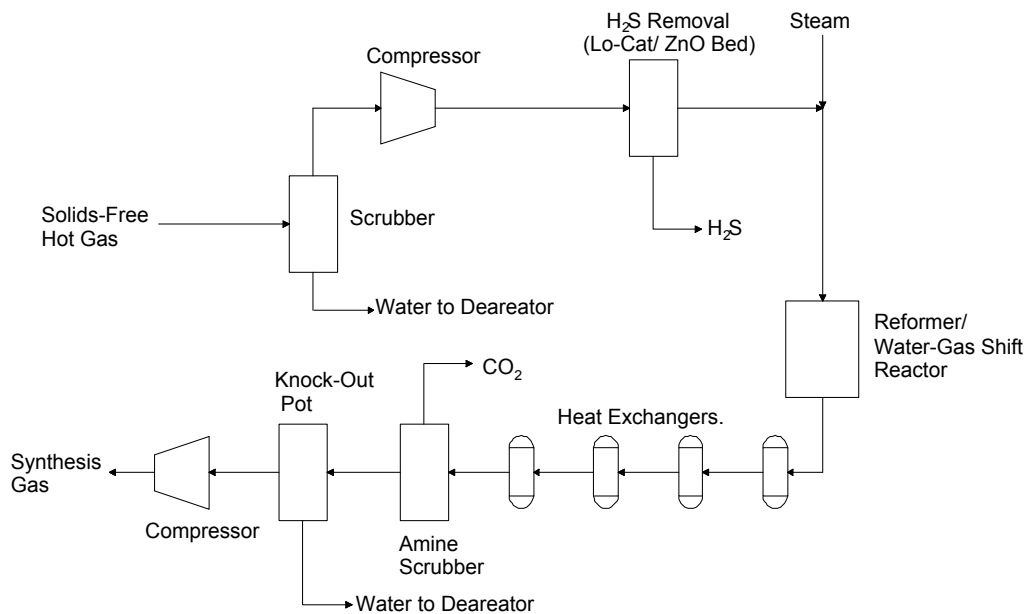

Figure 2.3. Gas Purification and Conditioning Section for Both Gasifier Types

The principal differences in the gas purification and conditioning section for the two gasifier configurations are in the compression costs. The indirectly heated gasifier system produces low-pressure syngas that requires significant compression prior to gas cleanup. The directly heated gasifier produces pressurized raw syngas that requires less compression. In addition, the indirectly heated gasifier syngas

composition is such that steam and compressed, recycled CO₂ is needed in the steam reformer to obtain the desired H₂:CO ratio for the synthesis step. The gas from the directly heated gasifier needs only steam addition to the steam reformer.

2.2.1 Tar Removal

During gasification, a small fraction of the biomass is converted into tars that consist primarily of functionalized aromatic and poly-aromatic hydrocarbons. The tars will foul the downstream process equipment if allowed to condense. While they comprise only a small fraction of the wood feed, they contain significant quantities of carbon and hydrogen, which are important sources for CO and H₂. Therefore, cracking these tars into small hydrocarbons is preferred over condensing them in the water scrubber and discharging them with the wastewater.

The raw gas from the cyclone separator in the gasifier section is sent to a catalytic tar cracker, which is assumed to be a bubbling fluidized-bed reactor. A portion of the tar, methane, and other light hydrocarbons in the raw gas react with steam and are converted to CO and H₂, while NH₃ is decomposed to N₂ and H₂. Benzene and naphthalene are used to represent the aromatic and polyaromatic (C₁₀₊) tar components (Spath et al. 2005). The tar reformer is simulated by using an isothermal equilibrium reactor model and the conversion of each compound is simulated by specifying conversion fractions for each reaction. These fractions are listed in Table 2.3 (Spath et al. 2005). The gas enters the tar reformer at the gasifier outlet temperature and exits the reformer at 1383°F.

Table 2.3. Design Performance of Tar Reformer

Compounds	Conversion Percentage
Methane (CH ₄)	20%
Ethane (C ₂ H ₆)	90%
Ethylene (C ₂ H ₄)	50%
Acetylene (C ₂ H ₂)	50%
Tars (C ₁₀₊)	95%
Benzene (C ₆ H ₆)	70%
Ammonia (NH ₃)	70%
(Converts to N ₂ and H ₂)	

2.2.2 Water Scrubber/Acid Gas Removal

After tar and other organic impurities are reduced in the tar cracker, the gas is cooled to 300°F using heat exchangers. The gas is then scrubbed and cooled in a venturi scrubber and a spray quench chamber to remove impurities such as particulates, NH₃, and other residual tars. Most of the scrubber water is recirculated to the quench sprayers. The purged scrubber water with impurities is sent to a wastewater treatment facility. Because the low concentrations of unconverted tar components preclude condensation, the model assumes that these components pass through the scrubber.

The cooled, scrubbed gas is compressed to 450 psig using a centrifugal compressor. For the indirectly heated gasifier, which operates at near ambient pressure, the compressor consists of five stages with interstage cooling and intercooler temperatures of 140°F. For each compressor stage, a small amount of water is condensed and collected from the gas in each interstage cooler. The directly heated gasifier operates at 300 psig and only requires a single-stage compressor. Any remaining water in the gas

exiting the compressor for either system is removed in a knock-out pot. Water collected from the knock-out pot (and from the interstage coolers for the indirectly heated gasifier system) is sent to the steam cycle and electric power generation section of the plant.

The pressurized gas contains a large amount of methane and other light hydrocarbons that represent a significant fraction of the total carbon and hydrogen in the biomass feed. Therefore, reforming is performed to convert these compounds to CO and H₂. However, the cleaned gas contains approximately 100 ppmv H₂S and lesser amounts of other sulfur compounds (COS, CS₂, mercaptans) that will poison reforming catalysts. Therefore, a liquid-phase oxidation (Lo-Cat) process followed by a ZnO polishing bed is used for sulfur removal. The Lo-Cat process, which is shown in Figure 2.4, removes the bulk of the sulfur (Spath et al. 2005), and is a liquid oxidation process licensed by Merichem (2008).

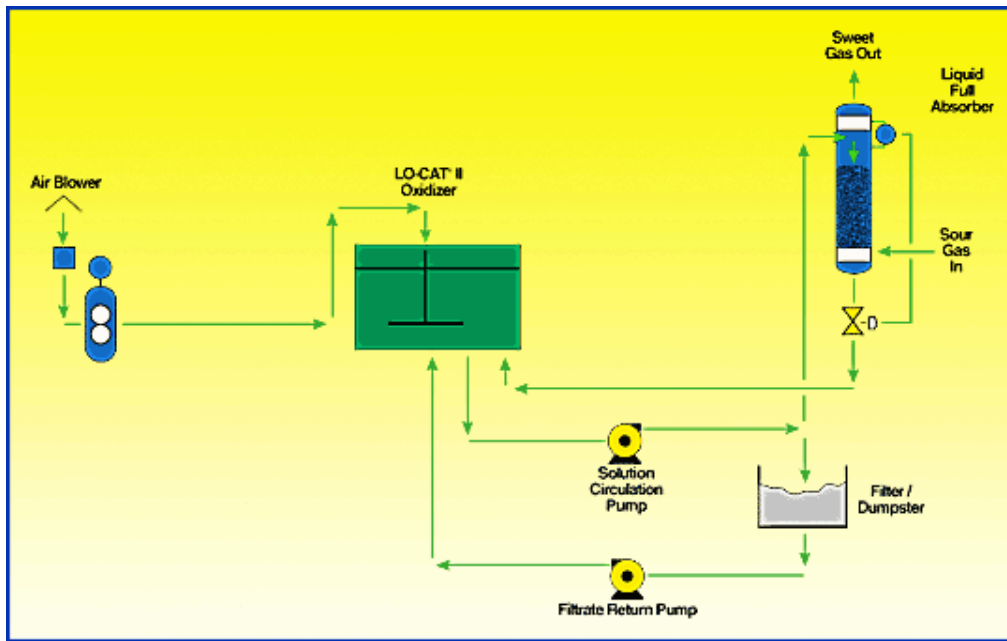

Figure 2.4. Lo-Cat Process (courtesy of the Merichem website, 2008)

The gas is heated to 120°F, and then sent to the Lo-Cat process where H₂S is absorbed and converted to elemental sulfur in an iron chelate-based solution (Ullmann 2006; Merichem 2008). The Lo-Cat process is assumed to remove the sulfur to a concentration of 10 ppm H₂S (Spath et al. 2005).

A fixed-bed ZnO desulfurization unit is used to polish the gas by reducing the sulfur level to less than 1 ppmv (Spath et al. 2005). H₂S is captured by the ZnO sorbent as shown:



The ZnO reactor includes a layer of hydrogenation catalyst, which converts the organic sulfur compounds to H₂S and other unsaturated hydrocarbons in the raw gas to saturated hydrocarbons (Ullmann 2006). Gas leaving the hydrogenation stage is heated to 707°F using heat from the flue gas exiting the reformer furnace. Spent sorbent is disposed of as waste. Both the Lo-Cat system and the ZnO system are modeled with component separators.

2.2.3 Methane Reforming and Water-Gas Shift Reactor

Gas leaving the ZnO bed is sent to a steam reformer to convert the remaining methane, light hydrocarbons, and tar components to additional syngas and to adjust the H₂:CO ratio via the WGS reaction. The main steam-reformer reactions are:

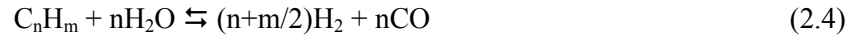

Before the gas is sent to the steam reformer, it is mixed with high-temperature steam from the steam system. A portion of the CO₂ from the amine unit located downstream of the steam reformer may be compressed and added to the gas stream, if needed, to adjust the H₂:CO ratio. The mixture is sent to the reformer, which consists of tubes filled with nickel catalyst. Heat for the endothermic reforming reaction, which takes place in the temperature range 800° to 900°C, is supplied by burning the off-gas from the mixed alcohol synthesis section.

Heat from the hot flue gas in the reformer convection zone is recovered by providing reformer feed preheat and generating high pressure, superheated steam. The reformed syngas passes through several heat exchangers to recover heat by generating high-pressure steam, heating boiler feed water, or heating process steam. The cooled syngas from the reforming process is cooled further by an air cooler to 150°F and then trim cooled to 110°F with cooling water. The condensed water from syngas is collected and returned to the scrubbing unit.

The steam reformer was modeled using two Gibbs type reactors in CHEMCAD. The heat duty estimated by the Gibbs reactor for the steam-reforming reactions is matched by the duty in the second Gibbs reactor simulating the burners with a bridgewall temperature of 1800°F.

2.2.4 CO₂ Removal and Compression

The dry, cool syngas is sent to an amine system to remove 99% of the CO₂. Removing CO₂ reduces the volume of syngas, which in turn reduces the downstream equipment sizes and compressor power consumption. In the amine process, CO₂ reacts reversibly with the alkaline solvent to form carbamate. A portion of the absorbed CO₂ is recovered for use elsewhere in the plant as needed. In the indirectly heated gasifier *Base Case*, 22% of the captured CO₂ is sent to the reformer to adjust the H₂:CO ratio. For the directly heated gasifier cases, CO₂ is not needed to adjust the H₂:CO ratio. However, because of the high-pressure gasification operation, some recycle CO₂ is compressed and used to pressurize the lock hopper and pneumatically convey and feed the dry wood into the gasifier.

The treated syngas is sent to a multiple-stage, intercooled compressor and compressed from 413 to 2000 psi. This is simulated by using a three-stage reciprocating compressor with an isentropic efficiency of 78% and an intercooler temperature of 140°F.

2.2.5 Heat Recovery

The heat recovery in the gas purification and compression section uses the heat from the hot syngas leaving the reformer and the flue gas from reformer furnace. For the indirectly-heated gasifier cases, the

hot reformed syngas at 1650°F is first used to superheat the high-pressure saturated steam at (1265 psi) to 1000°F, which is sent to the steam turbine. The syngas leaving the reformer is cooled in a heat exchanger that superheats intermediate-pressure saturated steam (450 psi) from the mixed alcohol synthesis reactor to 720 °F, which is sent to the intermediate stage of the steam turbine. Finally, the partially cooled syngas is sent to the third heat exchanger to heat the boiler feed water to generate saturated steam at 575°F and 1280 psi. The syngas is cooled to 250°F before being sent to an air cooler. The hot flue gas exiting the reformer furnace is first used for preheating the inlet syngas to the reformer. Then, the flue gas at 1450°F superheats the saturated steam at 1265 psi to 1000°F. Finally, the flue gas passes through two heat exchangers where it provides feed preheat for the Lo-Cat and ZnO processes.

The heat recovery section for the directly heated gasifier cases is similar to that of the indirectly-heated gasifier system except that the hot flue gas from the reformer furnace is used to generate superheated steam first before preheating the inlet syngas. The reason for this difference is that the inlet syngas flow rate is much greater for the directly heated gasifier than that of the indirectly-heated gasifier. If the flue gas is first used to preheat the inlet gas, the temperature is too low to be used to generate superheated steam.

2.3 Alcohol Synthesis and Product Recovery Model

Figure 2.5 shows the mixed alcohol synthesis process. Syngas is converted into an ethanol-rich mixed alcohol product in an alcohol synthesis reactor followed by product gas/liquid separation using a series of flash vessels and a stabilization column to degas the liquid product. The liquid product is dewatered using a molecular sieve column and further purified in a series of distillation units to recover methanol, ethanol, propanol, butanol, and pentanol. This section is the same for both the indirectly heated and the directly heated gasifier cases.

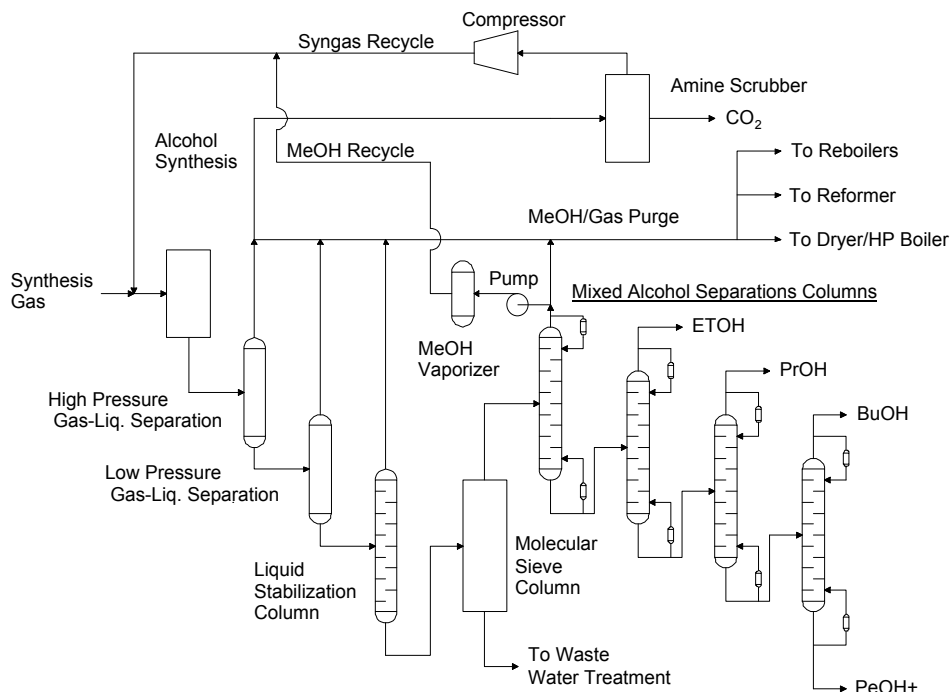
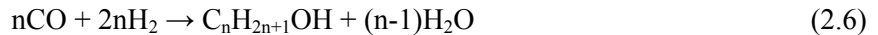

Figure 2.5. Mixed Alcohol Synthesis and Purification Section

2.3.1 Alcohol Synthesis Reactor

Mixed alcohol synthesis involves the reaction between CO and H₂ under high pressures (800 to 2500 psig) and moderate temperatures (180 to 350°C) to produce a mixture of C₁ to C₆ mono-alcohols. In addition, hydrocarbon gases, liquids, and even solids (waxes) may be produced as byproducts, depending on the catalyst chosen and the reaction conditions. In addition, some mixed alcohol synthesis catalysts also catalyze the WGS reaction, resulting in the conversion of a significant portion of the CO to CO₂.

Mixed alcohol synthesis involves multiple reactions with different pathways to various alcohols and hydrocarbons. The overall stoichiometric reaction for higher alcohol synthesis is (Hutchings et al. 1988; Wong et al. 1986):



with the value of “n” typically ranging from 1 to 6. Hydrocarbon synthesis takes place according to a similar reaction scheme:

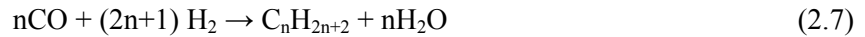

or



The distribution of hydrocarbons generally follows the Anderson-Schulz-Flory Distribution that is typical for FT synthesis. While the stoichiometry of these reactions suggests an optimum H₂/CO ratio of approximately 2.0, the optimal ratio is closer to 1.0 if the catalyst is significantly active for the WGS reaction (Equation 2.3).

This study assumes a modified FT catalyst (K/Co/MoS₂ catalyst) because of its relatively high alcohol selectivity and its main product mixture of linear alcohols. It also is capable of converting recycled methanol to higher alcohols, thereby achieving an overall high selectivity to C₂+ alcohols. A description of this model can be found in Aden et al. (2005), which draws on several literature sources (Forzatti et al. 1991; Herman 1991; Courty et al. 1990; Quarderer 1986).

Table 2.4 summarizes the synthesis reactor design assumptions. Clean syngas at 2000 psi is preheated to 570°F (299°C) in a feed-product exchanger. The mixed-alcohol reactor is assumed to be a fixed-bed tubular design with steam produced in the shell. The product gas is partially cooled by the inlet compressed syngas, followed by further cooling to condense the alcohols and water. Most of the unconverted syngas is recycled. Ninety percent of the methanol product also is recycled to the reactor to increase the conversion efficiency. The liquid alcohols are then sent to the alcohol-separation and purification processes. The methanol purge stream and the product-gas purge stream are combined and sent to the steam-cycle and power-generation section of the plant for power generation.

The mixed alcohol synthesis reactions are exothermic and release a large amount of heat that is removed from the reactor by vaporizing boiler feed water on the shell side of the reactor. Approximately 2.5 lb of 450 psi steam/lb of ethanol is produced. The medium pressure steam is superheated by the syngas leaving the reformer in the Gas Purification and Conditioning Section and then used to drive the medium-pressure steam turbine in the steam Cycle and Power Recovery Section for electric power generation.

Table 2.4. Design Assumptions for Mixed Alcohol Synthesis

Catalyst	Modified FT
Temperature (°F)	570
Pressure (psia)	2000
Reactor Design	Fixed Bed
H ₂ /CO Ratio	1.2
CO ₂ inlet concentration	0.2 mol%
Gas hourly space velocity, L/Lcat/hr	3000

The reactor is simulated in CHEMCAD with a stoichiometric reactor model. Table 2.5 shows the main reactions modeled involving CO and recycled methanol. The specific conversions of CO and recycled methanol, also shown in the table for each of the main reactions, are set to reach catalyst performance targets that are consistent with those reported by Aden et al. (2005). Note that the methanol conversion equations apply only to recycled methanol and not to the methanol produced by the main CO/H₂ reactions in reaction 4.

Table 2.5. Reaction Stoichiometry and *Base-Case* Reactant Conversions for Mixed Alcohol Synthesis

Reaction No.		Mol% CO Conversion (per pass):
1	CO + H ₂ O → CO ₂ + H ₂	13.0%
2	CO + 3 H ₂ → CH ₄ + H ₂ O	4.5%
3	2 CO + 4 H ₂ → C ₂ H ₆ + H ₂ O	0.5%
4	CO + H ₂ → Methanol	4.1%
5	2 CO + 4 H ₂ → Ethanol + H ₂ O	11.4%
6	3 CO + 6 H ₂ → Propanol + 2 H ₂ O	3.0%
7	4 CO + 8 H ₂ → n-Butanol + 3 H ₂ O	1.0%
8	5 CO + 10 H ₂ → n-Pentanol + 4H ₂ O	0.5%
	Total CO Conversion	38%
Reaction No.	Reaction	Mole % Recycled Methanol Conversion (per pass):
9	Methanol + CO + 2 H ₂ → ethanol + H ₂ O	58%
10	Methanol + 2 CO + 4H ₂ → Propanol + 2 H ₂ O	7%
11	Methanol + 3 CO + 6 H ₂ → n-Butanol + 3 H ₂ O	4.5%
12	Methanol + 4 CO + 8 H ₂ → n-Pentanol + 4H ₂ O	2%
	Total Recycled Methanol Conversion	71.5%

2.3.2 Product Gas Recycle

The product gas leaves the alcohol-synthesis reactor at 570°F (299°C) and is cooled by heat exchange with the reactor feed syngas to 300°F (149°C). The gas is further cooled in an air-fin exchanger to 150°F (66°C) and then trim cooled to 110°F (43°C) using cooling water. Condensed alcohols and water are separated from the gas in high- and low-pressure flash drums. The liquid stream is sent to the purification processes. The high-pressure gas stream containing H₂, CO, CH₄, and CO₂, is passed through a high-pressure amine system to remove CO₂ from the gas stream and then recycled to the inlet of the alcohol-synthesis reactor. The low-pressure off-gas is sent to the fuel-gas system.

In the indirectly heated gasifier systems, 98% of the treated product gas is recycled, and the remainder purged from the system to limit the build-up of methane in the syngas entering the alcohol-synthesis reactor. A portion of the 2% purge gas is sent to the steam reformer as fuel for the burner. The remaining portion of the purge gas is sent to the boiler in the steam cycle for power generation and to the distillation columns that require fired re-boilers.

In the directly heated gasifier system, 96% of the unconverted product gas is recycled. A lower recycle rate is required because more fuel gas is needed to fire the steam reformer than that required by the indirectly heated gasifier system. A portion of the purge gas is used in the biomass feed dryer, and a portion is sent to the distillation columns that require fired re-boilers.

2.3.3 Liquid Separation and Purification

The crude liquid product stream from the gas/liquid separators is sent to a stabilization column to remove the non-condensable gases, and the gases are sent to the fuel-gas system. The liquid product leaving the stabilization column is vaporized and sent to molecular sieve drying columns, where it is assumed that all the water is removed. The dried product stream is condensed and then sent to a distillation column, where 99% of the methanol is recovered overhead at purity greater than 99%. The bottoms product from the methanol column is sent to a second distillation column where 99.95% of incoming ethanol is recovered in the overhead stream and 99% of the propanol is recovered in the bottom stream along with the higher alcohols. The bottom stream is sent to two distillation towers where propanol and butanol are recovered in the two towers. The bottom stream from the final distillation column mainly contains higher mixed alcohols. The CHEMCAD SCDS rigorous distillation column unit operation is used to model each distillation column.

2.3.4 Methanol Byproduct Recycle

Ninety percent of the methanol stream from the methanol column is recycled to the mixed-synthesis reactor to where it is further converted to higher alcohols (mainly ethanol). The remaining methanol stream is used as fuel.

2.4 Steam-Cycle and Power-Generation Model

The Steam and Power Generation Area generates power and process steam using extraction steam turbines. High-pressure steam is recovered from the gas-cooling sections of the gasifier and steam reformer. Medium-pressure steam is generated by cooling the mixed-alcohol reactor. The main differences in the steam systems for the indirectly heated and directly heated gasifier systems (shown in Figures 2.6 and 2.7) are the sources of high-pressure steam, and the disposition of medium- and low-pressure steam. The indirectly heated gasifier system produces more fuel gas than needed by the steam reformer and distillation tower re-boilers. Hence, the steam system includes a separate boiler and gas turbine where excess fuel gas is burned to generate high-pressure steam in a boiler for use in the steam turbines.

High-pressure saturated steam generated by heat recovery in the gasifier and steam reformer sections, or by a separate boiler in the indirectly heated gasifier cases, is superheated and sent to a high-pressure steam turbine to produce electricity. Medium-pressure steam leaving the high-pressure steam turbine is

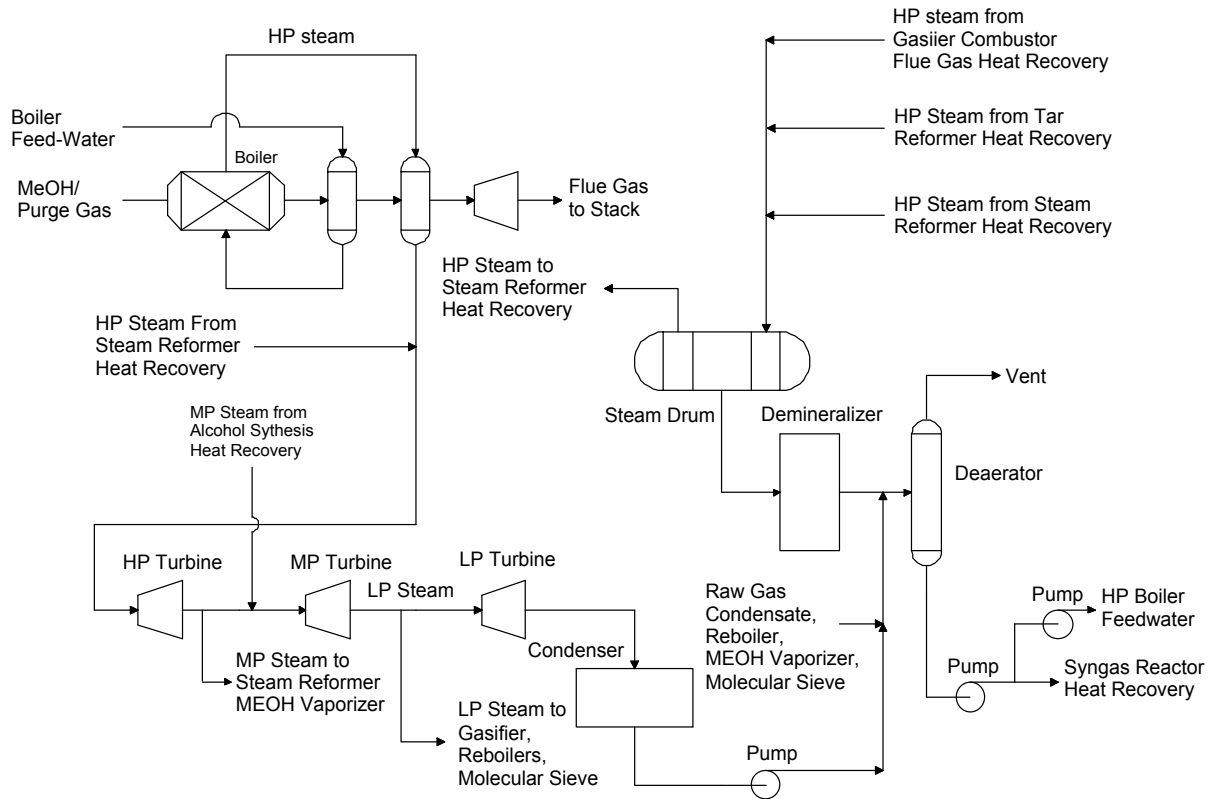

Figure 2.6. Steam and Power Generation Section for the Process Using and Indirectly Heated Gasifier

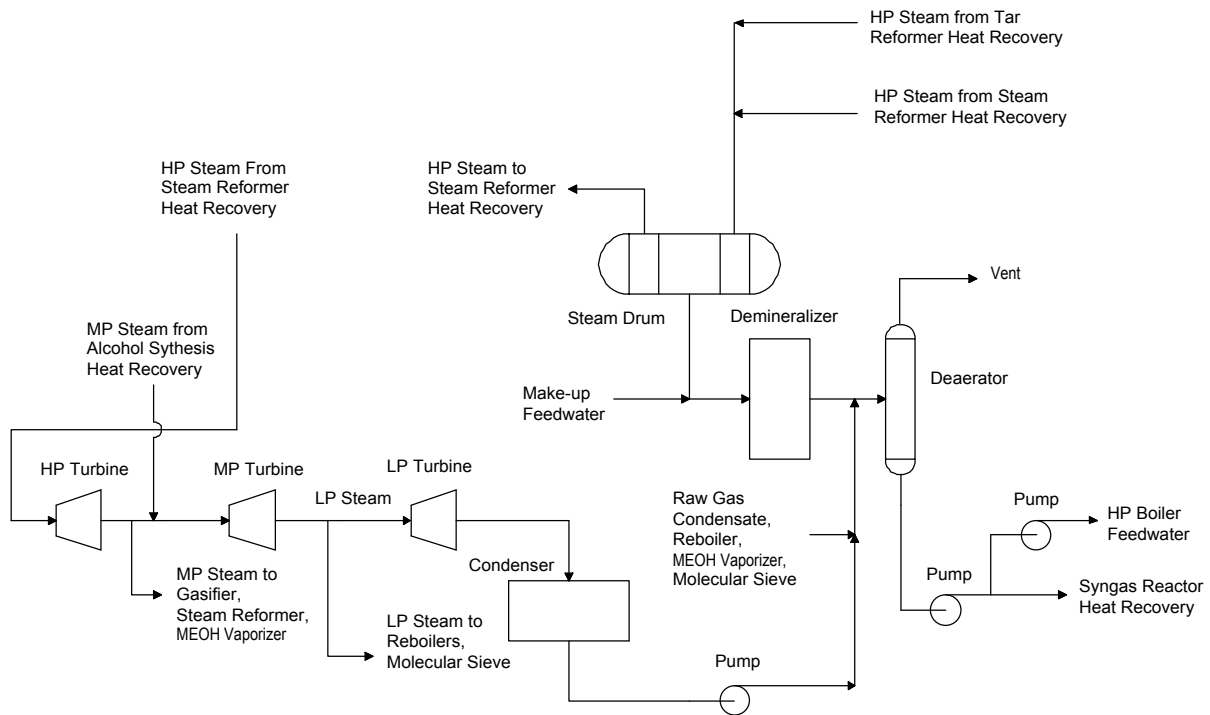

Figure 2.7. Steam and Power Generation Section for the Process Using a Directly Heated Gasifier

combined with medium-pressure steam recovered from the alcohol-synthesis reactor and passed through a second medium-pressure steam turbine to produce electricity. Medium-pressure steam is extracted from the turbine and sent to the steam reformer and methanol vaporizer for both systems. Low-pressure steam leaving the medium-pressure steam turbine is extracted to provide heat to the molecular sieve column and some of the distillation columns for both systems. Medium-pressure steam is used in the directly heated gasifier, while the indirectly heated gasifier uses low-pressure steam. Steam leaving the lowest pressure turbine stage is condensed and returned to the de-aerator along with condensate from process heaters.

2.5 Overall Process Modeling and Cost Estimation Methodology

Process modeling was performed using the CHEMCAD software program. CHEMCAD software includes energy and material-balance models for most unit operations in the system including compressors, boilers, steam generators, heat exchangers, and distillation columns. Special processes such as the gasifiers, tar crackers, and ethanol-synthesis reactors were modeled in Excel spreadsheets using available experimental data. These process models are discussed in more detail in Appendix A.

The modeling results produce inlet and outlet process flow-rate and compositional information for each unit operation based on key operating parameters, such as pressure and temperature as well as any energy consumed or produced by the process where applicable. This information was used to size equipment and develop operating costs for the plant. The *Base Cases* for both types of gasifiers represent what is believed to be the current state-of-the-art for the various unit operations. It is understood that there are other technology choices for some of the unit operations including reforming, acid-gas removal, and alcohol synthesis and product recovery.

The equipment costs assume that this is the “nth” plant; that is, all research and development required to commercialize the process at the given scale is complete, and the manufacturing processes are mature and the equipment readily available.

The equipment costs were estimated by scaling the *Basis-Case* equipment costs by the appropriate metric (e.g., flow, duty, etc.) and applying an appropriate scaling factor:

$$(\text{Cost } \$) = (\text{Base Cost } \$) * [(\text{Capacity}) / (\text{Base Capacity})]^{(\text{scaling factor})} \quad (2.9)$$

Appendix B summarizes the cost bases and scaling exponents for specific equipment identified for each process along with the number of units of each piece of equipment needed for each unit operation.

Most of the base equipment costs for the feed-preparation, gas-purification and conditioning, and steam-cycle and power-generation sections of the plant were obtained from Spath et al. (2005). The Spath et al. report is an economic analysis of hydrogen production from biomass using an indirectly heated gasifier. Gasifier costs for both types of gasifiers were obtained from Hammelinck et al. (2001). The ASPEN Icarus costing program was used to cost most of the equipment in the alcohol synthesis and purification section of the plant and to select equipment within the gasification and gas purification and conditioning sections. Specialized equipment, such as the two gasifier systems, tar reformer, amine scrubber systems, molecular sieve alcohol dryer, and air separation unit, were costed using other reference sources. Table B.1 summarizes the costing sources, cost bases, and scaling exponents for specific equipment identified for each process, along with the number of units of each piece of equipment needed for each unit operation.

All capital costs are reported in first quarter (1stQ) 2007 dollars. The Chemical Engineering Plant Cost Index (CEPCI) was used to escalate equipment costs (Chemical Engineering Magazine 2006a, b, c):

$$\text{Cost in 1stQ 2007} = \text{Base Year Cost} * (\text{1stQ 2007 CEPCI})/(\text{Base Year CEPCI}) \quad (2.10)$$

Table B.1 in the Appendix B also provides the basis year for each piece of equipment in addition to the basis year cost. Installed equipment costs were calculated by multiplying the equipment cost by the installation factor also shown for each piece of equipment in Table B.1.

The total capital investment is factored from installed equipment costs. The factors are shown in Table 2.6 (Peters and Timmerhaus 2003) excluding the service facilities. Service facilities (i.e., support systems that are usually associated with the outside battery limits) are included in the detailed equipment list.

Table 2.6. Total Project Investment for the Design Case Standalone Plant

Total Purchased Equipment Cost (TPEC)	100%	
Purchased Equipment Installation	39%	of TPEC
Instrumentation and Controls	26%	of TPEC
Piping	31%	of TPEC
Electrical Systems	10%	of TPEC
Buildings (including services)	29%	of TPEC
Yard Improvements	12%	of TPEC
Service Facilities (installed)	0%	of TPEC
Total Installed Cost (TIC)	247%	
Indirect Costs		
Engineering	32%	of TPEC
Construction	34%	of TPEC
Legal and Contractors Fees	23%	of TPEC
Project Contingency	37%	of TPEC
Total Indirect	126%	
Total Capital Investment (TCI)	373%	

Production cost assumptions are listed in Table 2.7. An annualized product value is a simple, yet convenient, way to compare differences between processing options while capturing the effects of changes in capital and operating costs. Table 2.7 shows the assumptions used to arrive at the annualized product value and assumes no time value of money. Working capital, start-up costs, interest, and income taxes are excluded. The pre-tax product value is calculated as:

$$\text{Product value} = \text{Variable Costs} + \text{Fixed Costs} + \text{Depreciation} + \text{G\&A Costs} + \text{ROI} \quad (2.11)$$

Table 2.7. Economic Assumptions

Raw Materials	Value	Reference
Hybrid Poplar Chips, \$/dry short ton	35	Phillips et al 2007
Ash Disposal, \$/short ton	18	Phillips et al 2007
Olivine, \$/short ton	179.2	Phillips et al 2007
Misc. Chemicals, \$/gal ethanol	5	Estimated from Phillips et al 2007
Tar Reformer Catalyst, \$/gal ethanol	5	Estimated from Phillips et al 2007
Mixed Alcohol Catalyst, \$/lb catalyst	50	assumption
Utilities		
Natural Gas, \$/1000scf (1000 BTU/scf)	8.47	EIA
Electricity, ¢/kwh	6.75	EIA
Cooling Water, ¢/1000 gallons	6	Wang 2003
Waste water treatment, \$/100 ft ³	2.28	(EBMUD.com, BCC 2600)
Stream Factor	90%	assumption
Construction		
	Overnight ^(a)	assumption
Plant life, yrs	20	Phillips et al 2007
Straight Line Depreciation, yrs	20	assumption
Rate of return on capital, %	10% of capital investment	Phillips et al 2007
Labor		
Operating labor, \$/hr burdened & 10% shift overlap	37.66	Wang 2003
Maintenance labor	0.9% of TIC	Wang 2003
Control Lab labor	20% of operating labor	Wang 2003
Operator per shift per major unit	1	estimated
Materials		
Maintenance	0.6% of TIC	Wang 2003
Operating Supplies	10% of operating labor	Wang 2003
Overhead		
	80% of total labor	Wang 2003
Local taxes & insurance	2% of total fixed capital	Wang 2003
General & administrative, sales and research	5% of product value	Wang 2003

(a) "Overnight construction" means no costs such as construction loans are associated with the construction phase (i.e., construction is as if it happens "overnight").

3.0 Results and Analysis

This chapter describes the results of modeling and cost analyses for the base and alternative scenario cases for both gasifier configurations. The selected parameters for the scenario analysis include gasification temperature, pressure, tar production, and the H₂:CO ratio of the raw product gas from the gasifier. The alternative scenario analyses examine how changes to the *Base Case* assumptions affect processing costs, and identifies which assumptions have significant impact and where there are important gaps in the current technology.

3.1 Indirectly Heated Gasifier Scenarios

Seven cases are considered for the mixed alcohols synthesis plant with syngas produced by an indirectly heated gasifier:

- Base Case:* The gasifier syngas composition is based on correlations developed by Spath et al. (2005) for an indirectly heated gasifier. The balance-of-plant processing assumptions and unit-operation configurations are similar to those used by Spath et al. (2005) and Aden et al. (2005).
- Case A1:* The gasifier raw syngas composition has a H₂:CO ratio that is close to 2:1 versus approximately 0.5 for the *Base Case*.
- Case A2:* The gasification pressure is increased to 147 psi (10 atm) compared to 23 psig for the base case. Because the gasifier model does not include a pressure factor, the syngas composition is assumed to be the same as that predicted at atmospheric pressure.
- Case A3:* The steam reformer is replaced by a simple shift reactor. Methane and ethane are assumed to be inert in the synthesis step. The total syngas pressure is increased to maintain the same H₂ and CO partial pressures as in the *Base Case*.
- Case A4:* The same assumptions as in Case A3 apply, except that the total syngas pressure is unchanged from the *Base Case*.
- Case A5:* The tar production rate is double that of the *Base Case*.
- Case A6:* The tar production rate is half that of the *Base Case*.

Table 3.1 summarizes the operating conditions and performance results for each case, while Table 3.2 and Table 3.3 list the associated costs.

3.1.1 Base Case

The indirectly heated gasifier *Base Case* used the process configurations shown in Figures 2.1, 2.3, 2.4, 2.5 and 2.6. The following key operating parameters for the gasifier and alcohol synthesis reactor shown in Table 3.1 are similar to those used by Aden et al. (2005):

- Gasifier Pressure – 23 psig
- Gasifier Temperature – 1598°C
- Alcohol synthesis Reactor Temperature – 300°C
- Alcohol Synthesis Reactor Pressure – 2000 psig
- Alcohol Synthesis Reactor Feed-Gas H₂:CO ratio – 1.2.

Table 3.1. Performance Results for Indirectly Heated Gasifier Based System Models

Case	Base	A1	A2	A3	A4	A5	A6
Case Description	Base	1.7:1.0 H ₂ :CO Ratio	Increased Gasifier Pressure	No Steam Reformer Const. H ₂ , CO partial Pressures	No Steam Reformer Constant Total Pressure	Double Tar Conc.	One-Half Tar Conc.
Gasifier Pressure, psi	23	14.7	147	23	23	23	23
Gasifier Temperature, °F	1598	1652	1598	1598	1598	1598	1598
Raw Gas Compositions, Mol%							
Hydrogen	12.9	19.2	12.7	12.9	12.9	12.7	12.9
Carbon monoxide	22.8	11.1	22.5	22.8	22.8	22.5	22.9
Carbon dioxide	6.9	11.1	8	6.9	6.9	6.8	6.9
Methane	8.3	4.8	8.2	8.3	8.3	8.2	8.3
Water	45.6	52.2	45	45.6	45.6	45.9	45.4
Benzene	0.07	0.05	0.07	0.07	0.07	0.14	0.03
Naphthalene	0.13	0.1	0.12	0.13	0.13	0.25	0.06
C ₂ +	2.7	1	2.7	2.7	2.7	2.7	2.7
H ₂ :CO ratio	0.57	1.74	0.57	0.57	0.57	0.57	0.57
Char Production, lbmole/hr	33970	42660	33970	33970	33970	33970	33970
Scrubbed (dry) raw gas flow rate, lbmol/hr	8438	9068	8568	8438	8438	8699	8267
Alcohol synthesis Pressure, psi	1995	1995	1995	2091	1995	1995	1995
Alcohol Synthesis Temperature, °F	570	570	570	570	570	570	570
Clean syngas composition, mol%							
Nitrogen	0.4	0.4	0.3	0.4	0.4	0.4	0.4
Hydrogen	49.4	51.4	49.5	47.2	47.2	49.1	49.1
Carbon monoxide	41.6	43.7	42.1	39.7	39.7	41.6	41.9
Carbon dioxide	0.2	0.3	0.2	0.2	0.2	0.2	0.2
Methane	8.4	4.2	7.9	10.4	10.4	8.7	8.4
Water	0	0	0	0	0	0	0
C ₂ +	0	0	0	2.1	2.1	0	0
H ₂ :CO ratio	1.19	1.18	1.18	1.19	1.19	1.18	1.17
Clean Syngas Flowrate, lbmol/hr	8645	8247	8734	7656	7656	8798	8517
Final Products, MM gal/yr							
Ethanol	37.6	37.7	38.5	31.7	31.8	38.3	37.3
Propanol	7.6	7.6	7.8	6.4	6.4	7.7	7.5
Butanol	3.3	3.3	3.3	2.8	2.8	3.3	3.2
Pentanol	1.6	1.6	1.7	1.4	1.4	1.7	1.6
Total	50.1	50.2	51.3	42.3	42.3	51	49.7
Carbon Efficiency, %	25	25	25.6	21.1	21.1	25.5	24.8
Power Consumption, MW							
Lock hopper gas compressor	0	0	-0.1	0	0	0	0
Air compressor	-4.8	-6.1	-16.9	-4.7	-4.7	-4.7	-4.7
Raw syngas compressor	-16.8	-18.1	-5	-17	-17	-17.5	-16.6
Reformer air compressor	-1	-1.4	-1.1	0	0	-1.1	-1
CO ₂ compressor	-0.5	-2.5	-0.5	0	0	-0.5	-0.5
Clean syngas compressor	-6.9	-6.6	-6.9	-6.1	-5.9	-7	-6.8
Recycle compressor	-0.3	-0.2	-0.3	-0.4	-0.4	-0.3	-0.3
Boiler air compressors	-0.9	-0.1	-0.8	-2.2	-2.1	-1	-0.9
miscellaneous	-8	-8	-8	-8	-8	-8	-8
Power Production, MW							
Steam turbines	50.8	47.6	50.8	60.5	60.5	52.5	50.3
Net Power Output, MW	11.5	4.5	11.2	22.1	22.3	12.4	11.4

Table 3.2. Equipment and Capital Cost Results for Indirectly Heated Gasifier Based System Models

Case	Base	A1	A2	A3	A4	A5	A6
Case Description	Base	1.7/1.0 H ₂ /CO Ratio	Increased Gasifier Pressure	No Steam Reformer Const. H ₂ , CO partial Pressures	No Steam Reformer Constant Total Pressure	Double Tar Conc.	One- Half Tar Conc.
Installed Equipment Costs, mm\$							
Feed prep and drying	24.7	25.6	35.9	24.7	24.7	24.7	24.7
Gasifier and cyclones	33.0	39.5	37.2	33.0	33.0	33.0	33.0
Tar cracker	4.4	5.3	4.4	4.4	4.4	4.4	4.4
Gasifier heat recovery	0.5	0.6	0.5	0.5	0.5	0.5	0.5
Syngas compression	23.5	23.9	4.8	23.6	23.6	23.9	23.4
Sulfur removal	3.6	3.6	3.6	3.6	3.6	3.6	3.6
Steam reformer (SR)	12.0	14.6	12.5	0.0	0.0	11.7	12.0
WGS	0.0	0.0	0.0	0.9	0.9	0.0	0.0
SR or WGS heat recovery	3.4	3.9	3.5	0.9	0.9	3.5	3.3
SR or WGS CO ₂ compressor	0.4	1.0	0.4	0.0	0.0	0.4	0.4
Amine CO ₂ removal	20.2	28.3	21.3	19.1	19.1	20.1	20.0
Clean syngas compression	8.6	8.3	8.7	8.2	8.1	8.7	8.5
Mixed alcohols synthesis	43.3	34.4	42.2	49.4	46.7	44.1	42.7
Mixed alcohol recycle	17.8	17.6	18.5	17.6	16.0	18.0	17.6
Mixed alcohol separations	12.8	12.9	13.1	11.3	11.3	12.9	12.7
Steam system and power generation	19.8	18.0	19.3	26.3	26.3	20.2	19.6
Remainder OSBL	3.7	3.8	3.6	3.7	3.7	3.7	3.7
Total Installed, mm\$	232	241.4	229	227	223	233	230
Total Indirect, mm\$	118	123.1	117	116	114	119	117
Total Capital Inv, mm\$	350	364.5	346	343	336	353	348

Table 3.3. Operating Cost Results for Indirectly Heated Gasifier Based System Models

Case	Base	A1	A2	A3	A4	A5	A6
Case Description	Base	1.7/1.0 H ₂ /CO Ratio	Increased Gasifier Pressure	No Steam Reformer Const. H ₂ , CO partial Pressures	No Steam Reformer Constant Total Pressure	Double Tar Conc.	One- Half Tar Conc.
Variable Costs, \$mm/yr							
Hybrid Poplar Chips	25.330	25.330	25.330	25.330	25.330	25.330	25.330
Olivine makeup	0.307	0.307	0.307	0.307	0.307	0.307	0.307
Ash disposal	0.405	0.405	0.405	0.405	0.405	0.405	0.405
Misc Chemicals	1.881	1.885	1.925	1.587	1.588	1.915	1.867
Tar Reformer Catalyst	0.376	0.377	0.385	0.317	0.318	0.383	0.373
Mixed Alcohols Catalyst	0.223	0.157	0.210	0.235	0.235	0.226	0.210
Wastewater treatment	1.463	1.692	1.296	1.495	1.493	1.447	1.460
Cooling water	3.195	3.489	2.493	3.298	3.293	3.190	3.177
Natural gas	0.000	0.000	0.000	0.000	0.000	0.000	0.000
Electricity	-6.101	-2.413	-5.967	-11.779	-11.875	-6.595	-6.091
Propanol + Credit ^a	-52.282	-52.212	-53.425	-44.238	-44.247	-53.242	-51.888
Total Variable, \$mm/yr	-25.202	-20.981	-27.042	-23.042	-23.154	-26.634	-24.849
Fixed Costs, \$mm/yr	16.802	17.289	16.677	16.581	16.359	16.893	16.729
Depreciation (5%/yr), \$mm/yr	17.491	18.226	17.294	17.157	16.822	17.629	17.381
Gen & Admin, \$mm/yr	5.071	5.431	4.997	4.697	4.627	5.073	5.048
ROI (10%/yr), \$mm/yr	34.982	36.452	34.589	34.314	33.644	35.258	34.762
EtOH Production, mmgal/yr	37.626	37.708	38.498	31.744	31.767	38.305	37.336
Total Variable, \$/gal EtOH	-0.670	-0.556	-0.702	-0.726	-0.729	-0.695	-0.666
Fixed Costs, \$/gal EtOH	0.447	0.458	0.433	0.522	0.515	0.441	0.448
Depreciation, \$/gal EtOH	0.465	0.483	0.449	0.540	0.530	0.460	0.466
Gen & Admin, \$/gal EtOH	0.135	0.144	0.130	0.148	0.146	0.132	0.135
ROI, \$/gal	0.930	0.967	0.898	1.081	1.059	0.920	0.931
Estimated Selling Price, \$/gal	1.306	1.496	1.208	1.566	1.520	1.259	1.314

The alcohol-product-distribution, CO-conversion, and product-selectivity assumptions for the alcohol synthesis reactor are similar to those used by Aden et al. (2005). Additional details on the base process flow sheet and modeling results are provided in Appendix B.

3.1.2 Case A1: Raw Gas Composition with H₂:CO Ratio Close to 1.7:1

Case A1 examines the effect of producing a raw gas from the gasifier with a significantly higher H₂:CO ratio of approximately 1.7:1. The motivation for this case is that the product gas correlations (Section 2.1.2) are based on a gasifier that was meant to make medium BTU fuel gas to use in place of natural gas in boiler and gas turbine applications. Consequently, the research did not investigate operating parameters that might have improved the H₂:CO ratio to a value more suitable for syngas applications. It also placed a premium on the amount of methane in the raw product gas because it increased the energy density of the product gas. To investigate a case in which the H₂:CO ratio is higher, the raw gas composition is adjusted to be similar to the measured dry composition reported by Hofbauer et al. (2002) adjusted to a wet gas composition using the reported steam addition rate reported by Hofbauer and Rauch (2001) for their indirectly heated gasifier, which used quartz sand as the fluidizing medium. This gasifier produces a medium BTU gas with a 1.7:1 H₂:CO ratio. Using Hofbauer's gas composition also requires adopting the reported operating temperature and pressure of 900°C and 1 atm. As shown in Table 3.1, the methane content of the raw gas is about half that of the *Base Case*, while the water and CO₂ concentrations are higher. The production of tar is calculated from the correlation developed by Spath et al. (2005). The char production and steam injection are adjusted to balance the C, H, and O components of the outlet gas with the inlet feed.

Performance Results. As shown in Table 3.1, the H₂:CO ratio in the raw syngas in *Case A1* is not only higher than that of the *Base Case*, but it also is higher than the specified H₂:CO ratio for mixed alcohol synthesis (H₂:CO = 1.2). The cooled, scrubbed, raw syngas flow rate of *Case A1* is approximately 28% higher than that of *Base Case* and, thus, increases the raw gas compressor power consumption by about 1.2 MW. The higher CO₂ content in raw syngas of *Case A1* also increases the size of amine scrubber system. Because the CO₂ is removed from the raw gas in the amine scrubber, before most of the methane is reformed, the H₂:CO ratio must be reduced by re-injecting a large quantity of CO₂ under pressure into the steam reformer, which increases the CO₂ compressor power consumption.

The lower methane content in the raw gas results in a correspondingly lower concentration of methane in the syngas leaving the reformer. This, in turn, produces a lower total gas flow rate entering the alcohol synthesis reactor.

To match the higher water content of the raw gas leaving the reactor in *Case A1*, additional steam must be injected into the gasifier and passed through the cyclones. Therefore, the steam available for power generation decreases; thus, the total net power output also decreases. In addition, the higher water content in the raw syngas increases the wastewater treatment and cooling water loads in the gas cleanup section.

In *Case A1*, the char production, which is estimated by balancing the mass between the inlet and outlet streams, is higher than that of *Base Case*, which leads to higher air consumption in the combustor and, thus, higher air compressor power consumption.

The change in raw syngas composition has no obvious effects on the product yield and carbon efficiency in the alcohol synthesis and recovery section, which are almost the same for the two cases.

Economic Effects. Table 3.2 summarizes the capital costs associated with the *Base Case* and *Case A1*. Increasing steam to the gasifier increases the total gasifier flow rate, resulting in a 20% increase in gasification area equipment costs, which is mainly due to the primary gasifier cyclone cost. The gasifier cost, which is based on the wood feed rate, is not affected by changes in the raw gas volume flow rate. A similar increase is noted in the tar cracker. The cost estimates for cyclones and tar crackers are based on the inlet stream volume flow rate. Because of the high H₂ content in raw syngas, the volumetric flow rate is 58.6 Nm³ compared to 45.8 Nm³ in the *Base Case*. The raw syngas volume flow rate increases about 28%. Equipment costs in the steam reformer section increases because of increased flow to the reformer from the additional CO₂ and higher overall reforming duty. However, the lower methane level in the syngas leaving the steam reformer reduces the equipment costs in the alcohol synthesis section by about 17%. The steam turbine system equipment costs are reduced by 10% because of the lower steam rate. Net power produced by the integrated process is reduced as a result of the increased air, raw syngas, and CO₂ compressor power requirements and decreased steam flow available for power generation.

This case increases the selling price cost over the *Base Case* by \$0.20/gal. Approximately half of this increase is the result of lower net power generation in the steam turbines and, thus, a lower electricity credit. About another quarter of the increase can be attributed to increased capital related costs.

Model Limitations. The main cost limitation of the model is that the gasifier vessel cost is based on the dry biomass feed rate and does not capture the effect of gasifier vessel size changes needed to accommodate process changes such as increased steam injection. However, this type of effect is captured in the cyclone separators as their costs scale with the gas flow rate. The tar concentration may be lower than that calculated by the correlation (Section 2.1.1) at *Case A1* conditions. Finally, the results are somewhat confounded in that the syngas is not at the appropriate H₂/CO ratio for the synthesis step in either *Case A1* or the *Base Case*, and there is no suitable correlation to determine the gas composition at an intermediate set of gasifier conditions.

Analysis. Regardless of the gasifier equipment sizing and costing limitations, it is clear that changing the reactor conditions to alter the H₂:CO ratio has a significant impact on the cost of producing ethanol, and therefore, its selling price. In *Case A1*, changing the H₂:CO ratio from 0.57 to 1.7 increased the ethanol price by about 15%. However, much of cost increase is due to the requirement for higher CO₂ injection to the reformer as well as increased gas flows (specifically steam and CO₂ flows) to the gasifier, cyclone separators, scrubber, and cooled raw gas compressors. It may be that an intermediate set of operating conditions between the *Base Case* and *Case A1* that produce a raw gas that more closely matches the synthesis H₂:CO ratio of 1.2, might require less steam to the gasifier, resulting in lower overall processing costs. Alternatively, if the conversion, selectivity, and productivity of the alcohol synthesis reactor are found to be insensitive to the H₂:CO ratio, the costs required to adjust the H₂:CO ratio in the raw gas can be avoided.

3.1.3 Case A2. Gasifier Pressure Increases to 10 Atm

Case A2 investigated the effects of increasing the gasifier pressure. This case is motivated by the absence of data for an indirectly heated gasifier operating at elevated pressure, and the apparent

preference to operate directly heated gasifiers at elevated pressure. For *Case A2*, the gasifier pressure is increased to 147 psi (10 atm). The gasifier correlation in Section 2.1.1 is used in this case. Because the gasifier operates at high pressure, a lock-hopper feeder system is used to feed the dried wood into the gasifier. Pressurized CO₂ recovered from the gas purification and conditioning section of the plant is used in the lock hopper as the feedstock carrier. The CO₂ is fed at a flow rate of 0.03 lb of CO₂/lb of dried wood and compressed to 150 psi. The gasifier combustion zone also operates at high pressure. The air is compressed to 150 psi using a multistage intercooling compressor, and then sent to the combustion zone. Compared to the *Base Case*, the raw syngas is at higher pressure; thus, the downstream processes are modified to match the pressure change.

Performance Results. Compared to the *Base Case*, the raw syngas composition modeled in *Case A2* has a higher CO₂ content because extra CO₂ from the gas purification process is used as the lock-hopper feed gas and is sent with the dried wood to the gasifier. The compositions for the other components and the H₂:CO ratio are very close to the *Base Case*. Using CO₂ as feed gas also leads to a higher scrubbed dry raw gas flow rate.

Case A2 has the same CO₂ feed rate to the steam reformer as the *Base Case*. The steam injection is increased to reach the required H₂:CO ratio. The higher CO₂ content in the raw syngas and the higher steam:feed ratio results in greater methane conversion and a higher overall flow rate of clean syngas. Compared to the *Base Case*, *Case A2* has a higher final product yield and higher carbon efficiency. These improvements are attributed to a greater fraction of the methane in the raw gas being converted to CO and H₂ in the steam reformer.

The power consumption results show that increasing the gasification pressure leads to a very small change in net power output compared to the *Base Case*. In *Case A2*, power consumption for the char combustor air compressor is much higher than that of *Base Case* as is the power needed for compressing the lock-hopper CO₂. However, these power increases are balanced by the lower compression power needed to boost the raw syngas pressure.

Economic Effects. Because of the increased gasifier pressure, the installed cost for the feed preparation and drying section increases by \$11.2 million. The installed cost for the gasifier and cyclone separators increases by \$4.2 million, whereas the power needed for raw syngas compression decreases by \$18.7 million. The total project investment for *Case A2* is lower than that for the *Base Case* by \$4 million, mainly because of the lower cost for syngas compression. Overall, the ethanol selling price decreases by about 7% from the *Base Case* because of the reduced capital charges and increased ethanol yield.

Model Limitations. The syngas composition correlations (Section 2.1.1) may not accurately reflect high-pressure operation. The correlations were based on experimental data for near atmospheric conditions and do not have a correction for high-pressure operation. However, the cost estimate for the gasifier vessel does reflect the effect of operating at higher pressure.

Analysis. Although pressure increases the gasifier section cost, the higher raw gas pressure reduces the cost for syngas gas compression. Overall, the estimated ethanol selling price is lower than that of *Base Case* and appears to have a positive effect. Gasification above 10 atm with this type of gasifier requires further research.

3.1.4 Case A3. Methane/Ethane are not Reformed and Clean Syngas Pressure Changed to Maintain H₂/CO Partial Pressures

Case A3 investigates the effects of not reducing the methane and ethane content in the syngas. This case focused on determining the effect of eliminating the capital and operating costs associated with a steam reformer against the expected loss of mixed-alcohol yield. The total pressure of clean syngas to the synthesis reactor is varied to maintain the same H₂ and CO partial pressures. The steam reformer in the *Base Case* is replaced by a WGS reactor, which is used to adjust the H₂:CO ratio to match the synthesis requirement of 1.2:1. Methane and ethane are considered to be inert in the WGS reaction. Medium-pressure steam in a steam:CO ratio of 3:1 is used in the WGS process. After shift, the syngas is compressed to 2096 psi (2091 psi alcohol synthesis reactor pressure) to match the partial pressure of CO and H₂ in the *Base Case*.

Performance Results. *Case A3* has the same raw syngas composition as the *Base Case*. The clean syngas molar flow rate is less than that of *Base Case* because none of the methane and ethane in the scrubbed gas is steam reformed to CO and H₂, resulting in a net decrease of the total moles of dry gas (see Equation 2.4). This, in turn, reduces the yield of mixed alcohol products to less than 16% of the *Base Case*.

While the syngas pressure must be increased to achieve the same H₂ and CO partial pressures in the clean syngas, the lower flow rate of clean syngas compensates so that the compressor power consumption is about 12% less than that of the *Base Case*. Because the methane and ethane do not react in the alcohol-synthesis reactor, they build up to higher concentrations in the recycle streams in alcohol synthesis process, increasing the total flow to the synthesis reactor. While the recycle compressor duty does increase significantly, it is such a small value relative to the rest of the power needs that it does not impact the net power consumption. Elimination of the CO₂ and air compressors for the steam reformer reduces the overall compression power demand. Also, more gas must be purged from the alcohol synthesis recycle loop to maintain an acceptably low concentration of hydrocarbon impurities in the alcohol-synthesis reactor. The purged gas is sent to the steam cycle for power generation. This increases the steam capacity requirements of the purge gas-fired superheater and the gas-fired boiler, resulting in an increase in the air compressor power requirements for the boiler and superheater. However, 10 MW more power is generated, which is nearly double the power generated in the *Base Case*.

Economic Effects. The elimination of the steam reformer also eliminates the CO₂ and air compressor costs and replaces the cost of the steam reformer with a less expensive WGS reactor. The clean syngas compressor cost is also lower than that of the *Base Case* because of the lower syngas flow. The installed equipment cost for mixed-alcohol synthesis is 14% higher than the *Base Case* because of a greater recycle syngas flow to the synthesis reactor and the higher synthesis pressure of 2096 psi. Because more steam and electricity are generated in this case, the equipment costs for this case also increase. As a result the total project investment for *Case A3* is almost \$7mm less than for the *Base Case*.

The yield loss causes reduced byproduct credits that are partially offset by a higher electricity credit. The net variable cost of *Case A3* is about 9% higher than that for the *Base Case*. Overall, the ethanol per gallon cost is \$0.55/gal higher for *Case A3*. This is attributed to the 16% lower production rate of ethanol, which in turn is attributed to the lower yield of H₂ and CO in the clean syngas because the methane was not steam reformed.

Model limitations. No significant limitations were noted for this case.

Analysis: Although eliminating the steam reformer and associated compressors reduces the capital cost and power generation revenue is increased, the reduced yield of mixed alcohols results in a higher ethanol cost on a per gallon basis. Thus, the reduction in mixed alcohol yields more than offsets the economic benefits of eliminating the steam reformer, thus resulting in a higher unit cost of ethanol.

3.1.5 Case A4. Methane/Ethane is Assumed to be Inert and Clean Syngas Pressure Unchanged

Case A4 also investigated the effect of not steam reforming the syngas to remove methane and ethane. Unlike *Case A3*, this case does not adjust the synthesis reactor partial pressure of H₂ and CO to match that of the *Base Case*. This case was conducted to differentiate between the effects of the alcohol-synthesis reactor pressure increase of *Case 3A* and the cost savings of eliminating the steam reformer.

Performance Results. The only difference between *Case A4* and *Case A3* is the alcohol-synthesis pressure. The clean syngas in *Case A4* is compressed to 2000 psia, which is the same as in the *Base Case*, whereas the clean syngas in *Case A3* is compressed to 2096 psi. The partial pressure of CO and H₂ in *Case A4* is lower than that of the *Base Case* because of the large amount of methane and ethane in the syngas.

Power consumption for the clean syngas compressor and the boiler and superheater air compressor for *Case A4* is slightly lower than that in *Case A3* because of the slightly lower synthesis pressure in *Case A4*. This results in a small increase in the net power production for *Case A4*.

Economic Effects. Compared to *Case A3*, the differences in the variable costs are very small, and are caused by the modest decreases in power consumption for the syngas compressor, boiler, and superheater air compressors. The installed equipment cost for the alcohol synthesis equipment in this case is lower than that of *Case A3* because of the lower reactor pressure requirement. However, the equipment cost savings and the reduced variable costs are still insufficient to overcome the effects of reduced higher alcohol yields. As a result, the selling price for ethanol is well above that for the *Base Case*.

Model Limitations. *Case A4* has lower CO and H₂ partial pressures in the alcohol-synthesis reactor than in the *Base Case*. The lower partial pressure would normally be expected to lower the CO conversion per pass resulting in lower higher alcohol yields and higher gas-recycle rates. The CO conversion per pass in the current model is constant and does not reflect the impact of changed CO and hydrogen partial pressures. Both effects would make the selling price higher than estimated for this case.

Analysis. Similar to *Case A3*, not converting the methane and ethane to H₂ and CO decreases the system carbon efficiency and, thus, leads to a higher production cost. In *Case A4*, the synthesis pressure is assumed to be unchanged, while in *Case A3*, the synthesis pressure is increased to match the *Base Case* H₂ and CO partial pressures. Comparing these two cases, although the two cases have the same carbon efficiencies and final product yields, the cost for *Case A4* is lower because of the lower synthesis pressure. Therefore, the lower process pressure would lower the system cost.

3.1.6 Case A5: Tar Production is Assumed to be Double that of Base Case

Case A5 examines the effects of doubling the tar content in raw syngas on the final product yield and cost. This case is motivated by uncertainty in the reported tar concentrations in the raw gas from various gasifiers because of differences in the methods used to quantify them. It is not intended to suggest increasing or decreasing the tar content intentionally.

In this case, the char production rate is assumed to remain the same. To increase tar production, the total mass flow rate of the gas components in the raw gasifier product gas are decreased, and the carbon content of the char is adjusted to maintain the overall mass balance. The molar fraction for each gas component, as estimated by correlations developed by Spath et al. (2005), remained the same with respect to each other because the temperature used in the correlations is the same as the *Base Case*. However, the absolute rate for each gas component is decreased to account for the increased concentration of tar in the raw gas.

Performance Results. As shown in Table 3.1, the concentration of tar in the syngas is double that of the *Base Case*. Because tar production increases, the hydrogen and carbon components in the tar increase. These components are provided to the tar by uniformly reducing the concentrations of the non-condensable gases, such as H₂, CO, CO₂, and CH₄, in the raw gas, and exchanging a portion of the carbon in the char for oxygen. This maintains a constant char mass flow rate and overall carbon, hydrogen, and nitrogen atom balances. Thus, the total mass flow rate of char stays the same as the *Base Case*, while the carbon component in the char decreases. The net result is that the total carbon in the raw gas associated with the gases and the tar has increased in *Case A5* compared to the *Base Case*.

The majority of the tar is converted into H₂ and CO in the tar cracking unit. As a result, the scrubbed syngas on a dry basis for *Case A5* has more H₂ and CO than that of the *Base Case*. The scrubbed syngas is further sent to the steam reformer to convert part of the methane and remaining tar into CO and H₂. The clean syngas flow rate of *Case A5* is higher than that of the *Base Case* because more H₂ and CO is produced from the higher tar content. The increased H₂ and CO in the syngas leads to a 2% increase in the ethanol yield.

The power consumption of raw syngas compressor of *Case A5* is greater than that of the *Base Case* due to higher syngas flow. Higher syngas flow in the clean syngas also leads to more off-gas sent to the steam cycle for power generation. The steam turbine power generation of *Case A5* is higher than the *Base Case*, and the net power output of *Case A5* is slightly higher than the *Base Case*.

Economic Effects. Table 3.2 summarizes the equipment costs for *Case A5*. Increasing tar production increases the cost of the gasifier and syngas cleaning and conditioning sections of the plant by less than 2%. *Case A5* has only a slightly higher equipment cost as the *Base Case*.

Because of higher yields of ethanol and the higher alcohol byproducts, plus increased power output, the variable costs for *Case A5* are lower than that of *Base Case*. The ethanol price decreased approximately \$0.05/gal as compared to the *Base Case*, mainly because of the increased mixed alcohol yield.

Model Limitations. A key limitation in this case is the manner in which tar concentration is achieved. Here, the gaseous components are a source of a portion of the tar, with the char being a second source. Consequently, the composition of the char changes so that it contains more oxygen. This is not necessarily the correct model for this phenomenon; although under the high-temperature gasifier

conditions, the tar that is cracked likely produces both char and gas (although cracking decreases tar, which is the opposite of this case). Whether or not the char loses oxygen in the process is subject to debate. However, considering the modest effect of doubling the tar concentration on the ethanol selling price, it is unlikely that a more accurate method for increasing the tar concentration would result in a significantly different result. Another limitation is that the gasifier vessel cost is based on the dry biomass feed rate and does not reflect the effects of tar production increase on the vessel size or other design specifications. In addition, the tar reforming cost is calculated from the inlet syngas volume flow rate, which does not capture the equipment size increase needed to compensate for the increased residence time that may be required to reform the extra tar. These limitations, which are not expected to have major effects on the selling price, would offset some of the selling price decrease.

Analysis. Overall, the decrease in the ethanol selling price due to a doubling of the tar content in the raw gas is fairly modest. The primary reason for this is the increased ethanol yield because the carbon content is higher in the syngas and lower in the char. Two conclusions can be derived from this case. First, the fact that there is more tar in the gas is not detrimental and, in fact, may be modestly beneficial to the overall process economics as long as the tar can be efficiently reformed to gas. Second, increasing the inventory of H₂ and CO in the clean syngas, whether by decreasing the amount of carbon in the char or by greater reforming efficiencies for the tar (or other hydrocarbons such as methane), has a very significant impact on the ethanol selling price, because of the increase mixed-alcohol yields.

3.1.7 Case A6: Tar Production is Assumed to be Half that of the Base Case

Case A6 is a companion to *Case A5* in that it examines the effect of decreasing the tar content in raw syngas by a factor of two. Using the same methodology used in *Case A5*, the char production rate remains the same, while the total mass flow rate of the gas components in the raw gasifier product gas is increased, and the carbon content of the char is adjusted to maintain the overall mass balance. The molar fraction for each gas component, estimated by the correlations developed by Spath et al. (2005), remain the same with respect to each other because the temperature used in the correlations is unchanged in this case, when compared to the *Base Case*. However, the absolute concentrations increase to account for the decreased concentration of tar in the raw gas.

Performance Results. As might be expected, the effects of halving the tar production rate on the overall process were similar to those in *Case 5A*, but in the opposite direction and with approximately half the impact because the quantity of the tar decrease in this case is one-half the quantity of tar increase in *Case 5A*. With less dry clean syngas produced, the yield of mixed alcohols is similarly reduced. The power consumptions of the raw gas and clean gas compressors for *Case A6* are lower than that of *Base Case*. Because less syngas is used for synthesis, less off-gas is sent to the steam cycle for power generation. The steam turbine power generation for *Case A6* is lower than that of the *Base Case*; therefore, the net power output of *Case A6* is almost the same as the *Base Case*.

Economic Effects. *Case A6* requires a slightly lower capital investment than that of the *Base Case*. The costs for the gasifier and tar reformers are almost the same as for the *Base Case*. Because of the model limitation, the cost of the tar reformer may be overestimated because less tar is produced in *Case A6*.

Because the final product yield is slightly lower, the total variable credit for this case is lower than that of the *Base Case*. The production cost is close to that of the *Base Case*; therefore, the effect of lowering the tar production on cost is minor at best.

Model Limitations: The limitations for this model are similar to those for *Case A5*.

Analysis. Lowering the tar production to half that of the *Base Case* results in a very slight increase in cost. The main reason is that original tar production is already very small, thus lowering it by half causes about half the magnitude of the changes that occurred when the tar concentration was doubled in *Case 5A*.

3.2 Directly Heated Gasifier Scenarios

Seven cases are considered for the mixed-alcohol synthesis plant based on the directly heated gasifier:

Base Case: The raw gas composition is from correlations developed by Eggeman (2005) based on experimental data reported in Evans et al. (1988) using the Gas Technology Institute's 12 ton/day process research unit.

Case B1: The gasification pressure is decreased to 20 psig, compared to 330 psig for the *Base Case*. The syngas is assumed to have the same composition as that predicted at higher pressure.

Case B2: The gasification pressure is changed to 20 psig. The syngas composition is adjusted by extrapolating the gasifier correlations to 20 psig.

Case B3: The steam reformer is replaced by a simple shift reactor. Methane and ethane are assumed to be inert in the synthesis step. The total syngas pressure is increased to maintain the same H₂ and CO partial pressures as in the *Base Case*.

Case B4: The same assumptions as used in *Case A3* apply, except that the total syngas pressure is unchanged from the *Base Case*.

Case B5: The tar production rate is double that of the *Base Case*.

Case B6: The tar production rate is one-half of that in the *Base Case*.

Table 3.4 summarizes the operating conditions and performance results for the directly fired pressurized gasifier cases. Tables 3.5 and 3.6 summarize the associated capital and operating costs, respectively. These cases are similar to the cases examined for the indirectly heated gasifier scenarios. They are considered mainly to identify any instances where the type of gasifier has an influence on the overall economics.

3.2.1 Base Case

The *Base Case* uses the process configurations shown in Figures 2.2, 2.3, 2.4, 2.5, and 2.7. The correlation model developed from the data of Evans (1988) is used to estimate the raw syngas compositions. Selected key operating parameters for these unit operations are:

- Gasifier Pressure – 330 psia
- Gasifier Temperature – 871°C (1600°F)
- Alcohol synthesis Reactor Temperature – 299°C (570°F)
- Alcohol Synthesis Reactor Pressure – 1995 psia
- Alcohol Synthesis Reactor feed Gas H₂:CO ratio – 1.2.

The alcohol product-distribution, CO-conversion, and product-selectivity assumptions for the alcohol synthesis reactor are similar to those used by Aden et al. (2005). Additional details on the base process flow sheet and modeling results are provided in Appendix C.

Table 3.4. Performance Results for Directly Heated Gasifier Based System Models

Case	Base	B1	B2	B3	B4	B5	B6
		Decreased Gasifier Pressure (Syngas Unchanged)	Decreased Gasifier Pressure (Syngas Changed)	No Steam Reformer Const. H ₂ , CO partial Pressures	No Steam Reformer Constant Total Pressure	Double Tar Conc.	One-Half Tar Conc.
Case Description	Base						
Gasifier Pressure, psi	330	20	20	330	330	330	330
Gasifier Temperature, °F	1600	1600	1600	1600	1600	1600	1600
Raw Gas Compositions, Mol%							
Hydrogen	15.4	15.6	9.9	15.4	15.4	15.3	15.5
Carbon monoxide	15.1	15.3	21.9	15.1	15.1	14.6	15.2
Carbon dioxide	26.3	25.4	17.2	26.3	26.3	25.8	26.4
Methane	11.3	11.5	8.5	11.3	11.3	11.1	11.4
Water	29.7	30.1	38.5	29.7	29.7	30.6	29.9
Benzene	0.93	0.94	1.3	0.93	0.93	1.3	0.47
Naphthalene	0.26	0.27	0.31	0.26	0.26	0.38	0.13
C ₂ ⁺	0.9	0.9	2.4	0.9	0.9	0.8	0.9
H ₂ :CO ratio	1.02	1.02	0.45	1.02	1.02	1.04	1.02
Char Production, lbm/hr	7510	7510	4196	7510	7510	1340	13743
Scrubbed (dry) raw gas flow rate, lbmol/hr	11336	11220	11200	11840	11840	12285	10394
Alcohol synthesis Pressure, psi	1995	1995	1995	2159	1995	1995	1995
Alcohol Synthesis Temperature, °F	570	570	570	570	570	570	570
Clean Syngas Composition, Mol%							
Nitrogen	0.3	0.4	0.3	0.3	0.3	0.3	0.3
Hydrogen	50.7	51.3	50.3	47.4	47.4	50.4	51.2
Carbon monoxide	43.2	42.5	42.9	39.3	39.3	43	43.3
Carbon dioxide	0.2	0.2	0.2	0.5	0.5	0.2	0.2
Methane	5.5	5.6	6.3	12.1	12.1	6.1	4.9
Water	0	0	0	0	0	0	0
C ₂ ⁺	0	0	0	0.3	0.3	0	0
H ₂ :CO ratio	1.17	1.21	1.17	1.21	1.21	1.17	1.18
Clean Syngas Flowrate, lbmol/hr	10351	10264	10687	8807	8807	11176	9502
Final Products, MM gal/yr							
Ethanol	45.4	43.7	46.5	34.5	34.5	47.4	42.4
Propanol	9.2	8.8	9.4	7.0	7.0	9.6	8.6
Butanol	3.9	3.8	4	3.0	3.0	4.1	3.7
Pentanol	1.9	1.9	2	1.5	1.5	2	1.8
Total	60.4	58.1	61.9	45.9	46.0	63.2	56.5
Carbon Efficiency, %	30.1	29	30.9	22.9	22.9	31.2	28.1
Power Consumption, MW							
Air separation unit	-8.6	-7.7	-7.7	-8.6	-8.6	-8.6	-8.6
Dryer Air Fan	-0.2	-0.2	-0.4	-0.2	-0.1	-0.2	0
Lock hopper gas compressor	-0.2	0	0	-0.2	-0.2	-0.2	-0.2
Air compressor	-0.5	-0.9	-0.5	-0.5	-0.5	-0.2	-1.7
Raw syngas compressor	-1.9	-22.4	-23.6	-2	-2	-2	-1.7
Reformer air compressor	-1.3	-1.3	-1	0	0	-1.3	-1.3
CO ₂ compressor	-0.9	-0.9	-0.8	-2.9	-2.9	-0.9	-0.9
Clean syngas compressor	-8.3	-8.2	-8.5	-7.7	-7.3	-8.9	-7.1
Recycle compressor	-0.2	-0.2	-0.2	-0.2	-0.2	-0.2	-0.2
Boiler air compressors	0	0	0	-2.2	-2.1	0	0
misc	-8	-8	-8	-8	-8	-8	-8
Power Production, MW							
Steam turbines	31.5	33.5	29.2	54.8	54.6	31.7	32.2
Net Power Output, MW	1.4	-16.3	-21.5	22.4	22.9	1.3	2.5

Table 3.5. Equipment and Capitals Costs for Directly Heated Gasifier Based System Models

Case	Base	B1	B2	B3	B4	B5	B6
Case Description	Base	Decreased Gasifier Pressure (Syngas Unchanged)	Decreased Gasifier Pressure (Syngas Changed)	No Steam Reformer Const. H ₂ , CO partial Pressures	No Steam Reformer Constant Total Pressure	Double Tar Conc.	One-Half Tar Conc.
Installed Equipment Costs:							
Air Separation Unit	22.5	22.5	22.5	22.5	22.5	22.5	22.5
Feed prep & drying	27.6	24.4	24.4	27.6	27.6	27.6	27.6
Gasifier & Cyclones	106.2	106.1	106.2	106.2	106.2	106.5	105.7
Tar cracker	4.6	4.6	4.5	4.6	4.6	4.5	4.8
Gasifier heat recovery	0.6	0.5	0.5	0.6	0.6	0.6	0.6
Syngas compression	1.6	15.7	15.0	1.7	1.7	1.7	1.6
Sulfur removal	3.8	3.8	3.7	3.8	3.8	3.8	3.7
Steam Reformer (SR)	17.0	16.8	14.5	0.0	0.0	16.9	16.9
Water Gas Shift (WGS)	0.0	0.0	0.0	4.0	4.0	0.0	0.0
SR or WGS Heat Recovery	4.1	3.7	3.5	0.8	0.7	3.8	3.7
SR or WGS CO ₂ compressor	0.0	0.0	0.0	8.0	8.0	0.0	0.0
Amine CO ₂ removal	20.1	19.7	19.3	21.9	21.9	20.2	20.0
Clean syngas compression	4.1	4.0	4.1	3.9	3.7	4.3	3.8
Mixed alcohols synthesis	25.3	24.1	27.0	33.6	30.9	21.9	26.8
Mixed alcohol recycle	15.0	14.9	15.3	13.0	13.0	15.0	14.6
Mixed alcohol separations	19.8	19.8	20.5	16.9	16.9	20.6	19.7
Steam sys & power gen	18.4	18.4	18.4	22.3	22.3	18.4	18.4
Remainder OSBL	5.3	4.5	4.5	4.5	4.5	4.5	4.5
Total Installed, mm\$	296.0	303.6	304.1	295.9	292.7	292.7	295.0
Total Indirect, mm\$	151.0	154.8	155.1	150.5	149.3	149.3	150.4
Total Capital Inv, mm\$	447.0	458.4	459.3	446.4	442.0	442.0	445.4

Table 3.6. Operating Costs for Directly Heated Gasifier Based System Models

Case	Base	B1	B2	B3	B4	B5	B6
Case Description	Base	Decreased Gasifier Pressure (Syngas Unchanged)	Decreased Gasifier Pressure (Syngas Changed)	No Steam Reformer Const. H ₂ , CO partial Pressures	No Steam Reformer Constant Total Pressure	Double Tar Conc.	One-Half Tar Conc.
Variable Costs, \$mm/y							
Hybrid Poplar Chips	25.330	25.330	25.330	25.330	25.330	25.330	25.330
Olivine makeup	1.767	1.767	1.767	1.767	1.767	1.767	1.767
Ash disposal	1.003	1.003	1.003	1.003	1.003	1.003	1.003
Misc Chemicals	2.269	2.184	2.326	1.724	1.726	2.372	2.121
Tar Reformer Catalyst	0.454	0.437	0.465	0.345	0.345	0.474	0.424
Mixed Alcohols Catalyst	0.142	0.135	0.151	0.182	0.182	0.121	0.150
Wastewater treatment	1.134	1.223	0.991	0.813	0.814	1.136	1.214
Cooling water	2.310	2.550	1.922	1.806	1.808	2.336	2.478
Natural gas	0.000	0.000	0.000	0.000	0.000	0.237	0.000
Electricity	-0.739	8.659	11.402	-11.911	-12.098	-0.679	-1.349
Propanol + Credit ^a	-62.786	-60.416	-64.406	-47.892	-47.922	-65.654	-58.698
Total Variable, \$mm/yr	-29.116	-17.128	-19.047	-26.832	-27.044	-31.555	-25.559
Fixed Costs, \$mm/yr	20.021	20.399	20.426	20.006	19.856	19.855	19.966
Depreciation (5%/yr), \$mm/yr	22.352	22.921	22.963	22.321	22.102	22.101	22.268
Gen & Admin, \$mm/yr	6.355	6.971	7.088	5.686	5.634	6.329	6.311
ROI (10%/yr), \$mm/yr	44.704	45.843	45.925	44.643	44.204	44.203	44.536
EtOH Production, mmgal/yr	45.377	43.679	46.523	34.488	34.527	47.450	42.421
Total Variable, \$/gal EtOH	-0.642	-0.392	-0.409	-0.778	-0.783	-0.665	-0.603
Fixed Costs, \$/gal EtOH	0.441	0.467	0.439	0.580	0.575	0.418	0.471
Depreciation, \$/gal EtOH	0.493	0.525	0.494	0.647	0.640	0.466	0.525
Gen & Admin, \$/gal EtOH	0.140	0.160	0.152	0.165	0.163	0.133	0.149
ROI, \$/gal	0.985	1.050	0.987	1.294	1.280	0.932	1.050
Est. Selling Price \$/gal	1.417	1.809	1.663	1.909	1.875	1.284	1.592

3.2.2 Case B1. Gasifier Pressure Decreases and Syngas Compositions are Unchanged

Case B1 examines the effect of decreasing the gasifier pressure on system performance and cost. The syngas compositions are assumed to be the same as those used in the *Base Case* for a 330 psia operating pressure. Decreasing the gasifier pressure to 20 psia leads to several modifications to the overall process. The CO₂ pressurized lock hopper used in the *Base Case* for sending feedstock into gasifier is no longer needed. Low-pressure steam at 35 psi replaces high-pressure steam injected into the gasifier. The oxygen compressor in the air separation unit is also no longer needed. Because low-pressure syngas is generated, the raw syngas compressor is changed from a single stage to a multiple stage unit with intercooling to compress raw syngas from 15 to 417 psi.

Performance Results. In *Case B1*, the raw syngas compositions are assumed to be unchanged at the lower gasifier pressure and thus this case has the same H₂:CO ratio and char production as the *Base Case*. However, the CO₂ content in the raw syngas is lower than that of *Base Case* since there is no lock hopper pressurized by CO₂. Thus, all other syngas components are slightly higher than the *Base Case*. For the same reason, the flow rate of scrubbed dry raw syngas is lower than that of *Base Case*.

Case B1 has the same gasifier steam injection rate as the *Base Case*. However, because of the lower CO₂ content, the WGS reaction produces a lower CO content and a higher H₂ content in the clean syngas, resulting in a slightly higher H₂:CO ratio. The clean syngas flow rate and CO concentration in this case is lower than that of the *Base Case*, thus resulting in reduced mixed alcohol yields.

The differences in power consumption stems from two processes: 1) the air separation unit and 2) the raw syngas compressor. Because the gasifier pressure is low, no O₂ compressor is needed in the air separation unit, therefore, the net power consumption for the unit is less when compared to that in the *Base Case*. However, the raw syngas compressor power consumption is much greater than that of the *Base Case* because the raw syngas compressor now must increase the syngas pressure from 15 to 417 psi, while in *Base Case*, the pressure change differential is less (i.e., from 324 to 417 psi). The amount of power generated by the steam turbine in this case is higher than in the *Base Case* because low-pressure steam is used in the gasifier, while in the *Base Case*, high-pressure steam is used. The net power output is significantly reduced in *Case B1* because of the increased power requirements of the raw syngas compressor is so much greater than the increased power generation by the high-pressure steam turbine.

Economic Effects. Decreasing the gasifier pressure leads to a decrease in the gasification capital costs mainly because the lock-hopper compressor is eliminated from the process. However, the raw gas compressor cost increases nearly sevenfold. The total installed cost for *Case B1* is about 3% higher than that of the *Base Case*. The large amount of power needed for the raw syngas compressor results in a switch from export power to import power. The increased variable and capital costs, along with a decreased ethanol yield, results in an increased ethanol selling cost of \$0.39/gal.

Model Limitations. The cost model for the high-pressure, directly heated gasifier (based on Hamelinck and Faaij [2002]) is used in this case for estimating the low-pressure gasifier cost. Thus, the impact of the pressure decrease on the gasifier cost is not considered because of a lack of reference data. In general, lowering the gasification pressure should lower the capital cost for the gasifier. However, it is likely that a low-pressure gasifier will require a longer residence time, thus resulting in a larger size. This may eliminate the savings from reducing the reactor wall thickness required for high-pressure operation.

Another limitation is that the air separation unit cost is a single value that includes the price of an O₂ compressor. No separate cost model was developed for the O₂ compressor. Therefore, the installed cost for the air separation unit is overestimated for this case. This limitation can be solved by developing a more detailed air separation unit cost model that includes the cost for each main component. However, the impact of this limitation is minor compared to other costs in the system. Lastly, this case assumes that the raw syngas composition is unaffected by the gasifier operating pressure. This limitation is addressed in *Case B2*.

Analysis. Assuming that the syngas composition is unchanged, decreasing the gasifier pressure leads to higher production costs. This is mainly the result of higher capital and operating costs for the raw syngas compressor and decreased revenue from export power that cannot be compensated for by cost savings in feedstock feeding and O₂ compression.

3.2.3 Case B2. Gasifier Pressure Decreases and Syngas Compositions are Changed

Case B2 also examined the effects of decreasing the gasifier pressure on system performance and cost, but with allowances for raw syngas composition changes with pressure. The gasifier pressure is reduced to 20 psi, while maintaining the *Base Case* temperature (i.e., 1600°F). The syngas composition is adjusted for the lower pressure by using the correlations published by Eggeman (2005). Because the gasifier operates at low pressure, the pressurized lock hopper and the multiple-stage oxygen compressor is eliminated and low-pressure steam (35 psi) is used. The raw syngas compressor is changed to a multiple-stage compressor with intercooling to meet the raw syngas compression requirements.

Performance Results. The raw syngas of *Case B2* has less H₂, CO₂, and CH₄, but more CO, H₂O, tar, and C₂₊ than that of the *Base Case*. *Case B1* also has much lower H₂:CO ratio and the char production in this case is about half. The scrubbed dry raw syngas flow rate is comparable to that of the *Base Case*, but the total CO and H₂ flow rates in the raw syngas is higher. Because the raw syngas in *Case B2* has a much lower H₂:CO ratio than that in the *Base Case*, more steam is used in the steam reformer to increase the H₂:CO ratio to ~1.2. The clean syngas flow rate is higher than that of the *Base Case*, leading to a higher mixed alcohol yield.

The electric power generation for this case is lower than that of both *Case B1* and the *Base Case*. As in *Case B1*, the power consumption of the air separation unit is lower than that of *Base Case* because the oxygen compressor is eliminated. However, the power consumption of the raw syngas compressor is much higher than that of *Base Case* because of the low pressure of the inlet raw syngas. Power consumption for the raw syngas compressor also is slightly higher than that of *Case B1* because the raw syngas has more water and thus a higher flow rate than in *Case B1*. The steam turbine power generation is lower than both the *Base Case* and *Case B1*. Although low-pressure steam is used in the gasifier, the increase in high-pressure steam consumption in the steam reformer reduces the available steam used for power generation. Reduced char production in the gasifier reduces the heat from the exhaust gas of the combustor; therefore, a greater fraction of the purge gas from the alcohol synthesis process is used in the feed stock dryer, leaving less fuel gas for the gas turbine power generation.

Economic Effects. The total capital investment for *Case B2* is almost the same as for *Case B1*, with higher equipment costs for alcohol synthesis and purification and lower equipment costs for raw syngas compression, purification, and conditioning. The total decrease in power-generation credits for *Case B2*

relative to *Case B1* are more than offset by a significant increase in byproduct credits attributed to the higher mixed alcohol yields. However, the increased byproduct credits do not offset the increased raw syngas compression costs for this case. The net result is a production cost that is higher than the *Base Case*.

Model Limitations. The cost estimation limitation for the low-pressure gasifier and the air separation unit analyzed in *Case B1* also applies to this case. The syngas compositions were estimated using the correlations developed by Eggeman (2005), which covered a pressure range from 84 to 345 psia. It was assumed that this correlation could be extrapolated down to 20 psi.

Analysis. *Case B2* showed that while the effects of changing pressure on the composition of the gas had a beneficial effect on the ethanol selling price, the impact of having to pressurize the raw syngas from 20 to 417 psia instead of from 330 to 417 psia is the dominant factor affecting the selling price as was shown in the previous case. Thus, it appears that high-pressure operation of the gasifier is the preferred case.

3.2.4 Case B3. Methane/Ethane are not Reformed and the Clean Syngas Pressure is Changed

Case B3 investigated the effects of not reducing the syngas methane and ethane concentrations by steam reforming to determine the effect of eliminating the capital and operating costs of a steam reformer against the expected loss of mixed alcohols yield. The total pressure of the clean syngas was increased to maintain the same H₂ and CO partial pressures as in the *Base Case*. A reverse WGS reactor is used in place of the steam reformer to adjust the H₂:CO ratio in the scrubbed gas to the desired synthesis gas ratio of 1.2:1. The methane and ethane are inert in the reverse WGS reaction. The reverse WGS reactor is assumed to be similar to a standard high-temperature shift reactor, except that compressed CO₂ is substituted for steam and the reactor outlet temperature is lower than the inlet temperature. The inlet temperature is limited to 725°F to keep the temperature within the upper bounds of a standard WGS reactor. The clean syngas pressure is increased to 2164 psi (2159 psig in the alcohol synthesis reactor) to maintain the same partial pressure of H₂ and CO as the *Base Case*. Because methane and ethane are not reformed, the synthesis gas recycle loop purge gas contains larger amounts of light hydrocarbons that are then used for power generation. A gas-fired boiler and superheater are added into the steam cycle to combust the extra purge gas and generate high-pressure steam for power generation.

Performance Results. The raw syngas compositions for *Case B3* are the same as for the *Base Case* because there are no modifications to the gasifier. The clean syngas from the CO₂ removal unit has a much lower flow rate than that in the *Base Case* because no steam reforming of methane and ethane in the scrubbed syngas to H₂ and CO occurred, which would have increased the total molar flow rate of the clean syngas. The reduced flow of CO and H₂ resulted in a 24% reduction in the mixed alcohol yield compared to that for the *Base Case*.

While the clean syngas must be compressed to a higher pressure to maintain the same syngas H₂ and CO partial pressures as in the *Base Case*, the lower syngas flow rate results in a 7% decrease in the compressor power requirements. However, the lower compression duty for the clean synthesis syngas is offset by the higher compression duty for the larger synthesis recycle gas flow.

Replacing the steam reformer with a reverse shift reactor slightly increases the power demand. The steam reformer only needed air blowers for the burners, while the shift reactor needs CO₂ compression. The CO₂ feed to the reverse WGS reactors is compressed from nearly atmospheric pressure to the WGS pressure. The increased CO₂ to the reverse WGS reactor also increases the CO₂ removal capacity requirements for the amine scrubber. Additional compression is needed for the air fans associated with the boiler and superheater in the steam cycle. However, these increases in power demand are more than offset by the large increase in power produced because of the increased amount of methane and ethane in the off-gas.

Economic Effects. The replacement of the steam reformer with a reverse shift reactor and CO₂ compressor (and added amine scrubber capacity) saves approximately \$13 million in capital investment for gas conditioning. However, the mixed alcohol synthesis reactor operates at a higher pressure, and has higher throughput, which leads to an \$8 million cost increase. This cost increase is partially offset by reduced clean syngas flow to the synthesis reactor and lower alcohol separation cost because of the lower flow rates. Although the synthesis reactor recycle rate is higher than for the *Base Case*, the capital cost is lower because of the high-pressure amine system in the recycle loop. *Case B4* has less CO₂ to remove from the recycle because of the lower yields. Adding a boiler and superheater to the steam cycle also increases the investment. The total project investment of *Case B3* is less than 1% lower than that for the *Base Case*.

Because more fuel gas is directed to the power generation unit, electric power export is increased by 15% over the *Base Case*; however, the byproduct yield reduces the byproduct credit by about 24%. The net annual production cost for *Case B3* is slightly higher than for the *Base Case*. When this increased production cost is coupled with lower yields, the resulting unit price of ethanol is about 35% higher than that for the *Base Case*.

Model Limitations. It is assumed that a conventional high-temperature shift catalyst can be made to perform a reverse shift reaction by substituting CO₂ for steam and using a high inlet reactor temperature. The cost of the high-pressure amine system in the synthesis recycle loop is based on the amount of CO₂ removed. Pressure effects, either in terms of cost or separation efficiency, are not taken into account. Hence, the capital cost for the amine system is probably low relative to that for the *Base Case*.

Analysis. Replacement of the steam reformer with a less expensive reverse shift reactor and increased power production cannot overcome the significant yield loss associated with methane and ethane as non-reactants in the synthesis step. Therefore, this scenario is not preferred because of its low carbon efficiency. The steam reformer cannot be eliminated or replaced by a shift reactor unless the gasifier can be made to produce low-methane syngas.

3.2.5 Case B4. Methane/Ethane are not Reformed and Clean Syngas Pressure is Unchanged

Case B4 differs from *Case B3* in that the clean syngas pressure (i.e., mixed alcohol synthesis pressure) stays the same as in the *Base Case*. Otherwise, the same process changes are made as in the *Case B3*. The steam reformer is replaced by a reverse shift reactor as a means of adjusting the H₂:CO ratio. This variation on *Case B4* isolates the synthesis pressure effect on overall costs.

Performance Results. *Case B4* has the same raw gas and clean syngas compositions as that of *Case B3*. Therefore, this case also has similar lower final product yields than the *Base Case*. In this case, the clean syngas pressure is the same as the *Base Case* pressure of 2000 psi. Therefore, the clean syngas compressor power consumption for *Case B4* is slightly lower than that of *Case B3*, and is partially offset by small increases in the power requirements for the boiler air and recycle compressor. Electric power production is the same as for *Case B3* because of the high concentration of methane and ethane in the off-gas.

Economic Effects. The capital cost for *Case B4* is lower than those for both the *Base Case* and *Case B3*. The difference between the capital costs for *Case B3* and *Case B4* is the cost for the mixed alcohols synthesis step, which is about 4 mm\$ and is accounted for by the pressure difference. Eliminating the steam reformer and having a reduced synthesis reactant partial pressure is worth about 5 mm\$ over the *Base Case*. However, the changes in capital-related and operating costs do not compensate for the 24% reduction in the mixed alcohol yields for *Case B4* so that the price of ethanol in *Case B4* is only about 2% lower than for *Case B3* and about 32% higher than for the *Base Case*.

Model Limitations. In this case, the partial pressure of CO and H₂ in the clean syngas is lower than that for either the *Base Case* or *Case B3*. The mixed alcohol synthesis model does not consider the impact of the different CO partial pressures on the CO conversion efficiency or selectivity on different mixed alcohol products. The limitations to the high-pressure amine system noted for *Case B3* also apply.

Analysis. The reduction in capital costs resulting from eliminating the steam reformer and increasing electricity sales cannot overcome the poor yields associated with the increased amounts of methane and ethane in the clean syngas. The difference in syngas partial pressure between *Case B3* and *Case B4* are insignificant within the bounds of the model limitations.

3.2.6 Case B5. Tar Production is Assumed to be 1.5 Times that of the Base Case

Case B5 investigated the impact of increasing the tar content in the syngas on the overall system performance and cost. As in *Case A5*, this case is motivated by the uncertainty in the reported tar concentrations in raw gas for the various gasifiers because of differences in the methods used to quantify them. It is not intended to suggest increasing or decreasing the tar content intentionally.

In this case, the tar production estimated by the Eggeman model (Eggeman 2005) is increased by 50% of its predicted value. The syngas concentrations and rates are the same as in the *Base Case*. The char production decreases to balance the increased C and H components in tar. This is a different calculation method than that used in *Case A5* and *Case A6* in which the syngas decreased in response to additional tar formation, while the total char rate was held constant. The indirectly heated gasifier produces much more char than tar, and it is possible to compensate for extra tar production by adjusting the char composition. The directly fired gasifier produces much more tar and less char than the indirectly fired gasifier. It is not possible to balance the difference in tar production by changing the char composition while keeping the rate of char production the same as the *Base Case*.

Steam injection to the gasifier is increased to reach the heat balance for the gasification process. Because of decreased char production, natural gas is sent to the combustor to provide additional heat for feedstock preheating. In addition, a small amount of natural gas also is added to the fuel gas used for

feedstock drying. The recycle ratio of mixed alcohol synthesis is decreased to meet the fuel gas requirement by stream reforming and other processes.

Performance Results. Compared to the *Base Case*, *Case B5* has higher syngas moisture content resulting from increased steam injection. Char production in this case is much lower than the *Base Case* because of the increase in tar production. The scrubber dry raw syngas flow rate is higher than the *Base Case* because more tar is produced and converted into H₂ and CO in the tar reformer. For the same reason, the clean syngas flow rate in *Case B5* is more than that of the *Base Case* by 8%. This results in about a 5% increase in the mixed alcohol production rate over the *Base Case*. This case also has a lower synthesis gas recycle ratio; that is, 94% of the gas is recycled compared with 96% for the *Base Case*. The ethanol yield is 2 mmgal/yr more than that for the *Base Case*.

Because of the higher syngas flow rate, the power consumption for the raw syngas compressor and clean syngas compressor are higher than those for the *Base Case*. This is offset by slightly lower power consumption for the combustor air compressor compared to that for the *Base Case* because the char production is lower, and thus the required air flow for char combustion is also lower. The net power output for *Case B5* is slightly lower than that for the *Base Case*.

Economic Effects. Compared to the *Base Case*, *Case B5* has a slightly lower total installed equipment cost. This is mainly attributed to a \$4 million reduced cost for the synthesis reactor, which is smaller because the recycle ratio for the alcohol synthesis in *Case B5* is lower than that for the *Base Case*. The higher production rate of mixed alcohols results in an approximately 9% reduction in the selling price of ethanol.

Model Limitations. The model results are limited by not knowing how increased tar production affects the char and syngas compositions. The product yield may be artificially inflated by the reduced char production. Another limitation is in the equipment cost estimation for the gasifier and tar cracker. The increased tar production may increase the cost of gasifier, but the current cost model is based on the inlet biomass flow rate and does not consider the impact of different tar generation. The tar cracker cost is calculated based on the volume flow of inlet syngas. The effect of increased tar flow rate on residence time and tar reformer size is not reflected in the model. It also is assumed that increased tar yields do not cause increased fouling problems in any of the downstream equipment.

Analysis. The main reason for the production cost decrease is the increase in carbon efficiency and, thus, the increase in final products.

3.2.7 Case B6. Tar Production is Assumed to be Half that of the Base Case

Case B6 investigates the impacts of lower tar content in the syngas. In this case, the tar production is half that predicted by the Eggeman correlation (Eggeman 2005). The char production is increased to balance the decrease in C and H₂ components in tar. This is similar to the method used in *Case B5*, and differs from the method used in *Case A6* for the reasons already explained. Steam injection to the gasifier is the same as that used for the *Base Case*.

Performance Results. Compared to the *Base Case*, halving the tar content almost doubles char production. Because of the lower tar production and the higher C and H content in the char, less H₂ and CO is produced from tar reforming; thus, the raw syngas flow rate of *Case B6* is lower than that of the

Base Case. For the same reason, the clean syngas flow rate in *Case B6* is lower than that of the *Base Case* by 8%. Because no extra fuel gas is needed for biomass drying, more syngas is recycled for alcohol synthesis than in the *Base Case*. However, the lower clean syngas flow rate leads to lower yields. The carbon efficiency of *Case B6* is lower than that of the *Base Case* because more C and H went to the char and was unavailable for synthesis.

The increased char in the char combustor supplies sufficient exhaust heat to dry the biomass without addition of an extra heat source. Thus, there is no blower power associated with the dryer. The power consumption for the combustor air compressor of *Case B6* is slightly higher than that of *Base Case* because char production is higher and more air is required for combustion. The power consumption levels for the raw syngas compressor and clean syngas compressor in *Case B6* are lower than those of the *Base Case*. The char combustor supplies sufficient heat to the dryer without addition of fuel gas. Because no fuel gas is needed for the dryer, more fuel gas from the synthesis process is available for steam generation than in the *Base Case*. Thus, the steam turbine power generation for *Case B6* is slightly greater than that of *Base Case*. The net power output for *Case B6* also is higher than for the *Base Case*.

Economic Effects. The total capital investment for *Case B6* is slightly less than that for the *Base Case*. The mixed alcohol synthesis reactor installed-equipment cost is higher than that for the *Base Case*, even though the yields are lower. This is because of the increased recycle around the synthesis reactor and the resulting build up of inert materials in the recycle loop.

The lower alcohol byproduct yields resulted in significantly lower byproduct credits that were only partially offset by increased electricity generation. Similarly, the decreased ethanol yield resulted in a further increase in the per-gallon cost of ethanol. The net production cost for *Case B6* is about 12% higher than that of the *Base Case*.

Model Limitations. The main model limitations for *Case B6* are the same as noted for *Case B5*.

Analysis. Although the method used to adjust the tar content was different for the direct gasifier than for the indirect gasifier, both methods showed the same trend, albeit to a different degree. Increased tar formation might lead to increased product yields and, therefore, lower production costs. Decreased tar yields produce the opposite trend.

4.0 Conclusions

The conclusions drawn from analyses and simulation results derived from these investigations are presented on this chapter.

The process economics are improved for both gasifier configurations when the gasifier is operated at elevated pressures (nominally 150 to 300 psig). This improvement is attributed primarily to a significant reduction in the compression capital and operating costs for the raw product gas fed to the LoCAT sulfur-removal system. Specifically, the volume of the product gas is much larger than the volume of the gases that require compression before entering the gasifiers (i.e., compressed CO₂ to the feedstock lock hoppers, pressurized air to the combustor [indirectly heated gasifier], and oxygen to the gasifier [directly heated gasifier]). Increases in the capital cost to pressurize the gasifier systems are much lower than the capital cost savings for the product-gas compressor.

The process economics for both gasifier systems are dominated by the efficiency of converting biomass to CO and H₂. This was shown when examining the possible benefits of eliminating the methane reforming process and altering the amount of tar in the raw product gas. In the case of eliminating the methane reformer, both capital and annual operating costs were reduced for the integrated system using both gasifier configurations. However, this was accompanied by a reduced annual production of mixed alcohols because less syngas was produced due to unconverted methane in the clean syngas. This residual methane ultimately was burned as fuel to produce power and process heat, which are less valuable commodities than the mixed alcohols. A reduction in the mixed alcohol yield results in an increase in the unit cost of mixed alcohols.

In the case of the tar content of the product gas, it was found that the amount of tar in the gas was not itself important because the cracking process would convert the tar to syngas. A more important consideration was whether reducing (or increasing) the tar content in the raw gas was accomplished by changing the amount of char produced in the gasifier. In the current models, char produced in the gasifiers is ultimately combusted to produce process heat for the integrated systems, and possibly electrical power. More importantly, char is not converted into syngas, thereby reducing the amount of mixed alcohol produced by the integrated systems. The net effects of the increased char production that resulted from decreased tar production were minor changes in the capital and annual operating costs, accompanied by a decrease in mixed alcohol production so that the unit price of mixed alcohols would increase.

The manner in which a gasifier is operated and the resulting composition of the raw gas leaving the gasifier also can impact the economics of mixed alcohol production. This was illustrated in *Case A1* in which the gasifier operating conditions were altered to produce a raw product gas with a much higher H₂:CO ratio. To accomplish this, a higher volume of raw gas was produced in the gasifier containing less methane and more H₂, CO, and CO₂, thereby increasing the subsequent compression costs. In addition, additional steam was required, thus increasing the volume of wet product gas passing through the cyclones. However, the H₂:CO ratio required for alcohol synthesis was much lower than that produced by the gasifier, so reverse WGS was required, accompanied by compression and addition of recycle CO₂ to the WGS reactor, which significantly increased the operating costs. In this particular case, the net effect on costs was increased capital costs and lower net electric power generation, without any significant change in the mixed alcohol production rate. However, if the gasifier had been operated in a manner that

did not require reverse WGS to adjust the H₂:CO ratio downward, it may have been possible to reduce net costs. Alternatively, the H₂:CO ratio requirements of the alcohol syntheses reactor are important because they establish the amount of steam and/or CO₂ that needs to be added to the methane reformer to obtain the correct H₂:CO ratio.

In summary, the alternative cases evaluated in this study point to the potential importance of operating the gasifier at elevated pressure, and minimizing gasifier products that ultimately lead to decreased production of H₂ and CO in the clean syngas, specifically char production in the gasifiers, the amount of unconverted tar in the tar cracker, and the amount of unconverted methane leaving the methane reformer. Consideration also should be given to operating the gasifier in a manner that best matches the H₂:CO requirements of the alcohol synthesis reactor without requiring significant forward or reverse WGS in the methane reforming/WGS reactor.

5.0 References

- Aden A, P Spath, and A Atherton. 2005. "The Potential of Thermochemical Ethanol via Mixed Alcohol Production." Milestone Completion Report. FY05-684. October 2005.
- Bechtel. 1998. *Base Design/Economics for Advanced Fischer-Tropsch Technology*. DE-AC22-91PC90027-0,1, Final Report for the U.S. Department of Energy, Washington, D.C.
- Chemical Engineering Magazine*. 2007a. "Economic Indicators: Chemical Engineering Plant Cost Index January 2007 Final." Chemical Week Associates, New York, 114(5):96.
- Chemical Engineering Magazine*. 2007b. "Economic Indicators: Chemical Engineering Plant Cost Index February 2007 Final." Chemical Week Associates, New York, 114(6):84.
- Chemical Engineering Magazine*. 2007c. "Economic Indicators: Chemical Engineering Plant Cost Index March 2007 Final." Chemical Week Associates, New York, 114(7):84.
- Courty P, P Chaumette, C Raimbault, and P Travers P. 1990. "Production of Methanol-Higher Alcohol Mixtures from Natural Gas via Syngas Chemistry." *Revue de l'Institut Francais du Petrole* 45(4):561-78.
- Eggeman T. 2005. "Updated Correlations for GTI Gasifier – WDYLD8." Technical memorandum for Pam Spath, National Renewable Energy Laboratory, Golden, Colorado. June 27, 2005.
- Evans RJ, RA Knight, M Onischak, and SP Babu. 1988. *Development of Biomass Gasification to Produce Substitute Fuels*. Institute of Gas Technology for Pacific Northwest Laboratory, PNL-6518, Richland, Washington.
- Forzatti P, E. Tronconi. and I Pasquon. 1991. "Higher Alcohol Synthesis." *Catalysis Reviews-Science and Engineering* 33(1-2):109-168.
- Hamelinck C and A Faaij. 2002. "Future Prospects for Production of Methanol and Hydrogen from Biomass." *Journal of Power Sources* 111(1):1-22.
- Hamelinck C, A Faaij, H den Uil, and H Boerrigter. 2003. "Production of FT Transportation Fuels from Biomass; Technical Options, Process Analysis and Optimixation and Development Potential." NWS 90-393-3342-4. Utrecht University, Utrecht, The Netherlands.
- Herman RG. 1991. "Chapter 7 - Classical and Non-Classical Routes for Alcohol Synthesis." *New Trends in CO Activation*, L Guzzi, ed., pp 265-349, Elsevier, New York.
- Hofbauer, H and R Rauch. 2001. *Hydrogen-Rich Gas from Biomass Steam Gasification*. Publishable Final Report, Research Funded by the European Commission, Contract No. JOR3CT970196, Institute of Chemical Engineering Fuel and Environmental Technology, Getreidemark 9/159, A-1060 Wien, Austria.
- Hofbauer, H., R. Rauch, B. Klaus, K. Reinhard, and A. Christian. 2002. "Biomass CHP Plant Gussing – A Success Story." Presented at the *Expert Meeting on Pyrolysis and Gasification of Biomass and Waste; October 2002*, Strasbourg, France.

Hutchings GJ, RG Copperthwaite, and NJ Coville. 1988. "Catalysis for Hydrocarbon Formation and Transformations." *South African Journal of Science* 84(1):12-16.

Merichem. 2008. Lo-Cat process. Available at <http://www.gtp-merichem.com/products/lo-cat/diagrams/process.php>.

Naqvi S. 2000. *Opportunities for Gas-to-Liquid Technologies*. SRI Consulting Process Economic Program, Stanford Research Institute. Menlo Park, California.

National Energy Technology Laboratory (NETL). 1998a. *Texaco IGCC Base Case*. PED-IGCC-98-001, Process Engineering Division, revision dated June 2000. Available at <http://www.netl.doe.gov/technologies/coalpower/turbines/refshelf/igcc-h2-sygas/texac3y.pdf>.

National Energy Technology Laboratory (NETL). 1998b. *Shell IGCC Base Case*. PED-IGCC-98-002, Process Engineering Division, revision dated June 2000. Available at http://www.netl.doe.gov/technologies/coalpower/gasification/pubs/pdf/system/shell3x_.pdf.

National Energy Technology Laboratory (NETL). 1998c. *Destec IGCC Base Case*. PED-IGCC-98-003, Process Engineering Division, revision dated June 2000. Available at http://www.netl.doe.gov/technologies/coalpower/gasification/pubs/pdf/system/destx3x_.pdf.

Nexant Inc. 2006. *Equipment Design and Cost Estimation for Small Modular Biomass Systems, Synthesis Gas Cleanup, and Oxygen Separation Equipment. Task 9: Mixed Alcohols From Syngas — State of Technology*. Subcontract Report NREL/SR-510-39947, May 2006, San Francisco, California. Available at <http://www.nrel.gov/docs/fy06osti/39947.pdf>.

Peters MS and KD Timmerhaus. 2003. *Plant Design and Economics for Chemical Engineers*. 5th Edition, McGraw-Hill, Inc., New York.

Wang S (editor). 2003. *PEP Yearbook International*. Volume 1E. 2003. SRI Consulting Process Economic Program, Menlo Park, California. Available at <http://www.sriconsulting.com/PEP/>.

Phillips S, A Aden, J Jechura, and D Dayton. 2007. *Thermochemical Ethanol Via Indirect Gasification and Mixed Alcohol Synthesis of Lignocellulosic Biomass*. NREL/TP-510-41168. National Renewable Energy Laboratory, Golden, Colorado.

Quarderer GJ. 1986. "Mixed Alcohols from Synthesis Gas." Presented at the *78th National AIChE Meeting*, April 1986, New Orleans, Louisiana.

Spath P, A Aden, T Eggerman, M Ringer, B Wallace, and J Jechura. 2005. "Biomass Hydrogen Production Detailed Design and Economics Utilizing the Battelle Columbus Laboratory Indirectly Heated Gasifier." NREL/TP-510-37408, National Renewable Energy Laboratory, Golden, Colorado.

Ullmann's Encyclopedia of Industrial Chemistry. 7th Edition. John Wiley & Sons, Inc. 30 Aug 2007.

Wong SF, MS Patel, and DA Storm. 1986. "Retrofitting Methanol Plants for Higher Alcohols." *78th American Institute of Chemical Engineers, National Meeting*, New Orleans, Louisiana.

Appendix A
Equipment Cost Details

Appendix A

Equipment Cost Details

The costing methods for non-standard and packaged equipment are described below:

1. **Gasifier and Tar Cracker.** The gasifier cost is a function of the dry biomass feed rate, while the tar cracker cost is a function of the syngas standard volumetric flow rate. Pressure effects and residence time effects are not included.
2. **Alcohol Synthesis Reactor.** The mixed alcohol reactor is assumed to be a shell-and-tube reactor, with catalyst in the tubes and steam raised in the shell. The catalyst volume is determined from the gas hourly space velocity ($3000 \text{ vol}_{\text{Gas}}/\text{hr}/\text{vol}_{\text{cat}}$ for the *Base Case*) and the gas volume flow rate at standard conditions as determined from the heat and material balance. A 100-ft tube length is assumed with an allowance above and below the catalyst bed. This is similar to the FT design as provided by Naqvi (2000). The tube diameter is adjusted within a range of 2 to 4 in. to achieve a reasonable length-to-diameter (L/D) ratio. The number of tubes is determined by dividing the total reactor length by the tube length. The shell diameter is found by assuming a 3-in. tube spacing and square pitch. The costs of the shell and tubes are estimated separately using ASPEN Icarus, and then added to estimate the total reactor cost.
3. **Shift Reactor.** The shift reactor is assumed to be an adiabatic, fixed-bed reactor with a gas hourly space velocity of $3000 \text{ Nm}^3/\text{m}^3_{\text{catalyst}}/\text{h}$ and an L/D ratio of 3.
4. **Air Separation Unit.** Data reported in the literature for cryogenic air separation plants are shown below. The regression correlation used in this report is shown on the chart. The data used in the correlation were developed from various reports (NETL 1998; Naqvi 2000; Bechtel 1998). Data from Hammelinck (2000), shown as “a,” “b,” “c” are shown for comparison.

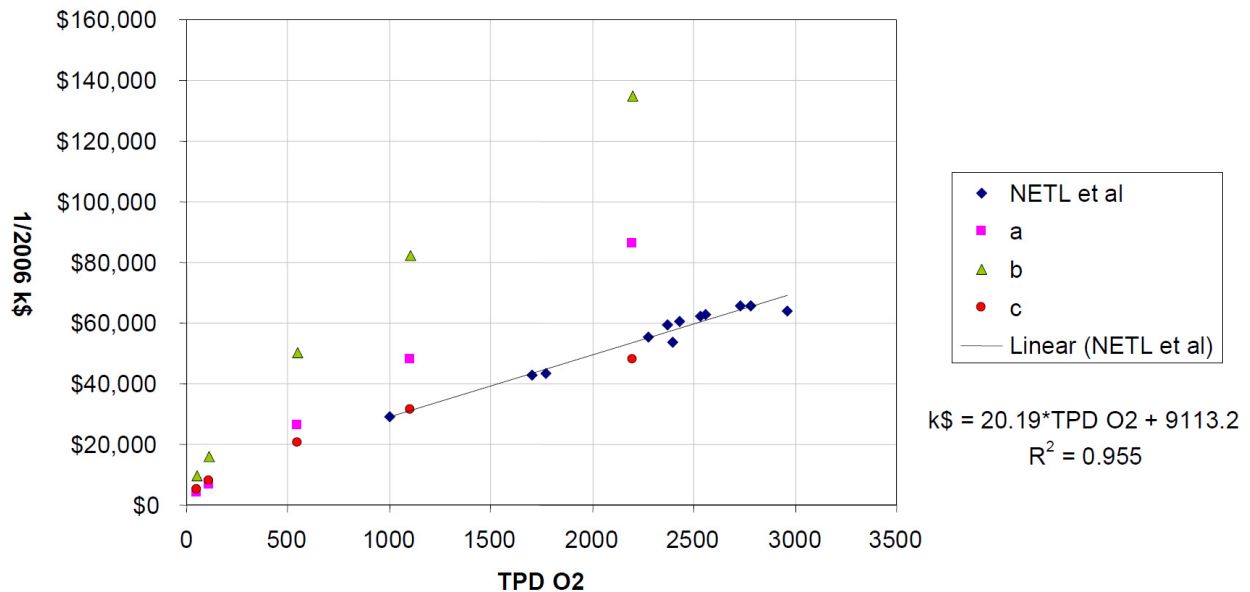

Figure A.1. Installed Costs for Cryogenic Air Separation Units (ASU)

Tables A.1, A.2, and A.3 provide the equipment cost estimation and source details. The cost spreadsheet layout and much of the capital costs were derived from Spath et al. (2005) and Hammelink et al. (2001). The tables contain a list of specific capital costs and the date of the cost. These data are used to provide new capital costs for each case considered in this report as explained in Section 3.5. Table A.1 provides a key to the column headings for Tables A.2 (Indirectly-Heated Gasifier System Base Case) and A.3 Directly-Heated Gasifier System Base Case.

Table A.1. Description of Column Headings for Tables A.2 and A.3

Column Number	Column Heading	Description
1		Processing area number (e.g., A200 is “feedprep”)
2	CC5 Equipment #	Equipment number from CHEMCAD flow sheet (See Appendix C). Note A letter prefix to number indicates type of equipment (E = heat exchanger, P = pump, T = tank or column, V = vessel, R = reactor, C = compressor, H = hot oil system, B = Boiler). NS indicates equipment not shown individually on flow diagrams but part of a group of equipment costed together. Multiple numbers indicates a single piece of equipment shown as multiple pieces in flow sheet (e.g., multiple stages of a compressor. NA means not applicable.
3	# Reqd	Required number of equipment pieces
4	# Spares	Required number of spare equipment pieces
5	Equipment Name	Equipment description
6	Scaling or Stream Factor	Basis for recalculating equipment costs from a base cost. Duty = heat produced or required, Sxxx = refers to a stream number (preceded by the S) that is labeled on the flow diagrams (e.g., S320 means stream 320). See Appendix C for flow stream numbers.
7	Original Stream Flow	Original stream flow or metric (e.g., heat duty) value associated with the base cost
8	New Stream Flow	New stream flow or metric value associated with the case being costed
9	Stream Flow Units	Units for the scaling metric value (MW, lb/hr, etc.)
10	Size Ratio	Ratio of original scaling metric to new scaling metric
11	Original Equipment Cost	Capital cost from the source for the specified equipment
12	Base Year	Year that the capital cost in column 11 was estimated
13	Installed (i) or Bare (b)	Indicates whether the capital cost is an installed cost (i) or bare equipment cost (b)
14	Scaling Exp	Exponent used to scale the capital cost from the original capacity to the capacity in the case being costed
15	Install Factor	Factor that is multiplied by the bare equipment cost to get the installed cost OR factor that is divided into the installed cost to get a bare equipment cost
16	Installed Cost 2007\$	Installed costs escalated from the original cost year (column 12) to 1 st Q 2007 using the CE indices
17	Bare Equipment Cost 2007\$	Bare equipment costs escalated from the original cost year (column 12) to 1 st Q 2007 using the CE indices
18	Equip Cost Source	Source for equipment costs. See following discussion for keys.

The key to the entries in the “equip cost source” column in Table A.1 for the indirectly heated gasifier system equipment is:

1. Spath et al. 2005
2. ICARUS based on CC5 Base Case flow sheet
3. Phillips et al. 2007
4. Wang 2003
5. Hamelinck and Faaij 2002.

The key to the entries in the “equip cost source” column in Table A.2 for the directly heated gasifier system equipment is:

1. Spath et al. 2005
2. Phillips et al. 2007
3. ICARUS based on CC5 Base Case flow sheet
4. PEP 2003 Yearbook (referenced as Wang 2003)
5. Hamelinck and Faaij 2002
6. Various sources, see the references for air separation unit Figure A.1.

Table A.2. Economic Cost Details for Indirectly-Heated Gasifier System Base Case

Equip #	# Reqd	# Spares	Equipment Name	Scaling Stream or factor	Original Stream Flow	New Stream Flow	stream flow units	Size Ratio	Original Equip Cost	Base Year	Installed (i) or bare (b)	Scaling Exp	Install Factor	Installed Cost in 2007\$	Bare Equip cost in 2007\$	Equip Cost Source
A200																
E251	1	0	Flue Gas Cooler / Steam Generator #3	Duty	1,369,986	7,363,000	BTU/h	5.37	\$26,143	2002	b	0.65	2.47	249,970	\$101,202	1
NS	NA	NA	Feed Handling and Drying System	S200	367,437	367,437	lb/h	1.00	\$3,813,728	2002	b	0.65	2.47	24,445,073	\$9,896,791	1
200	2	0	Rotary Biomass Dryer													
203	1	0	Heat exchanger													
NS	4	0	Hopper Feeder													
NS	2	0	Screener Feeder Conveyor													
NS	2	0	Radial Stacker Conveyor													
NS	2	0	Dryer Feed Screw Conveyor													
NS	2	0	Gasifier Feed Screw Conveyor													
NS	2	0	Flue Gas Blower													
NS	4	0	Hydraulic Truck Dump with Scale													
NS	2	0	Hammermill													
NS	3	0	Front End Loaders													1
NS	2	0	Magnetic Head Pulley													
NS	2	0	Screener													
NS	2	0	Dryer Air Cyclone													
NS	2	0	Dryer Air Baghouse Filter													
NS	4	0	Dump Hopper													
NS	1	0	Hammermill Surge Bin													
NS	2	0	Dryer Feed Bin													
NS	2	0	Dried Biomass Hopper													
A300																
E330	1	0	Post-tar Reformer Cooler / Steam Generator #1	Duty	47,912,711	28,650,000	BTU/h	0.60	\$69,089	2002	b	0.65	2.47	158,511	\$64,174	1
E335	1	0	Post-tar Reformer Cooler / BFW Preheater #2	Duty	79,370,881	100,574,000	BTU/h	1.27	\$99,389	2002	b	0.65	2.47	371,523	\$150,414	1
R321	1	0	Tar Reformer	S320	33.8	33.8	Nm3/s	1.00	\$3,100,000	2001	i	0.7	2.47	4,404,179	\$1,783,069	5
V350	2	0	Primary Gasifier Cyclone	S350	33.8	45.8	Nm3/s	1.36	\$2,600,000	2001	i	1.7	2.47	12,382,820	\$5,013,28	5
NS	1	1	Sludge Pump	S200 *0.0027	997	992	lb/h	1.00	\$3,911	2002	b	0.65	2.47	24,988	\$10,117	1
NS	1	0	Sludge Settling Tank	S1702	21,718	86,908	lb/h	4.00	\$11,677	2002	b	0.65	2.47	92,172	\$37,317	1
R305	1	0	Gasification and Cleanup system	S220 (dry feed flow rate)	151,465	183,718	lb/h	1.21	\$12,720,000	1991	i	0.65	2.47	20,487,355	\$8,294,476	5
NS	1	0	Sand/ash Conditioner/Conveyor													
NS	2	0	Combustion Air Blower													
NS	2	0	Sand/ash Cooler													
NS	1	0	Char Combustor													
NS	2	0	Secondary Gasifier Cyclone													
NS	2	0	Primary Combustor Cyclone													
NS	2	0	Secondary Combustor Cyclone													
NS	1	0	Sand/ash Bin													
V340	2	0	Scrubber													
NS	1	0	Quench Water Recirculation Cooler													
NS	1	1	Quench Water Recirculation Pump													
NS	1	0	Quench Water Recirculation Tank													
NS	1	0	Syngas Quench Chamber													
NS	1	0	Syngas Venturi Scrubber													
NS	1	0	Olivine Lock Hopper													
NS	1	0	MgO Lock Hopper													

A.4

Table A.2. (contd)

Equip #	# Reqd	# Spares	Equipment Name	Scaling Stream or factor	Original Stream Flow	New Stream Flow	stream flow units	Size Ratio	Original Equip Cost	Base Year	Installed (i) or bare (b)	Scaling Exp	Install Factor	Installed Cost in 2007\$	Bare Equip cost in 2007\$	Equip Cost Source
A400																
C410, C412, C414, C416, C418 C420	1	0	Syngas Compressor	S345	236,858	193,345	lb/h	0.82	\$10,030,400	2002	b	0.65	2.47	22,899,410	\$9,271,016	1
E411, E412, E415, E17, E19	5	0	Syngas Compressor Intercoolers	Duty	Included in the syngas compressor cost (C-410, etc.)											
NS	4	0	Syngas Compressor Interstage Knock-outs	Duty	Included in the syngas compressor cost (C-410, etc.)											
NS	1	0	Pre-compressor Knock-out	S345	220,009	193,345	lb/h	0.88	\$157,277	2002	b	0.65	2.47	463,455	\$187,633	1
E420	1	0	Water-cooled Aftercooler	Duty	2,938,799	2,734,000	mmbtu/h	0.93	\$20,889	2002	b	0.65	2.47	63,876	\$25,861	1
V429	1	0	Post-compressor Knock-out	S426	179,394	164,720	lb/h	0.92	\$40,244	2002	b	0.65	2.47	122,018	\$49,400	1
E431	1	0	LO-CAT Preheater	Duty	770,434	650,000	BTU/h	0.84	\$4,743	2002	b	0.65	2.47	13,611	\$5,510	1
V430	1	0	LO-CAT Oxidizer Vessel	S434 * 13.5	517	513	lb/h	0.99	\$1,000,000	2002	b	0.65	2.47	3,188,742	\$1,290,989	1
NS	1	0	LO-CAT Absorbent Solution Cooler	Included in LO-CAT oxidizer vessel cost (V-430)												
NS	1	0	LO-CAT Feed Air Blower	Included in LO-CAT oxidizer vessel cost (V-430)												
NS	1	0	LO-CAT Venturi Precontactor	Included in LO-CAT oxidizer vessel cost (V-430)												
NS	1	0	LO-CAT Liquid-filled Absorber	Included in LO-CAT oxidizer vessel cost (V-430)												
NS	1	1	LO-CAT Absorbent Solution Circulating Pump	Included in LO-CAT oxidizer vessel cost (V-430)												
E432	1	0	ZnO Bed Preheater	Duty	47,209,942	39,740,000	BTU/h	0.84	\$71,389	2002	b	0.65	2.47	204,559	\$82,818	1
V435	2	0	ZnO Sulfur Removal Beds	S433	179,237	157,671	lb/h	0.88	\$37,003	2002	b	0.65	2.47	218,217	\$88,347	1
C452	1	0	CO2 Compressor	S454	100,000	13,203	lb/h	0.13	1,237,700	1Q 2005	i	0.65	2.47	364,610	\$147,615	2
C497	1	0	Reformer Flue Gas Blower	S498	534,677	181,568	lb/h	0.34	\$54,250	2002	b	0.65	2.47	86,164	\$34,884	1
E494	1	0	Reformer Feed Preheater	Duty	47,628,665	20,112,400	BTU/h	0.42	\$277,489	2002	b	0.65	2.47	507,802	\$205,588	1
E444	1	0	Reformed Syngas Cooler	Duty	155,010,823	103,972,000	BTU/h	0.67	\$347,989	2002	b	0.65	2.47	860,276	\$348,290	1
E443	1	0	Reformed Syngas Cooler	Duty	13,974,577	13,740,800	BTU/h	0.98	\$92,889	2002	b	0.65	2.47	294,452	\$119,211	1
E442	1	0	Reformed Syngas Cooler	Duty	13,974,577	50,338,700	BTU/h	3.60	\$92,889	2002	b	0.65	2.47	684,766	\$277,233	1
E495	1	0	Reformer Flue Gas Cooler/Steam Superheater #2	Duty	94,212,763	22,305,900	BTU/h	0.24	\$196,589	2002	b	0.65	2.47	246,986	\$99,994	1
NS	1	0	Air-cooled Precooler	Duty	149,281,592	22,974,500	BTU/h	0.15	\$388,064	2002	b	0.65	2.47	368,486	\$149,185	1
E449	1	0	Water-cooled Precooler	Duty	8,414,338	5,636,740	BTU/h	0.67	\$35,689	2002	b	0.65	2.47	88,156	\$35,691	1
C490	1	0	Reformer Combustion Air Blower	S490	304,578	170,009	lb/h	0.56	\$35,020	2002	b	0.65	2.47	76,830	\$31,105	1
R440	1	0	Steam Reformer	DUTY	158,705,747	100,834,000	BTU/h	0.64	\$4,965,833	2002	b	0.65	2.47	11,851,228	\$4,798,068	1
V449	1	0	Knock-out #1	S449	354,424	219,120	lb/h	0.62	\$129,979	2002	b	0.65	2.47	304,746	\$123,379	1
V450	1	0	Amine System (ISBL installed)	S453	100,203	60,065	lb/h CO2	0.60	\$23,000,000	2003	i	0.73	2.47	20,212,675	\$8,183,269	4
C470, C471, C472, C473, C474	1	0	Synth. Feed Compressor w coolers & KO's		161,785	122,595	lb/h	0.76	\$3,896,834	2002	b	0.65	2.47	8,476,493	\$3,431,779	1
NS	1	0	Knock-out #2	S451	242,691	122,595	lb/h	0.51	\$55,291	2002		0.65	2.47	113,681	\$46,025	1
A500 and A600																
R500	1	0	Mixed Alcohol Synthesis Reactor	S512	1,151,936	1,151,936	lb/h	1.00	\$12,674,694	1Q 2005	b	0.65	2.47	34,388,238	\$13,922,363	2
E505	1	0	Feed/Product Exchanger	AREA	20,548	20,548	ft2	1.00	2,290,000	1Q 2007	b	0.65	2.47	5,656,300	\$2,290,000	2
E506	1	0	Product Air Cooler	Duty	104	102	mmbtu/h	0.98	419,400	1Q 2005	b	0.65	2.47	1,120,445	\$453,622	2
E508	1	0	Product Trim Cooler	AREA	8,848	8,848	ft2	1.00	571,300	1Q 2007	b	0.65	2.47	1,411,111	\$571,300	2
V511	1	0	High Pressure V-L Separator	S521	1,151,934	1,151,934	lb/h	1.00	254,800	1Q 2000	b	0.65	2.47	629,347	\$254,797	2
V513	1	0	Low Pressure V-L Separator	S525	78,114	63,509	lb/h	0.81	19,300	1Q 2005	b	0.65	2.47	45,772	\$18,531	2
A-550	1	0	HP Amine System (ISBL installed)	S553	100,203	45,927	lb/h CO2	0.46	\$23,000,000	2003	i	0.73	2.47	16,616,510	\$6,727,332	4
C-551	1	0	Recycle Compressor	S555	1,020,705	1,020,730	lb/h	1.00	1,002,900	1Q 2005	i	0.65	2.47	1,101,641	\$446,008	2
E-560	1	0	Recycle Methanol Vaporizer	AREA	175	122	ft2	0.70	19,700	1Q 2005	b	0.65	2.47	42,276	\$17,116	2
P-612	1	0	Recycle Methanol Pump	S612	12,414	8,608	lb/h	0.69	0	1Q 2005	b	0.65	2.47	0	\$0	2
MS620	1	0	Molecular Sieve Alcohol Dryer	S621	45,175	59,844	lb/h	1.32	904,694	1998	b	0.7	2.47	3,585,487	\$1,451,614	3
T-601	1	0	Light Ends Column	S528	73,801	60,699	lb/h	0.82	271,800	1Q 2005	b	0.65	2.47	649,456	\$262,937	2
T-610	1	0	Methanol Column	S623	64,269	52,045	lb/h	0.81	1,604,500	1Q 2005	b	0.65	2.47	3,795,400	\$1,536,599	2

A.S

Table A.2. (contd)

Equip #	# Reqd	# Spares	Equipment Name	Scaling Stream or factor	Original Stream Flow	New Stream Flow	stream flow units	Size Ratio	Original Equip Cost	Base Year	Installed (i) or bare (b)	Scaling Exp	Install Factor	Installed Cost in 2007\$	Bare Equip cost in 2007\$	Equip Cost Source
T-630	1	0	Ethanol Column	S631	37,727	31,717	lb/h	0.84	410,700	1Q 2005	b	0.65	2.47	995,435	\$403,010	2
T-640	1	0	Propanol Column	S641	7,748	6,518	lb/h	0.84	183,400	1Q 2005	b	0.65	2.47	444,706	\$180,043	2
T-650	1	0	Butanol Column	S651	3,329	2,825	lb/h	0.85	261,000	1Q 2005	b	0.65	2.47	636,460	\$257,676	2
E601	1	0	Light Ends Column Condenser	DUTY	8.46	8.46	mmbtu/h	1.00	\$24,800	1Q 2005	b	0.65	2.47	67,286	\$27,241	2
E602	1	0	Light Ends Column Reboiler	DUTY	12.96	12.96	mmbtu/h	1.00	104,900	1Q 2005	b	0.65	2.47	284,609	\$115,226	2
E611	1	0	Methanol Column Condenser	DUTY	96.32	96.17	mmbtu/h	1.00	54,100	1Q 2005	b	0.65	2.47	146,632	\$59,365	2
E612	1	0	Methanol Column Reboiler	DUTY	96.42	96.27	mmbtu/h	1.00	22,300	1Q 2005	b	0.65	2.47	60,442	\$24,470	2
E631	1	0	Ethanol Column Condenser	DUTY	33.04	33.04	mmbtu/h	1.00	5,800	1Q 2005	b	0.65	2.47	15,736	\$6,371	2
E632	1	0	Ethanol Column Reboiler	DUTY	32.82	32.82	mmbtu/h	1.00	52,500	1Q 2005	b	0.65	2.47	142,440	\$57,668	2
E641	1	0	Propanol Column Condenser	DUTY	5.76	5.76	mmbtu/h	1.00	183,500	1Q 2005	b	0.65	2.47	497,861	\$201,563	2
E642	1	0	Propanol Column Reboiler	DUTY	5.76	5.76	mmbtu/h	1.00	123,300	1Q 2005	b	0.65	2.47	334,530	\$135,437	2
E651	1	0	Butanol Column Condenser	DUTY	2.11	2.11	mmbtu/h	1.00	39,500	1Q 2005	b	0.65	2.47	107,169	\$43,388	2
E652	1	0	Butanol Column Reboiler	DUTY	2.12	2.12	mmbtu/h	1.00	29,300	1Q 2005	b	0.65	2.47	79,495	\$32,184	2
H-680	1	0	Hot Oil System for T-640 & T-650	DUTY	8.00	7.88	mmbtu/h	0.99	214,000	1Q 2005	b	1.65	2.47	566,312	\$229,276	2
Misc equipment contingency (reflux drums, pumps, etc)				Estimated from distillation costs	5%				136,570	1Q 2005	b	0.65	2.47	370,534	\$150,014	2
A700																
E770	1	0	Blowdown Cooler / Deaerator Water Preheater	S770	2,877,029	89,545	lb/h	0.03	\$3,043	2002	b	0.6	2.47	1,153	\$467	1
NS	1	0	Blowdown Water-cooled Cooler	S711	626,343	3,815	lb/h	0.01	\$16,143	2002	b	0.44	2.47	5,199	\$2,105	1
NS	1	0	Hot Process Water Softener System	S777-S770	349,266	218,422	lb/h	0.63	\$1,031,023	1999	b	0.82	2.47	2,157,172	\$873,349	1
EX730.7 40, 750	1	0	Extraction Steam Turbine/Generator	S725	342,283	394,082	lb/h	1.15	\$4,045,870	2002	b	0.71	2.47	13,588,341	\$5,501,353	1
NS	1	0	Steam Turbine Condenser	Included in the extraction steam turbine/generator cost												
	1	0	Startup Boiler	Calculated from gasifier size	36,560	36,560	lb/h	1.00	\$198,351	2002	b	0.6	2.47	602,749	\$244,028	1
B715	1	0	Fuel Gas Steam Boiler (mult for higher pressure)	Scenario dependent	169,341	165,198	lb/h	0.98	\$1,748,700	1Q 2005	i	0.6	2.47	2,119,659	\$858,161	1
P782	1	1	BFW HP pump	S782	255,292	397,894	lb/h	1.56	\$7,015	2002	b	0.33	2.47	49,358	\$19,983	1
P761	1	1	Condensate Pump	S761	93,974	166,852	lb/h	1.78	\$5,437	2002	b	0.33	2.47	39,936	\$16,169	1
NS	1	1	Deaerator Feed Pump	S777	349,266	307,967	lb/h	0.88	\$8,679	2002	b	0.33	2.47	50,602	\$20,487	1
P780	1	1	Boiler Feed Water Pump	S779	349,268	476,818	lb/h	1.37	\$95,660	2002	b	0.33	2.47	644,283	\$260,843	1
NS	1	0	Condensate Collection Tank	S777	349,266	307,967	lb/h	0.88	\$24,493	2002	b	0.6	2.47	69,016	\$27,942	1
NS	1	0	Condensate Surge Drum	S777	349,268	307,967	lb/h	0.88	\$28,572	2002	b	0.6	2.47	80,510	\$32,595	1
V705	1	0	Deaerator	S777	349,266	307,967	lb/h	0.88	\$130,721	2002	b	0.72	2.47	362,826	\$146,893	1
V700	1	0	Steam Drum	S704	349,268	232,690	lb/h	0.67	\$9,200	1997	b	0.72	2.47	21,332	\$8,637	1
V703	1	0	Blowdown Flash Drum	S711+S1974	6,985	3,815	lb/h	0.55	\$14,977	2002	b	0.6	2.47	31,661	\$12,818	1
900 (miscellaneous equipment)																
NS	2	1	Plant Air Compressor	S200	367,437	367,437	lb/h	1.00	\$32,376	2002	b	0.34	2.47	295,155	\$119,496	1
NS	1	0	Cooling Tower System	calculated	139,850,763	40,921,343	lb/h	0.29	\$267,316	2002	b	0.78	2.47	311,479	\$126,105	1
NS	1	0	Hydraulic Truck Dump with Scale	S200	367,437	367,437	lb/h	1.00	\$80,000	1998	b	0.6	2.47	246,595	\$99,836	1
NS	1	0	Flue Gas Stack	S380+S498+S756	1,174,206	881,559	lb/h	0.75	\$51,581	2002	b	1	2.47	117,679	\$47,643	1
NS	1	1	Cooling Water Pump	calculated	6,088,320	6,138,201	lb/h	1.01	\$158,540	2002	b	0.33	2.47	966,140	\$391,150	1
NS	1	1	Firewater Pump	S200	367,437	367,437	lb/h	1.00	\$18,400	1997	b	0.79	2.47	114,313	\$46,280	1
NS	1	1	Diesel Pump	S200	367,437	367,437	lb/h	1.00	\$6,100	1997	b	0.79	2.47	37,897	\$15,343	1
NS	1	1	Ammonia Pump	S200	367,437	367,437	lb/h	1.00	\$6,100	1997	b	0.79	2.47	37,897	\$15,343	1
NS	1	0	Hydrazine Pump	S200	367,437	367,437	lb/h	1.00	\$5,500	1997	b	0.79	2.47	17,085	\$6,917	1
NS	1	1	Instrument Air Dryer	S200	367,437	367,437	lb/h	1.00	\$8,349	2002	b	0.6	2.47	50,742	\$20,543	1
NS	1	0	Plant Air Receiver	S200	367,437	367,437	lb/h	1.00	\$7,003	2002	b	0.72	2.47	21,281	\$8,616	1
NS	1	0	Firewater Storage Tank	S200	367,437	367,437	lb/h	1.00	\$166,100	1997	b	0.51	2.47	515,961	\$208,891	1
NS	1	0	Diesel Storage Tank	S200	367,437	367,437	lb/h	1.00	\$14,400	1997	b	0.51	2.47	44,731	\$18,110	1
NS	1	0	Ammonia Storage Tank	S200	367,437	367,437	lb/h	1.00	\$287,300	1997	b	0.72	2.47	892,447	\$361,315	1
NS	1	0	Hydrazine Storage Tank	S200	367,437	367,437	lb/h	1.00	\$12,400	1997	b	0.93	2.47	38,518	\$15,595	1

Table A.3. Economic Cost Details for Directly-Heated Gasifier System Base Case

CC5 Equip #	# Reqd	# Spare	Equipment Name	Scaling Stream or Factor	Original Stream Flow	New Stream Flow	Stream Flow Units	Size Ratio	Original Equip Cost (per unit)	Base Year	Installed (i) or Bare (b)	Scaling Exp	Install Factor	Installed Cost in 2007\$	Bare Equip cost in 2007\$	Equip Cost Source
A100																
110	1	0	Air Separation Package Unit	S119		504	mtpd		2 cost scales: 50-1000 & 1000-4000 tpd O2	2006	i		2.47	22,472,171	\$9,098,045	6
A200																
	1	0	CO2 Lock Hopper Compressor	S230	6,023	6,023	lb/h	1.00	\$1,000,000	2006	b	0.65	2.47	3,204,881	\$1,297,523	1
251	1	0	Flue Gas Cooler / Steam Generator #3		1,369,986	0	BTU/h	0.00	\$26,143	2002	b	0.65	2.47	0	\$0	1
NS	NA	NA	Feed Handling and Drying System		367,437	367,437	lb/h	1.00	\$3,813,728	2002	b	0.65	2.47	24,445,073	\$9,896,791	1
200	2	0	Rotary Biomass Dryer													1
NS	NA	NA	Feed Handling and Drying System Auxiliary Equipment (assumed to be similar to the auxiliary equipment for the indirectly heated Gasifier system – see Table B.2)													1
A300																
E330	1	0	Post-tar Reformer Cooler / Steam Generator #1	Duty	47,912,711	120,700,000	BTU/h	2.52	\$69,089	2002	b	0.65	2.47	403,680	\$163,433	1
E335	1	0	Post-tar Reformer Cooler / BFW Preheater #2	Duty	79,370,881	26,670,000	BTU/h	0.34	\$99,389	2002	b	0.65	2.47	156,778	\$63,473	1
R321	1	0	Tar Reformer	S330	34.2	36.4	Nm3/s	1.06	\$3,100,000	2001	i	0.7	2.47	4,600,634	\$1,862,605	5
V310	4	0	Primary Gasifier Cyclone	S304	34.2	33.4	Nm3/s	0.98	\$2,600,000	2001	i	0.7	2.47	14,532,519	\$5,883,611	5
NS	1	1	Sludge Pump	S200 *0.0027	997	992	lb/h	1.00	\$3,911	2002	b	0.65	2.47	24,988	\$10,117	1
NS	1	0	Sludge Settling Tank	S1702	21,718	86,395	lb/h	3.98	\$11,677	2002	b	0.65	2.47	91,818	\$37,173	1
NA	NA	NA	Directly-heated Biomass Gasifier and Clean Up System	S220 (dry feed flow rate)	151,465	91,859	lb/h	0.61	\$29,740,000	1991	i	0.65	2.47	91,578,072	\$37,076,143	5
R305	2	1	Directly heated Gasifier													5
NS	1	0	Olivine Lock Hopper													
NS	1	0	MgO Lock Hopper													
NS	NA	NA	Gasification & Clean up System Auxiliary Equipment (assumed to be similar to the auxiliary equipment for the indirectly heated Gasifier system – see Table B.2)													
A400																
C418	1	0	Syngas Compressor	Duty	2.84	1.88	MW	0.66	\$979,500	1st Q 2005	i	0.65	2.47	822,859	\$333,141	1
E417	1	0	Syngas Compressor Intercoolers													1
NS	1	0	Pre-compressor Knock-out	S380	220,009	249,032	lb/h	1.13	\$157,277	2002		0.65	2.47	546,332	\$221,187	
E419	1	0	Water-cooled Aftercooler	Duty	2,938,799	3,980,000	BTU/h	1.35	\$20,889	2002	b	0.65	2.47	81,535	\$33,010	
V429	1	0	Post-compressor Knock-out	S427	179,394	249,032	lb/h	1.39	\$40,244	2002	b	0.65	2.47	159,626	\$64,626	
E431	1	0	LO-CAT Preheater		770,434	1,395,000	BTU/h	1.81	\$4,743	2002	b	0.65	2.47	22,359	\$9,052	
V430	1	0	LO-CAT Oxidizer Vessel	S434*13.5	517	513	lb/h	0.99	\$1,000,000	2002	b	0.65	2.47	3,188,742	\$1,290,989	
NS	1	0	LO-CAT Absorbent Solution Cooler													
NS	1	0	LO-CAT Feed Air Blower													
NS	1	0	LO-CAT Venturi Precontactor													
NS	1	0	LO-CAT Liquid-filled Absorber													
NS	1	1	LO-CAT Absorbent Solution Circulating Pump													
E432	1	0	ZnO Bed Preheater	Duty	47,209,942	57,409,000	BTU/h	1.22	\$71,389	2002	b	0.65	2.47	259,812	\$105,187	1
V435	2	0	ZnO Sulfur Removal Beds	S433	179,237	248,190	lb/h	1.38	\$37,003	2002		0.65	2.47	293,063	\$118,649	1
C497	1	0	Reformer Flue Gas Blower	S498	534,677	310,052	lb/h	0.58	\$54,250	2002	b	0.65	2.47	122,007	\$49,396	1
E495	1	0	Reformer Flue Gas Cooler/Superhr	Duty	129,174,690	44,147,000	BTU/h	0.34	\$144,006	2003	b	0.63	2.47	234,660	\$95,004	1

A.7

Table A.3. (contd)

CC5 Equip #	# Req'd	# Spare	Equipment Name	Sealing Stream or Factor	Original Stream Flow	New Stream Flow	Stream Flow Units	Size Ratio	Original Equip Cost (per unit)	Base Year	Installed (i) or Bare (b)	Sealing Exp	Install Factor	Installed Cost in 2007\$	Bare Equip cost in 2007\$	Equip Cost Source
E494	1	0	Reformer Feed Preheater	Duty	47,628,665	37,339,000	BTU/h	0.78	\$277,489	2002	b	0.65	2.47	759,187	\$307,363	1
E444	1	0	Reformed Syngas Cooler	Duty	155,010,823	248,547,000	BTU/h	1.60	\$347,989	2002	b	0.65	2.47	1,515,855	\$613,707	1
E443	1	0	Reformed Syngas Cooler	Duty	13,974,577	23,774,000	BTU/h	1.70	\$92,889	2002	b	0.65	2.47	420,506	\$170,245	1
E442	1	0	Reformed Syngas Cooler	Duty	94,212,763	45,839,000	BTU/h	0.49	\$196,589	2002	b	0.65	2.47	394,460	\$159,700	1
E446	1	0	Air-cooled Precooler	Duty	149,281,592	61,827,000	BTU/h	0.41	\$388,064	2002	b	0.65	2.47	701,257	\$283,910	1
E445	1	0	Water-cooled Precooler	Duty	8,414,338	7,743,000	BTU/h	0.92	\$35,689	2002	b	0.65	2.47	108,361	\$43,871	1
C490	1	0	Reformer Combustion Air Blower	S490	304,578	286,107	lb/h	0.94	\$35,020	2002	b	0.65	2.47	107,762	\$43,629	1
R440	1	0	Steam Reformer	Duty	158,705,747	172,000,000	BTU/h	1.08	\$4,965,833	2002	b	0.65	2.47	16,769,199	\$6,789,149	1
V450	1	0	Amine System (ISBL installed)	S453	100,203	100,452	lb/h CO2	1.00	\$15,400,000	2003	i	0.65	2.47	19,695,479	\$7,973,878	4
C470, C471, C472, C473, C474	1	0	Synthesis Feed Compressor with interstage coolers included		8.40	8.26	MW	0.98	\$3,774,000	2002	i	0.65	2.47	3,937,017	\$1,593,934	1
V449	1	0	Knock-out #1	S449	354,424	308,155	lb/h	0.87	\$129,979	2002	b	0.65	2.47	380,360	\$153,992	1
NS	1	0	Knock-out #2	S451	242,691	147,033	lb/h	0.61	\$55,291	2002		0.65	2.47	127,938	\$51,797	1
A500 & 600																
R500	1	0	Mixed Alcohol Synthesis Reactor	S12	729,095	729,095	lb/h	1.00	7,715,966	1st Q 2005	b	0.65	2.47	20,934,508	\$8,475,509	2
E505	1	0	Feed/Product Exchanger	AREA	5,829	6,783	ft2	1.16	158,400	1st Q 2005	b	0.65	2.47	474,259	\$192,008	2
E506	1	0	Product Air Cooler	mmbtu/h	104	114	MMBTU/H	1.10	419,400	1st Q 2005	b	0.65	2.47	1,207,862	\$489,013	2
E508	1	0	Product Trim Cooler	AREA	2,706	3,105	ft2	1.15	216,200	1st Q 2005	b	0.65	2.47	641,439	\$259,692	2
V511	1	0	High Pressure V-L Separator	S21	644,469	729,107	lb/h	1.13	99,100	1st Q 2005	b	0.65	2.47	291,326	\$117,946	2
V513	1	0	Low Pressure V-L Separator	S25	78,114	78,542	lb/h	1.01	19,300	1st Q 2005	b	0.65	2.47	52,550	\$21,275	2
A-550	1	0	High Pressure Amine Unit	S53	53,123	54,754	lb/h CO2	1.03	\$10,900,000	2003	i	0.65	2.47	14,194,115	\$5,746,605	4
C-551	1	0	Recycle Compressor	S555	1,020,705	569,788	lb/h	0.56	1,002,900	1Q 2005	i	0.65	2.47	754,157	\$305,327	2
E-560	1	0	Recycle Methanol Vaporizer	area	175	174	ft2	0.99	19,700	1st Q 2005	b	0.65	2.47	53,250	\$21,559	2
P-612	1	0	Recycle Methanol Pump	S612	12,414	12,274	lb/h	0.99	0	1st Q 2005	b	0.65	2.47	0	\$0	2
MS620	1	0	Molecular Sieve Alcohol Drier	S621	73,214	72,526	lb/h	0.99	2,700,000	1998	b	0.65	2.47	8,734,926	\$3,536,407	3
T-601	1	0	Light Ends Column	S528	73,801	74,279	lb/h	1.01	271,800	1Q 2005	b	0.65	2.47	740,533	\$299,811	2
T-610	1	0	Methanol Column	S624	64,269	64,813	lb/h	1.01	1,604,500	1Q 2005	b	0.65	2.47	4,377,151	\$1,772,126	2
T-630	1	0	Ethanol Column	S631	37,727	51,177	lb/h	1.36	410,700	1Q 2005	b	0.65	2.47	1,358,538	\$550,015	2
T-640	1	0	Propanol Column	S641	7,748	12,927	lb/h	1.67	183,400	1Q 2005	b	0.65	2.47	694,020	\$280,980	2
T-650	1	0	Butanol Column	S651	3,329	5,074	lb/h	1.52	261,000	1Q 2005	b	0.65	2.47	931,294	\$377,042	2
E601	1	0	Light Ends Column Condenser	DUTY	8.46	11.78	mmbtu/h	1.39	\$24,800	1Q 2005	b	0.65	2.47	83,441	\$33,782	2
E602	1	0	Light Ends Column Reboiler	DUTY	12.96	17.31	mmbtu/h	1.34	104,900	1Q 2005	b	0.65	2.47	343,517	\$139,076	2
E611	1	0	Methanol Column Condenser	DUTY	96.32	135.18	mmbtu/h	1.40	54,100	1Q 2005	b	0.65	2.47	182,956	\$74,071	2
E612	1	0	Methanol Column Reboiler	DUTY	96.42	135.36	mmbtu/h	1.40	22,300	1Q 2005	b	0.65	2.47	75,429	\$30,538	2
E631	1	0	Ethanol Column Condenser	DUTY	33.04	39.80	mmbtu/h	1.20	5,800	1Q 2005	b	0.65	2.47	17,760	\$7,190	2
E632	1	0	Ethanol Column Reboiler	DUTY	32.82	39.50	mmbtu/h	1.20	52,500	1Q 2005	b	0.65	2.47	160,668	\$65,048	2
E641	1	0	Propanol Column Condenser	DUTY	5.76	6.87	mmbtu/h	1.19	183,500	1Q 2005	b	0.65	2.47	558,285	\$226,026	2
E642	1	0	Propanol Column Reboiler	DUTY	5.76	6.84	mmbtu/h	1.19	123,300	1Q 2005	b	0.65	2.47	374,065	\$151,443	2
E651	1	0	Butanol Column Condenser	DUTY	2.11	2.52	mmbtu/h	1.19	39,500	1Q 2005	b	0.65	2.47	120,281	\$48,697	2
A700																
E740	1	0	Extraction Steam Turbine/Generator	S725	342,283	285,364	lb/h	0.83	\$4,045,870	2002	b	0.71	2.47	12,966,534	\$5,249,609	1
NS	1	0	Steam Turbine Condenser						Included in the extraction steam turbine/generator cost							
E770	1	0	Blowdown Cooler / Deaerator Water Preheater		2,877,029	1,203,320	mmbtu/h	0.42	\$3,043	2002	b	0.6	2.47	9,752	\$3,948	1
NS	1	0	Hot Process Water Softener System	S778	349,266	425,406	lb/h	1.22	\$1,031,023	1999	b	0.82	2.47	3,346,604	\$1,354,900	1
NS	1	0	Startup Boiler	calculated	36,560	36,560	lb/h	1.00	\$198,351	2002	b	0.6	2.47	635,691	\$257,365	1
	0	0	Fuel Gas Steam Boiler (mult for higher pressure)	Scenario dependent			lb/h	0.00	\$1,748,700	1Q 2005	i	0.6	2.47	0	\$0	2
NS	1	1	Collection Pump	S776	255,292	244,523	lb/h	1.44	\$7,015	2002	b	0.33	2.47	44,964	\$18,204	1

Table A.3. (contd)

CC5 Equip #	# Reqd	# Spare	Equipment Name	Scaling Stream or Factor	Original Stream Flow	New Stream Flow	Stream Flow Units	Size Ratio	Original Equip Cost (per unit)	Base Year	Installed (i) or Bare (b)	Scaling Exp	Install Factor	Installed Cost in 2007\$	Bare Equip cost in 2007\$	Equip Cost Source
NS	1	1	Condensate Pump	S761	93,974	64,246	lb/h	0.25	\$5,437	2002	b	0.33	2.47	34,850	\$14,109	1
NS	1	1	Deaerator Feed Pump	S778	349,266	425,406	lb/h	4.53	\$8,679	2002	b	0.33	2.47	55,630	\$22,522	1
P780	1	1	Boiler Feed Water Pump	S778	349,268	425,406	lb/h	1.22	\$95,660	2002	b	0.33	2.47	613,158	\$248,242	1
NS	1	0	Condensate Collection Tank	S778	349,266	425,406	lb/h	1.22	\$24,493	2002	b	0.6	2.47	78,497	\$31,780	1
NS	1	0	Condensate Surge Drum	S778	349,268	425,406	lb/h	1.22	\$28,572	2002	b	0.6	2.47	91,570	\$37,073	1
V706	1	0	Deaerator	S778	349,266	425,406	lb/h	1.22	\$130,721	2002	b	0.72	2.47	418,945	\$169,613	1
V700	1	0	Steam Drum	S778	349,268	425,406	lb/h	1.22	\$9,200	1997	b	0.72	2.47	30,179	\$12,218	1
V703	1	0	Blowdown Flash Drum	S710	6,985	2,882	lb/h	0.01	\$14,977	2002	b	0.6	2.47	48,001	\$19,434	1
A900																
NS	2	1	Plant Air Compressor	S200	367,437	367,437	lb/h	1.00	\$32,376	2002	b	0.34	2.47	311,286	\$126,027	1
NS	1	0	Cooling Tower System	calculated	139,850,763	81,483,762	lb/h	0.58	\$267,316	2002	b	0.78	2.47	856,716	\$346,849	1
NS	1	0	Hydraulic Truck Dump with Scale	S200	367,437	367,437	lb/h	1.00	\$80,000	1998	b	0.6	2.47	260,406	\$105,427	1
NS	1	0	Flue Gas Stack	S380+S498	1,174,206	693,431	lb/h	0.59	\$51,581	2002	b	1	2.47	165,311	\$66,928	1
NS	1	1	Cooling Water Pump	calculated	6,088,320	3,547,347	lb/h	0.58	\$158,540	2002	b	0.33	2.47	1,017,598	\$411,983	1
NS	1	1	Firewater Pump	S200	367,437	367,437	lb/h	1.00	\$18,400	1997	b	0.79	2.47	120,716	\$48,873	1
NS	1	1	Diesel Pump	S200	367,437	367,437	lb/h	1.00	\$6,100	1997	b	0.79	2.47	40,020	\$16,202	1
NS	1	1	Ammonia Pump	S200	367,437	367,437	lb/h	1.00	\$6,100	1997	b	0.79	2.47	32,803	\$13,281	1
NS	1	0	Hydrazine Pump	S200	367,437	367,437	lb/h	1.00	\$5,500	1997	b	0.79	2.47	18,042	\$7,304	1
NS	1	1	Instrument Air Dryer	S200	367,437	367,437	lb/h	1.00	\$8,349	2002	b	0.6	2.47	53,515	\$21,666	1
NS	1	0	Plant Air Receiver	S200	367,437	367,437	lb/h	1.00	\$7,003	2002	b	0.72	2.47	22,444	\$9,087	1
NS	1	0	Firewater Storage Tank	S200	367,437	367,437	lb/h	1.00	\$166,100	1997	b	0.51	2.47	544,864	\$220,593	1
NS	1	0	Diesel Storage Tank	S200	367,437	367,437	lb/h	1.00	\$14,400	1997	b	0.51	2.47	47,237	\$19,124	1
NS	1	0	Ammonia Storage Tank	S200	367,437	367,437	lb/h	1.00	\$287,300	1997	b	0.72	2.47	942,441	\$381,555	1
NS	1	0	Hydrazine Storage Tank	S200	367,437	367,437	lb/h	1.00	\$12,400	1997	b	0.93	2.47	892,447	\$361,315	1

Appendix B

Base Case Flow Sheets and Model Results

Appendix B

Base Case Flow Sheets and Model Results

The *Base Case* flow diagrams and symbols generated in CHEMCAD are depicted in the following diagrams. An individual diagram is provided for each section. The equipment numbers are the same as those in Tables A.2 and A.3.

B.1 Indirectly Heated Gasifier Model

Figure B.1 shows the process flow diagram for the *Base Case* indirectly heated gasifier-based system. The flow sheet for each main area in the system is shown in Figures B.2 to B.7. The material and energy information for each unit operation and stream are summarized in Table B.1

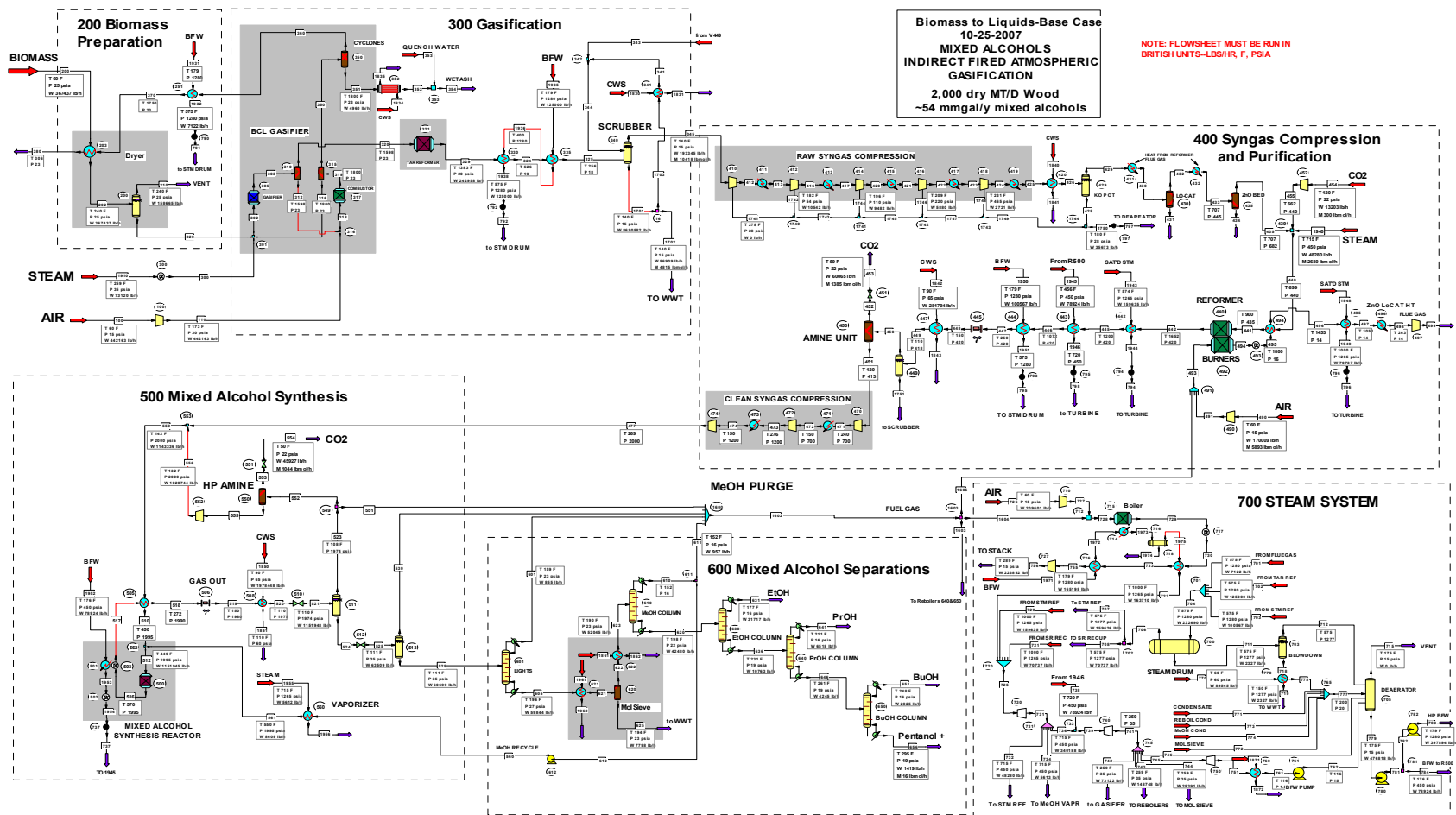

B.2

Figure B.1. Flow Sheet for Overall Mixed Alcohols Production System – Indirectly Heated Gasifier Base Case

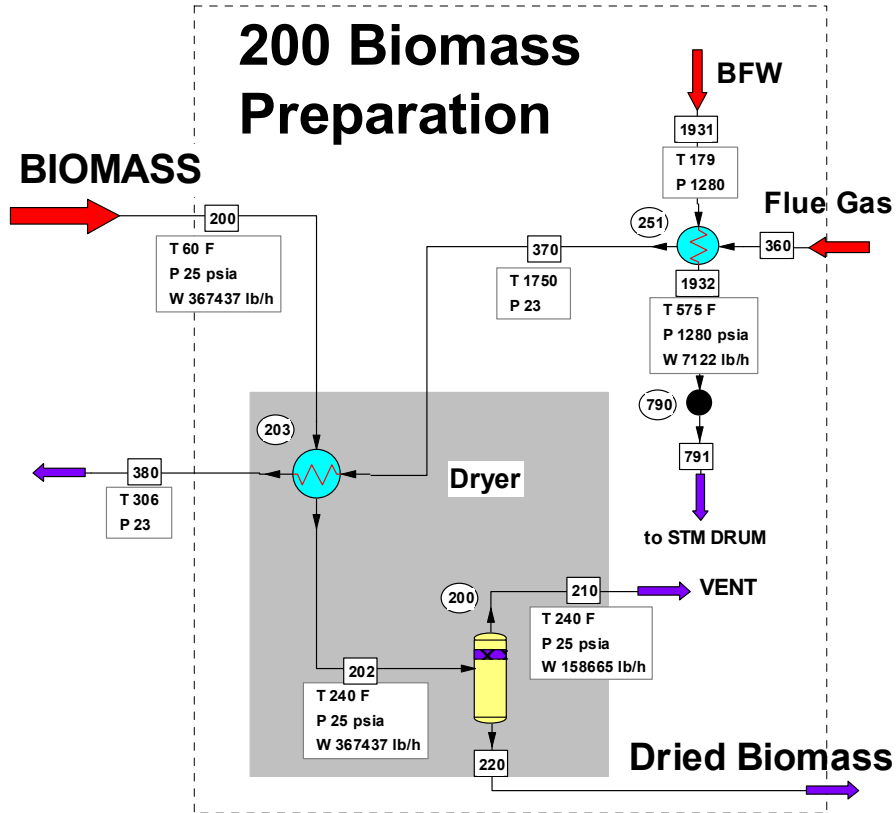

Figure B.2. Flow Sheet for Area 200 Biomass Preparation – Indirectly Heated Gasifier Base Case

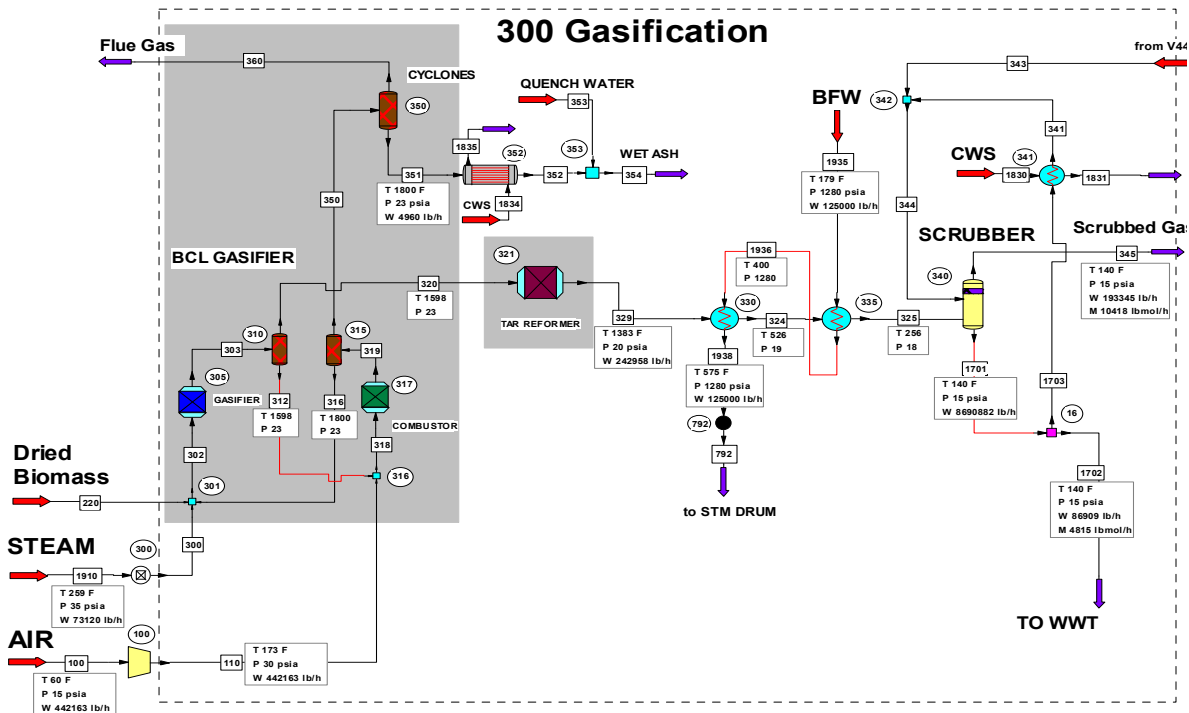

Figure B.3. Flow Sheet for Area 300 Gasification – Indirectly Heated Gasifier Base Case

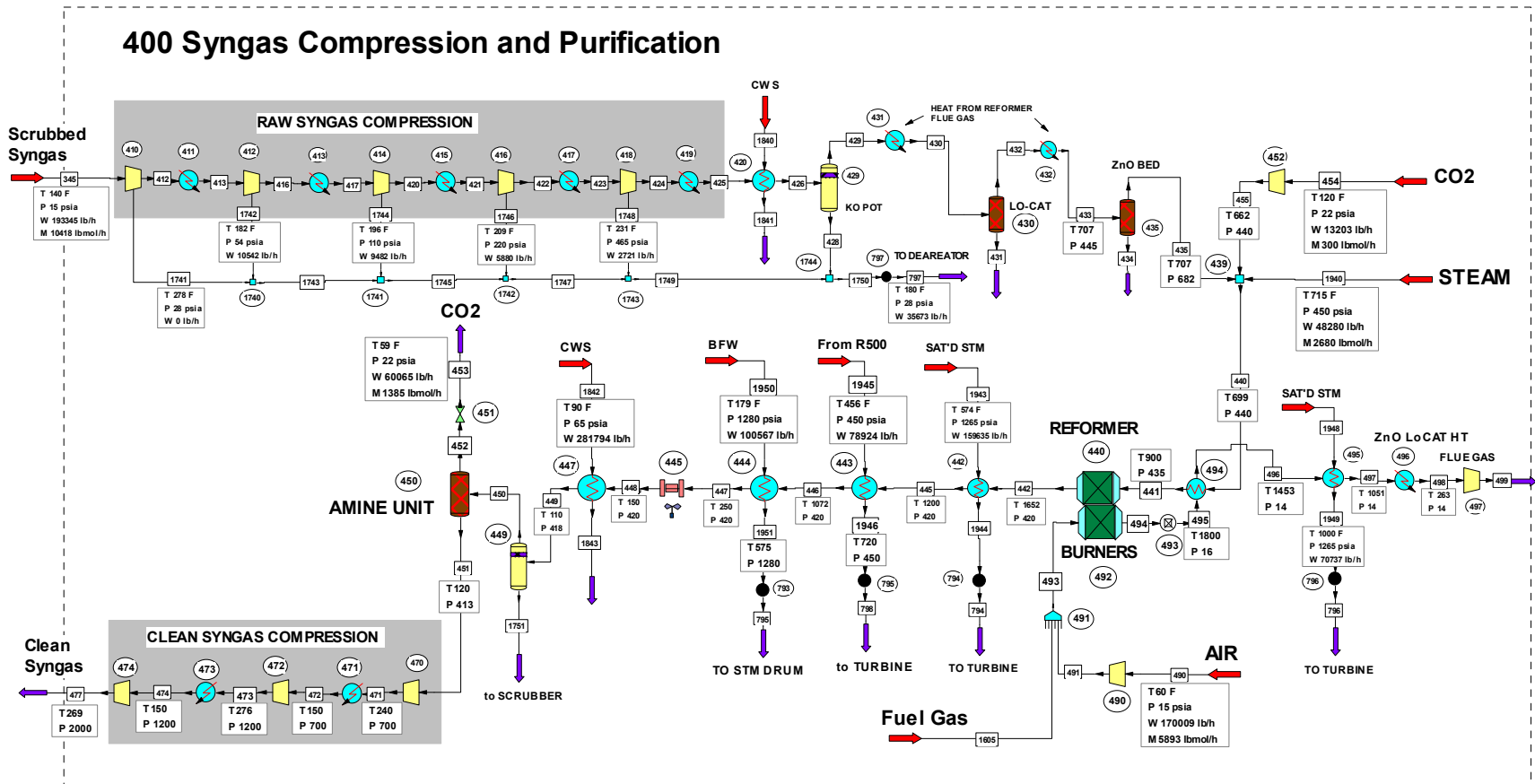

Figure B.4. Flow Sheet for Area 400 Syngas Compression and Purification – Indirectly Heated Gasifier Base Case

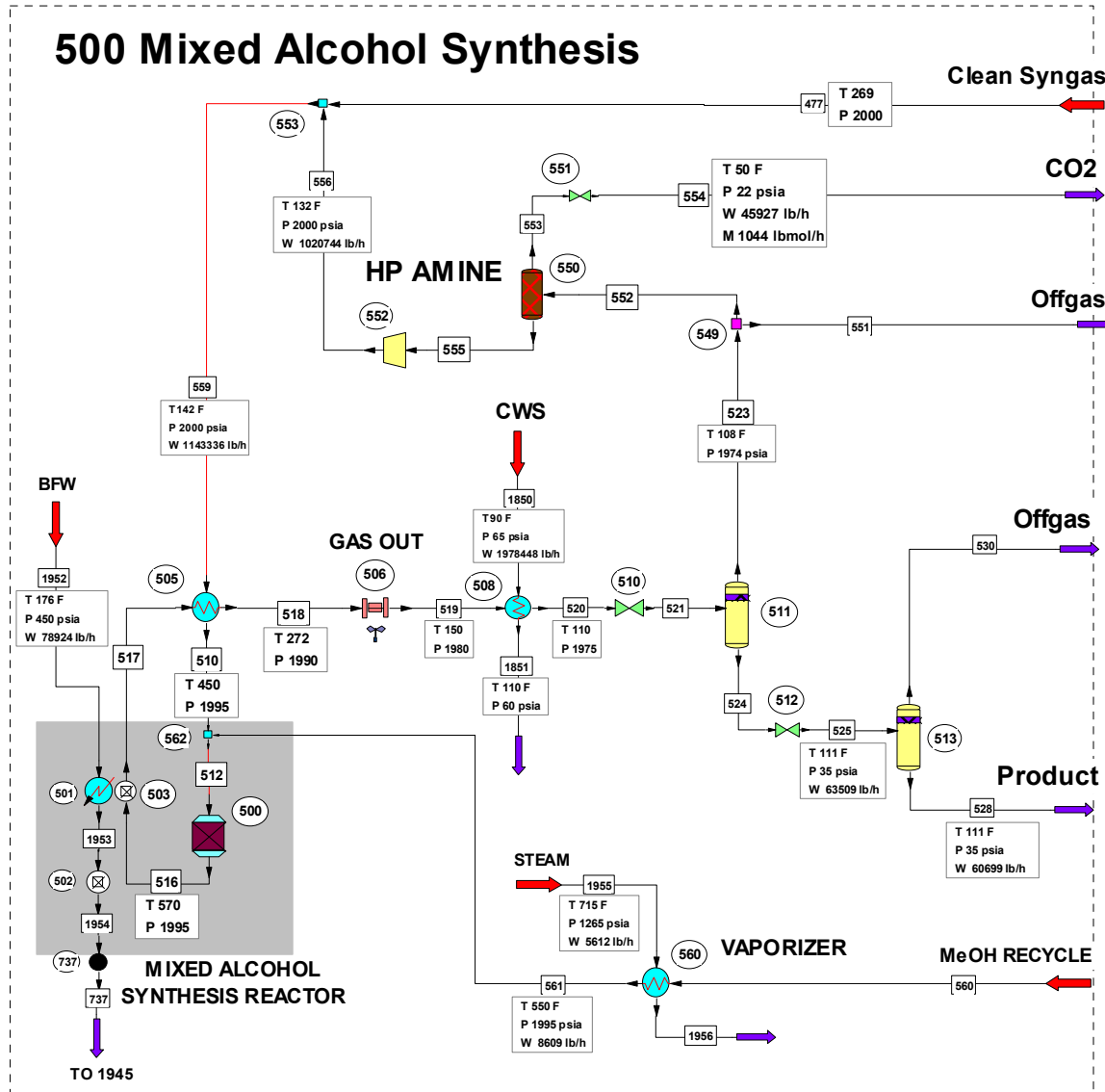

Figure B.5. Flow Sheet for Area 500 Mixed Alcohol Synthesis – Indirectly Heated Gasifier Base Case

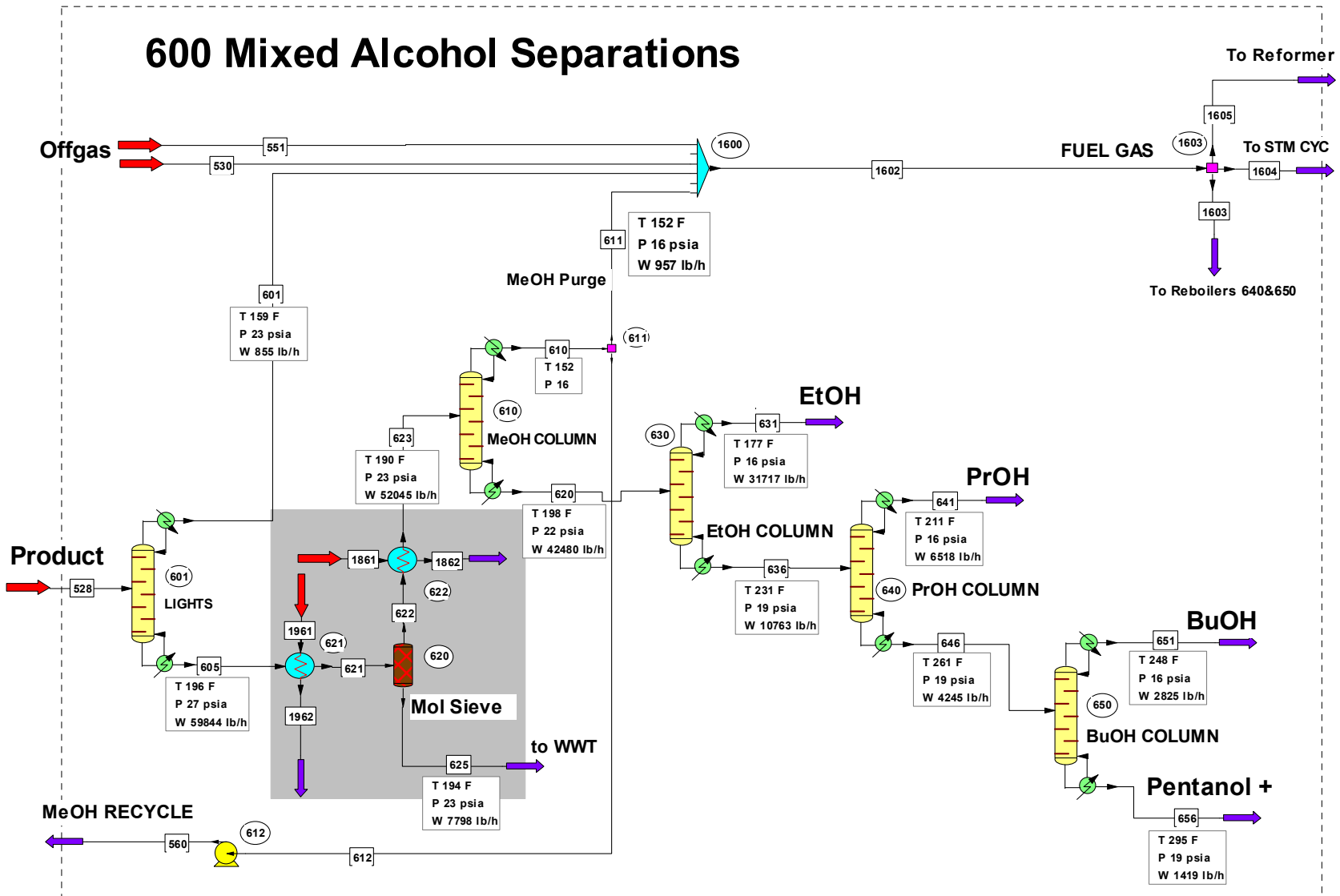

Figure B.6. Flow Sheet for Area 600 Mixed Alcohol Separation – Indirectly Heated Gasifier Base Case

B.7

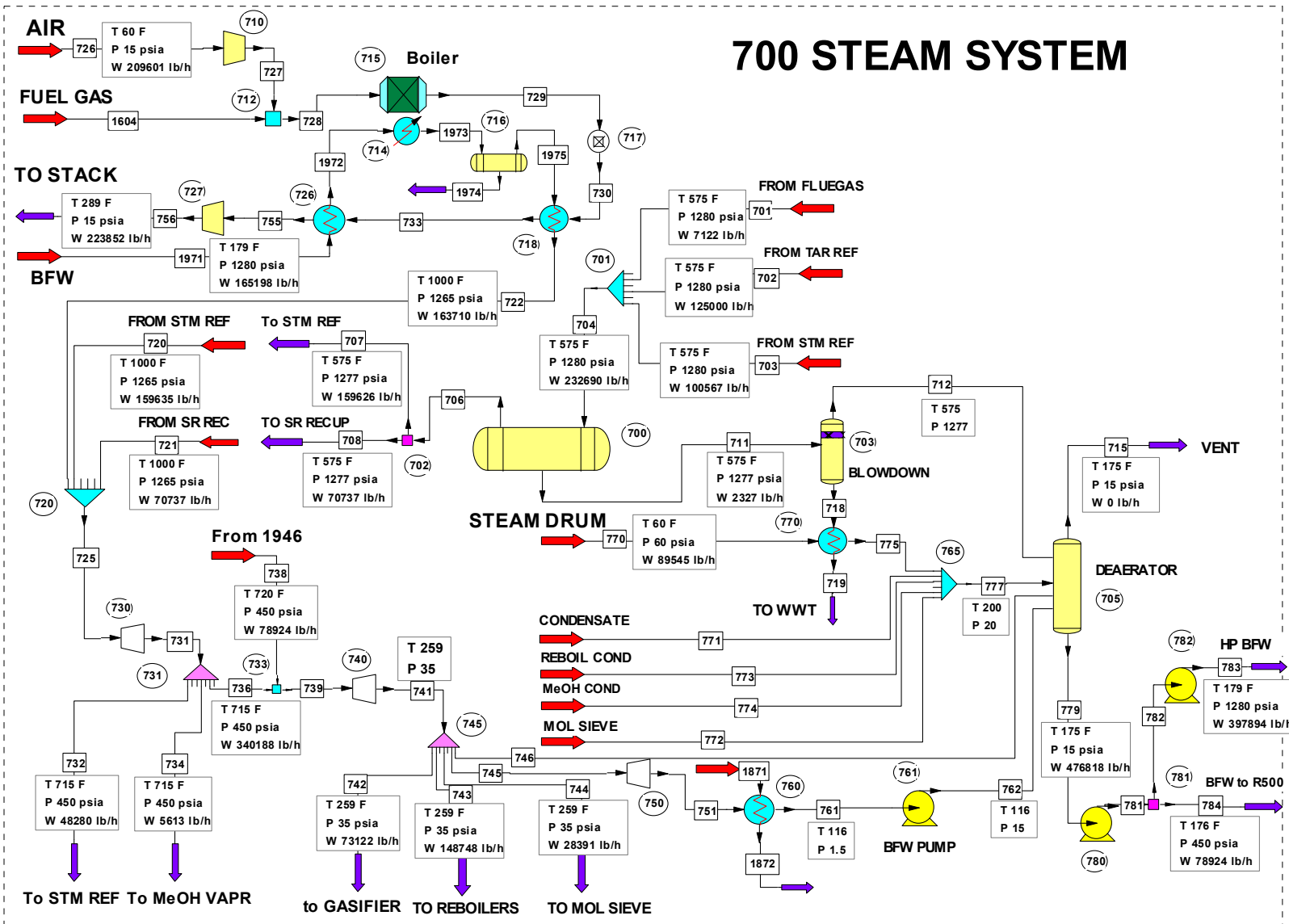

Figure B.7. Flow Sheet for Area 700 Steam System – Indirectly Heated Gasifier Base Case

Table B.1. Heat and Material Balances for the Indirectly Heated Gasifier Base Case

Stream No.	100	110	200	202	210	220	300	302	303	312	316	318	319	320
Temp F	60	172.5236	60	240.1082	240.1082	240.1082	259.3482	1675.4797	1598	1598	1800	1521.241	1800	1598
Pres psia	14.696	30	25	25	25	25	35	23	23	23	23	23	23	23
Enth MMBtu/h	-56.586	-40.388	-1744.9	-1549.6	-906.07	-643.52	-417.08	-9352.8	-9437	-8747.1	-8292.2	-8787.5	-8653.4	-689.85
Vapor mass fraction	0.99137	1	0	0.86363	1	0	1	1	1	1	0	1	1	1
Total lb/h	442163	442163	367437.406	367437.406	158664.734	208772.672	73120.0938	5268840.5	5268841	5025882.5	4986948	5468045.5	5468047.5	242958.406
Flowrates in lb/h														
Oxygen	100320.008	100320.008	0	0	0	0	0	0	3427.3118	3427.3118	0	103747.32	9939.2363	0
Nitrogen	327414	327414	0	0	0	0	0	0	0	0	0	327414	327393	0
Argon	5584	5584	0	0	0	0	0	0	0	0	0	5584	5584	0
Carbon	0	0	0	0	0	0	0	0	28194.9473	28194.9473	0	28194.9473	0.0012	0
Hydrogen	0	0	0	0	0	0	0	0	5458.3101	2351.679	0	2351.679	0.0007	3106.6311
Carbon Monoxide	0	0	0	0	0	0	0	0	76303.3672	0	0	0	0	76303.3672
Carbon Dioxide	218	218	0	0	0	0	0	0	36358.2422	0	0	218	103532.289	36358.2422
Methane	0	0	0	0	0	0	0	0	15913.6416	0	0	0	0	15913.6416
Acetylene	0	0	0	0	0	0	0	0	685.7475	0	0	0	0	685.7475
Ethylene	0	0	0	0	0	0	0	0	7877.7642	0	0	0	0	7877.7642
Ethane	0	0	0	0	0	0	0	0	566.7108	0	0	0	0	566.7108
Propane	0	0	0	0	0	0	0	0	0	0	0	0	0	0
Water	8627	8627	183718.703	183718.703	158664.734	25053.9629	73120.0938	98174.0625	98174.0625	0	0	8627	29644.9277	98174.0625
Sulphur	0	0	0	0	0	0	0	0	0	0	0	0	0	0
Carbonyl Sulfide	0	0	0	0	0	0	0	0	0	0	0	0	0	0
Hydrogen Sulfide	0	0	0	0	0	0	0	0	38.3004	0	0	0	0	38.3004
Ammonia	0	0	0	0	0	0	0	0	1358.2247	0	0	0	0	1358.2247
HydrogenChloride	0	0	0	0	0	0	0	0	18.5296	0	0	0	0	18.5296
Silicon Dioxide	0	0	0	0	0	0	0	0	4986948	4986948	4986948	4986948	4986948	0
Calcium Oxide	0	0	0	0	0	0	0	0	4960.4048	4960.4048	0	4960.4048	4960.4512	0
Benzene	0	0	0	0	0	0	0	0	639.3005	0	0	0	0	639.3005
Naphthalene	0	0	0	0	0	0	0	0	1917.9016	0	0	0	0	1917.9016
Hybrid Poplar Ch	0	0	183718.703	183718.703	0	183718.703	0	183718.703	0.0041	0.0041	0	0.0041	0	0
Sulfur Dioxide	0	0	0	0	0	0	0	0	0	0	0	0	0	0
Hydrogen Cyanide	0	0	0	0	0	0	0	0	0	0	0	0	0	0
Nitric Oxide	0	0	0	0	0	0	0	0	0	0	0	0	45.3622	0
Methanol	0	0	0	0	0	0	0	0	0	0	0	0	0	0
Ethanol	0	0	0	0	0	0	0	0	0	0	0	0	0	0
Isopropanol	0	0	0	0	0	0	0	0	0	0	0	0	0	0
N-Propanol	0	0	0	0	0	0	0	0	0	0	0	0	0	0
Isobutanol	0	0	0	0	0	0	0	0	0	0	0	0	0	0
N-Butanol	0	0	0	0	0	0	0	0	0	0	0	0	0	0
1-Pentanol	0	0	0	0	0	0	0	0	0	0	0	0	0	0

Table B.1. (contd)

Stream No.	100	110	200	202	210	220	300	302	303	312	316	318	319	320
Temp F	60	172.5236	60	240.1082	240.1082	240.1082	259.3482	1675.4797	1598	1598	1800	1521.241	1800	1598
Pres psia	14.696	30	25	25	25	25	35	23	23	23	23	23	23	23
Enth MMBtu/h	-56.586	-40.388	-1744.9	-1549.6	-906.07	-643.52	-417.08	-9352.8	-9437	-8747.1	-8292.2	-8787.5	-8653.4	-689.85
Vapor mass fraction	0.99137	1	0	0.86363	1	0	1	1	1	1	0	1	1	1
Total lb/h	442163	442163	367437.406	367437.406	158664.734	208772.672	73120.0938	5268840.5	5268841	5025882.5	4986948	5468045.5	5468047.5	242958.406
Flowrates in lb/h														
Oxygen	100320.008	100320.008	0	0	0	0	0	0	3427.3118	3427.3118	0	103747.32	9939.2363	0
Nitrogen	327414	327414	0	0	0	0	0	0	0	0	0	327414	327393	0
Argon	5584	5584	0	0	0	0	0	0	0	0	0	5584	5584	0
Carbon	0	0	0	0	0	0	0	0	28194.9473	28194.9473	0	28194.9473	0.0012	0
Hydrogen	0	0	0	0	0	0	0	0	5458.3101	2351.679	0	2351.679	0.0007	3106.6311
Carbon Monoxide	0	0	0	0	0	0	0	0	76303.3672	0	0	0	0	76303.3672
Carbon Dioxide	218	218	0	0	0	0	0	0	36358.2422	0	0	218	103532.289	36358.2422
Methane	0	0	0	0	0	0	0	0	15913.6416	0	0	0	0	15913.6416
Acetylene	0	0	0	0	0	0	0	0	685.7475	0	0	0	0	685.7475
Ethylene	0	0	0	0	0	0	0	0	7877.7642	0	0	0	0	7877.7642
Ethane	0	0	0	0	0	0	0	0	566.7108	0	0	0	0	566.7108
Propane	0	0	0	0	0	0	0	0	0	0	0	0	0	0
Water	8627	8627	183718.703	183718.703	158664.734	25053.9629	73120.0938	98174.0625	98174.0625	0	0	8627	29644.9277	98174.0625
Sulphur	0	0	0	0	0	0	0	0	0	0	0	0	0	0
Carbonyl Sulfide	0	0	0	0	0	0	0	0	0	0	0	0	0	0
Hydrogen Sulfide	0	0	0	0	0	0	0	0	38.3004	0	0	0	0	38.3004
Ammonia	0	0	0	0	0	0	0	0	1358.2247	0	0	0	0	1358.2247
Hydrogen Chloride	0	0	0	0	0	0	0	0	18.5296	0	0	0	0	18.5296
Silicon Dioxide	0	0	0	0	0	0	0	0	4986948	4986948	4986948	4986948	4986948	0
Calcium Oxide	0	0	0	0	0	0	0	0	4960.4048	4960.4048	0	4960.4048	4960.4512	0
Benzene	0	0	0	0	0	0	0	0	639.3005	0	0	0	0	639.3005
Naphthalene	0	0	0	0	0	0	0	0	1917.9016	0	0	0	0	1917.9016
Hybrid Poplar Ch	0	0	183718.703	183718.703	0	183718.703	0	183718.703	0.0041	0.0041	0	0.0041	0	0
Sulfur Dioxide	0	0	0	0	0	0	0	0	0	0	0	0	0	0
Hydrogen Cyanide	0	0	0	0	0	0	0	0	0	0	0	0	0	0
Nitric Oxide	0	0	0	0	0	0	0	0	0	0	0	0	45.3622	0
Methanol	0	0	0	0	0	0	0	0	0	0	0	0	0	0
Ethanol	0	0	0	0	0	0	0	0	0	0	0	0	0	0
Isopropanol	0	0	0	0	0	0	0	0	0	0	0	0	0	0
N-Propanol	0	0	0	0	0	0	0	0	0	0	0	0	0	0
Isobutanol	0	0	0	0	0	0	0	0	0	0	0	0	0	0
N-Butanol	0	0	0	0	0	0	0	0	0	0	0	0	0	0
1-Pentanol	0	0	0	0	0	0	0	0	0	0	0	0	0	0

Table B.1. (contd)

Stream No.	100	110	200	202	210	220	300	302	303	312	316	318	319	320
Temp F	60	172.5236	60	240.1082	240.1082	240.1082	259.3482	1675.4797	1598	1598	1800	1521.241	1800	1598
Pres psia	14.696	30	25	25	25	25	35	23	23	23	23	23	23	23
Enth MMBtu/h	-56.586	-40.388	-1744.9	-1549.6	-906.07	-643.52	-417.08	-9352.8	-9437	-8747.1	-8292.2	-8787.5	-8653.4	-689.85
Vapor mass fraction	0.99137	1	0	0.86363	1	0	1	1	1	1	0	1	1	1
Total lb/h	442163	442163	367437.406	367437.406	158664.734	208772.672	73120.0938	5268840.5	5268841	5025882.5	4986948	5468045.5	5468047.5	242958.406
Flowrates in lb/h														
Oxygen	100320.008	100320.008	0	0	0	0	0	0	3427.3118	3427.3118	0	103747.32	9939.2363	0
Nitrogen	327414	327414	0	0	0	0	0	0	0	0	0	327414	327393	0
Argon	5584	5584	0	0	0	0	0	0	0	0	0	5584	5584	0
Carbon	0	0	0	0	0	0	0	0	28194.9473	28194.9473	0	28194.9473	0.0012	0
Hydrogen	0	0	0	0	0	0	0	0	5458.3101	2351.679	0	2351.679	0.0007	3106.6311
Carbon Monoxide	0	0	0	0	0	0	0	0	76303.3672	0	0	0	0	76303.3672
Carbon Dioxide	218	218	0	0	0	0	0	0	36358.2422	0	0	218	103532.289	36358.2422
Methane	0	0	0	0	0	0	0	0	15913.6416	0	0	0	0	15913.6416
Acetylene	0	0	0	0	0	0	0	0	685.7475	0	0	0	0	685.7475
Ethylene	0	0	0	0	0	0	0	0	7877.7642	0	0	0	0	7877.7642
Ethane	0	0	0	0	0	0	0	0	566.7108	0	0	0	0	566.7108
Propane	0	0	0	0	0	0	0	0	0	0	0	0	0	0
Water	8627	8627	183718.703	183718.703	158664.734	25053.9629	73120.0938	98174.0625	98174.0625	0	0	8627	29644.9277	98174.0625
Sulphur	0	0	0	0	0	0	0	0	0	0	0	0	0	0
Carbonyl Sulfide	0	0	0	0	0	0	0	0	0	0	0	0	0	0
Hydrogen Sulfide	0	0	0	0	0	0	0	0	38.3004	0	0	0	0	38.3004
Ammonia	0	0	0	0	0	0	0	0	1358.2247	0	0	0	0	1358.2247
HydrogenChloride	0	0	0	0	0	0	0	0	18.5296	0	0	0	0	18.5296
Silicon Dioxide	0	0	0	0	0	0	0	0	4986948	4986948	4986948	4986948	4986948	0
Calcium Oxide	0	0	0	0	0	0	0	0	4960.4048	4960.4048	0	4960.4048	4960.4512	0
Benzene	0	0	0	0	0	0	0	0	639.3005	0	0	0	0	639.3005
Naphthalene	0	0	0	0	0	0	0	0	1917.9016	0	0	0	0	1917.9016
Hybrid Poplar Ch	0	0	183718.703	183718.703	0	183718.703	0	183718.703	0.0041	0.0041	0	0.0041	0	0
Sulfur Dioxide	0	0	0	0	0	0	0	0	0	0	0	0	0	0
Hydrogen Cyanide	0	0	0	0	0	0	0	0	0	0	0	0	0	0
Nitric Oxide	0	0	0	0	0	0	0	0	0	0	0	0	45.3622	0
Methanol	0	0	0	0	0	0	0	0	0	0	0	0	0	0
Ethanol	0	0	0	0	0	0	0	0	0	0	0	0	0	0
Isopropanol	0	0	0	0	0	0	0	0	0	0	0	0	0	0
N-Propanol	0	0	0	0	0	0	0	0	0	0	0	0	0	0
Isobutanol	0	0	0	0	0	0	0	0	0	0	0	0	0	0
N-Butanol	0	0	0	0	0	0	0	0	0	0	0	0	0	0
1-Pentanol	0	0	0	0	0	0	0	0	0	0	0	0	0	0

Table B.1. (contd)

Stream No.	430	431	432	433	434	435	440	441	442	445	446	447	448	449
Temp F	120	120	120	707	707	707	699.2361	900	1652	1199.951	1071.6383	250	150	110
Pres psia	465	445	445	445	682	682	440	435	420	420	420	420	420	417.5
Enth MMBtu/h	-323.82	0	-323.8	-284.05	-0.0039727	-283.97	-598.63	-578.52	-477.68	-528.02	-541.77	-645.73	-668.71	-674.35
Vapor mass fraction	1	0	1	1	1	1	1	1	1	1	1	0.89505	0.83868	0.83361
Total lb/h	157674.781	0	157674.781	157674.781	37.8475	157637	219120.125	219120.125	219120.469	219120.469	219120.469	219120.469	219120.469	219120.469
Flowrates in lb/h														
Oxygen	0	0	0	0	0	0	0	0	0	0	0	0	0	0
Nitrogen	781.9396	0	781.9396	781.9396	0	781.9396	781.9396	781.9396	976.8055	976.8055	976.8055	976.8055	976.8055	976.8055
Argon	0	0	0	0	0	0	0	0	0	0	0	0	0	0
Carbon	0	0	0	0	0	0	0	0	0	0	0	0	0	0
Hydrogen	6362.9224	0	6362.9224	6362.9224	0	6362.9224	6362.9224	6362.9224	8615.5762	8615.5762	8615.5762	8615.5762	8615.5762	8615.5762
Carbon Monoxide	96357.4766	0	96357.4766	96357.4766	0	96357.4766	96357.4766	96357.4766	100748.828	100748.828	100748.828	100748.828	100748.828	100748.828
Carbon Dioxide	36047.4688	0	36047.4688	36047.4688	0	36047.4688	49250.4648	49250.4648	60059.4336	60059.4336	60059.4336	60059.4336	60059.4336	60059.4336
Methane	12730.8164	0	12730.8164	12730.8164	0	12730.8164	12730.8164	12730.8164	11616.4678	11616.4678	11616.4678	11616.4678	11616.4678	11616.4678
Acetylene	342.8701	0	342.8701	342.8701	0	342.8701	342.8701	342.8701	0.0034	0.0034	0.0034	0.0034	0.0034	0.0034
Ethylene	3938.7883	0	3938.7883	3938.7883	0	3938.7883	3938.7883	3938.7883	0.8319	0.8319	0.8319	0.8319	0.8319	0.8319
Ethane	56.6707	0	56.6707	56.6707	0	56.6707	56.6707	56.6707	2.0757	2.0757	2.0757	2.0757	2.0757	2.0757
Propane	0	0	0	0	0	0	0	0	0	0	0	0	0	0
Water	458.8869	0	458.8869	458.8869	0	458.8869	48739.082	48739.082	37065.7852	37065.7852	37065.7852	37065.7852	37065.7852	37065.7852
Sulphur	0	0	0	0	0	0	0	0	0	0	0	0	0	0
Carbonyl Sulfide	0	0	0	0	0	0	0	0	0	0	0	0	0	0
Hydrogen Sulfide	37.8475	0	37.8475	37.8475	37.8475	0	0	0	0	0	0	0	0	0
Ammonia	252.8876	0	252.8876	252.8876	0	252.8876	252.8876	252.8876	15.7244	15.7244	15.7244	15.7244	15.7244	15.7244
HydrogenChloride	18.5275	0	18.5275	18.5275	0	18.5275	18.5275	18.5275	18.5275	18.5275	18.5275	18.5275	18.5275	18.5275
Silicon Dioxide	0	0	0	0	0	0	0	0	0	0	0	0	0	0
Calcium Oxide	0	0	0	0	0	0	0	0	0	0	0	0	0	0
Benzene	191.7865	0	191.7865	191.7865	0	191.7865	191.7865	191.7865	0	0	0	0	0	0
Naphthalene	95.8937	0	95.8937	95.8937	0	95.8937	95.8937	95.8937	0	0	0	0	0	0
Hybrid Poplar Ch	0	0	0	0	0	0	0	0	0	0	0	0	0	0
Sulfur Dioxide	0	0	0	0	0	0	0	0	0	0	0	0	0	0
Hydrogen Cyanide	0	0	0	0	0	0	0	0	0.3646	0.3646	0.3646	0.3646	0.3646	0.3646
Nitric Oxide	0	0	0	0	0	0	0	0	0	0	0	0	0	0
Methanol	0	0	0	0	0	0	0	0	0.0624	0.0624	0.0624	0.0624	0.0624	0.0624
Ethanol	0	0	0	0	0	0	0	0	0	0	0	0	0	0
Isopropanol	0	0	0	0	0	0	0	0	0	0	0	0	0	0
N-Propanol	0	0	0	0	0	0	0	0	0	0	0	0	0	0
Isobutanol	0	0	0	0	0	0	0	0	0	0	0	0	0	0
N-Butanol	0	0	0	0	0	0	0	0	0	0	0	0	0	0
1-Pentanol	0	0	0	0	0	0	0	0	0	0	0	0	0	0

Table B.1. (contd)

Stream No.	450	451	452	453	454	455	471	472	473	474	477	490	491	493
Temp F	110	120	120	58.8714	120	661.8597	240.1355	150	276.2284	150	269.3795	60	124.5558	111.1681
Pres psia	417.5	412.5	412.5	22	22	440	700	700	1200	1200	2000	14.696	20	16
Enth MMBtu/h	-426.69	-194.07	-232.69	-232.69	-50.645	-48.97	-186.51	-192.23	-184.14	-192.29	-184.45	-0.71369	1.939	-22.189
Vapor mass fraction	1	1	0.99164	0.9945	1	1	1	1	1	1	1	1	1	1
Total lb/h	182661.719	122595.859	60065.8789	60065.8789	13203	13203	122595.859	122595.859	122595.859	122595.859	122596	170009.438	170009.438	181568.484
Flowrates in lb/h														
Oxygen	0	0	0	0	0	0	0	0	0	0	0	39597.6523	39597.6523	39597.6523
Nitrogen	976.8055	976.8055	0	0	0	0	976.8055	976.8055	976.8055	976.8055	976.8058	130411.789	130411.789	130839.563
Argon	0	0	0	0	0	0	0	0	0	0	0	0	0	0
Carbon	0	0	0	0	0	0	0	0	0	0	0	0	0	0
Hydrogen	8615.5762	8615.5762	0	0	0	0	8615.5762	8615.5762	8615.5762	8615.5762	8615.5791	0	0	83.7534
Carbon Monoxide	100748.828	100748.828	0	0	0	0	100748.828	100748.828	100748.828	100748.828	100748.852	0	0	1189.1895
Carbon Dioxide	60059.4336	600.5925	59458.8398	59458.8398	13203	13203	600.5925	600.5925	600.5925	600.5925	600.5927	0	0	787.2261
Methane	11616.4668	11616.4668	0	0	0	0	11616.4668	11616.4668	11616.4668	11616.4668	11616.4717	0	0	7692.0977
Acetylene	0.0034	0.0034	0	0	0	0	0.0034	0.0034	0.0034	0.0034	0.0034	0	0	0.0015
Ethylene	0.8319	0.8319	0	0	0	0	0.8319	0.8319	0.8319	0.8319	0.8319	0	0	0.3643
Ethane	2.0757	2.0757	0	0	0	0	2.0757	2.0757	2.0757	2.0757	2.0757	0	0	272.0825
Propane	0	0	0	0	0	0	0	0	0	0	0	0	0	0
Water	607.0382	0	607.0382	607.0391	0	0	0	0	0	0	0	0	0	56.815
Sulphur	0	0	0	0	0	0	0	0	0	0	0	0	0	0
Carbonyl Sulfide	0	0	0	0	0	0	0	0	0	0	0	0	0	0
Hydrogen Sulfide	0	0	0	0	0	0	0	0	0	0	0	0	0	0
Ammonia	15.7244	15.7244	0	0	0	0	15.7244	15.7244	15.7244	15.7244	15.7244	0	0	6.8868
Hydrogen Chloride	18.5275	18.5275	0	0	0	0	18.5275	18.5275	18.5275	18.5275	18.5275	0	0	8.1143
Silicon Dioxide	0	0	0	0	0	0	0	0	0	0	0	0	0	0
Calcium Oxide	0	0	0	0	0	0	0	0	0	0	0	0	0	0
Benzene	0	0	0	0	0	0	0	0	0	0	0	0	0	0
Naphthalene	0	0	0	0	0	0	0	0	0	0	0	0	0	0
Hybrid Poplar Ch	0	0	0	0	0	0	0	0	0	0	0	0	0	0
Sulfur Dioxide	0	0	0	0	0	0	0	0	0	0	0	0	0	0
Hydrogen Cyanide	0.3646	0.3646	0	0	0	0	0.3646	0.3646	0.3646	0.3646	0.3646	0	0	0.1597
Nitric Oxide	0	0	0	0	0	0	0	0	0	0	0	0	0	0
Methanol	0.0624	0.0624	0	0	0	0	0.0624	0.0624	0.0624	0.0624	0.0624	0	0	725.4853
Ethanol	0	0	0	0	0	0	0	0	0	0	0	0	0	277.3153
Isopropanol	0	0	0	0	0	0	0	0	0	0	0	0	0	0
N-Propanol	0	0	0	0	0	0	0	0	0	0	0	0	0	23.918
Isobutanol	0	0	0	0	0	0	0	0	0	0	0	0	0	0
N-Butanol	0	0	0	0	0	0	0	0	0	0	0	0	0	5.3214
1-Pentanol	0	0	0	0	0	0	0	0	0	0	0	0	0	2.5555

Table B.1. (contd)

Stream No.	494	495	496	497	498	499	510	512	516	517	518	519	520	521
Temp F	1800	1800	1452.6448	1051.1208	263.0359	280.8753	450	449.219	570	570	272.0092	150	110	109.9836
Pres psia	16	16	14	14	14	15	1995	1995	1995	1995	1990	1980	1975	1974
Enth MMBtu/h	-122.9	-122.9	-143.01	-165.31	-205.71	-204.84	-1854.3	-1877.3	-1960.3	-1960.3	-2186.5	-2288.1	-2327.7	-2327.7
Vapor mass fraction	1	1	1	1	1	1	1	1	1	1	1	0.97467	0.9489	0.94889
Total lb/h	181568.125	181568.125	181568.109	181568.109	181568.109	181568.109	1143346.25	1151954.88	1151956.88	1151956.88	1151956.88	1151957.5	1151957.5	1151957.5
Flowrates in lb/h														
Oxygen	4790.6025	4790.6025	4790.6812	4790.6812	4790.6812	4790.6812	0	0	0	0	0	0	0	0
Nitrogen	130836.023	130836.023	130836.023	130836.023	130836.023	130836.023	48093.3984	48093.4063	48093.3984	48093.3984	48093.3984	48093.6445	48093.6445	48093.6445
Argon	0	0	0	0	0	0	0	0	0	0	0	0	0	0
Carbon	0	0	0	0	0	0	0	0	0	0	0	0	0	0
Hydrogen	0.0005	0.0005	0.0005	0.0005	0.0005	0.0005	17838.5898	17838.5879	9414.7617	9414.7617	9414.7617	9414.8916	9414.8916	9414.8906
Carbon Monoxide	0.0065	0.0065	0.0065	0.0065	0.0065	0.0065	230705	230705	132671.219	132671.219	132671.219	132671.219	132671.219	132671.219
Carbon Dioxide	26153.0293	26153.0293	26153.0078	26153.0078	26153.0078	26153.0078	1064.4969	1064.4974	48188.1016	48188.1016	48188.1016	48188.0938	48188.0938	48188.0938
Methane	0.0001	0.0001	0.0001	0.0001	0.0001	0.0001	803321	803321.063	809267.125	809267.125	809267.125	809268	809268	809268
Acetylene	0.0002	0.0002	0.0002	0.0002	0.0002	0.0002	0.1016	0.1016	0.1016	0.1016	0.1016	0.1016	0.1016	0.1016
Ethylene	0.0002	0.0002	0.0002	0.0002	0.0002	0.0002	31.6019	31.6019	31.6019	31.6019	31.6019	31.6019	31.6019	31.6019
Ethane	0.0002	0.0002	0.0002	0.0002	0.0002	0.0002	21797.5996	21797.6055	22416.7754	22416.7754	22416.7754	22416.8047	22416.8047	22416.8027
Propane	0	0	0	0	0	0	0	0	0	0	0	0	0	0
Water	19760.4512	19760.4512	19760.3809	19760.3809	19760.3809	19760.3809	2121.2881	2121.2876	10049.4492	10049.4492	10049.4492	10049.4385	10049.4385	10049.4434
Sulphur	0	0	0	0	0	0	0	0	0	0	0	0	0	0
Carbonyl Sulfide	0	0	0	0	0	0	0	0	0	0	0	0	0	0
Hydrogen Sulfide	0	0	0	0	0	0	0	0	0	0	0	0	0	0
Ammonia	0.0001	0.0001	0.0001	0.0001	0.0001	0.0001	135.2894	135.2895	135.2894	135.2894	135.2894	135.2892	135.2892	135.2892
HydrogenChloride	8.1143	8.1143	8.1143	8.1143	8.1143	8.1143	423.6196	423.6195	423.6194	423.6194	423.6194	423.6199	423.6199	423.6199
Silicon Dioxide	0	0	0	0	0	0	0	0	0	0	0	0	0	0
Calcium Oxide	0	0	0	0	0	0	0	0	0	0	0	0	0	0
Benzene	0	0	0	0	0	0	0	0	0	0	0	0	0	0
Naphthalene	0	0	0	0	0	0	0	0	0	0	0	0	0	0
Hybrid Poplar Ch	0	0	0	0	0	0	0	0	0	0	0	0	0	0
Sulfur Dioxide	0	0	0	0	0	0	0	0	0	0	0	0	0	0
Hydrogen Cyanide	0.0002	0.0002	0.0002	0.0002	0.0002	0.0002	1.6536	1.6536	1.6536	1.6536	1.6536	1.6536	1.6536	1.6536
Nitric Oxide	19.9106	19.9106	19.9107	19.9107	19.9107	19.9107	0	0	0	0	0	0	0	0
Methanol	0.0002	0.0002	0.0002	0.0002	0.0002	0.0002	4102.417	12682.3389	14434.9648	14434.9648	14434.9648	14434.96	14434.96	14434.9648
Ethanol	0.0003	0.0003	0.0003	0.0003	0.0003	0.0003	11737.46	11765.9209	43970.3516	43970.3516	43970.3516	43970.2656	43970.2656	43970.2852
Isopropanol	0	0	0	0	0	0	0	0	0	0	0	0	0	0
N-Propanol	0.0003	0.0003	0.0003	0.0003	0.0003	0.0003	1424.261	1424.4114	8039.2651	8039.2651	8039.2651	8039.2549	8039.2549	8039.2598
Isobutanol	0	0	0	0	0	0	0	0	0	0	0	0	0	0
N-Butanol	0.0004	0.0004	0.0004	0.0004	0.0004	0.0004	360.2054	360.2055	3206.7107	3206.7107	3206.7107	3206.7078	3206.7078	3206.7092
1-Pentanol	0.0004	0.0004	0.0004	0.0004	0.0004	0.0004	188.5102	188.5102	1612.3611	1612.3611	1612.3611	1612.3596	1612.3596	1612.3606

Table B.1. (contd)

Stream No.	523	524	525	528	530	551	552	553	554	555	556	559	560	561
Temp F	107.9549	107.9549	110.8222	110.8216	110.8216	107.9549	107.9549	230	49.7944	130	132.2388	141.7071	189.1983	550
Pres psia	1974	1974	35	35	35	1974	1974	1974	22	1974	2000	2000	2000	1995
Enth MMBtu/h	-2130.7	-197.02	-197.02	-189.94	-7.0817	-42.613	-2088	-176.83	-176.83	-1897.2	-1896.1	-2080.5	-27.085	-22.971
Vapor mass fraction	1	0	0.044242	0	1	1	1	1	1	1	1	1	0	1
Total lb/h	1088448.88	63508.6484	63508.6484	60698.9102	2809.7424	21768.9746	1066679.88	45926.8711	45926.8711	1020752.75	1020753	1143346.25	8608.5234	8608.5234
Flowrates in lb/h														
Oxygen	0	0	0	0	0	0	0	0	0	0	0	0	0	0
Nitrogen	48078.5508	15.0906	15.0906	0.0344	15.0562	961.571	47117	0	0	47117	47117	48093.3984	0	0
Argon	0	0	0	0	0	0	0	0	0	0	0	0	0	0
Carbon	0	0	0	0	0	0	0	0	0	0	0	0	0	0
Hydrogen	9411.9102	2.9797	2.9797	0.0063	2.9734	188.2382	9223.6719	0	0	9223.6699	9223.6719	17838.5898	0	0
Carbon Monoxide	132608.375	62.8775	62.8775	0.2336	62.6439	2652.1672	129956.195	0	0	129956.117	129956.211	230705	0	0
Carbon Dioxide	47337.5273	850.5696	850.5696	169.2234	681.3462	946.7506	46390.7773	45926.8711	45926.8711	463.9044	463.9045	1064.4969	0	0
Methane	807863	1404.6102	1404.6102	23.9136	1380.6965	16157.2578	791706	0	0	791706	791706	803321	0	0
Acetylene	0.1002	0.0014	0.0014	0.0002	0.0011	0.002	0.0982	0	0	0.0982	0.0982	0.1016	0	0
Ethylene	31.3981	0.2039	0.2039	0.017	0.1869	0.628	30.7701	0	0	30.7701	30.7701	31.6019	0	0
Ethane	22240.418	176.3845	176.3845	19.2415	157.1431	444.8083	21795.6113	0	0	21795.6016	21795.6113	21797.5996	0	0
Propane	0	0	0	0	0	0	0	0	0	0	0	0	0	0
Water	2164.5823	7884.8535	7884.853	7804.6665	80.1865	43.2916	2121.2908	0	0	2121.2913	2121.2915	2121.2881	0	0
Sulphur	0	0	0	0	0	0	0	0	0	0	0	0	0	0
Carbonyl Sulfide	0	0	0	0	0	0	0	0	0	0	0	0	0	0
Hydrogen Sulfide	0	0	0	0	0	0	0	0	0	0	0	0	0	0
Ammonia	122.006	13.2833	13.2833	8.6993	4.584	2.4401	119.5659	0	0	119.5659	119.5659	135.2894	0	0
HydrogenChloride	413.3613	10.2586	10.2586	2.7101	7.5485	8.2672	405.0941	0	0	405.094	405.0941	423.6196	0	0
Silicon Dioxide	0	0	0	0	0	0	0	0	0	0	0	0	0	0
Calcium Oxide	0	0	0	0	0	0	0	0	0	0	0	0	0	0
Benzene	0	0	0	0	0	0	0	0	0	0	0	0	0	0
Naphthalene	0	0	0	0	0	0	0	0	0	0	0	0	0	0
Hybrid Poplar Ch	0	0	0	0	0	0	0	0	0	0	0	0	0	0
Sulfur Dioxide	0	0	0	0	0	0	0	0	0	0	0	0	0	0
Hydrogen Cyanide	1.3153	0.3383	0.3383	0.3012	0.0371	0.0263	1.289	0	0	1.289	1.289	1.6536	0	0
Nitric Oxide	0	0	0	0	0	0	0	0	0	0	0	0	0	0
Methanol	4186.0835	10248.8721	10248.8721	10136.3818	112.4901	83.7217	4102.3623	0	0	4102.3608	4102.3633	4102.417	8579.918	8579.918
Ethanol	11977.0039	31993.25	31993.25	31720.709	272.5431	239.5401	11737.4639	0	0	11737.4512	11737.4648	11737.46	28.455	28.455
Isopropanol	0	0	0	0	0	0	0	0	0	0	0	0	0	0
N-Propanol	1453.3259	6585.9272	6585.9268	6560.4063	25.5206	29.0665	1424.2594	0	0	1424.2593	1424.2595	1424.261	0.1499	0.1499
Isobutanol	0	0	0	0	0	0	0	0	0	0	0	0	0	0
N-Butanol	367.5562	2839.1504	2839.1501	2834.3521	4.7981	7.3511	360.2051	0	0	360.205	360.2051	360.2054	0	0
1-Pentanol	192.3572	1420.002	1420.0017	1418.0146	1.9873	3.8471	188.5101	0	0	188.51	188.5101	188.5102	0	0

Table B.1. (contd)

Stream No.	601	605	610	611	612	620	621	622	623	625	631	636	641	646
Temp F	159.3249	195.6385	152.0264	152.0264	152.0264	197.9349	194.2095	194.2095	189.6988	194.2095	176.764	230.7707	210.9613	261.081
Pres psia	23	26.7	16	16	16	22	26.7	23	23	23	16	19	16	19
Enth MMBtu/h	-2.3742	-183.06	-30.188	-3.0188	-27.169	-100.7	-156.42	-130.54	-131	-52.256	-80.108	-20.819	-13.529	-7.287
Vapor mass fraction	1	0	0	0	0	0	1	0.0094024	2.19E-05	0	0	0	0	0
Total lb/h	855.3384	59843.5703	9565.0264	956.5026	8608.5234	42480.1172	59843.5703	52045.1406	52045.1445	7798.4302	31717.2129	10762.9033	6518.2212	4244.6831
Flowrates in lb/h														
Oxygen	0	0	0	0	0	0	0	0	0	0	0	0	0	0
Nitrogen	0.0344	0	0	0	0	0	0	0	0	0	0	0	0	0
Argon	0	0	0	0	0	0	0	0	0	0	0	0	0	0
Carbon	0	0	0	0	0	0	0	0	0	0	0	0	0	0
Hydrogen	0.0063	0	0	0	0	0	0	0	0	0	0	0	0	0
Carbon Monoxide	0.2336	0	0	0	0	0	0	0	0	0	0	0	0	0
Carbon Dioxide	169.2234	0	0	0	0	0	0	0	0	0	0	0	0	0
Methane	23.9136	0	0	0	0	0	0	0	0	0	0	0	0	0
Acetylene	0.0002	0	0	0	0	0	0	0	0	0	0	0	0	0
Ethylene	0.017	0	0	0	0	0	0	0	0	0	0	0	0	0
Ethane	19.2415	0	0	0	0	0	0	0	0	0	0	0	0	0
Propane	0	0	0	0	0	0	0	0	0	0	0	0	0	0
Water	6.2364	7798.4302	0	0	0	0	7798.4302	0	0	7798.4302	0	0	0	0
Sulphur	0	0	0	0	0	0	0	0	0	0	0	0	0	0
Carbonyl Sulfide	0	0	0	0	0	0	0	0	0	0	0	0	0	0
Hydrogen Sulfide	0	0	0	0	0	0	0	0	0	0	0	0	0	0
Ammonia	8.6993	0	0	0	0	0	0	0	0	0	0	0	0	0
HydrogenChloride	2.7101	0	0	0	0	0	0	0	0	0	0	0	0	0
Silicon Dioxide	0	0	0	0	0	0	0	0	0	0	0	0	0	0
Calcium Oxide	0	0	0	0	0	0	0	0	0	0	0	0	0	0
Benzene	0	0	0	0	0	0	0	0	0	0	0	0	0	0
Naphthalene	0	0	0	0	0	0	0	0	0	0	0	0	0	0
Hybrid Poplar Ch	0	0	0	0	0	0	0	0	0	0	0	0	0	0
Sulfur Dioxide	0	0	0	0	0	0	0	0	0	0	0	0	0	0
Hydrogen Cyanide	0.3012	0	0	0	0	0	0	0	0	0	0	0	0	0
Nitric Oxide	0	0	0	0	0	0	0	0	0	0	0	0	0	0
Methanol	506.8231	9629.5586	9533.2432	953.3243	8579.918	96.3157	9629.5586	9629.5586	9629.5596	0	96.1896	0.126	0.126	0.0001
Ethanol	117.8949	31602.8145	31.6166	3.1617	28.455	31571.1973	31602.8145	31602.8145	31602.8145	0	31555.4355	15.7626	15.7626	0
Isopropanol	0	0	0	0	0	0	0	0	0	0	0	0	0	0
N-Propanol	0.0036	6560.4023	0.1666	0.0167	0.1499	6560.2358	6560.4023	6560.4023	6560.4038	0	65.5874	6494.6484	6488.1592	6.4894
Isobutanol	0	0	0	0	0	0	0	0	0	0	0	0	0	0
N-Butanol	0	2834.3521	0	0	0	2834.3521	2834.3521	2834.3521	2834.3518	0	0	2834.3521	14.1727	2820.1794
1-Pentanol	0	1418.0146	0	0	0	1418.0146	1418.0146	1418.0146	1418.0144	0	0	1418.0146	0.0004	1418.0143

Table B.1. (contd)

Stream No.	651	656	701	702	703	704	706	707	708	711	712	715	718	719
Temp F	248.4839	294.7396	575.2682	575.2682	575.2682	575.2665	575	575	575	575	574.9981	174.5574	574.9981	150
Pres psia	16	19	1280	1280	1280	1280	1277.3452	1277.3452	1277.3452	1277.3452	1277.3452	15	1277.3452	1277.3452
Enth MMBtu/h	-5.0279	-2.2484	-40.523	-711.23	-572.22	-1324	-1310.7	-908.23	-402.48	-14.625	0	0	-14.625	-15.713
Vapor mass fraction	0	0	1	1	1	1	1	1	1	0	1	1	0	0
Total lb/h	2825.2676	1419.4158	7121.9355	125000	100568.242	232689.375	230362.484	159625.469	70737	2326.8906	0	0	2326.8906	2326.8906
Flowrates in lb/h														
Oxygen	0	0	0	0	0	0	0	0	0	0	0	0	0	0
Nitrogen	0	0	0	0	0	0	0	0	0	0	0	0	0	0
Argon	0	0	0	0	0	0	0	0	0	0	0	0	0	0
Carbon	0	0	0	0	0	0	0	0	0	0	0	0	0	0
Hydrogen	0	0	0	0	0	0	0	0	0	0	0	0	0	0
Carbon Monoxide	0	0	0	0	0	0	0	0	0	0	0	0	0	0
Carbon Dioxide	0	0	0	0	0	0	0	0	0	0	0	0	0	0
Methane	0	0	0	0	0	0	0	0	0	0	0	0	0	0
Acetylene	0	0	0	0	0	0	0	0	0	0	0	0	0	0
Ethylene	0	0	0	0	0	0	0	0	0	0	0	0	0	0
Ethane	0	0	0	0	0	0	0	0	0	0	0	0	0	0
Propane	0	0	0	0	0	0	0	0	0	0	0	0	0	0
Water	0	0	7121.9355	125000	100568.242	232689.375	230362.484	159625.469	70737	2326.8906	0	0	2326.8906	2326.8906
Sulphur	0	0	0	0	0	0	0	0	0	0	0	0	0	0
Carbonyl Sulfide	0	0	0	0	0	0	0	0	0	0	0	0	0	0
Hydrogen Sulfide	0	0	0	0	0	0	0	0	0	0	0	0	0	0
Ammonia	0	0	0	0	0	0	0	0	0	0	0	0	0	0
HydrogenChloride	0	0	0	0	0	0	0	0	0	0	0	0	0	0
Silicon Dioxide	0	0	0	0	0	0	0	0	0	0	0	0	0	0
Calcium Oxide	0	0	0	0	0	0	0	0	0	0	0	0	0	0
Benzene	0	0	0	0	0	0	0	0	0	0	0	0	0	0
Naphthalene	0	0	0	0	0	0	0	0	0	0	0	0	0	0
Hybrid Poplar Ch	0	0	0	0	0	0	0	0	0	0	0	0	0	0
Sulfur Dioxide	0	0	0	0	0	0	0	0	0	0	0	0	0	0
Hydrogen Cyanide	0	0	0	0	0	0	0	0	0	0	0	0	0	0
Nitric Oxide	0	0	0	0	0	0	0	0	0	0	0	0	0	0
Methanol	0.0001	0	0	0	0	0	0	0	0	0	0	0	0	0
Ethanol	0	0	0	0	0	0	0	0	0	0	0	0	0	0
Isopropanol	0	0	0	0	0	0	0	0	0	0	0	0	0	0
N-Propanol	6.4894	0	0	0	0	0	0	0	0	0	0	0	0	0
Isobutanol	0	0	0	0	0	0	0	0	0	0	0	0	0	0
N-Butanol	2817.3601	2.8194	0	0	0	0	0	0	0	0	0	0	0	0
1-Pentanol	1.4179	1416.5964	0	0	0	0	0	0	0	0	0	0	0	0

Table B.1. (contd)

Stream No.	720	721	722	725	726	727	728	729	730	731	732	733	734	736
Temp F	1000	1000	1000	999.9989	60	101.6421	90.9799	1800	1800	715.2508	715.2508	1060.6727	715.2508	715.2508
Pres psia	1265	1265	1265	1265	14.696	18	16	16	16	450	450	15	450	450
Enth MMBtu/h	-857.86	-380.13	-879.76	-2117.8	-0.87989	1.2289	-28.518	-151.51	-151.51	-2168.6	-265.68	-203.17	-30.888	-1872
Vapor mass fraction	1	1	1	1	1	1	1	1	1	1	1	1	1	1
Total lb/h	159635.016	70736.875	163709.578	394081.469	209601.422	209601.422	223852.313	223852	223852	394081.469	48280	223852	5613	340188.469
Flowrates in lb/h														
Oxygen	0	0	0	0	48819.2305	48819.2305	48819.2305	5906.4253	5906.4253	0	0	5906.4253	0	0
Nitrogen	0	0	0	0	160782.188	160782.188	161309.594	161305.219	161305.219	0	0	161305.219	0	0
Argon	0	0	0	0	0	0	0	0	0	0	0	0	0	0
Carbon	0	0	0	0	0	0	0	0	0	0	0	0	0	0
Hydrogen	0	0	0	0	0	0	103.2577	0.0007	0.0007	0	0	0.0007	0	0
Carbon Monoxide	0	0	0	0	0	0	1466.1241	0.008	0.008	0	0	0.008	0	0
Carbon Dioxide	0	0	0	0	0	0	970.5528	32243.4609	32243.4609	0	0	32243.4609	0	0
Methane	0	0	0	0	0	0	9483.4082	0.0001	0.0001	0	0	0.0001	0	0
Acetylene	0	0	0	0	0	0	0.0018	0.0002	0.0002	0	0	0.0002	0	0
Ethylene	0	0	0	0	0	0	0.4492	0.0002	0.0002	0	0	0.0002	0	0
Ethane	0	0	0	0	0	0	335.4442	0.0002	0.0002	0	0	0.0002	0	0
Propane	0	0	0	0	0	0	0	0	0	0	0	0	0	0
Water	159635.016	70736.875	163709.578	394081.469	0	0	70.0458	24362.1992	24362.1992	394081.469	48280	24362.1992	5613	340188.469
Sulphur	0	0	0	0	0	0	0	0	0	0	0	0	0	0
Carbonyl Sulfide	0	0	0	0	0	0	0	0	0	0	0	0	0	0
Hydrogen Sulfide	0	0	0	0	0	0	0	0	0	0	0	0	0	0
Ammonia	0	0	0	0	0	0	8.4906	0.0001	0.0001	0	0	0.0001	0	0
Hydrogen Chloride	0	0	0	0	0	0	10.004	10.004	10.004	0	0	10.004	0	0
Silicon Dioxide	0	0	0	0	0	0	0	0	0	0	0	0	0	0
Calcium Oxide	0	0	0	0	0	0	0	0	0	0	0	0	0	0
Benzene	0	0	0	0	0	0	0	0	0	0	0	0	0	0
Naphthalene	0	0	0	0	0	0	0	0	0	0	0	0	0	0
Hybrid Poplar Ch	0	0	0	0	0	0	0	0	0	0	0	0	0	0
Sulfur Dioxide	0	0	0	0	0	0	0	0	0	0	0	0	0	0
Hydrogen Cyanide	0	0	0	0	0	0	0.1969	0.0002	0.0002	0	0	0.0002	0	0
Nitric Oxide	0	0	0	0	0	0	0	24.5478	24.5478	0	0	24.5478	0	0
Methanol	0	0	0	0	0	0	894.434	0.0002	0.0002	0	0	0.0002	0	0
Ethanol	0	0	0	0	0	0	341.8956	0.0003	0.0003	0	0	0.0003	0	0
Isopropanol	0	0	0	0	0	0	0	0	0	0	0	0	0	0
N-Propanol	0	0	0	0	0	0	29.488	0.0004	0.0004	0	0	0.0004	0	0
Isobutanol	0	0	0	0	0	0	0	0	0	0	0	0	0	0
N-Butanol	0	0	0	0	0	0	6.5606	0.0005	0.0005	0	0	0.0005	0	0
1-Pentanol	0	0	0	0	0	0	3.1506	0.0005	0.0005	0	0	0.0005	0	0

Table B.1. (contd)

Stream No.	737	738	739	741	742	743	744	745	746	751	755	756	761	762
Temp F	456.3709	720	716.1438	259.3462	259.3462	259.3462	259.3462	259.3462	259.3462	115.5419	271.0406	289.0633	115.5419	115.5925
Pres psia	450	450	450	35	35	35	35	35	35	1.5	14	15	1.5	15
Enth MMBtu/h	-447.85	-434.1	-2306.1	-2398.9	-418.54	-851.42	-162.51	-955.04	-11.448	-984.61	-253.14	-252.06	-1132.5	-1132.5
Vapor mass fraction	0.98969	1	1	0.97884	0.97884	0.97884	0.97884	0.97884	0.97884	0.86212	1	1	0	0
Total lb/h	78924.0547	78924.0547	419112.531	419112.531	73122	148748	28391	166851.531	2000	166851.531	223852	223852	166851.531	166851.531
Flowrates in lb/h														
Oxygen	0	0	0	0	0	0	0	0	0	0	5906.4253	5906.4253	0	0
Nitrogen	0	0	0	0	0	0	0	0	0	0	161305.219	161305.219	0	0
Argon	0	0	0	0	0	0	0	0	0	0	0	0	0	0
Carbon	0	0	0	0	0	0	0	0	0	0	0	0	0	0
Hydrogen	0	0	0	0	0	0	0	0	0	0	0.0007	0.0007	0	0
Carbon Monoxide	0	0	0	0	0	0	0	0	0	0	0.008	0.008	0	0
Carbon Dioxide	0	0	0	0	0	0	0	0	0	0	32243.4609	32243.4609	0	0
Methane	0	0	0	0	0	0	0	0	0	0	0.0001	0.0001	0	0
Acetylene	0	0	0	0	0	0	0	0	0	0	0.0002	0.0002	0	0
Ethylene	0	0	0	0	0	0	0	0	0	0	0.0002	0.0002	0	0
Ethane	0	0	0	0	0	0	0	0	0	0	0.0002	0.0002	0	0
Propane	0	0	0	0	0	0	0	0	0	0	0	0	0	0
Water	78924.0547	78924.0547	419112.531	419112.531	73122	148748	28391	166851.531	2000	166851.531	24362.1992	24362.1992	166851.531	166851.531
Sulphur	0	0	0	0	0	0	0	0	0	0	0	0	0	0
Carbonyl Sulfide	0	0	0	0	0	0	0	0	0	0	0	0	0	0
Hydrogen Sulfide	0	0	0	0	0	0	0	0	0	0	0	0	0	0
Ammonia	0	0	0	0	0	0	0	0	0	0	0.0001	0.0001	0	0
HydrogenChloride	0	0	0	0	0	0	0	0	0	0	10.004	10.004	0	0
Silicon Dioxide	0	0	0	0	0	0	0	0	0	0	0	0	0	0
Calcium Oxide	0	0	0	0	0	0	0	0	0	0	0	0	0	0
Benzene	0	0	0	0	0	0	0	0	0	0	0	0	0	0
Naphthalene	0	0	0	0	0	0	0	0	0	0	0	0	0	0
Hybrid Poplar Ch	0	0	0	0	0	0	0	0	0	0	0	0	0	0
Sulfur Dioxide	0	0	0	0	0	0	0	0	0	0	0	0	0	0
Hydrogen Cyanide	0	0	0	0	0	0	0	0	0	0	0.0002	0.0002	0	0
Nitric Oxide	0	0	0	0	0	0	0	0	0	0	24.5478	24.5478	0	0
Methanol	0	0	0	0	0	0	0	0	0	0	0.0002	0.0002	0	0
Ethanol	0	0	0	0	0	0	0	0	0	0	0.0003	0.0003	0	0
Isopropanol	0	0	0	0	0	0	0	0	0	0	0	0	0	0
N-Propanol	0	0	0	0	0	0	0	0	0	0	0.0004	0.0004	0	0
Isobutanol	0	0	0	0	0	0	0	0	0	0	0	0	0	0
N-Butanol	0	0	0	0	0	0	0	0	0	0	0.0005	0.0005	0	0
1-Pentanol	0	0	0	0	0	0	0	0	0	0	0.0005	0.0005	0	0

Table B.1. (contd)

Stream No.	770	771	772	773	774	775	777	779	781	782	783	784	791	792
Temp F	60	179.5723	259.3442	259.3442	456.36	72.1549	199.9004	174.5574	176.2099	176.2099	179.3656	176.2099	575.2682	575.2682
Pres psia	60	28	35	35	450	60	19.7	15	450	450	1280	450	1280	1280
Enth MMBtu/h	-612.74	-239.83	-188.57	-988.05	-36.098	-611.65	-2064.2	-3208.1	-3207.3	-2676.4	-2675.2	-530.88	-40.523	-711.23
Vapor mass fraction	0	0	0	0	0	0	0	0	0	0	0	0	1	1
Total lb/h	89545	35672.6719	28388	148748	5613	89545	307966.531	476818.063	476818.063	397894.063	397894.063	78924	7121.9355	125000
Flowrates in lb/h														
Oxygen	0	0	0	0	0	0	0	0	0	0	0	0	0	0
Nitrogen	0	0	0	0	0	0	0	0	0	0	0	0	0	0
Argon	0	0	0	0	0	0	0	0	0	0	0	0	0	0
Carbon	0	0	0	0	0	0	0	0	0	0	0	0	0	0
Hydrogen	0	0	0	0	0	0	0	0	0	0	0	0	0	0
Carbon Monoxide	0	0	0	0	0	0	0	0	0	0	0	0	0	0
Carbon Dioxide	0	0	0	0	0	0	0	0	0	0	0	0	0	0
Methane	0	0	0	0	0	0	0	0	0	0	0	0	0	0
Acetylene	0	0	0	0	0	0	0	0	0	0	0	0	0	0
Ethylene	0	0	0	0	0	0	0	0	0	0	0	0	0	0
Ethane	0	0	0	0	0	0	0	0	0	0	0	0	0	0
Propane	0	0	0	0	0	0	0	0	0	0	0	0	0	0
Water	89545	35672.6719	28388	148748	5613	89545	307966.531	476818.063	476818.063	397894.063	397894.063	78924	7121.9355	125000
Sulphur	0	0	0	0	0	0	0	0	0	0	0	0	0	0
Carbonyl Sulfide	0	0	0	0	0	0	0	0	0	0	0	0	0	0
Hydrogen Sulfide	0	0	0	0	0	0	0	0	0	0	0	0	0	0
Ammonia	0	0	0	0	0	0	0	0	0	0	0	0	0	0
HydrogenChloride	0	0	0	0	0	0	0	0	0	0	0	0	0	0
Silicon Dioxide	0	0	0	0	0	0	0	0	0	0	0	0	0	0
Calcium Oxide	0	0	0	0	0	0	0	0	0	0	0	0	0	0
Benzene	0	0	0	0	0	0	0	0	0	0	0	0	0	0
Naphthalene	0	0	0	0	0	0	0	0	0	0	0	0	0	0
Hybrid Poplar Ch	0	0	0	0	0	0	0	0	0	0	0	0	0	0
Sulfur Dioxide	0	0	0	0	0	0	0	0	0	0	0	0	0	0
Hydrogen Cyanide	0	0	0	0	0	0	0	0	0	0	0	0	0	0
Nitric Oxide	0	0	0	0	0	0	0	0	0	0	0	0	0	0
Methanol	0	0	0	0	0	0	0	0	0	0	0	0	0	0
Ethanol	0	0	0	0	0	0	0	0	0	0	0	0	0	0
Isopropanol	0	0	0	0	0	0	0	0	0	0	0	0	0	0
N-Propanol	0	0	0	0	0	0	0	0	0	0	0	0	0	0
Isobutanol	0	0	0	0	0	0	0	0	0	0	0	0	0	0
N-Butanol	0	0	0	0	0	0	0	0	0	0	0	0	0	0
1-Pentanol	0	0	0	0	0	0	0	0	0	0	0	0	0	0

Table B.1. (contd)

Stream No.	794	795	796	797	798	1602	1603	1604	1605	1701	1702	1703	1741	1742
Temp F	1000	575.2682	1000	179.5723	720	41.2403	41.2403	41.2403	41.2403	140	140	140	277.9421	181.6632
Pres psia	1265	1280	1265	28	450	16	16	16	16	15	15	15	28	54
Enth MMBtu/h	-857.86	-572.22	-380.13	-239.83	-434.1	-55.088	-1.2119	-29.747	-24.128	-58607	-586.06	-58020	0	-70.851
Vapor mass fraction	1	1	1	0	1	0.97147	0.97147	0.97147	0.97147	0	0	0	0	0
Total lb/h	159635.016	100568.242	70736.875	35672.6719	78924.0547	26390.5586	580.5922	14250.9014	11559.0654	8690904	86908.8203	8603973	0	10541.7666
Flowrates in lb/h														
Oxygen	0	0	0	0	0	0	0	0	0	0	0	0	0	0
Nitrogen	0	0	0	0	0	976.6617	21.4866	527.3973	427.7778	0.2494	0.0025	0.2469	0	0
Argon	0	0	0	0	0	0	0	0	0	0	0	0	0	0
Carbon	0	0	0	0	0	0	0	0	0	0	0	0	0	0
Hydrogen	0	0	0	0	0	191.2179	4.2068	103.2577	83.7534	3.0927	0.0309	3.0617	0	0
Carbon Monoxide	0	0	0	0	0	2715.0447	59.731	1466.1241	1189.1895	45.3898	0.4539	44.936	0	0
Carbon Dioxide	0	0	0	0	0	1797.3199	39.541	970.5528	787.2261	30858.6641	308.5646	30547.8984	0	0
Methane	0	0	0	0	0	17561.8672	386.3611	9483.4082	7692.0977	9.7011	0.097	9.6041	0	0
Acetylene	0	0	0	0	0	0.0034	0.0001	0.0018	0.0015	0.3578	0.0036	0.3542	0	0
Ethylene	0	0	0	0	0	0.8318	0.0183	0.4492	0.3643	9.3461	0.0935	9.2526	0	0
Ethane	0	0	0	0	0	621.1929	13.6662	335.4442	272.0825	0.0417	0.0004	0.0413	0	0
Propane	0	0	0	0	0	0	0	0	0	0	0	0	0	0
Water	159635.016	100568.242	70736.875	35672.6719	78924.0547	129.7145	2.8537	70.0458	56.815	8644681	86446.6406	8558217	0	10541.7666
Sulphur	0	0	0	0	0	0	0	0	0	0	0	0	0	0
Carbonyl Sulfide	0	0	0	0	0	0	0	0	0	0	0	0	0	0
Hydrogen Sulfide	0	0	0	0	0	0	0	0	0	45.1209	0.4512	44.668	0	0
Ammonia	0	0	0	0	0	15.7234	0.3459	8.4906	6.8868	15250.8525	152.4876	15096.2705	0	0
HydrogenChloride	0	0	0	0	0	18.5259	0.4076	10.004	8.1143	0.2041	0.002	0.2021	0	0
Silicon Dioxide	0	0	0	0	0	0	0	0	0	0	0	0	0	0
Calcium Oxide	0	0	0	0	0	0	0	0	0	0	0	0	0	0
Benzene	0	0	0	0	0	0	0	0	0	0.3661	0.0037	0.3624	0	0
Naphthalene	0	0	0	0	0	0	0	0	0	0.1413	0.0014	0.1399	0	0
Hybrid Poplar Ch	0	0	0	0	0	0	0	0	0	0	0	0	0	0
Sulfur Dioxide	0	0	0	0	0	0	0	0	0	0	0	0	0	0
Hydrogen Cyanide	0	0	0	0	0	0.3646	0.008	0.1969	0.1597	0	0	0	0	0
Nitric Oxide	0	0	0	0	0	0	0	0	0	0	0	0	0	0
Methanol	0	0	0	0	0	1656.3593	36.4399	894.434	725.4853	0	0	0	0	0
Ethanol	0	0	0	0	0	633.14	13.9291	341.8956	277.3153	0	0	0	0	0
Isopropanol	0	0	0	0	0	0	0	0	0	0	0	0	0	0
N-Propanol	0	0	0	0	0	54.6074	1.2014	29.488	23.918	0	0	0	0	0
Isobutanol	0	0	0	0	0	0	0	0	0	0	0	0	0	0
N-Butanol	0	0	0	0	0	12.1492	0.2673	6.5606	5.3214	0	0	0	0	0
1-Pentanol	0	0	0	0	0	5.8345	0.1284	3.1506	2.5555	0	0	0	0	0

Table B.1. (contd)

Stream No.	1743	1744	1745	1746	1747	1748	1749	1750	1751	1830	1831	1834	1835	1840
Temp F	181.6632	195.5736	188.2532	209.1053	192.9911	231.225	196.6364	179.5723	110	90	110	90	110	90
Pres psia	28	109.5	28	220	28	465	28	28	417.5	60	60	60	60	65
Enth MMBtu/h	-70.851	-63.596	-134.45	-39.358	-173.8	-18.155	-191.96	-239.83	-247.66	-83888	-83641	-569.06	-567.4	-931.27
Vapor mass fraction	0	0	0	0	0	0	0	0	0	0	0	0	0	0
Total lb/h	10541.7666	9482.0117	20023.7773	5880.0854	25903.8633	2721.4614	28625.3242	35672.6719	36458.7539	12313236	12313236	83529.2891	83529.2891	136694
Flowrates in lb/h														
Oxygen	0	0	0	0	0	0	0	0	0	0	0	0	0	0
Nitrogen	0	0	0	0	0	0	0	0	0	0	0	0	0	0
Argon	0	0	0	0	0	0	0	0	0	0	0	0	0	0
Carbon	0	0	0	0	0	0	0	0	0	0	0	0	0	0
Hydrogen	0	0	0	0	0	0	0	0	0	0	0	0	0	0
Carbon Monoxide	0	0	0	0	0	0	0	0	0	0	0	0	0	0
Carbon Dioxide	0	0	0	0	0	0	0	0	0	0	0	0	0	0
Methane	0	0	0	0	0	0	0	0	0	0	0	0	0	0
Acetylene	0	0	0	0	0	0	0	0	0	0	0	0	0	0
Ethylene	0	0	0	0	0	0	0	0	0	0	0	0	0	0
Ethane	0	0	0	0	0	0	0	0	0	0	0	0	0	0
Propane	0	0	0	0	0	0	0	0	0	0	0	0	0	0
Water	10541.7666	9482.0117	20023.7773	5880.0854	25903.8633	2721.4614	28625.3242	35672.6719	36458.7539	12313236	12313236	83529.2891	83529.2891	136694
Sulphur	0	0	0	0	0	0	0	0	0	0	0	0	0	0
Carbonyl Sulfide	0	0	0	0	0	0	0	0	0	0	0	0	0	0
Hydrogen Sulfide	0	0	0	0	0	0	0	0	0	0	0	0	0	0
Ammonia	0	0	0	0	0	0	0	0	0	0	0	0	0	0
HydrogenChloride	0	0	0	0	0	0	0	0	0	0	0	0	0	0
Silicon Dioxide	0	0	0	0	0	0	0	0	0	0	0	0	0	0
Calcium Oxide	0	0	0	0	0	0	0	0	0	0	0	0	0	0
Benzene	0	0	0	0	0	0	0	0	0	0	0	0	0	0
Naphthalene	0	0	0	0	0	0	0	0	0	0	0	0	0	0
Hybrid Poplar Ch	0	0	0	0	0	0	0	0	0	0	0	0	0	0
Sulfur Dioxide	0	0	0	0	0	0	0	0	0	0	0	0	0	0
Hydrogen Cyanide	0	0	0	0	0	0	0	0	0	0	0	0	0	0
Nitric Oxide	0	0	0	0	0	0	0	0	0	0	0	0	0	0
Methanol	0	0	0	0	0	0	0	0	0	0	0	0	0	0
Ethanol	0	0	0	0	0	0	0	0	0	0	0	0	0	0
Isopropanol	0	0	0	0	0	0	0	0	0	0	0	0	0	0
N-Propanol	0	0	0	0	0	0	0	0	0	0	0	0	0	0
Isobutanol	0	0	0	0	0	0	0	0	0	0	0	0	0	0
N-Butanol	0	0	0	0	0	0	0	0	0	0	0	0	0	0
1-Pentanol	0	0	0	0	0	0	0	0	0	0	0	0	0	0

Table B.1. (contd)

Stream No.	1841	1842	1843	1850	1851	1861	1862	1871	1872	1910	1931	1932	1935	1936
Temp F	110	90	110	90	110	90	110	90	110	259.3482	179	575.2682	179	400
Pres psia	65	65	65	65	60	60	60	65	65	35	1280	1280	1280	1280
Enth MMBtu/h	-928.54	-1919.8	-1914.2	-13479	-13439	-155.23	-154.77	-50368	-50220	-417.08	-47.886	-40.523	-840.46	-811.81
Vapor mass fraction	0	0	0	0	0	0	0	0	0	1	0	1	0	0
Total lb/h	136694	281794	281794	1978409.88	1978409.88	22784.5566	22784.5566	7393089.5	7393089.5	73120.0938	7121.9355	7121.9355	125000	125000
Flowrates in lb/h														
Oxygen	0	0	0	0	0	0	0	0	0	0	0	0	0	0
Nitrogen	0	0	0	0	0	0	0	0	0	0	0	0	0	0
Argon	0	0	0	0	0	0	0	0	0	0	0	0	0	0
Carbon	0	0	0	0	0	0	0	0	0	0	0	0	0	0
Hydrogen	0	0	0	0	0	0	0	0	0	0	0	0	0	0
Carbon Monoxide	0	0	0	0	0	0	0	0	0	0	0	0	0	0
Carbon Dioxide	0	0	0	0	0	0	0	0	0	0	0	0	0	0
Methane	0	0	0	0	0	0	0	0	0	0	0	0	0	0
Acetylene	0	0	0	0	0	0	0	0	0	0	0	0	0	0
Ethylene	0	0	0	0	0	0	0	0	0	0	0	0	0	0
Ethane	0	0	0	0	0	0	0	0	0	0	0	0	0	0
Propane	0	0	0	0	0	0	0	0	0	0	0	0	0	0
Water	136694	281794	281794	1978409.88	1978409.88	22784.5566	22784.5566	7393089.5	7393089.5	73120.0938	7121.9355	7121.9355	125000	125000
Sulphur	0	0	0	0	0	0	0	0	0	0	0	0	0	0
Carbonyl Sulfide	0	0	0	0	0	0	0	0	0	0	0	0	0	0
Hydrogen Sulfide	0	0	0	0	0	0	0	0	0	0	0	0	0	0
Ammonia	0	0	0	0	0	0	0	0	0	0	0	0	0	0
HydrogenChloride	0	0	0	0	0	0	0	0	0	0	0	0	0	0
Silicon Dioxide	0	0	0	0	0	0	0	0	0	0	0	0	0	0
Calcium Oxide	0	0	0	0	0	0	0	0	0	0	0	0	0	0
Benzene	0	0	0	0	0	0	0	0	0	0	0	0	0	0
Naphthalene	0	0	0	0	0	0	0	0	0	0	0	0	0	0
Hybrid Poplar Ch	0	0	0	0	0	0	0	0	0	0	0	0	0	0
Sulfur Dioxide	0	0	0	0	0	0	0	0	0	0	0	0	0	0
Hydrogen Cyanide	0	0	0	0	0	0	0	0	0	0	0	0	0	0
Nitric Oxide	0	0	0	0	0	0	0	0	0	0	0	0	0	0
Methanol	0	0	0	0	0	0	0	0	0	0	0	0	0	0
Ethanol	0	0	0	0	0	0	0	0	0	0	0	0	0	0
Isopropanol	0	0	0	0	0	0	0	0	0	0	0	0	0	0
N-Propanol	0	0	0	0	0	0	0	0	0	0	0	0	0	0
Isobutanol	0	0	0	0	0	0	0	0	0	0	0	0	0	0
N-Butanol	0	0	0	0	0	0	0	0	0	0	0	0	0	0
1-Pentanol	0	0	0	0	0	0	0	0	0	0	0	0	0	0

Table B.1. (contd)

Stream No.	1938	1940	1943	1944	1945	1946	1948	1949	1950	1951	1952	1953	1954	1955
Temp F	575.2682	715.0002	573.7587	1000	456.3709	720	573.7587	1000	179	575.2682	176	456.3709	456.3709	715.0002
Pres psia	1280	450	1265	1265	450	450	1265	1265	1280	1280	450	450	450	1265
Enth MMBtu/h	-711.23	-265.69	-908.2	-857.86	-447.85	-434.1	-402.44	-380.13	-676.19	-572.22	-530.9	-447.85	-447.85	-31.172
Vapor mass fraction	1	1	1	1	0.98969	1	1	1	0	1	0	0.98969	0.98969	1
Total lb/h	125000	48280.1992	159635.016	159635.016	78924.0547	78924.0547	70736.875	70736.875	100568.242	100568.242	78924.0547	78924.0547	78924.0547	5612.6958
Flowrates in lb/h														
Oxygen	0	0	0	0	0	0	0	0	0	0	0	0	0	0
Nitrogen	0	0	0	0	0	0	0	0	0	0	0	0	0	0
Argon	0	0	0	0	0	0	0	0	0	0	0	0	0	0
Carbon	0	0	0	0	0	0	0	0	0	0	0	0	0	0
Hydrogen	0	0	0	0	0	0	0	0	0	0	0	0	0	0
Carbon Monoxide	0	0	0	0	0	0	0	0	0	0	0	0	0	0
Carbon Dioxide	0	0	0	0	0	0	0	0	0	0	0	0	0	0
Methane	0	0	0	0	0	0	0	0	0	0	0	0	0	0
Acetylene	0	0	0	0	0	0	0	0	0	0	0	0	0	0
Ethylene	0	0	0	0	0	0	0	0	0	0	0	0	0	0
Ethane	0	0	0	0	0	0	0	0	0	0	0	0	0	0
Propane	0	0	0	0	0	0	0	0	0	0	0	0	0	0
Water	125000	48280.1992	159635.016	159635.016	78924.0547	78924.0547	70736.875	70736.875	100568.242	100568.242	78924.0547	78924.0547	78924.0547	5612.6958
Sulphur	0	0	0	0	0	0	0	0	0	0	0	0	0	0
Carbonyl Sulfide	0	0	0	0	0	0	0	0	0	0	0	0	0	0
Hydrogen Sulfide	0	0	0	0	0	0	0	0	0	0	0	0	0	0
Ammonia	0	0	0	0	0	0	0	0	0	0	0	0	0	0
HydrogenChloride	0	0	0	0	0	0	0	0	0	0	0	0	0	0
Silicon Dioxide	0	0	0	0	0	0	0	0	0	0	0	0	0	0
Calcium Oxide	0	0	0	0	0	0	0	0	0	0	0	0	0	0
Benzene	0	0	0	0	0	0	0	0	0	0	0	0	0	0
Naphthalene	0	0	0	0	0	0	0	0	0	0	0	0	0	0
Hybrid Poplar Ch	0	0	0	0	0	0	0	0	0	0	0	0	0	0
Sulfur Dioxide	0	0	0	0	0	0	0	0	0	0	0	0	0	0
Hydrogen Cyanide	0	0	0	0	0	0	0	0	0	0	0	0	0	0
Nitric Oxide	0	0	0	0	0	0	0	0	0	0	0	0	0	0
Methanol	0	0	0	0	0	0	0	0	0	0	0	0	0	0
Ethanol	0	0	0	0	0	0	0	0	0	0	0	0	0	0
Isopropanol	0	0	0	0	0	0	0	0	0	0	0	0	0	0
N-Propanol	0	0	0	0	0	0	0	0	0	0	0	0	0	0
Isobutanol	0	0	0	0	0	0	0	0	0	0	0	0	0	0
N-Butanol	0	0	0	0	0	0	0	0	0	0	0	0	0	0
1-Pentanol	0	0	0	0	0	0	0	0	0	0	0	0	0	0

Table B.1. (contd)

Stream No.	1956	1961	1962	1971	1972	1973	1974	1975
Temp F	573.7568	259.3482	259.3462	179	465	574.2614	574.2614	574.2614
Pres psia	1265	35	35	1280	1275	1270	1270	1270
Enth MMBtu/h	-35.286	-161.95	-188.59	-1110.7	-1060.8	-940.77	-9.3534	-931.42
Vapor mass fraction	1.00E-08	1	0	0	0	0.99099	0	1
Total lb/h	5612.6958	28392.0762	28392.0762	165197.547	165197.547	165197.547	1487.9614	163709.578
Flowrates in lb/h								
Oxygen	0	0	0	0	0	0	0	0
Nitrogen	0	0	0	0	0	0	0	0
Argon	0	0	0	0	0	0	0	0
Carbon	0	0	0	0	0	0	0	0
Hydrogen	0	0	0	0	0	0	0	0
Carbon Monoxide	0	0	0	0	0	0	0	0
Carbon Dioxide	0	0	0	0	0	0	0	0
Methane	0	0	0	0	0	0	0	0
Acetylene	0	0	0	0	0	0	0	0
Ethylene	0	0	0	0	0	0	0	0
Ethane	0	0	0	0	0	0	0	0
Propane	0	0	0	0	0	0	0	0
Water	5612.6958	28392.0762	28392.0762	165197.547	165197.547	165197.547	1487.9614	163709.578
Sulphur	0	0	0	0	0	0	0	0
Carbonyl Sulfide	0	0	0	0	0	0	0	0
Hydrogen Sulfide	0	0	0	0	0	0	0	0
Ammonia	0	0	0	0	0	0	0	0
HydrogenChloride	0	0	0	0	0	0	0	0
Silicon Dioxide	0	0	0	0	0	0	0	0
Calcium Oxide	0	0	0	0	0	0	0	0
Benzene	0	0	0	0	0	0	0	0
Naphthalene	0	0	0	0	0	0	0	0
Hybrid Poplar Ch	0	0	0	0	0	0	0	0
Sulfur Dioxide	0	0	0	0	0	0	0	0
Hydrogen Cyanide	0	0	0	0	0	0	0	0
Nitric Oxide	0	0	0	0	0	0	0	0
Methanol	0	0	0	0	0	0	0	0
Ethanol	0	0	0	0	0	0	0	0
Isopropanol	0	0	0	0	0	0	0	0
N-Propanol	0	0	0	0	0	0	0	0
Isobutanol	0	0	0	0	0	0	0	0
N-Butanol	0	0	0	0	0	0	0	0
1-Pentanol	0	0	0	0	0	0	0	0

B.2 Oxygen Blown Directly Heated Gasifier Model

Figure B.8 shows the process flow diagram for the *Base Case* directly-heated gasifier system. Figures B.9 to B.15 show the flow sheets for each main area in the system. Table B.2 lists corresponding heat and material balances.

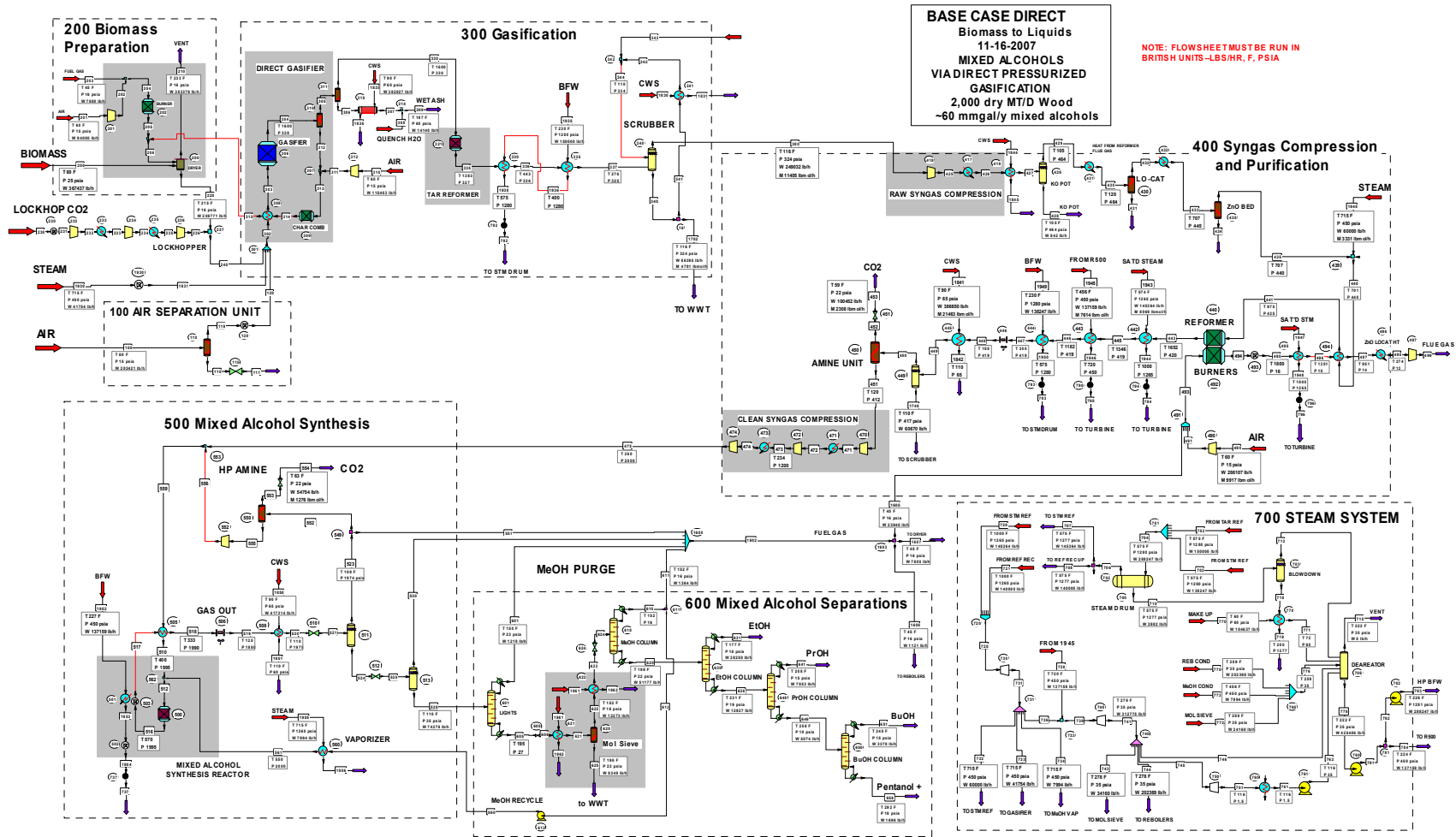

Figure B.8. Flow Sheet for Mixed Alcohol Production – Directly Heated Gasifier Base Case

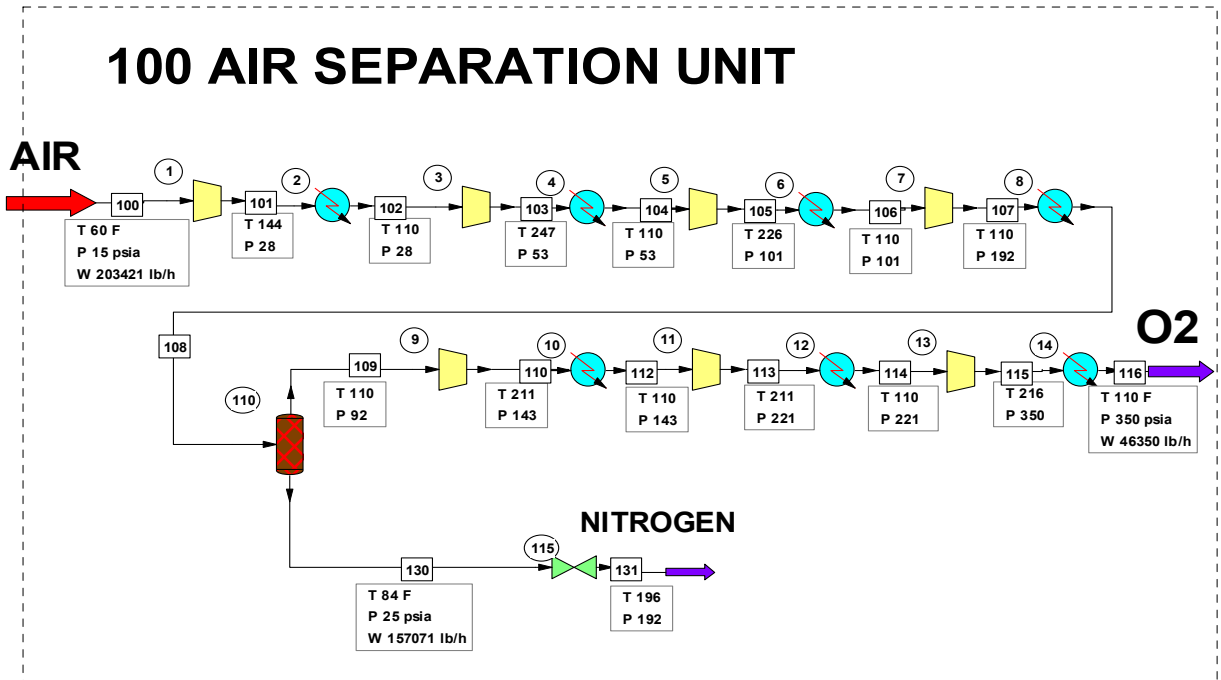

Figure B.9. Flow Sheet for Area 100 Air Separation Unit – Directly Heated Gasifier Base Case

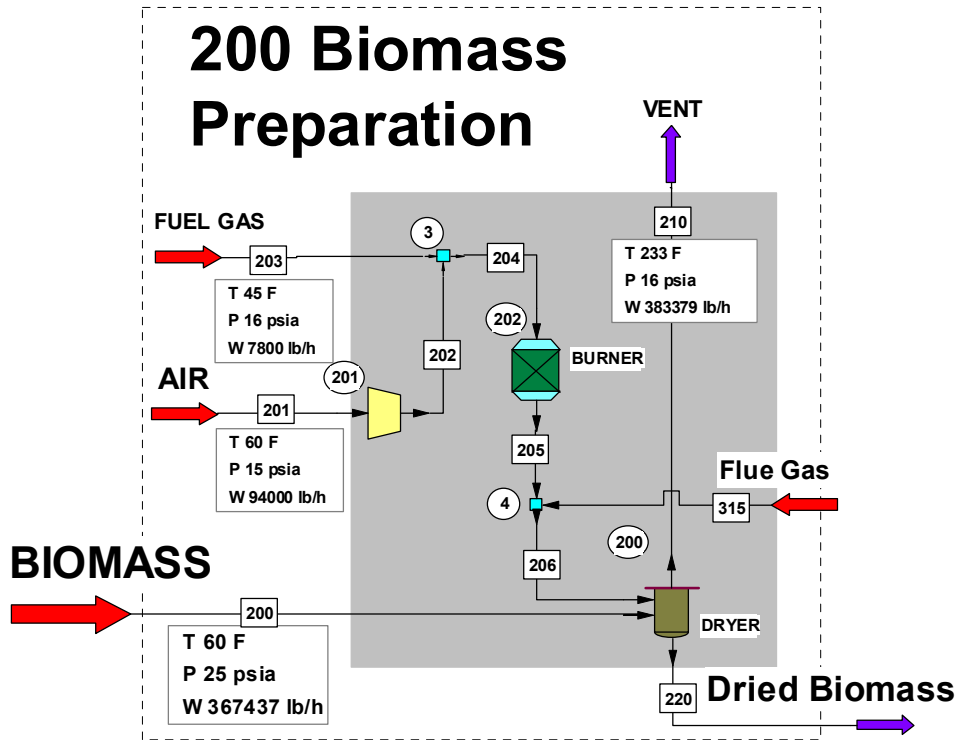

Figure B.10. Flow Sheet for Area 200 Biomass Preparation – Directly Heated Gasifier Base Case

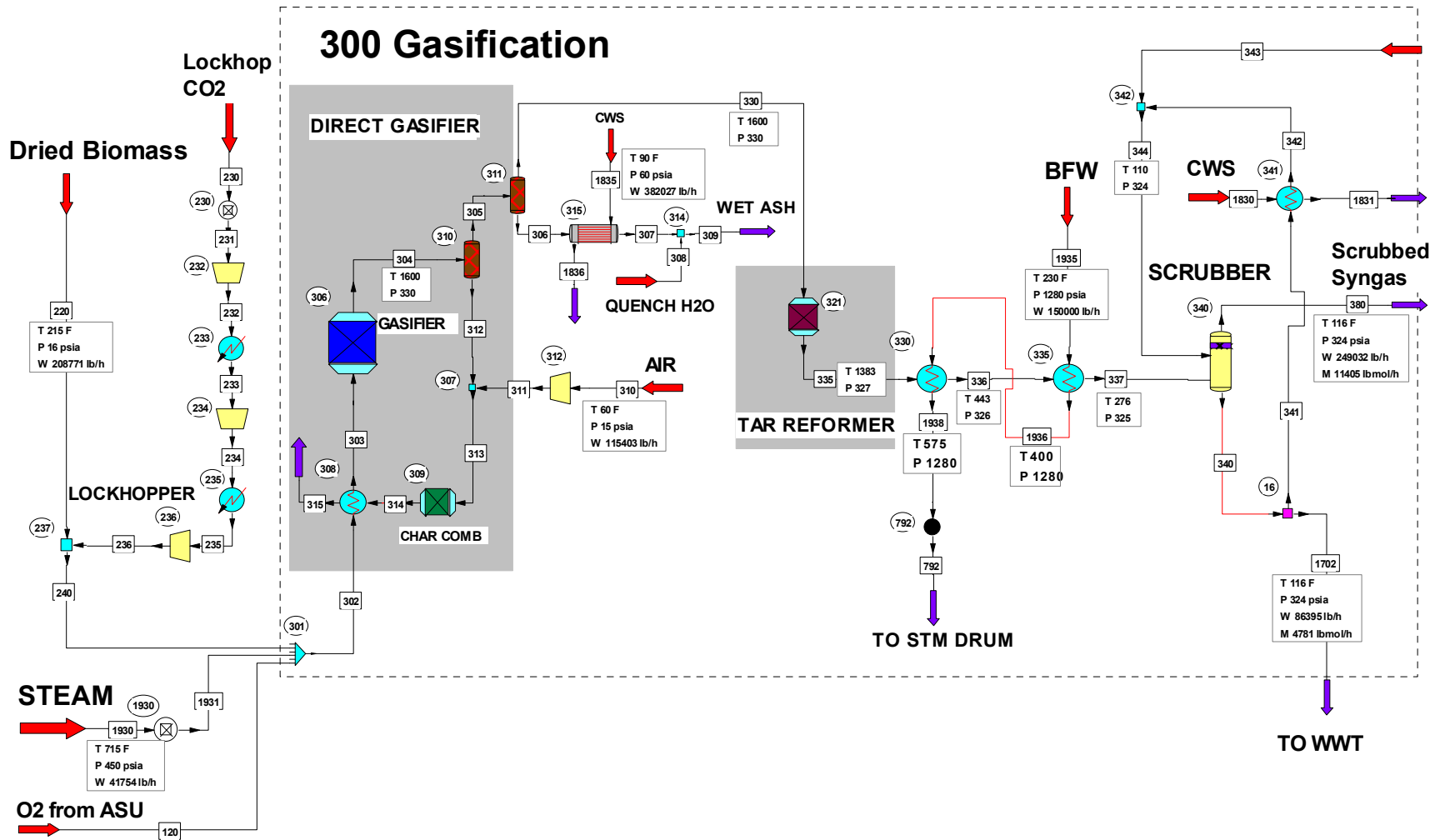

Figure B.11. Flow Sheet for Area 300 Gasification – Directly Heated Gasifier Base Case

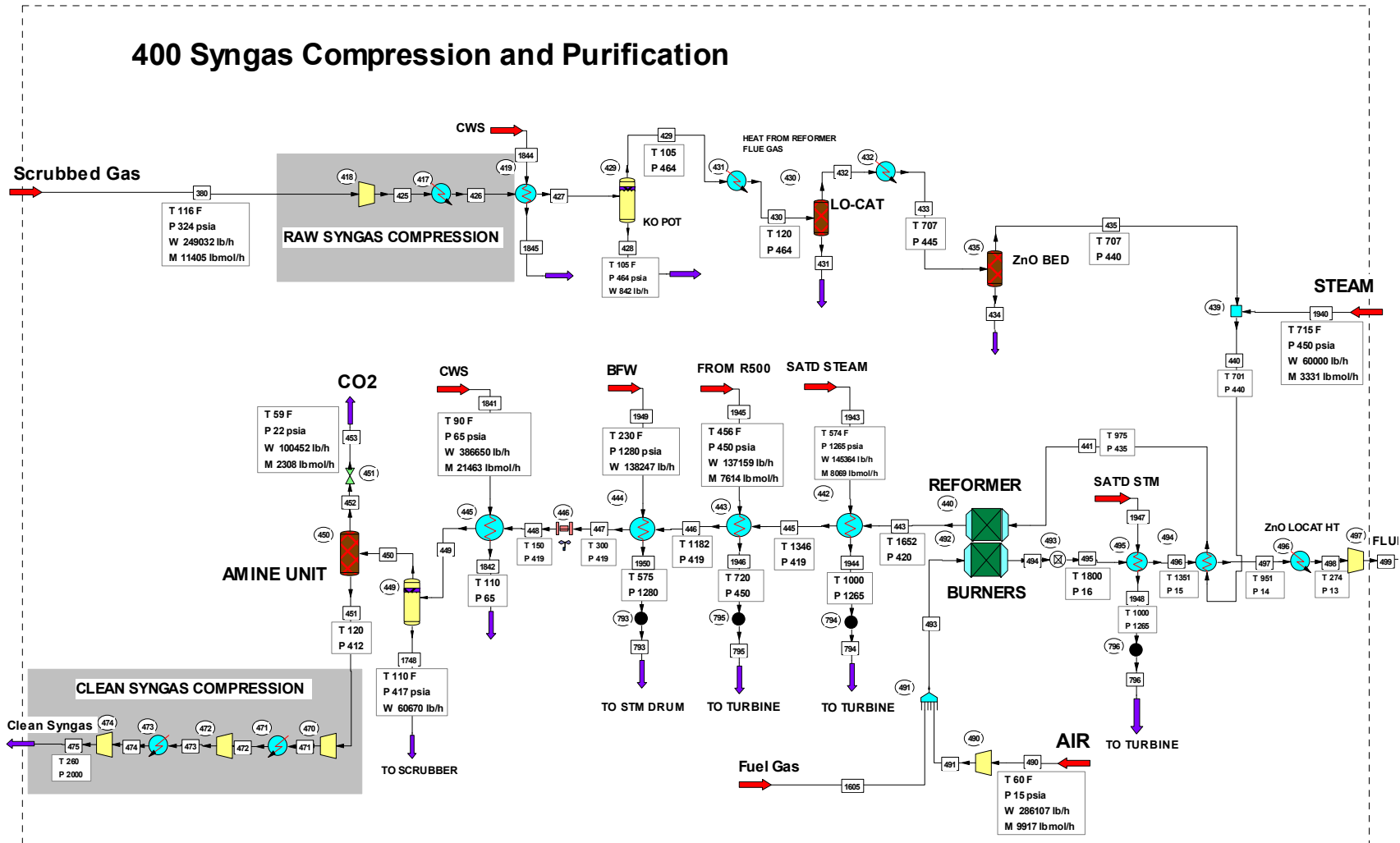

Figure B.12. Flow Sheet for Area 400 Syngas Compression and Purification – Directly Heated Gasifier Base Case

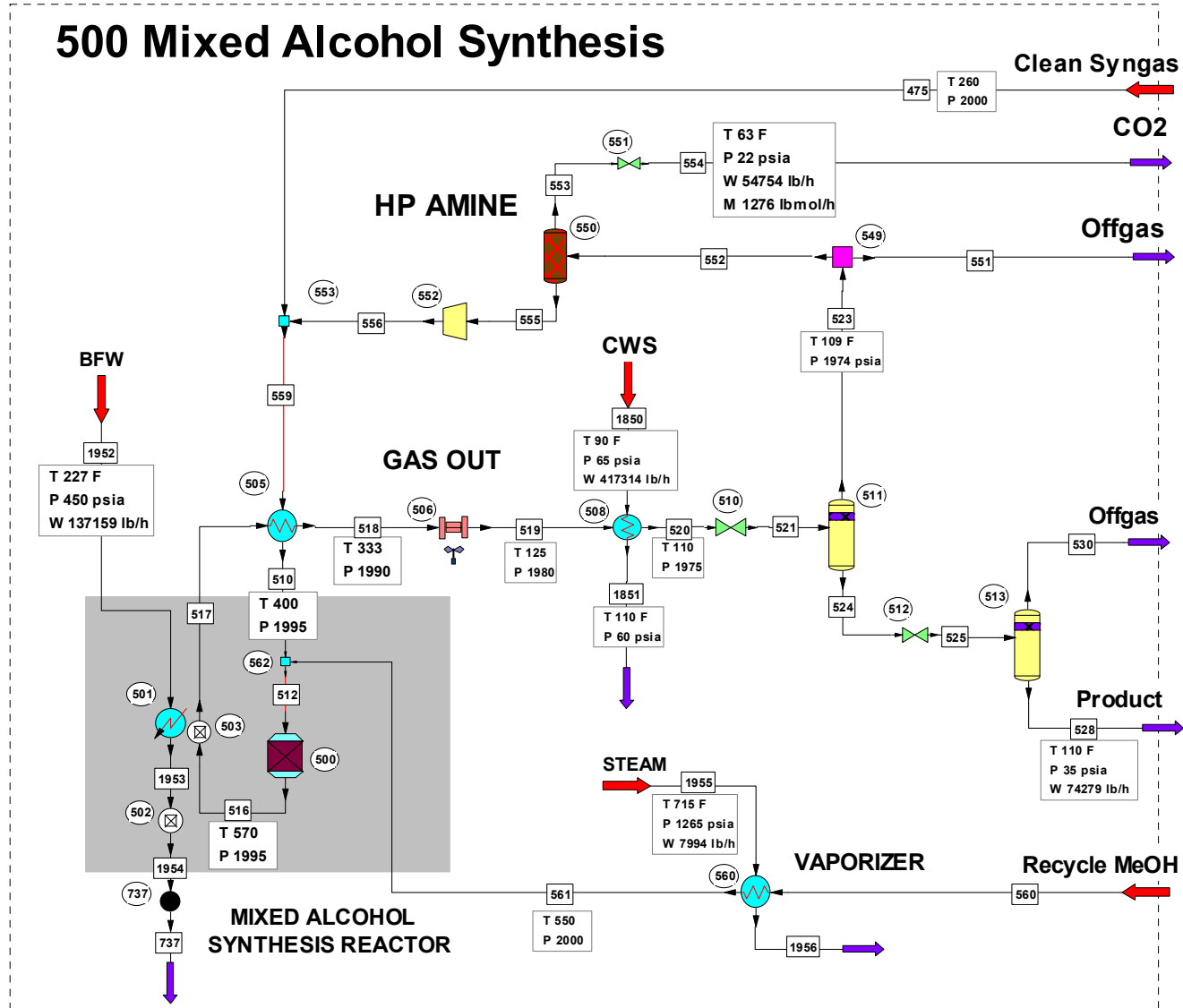

Figure B.13. Flow Sheet for Area 500 Mixed Alcohol Synthesis – Directly Heated Gasifier Base Case

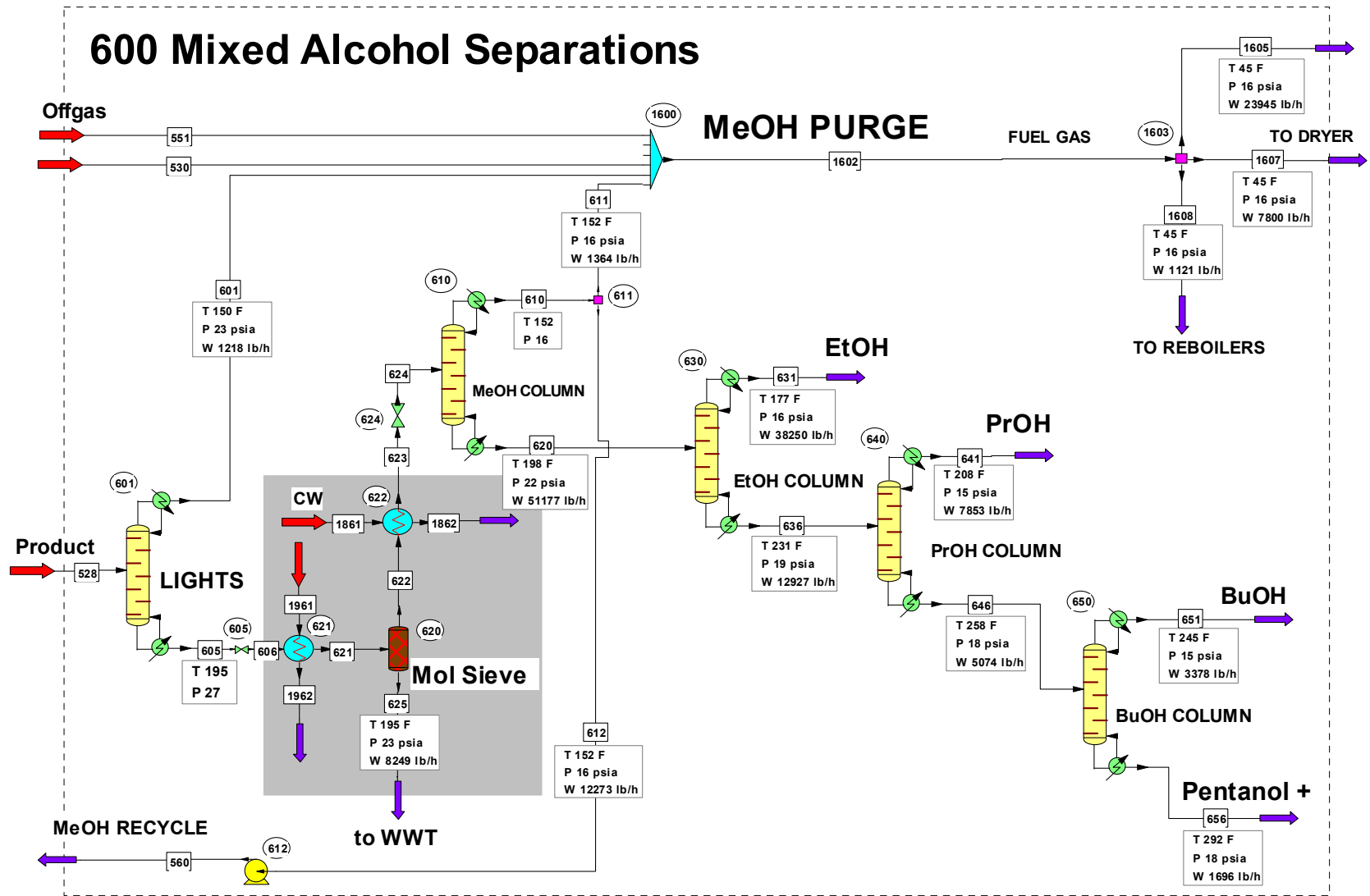

Figure B.14. Flow Sheet for Area 600 Mixed Alcohol Separation – Directly Heated Gasifier Base Case

B.31

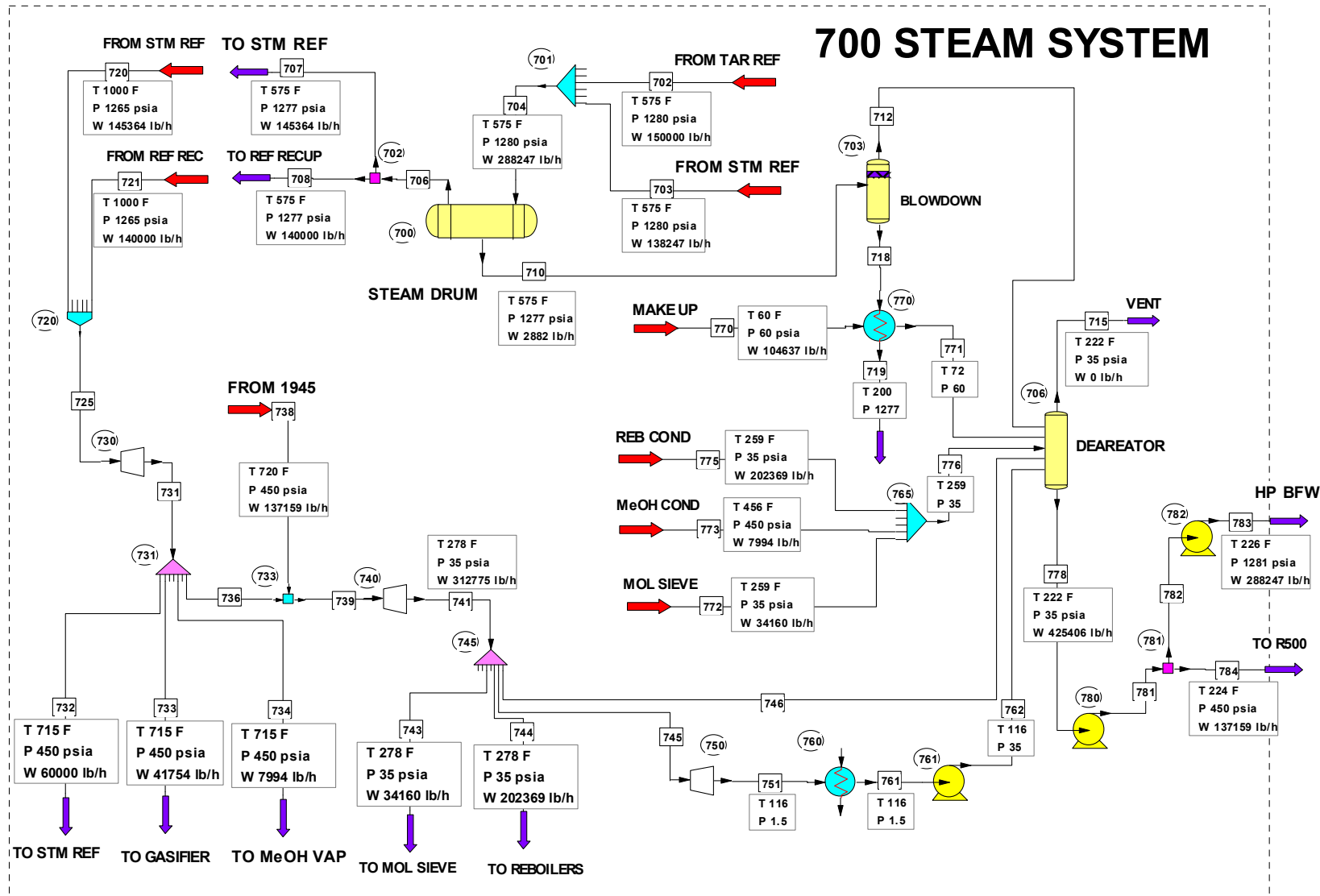

Figure B.15. Flow Sheet for Area 700 Steam System – Directly Heated Gasifier Base Case

Table B.2. Heat and Material Balances for the Base Case Indirectly Heated Gasifier

Stream No.	100	110	111	119	120	200	201	202	203	204	205	206	210	220
Temp F	60	60	41.973	60	60	60	60	91.4583	44.7055	81.4333	3343.777	3024.4728	232.8891	215
Pres psia	14.696	350	25	350	350	25	14.696	17	16	16	16	16	16	16
Enth MMBtu/h	-26.033	-28.406	-28.406	-0.29269	-0.29269	-1744.9	-0.39461	0.31979	-16.996	-16.676	-16.676	-48.51	-1147.6	-645.89
Vapor mass fraction	0.99137	0.97527	0.97805	1	1	0	1	1	0.97455	1	1	1	1	0
Total lb/h	203421	157070.594	157070.594	46350.4297	46350.418	367437.406	94000.0078	94000.0078	7800.002	101800.023	101799.828	224713.297	383379.438	208771.25
Flowrates in lb/h														
Oxygen	46153.1094	39.6902	39.6902	46113.4453	46113.4336	0	21894.0449	21894.0449	0	21894.0449	2775.2058	6316.5342	6316.5342	0
Nitrogen	150629.688	150547	150547	82.8464	82.8463	0	72106	72106	210.98	72317	72147.5469	160343.359	160343.359	0
Argon	2568.9688	2414.8308	2414.8308	154.1382	154.1381	0	0	0	36.6478	36.6478	36.6478	36.6478	36.6478	0
Carbon	0	0	0	0	0	0	0	0	0	0	0	0.0002	0.0002	0
Hydrogen	0	0	0	0	0	0	0	0	98.5847	98.5847	4.3963	14.864	14.864	0
Carbon Monoxide	0	0	0	0	0	0	0	0	1570.4126	1570.4126	187.3857	1167.8114	1167.8114	0
Carbon Dioxide	100.2928	100.2928	100.2928	0	0	0	0	0	1052.9977	1052.9977	15515.5254	36894.2344	36894.2344	0
Methane	0	0	0	0	0	0	0	0	3891.4175	3891.4175	0.0001	0.0001	0.0001	0
Acetylene	0	0	0	0	0	0	0	0	0	0	0	0	0	0
Ethylene	0	0	0	0	0	0	0	0	0.1079	0.1079	0.0001	0.0001	0.0001	0
Ethane	0	0	0	0	0	0	0	0	178.7961	178.7961	0.0001	0.0001	0.0001	0
Propane	0	0	0	0	0	0	0	0	0	0	0	0	0	0
Water	3968.927	3968.928	3968.9272	0	0	183718.703	0	0	31.0094	31.0094	10763.7422	18780.541	177446.688	25052.5488
Sulphur	0	0	0	0	0	0	0	0	0	0	0	0.0002	0.0002	0
Carbonyl Sulfide	0	0	0	0	0	0	0	0	0	0	0	0	0	0
Hydrogen Sulfide	0	0	0	0	0	0	0	0	0	0	0	0	0	0
Ammonia	0	0	0	0	0	0	0	0	3.639	3.639	0.0001	0.0001	0.0001	0
HydrogenChloride	0	0	0	0	0	0	0	0	0	0	0	0	0	0
Calcium Oxide	0	0	0	0	0	0	0	0	0	0	0	0	0	0
Benzene	0	0	0	0	0	0	0	0	0	0	0	0	0	0
Naphthalene	0	0	0	0	0	0	0	0	0	0	0	0	0	0
Hybrid Poplar Ch	0	0	0	0	0	183718.703	0	0	0	0	0	0	0	183718.703
Sulfur Dioxide	0	0	0	0	0	0	0	0	0	0	0	6.0849	6.0849	0
Hydrogen Cyanide	0	0	0	0	0	0	0	0	0.0633	0.0633	0.0001	0.0001	0.0001	0
Nitric Oxide	0	0	0	0	0	0	0	0	0	0	369.3846	1153.2338	1153.2338	0
Methanol	0	0	0	0	0	0	0	0	561.6821	561.6821	0.0001	0.0001	0.0001	0
Ethanol	0	0	0	0	0	0	0	0	145.2101	145.2101	0.0002	0.0002	0.0002	0
Isopropanol	0	0	0	0	0	0	0	0	0	0	0	0	0	0
N-Propanol	0	0	0	0	0	0	0	0	14.1388	14.1388	0.0002	0.0002	0.0002	0
Isobutanol	0	0	0	0	0	0	0	0	0	0	0	0	0	0
N-Butanol	0	0	0	0	0	0	0	0	2.965	2.965	0.0002	0.0002	0.0002	0
1-Pentanol	0	0	0	0	0	0	0	0	1.3495	1.3495	0.0002	0.0002	0.0002	0

Table B.2. (contd)

Stream No.	230	231	232	233	234	235	236	240	302	303	304	305	306	307
Temp F	70	70	276.024	140	263.2057	140	282.0417	214.7715	365.9011	433	1600	1600	1600	300
Pres psia	22	22	75	75	150	150	330	330	330	330	330	330	330	330
Enth MMBtu/h	-23.166	-23.166	-22.902	-23.085	-22.927	-23.096	-22.916	-668.8	-898.87	-857.4	-857.53	-865.88	-41.84	-49.483
Vapor mass fraction	1	1	1	1	1	1	1	0.19779	0.67758	1	0.98309	0.98301	0.0003125	0.0003125
Total lb/h	6023.0806	6023.0806	6023.0806	6023.0806	6023.0806	6023.0806	6023.0806	214794.344	302898.5	302898.5	302898.313	295388.375	4960.4048	4960.4048
Flowrates in lb/h														
Oxygen	0	0	0	0	0	0	0	0	46113.4336	46113.4336	307.1113	0	0	0
Nitrogen	0	0	0	0	0	0	0	0	82.8463	82.8463	120.38	82.8463	0	0
Argon	0	0	0	0	0	0	0	0	154.1381	154.1381	154.1381	154.1381	0	0
Carbon	0	0	0	0	0	0	0	0	0	0	6254.937	0	0	0
Hydrogen	0	0	0	0	0	0	0	0	0	0	4562.5776	3655.0735	0	0
Carbon Monoxide	0	0	0	0	0	0	0	0	0	0	49736.6641	49736.7148	0	0
Carbon Dioxide	6023.0806	6023.0806	6023.0806	6023.0806	6023.0806	6023.0806	6023.0806	6023.0806	6023.0806	6023.0806	135752.594	135752.672	0	0
Methane	0	0	0	0	0	0	0	0	0	0	21336.9355	21336.9434	0	0
Acetylene	0	0	0	0	0	0	0	0	0	0	0	0	0	0
Ethylene	0	0	0	0	0	0	0	0	0	0	1041.2955	1041.2961	0	0
Ethane	0	0	0	0	0	0	0	0	0	0	1948.759	1948.76	0	0
Propane	0	0	0	0	0	0	0	0	0	0	0	0	0	0
Water	0	0	0	0	0	0	0	25052.5488	66806.3047	66806.3047	62887.375	62887.4023	0	0
Sulphur	0	0	0	0	0	0	0	0	0	0	3.0449	0	0	0
Carbonyl Sulfide	0	0	0	0	0	0	0	0	0	0	0	0	0	0
Hydrogen Sulfide	0	0	0	0	0	0	0	0	0	0	35.064	35.064	0	0
Ammonia	0	0	0	0	0	0	0	0	0	0	1312.588	1312.5884	0	0
HydrogenChloride	0	0	0	0	0	0	0	0	0	0	18.5296	18.5296	0	0
Calcium Oxide	0	0	0	0	0	0	0	0	0	0	4960.4033	4960.4048	4960.4048	4960.4048
Benzene	0	0	0	0	0	0	0	0	0	0	8488.3242	8488.3301	0	0
Naphthalene	0	0	0	0	0	0	0	0	0	0	3977.6028	3977.6035	0	0
Hybrid Poplar Ch	0	0	0	0	0	0	0	183718.703	183718.703	183718.703	0	0	0	0
Sulfur Dioxide	0	0	0	0	0	0	0	0	0	0	0	0	0	0
Hydrogen Cyanide	0	0	0	0	0	0	0	0	0	0	0	0	0	0
Nitric Oxide	0	0	0	0	0	0	0	0	0	0	0	0	0	0
Methanol	0	0	0	0	0	0	0	0	0	0	0	0	0	0
Ethanol	0	0	0	0	0	0	0	0	0	0	0	0	0	0
Isopropanol	0	0	0	0	0	0	0	0	0	0	0	0	0	0
N-Propanol	0	0	0	0	0	0	0	0	0	0	0	0	0	0
Isobutanol	0	0	0	0	0	0	0	0	0	0	0	0	0	0
N-Butanol	0	0	0	0	0	0	0	0	0	0	0	0	0	0
1-Pentanol	0	0	0	0	0	0	0	0	0	0	0	0	0	0

Table B.2. (contd)

Stream No.	308	309	310	311	312	313	314	315	330	335	336	337	340	341
Temp F	90	196.9097	60	123.5755	1600	371.8523	3741.1391	2743.6979	1600	1383	443.4863	276.2184	116.4856	116.4856
Pres psia	60	60	14.696	20	330	25	25	25	330	327	326	325	324	324
Enth MMBtu/h	-62.541	-112.02	-0.48446	1.2888	8.3447	9.6334	9.634	-31.834	-824.05	-775.49	-896.18	-922.85	-58296	-57713
Vapor mass fraction	0	0	1	1	1	1	1	1	1	1	1	0.97371	0	0
Total lb/h	9179.9326	14140.3379	115403.398	115403.398	7510.1357	122913.539	122913.477	122913.5	290428	290427.5	290427.5	290427.5	8639493	8553097
Flowrates in lb/h														
Oxygen	0	0	26879.2227	26879.2227	307.1115	27186.334	3541.3291	3541.3301	0	0	0	0	0	0
Nitrogen	0	0	88524.1797	88524.1797	37.5337	88561.7109	88195.7969	88195.8203	82.8463	838.5153	838.5153	838.5153	5.4233	5.369
Argon	0	0	0	0	0	0	0	0	154.138	154.1381	154.1381	154.1381	2.8519	2.8234
Carbon	0	0	0	0	6254.9395	6254.9395	0.0002	0.0002	0	0	0	0	0	0
Hydrogen	0	0	0	0	907.5061	907.5061	10.4677	10.4677	3655.0701	8376.3105	8376.3105	8376.3105	104.795	103.747
Carbon Monoxide	0	0	0	0	0	0	980.4257	980.4258	49736.6719	82535.7734	82535.7734	82535.7734	1129.4772	1118.1825
Carbon Dioxide	0	0	0	0	0	0	21378.709	21378.7129	135752.594	135752.672	135752.672	135752.672	39684.6523	39287.8047
Methane	0	0	0	0	0	0	0	0	21336.9297	17069.5547	17069.5547	17069.5547	280.8862	278.0774
Acetylene	0	0	0	0	0	0	0	0	0	0	0	0	0	0
Ethylene	0	0	0	0	0	0	0	0	1041.295	520.6481	520.6481	520.6481	117.1997	116.0277
Ethane	0	0	0	0	0	0	0	0	1948.7582	194.8761	194.8761	194.8761	37.2409	36.8685
Propane	0	0	0	0	0	0	0	0	0	0	0	0	0	0
Water	9179.9326	9179.9326	0	0	0	0	8016.8018	8016.8037	62887.3594	41792.2578	41792.2578	41792.2578	8559217	8473625
Sulphur	0	0	0	0	3.0449	3.0449	0.0002	0.0002	0	0	0	0	0	0
Carbonyl Sulfide	0	0	0	0	0	0	0	0	0	0	0	0	0	0
Hydrogen Sulfide	0	0	0	0	0	0	0	0	35.064	35.064	35.064	35.064	24.5355	24.2902
Ammonia	0	0	0	0	0	0	0	0	1312.5869	393.7765	393.7765	393.7765	31956.9629	31637.3926
HydrogenChloride	0	0	0	0	0	0	0	0	18.5295	18.5296	18.5296	18.5296	1852.9353	1834.4059
Calcium Oxide	0	4960.4048	0	0	0	0	0	0	0	0	0	0	0	0
Benzene	0	0	0	0	0	0	0	0	8488.3174	2546.499	2546.499	2546.499	3839.2632	3800.8706
Naphthalene	0	0	0	0	0	0	0	0	3977.6001	198.8803	198.8803	198.8803	1239.5193	1227.1241
Hybrid Poplar Ch	0	0	0	0	0	0	0	0	0	0	0	0	0	0
Sulfur Dioxide	0	0	0	0	0	0	6.0849	6.0849	0	0	0	0	0	0
Hydrogen Cyanide	0	0	0	0	0	0	0	0	0	0	0	0	0	0
Nitric Oxide	0	0	0	0	0	0	783.8491	783.8492	0	0	0	0	0	0
Methanol	0	0	0	0	0	0	0	0	0	0	0	0	0	0
Ethanol	0	0	0	0	0	0	0	0	0	0	0	0	0	0
Isopropanol	0	0	0	0	0	0	0	0	0	0	0	0	0	0
N-Propanol	0	0	0	0	0	0	0	0	0	0	0	0	0	0
Isobutanol	0	0	0	0	0	0	0	0	0	0	0	0	0	0
N-Butanol	0	0	0	0	0	0	0	0	0	0	0	0	0	0
1-Pentanol	0	0	0	0	0	0	0	0	0	0	0	0	0	0

Table B.2. (contd)

Stream No.	342	343	344	380	425	426	427	428	429	430	431	432	433	434
Temp F	110	110	110.0031	116.4856	188.2762	140	105	105	105	120	120	120	707.0002	707.0002
Pres psia	324	440	324	324	465	464	464	464	464	464	445	445	445	440
Enth MMBtu/h	-57765	-305.68	-58070	-697.49	-691.09	-695.62	-699.61	-4.4756	-695.13	-693.74	0	-693.69	-636.28	-0.0035631
Vapor mass fraction	0.0031985	0	0.0031665	1	1	1	0.99662	0	1	1	0	1	1	1
Total lb/h	8553097	45000	8598097	249032.25	249032.266	249032.266	249032.266	841.976	248190.281	248190.281	0	248190.281	248190.297	34.8118
Flowrates in lb/h														
Oxygen	0	0	0	0	0	0	0	0	0	0	0	0	0	0
Nitrogen	5.369	0	5.369	838.4609	838.4611	838.4611	838.4611	0.0022	838.4589	838.4589	0	838.4589	838.4589	0
Argon	2.8234	0	2.8234	154.1096	154.1096	154.1096	154.1096	0.001	154.1086	154.1086	0	154.1086	154.1086	0
Carbon	0	0	0	0	0	0	0	0	0	0	0	0	0	0
Hydrogen	103.747	0	103.747	8375.2607	8375.2617	8375.2617	8375.2617	0.0098	8375.252	8375.252	0	8375.252	8375.252	0
Carbon Monoxide	1118.1825	0	1118.1825	82524.4297	82524.4766	82524.4766	82524.4766	0.2315	82524.2344	82524.2344	0	82524.2344	82524.2266	0
Carbon Dioxide	39287.8047	0	39287.8086	135356	135356	135356	135356	8.6833	135347.188	135347.188	0	135347.188	135347.203	0
Methane	278.0774	0	278.0774	17066.7441	17066.748	17066.748	17066.748	0.1913	17066.5527	17066.5527	0	17066.5527	17066.5508	0
Acetylene	0	0	0	0	0	0	0	0	0	0	0	0	0	0
Ethylene	116.0277	0	116.0277	519.4758	519.4761	519.4761	519.4761	0.0251	519.451	519.451	0	519.451	519.451	0
Ethane	36.8685	0	36.8685	194.5036	194.5037	194.5037	194.5037	0.0135	194.4902	194.4902	0	194.4902	194.4902	0
Propane	0	0	0	0	0	0	0	0	0	0	0	0	0	0
Water	8473625	45000	8518625	1199.7528	1199.7526	1199.7526	1199.7526	661.3782	538.381	538.381	0	538.381	538.381	0
Sulphur	0	0	0	0	0	0	0	0	0	0	0	0	0	0
Carbonyl Sulfide	0	0	0	0	0	0	0	0	0	0	0	0	0	0
Hydrogen Sulfide	24.2902	0	24.2902	34.8187	34.8187	34.8187	34.8187	0.0069	34.8118	34.8118	0	34.8118	34.8118	34.8118
Ammonia	31637.3926	0	31637.3945	74.2077	74.2077	74.2077	74.2077	0.0236	74.1841	74.1841	0	74.1841	74.1841	0
HydrogenChloride	1834.4059	0	1834.4059	0	0	0	0	0	0	0	0	0	0	0
Calcium Oxide	0	0	0	0	0	0	0	0	0	0	0	0	0	0
Benzene	3800.8706	0	3800.8706	2508.1113	2508.1118	2508.1118	2508.1118	34.8027	2473.3093	2473.3093	0	2473.3093	2473.3091	0
Naphthalene	1227.1241	0	1227.1241	186.4863	186.4864	186.4864	186.4864	136.6067	49.881	49.881	0	49.881	49.8811	0
Hybrid Poplar Ch	0	0	0	0	0	0	0	0	0	0	0	0	0	0
Sulfur Dioxide	0	0	0	0	0	0	0	0	0	0	0	0	0	0
Hydrogen Cyanide	0	0	0	0	0	0	0	0	0	0	0	0	0	0
Nitric Oxide	0	0	0	0	0	0	0	0	0	0	0	0	0	0
Methanol	0	0	0	0	0	0	0	0	0	0	0	0	0	0
Ethanol	0	0	0	0	0	0	0	0	0	0	0	0	0	0
Isopropanol	0	0	0	0	0	0	0	0	0	0	0	0	0	0
N-Propanol	0	0	0	0	0	0	0	0	0	0	0	0	0	0
Isobutanol	0	0	0	0	0	0	0	0	0	0	0	0	0	0
N-Butanol	0	0	0	0	0	0	0	0	0	0	0	0	0	0
1-Pentanol	0	0	0	0	0	0	0	0	0	0	0	0	0	0

Table B.2. (contd)

Stream No.	435	440	441	443	445	446	447	448	449	450	451	452	453	471
Temp F	707.0002	700.6349	975	1652	1345.5765	1181.9598	300.0202	150	110	110	120	120	58.5657	275.956
Pres psia	440	440	435	420	419	419	419	419	416.5	416.5	411.5	411.5	22	800
Enth MMBtu/h	-636.28	-966.46	-929.12	-757.04	-802.88	-826.65	-962.47	-1024.3	-1032.1	-619.96	-231.7	-388.41	-388.41	-220
Vapor mass fraction	1	1	1	1	1	1	0.94339	0.80767	0.80312	1	1	0.99413	0.99693	1
Total lb/h	248155.406	308155.469	308155.469	308155	308155	308155	308155	308155	308155	247485	147032.703	100452.055	100452.039	147032.734
Flowrates in lb/h														
Oxygen	0	0	0	0	0	0	0	0	0	0	0	0	0	0
Nitrogen	838.4583	838.4589	838.4589	886.7114	886.7114	886.7114	886.7114	886.7114	886.7114	886.7114	886.7114	0	0	886.7114
Argon	154.1085	154.1086	154.1086	154.1086	154.1086	154.1086	154.1086	154.1086	154.1086	154.1086	154.1086	0	0	154.1086
Carbon	0	0	0	0	0	0	0	0	0	0	0	0	0	0
Hydrogen	8375.249	8375.252	8375.252	10583.9385	10583.9375	10583.9375	10583.9375	10583.9375	10583.9404	10583.9365	10583.9404	0	0	10583.9365
Carbon Monoxide	82524.1953	82524.2344	82524.2344	125239.344	125239.344	125239.344	125239.344	125239.344	125239.305	125239.344	125239.305	0	0	125239.344
Carbon Dioxide	135347.156	135347.188	135347.188	100691.008	100691	100691	100691	100691	100691	100691	100691	99684.0781	99684.0625	100691.14
Methane	17066.5488	17066.5527	17066.5527	9144.5645	9144.5645	9144.5645	9144.5645	9144.5645	9144.5645	9144.5645	9144.5645	0	0	9144.5645
Acetylene	0	0	0	0	0	0	0	0	0	0	0	0	0	0
Ethylene	519.4506	519.451	519.451	0.4541	0.4541	0.4541	0.4541	0.4541	0.4541	0.4541	0.4541	0	0	0.4541
Ethane	194.4901	194.4902	194.4902	1.0472	1.0472	1.0472	1.0472	1.0472	1.0472	1.0472	1.0472	0	0	1.0472
Propane	0	0	0	0	0	0	0	0	0	0	0	0	0	0
Water	538.3807	60538.3789	60538.3789	61438	61438	61438	61438	61438	61438	767.9789	0	767.9789	767.9795	0
Sulphur	0	0	0	0	0	0	0	0	0	0	0	0	0	0
Carbonyl Sulfide	0	0	0	0	0	0	0	0	0	0	0	0	0	0
Hydrogen Sulfide	0	0	0	0	0	0	0	0	0	0	0	0	0	0
Ammonia	74.184	74.1841	74.1841	15.3483	15.3483	15.3483	15.3483	15.3483	15.3483	15.3483	15.3483	0	0	15.3483
HydrogenChloride	0	0	0	0	0	0	0	0	0	0	0	0	0	0
Calcium Oxide	0	0	0	0	0	0	0	0	0	0	0	0	0	0
Benzene	2473.3081	2473.3093	2473.3093	0	0	0	0	0	0	0	0	0	0	0
Naphthalene	49.881	49.881	49.881	0	0	0	0	0	0	0	0	0	0	0
Hybrid Poplar Ch	0	0	0	0	0	0	0	0	0	0	0	0	0	0
Sulfur Dioxide	0	0	0	0	0	0	0	0	0	0	0	0	0	0
Hydrogen Cyanide	0	0	0	0.2669	0.2669	0.2669	0.2669	0.2669	0.2669	0.2669	0.2669	0	0	0.2669
Nitric Oxide	0	0	0	0	0	0	0	0	0	0	0	0	0	0
Methanol	0	0	0	0.0662	0.0662	0.0662	0.0662	0.0662	0.0662	0.0662	0.0662	0	0	0.0662
Ethanol	0	0	0	0	0	0	0	0	0	0	0	0	0	0
Isopropanol	0	0	0	0	0	0	0	0	0	0	0	0	0	0
N-Propanol	0	0	0	0	0	0	0	0	0	0	0	0	0	0
Isobutanol	0	0	0	0	0	0	0	0	0	0	0	0	0	0
N-Butanol	0	0	0	0	0	0	0	0	0	0	0	0	0	0
1-Pentanol	0	0	0	0	0	0	0	0	0	0	0	0	0	0

Table B.2. (contd)

Stream No.	472	473	474	475	490	491	493	494	495	496	497	498	499	510
Temp F	140	233.8242	140	259.9529	60	124.5558	110.0473	1800	1800	1350.5909	951.462	274.1718	311.9207	400
Pres psia	800	1200	1200	2000	14.696	20	16	16	16	15	14	13	15	1995
Enth MMBtu/h	-230.27	-223.14	-230.31	-220.98	-1.2011	3.2632	-48.925	-221.42	-221.42	-265.57	-302.91	-361.71	-358.57	-1135.8
Vapor mass fraction	1	1	1	1	1	1	1	1	1	1	1	1	1	1
Total lb/h	147032.734	147032.734	147032.734	147032.703	286107.344	286107.344	310052.375	310052	310052	310052	310052	310052	310052	716823
Flowrates in lb/h														
Oxygen	0	0	0	0	66638.8594	66638.8594	66638.8594	8146.0688	8146.0688	8146.0688	8145.9722	8145.9722	8145.9731	0
Nitrogen	886.7114	886.7114	886.7114	886.7112	219468.469	219468.469	220115	220108.563	220108.563	220108.563	220108.563	220108.594	220108.594	21820.1797
Argon	154.1086	154.1086	154.1086	154.1086	0	0	112.3462	112.3462	112.3462	112.3462	112.3462	112.3462	112.3462	3592.5518
Carbon	0	0	0	0	0	0	0	0	0	0	0	0	0	0
Hydrogen	10583.9365	10583.9365	10583.9365	10583.9336	0	0	303.6196	0.0009	0.0009	0.0009	0.0009	0.0009	0.0009	20416.5176
Carbon Monoxide	125239.344	125239.344	125239.344	125239.32	0	0	4827.6704	0.0121	0.0121	0.0121	0.0121	0.0121	0.0121	280155.375
Carbon Dioxide	1006.9114	1006.9114	1006.9114	1006.9109	0	0	3239.5835	48511.5234	48511.5234	48511.5234	48511.5391	48511.5391	48511.5586	1550.192
Methane	9144.5645	9144.5645	9144.5645	9144.5635	0	0	11930.1758	0.0002	0.0002	0.0002	0.0002	0.0002	0.0002	367524.344
Acetylene	0	0	0	0	0	0	0	0	0	0	0	0	0	0
Ethylene	0.4541	0.4541	0.4541	0.4541	0	0	0.331	0.0003	0.0003	0.0003	0.0003	0.0003	0.0003	8.4128
Ethane	1.0472	1.0472	1.0472	1.0472	0	0	548.7436	0.0003	0.0003	0.0003	0.0003	0.0003	0.0003	12438.6396
Propane	0	0	0	0	0	0	0	0	0	0	0	0	0	0
Water	0	0	0	0	0	0	95.2335	33139.5938	33139.5938	33139.5938	33139.6797	33139.6797	33139.6719	0
Sulphur	0	0	0	0	0	0	0	0	0	0	0	0	0	0
Carbonyl Sulfide	0	0	0	0	0	0	0	0	0	0	0	0	0	0
Hydrogen Sulfide	0	0	0	0	0	0	0	0	0	0	0	0	0	0
Ammonia	15.3483	15.3483	15.3483	15.3482	0	0	11.1828	0.0002	0.0002	0.0002	0.0002	0.0002	0.0002	67.9379
HydrogenChloride	0	0	0	0	0	0	0	0	0	0	0	0	0	0
Calcium Oxide	0	0	0	0	0	0	0	0	0	0	0	0	0	0
Benzene	0	0	0	0	0	0	0	0	0	0	0	0	0	0
Naphthalene	0	0	0	0	0	0	0	0	0	0	0	0	0	0
Hybrid Poplar Ch	0	0	0	0	0	0	0	0	0	0	0	0	0	0
Sulfur Dioxide	0	0	0	0	0	0	0	0	0	0	0	0	0	0
Hydrogen Cyanide	0.2669	0.2669	0.2669	0.2669	0	0	0.1945	0.0003	0.0003	0.0003	0.0003	0.0003	0.0003	0.6524
Nitric Oxide	0	0	0	0	0	0	0	33.6758	33.6758	33.6758	33.6756	33.6756	33.6755	0
Methanol	0.0662	0.0662	0.0662	0.0662	0	0	1726.9731	0.0003	0.0003	0.0003	0.0003	0.0003	0.0003	2631.7458
Ethanol	0	0	0	0	0	0	445.799	0.0005	0.0005	0.0005	0.0005	0.0005	0.0005	5707.2822
Isopropanol	0	0	0	0	0	0	0	0	0	0	0	0	0	0
N-Propanol	0	0	0	0	0	0	43.4006	0.0006	0.0006	0.0006	0.0006	0.0006	0.0006	668.366
Isobutanol	0	0	0	0	0	0	0	0	0	0	0	0	0	0
N-Butanol	0	0	0	0	0	0	9.0992	0.0007	0.0007	0.0007	0.0007	0.0007	0.0007	160.3787
1-Pentanol	0	0	0	0	0	0	4.1408	0.0007	0.0007	0.0007	0.0007	0.0007	0.0007	79.7522

Table B.2. (contd)

Stream No.	512	516	517	518	519	520	521	523	524	525	528	530	551	552
Temp F	398.5988	570	570.0002	332.9341	125	110	109.987	108.9517	108.9517	110.0237	110.0237	110.0237	108.9517	108.9517
Pres psia	1995	1995	1995	1990	1980	1975	1974	1974	1974	35	35	35	1974	1974
Enth MMBtu/h	-1168.6	-1306	-1306	-1410.6	-1524.6	-1533	-1533	-1292.3	-240.72	-240.72	-228.73	-11.991	-51.692	-1240.6
Vapor mass fraction	1	1	1	1	0.90085	0.89408	0.89407	1	0	0.054273	0	1	1	1
Total lb/h	729095	729097.25	729097.125	729107	729107	729107	729107	650565	78542	78542	74279.2891	4262.6914	26022.5918	624542.188
Flowrates in lb/h														
Oxygen	0	0	0	0	0	0	0	0	0	0	0	0	0	0
Nitrogen	21820.1738	21820.1797	21820.1777	21820.8398	21820.8398	21820.8398	21820.8398	21805.6895	15.1514	15.1515	0.0347	15.1167	872.2275	20933.4609
Argon	3592.5518	3592.5518	3592.5505	3592.6443	3592.6443	3592.6443	3592.6438	3581.7087	10.9357	10.9358	0.1288	10.807	143.2683	3438.4404
Carbon	0	0	0	0	0	0	0	0	0	0	0	0	0	0
Hydrogen	20416.5176	10249.5361	10249.5352	10249.0889	10249.0889	10249.0889	10249.0898	10242.0273	7.0609	7.0609	0.0147	7.0462	409.6811	9832.3457
Carbon Monoxide	280155.313	161542.484	161542.406	161542.328	161542.328	161542.328	161542.297	161370.813	171.5301	171.5301	0.6415	170.8886	6454.832	154916
Carbon Dioxide	1550.1919	58774.5	58774.4844	58774.4492	58774.4492	58774.4492	58774.4492	56591.5234	2182.9258	2182.926	408.497	1774.4286	2263.6609	54327.8594
Methane	367524.313	374745.125	374745.094	374754.25	374754.25	374754.25	374754.313	373311.625	1442.6525	1442.652	24.0583	1418.594	14932.4648	358379.156
Acetylene	0	0	0	0	0	0	0	0	0	0	0	0	0	0
Ethylene	8.4128	8.4128	8.4128	8.4129	8.4129	8.4129	8.4129	8.2902	0.1227	0.1227	0.01	0.1127	0.3316	7.9586
Ethane	12438.6387	13190.5381	13190.542	13190.7422	13190.7422	13190.7422	13190.7402	12955.7793	234.9632	234.9632	24.8815	210.0817	518.2311	12437.5488
Propane	0	0	0	0	0	0	0	0	0	0	0	0	0	0
Water	0	9348.4795	9348.4805	9348.4941	9348.4941	9348.4941	9348.4932	1009.5903	8338.8994	8338.8994	8248.7803	90.1194	40.3836	969.2066
Sulphur	0	0	0	0	0	0	0	0	0	0	0	0	0	0
Carbonyl Sulfide	0	0	0	0	0	0	0	0	0	0	0	0	0	0
Hydrogen Sulfide	0	0	0	0	0	0	0	0	0	0	0	0	0	0
Ammonia	67.9379	67.9379	67.9379	67.9386	67.9386	67.9386	67.9386	54.7806	13.158	13.158	8.4246	4.7334	2.1912	52.5894
HydrogenChloride	0	0	0	0	0	0	0	0	0	0	0	0	0	0
Calcium Oxide	0	0	0	0	0	0	0	0	0	0	0	0	0	0
Benzene	0	0	0	0	0	0	0	0	0	0	0	0	0	0
Naphthalene	0	0	0	0	0	0	0	0	0	0	0	0	0	0
Hybrid Poplar Ch	0	0	0	0	0	0	0	0	0	0	0	0	0	0
Sulfur Dioxide	0	0	0	0	0	0	0	0	0	0	0	0	0	0
Hydrogen Cyanide	0.6524	0.6524	0.6524	0.6524	0.6524	0.6524	0.6524	0.4015	0.2509	0.2509	0.2227	0.0282	0.0161	0.3855
Nitric Oxide	0	0	0	0	0	0	0	0	0	0	0	0	0	0
Methanol	14869.9063	17377.7422	17377.7344	17377.7383	17377.7383	17377.7383	17377.7402	2741.3027	14636.4287	14636.4297	14458.3926	178.0387	109.6521	2631.6504
Ethanol	5741.4941	44406.1289	44406.1211	44406.2461	44406.2461	44406.2461	44406.25	5945.0063	38461.2227	38461.2188	38118.3906	342.8346	237.8003	5707.2061
Isopropanol	0	0	0	0	0	0	0	0	0	0	0	0	0	0
N-Propanol	668.6248	8631.6484	8631.6475	8631.6592	8631.6592	8631.6592	8631.6582	696.2037	7935.4526	7935.4531	7903.7603	31.6934	27.8481	668.3555
Isobutanol	0	0	0	0	0	0	0	0	0	0	0	0	0	0
N-Butanol	160.3787	3561.7605	3561.7603	3561.7659	3561.7659	3561.7659	3561.7661	167.0592	3394.7053	3394.7051	3388.8984	5.807	6.6824	160.3768
1-Pentanol	79.7522	1779.5919	1779.5916	1779.5946	1779.5946	1779.5946	1779.5941	83.0744	1696.5195	1696.52	1694.1589	2.3606	3.323	79.7514

Table B.2. (contd)

Stream No.	553	554	555	556	559	560	561	601	605	606	610	611	612	620
Temp F	230	63.3966	130	132.3299	152.5568	189.1794	550	149.5734	195.2473	194.8802	152.0194	152.0194	152.0194	197.9073
Pres psia	1974	22	1974	2000	2000	2000	2000	23	26.7	26.6999	16	16	16	22
Enth MMBtu/h	-213.26	-213.26	-1020.1	-1019.4	-1240.4	-38.617	-32.758	-3.6449	-219.55	-219.55	-43.042	-4.3042	-38.738	-121.36
Vapor mass fraction	0.98797	0.98768	1	1	1	0.0003125	1	1	0	0	0	0	0	0
Total lb/h	54753.7891	54753.7891	569788.375	569789	716823	12272.6377	12272.6377	1217.5072	73061.7813	73061.7813	13636.2656	1363.6266	12272.6416	51176.9258
Flowrates in lb/h														
Oxygen	0	0	0	0	0	0	0	0	0	0	0	0	0	0
Nitrogen	0	0	20933.4609	20933.4668	21820.1797	0	0	0.0347	0	0	0	0	0	0
Argon	0	0	3438.4399	3438.4412	3592.5518	0	0	0.1288	0	0	0	0	0	0
Carbon	0	0	0	0	0	0	0	0	0	0	0	0	0	0
Hydrogen	0	0	9832.3467	9832.3486	20416.5176	0	0	0.0147	0	0	0	0	0	0
Carbon Monoxide	0	0	154916	154916.016	280155.375	0	0	0.6415	0	0	0	0	0	0
Carbon Dioxide	53784.582	53784.582	543.2805	543.2808	1550.192	0	0	408.497	0	0	0	0	0	0
Methane	0	0	358379.094	358379.25	367524.344	0	0	24.0583	0	0	0	0	0	0
Acetylene	0	0	0	0	0	0	0	0	0	0	0	0	0	0
Ethylene	0	0	7.9586	7.9586	8.4128	0	0	0.01	0	0	0	0	0	0
Ethane	0	0	12437.5498	12437.5518	12438.6396	0	0	24.8815	0	0	0	0	0	0
Propane	0	0	0	0	0	0	0	0	0	0	0	0	0	0
Water	969.2066	969.2065	0	0	0	0	0	0.2125	8248.5674	8248.5674	0	0	0	0
Sulphur	0	0	0	0	0	0	0	0	0	0	0	0	0	0
Carbonyl Sulfide	0	0	0	0	0	0	0	0	0	0	0	0	0	0
Hydrogen Sulfide	0	0	0	0	0	0	0	0	0	0	0	0	0	0
Ammonia	0	0	52.5894	52.5894	67.9379	0	0	8.4246	0	0	0	0	0	0
HydrogenChloride	0	0	0	0	0	0	0	0	0	0	0	0	0	0
Calcium Oxide	0	0	0	0	0	0	0	0	0	0	0	0	0	0
Benzene	0	0	0	0	0	0	0	0	0	0	0	0	0	0
Naphthalene	0	0	0	0	0	0	0	0	0	0	0	0	0	0
Hybrid Poplar Ch	0	0	0	0	0	0	0	0	0	0	0	0	0	0
Sulfur Dioxide	0	0	0	0	0	0	0	0	0	0	0	0	0	0
Hydrogen Cyanide	0	0	0.3855	0.3855	0.6524	0	0	0.2227	0	0	0	0	0	0
Nitric Oxide	0	0	0	0	0	0	0	0	0	0	0	0	0	0
Methanol	0	0	2631.6499	2631.6511	2631.7458	12238.166	12238.166	722.9219	13735.4697	13735.4697	13597.9639	1359.7964	12238.1699	137.5055
Ethanol	0	0	5707.208	5707.208	5707.2822	34.2131	34.2131	27.4586	38090.9297	38090.9297	38.0146	3.8015	34.2131	38052.8984
Isopropanol	0	0	0	0	0	0	0	0	0	0	0	0	0	0
N-Propanol	0	0	668.3553	668.3557	668.366	0.2587	0.2587	0.0005	7903.7593	7903.7593	0.2874	0.0287	0.2587	7903.4678
Isobutanol	0	0	0	0	0	0	0	0	0	0	0	0	0	0
N-Butanol	0	0	160.3767	160.3768	160.3787	0	0	0	3388.8984	3388.8984	0	0	0	3388.897
1-Pentanol	0	0	79.7514	79.7514	79.7522	0	0	0	1694.1589	1694.1589	0	0	0	1694.1578

Table B.2. (contd)

Stream No.	621	622	623	624	625	631	636	641	646	651	656	702	703	704
Temp F	195.172	195.172	188.5	188.4997	195.172	176.7373	230.7036	207.8559	258.1927	245.1681	291.597	575.2682	575.2682	575.2663
Pres psia	26.6999	23	23	22.9999	23	16	19	15	18	15	18	1280	1280	1280
Enth MMBtu/h	-187.5	-158.41	-164.58	-164.58	-55.327	-96.622	-25.013	-16.317	-8.7232	-6.0211	-2.691	-853.48	-786.6	-1640.1
Vapor mass fraction	1	0.22913	1.27E-06	0	0	0	0	0	0	0	0	1	1	1
Total lb/h	73061.7813	64813.207	64813.2188	64813.2148	8248.5693	38250.2969	12926.6484	7852.7217	5073.9277	3378.0908	1695.8357	150000	138246.609	288246.594
Flowrates in lb/h														
Oxygen	0	0	0	0	0	0	0	0	0	0	0	0	0	0
Nitrogen	0	0	0	0	0	0	0	0	0	0	0	0	0	0
Argon	0	0	0	0	0	0	0	0	0	0	0	0	0	0
Carbon	0	0	0	0	0	0	0	0	0	0	0	0	0	0
Hydrogen	0	0	0	0	0	0	0	0	0	0	0	0	0	0
Carbon Monoxide	0	0	0	0	0	0	0	0	0	0	0	0	0	0
Carbon Dioxide	0	0	0	0	0	0	0	0	0	0	0	0	0	0
Methane	0	0	0	0	0	0	0	0	0	0	0	0	0	0
Acetylene	0	0	0	0	0	0	0	0	0	0	0	0	0	0
Ethylene	0	0	0	0	0	0	0	0	0	0	0	0	0	0
Ethane	0	0	0	0	0	0	0	0	0	0	0	0	0	0
Propane	0	0	0	0	0	0	0	0	0	0	0	0	0	0
Water	8248.5674	0	0	0	8248.5693	0	0	0	0	0	0	150000	138246.609	288246.594
Sulphur	0	0	0	0	0	0	0	0	0	0	0	0	0	0
Carbonyl Sulfide	0	0	0	0	0	0	0	0	0	0	0	0	0	0
Hydrogen Sulfide	0	0	0	0	0	0	0	0	0	0	0	0	0	0
Ammonia	0	0	0	0	0	0	0	0	0	0	0	0	0	0
HydrogenChloride	0	0	0	0	0	0	0	0	0	0	0	0	0	0
Calcium Oxide	0	0	0	0	0	0	0	0	0	0	0	0	0	0
Benzene	0	0	0	0	0	0	0	0	0	0	0	0	0	0
Naphthalene	0	0	0	0	0	0	0	0	0	0	0	0	0	0
Hybrid Poplar Ch	0	0	0	0	0	0	0	0	0	0	0	0	0	0
Sulfur Dioxide	0	0	0	0	0	0	0	0	0	0	0	0	0	0
Hydrogen Cyanide	0	0	0	0	0	0	0	0	0	0	0	0	0	0
Nitric Oxide	0	0	0	0	0	0	0	0	0	0	0	0	0	0
Methanol	13735.4697	13735.4678	13735.4697	13735.4697	0	137.3363	0.1693	0.1691	0.0001	0.0001	0	0	0	0
Ethanol	38090.9297	38090.9219	38090.9297	38090.9297	0	38033.8984	19.0137	19.0137	0	0	0	0	0	0
Isopropanol	0	0	0	0	0	0	0	0	0	0	0	0	0	0
N-Propanol	7903.7593	7903.7573	7903.7593	7903.7573	0	79.0639	7824.4082	7816.5908	7.8187	7.8187	0	0	0	0
Isobutanol	0	0	0	0	0	0	0	0	0	0	0	0	0	0
N-Butanol	3388.8984	3388.8979	3388.8984	3388.8979	0	0	3388.8984	16.9475	3371.9507	3368.5759	3.3735	0	0	0
1-Pentanol	1694.1589	1694.1589	1694.1589	1694.1591	0	0	1694.1589	0.0004	1694.1584	1.696	1692.4623	0	0	0

Table B.2. (contd)

Stream No.	706	707	708	710	712	715	718	719	720	721	725	731	732	733
Temp F	575	575	575	575	574.9981	222.1747	574.9981	200	1000	1000	1000	715.252	715.252	715.252
Pres psia	1277.3452	1277.3452	1277.3452	1277.3452	1277.3452	35	1277.345	1277.345	1265	1265	1265	450	450	450
Enth MMBtu/h	-1623.7	-827.09	-796.57	-18.117	0	0	-18.117	-19.32	-781.17	-752.34	-1533.5	-1570.3	-330.17	-229.77
Vapor mass fraction	1	1	1	0	1	1	0	0	1	1	1	1	1	1
Total lb/h	285364.125	145364.141	140000	2882.4702	0	0	2882.47	2882.4702	145364	140000	285364	285364	60000	41754
Flowrates in lb/h														
Oxygen	0	0	0	0	0	0	0	0	0	0	0	0	0	0
Nitrogen	0	0	0	0	0	0	0	0	0	0	0	0	0	0
Argon	0	0	0	0	0	0	0	0	0	0	0	0	0	0
Carbon	0	0	0	0	0	0	0	0	0	0	0	0	0	0
Hydrogen	0	0	0	0	0	0	0	0	0	0	0	0	0	0
Carbon Monoxide	0	0	0	0	0	0	0	0	0	0	0	0	0	0
Carbon Dioxide	0	0	0	0	0	0	0	0	0	0	0	0	0	0
Methane	0	0	0	0	0	0	0	0	0	0	0	0	0	0
Acetylene	0	0	0	0	0	0	0	0	0	0	0	0	0	0
Ethylene	0	0	0	0	0	0	0	0	0	0	0	0	0	0
Ethane	0	0	0	0	0	0	0	0	0	0	0	0	0	0
Propane	0	0	0	0	0	0	0	0	0	0	0	0	0	0
Water	285364.125	145364.141	140000	2882.4702	0	0	2882.47	2882.4702	145364	140000	285364	285364	60000	41754
Sulphur	0	0	0	0	0	0	0	0	0	0	0	0	0	0
Carbonyl Sulfide	0	0	0	0	0	0	0	0	0	0	0	0	0	0
Hydrogen Sulfide	0	0	0	0	0	0	0	0	0	0	0	0	0	0
Ammonia	0	0	0	0	0	0	0	0	0	0	0	0	0	0
HydrogenChloride	0	0	0	0	0	0	0	0	0	0	0	0	0	0
Calcium Oxide	0	0	0	0	0	0	0	0	0	0	0	0	0	0
Benzene	0	0	0	0	0	0	0	0	0	0	0	0	0	0
Naphthalene	0	0	0	0	0	0	0	0	0	0	0	0	0	0
Hybrid Poplar Ch	0	0	0	0	0	0	0	0	0	0	0	0	0	0
Sulfur Dioxide	0	0	0	0	0	0	0	0	0	0	0	0	0	0
Hydrogen Cyanide	0	0	0	0	0	0	0	0	0	0	0	0	0	0
Nitric Oxide	0	0	0	0	0	0	0	0	0	0	0	0	0	0
Methanol	0	0	0	0	0	0	0	0	0	0	0	0	0	0
Ethanol	0	0	0	0	0	0	0	0	0	0	0	0	0	0
Isopropanol	0	0	0	0	0	0	0	0	0	0	0	0	0	0
N-Propanol	0	0	0	0	0	0	0	0	0	0	0	0	0	0
Isobutanol	0	0	0	0	0	0	0	0	0	0	0	0	0	0
N-Butanol	0	0	0	0	0	0	0	0	0	0	0	0	0	0
1-Pentanol	0	0	0	0	0	0	0	0	0	0	0	0	0	0

Table B.2. (contd)

Stream No.	734	736	737	738	739	741	743	744	745	746	751	761	762	770
Temp F	715.252	715.252	456.3709	720	717.3339	277.5191	277.5191	277.5191	277.5191	277.5191	115.5419	115.5419	115.6689	60
Pres psia	450	450	450	450	450	35	35	35	35	35	1.5	1.5	35	60
Enth MMBtu/h	-43.99	-966.39	-778.18	-754.41	-1720.8	-1781.1	-194.53	-1152.4	-365.85	-68.334	-376.13	-436.06	-436.05	-716.01
Vapor mass fraction	1	1	0.99074	1	1	1	1	1	1	1	0.90745	0	0	0
Total lb/h	7994	175616	137159.141	137159.141	312775.156	312775.156	34160	202369	64246.1602	12000	64246.1602	64246.1602	64246.1602	104637
Flowrates in lb/h														
Oxygen	0	0	0	0	0	0	0	0	0	0	0	0	0	0
Nitrogen	0	0	0	0	0	0	0	0	0	0	0	0	0	0
Argon	0	0	0	0	0	0	0	0	0	0	0	0	0	0
Carbon	0	0	0	0	0	0	0	0	0	0	0	0	0	0
Hydrogen	0	0	0	0	0	0	0	0	0	0	0	0	0	0
Carbon Monoxide	0	0	0	0	0	0	0	0	0	0	0	0	0	0
Carbon Dioxide	0	0	0	0	0	0	0	0	0	0	0	0	0	0
Methane	0	0	0	0	0	0	0	0	0	0	0	0	0	0
Acetylene	0	0	0	0	0	0	0	0	0	0	0	0	0	0
Ethylene	0	0	0	0	0	0	0	0	0	0	0	0	0	0
Ethane	0	0	0	0	0	0	0	0	0	0	0	0	0	0
Propane	0	0	0	0	0	0	0	0	0	0	0	0	0	0
Water	7994	175616	137159.141	137159.141	312775.156	312775.156	34160	202369	64246.1602	12000	64246.1602	64246.1602	64246.1602	104637
Sulphur	0	0	0	0	0	0	0	0	0	0	0	0	0	0
Carbonyl Sulfide	0	0	0	0	0	0	0	0	0	0	0	0	0	0
Hydrogen Sulfide	0	0	0	0	0	0	0	0	0	0	0	0	0	0
Ammonia	0	0	0	0	0	0	0	0	0	0	0	0	0	0
HydrogenChloride	0	0	0	0	0	0	0	0	0	0	0	0	0	0
Calcium Oxide	0	0	0	0	0	0	0	0	0	0	0	0	0	0
Benzene	0	0	0	0	0	0	0	0	0	0	0	0	0	0
Naphthalene	0	0	0	0	0	0	0	0	0	0	0	0	0	0
Hybrid Poplar Ch	0	0	0	0	0	0	0	0	0	0	0	0	0	0
Sulfur Dioxide	0	0	0	0	0	0	0	0	0	0	0	0	0	0
Hydrogen Cyanide	0	0	0	0	0	0	0	0	0	0	0	0	0	0
Nitric Oxide	0	0	0	0	0	0	0	0	0	0	0	0	0	0
Methanol	0	0	0	0	0	0	0	0	0	0	0	0	0	0
Ethanol	0	0	0	0	0	0	0	0	0	0	0	0	0	0
Isopropanol	0	0	0	0	0	0	0	0	0	0	0	0	0	0
N-Propanol	0	0	0	0	0	0	0	0	0	0	0	0	0	0
Isobutanol	0	0	0	0	0	0	0	0	0	0	0	0	0	0
N-Butanol	0	0	0	0	0	0	0	0	0	0	0	0	0	0
1-Pentanol	0	0	0	0	0	0	0	0	0	0	0	0	0	0

Table B.2. (contd)

Stream No.	771	772	773	775	776	778	781	782	783	784	792	793	794	795
Temp F	71.5014	259.3462	456	259	259.3462	222.1747	223.7356	223.7356	226.2917	223.7356	575.2682	575.2682	1000	720
Pres psia	60	35	450	35	35	35	450	450	1280.8	450	1280	1280	1265	450
Enth MMBtu/h	-714.81	-226.91	-51.414	-1344.3	-1624.2	-2841.8	-2841.1	-1925.1	-1924.3	-916.03	-853.48	-786.6	-781.17	-754.41
Vapor mass fraction	0	0	0	0	0	0	0	0	0	0	1	1	1	1
Total lb/h	104637	34160	7994	202369	244523	425406.156	425406.156	288247.156	288247.156	137159	150000	138246.609	145364	137159.141
Flowrates in lb/h														
Oxygen	0	0	0	0	0	0	0	0	0	0	0	0	0	0
Nitrogen	0	0	0	0	0	0	0	0	0	0	0	0	0	0
Argon	0	0	0	0	0	0	0	0	0	0	0	0	0	0
Carbon	0	0	0	0	0	0	0	0	0	0	0	0	0	0
Hydrogen	0	0	0	0	0	0	0	0	0	0	0	0	0	0
Carbon Monoxide	0	0	0	0	0	0	0	0	0	0	0	0	0	0
Carbon Dioxide	0	0	0	0	0	0	0	0	0	0	0	0	0	0
Methane	0	0	0	0	0	0	0	0	0	0	0	0	0	0
Acetylene	0	0	0	0	0	0	0	0	0	0	0	0	0	0
Ethylene	0	0	0	0	0	0	0	0	0	0	0	0	0	0
Ethane	0	0	0	0	0	0	0	0	0	0	0	0	0	0
Propane	0	0	0	0	0	0	0	0	0	0	0	0	0	0
Water	104637	34160	7994	202369	244523	425406.156	425406.156	288247.156	288247.156	137159	150000	138246.609	145364	137159.141
Sulphur	0	0	0	0	0	0	0	0	0	0	0	0	0	0
Carbonyl Sulfide	0	0	0	0	0	0	0	0	0	0	0	0	0	0
Hydrogen Sulfide	0	0	0	0	0	0	0	0	0	0	0	0	0	0
Ammonia	0	0	0	0	0	0	0	0	0	0	0	0	0	0
HydrogenChloride	0	0	0	0	0	0	0	0	0	0	0	0	0	0
Calcium Oxide	0	0	0	0	0	0	0	0	0	0	0	0	0	0
Benzene	0	0	0	0	0	0	0	0	0	0	0	0	0	0
Naphthalene	0	0	0	0	0	0	0	0	0	0	0	0	0	0
Hybrid Poplar Ch	0	0	0	0	0	0	0	0	0	0	0	0	0	0
Sulfur Dioxide	0	0	0	0	0	0	0	0	0	0	0	0	0	0
Hydrogen Cyanide	0	0	0	0	0	0	0	0	0	0	0	0	0	0
Nitric Oxide	0	0	0	0	0	0	0	0	0	0	0	0	0	0
Methanol	0	0	0	0	0	0	0	0	0	0	0	0	0	0
Ethanol	0	0	0	0	0	0	0	0	0	0	0	0	0	0
Isopropanol	0	0	0	0	0	0	0	0	0	0	0	0	0	0
N-Propanol	0	0	0	0	0	0	0	0	0	0	0	0	0	0
Isobutanol	0	0	0	0	0	0	0	0	0	0	0	0	0	0
N-Butanol	0	0	0	0	0	0	0	0	0	0	0	0	0	0
1-Pentanol	0	0	0	0	0	0	0	0	0	0	0	0	0	0

Table B.2. (contd)

Stream No.	796	1602	1605	1607	1608	1702	1748	1830	1831	1835	1836	1841	1842	1844
Temp F	1000	44.7393	44.7393	44.7393	44.7393	116.4856	110	90	110	90	110	90	110	90
Pres psia	1265	16	16	16	16	324	416.5	60	60	60	60	65	65	65
Enth MMBtu/h	-752.34	-71.632	-52.188	-17	-2.4441	-582.96	-412.12	-17690	-17638	-2602.7	-2595	-2634.2	-2626.4	-1810.3
Vapor mass fraction	1	0.97452	0.97452	0.97452	0.97452	0	0	0	0	0	0	0	0	0
Total lb/h	140000	32866.4063	23945	7800	1121.4208	86395	60670	2596518.75	2596518.5	382027	382027	386649.563	386649.531	265720.313
Flowrates in lb/h														
Oxygen	0	0	0	0	0	0	0	0	0	0	0	0	0	0
Nitrogen	0	887.3789	646.5046	210.5966	30.2779	0.0542	0	0	0	0	0	0	0	0
Argon	0	154.2041	112.3462	36.5964	5.2615	0.0285	0	0	0	0	0	0	0	0
Carbon	0	0	0	0	0	0	0	0	0	0	0	0	0	0
Hydrogen	0	416.742	303.6196	98.903	14.2195	1.048	0	0	0	0	0	0	0	0
Carbon Monoxide	0	6626.3604	4827.6704	1572.5968	226.0952	11.2948	0	0	0	0	0	0	0	0
Carbon Dioxide	0	4446.584	3239.5835	1055.283	151.72	396.8466	0	0	0	0	0	0	0	0
Methane	0	16375.1113	11930.1758	3886.2134	558.7283	2.8089	0	0	0	0	0	0	0	0
Acetylene	0	0	0	0	0	0	0	0	0	0	0	0	0	0
Ethylene	0	0.4543	0.331	0.1078	0.0155	1.172	0	0	0	0	0	0	0	0
Ethane	0	753.1939	548.7436	178.7513	25.6994	0.3724	0	0	0	0	0	0	0	0
Propane	0	0	0	0	0	0	0	0	0	0	0	0	0	0
Water	140000	130.7155	95.2335	31.022	4.4601	85592.1797	60670	2596518.75	2596518.5	382027	382027	386649.563	386649.531	265720.313
Sulphur	0	0	0	0	0	0	0	0	0	0	0	0	0	0
Carbonyl Sulfide	0	0	0	0	0	0	0	0	0	0	0	0	0	0
Hydrogen Sulfide	0	0	0	0	0	0.2454	0	0	0	0	0	0	0	0
Ammonia	0	15.3492	11.1828	3.6428	0.5237	319.5696	0	0	0	0	0	0	0	0
HydrogenChloride	0	0	0	0	0	18.5294	0	0	0	0	0	0	0	0
Calcium Oxide	0	0	0	0	0	0	0	0	0	0	0	0	0	0
Benzene	0	0	0	0	0	38.3926	0	0	0	0	0	0	0	0
Naphthalene	0	0	0	0	0	12.3952	0	0	0	0	0	0	0	0
Hybrid Poplar Ch	0	0	0	0	0	0	0	0	0	0	0	0	0	0
Sulfur Dioxide	0	0	0	0	0	0	0	0	0	0	0	0	0	0
Hydrogen Cyanide	0	0.2669	0.1945	0.0634	0.0091	0	0	0	0	0	0	0	0	0
Nitric Oxide	0	0	0	0	0	0	0	0	0	0	0	0	0	0
Methanol	0	2370.4077	1726.9731	562.5555	80.8797	0	0	0	0	0	0	0	0	0
Ethanol	0	611.8943	445.799	145.2175	20.8782	0	0	0	0	0	0	0	0	0
Isopropanol	0	0	0	0	0	0	0	0	0	0	0	0	0	0
N-Propanol	0	59.5707	43.4006	14.1376	2.0326	0	0	0	0	0	0	0	0	0
Isobutanol	0	0	0	0	0	0	0	0	0	0	0	0	0	0
N-Butanol	0	12.4893	9.0992	2.964	0.4261	0	0	0	0	0	0	0	0	0
1-Pentanol	0	5.6836	4.1408	1.3488	0.1939	0	0	0	0	0	0	0	0	0

Table B.2. (contd)

Stream No.	1845	1850	1851	1861	1862	1930	1931	1935	1936	1938	1940	1943	1944	1945
Temp F	105	90	110	90	110	715.0002	715.0002	230	400	575.2682	715.0002	573.7587	1000	456.3709
Pres psia	65	65	60	60	60	450	450	1280	1280	1280	450	1265	1265	450
Enth MMBtu/h	-1806.3	-2843.1	-2834.7	-2099.4	-2093.2	-229.77	-229.77	-1000.8	-974.17	-853.48	-330.18	-827.01	-781.17	-778.18
Vapor mass fraction	0	0	0	0	0	1	1	0	0	1	1	1	1	0.99074
Total lb/h	265720.313	417314	417314	308154.563	308154.563	41753.7578	41753.7578	150000	150000	150000	60000	145364	145364	137159.141
Flowrates in lb/h														
Oxygen	0	0	0	0	0	0	0	0	0	0	0	0	0	0
Nitrogen	0	0	0	0	0	0	0	0	0	0	0	0	0	0
Argon	0	0	0	0	0	0	0	0	0	0	0	0	0	0
Carbon	0	0	0	0	0	0	0	0	0	0	0	0	0	0
Hydrogen	0	0	0	0	0	0	0	0	0	0	0	0	0	0
Carbon Monoxide	0	0	0	0	0	0	0	0	0	0	0	0	0	0
Carbon Dioxide	0	0	0	0	0	0	0	0	0	0	0	0	0	0
Methane	0	0	0	0	0	0	0	0	0	0	0	0	0	0
Acetylene	0	0	0	0	0	0	0	0	0	0	0	0	0	0
Ethylene	0	0	0	0	0	0	0	0	0	0	0	0	0	0
Ethane	0	0	0	0	0	0	0	0	0	0	0	0	0	0
Propane	0	0	0	0	0	0	0	0	0	0	0	0	0	0
Water	265720.313	417314	417314	308154.563	308154.563	41753.7578	41753.7578	150000	150000	150000	60000	145364	145364	137159.141
Sulphur	0	0	0	0	0	0	0	0	0	0	0	0	0	0
Carbonyl Sulfide	0	0	0	0	0	0	0	0	0	0	0	0	0	0
Hydrogen Sulfide	0	0	0	0	0	0	0	0	0	0	0	0	0	0
Ammonia	0	0	0	0	0	0	0	0	0	0	0	0	0	0
HydrogenChloride	0	0	0	0	0	0	0	0	0	0	0	0	0	0
Calcium Oxide	0	0	0	0	0	0	0	0	0	0	0	0	0	0
Benzene	0	0	0	0	0	0	0	0	0	0	0	0	0	0
Naphthalene	0	0	0	0	0	0	0	0	0	0	0	0	0	0
Hybrid Poplar Ch	0	0	0	0	0	0	0	0	0	0	0	0	0	0
Sulfur Dioxide	0	0	0	0	0	0	0	0	0	0	0	0	0	0
Hydrogen Cyanide	0	0	0	0	0	0	0	0	0	0	0	0	0	0
Nitric Oxide	0	0	0	0	0	0	0	0	0	0	0	0	0	0
Methanol	0	0	0	0	0	0	0	0	0	0	0	0	0	0
Ethanol	0	0	0	0	0	0	0	0	0	0	0	0	0	0
Isopropanol	0	0	0	0	0	0	0	0	0	0	0	0	0	0
N-Propanol	0	0	0	0	0	0	0	0	0	0	0	0	0	0
Isobutanol	0	0	0	0	0	0	0	0	0	0	0	0	0	0
N-Butanol	0	0	0	0	0	0	0	0	0	0	0	0	0	0
1-Pentanol	0	0	0	0	0	0	0	0	0	0	0	0	0	0

Table B.2. (contd)

Stream No.	1946	1947	1948	1949	1950	1952	1953	1954	1955	1956	1961	1962
Temp F	720	573.7587	1000	230	575.2682	227	456.3709	456.3709	715.0002	573.7568	259.3482	259.3462
Pres psia	450	1265	1265	1280	1280	450	450	450	1265	1265	35	35
Enth MMBtu/h	-754.41	-796.49	-752.34	-922.42	-786.6	-915.58	-778.18	-778.18	-44.398	-50.257	-194.85	-226.91
Vapor mass fraction	1	1	1	0	1	0	0.99074	0.99074	1	1.00E-08	1	0
Total lb/h	137159.141	140000	140000	138246.609	138246.609	137159.141	137159.141	137159.141	7994.1631	7994.1631	34160.6445	34160.6445
Flowrates in lb/h												
Oxygen	0	0	0	0	0	0	0	0	0	0	0	0
Nitrogen	0	0	0	0	0	0	0	0	0	0	0	0
Argon	0	0	0	0	0	0	0	0	0	0	0	0
Carbon	0	0	0	0	0	0	0	0	0	0	0	0
Hydrogen	0	0	0	0	0	0	0	0	0	0	0	0
Carbon Monoxide	0	0	0	0	0	0	0	0	0	0	0	0
Carbon Dioxide	0	0	0	0	0	0	0	0	0	0	0	0
Methane	0	0	0	0	0	0	0	0	0	0	0	0
Acetylene	0	0	0	0	0	0	0	0	0	0	0	0
Ethylene	0	0	0	0	0	0	0	0	0	0	0	0
Ethane	0	0	0	0	0	0	0	0	0	0	0	0
Propane	0	0	0	0	0	0	0	0	0	0	0	0
Water	137159.141	140000	140000	138246.609	138246.609	137159.141	137159.141	137159.141	7994.1631	7994.1631	34160.6445	34160.6445
Sulphur	0	0	0	0	0	0	0	0	0	0	0	0
Carbonyl Sulfide	0	0	0	0	0	0	0	0	0	0	0	0
Hydrogen Sulfide	0	0	0	0	0	0	0	0	0	0	0	0
Ammonia	0	0	0	0	0	0	0	0	0	0	0	0
HydrogenChloride	0	0	0	0	0	0	0	0	0	0	0	0
Calcium Oxide	0	0	0	0	0	0	0	0	0	0	0	0
Benzene	0	0	0	0	0	0	0	0	0	0	0	0
Naphthalene	0	0	0	0	0	0	0	0	0	0	0	0
Hybrid Poplar Ch	0	0	0	0	0	0	0	0	0	0	0	0
Sulfur Dioxide	0	0	0	0	0	0	0	0	0	0	0	0
Hydrogen Cyanide	0	0	0	0	0	0	0	0	0	0	0	0
Nitric Oxide	0	0	0	0	0	0	0	0	0	0	0	0
Methanol	0	0	0	0	0	0	0	0	0	0	0	0
Ethanol	0	0	0	0	0	0	0	0	0	0	0	0
Isopropanol	0	0	0	0	0	0	0	0	0	0	0	0
N-Propanol	0	0	0	0	0	0	0	0	0	0	0	0
Isobutanol	0	0	0	0	0	0	0	0	0	0	0	0
N-Butanol	0	0	0	0	0	0	0	0	0	0	0	0
1-Pentanol	0	0	0	0	0	0	0	0	0	0	0	0



Pacific Northwest
NATIONAL LABORATORY

902 Battelle Boulevard
P.O. Box 999
Richland, WA 99352
1-888-375-PNNL (7665)

www.pnl.gov



U.S. DEPARTMENT OF
ENERGY