

## **ORNL /IAT ARMATURE DIAGNOSTICS DEMONSTRATION TEST REPORT**

S. W. Allison, M. R. Cates, S. M. Goedeke  
Oak Ridge National Laboratory  
Oak Ridge, TN.

M. T. Crawford, S. B. Ferraro  
Institute for Advanced Technology  
Austin, TX.

A. Akerman  
Ditico, Inc.  
Knoxville, TN.

Date Published: March 10, 2005

Prepared by  
OAK RIDGE NATIONAL LABORATORY  
P.O. Box 2008  
Oak Ridge, Tennessee 37831-6283  
managed by  
UT-Battelle, LLC  
for the  
U.S. DEPARTMENT OF ENERGY  
under contract DE-AC05-00OR22

## **Executive Summary**

This test established feasibility for “on the fly” temperature measurements of rail gun projectiles. In addition, an approach for projectile velocity measurement was also demonstrated. Insight was gained into other useful optical and fiberoptic diagnostic approaches.

Instantaneous diagnostics could be critical for achieving further improvements in rail gun operation. They have the potential to enable design enhancements by providing information on the state of the armature and its relationship to the rail as it proceeds down the bore. To that end, the following was accomplished:

1. Optical fibers successfully delivered optical excitation and returned reflective and fluorescence signals as desired.
2. Luminescent coatings survived multiple firings – approximately 40 shots.
3. Optical triggering effectively synchronized an ultraviolet laser pulse to strike the moving armature.
4. Velocity measurements were successfully accomplished by either triggering on the armature front edge using two red diode lasers or by using a single laser and grooved marks a known distance apart on the armature surface.
5. Velocities ranged from 19 to 88 m/s.
6. Temperatures of 30 to 92 C were measured with a precision of about 2 C.
  - a. This precision was achieved with a single laser shot.
  - b. Motion effect was observed but a methodology adequately corrected the result. The correction was only about 2 C.
7. Adequate signal-to-noise and measurement precision was achieved with a single laser shot.

## **Method**

Thermographic phosphors are fine powders that are commonly used for illumination, display, and medical imaging applications. They are designed to efficiently convert incident energy into visible fluorescence. It is also the case that certain characteristics of the fluorescence change noticeably with temperature. This feature is the basis for a wide variety of temperature sensing applications. Usually, a selected phosphor is mixed with an adhesive and coated on the surface of interest. It is illuminated by a pulsed laser or light emitting diode and made to fluoresce. The duration or persistence (termed either the decay time or lifetime) of the fluorescence decreases with temperature. A critical part of any phosphor thermometry system is the optical means for delivering the excitation light to the phosphor and collecting the fluorescence emanating from the coating and conveying it to a suitable detector, usually a sensitive photomultiplier. This likely involves optical fibers and sometimes a lens system or both. The signal is displayed on and digitized by an oscilloscope that communicates to a laptop. Labview software analyses and saves the signal. A review

article and subsequent publications by the ORNL authors further document the method for a variety of situations.<sup>1</sup>

## Test Description

**Rail gun and armatures.** Four views of the rail gun selected are shown in Figure 1. The armature for this demonstration rail gun is shown in Figure 2. The top right hand armature, designated armature 1, was coated with a mixture of phosphor and a high temperature paint base used by the race car industry for its high temperature capability. It appears that some of the phosphor may have rubbed off. At least some of this is due to sanding down the coating prior to use in order to minimize the coating thickness. It was used in about forty of the shots fired by the rail gun over the two day period. The bottom four armatures in figure 2 were photographed in ultraviolet light and fluorescence is seen from the three coated ones. The digital camera depicts the ultraviolet light as deep purple as seen. The armature on the far left was not coated. The second armature from the left was used for several shots. The third from the left is armature 1. The remaining armature is phosphor coated but was not used.

**Laser and Optics.** A nitrogen laser was selected for this test since it can excite most phosphor materials considered useful for this application and emits many photons in a few nanoseconds. It is seen in figure 3 connected to a metal-sheathed dual fiber probe. One fiber delivers the laser light to the output end of the fiber (0.8 mm in diameter). Another fiber of the same size and situated next to it captures the fluorescence and conveys it to a photomultiplier tube (PMT) for detection. Figure 4 depicts the dual fiber probe inserted underneath the channel for viewing the bottom surface of the armature. The black-jacketed fiber also shown in this figure performed the time-of-arrival and velocity function. It is a type of 2 x 1 fiber splitter. Light from a red diode laser was injected into the input end. Light emerging from the output end illuminates the channel. When the armature moves into the beam, an increased amount of light is reflected back into the fiber and that signal is conveyed to a PMT (not shown). This signal provided a timing mark from which the laser trigger pulse was generated. The dual fiber was slightly down stream of the time-of-arrival fiber. So, a fifty or 100 microsecond delay between the timing mark and the laser trigger coincided with the armature being directly above the fluorescence-sensing dual fiber. A second 2 x 1 timing fiber was also available but was not, in the end, required.

A block diagram is shown in figure 5. One oscilloscope was dedicated to the timing signals and the other to capturing the fluorescence signal. The most time consuming activity related to triggering and timing, at first to gain understanding of the signals returned from the armature, and then to focus on illuminating a specific spot on the armature regardless of velocity variation.

**Data Acquisition System.** Each oscilloscope communicates via a National Instruments GPIB bus to a laptop computer. National Instruments Labview software captures the signals and analyzes the fluorescence signals. Figure 6 shows the user interface as seen by the operator. It shows a decay signal, negative as is characteristic of PMT signals. A panel in the middle enables the selection of phosphor which in this case is a deep green emission line

---

<sup>1</sup> Rev. Sci. Instrum. 68(7), pp. 1-36, July 1997

(514 nm) of  $\text{La}_2\text{O}_2\text{S:Eu}$ . The decay time, tau, is displayed. The temperature is determined from a calibration programmed into the code and displayed. If there are interfering effects from bright backgrounds, motion effects, or other concerns, the signal is post processed using a spreadsheet program (Sigma Plot or Excel, in practice) and then the corrected signal is returned to the labview program in order to ascertain temperature.

The phosphor chosen for this test has a high degree of temperature sensitivity but a limited range. It turned out to be the correct choice for this test. For future testing where temperatures and velocities will be higher, an alternate material may be required. This is discussed in the conclusions.

## Results

**Timing and Velocity Measurement.** Figure 7 shows two signals produced by the timing fiber. The blue trace is the signal from an armature and it is typical of most of the shots. There were no markings or alterations purposely made to the armature to affect the reflected light. The sharp rise is produced by the leading edge of the armature moving into the field of the timing fiber. There are some fluctuations of the signal as the surface moves along. Evidently this is due to superficial irregularities of the surface. The signal falls precipitously as it moves out of the field of view of the fiber. Table 1 below shows the results of velocity measurement for a number of shots.

In order to investigate another means for attaining well-defined timing and precise velocity measurement, two distinct grooves were purposely filed into an armature. It is the one seen in the inset photograph in figure 7. The black trace in the figure is the reflected signal from this armature. The two grooves produced pronounced dips in the reflected signal, the desired effect. This is therefore an effective optical encoding method. Clearly, with some more thought given to the optical illumination and to precision machining, this has the potential for larger scale rail gun implementation.

**Table 1 Shot velocity**

Shot #	Velocity m/s
37	60
38	76
39	67
41	67
42	21
43	51
44	53
45	72
46	76
47	80
48	88
49	19
51	28

**Temperature measurement.** Figure 8 shows the processed fluorescence signal for rail gun shots 42, 44, 47 and 48. Each of these signals was uploaded into the Labview program to get the temperature determination. It is seen that as the fluorescence duration, or lifetime, gets shorter, the temperature gets hotter. Table 2 shows the calculated temperature for these shots. Figure 9 is a plot of temperature and velocity versus shot number. Temperatures ranged from 22 to 92 °C. There are two different decay time algorithms that were used and they differed at most by 2 °C. That figure therefore is taken as the uncertainty in temperature measurement.

Table 2 Shot Temperature

Shot #	Temperature C
42	43
43	34
44	30
45	44
46	45
47	54
48	92
49	67

**Motion Correction.** A major concern is that the armature does move appreciably during the measurement period. It is seen in figure 8 that the measurement may require up to twenty microseconds. For example, an armature moving at 100 m/s would move 2 mm during the measurement. Thus, the light collected by a fiber from a source shining with constant intensity would change as it moves into and out of the acceptance cone of a fiber. Therefore, the received signal is due to two things changing, the time decay of the fluorescence and this motion effect. The motion effect was observed. The temperature-dependent emission line from phosphor used for this test, La<sub>2</sub>O<sub>2</sub>S:Eu, is blue-green (514 nm). A red emission line (620 nm) from the same phosphor has a very long decay time and it is independent of temperature up to around 100 °C. Thus by comparing a stationary signal from this red emission line to one that is moving, the collected signal versus time for motion can be determined. The temperature-dependent data can therefore be corrected with that function. It turned out that correction for the motion effect resulted in only a two degree change in the temperature determination for shot 44. It was expected that the effect would be most pronounced for shot 44 since it was of the longest duration. Figure 9 is the ratio of the stationary to moving signal from the temperature independent emission line of the phosphor. The velocity for the moving signal was 67 m/s. To correct shot 44, this had to be time scaled according to the 53 m/s speed of that shot. This is also depicted. Next the acquired signal from shot 44 is normalized by this correction factor. Owing in part to the high temperature sensitivity of this material, the motion had little effect on the results.

## **Discussion**

Temperature and velocity measurement based on optical methods was demonstrated. Fiber insertion and electronic timing issues were solved. Fluorescence signals were strong. There was no electromagnetic interference observed. The most critical issue is the movement of the fluorescing spot on the armature which can move into and out of the field-of-view of the light receiving fiber so that the signal is a combination of this and the exponential decay. Even with a variation of up to 40%, the deviation in decay time was fairly small. For future applications, however, speeds may be an order of magnitude faster. The following several observations are pertinent to this and provide assurance that the method will function well at 500 m/s and higher.

1. It was shown that for a speed of about 50 m/s and a decay time of about 10 microseconds, the motion correction procedure described above was effective. This should scale such that for speeds an order of magnitude faster, about 500 m/s, then a phosphor with a decay time of 1 microsecond or less would also be effective. There are several good candidate phosphors which could serve this purpose. Some are shown in figure 10. Generally, cerium (Ce) doped phosphors have decay times less than 100 ns. Praesodymium (Pr) doped phosphor decay times are fairly short, starting out at a few microseconds at the lowest temperatures. One example is shown in the figure but there are other hosts as well that should be able to operate at higher temperatures. Lastly, thullium (Tm) phosphors may also be effective.
2. One way to flatten the effect of motion is to back the fiber a distance from the fluorescing spot. This sacrifices some signal as the source is further away but reduces the field of view.
3. Where possible to implement, a linear array of collection fibers would lengthen the collection region and increase the time that signal is in the field of view.
4. Another method to extract temperature from fluorescence signals is to ratio two different emission lines. This was in principle demonstrated in the present test in that both the 514 nm (temperature dependent) and 538 nm (temperature independent) emission lines were sequentially detected. By adding a fiberoptic beam splitter and an additional PMT detector, it will be possible to acquire and ratio these two emission lines simultaneously. In such an instance, motion may affect the overall signal strength versus time of the two signals. However, the wavelength ratio will not change in time unless there is heating or cooling occurring on that time scale.

## **Suggestions for Further Development**

The near term goal is to conduct the next test on a bench scale rail gun at the IAT facility. This will involve:

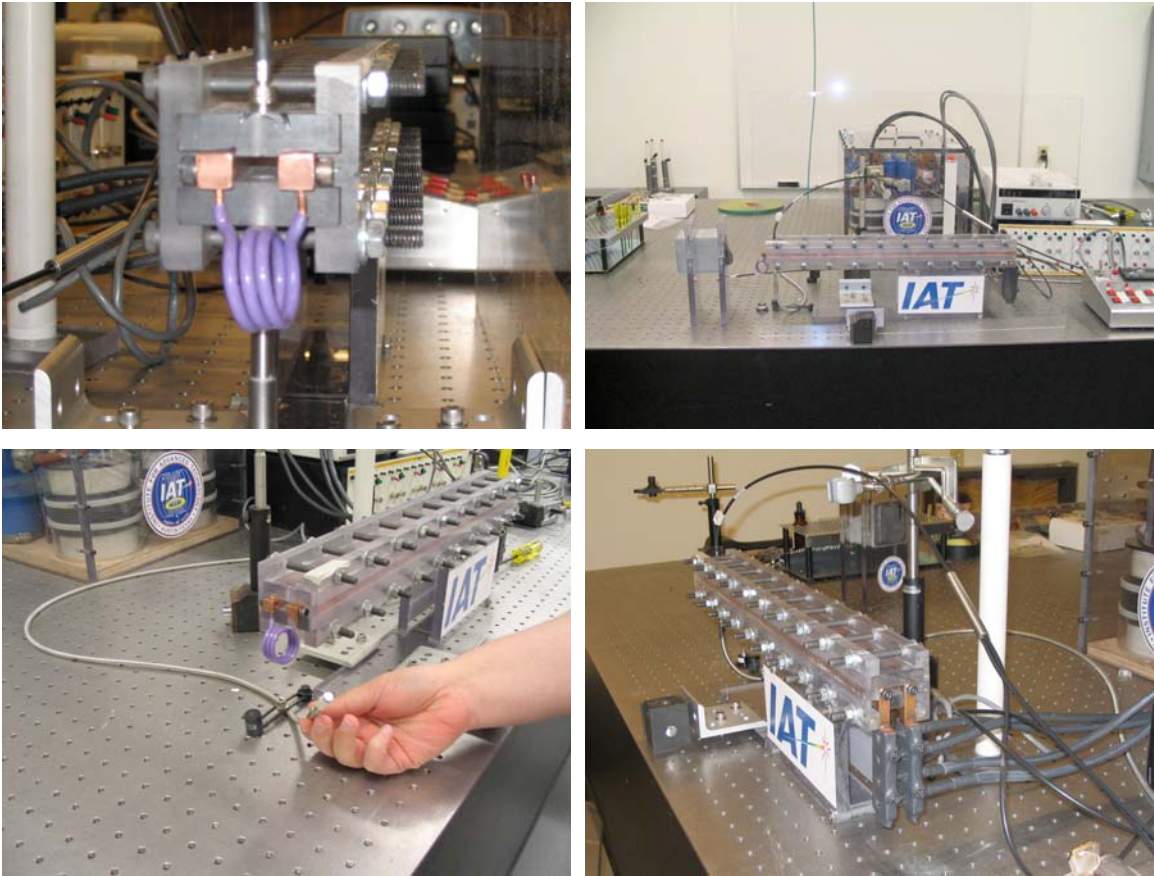
1. Continuing the groove/etch approach for velocity measurement. Velocities will be about 500 m/s.
2. Adding a fiber splitter to the fluorescence sensor so as to be able to monitor two wavelengths on each shot. This will allow for velocity correction of each shot.

Other developments are necessary to maximize the usefulness of this instrumentation. The Labview code should be modified to automatically make the velocity correction. With regard to timing and velocity measurement greater attention to fiber design will be necessary in order to accommodate the scale model rail guns. The reflected signal characteristics will depend on such parameters as the fiber numerical aperture, distance from armature path, fiber diameter, and number of fibers.

### Conclusions

Using a demonstration railgun provided by IAT and operated by IAT, both velocity and temperature of an armature have been measured using light. A red diode laser was used to measure velocity of the armature in two ways, and an ultraviolet-pulsed laser was used to measure the temperature of the armature at very nearly the same time as the velocity measurement. In making these measurements a way has been visualized to scale the techniques to much faster armatures in guns located in IAT laboratories.

All of the authors wish to thank the manager of the United States Army Electromagnetic Gun Program, Mr Matt Cilli, for funding this activity.



**Figure 1. Four views of rail gun demonstrator. Upper left shows the output end. Upper right shows side view. Lower right shows input end. Lower left shows the output end of the rail gun and dual fiber probe for fluorescence excitation and collection.**





**Figure 2. Armatures. Upper photo made in room light. Bottom photo made with ultraviolet illumination to produce fluorescence from the three right hand projectiles.**

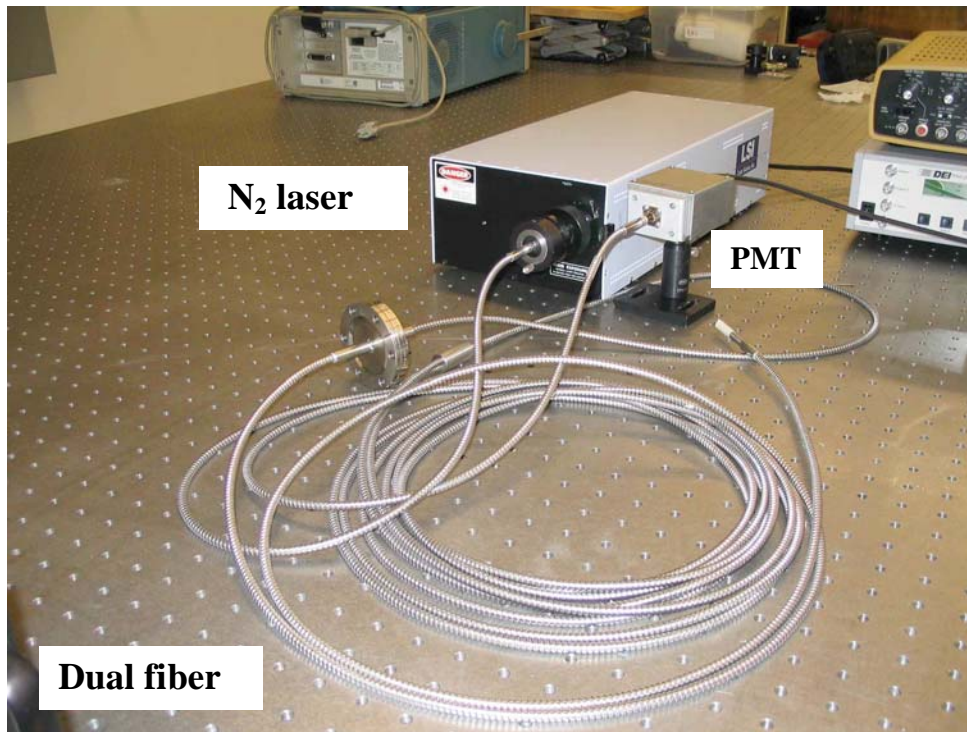


Figure 3. Laser, dual fiber with metal sheath, and detector (PMT).

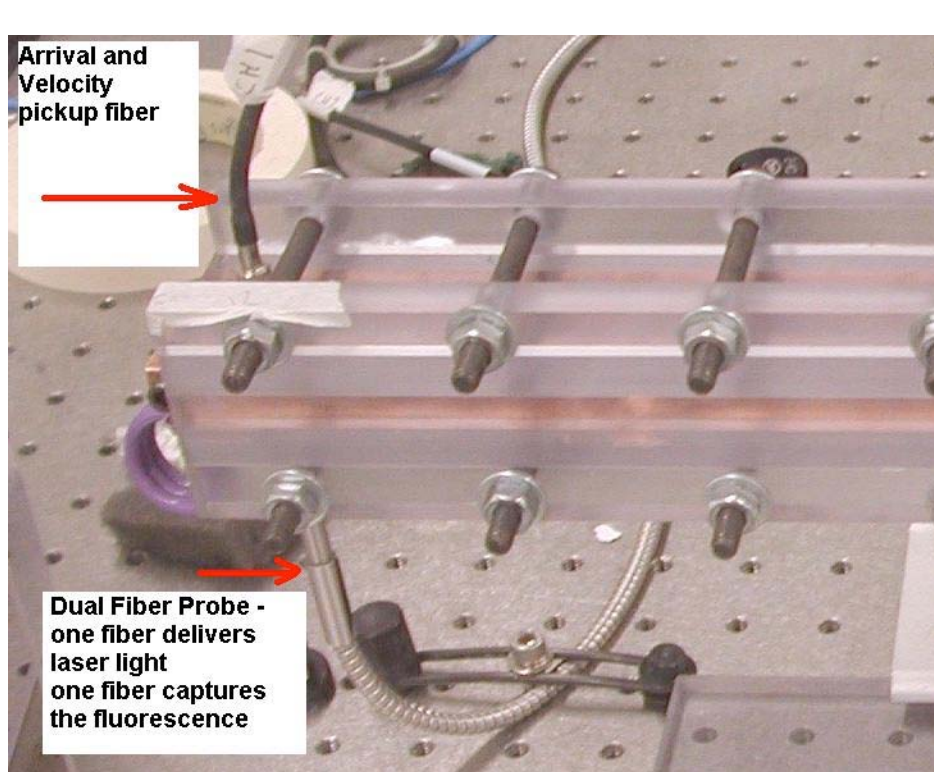
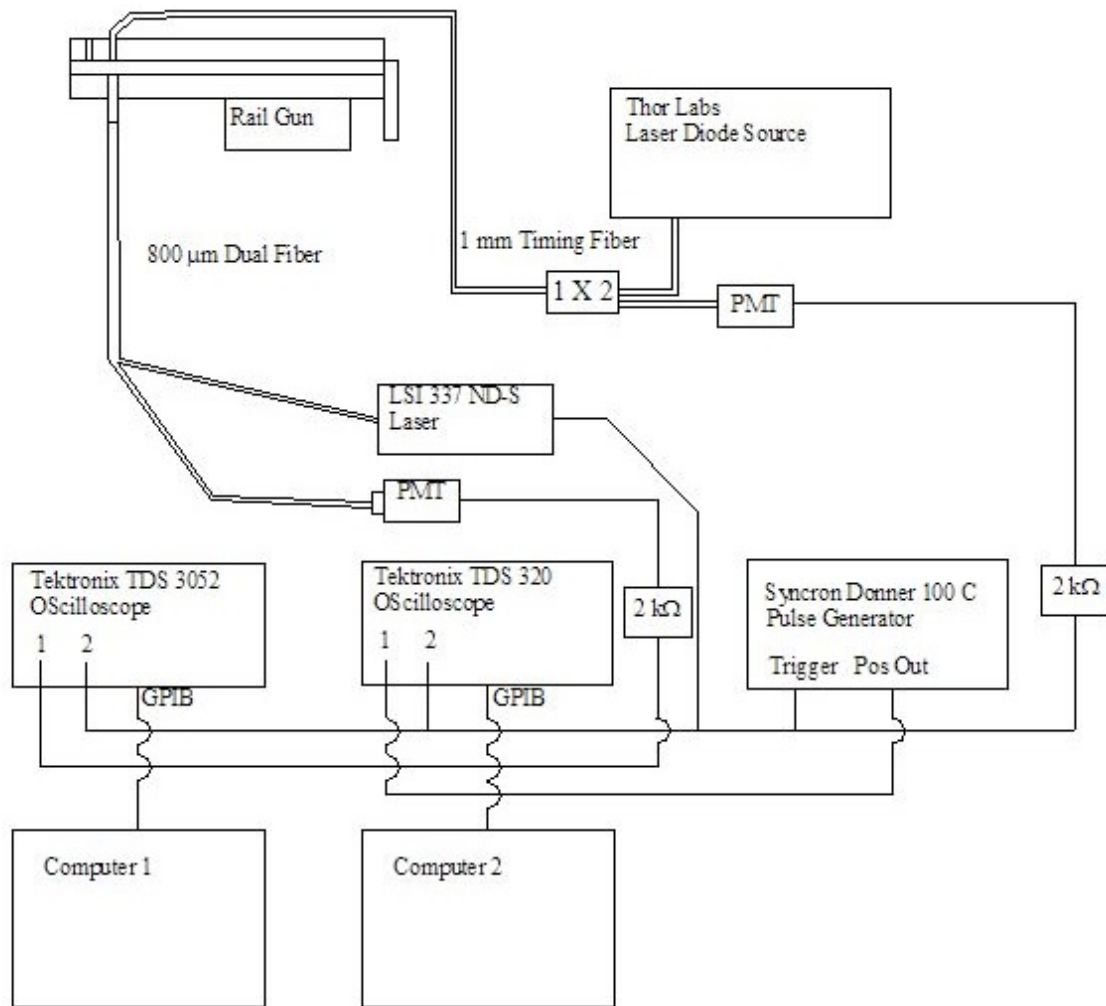


Figure 4. Side view of output end of rail gun. The dual fiber probe views the channel from the bottom. The velocity pickup fiber is situated on top.



**Figure 5. Test Setup Block Diagram.**

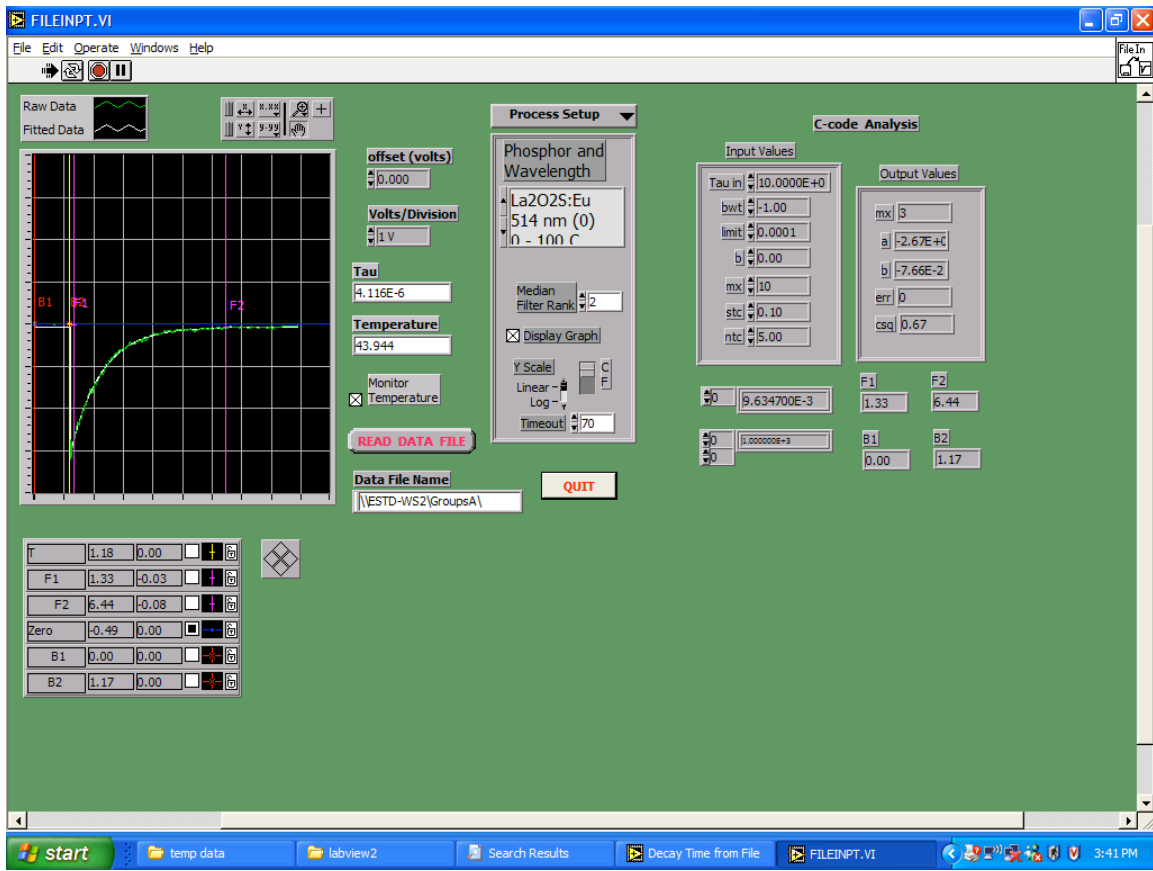


Figure 6. Labview User Interface.

### Velocity Timing Signal

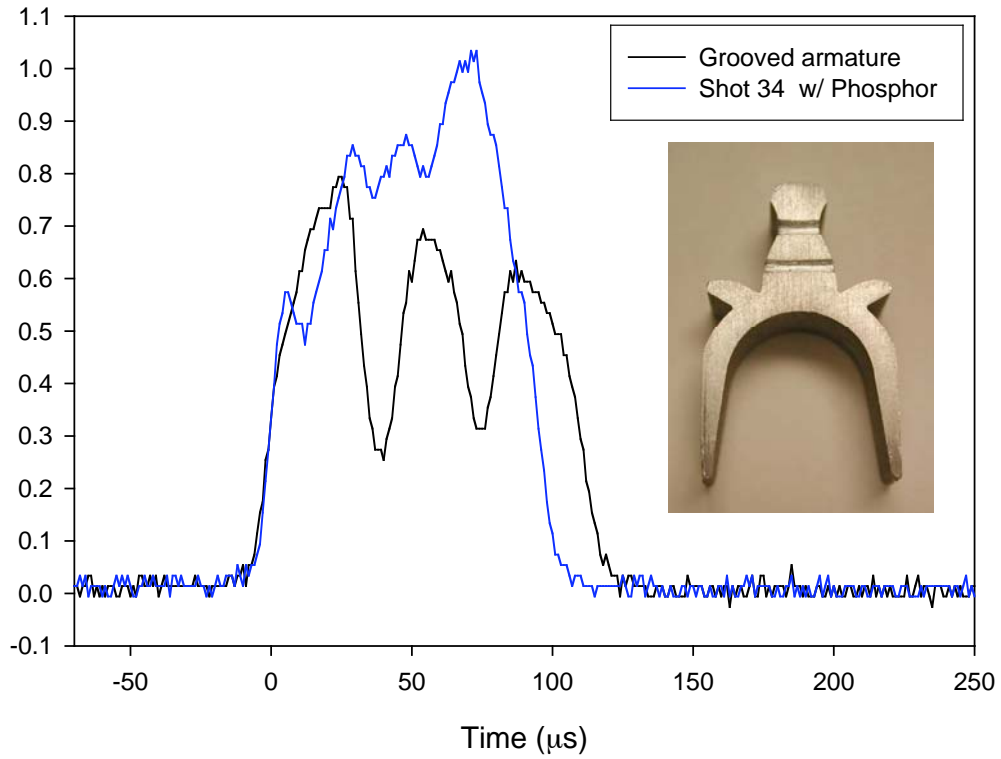


Figure 7. Velocity Signals.

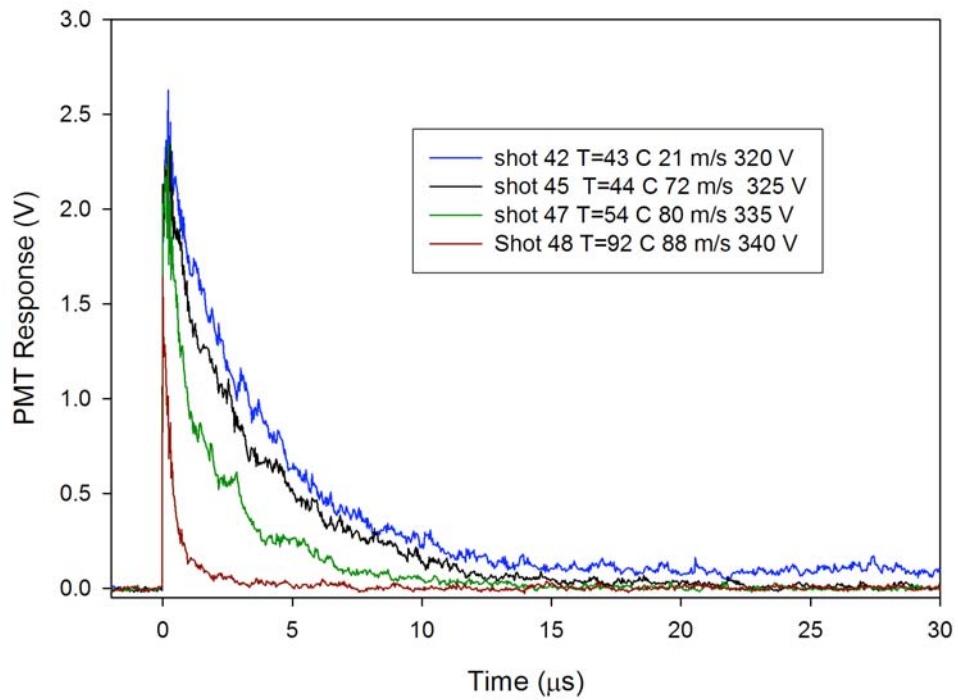
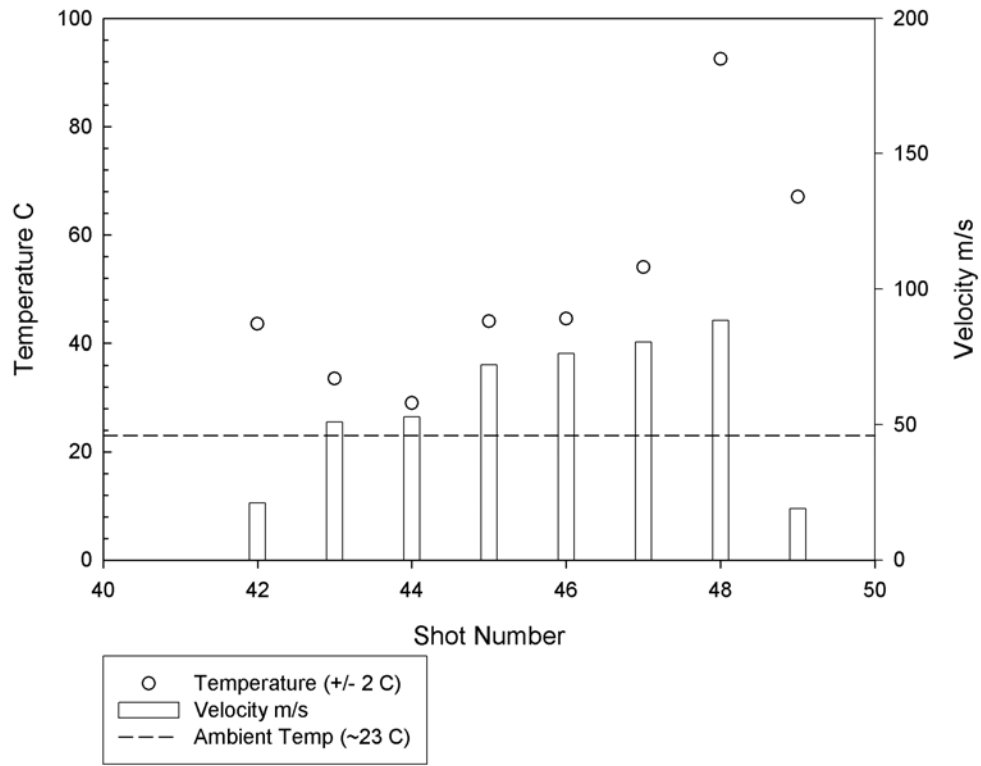


Figure 8. Fluorescence signals for several shots, uncorrected for motion.

### Temperature versus Shot Number



**Figure 9. Temperature and Velocity versus Shot #.**

### Response of $\text{La}_2\text{O}_2\text{S}:\text{Eu}$ at 620 nm in Motion

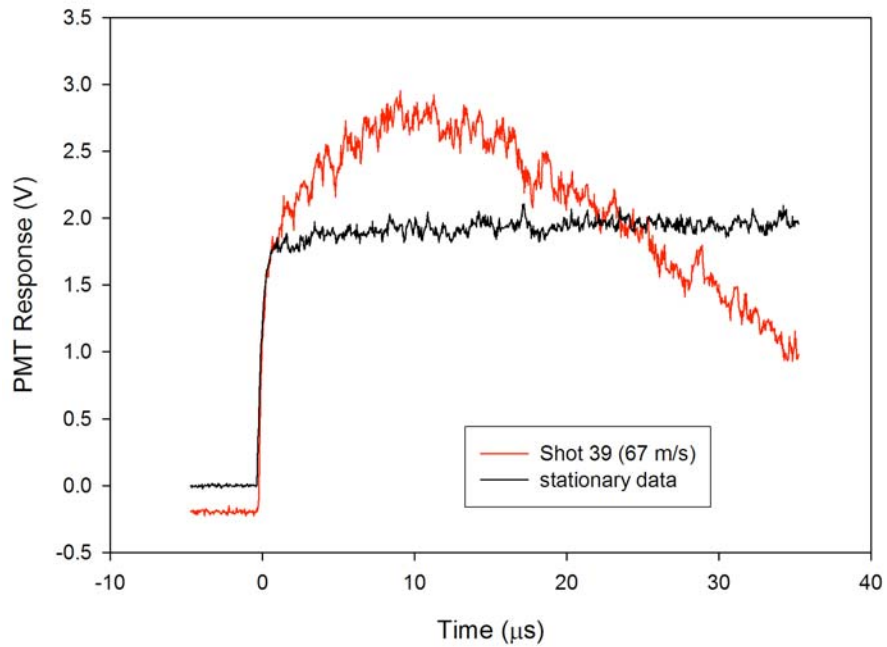


Figure 10. Motion effect, long-lived temperature independent emission line at 620 nm.

### Motion Correction Factor

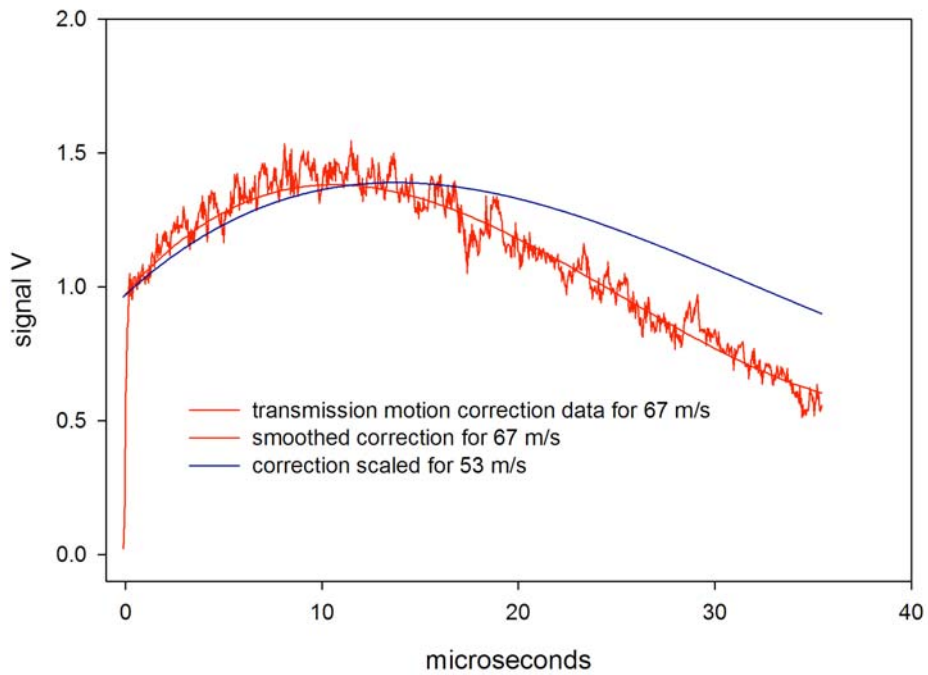
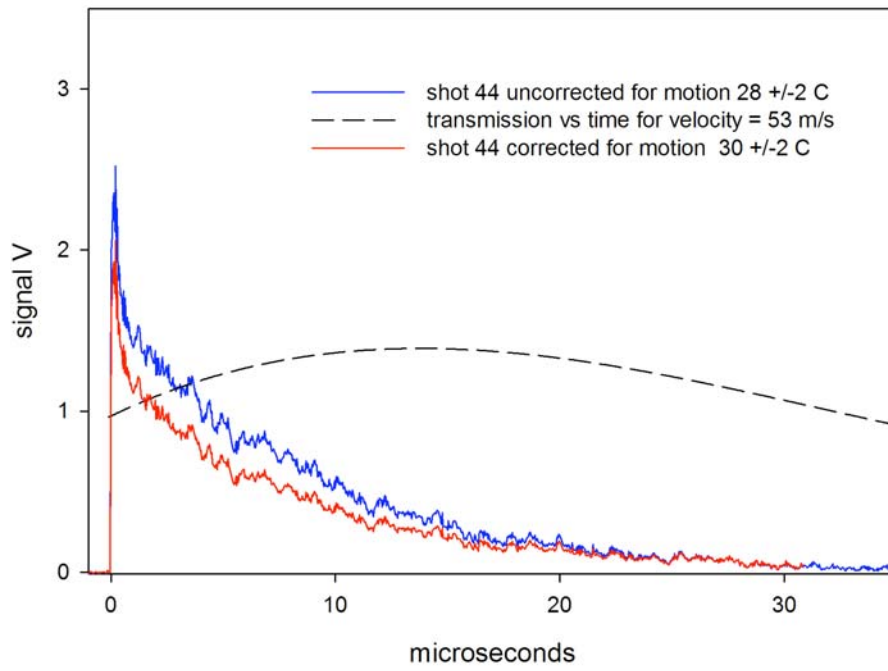


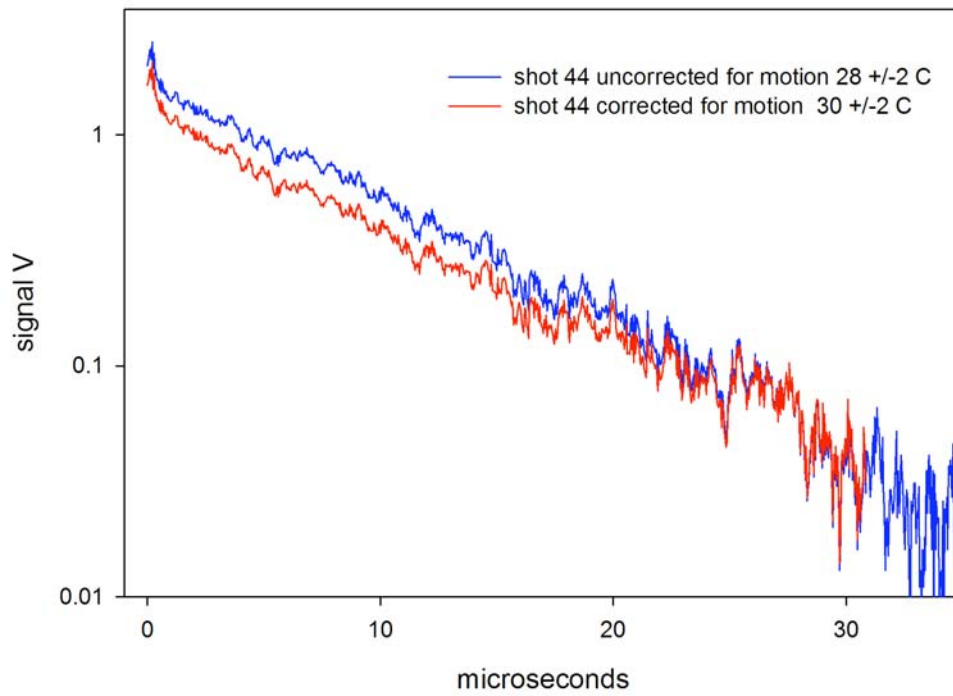
Figure 11. Motion correction factor obtained by ratio of moving to stationary waveforms for 538 nm emission line.



## Effect of Motion

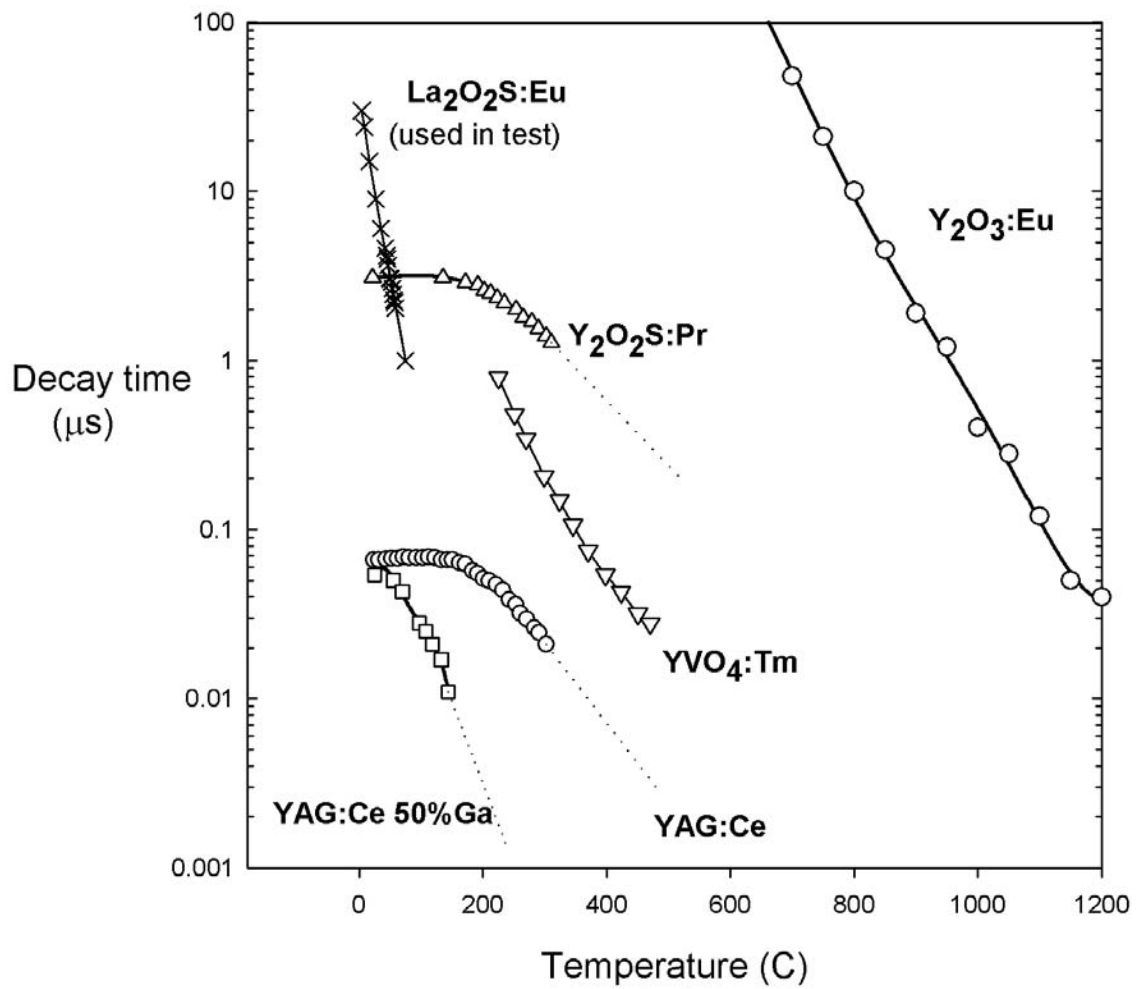


**Figure 12. Shot 44 signal with and without motion correction.**



**Figure 13. Logarithmic plot of shot 44 corrected and uncorrected.**





**Figure 14.** Some representative phosphor temperature dependence curves emphasizing short decay times.