

EBIS preinjector construction status

**J. Alessi, D. Barton, E. Beebe, S. Bellavia, O. Gould,
A. Kponou, R. Lambiase, E. Lessard, R. Lockey, V. LoDestro,
M. Mapes, D. McCafferty, A. McNerney, M. Okamura,
A. Pendzick, D. Phillips, A. Pikin, D. Raparia, J. Ritter,
J. Scaduto, L. Snyderstrup, M. Wilinski, A. Zaltsman
Brookhaven National Laboratory, Upton, N.Y. 11973**

**U. Ratzinger, A. Schempp
IAP, Frankfurt, Germany**

Submitted to the XXIV Linear Accelerator Conference (LINAC08)
Victoria, British Columbia, Canada
September 29 – October 3, 2008

Collider-Accelerator Department

Brookhaven National Laboratory

P.O. Box 5000
Upton, NY 11973-5000
www.bnl.gov

Notice: This manuscript has been authored by employees of Brookhaven Science Associates, LLC under Contract No. DE-AC02-98CH10886 with the U.S. Department of Energy. The publisher by accepting the manuscript for publication acknowledges that the United States Government retains a non-exclusive, paid-up, irrevocable, world-wide license to publish or reproduce the published form of this manuscript, or allow others to do so, for United States Government purposes.

This preprint is intended for publication in a journal or proceedings. Since changes may be made before publication, it may not be cited or reproduced without the author's permission.

DISCLAIMER

This report was prepared as an account of work sponsored by an agency of the United States Government. Neither the United States Government nor any agency thereof, nor any of their employees, nor any of their contractors, subcontractors, or their employees, makes any warranty, express or implied, or assumes any legal liability or responsibility for the accuracy, completeness, or any third party's use or the results of such use of any information, apparatus, product, or process disclosed, or represents that its use would not infringe privately owned rights. Reference herein to any specific commercial product, process, or service by trade name, trademark, manufacturer, or otherwise, does not necessarily constitute or imply its endorsement, recommendation, or favoring by the United States Government or any agency thereof or its contractors or subcontractors. The views and opinions of authors expressed herein do not necessarily state or reflect those of the United States Government or any agency thereof.



EBIS PREINJECTOR CONSTRUCTION STATUS*

J. Alessi[#], D. Barton, E. Beebe, S. Bellavia, O. Gould, A. Kponou, R. Lambiase, E. Lessard, R. Lockey, V. LoDestro, M. Mapes, D. McCafferty, A. McNerney, M. Okamura, A. Pendzick, D. Phillips, A.I. Pikin, D. Raparia, J. Ritter, J. Scaduto, L. Snydstrup, M. Wilinski, A. Zaltsman, BNL, Upton, Long Island, New York
U. Ratzinger, A. Schempp, IAP, Frankfurt am Main

Abstract

A new heavy ion preinjector is presently under construction at Brookhaven National Laboratory. This preinjector uses an Electron Beam Ion Source (EBIS), and an RFQ and IH Linac, both operating at 100.625 MHz, to produce 2 MeV/u ions of any species for use, after further acceleration, at the Relativistic Heavy Ion Collider, and the NASA Space Radiation Laboratory. Among the increased capabilities provided by this preinjector are the ability to produce ions of any species, and the ability to switch between multiple species in 1 second, to simultaneously meet the needs of both physics programs. Fabrication of all major components for this preinjector is in process, with testing of the EBIS and RFQ starting this year. The status of this construction is presented.

ion sources able to inject pulses of 1+ ions into the EBIS trap, species from EBIS can be changed on a pulse-to-pulse basis. The switching time for the magnets in the HEBT line will be 1 second. Some key parameters are given in Table 1. More details on the EBIS source and preinjector can be found in [1] and [2].

Table 1: Preinjector Parameters

Ions	He - U
Q / m	$\geq 1/6$
Current	> 1.5 emA
Pulse length	10 μ s (for 1-turn injection)
Rep rate	5 Hz
Output energy	2 MeV / u
Time to switch species	1 second

INTRODUCTION

The layout for the new EBIS-based heavy ion preinjector is shown in Fig. 1. This preinjector, will be located at the high energy end of the existing 200 MeV H-linac building. Not shown in this figure is an additional 37 m long beamline which connects the preinjector to the heavy ion injection point of the Booster Synchrotron. This preinjector will replace two existing Tandem Van de Graaff accelerator and an 800 m transport line, as the heavy ion preinjector for both the Relativistic Heavy Ion Collider (RHIC) and NASA Space Radiation Laboratory (NSRL). It is designed to deliver milliampere currents of any ion species in short pulses, to allow single-turn injection into the Booster. With any of several external

EBIS SOURCE

The design of the EBIS source is based on the very successful performance of the prototype Test EBIS at Brookhaven [1]. The primary changes in the present EBIS, relative to the prototype, is the increase of the source trap length from 0.7 to 1.5 m, which requires a superconducting solenoid with a length of 2m. Other changes relative to the Test EBIS are intended to allow operation at higher repetition rates, and improve reliability and maintainability. The source is shown schematically in Fig. 2. A brief status of some of the key components follows.

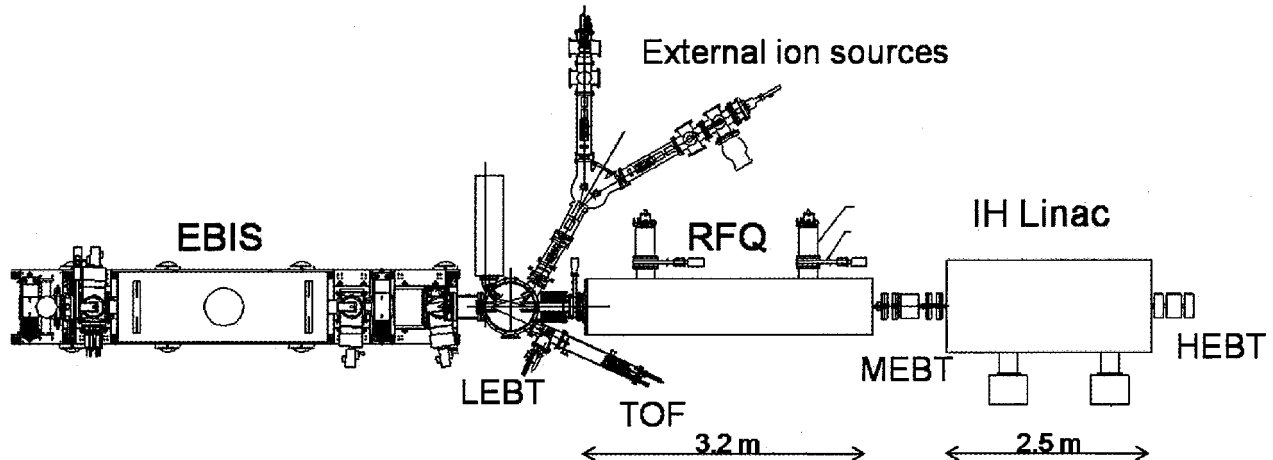

Figure 1: Layout of the EBIS-based heavy ion preinjector

*Work supported under the auspices of the US Department of Energy and the National Aeronautics and Space Administration.

[#]alessi@bnl.gov

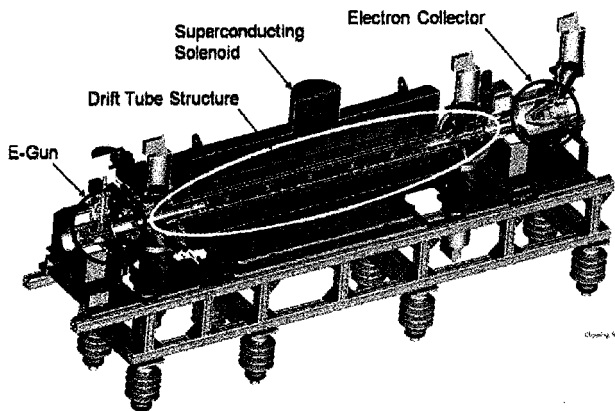

Figure 2: Drawing of the new RHIC EBIS

Electron Gun

The EBIS is planned to operate with a 10 A electron beam, but the electron gun is designed for up to 20 A operation. The cathode is a 9.2 mm diameter IrCe unit, made for BNL by BINP [3]. The electron gun has been fabricated, and successfully tested to 10 A on the Test EBIS.

Electron Collector

The electron collector is designed to handle a nominal electron beam of 20 A, 15 kV dc, i.e. 300 kW, but since ionization times are typically < 50 ms, the electron beam can be pulsed at a duty factor $< 25\%$, allowing the collector to handle lower average power. A collector fabricated from a Zr-Cr-Cu alloy in the Brookhaven shops, has been completed and is being installed on the Test EBIS for initial testing. A second collector is being made from a high conductivity Be-Cu (Hycon 3 HP). This should have somewhat better thermal fatigue lifetime. This collector is being fabricated by Brush-Wellman, and after some difficulties during the welding of the material, is now nearly complete as well.

Superconducting Solenoid

The superconducting solenoid for the EBIS is 2 m long, and will have a 5.5 T field which is uniform to within $\pm 0.25\%$ over the 1.5 m trap length. The solenoid has a 204 mm diameter warm bore, to allow sufficient space for the vacuum pipe, which also has heating rods and water cooled shield for baking of the central trap region. The solenoid is being fabricated by ACCEL Instruments [4]. A failure during a quench test last year has delayed the delivery, but the magnet is now again ready for final acceptance testing.

Central Trap

The central trap region consists of six cylindrical electrodes of ~ 42 mm diameter, each electrode capable of being individually biased. There is also NEG material running the length of the central vacuum pipe to provide extra pumping in this region. This assembly has been completed, and is being prepared for assembly on the RHIC EBIS.

RFQ

The final design and fabrication of the RFQ was done through the Institute of Applied Physics at the University of Frankfurt, with most of the fabrication by NTG [5]. Some RFQ parameters are given in Table 2. Following vacuum testing and field measurement, the RFQ is now in transit to Brookhaven for initial testing with beam from the Test EBIS. More details on the RFQ can be found in [6]. The RFQ is shown during assembly in Fig. 3.

Table 2: Parameters of the RFQ

Input Energy	17 keV/u
Output energy	300 keV/u
Q / m	$> 1 / 6$
Frequency	100.625 MHz
Length	3.2 m
Power (with beam loading)	~ 200 kW

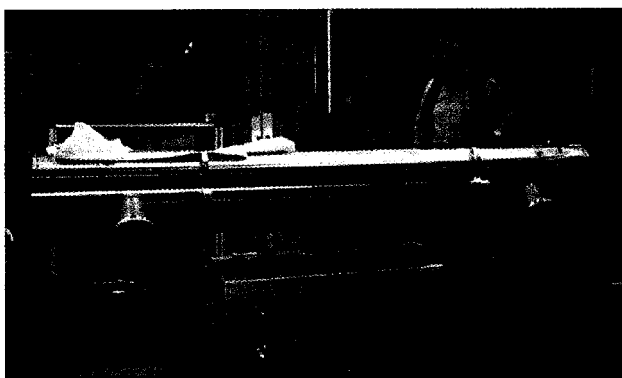

Figure 3: RFQ during assembly at IAP

IH LINAC

As with the RFQ, the final design and fabrication of the IH Linac is also being done through IAP, Frankfurt. The linac is designed for a beam current of up to 10 mA. The detailed design is completed, and fabrication of the cavity has started at PINK [7]. The internal quadrupole triplet will be built by Bruker [8]. The schematic of the linac is shown in Fig. 4, and parameters for the linac are given in Table 3. The cavity has ~ 5 cm thick walls, in order to reduce x-ray levels external to the linac. The linac is scheduled for delivery in the summer of 2009.

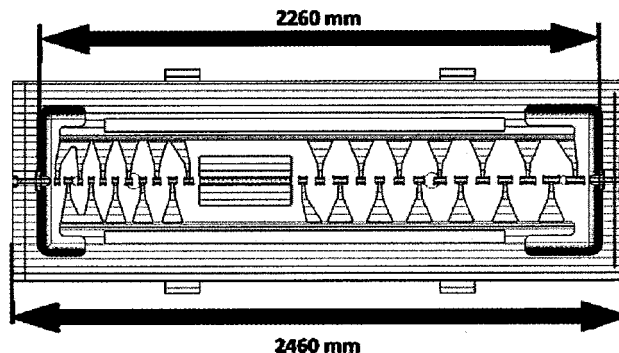

Figure 4: Schematic of the IH linac

Table 3: Parameters of the IH Linac

Input energy	300 keV/u
Output energy	2 MeV/u
Q / m	> 1 / 6
Frequency	100.625
Cavity Length	2.46 m
Power (with beam loading)	~ 300 kW

BUNCHER CAVITIES

There are three spiral resonator cavities being built by IAP for the preinjector. A 20 cm long 4-gap rebuncher cavity will sit between the RFQ and linac. This cavity is presently being fabricated from Al, since it is very low power and low duty factor. In the HEBT line, there is a 4-gap debuncher cavity ~12 m from the end of the linac, and a 2-gap debuncher ~ 26 m from the end of the linac, to reduce the energy spread of the beam going into the Booster.

RF AMPLIFIERS

The rf amplifiers for the RFQ and linac have been manufactured by Continental Electronics [9]. Each unit combines power from two 175 kW amplifiers which use a TH535 tetrode at the final stage, to produce 350 kW peak power at 100.625 MHz. These amplifiers were delivered to Brookhaven in August, and are now being installed in their final location.

HEBT

The High Energy Beam Transport (HEBT) line transports the beam from the linac to Booster injection. There is a ~17 m section in the linac building, and then the beamline passes through a ~8 m thick shield wall and in to the Booster tunnel. Inside the Booster, there is ~12 m transport, including two dipoles, to inject beam into the Booster at the same location as beam coming from the Tandems. The final section of HEBT is shown in Fig. 5.

The two identical dipoles are laminated magnets to allow the required 1 second field changes. The magnets each have a bend angle of 72.5 degrees, a 13.5 cm gap, 1.3m bend radius, and 1T maximum field [10]. These magnets were manufactured by Sigmaphi [11], and were delivered on schedule in July, 2008.

The boring through the shield wall, and installation of the beampipe, occurred during the summer of 2007. During the summer of 2008, the dipoles were installed in the Booster tunnel (Fig. 6), and the remainder of the Booster-side beamline has been installed and is under vacuum.

SUMMARY

There has been considerable progress in many areas in addition to those mentioned above. Hardware for LEBT and external ion injection is being fabricated. All power supplies for operation of the EBIS and LEBT line are now

in hand and are being installed. Most hardware for the control system, vacuum, and beam diagnostics has been procured. The commissioning of beam into the HEBT and Booster is presently scheduled to start in January, 2010.

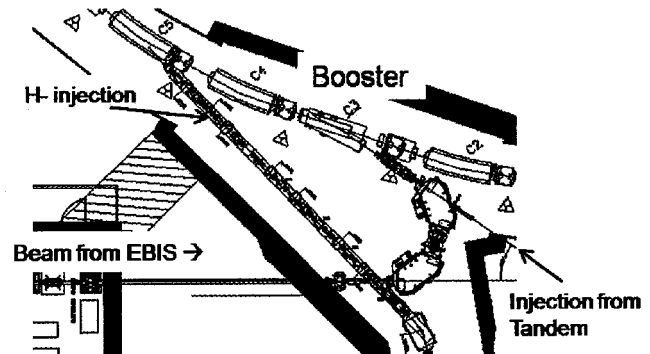

Figure 5: EBIS injection line into Booster



Figure 6: Dipoles installed in the Booster tunnel

REFERENCES

- [1] J. Alessi, E.Beebe, O.Gould, A.Kponou, R.Lockey, A.Pikin, D.Raparia, J.Ritter, L.Snydstrup, "High performance EBIS for RHIC", PAC 2007, Albuquerque, p. 3782 (2007)..
- [2] J. Alessi, et.al., "Status of the EBIS project at Brookhaven", Linac 2006, Knoxville, p. 365 (2006).
- [3] G. Kuznetsov, Nuclear Instrum. & Meth. In Physics Res. A 340, 1994, p. 204.
- [4] ACCEL Instruments GmbH, Bergisch Gladbach, Germany.
- [5] NTG GmbH, Gelnhausen, Germany.
- [6] M.Vossberg, B.Hofmann, A.Schempp, J.Alessi, D.Raparia, L.Snydstrup, "RF tuning of the EBIS-RFQ", these Proceedings.
- [7] PiNK GmbH, Wertheim, Germany.
- [8] Bruker Biospin S.A., Wissenbourg, France.
- [9] Continental Electronics Corp., Dallas, TX.
- [10] T.Kanesue, D.Raparia, J.Ritter, M.Okamura, J.Tamura, "Design study of the dipole magnet for the RHIC EBIS high energy transport line", PAC 2007, Albuquerque, p. 3301 (2007).
- [11] Sigmaphi, Vannes, France.