



BNL-81639-2008-CP

***Research and Development Program on Beam
Position Monitors for NSLS-II Project***

*Igor Pinayev, O. Singh, R. Alforque, A. Blednykh,
P. Cameron, V. Ravindranath, S. Sharma*

*Presented at the 11th European Particle Accelerator Conference (EPAC '08)
Genoa, Italy
June 23-27, 2008*

July 2008

National Synchrotron Light Source II

Brookhaven National Laboratory

P.O. Box 5000
Upton, NY 11973-5000
www.bnl.gov

Notice: This manuscript has been authored by employees of Brookhaven Science Associates, LLC under Contract No. DE-AC02-98CH10886 with the U.S. Department of Energy. The publisher by accepting the manuscript for publication acknowledges that the United States Government retains a non-exclusive, paid-up, irrevocable, world-wide license to publish or reproduce the published form of this manuscript, or allow others to do so, for United States Government purposes.

This preprint is intended for publication in a journal or proceedings. Since changes may be made before publication, it may not be cited or reproduced without the author's permission.

DISCLAIMER

This report was prepared as an account of work sponsored by an agency of the United States Government. Neither the United States Government nor any agency thereof, nor any of their employees, nor any of their contractors, subcontractors, or their employees, makes any warranty, express or implied, or assumes any legal liability or responsibility for the accuracy, completeness, or any third party's use or the results of such use of any information, apparatus, product, or process disclosed, or represents that its use would not infringe privately owned rights. Reference herein to any specific commercial product, process, or service by trade name, trademark, manufacturer, or otherwise, does not necessarily constitute or imply its endorsement, recommendation, or favoring by the United States Government or any agency thereof or its contractors or subcontractors. The views and opinions of authors expressed herein do not necessarily state or reflect those of the United States Government or any agency thereof.

RESEARCH AND DEVELOPMENT PROGRAM ON BEAM POSITION MONITORS FOR NSLS-II PROJECT*

I. Pinayev[#], O. Singh, R. Alforque, A. Blednykh, P. Cameron, V. Ravindranath, S. Sharma, BNL, Upton, NY 11793, U.S.A.

Abstract

The NSLS-II Light Source, which is planned to be built at Brookhaven National Laboratory, is designed for horizontal emittances below 1 nm and will provide users with ultra-bright synchrotron radiation sources. In order to utilize fully the very small emittances and electron beam sizes, submicron stability of the electron orbit in the storage ring needs to be provided. This can only be achieved with high stability beam position monitors (BPM). The research program presently carried is aimed for characterization of commercially available RF BPM receivers and on the development of high stability mechanical supports for BPM modules. The details of the program and preliminary results are presented.

INTRODUCTION

The NSLS-II storage ring has DBA lattice with 30 cells [1]. Each cell has six regular BPMs (two per girder), which are accompanied by two insertion device BPMs (ID BPM) installed in the straights with undulators or wigglers.

Due to ultra-small emittances the requirements on the orbit stability and, hence, accuracy of beam position accuracy are very tight. We want also to employ the BPM receivers with turn-by-turn capabilities. Such an approach will simplify commissioning of the storage ring and provide invaluable tools for accelerator studies and optimization.

Research on stability includes the evaluation of BPM receivers' noise and drifts and the development of ultra-stable support for ID BPMs.

Among other developments we need to mention optimization of BPM geometry on the following parameters: signal level, button heating, and sensitivity to beam position. Rogue modes in the vacuum chamber, which can affect RF BPM reading, will be also studied.

STANDARD RF BPMs

Geometry optimization

Table 1 gives a comprehensive position measurement resolution requirement within several time scales and intensity levels for standard BPM. The requirements for 100 mA to 500 mA are further subdivided, based on electronics and mechanical effects, so that there is a budget for each kind of effect. To achieve the highest level of orbit measurement resolution, the optimization of the button geometry is in progress [2]. The four high-

precision pick-up electrodes will be mounted on elliptical or small-gap chambers with optimized button diameter size and geometry locations. Although, the vertical separation of buttons is pretty much defined by chamber vertical apertures, the horizontal separation of buttons will be optimized to obtain a high level of BPM resolution. The analysis was done using a MATLAB script based on approach described in [3].

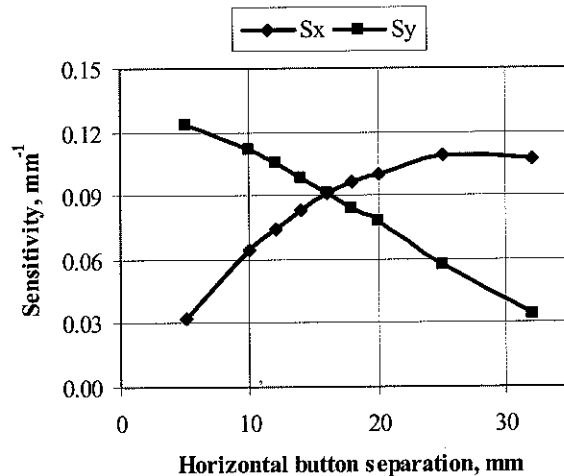

Figure 1: Dependence of BPM sensitivity to beam vs. horizontal button separation.

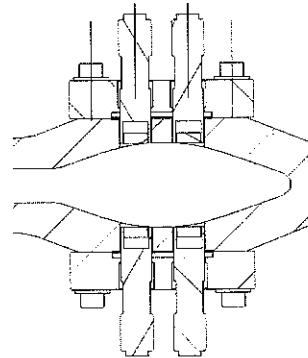

Figure 2: Custom flange with two BPM buttons installed. The mounting bolts are placed along the edge, where vacuum chamber has maximal thickness.

The baseline design with 32 mm horizontal separation can be achieved by using a commercially available 34-mm flange, but in result the vertical sensitivity is small (0.034 mm^{-1}). As horizontal separation is reduced to 10 mm, vertical sensitivity improves three fold; however to achieve this separation, either BPM buttons mounted on 34 mm flanges have to be mounted longitudinally or on a custom flange, housing two small diameter buttons, which

*Work supported by the U.S. Department of Energy with Contract No. DE-AC02-98CH10886

[#]pinayev@bnl.gov

Table 1: Position Measurement Resolution Requirements

Parameters/Subsystems			Conditions	Standard BPM System Requirements	
				Vertical	Horizontal
Single bunch, single turn resolution (@378 kHz)			0.05 nC charge	500 μm rms	500 μm rms
			5.0 nC charge	20 μm rms	20 μm rms
Single bunch, stored beam resolution (0.017-200 Hz BW)			0.02 mA	10 μm rms	10 μm rms
			2.0 mA	1 μm rms	1 μm rms
100-500 mA stored beam resolution, 20-100% duty cycle	BPM receiver electronics	Assuming no contribution from bunch charge/fill pattern	0.017-200 Hz	0.2 μm rms	0.3 μm rms
			200-2000 Hz	0.4 μm rms	0.6 μm rms
			1 min to 8 hr	0.2 μm pk-pk	0.5 μm pk-pk
		Bunch charge/fill pattern effects only	DC-2000 Hz	0.2 μm rms	0.3 μm rms
	Mechanical motion limit at pick-up electrodes assembly (ground and support combined)	Vibrations	50-2000 Hz	10 nm rms	10 nm rms
			4-50 Hz	25 nm rms	25 nm rms
0.5-4 Hz			200 nm rms	200 nm rms	
	Thermal	1 min to 8 hr	200 nm rms	500 nm rms	

needs to be developed. Fig. 2 shows a custom flange with two 7-mm buttons installed. 14-18 mm of horizontal separation, may be an acceptable solution with two-fold improvement in vertical sensitivity. Other effects such as linearity and operational range will be further explored.

Power level estimation

The data from same MATLAB script were also used for estimation of the power level from the BPM button. It was found that for 10-mm button signal, induced by 500 mA electron beam, has -2.1 dBm level and -8.4 dBm for 7-mm button. Moving beam trajectory from the center of vacuum chamber can increase signal level at least on one button, therefore provision should be need not to overload individual channel of a receiver.

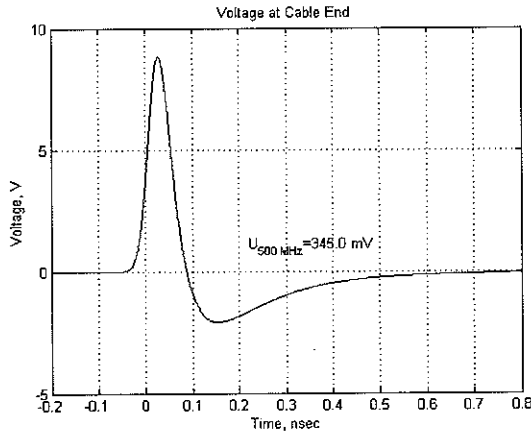

Figure 3: Profile of the button signal after 30 meters of RG-58 cable. Peak voltage is in safe limits for BPM receiver. The accuracy of modeling was verified on NSLS VUV storage ring.

Presently, we are considering utilizing 7-mm buttons for the following reasons:

- they simplify design of the custom flange with two buttons,
- there will be less problems with button heating by circulating beam current,
- the signal levels stays in the range of optimal performance of BPM receivers.

Using the value of charge fraction intercepted by a button the induced voltage was also estimated in the manner described in [4]. The results of modeling for 10-mm button are shown in Fig. 2.

Rotated button geometry

We investigated the applicability of rotated button geometry, when two buttons are shifted longitudinally along the vacuum chamber [5].

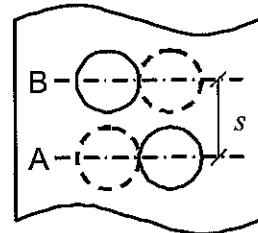

Figure 4: Location of BPM buttons with rotated geometry.

It was found that the geometry has small but not negligible systematic error due to coupling between vertical and horizontal planes:

$$\delta x, y = s \cdot \frac{S_{x,y}}{S_{y,x}} \alpha_{y,x} \quad (1)$$

where s is longitudinal shift (see Fig. 4), $S_{x,y}$ are BPM sensitivities, and $\alpha_{x,y}$ are trajectory angle. Re-allocating buttons in such way that top and bottom buttons overlap eliminates such effect.

ID BPMS

The ID BPMS will be located in the insertion device straight sections and will require high mechanical and thermal stability. The user BPM consists of a special BPM block with BPM buttons, cooling fins and end flanges (Fig. 5). This assembly is mounted via four invar rods to the BPM support stand, made from carbon fiber composite. A carbon fiber composite can have thermal coefficient as low as $0.2 \mu\text{m}/\text{m}/^\circ\text{C}$. With tunnel temperature controlled to 0.1°C , one meter BPM stand will have a thermal expansion of no more than $\pm 20 \text{ nm}$. The resolution requirements for user BPMS are expected to be better by a factor of 2 in comparison with regular ones.

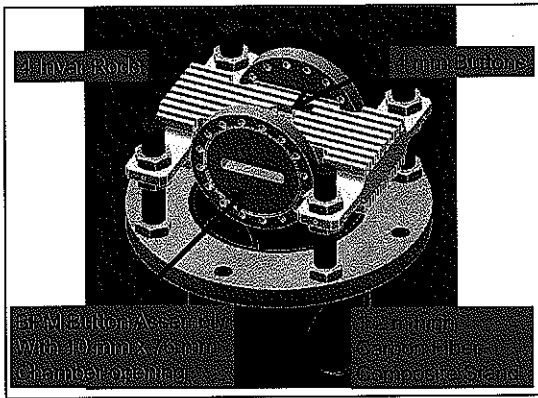

Figure 5: User BPM support stand with a BPM block mounted at its mid-plane.

We plan to install 4-mm button assembly with twin design utilized at APS. The evaluation showed that signal level should be sufficient and 10-mm button separation provides good sensitivity to beam motion.

The program on the evaluation of mechanical stability of supports is under way. We plan to measure the thermal expansion coefficient of carbon posts using a thermal chamber as well as commercially available services. The stand set-up is shown in Fig. 6. The post under test will be heated and its length variation compared to the reference post will be changed. The rigidity of support will be evaluated using ANSYS analysis and direct measurement of resonant frequency of mechanical vibrations.

RF BPM RECEIVERS

Commercially available, fast digital design based BPM electronics are being considered to meet various requirements and provides outputs such as 1) turn-by-turn block data for fast diagnostics, 2) 10 kHz data for orbit feedback, 3) 10 Hz data for orbit correction.

We will test Libera Brilliance [7] on the stand for the long term stability in the controlled environment; fill pattern dependence and thermal drifts.

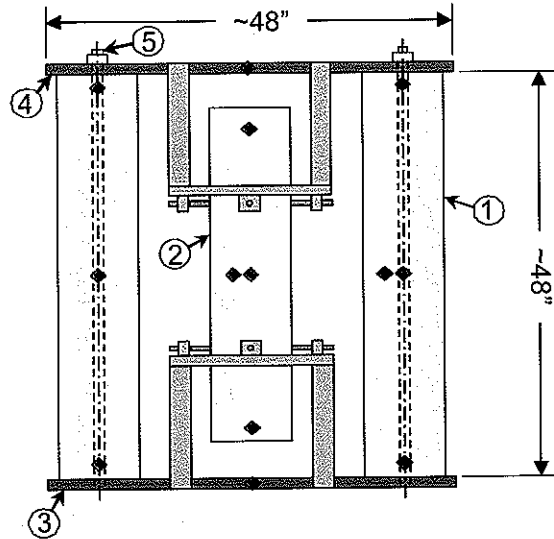

Figure 6: Layout of the test stand for user BPM post. The post under test 2 is hung between two stainless steel plates 3 and 4 mounted on two pillars 1. The pillars are made of the same carbon filament composite.

SUMMARY

We have presented an overview of RF beam position monitors for the NSLS-II project. The critical diagnostic systems, addressing beam stability and low emittance monitoring, are being investigated in the FY08 R&D program. Preliminary simulations, optimizing the RF BPM buttons, have been completed providing insight into the selection of an RF button geometry for prototype assembly. Preliminary design on various diagnostics systems has begun.

REFERENCES

- [1] "NSLS-II Preliminary Design Report", (2008); <http://pdr.nsls2.bnl.gov/default.aspx>.
- [2] I. Pinayev and O. Singh, "Evaluation of BPM button geometry for NSLS-II project," NSLS-II Technical Note..
- [3] A. Olmos, F. Pérez, G. Rehm, "Matlab Code for BPM Button Geometry Computation," Proc. of DIPAC 2007.
- [4] G. Kube, M. Werner, "Signal Level Calculation for the PETRA-III Beam Position Monitor System," Proc. of DIPAC 2007.
- [5] G. Decker, "Beam Stability in Synchrotron Light Sources", Proc. of DIPAC 2005, pp. 233-237.
- [6] G. Decker, "Beam Stability in Synchrotron Light Sources", proc. of DIPAC'05.
- [7] <http://www.i-tech.si>