

Method of Equivalencing for a Large Wind Power Plant with Multiple Turbine Representation

Preprint

E. Muljadi

National Renewable Energy Laboratory

S. Pasupulati

Oak Creek Energy Systems, Inc.

A. Ellis

Public Service Company of New Mexico

D. Kostrov

Bonneville Power Administration

To be presented at the 2008 IEEE Power Engineering Society

General Meeting

Pittsburgh, Pennsylvania

July 20–24, 2008

Conference Paper

NREL/CP-500-42886

July 2008

NREL is operated by Midwest Research Institute • Battelle Contract No. DE-AC36-99-GO10337



NOTICE

The submitted manuscript has been offered by an employee of the Midwest Research Institute (MRI), a contractor of the US Government under Contract No. DE-AC36-99GO10337. Accordingly, the US Government and MRI retain a nonexclusive royalty-free license to publish or reproduce the published form of this contribution, or allow others to do so, for US Government purposes.

This report was prepared as an account of work sponsored by an agency of the United States government. Neither the United States government nor any agency thereof, nor any of their employees, makes any warranty, express or implied, or assumes any legal liability or responsibility for the accuracy, completeness, or usefulness of any information, apparatus, product, or process disclosed, or represents that its use would not infringe privately owned rights. Reference herein to any specific commercial product, process, or service by trade name, trademark, manufacturer, or otherwise does not necessarily constitute or imply its endorsement, recommendation, or favoring by the United States government or any agency thereof. The views and opinions of authors expressed herein do not necessarily state or reflect those of the United States government or any agency thereof.

Available electronically at <http://www.osti.gov/bridge>

Available for a processing fee to U.S. Department of Energy and its contractors, in paper, from:

U.S. Department of Energy
Office of Scientific and Technical Information
P.O. Box 62
Oak Ridge, TN 37831-0062
phone: 865.576.8401
fax: 865.576.5728
email: <mailto:reports@adonis.osti.gov>

Available for sale to the public, in paper, from:

U.S. Department of Commerce
National Technical Information Service
5285 Port Royal Road
Springfield, VA 22161
phone: 800.553.6847
fax: 703.605.6900
email: orders@ntis.fedworld.gov
online ordering: <http://www.ntis.gov/ordering.htm>



Method of Equivalencing for a Large Wind Power Plant with Multiple Turbine Representation

E. Muljadi¹

S. Pasupulati²

A. Ellis³

D. Kosterev⁴

Abstract— As the size and number of wind power plants (WPP) increases, power system planners will need to study their impact on the power system in more detail. As the level of wind power penetration into the grid increases, the transmission system integration requirements will become more critical [1-2].

A very large WPP may contain hundreds of megawatt-size wind turbines. These turbines are interconnected by an intricate collector system. While the impact of individual turbines on the larger power system network is minimal, collectively, wind turbines can have a significant impact on the power systems during a severe disturbance such as a nearby fault. Since it is not practical to represent all individual wind turbines to conduct simulations, a simplified equivalent representation is required.

This paper focuses on our effort to develop an equivalent representation of a WPP collector system for power system planning studies. The layout of the WPP, the size and type of conductors used, and the method of delivery (overhead or buried cables) all influence the performance of the collector system inside the WPP. Our effort to develop an equivalent representation of the collector system for WPPs is an attempt to simplify power system modeling for future developments or planned expansions of WPPs. Although we use a specific large WPP as a case study, the concept is applicable for any type of WPP.

Index Terms—wind turbine, wind farm, wind power plant, wind energy, aggregation, equivalence, distribution network, collector system, power systems, systems integration, and renewable energy.

I. INTRODUCTION

Although it is very important to understand the dynamics of individual turbines [3-5], the collective

behavior of the WPP and the accuracy in modeling the collector systems are also very critical in assessing WPP characteristics. Among other aspects, the design of collector systems for wind power plants seeks to minimize losses and voltage drops within budgetary constraints. This philosophy is generally applied regardless of the size of the WPP, the types of the turbines, and reactive power compensation.

Within a WPP, wind turbines are placed optimally to harvest as much wind energy as possible. Turbine layout in a large WPP on flat terrain is different from the layout of a WPP located on mountain ridges. Different layouts will have different impacts on the line impedances to the grid interconnection bus. Some preliminary work on equivalencing is based on single turbine representation [6].

Some WPPs are built with different types of wind turbines for different reasons. For example:

- recent unavailability of new turbines because wind turbine supply lags behind demand for wind turbines
- the economic benefit of mixing wind turbine types within the same WPP
- re-powering old WPPs with newer and bigger turbines.

When this problem arises, analysis of WPPs must take into account the fact that the WPP can no longer be represented by a single generator. Obviously, the representation must be based on several considerations, as will be discussed in section II.

This paper describes an analytical approach that can be used to derive the equivalent representation of a WPP collector system. Many textbooks on distribution system modeling are available [7], but this paper focuses on modeling WPP collector systems in particular. To illustrate the methodology, we used data from the proposed WPP to be built in Tehachapi, California, interconnected to the transmission grid owned and operated by Sothern California Edison (SCE).

We acknowledge the financial support provided by the U.S. Department of Energy, California Energy Commission, and Western Electric Coordinating Council.

¹E. Muljadi is with National Renewable Energy Laboratory, Golden, CO 80401 (email: eduard_muljadi@nrel.gov).

²S. Pasupulati is with Oak Creek Energy Systems Inc., Mojave, and CA 93501 (email: subbaiah@oakcreekenergy.com).

³A. Ellis is with Public Service Company of New Mexico, Albuquerque, NM 87158 (e-mail: aellis@pnm.com).

⁴D. Kosterev is with Bonneville Power Administration, Vancouver, WA 98666 (email: dnkosterev@bpa.gov).

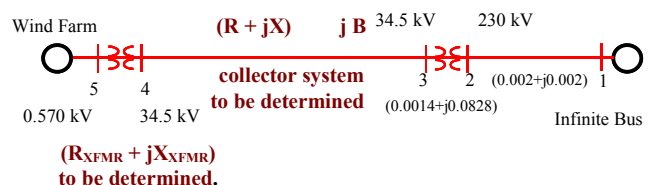

Figure 1. Simplified one-line diagram of a typical wind power plant connected to a substation.

Figure 1 shows a simplified one-line diagram for the single-machine equivalent of a WPP. For a very large installation, bus 1 is the point of interconnection connected to a step-up transformer that belongs to the 500-kV utility transmission system. Other projects are connected at 230 kV and the point of interconnection is at the bus 3 (low side of the substation transformer at 34.5 kV).

This paper is organized as follows: section II describes the steps we used to derive the equivalent impedance of a power system network. In section III, the technique of grouping wind turbines is presented. Section IV presents a case study representing WPP with multiple turbines. This paper is concluded in section IV. An additional Appendix is included that presents and tabulates the results of our calculations.

II. STEP BY STEP DERIVATION

A. General overview and assumptions

In this section, we describe the background of the circuit simplification. A modern utility-size wind turbine generates electrical power at a low voltage level (typically 575 V or 690 V). Current utility-scale wind turbine ratings range from 1.5 MW to 5 MW per turbine. Each wind turbine is electrically attached to a pad-mounted transformer that steps up the voltage to a medium voltage level, typically 34.5 kV.

The collector system is connected at the 34.5 kV level, where the wind turbines are connected to each other in a string or “daisy chain” configuration (Fig. 2). Underground cables are most commonly used in the collector system. Three or more turbines may be connected in this way to trunk lines, which then connect to one of possibly several feeder circuits that use a larger conductor. The collector system is connected to the WPP’s substation transformer. A substation transformer steps up the voltage from a sub-transmission voltage level to a transmission voltage level (60 kV or above).

In the following derivation, we based our equivalent

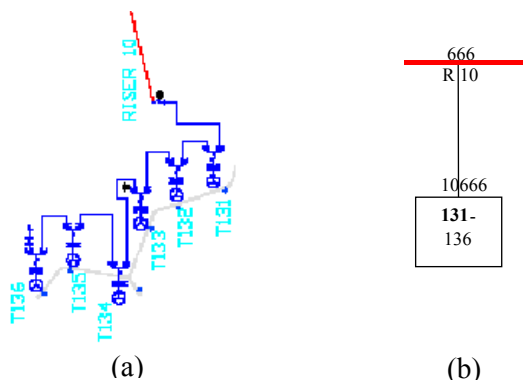

Figure 2 a) single series daisy-chain physical diagram
b) equivalent representation of circuit (a)

circuit on apparent power losses (i.e., real and reactive power losses). We made the following assumptions to derive the general equation for a circuit within a WPP:

- The current injection from all wind turbines is assumed to be identical in magnitude and angle.
- Reactive power generated by the line capacitive shunts is based on the assumption that the voltage at the buses is one per unit.

B. Connection at the trunk line level

Let’s consider a WPP consisting of different types of wind turbines of different sizes. Consider the equivalent circuit shown in Figure 3 where we have 4 turbines connected in a daisy chain fashion.

Let’s first consider the voltage drops across the line impedances. Across Z_1 , the voltage drop can be written as:

$$\Delta V_{Z1} = I_1 Z_1 = (S_1/V) Z_1 = (P_1/V) Z_1$$

Note that I_1 is substituted with S_1/V where S_1 is the rated apparent power of wind turbine #1. Based on the assumption that most wind turbines are compensated to have a very close unity power factor, the apparent power S_1 can be substituted by the rated power of wind turbine 1, P_1 . The rest of the equations can be used to describe the voltage drop across Z_1 through Z_4 .

$$\begin{aligned} \Delta V_{Z2} &= (I_1 + I_2) Z_2 \\ &= (P_1/V + P_2/V) Z_2 \\ &= (P_1 + P_2) Z_2/V \end{aligned}$$

$$\Delta V_{Z3} = (I_1 + I_2 + I_3) Z_3$$

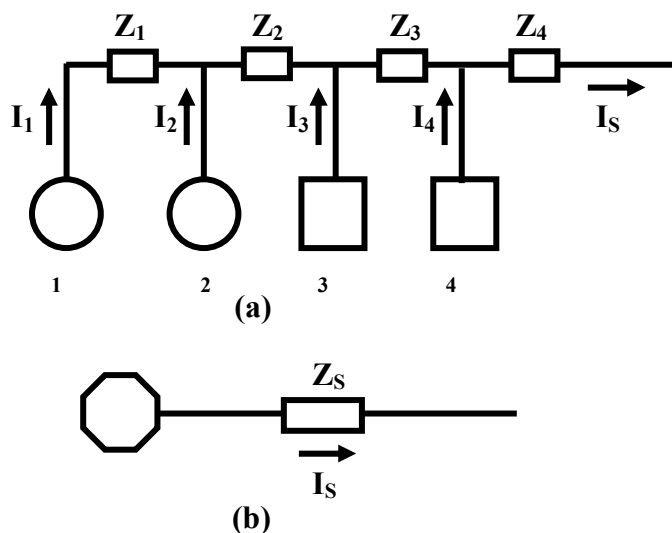

Figure 3. Equivalent four turbines
(a) Daisy-chain representation
(b) Equivalent circuit representation

$$= (P_1/V + P_2/V + P_3/V) Z_3$$

$$= (P_1 + P_2 + P_3) Z_3/V$$

$$= \{(P_1 + P_2 + P_3 + P_4)/V\} \{(P_1 + P_2 + P_3 + P_4)/V\}^* Z_S$$

$$\Delta V_{Z4} = (I_1 + I_2 + I_3 + I_4) Z_4$$

$$= (P_1/V + P_2/V + P_3/V + P_4/V) Z_4$$

$$= (P_1 + P_2 + P_3 + P_4) Z_4/V$$

or

$$S_{Loss_ZS} = (P_1 + P_2 + P_3 + P_4)^2 Z_S/V^2$$

or

$$S_{Loss_ZS} = P_{Z4}^2 Z_S/V^2$$

Next, we'll define a new variable, P_{Zi} , as the total power flow in the line segment represented by Z_i

The power loss in each line segment can be written as:

By equating the loss calculation, we get:

$$S_{Loss_Z1} = \Delta V_{Z1} I_1^*$$

$$= (P_1/V) (P_1/V)^* Z_1$$

$$= (P_1/V) (P_1^*/V^*) Z_1$$

$$= P_1^2 Z_1/V^2$$

$$= P_{Z1}^2 Z_1/V^2$$

$$S_{Loss_ZS} = S_{Loss}$$

$$P_{Z4}^2 Z_S/V^2 = (P_{Z1}^2 Z_1 + P_{Z2}^2 Z_2 + P_{Z3}^2 Z_3 + P_{Z4}^2 Z_4) /V^2$$

The general expression can be written as:

$$S_{Loss_Z2} = \Delta V_{Z2} I_2^*$$

$$= (P_1 + P_2)^2 Z_2/V^2 = P_{Z2}^2 Z_2/V^2$$

$$Z_S = \frac{\sum_{m=1}^n P_{Zm}^2 Z_m}{P_{Zn}^2}$$

$$S_{Loss_Z3} = \Delta V_{Z3} I_3^*$$

$$= (P_1 + P_2 + P_3)^2 Z_3/V^2$$

$$= P_{Z3}^2 Z_3/V^2$$

C. Shunt representation

$$S_{Loss_Z4} = \Delta V_{Z4} I_4^*$$

$$= (P_1 + P_2 + P_3 + P_4)^2 Z_4/V^2$$

$$= P_{Z4}^2 Z_4/V^2$$

Consider an equivalent circuit for the transmission line shown in Figure 4. Because the nature of the capacitance generates reactive power that is proportional to the square of the voltage across them, and considering that the bus voltage is close to unity under normal conditions, the representation of the shunt B can be considered as the sum of all the shunts in the power systems network. This assumption is close to reality under normal conditions.

Note that Z_4 is the last line segment in the daisy chain branch. The total loss can be computed as:

With the assumption presented above, we can compute the total shunt capacitance within the WPP as follows:

$$S_{Loss} = P_{Z1}^2 Z_1 + P_{Z2}^2 Z_2 + P_{Z3}^2 Z_3 + P_{Z4}^2 Z_4$$

$$B_{tot} = \sum_{i=1}^n B_i$$

From Figure 3b, we can compute the voltage drop across the equivalent impedance as:

D. Pad-mount Transformer Equivalencing

$$\Delta V_{ZS} = I_S Z_S$$

$$\text{Where } I_S = (P_1 + P_2 + P_3 + P_4)/V$$

The total loss in the equivalent impedance can be computed as:

$$S_{Loss_ZS} = \Delta V_{ZS} I_S^*$$

$$= I_S I_S^* Z_S$$

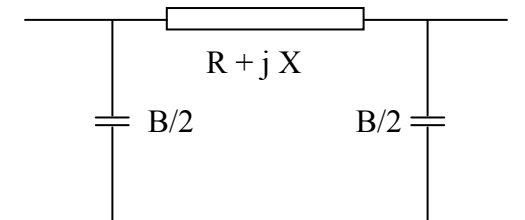

Figure 4. Representation of the line capacitance within a wind power plant.

The equivalence of the pad-mounted transformer at the turbine can be derived by using the illustration shown in Figure 5. In Figure 5a, the three-phase step up transformer connected to the wind turbines is shown. The impedance of a single turbine is given. Figure 5b shows the equivalence impedance to represent the entire group of the transformers (in this example, we have 4 turbines).

Next, we must consider parallel branches connected to the same nodes, as shown in Figure 5. Each branch has unique impedance and is connected to a wind turbine. Let's consider a simple daisy chain of four turbines of different sizes connected to the same node.

- Originally, each turbine has its own transformer with different ratings.
- All turbines are producing at rated output.
- The transformer impedances for each turbine are Z_{T1} , Z_{T2} , Z_{T3} , Z_{T4} , respectively.

Now let's consider the voltage drops across the line impedances. Note that I_1 is substituted with S_1/V where S_1 is the apparent power of wind turbine #1. Based on the assumption that each turbine generates equal current in magnitude and phase angle, and wind turbines are compensated to have a very close to unity power factor, the apparent power P_1 can be substituted by the rated power of wind turbine #1, P_1 . The rest of the equations can be used to describe the voltage drop across Z_{T1} through Z_{T4} .

Across Z_{T1} , Z_{T2} , Z_{T3} , Z_{T4} , the voltage drops can be written as:

$$\begin{aligned}\Delta V_{ZT1} &= I_1 Z_1 \\ &= (S_1/V) Z_1 \\ &= P_1 Z_1/V\end{aligned}$$

$$\Delta V_{ZT2} = (P_2/V) Z_2$$

$$\Delta V_{ZT3} = P_3 Z_3/V$$

$$\Delta V_{ZT4} = P_4 Z_4/V$$

Losses in individual transformer:

$$\begin{aligned}S_{Z1} &= \Delta V_{ZT1} I_1^* \\ &= P_1 Z_{T1}/V (P_1/V)^* \\ &= P_1 Z_{T1} P_1 / (V V)^* \\ &= P_1^2 Z_{T1}/V^2\end{aligned}$$

$$\begin{aligned}\Delta V_{ZTS} &= \{(P_1+P_2+P_3+P_4)/V\} Z_{TS} \\ &= \{(P_1+P_2+P_3+P_4)/V\} Z_{TS}\end{aligned}$$

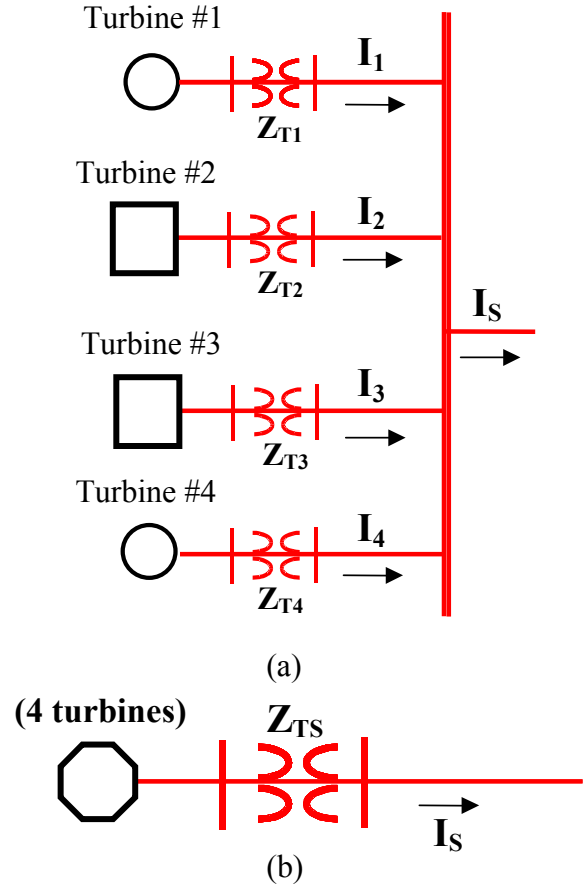

Figure 5. Equations for finding the equivalence of parallel connection of four turbines of different sizes.

$$= \{P_{Tot}/V\} Z_{TS}$$

$$S_{Z2} = P_2^2 Z_{T2}/V^2$$

$$S_{Z3} = P_3^2 Z_{T3}/V^2$$

$$S_{Z4} = P_4^2 Z_{T4}/V^2$$

The total loss is:

$$\begin{aligned}S_{ZS} &= \Delta V_{ZTS} I_S^* \\ &= P_{Tot}^2 Z_{TS}/V^2\end{aligned}$$

By substitution, we derived the following equations:

$$\begin{aligned}P_{Tot}^2 Z_{TS}/V^2 &= \\ P_1^2 Z_{T1}/V^2 + P_2^2 Z_{T2}/V^2 + P_3^2 Z_{T3}/V^2 + P_4^2 Z_{T4}/V^2\end{aligned}$$

The general expression can be written as:

$$Z_{TS} = \frac{\sum_{m=1}^n P_m^2 Z_{Tm}}{\sum_{m=1}^n P_m^2}$$

III. WIND TURBINE GROUPING

In this section, a method for grouping of turbines will be explored.

A. Groupings based on the diversity of the WPP

This grouping criterion is based on the diversity generally found in a very large WPP. For a very large WPP, the area within the power plant is very large. The number of turbines within the WPP can be a very high number, and sometimes it is not easy to get the same types of turbines due to limited supply. Or the WPP is expanded due to re-powering program.

- Diversity in wind speed: instantaneously, the wind speed at one corner of the WPP might be significantly different from the wind speed at the other corner of the WPP. Similarly, altitude diversity may be found in a large WPP which will lead to differences in wind speeds experienced by each wind turbine.

- Diversity in line impedance: in some WPPs, especially with significant diversity in the altitudes (WPPs with many hills), the locations of turbines are chosen based on the best wind resource. Thus, groups of turbines will be installed on top of one hill with significant distance with respect to the other groups of turbines. This diversity creates significant diversity in the size of the impedances connecting the groups of turbines to the point of interconnection.

- Diversity in turbine types: if there are almost equal numbers of different turbine types, it is appropriate to represent each turbine type within the WPP.

- Diversity in control algorithms: even within the same type, there could be different control algorithms implemented, thus creating groups of turbines with different response to the same excitations. For example, for Type 3 and Type 4 turbines, the wind turbine can be controlled to operate in Voltage Control mode or in Power Factor mode.

B. Groupings based on the transformer size

This is a convenient way to group wind turbines within large WPPs. WPP sizes are getting larger and larger. Presently, a 300-MW WPP size is considered a norm. The step-up transformer used however, is normally divided into smaller sizes for economic, reliability, and redundancy reasons. A 30 to 60-MVA transformer is commonly used to step up the voltage of a group of turbines. This method of grouping will probably be the most common type of grouping used in most new power plant cases.

C. Groupings based on the short circuit capacity

For a very large WPP, a single turbine representation (STR) or multiple turbine representation (MTR) should be used. MTR is chosen if there is a significant diversity within the WPP in terms of type of wind turbines, impedance levels of the line feeder, different control algorithms, or different wind turbine manufacturers.

In many cases, newer WPPs are represented by a single wind turbine representation because the wind developer usually chooses the same type of wind turbine within the same WPP. If multiple turbine representation is chosen, the WPP must be represented by several wind turbines. Each wind turbine represents a group of turbines with the same characteristics. The number groups within a single WPP can be determined based on the size of the generated rated power of the group.

A WPP connected to a grid with multiple wind turbine representation must be represented by groups of wind turbines. Since Short Circuit Capability (SCC) determines the level of grid stiffness, which also governs its stability characteristic (both voltage and phase angle), and the impact of the WPP on the power grid, it is convenient to express the grouping of the wind turbines by its group size in percentage of its SCC at the point of interconnection. For example, a 150-MW WPP might include 75 MW of turbine Type 1, 5 MW of turbine Type 2, 60 MW of turbine Type 3, and 10 MW of turbine Type 4. With the system base of 100 MVA and the grid has an SCC=5, and, there are four groups of wind turbines within a 150MW WPP. In terms of its SCC, we can divide the group of turbines into:

$$\text{Type 1: } 75/(5*100) = 15\% \text{ SCC}$$

$$\text{Type 2: } 5/(5*100) = 1\% \text{ SCC}$$

$$\text{Type 3: } 60/(5*100) = 12\% \text{ SCC}$$

$$\text{Type 4: } 10/(5*100) = 2\% \text{ SCC}$$

Note that the impact of Type 4 wind turbine generators (WTGs) is very small (1%SCC) compared to the impact of Type 1 WTGs. In this case, it might be useful to combine Type 4 into another group with similar characteristics. From the nature of its behavior, we recommend that Type 1 and Type 2 be considered to have similar behavior, and Types 3 and 4 be considered to have similar behavior. We do not recommend combining Type 1 and Type 3, or Type 2 and Type 3, or Type 2 and Type 4, or Type 1 and Type 4. By regrouping Type 2 turbines into the Type 1 group as shown in the example below, the number of turbine representations can be reduced, thus simplifying the calculation.

$$\text{Type 1 : } 80/500 = 16\% \text{ SCC}$$

$$\text{Type 3 : } 60/500 = 12\% \text{ SCC}$$

$$\text{Type 4 : } 10/500 = 2\% \text{ SCC}$$

The planner may decide that a group of wind turbines with a total output power of less than 5% of the SCC can be combined into a group with a similar type of turbines to reduce the number of turbine representations. In this case, for a stiffer grid, the grouping allocation will change.

For example, the above list of groups can be rewritten for SCC= 10 as follows:

- Type 1 : 75/1000 = 7.5% SCC
- Type 2 : 5/1000 = 0.5% SCC
- Type 3 : 60/1000 = 6% SCC
- Type 4 : 10/1000 = 1% SCC

Which can be simplified into;

- Type 1 : 80/1000 = 8% SCC
- Type 3 : 70/1000 = 7% SCC

This can be considered to be the simplest form of wind turbine representation without losing the significant characteristics of the major turbine contributions. The proportion of the wind turbine types representing the turbine group indicates the influence of the WPP on the power grid (i.e. WPP with the stiffer grid will have a lower impact on the power grid).

IV. CASE STUDY: MULTIPLE TURBINE REPRESENTATION

In this section an example of equivalencing a WPP is presented in Figure 6. This WPP consists of non-uniform turbines. In this power plant, only two kinds of wind turbines will be considered; 1 MW of Type 1

(fixed-speed induction-generator wind turbine) and 3 MW of Type 4 (variable-speed wind turbine with full power converter).

The basic assumptions used in the equivalencing method are:

- assume that all turbines generate rated power at rated current
- equate the losses within the branch to the total losses
- find the equivalence impedance
- assume that inter-turbine cables required is equal to 400 feet.

Since we are interested only on the impedance between two turbines, and, for the simplicity, we use 400 feet as the distance between two turbines. This number is sufficient for the unit turbine chosen 3.16 MW (distance between this two turbines is more than 3 times blade diameter).

In this equivalencing method, the calculation for impedance is taken from the data provided (based on the cable chosen). Using the collector medium voltage of 34.5 kV as our base voltage, and the base apparent power of 100 MVA, we can find the base impedance Z_{base} in Table I.

Table 1. Base at the Collector System

	KVLL (kV)	SBASE (MVA)	Zbase (ohms)
Base	34.5	100	11.9025

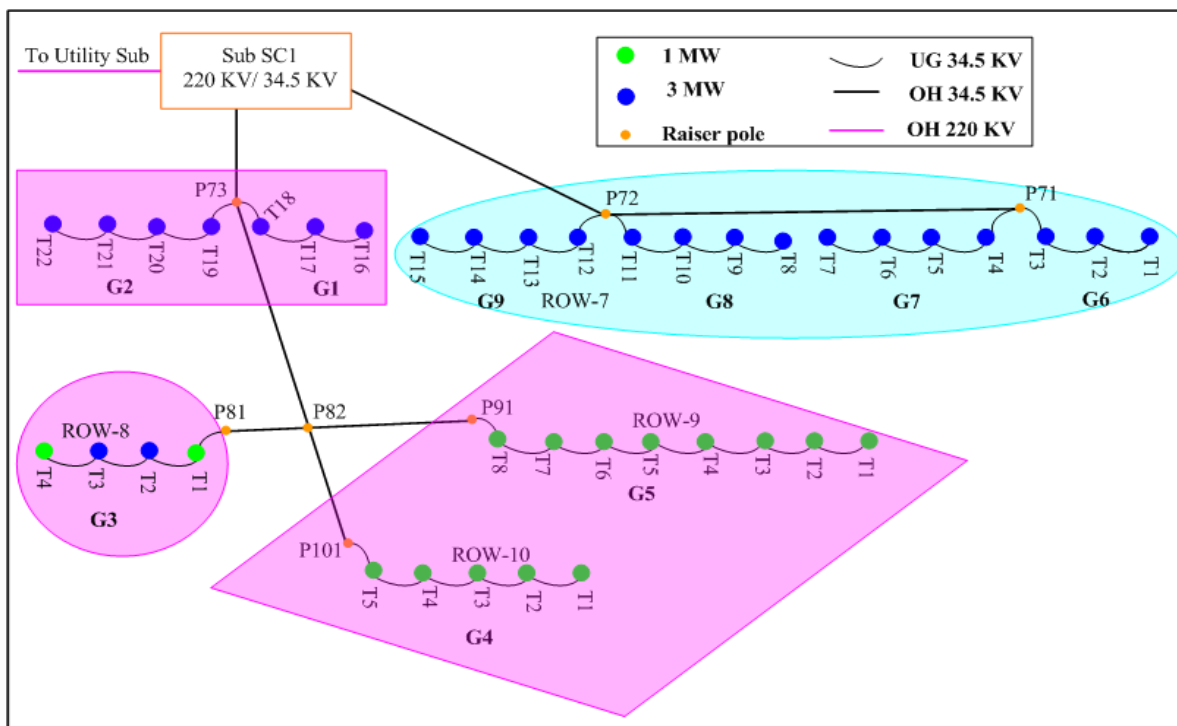

Figure 6. Groups of turbines within a wind power plant.

Table 2. Typical Values Used

34.5 kV	R ohm/ft	X ohms/ft	R pu/ft	X pu/ft
Under Gr.	1.150E-04	9.200E-05	9.662E-06	7.729E-06
Over Head	2.220E-05	1.181E-04	1.865E-06	9.920E-06

Table 3. Daisy Chain Equivalencing

Branch		Gen MW	Dist. in Feet	R in pu	X in pu	Power flow in branch	P^2 R	P^2 X
From	To							
34.5 kV UG - Group 3								
T3	T4	1	400	0.0039	0.0031	1	0.00386	0.00309
T2	T3	3	400	0.0039	0.0031	4	0.06184	0.04947
T1	T2	3	400	0.0039	0.0031	7	0.18937	0.1515
P81	T1	1	400	0.0039	0.0031	8	0.24734	0.19787
Total Gen		8						
34.5 KV OVER HEAD								
P82	P81		1774	0.0033	0.0176	8	0.21173	1.12623
Total							0.71415	1.52817
							0.01116	0.02388
							Req	Xeq

Table 4. Pad-Mount Transformer Equivalencing

Transformer		Gen Rating MW	Transf. Imp	R in pu	X in pu	Power Flow in Transf.	P^2 R	P^2 X
From	To							
Group 3								
T3	T4	1	ZT4	0	6.8182	1	0	6.81818
T2	T3	3	ZT3	0	3.0063	3	0	27.057
T1	T2	3	ZT2	0	3.0063	3	0	27.057
P81	T1	1	ZT1	0	6.8182	1	0	6.81818
Total		8					0	67.7503
							0	1.0586
							Req	Xeq

Table 5. Summary of Groups Impedance

Group Name	Tot. Pwr MW	# of Turb	Type	Turb. MW	Collector Impedance Z(p.u.)	Trafo Reactance X(p.u.)
Rectangle	21	7	1	4	0.0312+j0.025	0.4295
Circle	8	4	1,3	1,4	0.0112+j0.024	1.0586
Diamond	13	13	1	1	0.0074+j0.018	0.5245
Ellipse	45	15	4	4	0.0064+j0.026	0.2004

Table 6. Summary of Overhead Impedance

Branch Description		Power Flow (MW)	Distance (Feet)	R in pu	X in pu
From	To				
34.5 KV OVER HEAD					
P101	P82	5	1577	0.0029	0.0156
P91	P82	8	3075	0.0057	0.0305
P82	P81	8	1774	0.0033	0.0176
P82	P73	21	1576	0.0029	0.0156
P72	SUB A-3-1	42	1200	0.0022	0.0119

The typical values of the underground cable and overhead wire impedance in ohms and in per unit are given in Table 2.

As shown in Figure 6, the WPP is divided into 9

groups of turbines connected in daisy chain fashion. The number of turbines within each group varies from 3 to 8 turbines.

From this layout, we can configure the WPP into four turbine representations. Different geometrical shapes are used to form the boundary of each turbine representation.

There are two types of turbines installed in this WPP. One type of turbine is a Type 1 WTG rated at 1 MW, and another type is Type 4 WTG with a rating of 3 MW.

Two major feeders connect the groups of turbines to two transformers. The first feeder connects the three turbine representations; the rectangle representation, the circle representation, and the diamond representation. Another feeder connects the groups of turbines enclosed by the ellipse shape.

The turbine representations enclosed the ellipse (from G6 through G9) are connected to this feeder. Each group consists of three to four turbines and each turbine is rated at 3MW of Type 4 turbines.

Turbine representations enclosed by the diamond shape consist of 1MW wind turbines of Type 1. Group G4 consists of 5 turbines of 1MW connected and daisy chain, and group G5 consists of 8 turbines of 1 MW connected in daisy chain.

Turbine representations enclosed by the circle consist of only one group G3, which is made of mixed types of turbines (two 1-MW wind turbines of Type 1 and 2 and two 3-MW wind turbines of Type 4). Since G3 has 75% of the total output represented by wind turbine Type 4, the group G3 will be treated as Type 4 turbines in the analysis and dynamic simulation, because the contribution of the Type 1 turbine within this group is much smaller than the contribution of Type 4 turbines.

The rest of the turbines enclosed by the rectangle represented by groups G1 and G2 consist of 3 MW of Type 4 wind turbines.

An example of the calculation for a daisy chain turbine representation can be presented in Table 3. This example is taken from the group G3 illustrated as a group of turbines within the circular boundary shown in Figure 6. Note, that this group is represented as 8 MW of wind turbine capacity using Type 4 instead of Type 1.

Table 4 shows the calculation for pad-mounted transformer impedance for group 3 (G3). The calculation for the rest of the turbine representations (rectangle, diamond, and ellipse) can be performed the same way.

Table 5 shows the calculation of the underground cables for the groups of turbines. For example, row 2 (turbines bounded by circle) of the Table 5 is the result calculated from Table 1. Using similar calculations derived in

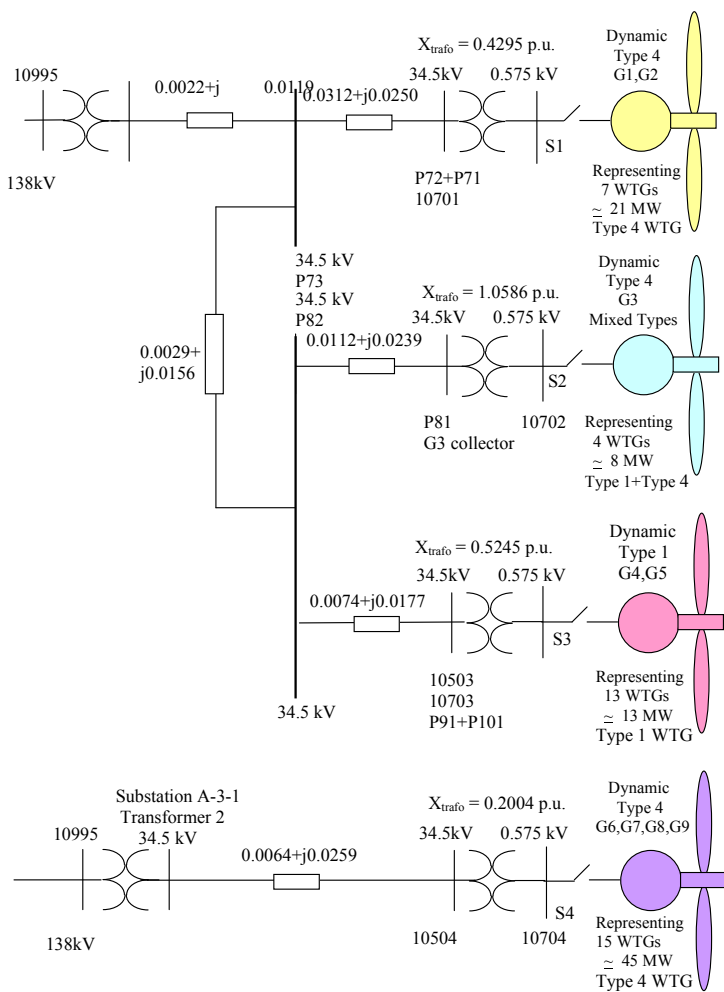

Figure 7. A wind power plant with a four-turbine representation.

Table 1, representation of the other turbines bounded by rectangle, diamond, and ellipse can be derived.

Table 6 contains the impedances of overhead lines interconnecting the rectangle, circle, diamond, and ellipse shapes, and the substation transformer shown in Figure 6.

The summary of the calculations for the collector system representation is presented in the Table 4 and Table 5. From Tables 4, 5, and 7, we can draw the four turbine representations of the WPP shown in Figure 7.

Further simplifications might be considered in lieu of the complete circuit presented previously and based on the assumption that the simplification will not affect the accuracy of the simulation significantly. We can use the equivalent circuit show in Figure 7 as the starting point. Figure 8 shows the two turbine representations of the WPP. The first turbine representation is Type 1 wind turbine, and the second one is Type 4 wind turbine. Note, that there are 2 turbines of Type 1 being lumped into the 24 Type 4 wind turbines.

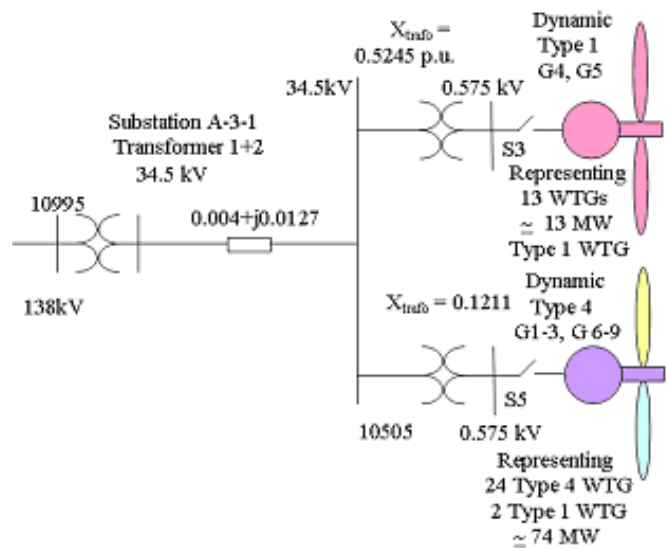

Figure 8. A simplified wind power plant representation with a two turbine representations.

The calculations to convert from the “four turbine representation” as shown in Figure 7 into the “two turbine representation” as shown Figure 8 are listed in Appendix 1.

V. CONCLUSION

This paper describes methods used to represent WPPs by equivalence. For various reasons, some WPPs are built with different wind turbines. This diversity of WPPs needs to be represented.

One important aspect of equivalencing is to find a way to group wind turbines into larger group that sufficiently represents the overall characteristics of the WPPs. In section III, several methods of grouping are presented.

As an example, a case study of a WPP (100 MW) with two substation transformers is presented. Step-by-step equivalencing of the impedances and shunt capacitances is shown to represent the WPP into a four-turbine representation. Further reduction into a two-turbine representation is also shown.

Finally, the decision to represent the WPP in a power system study depends on the power system planners. Any major diversity in the WPP with major contributions to the total output power of the WPP should be represented in the WPP model.

VI. ACKNOWLEDGMENT

We acknowledge the support of the U.S. Department of Energy, Oak Creek Energy Systems Inc., the Western Electric Coordinating Council, and the project funding provided by the California Energy Commission's PIER

Program. This work is part of a larger project called WECC Wind Generator Modeling.

VII. REFERENCES

- [1] Zavadil, R.; Miller, N.; Ellis, A.; Muljadi, E. "Making Connections," *Power and Energy Magazine*, IEEE, Vol. 3, Issue 6, Nov.-Dec. 2005, pp. 26-37.
- [2] Zavadil, R.M.; Smith, J.C. "Status of Wind-Related U.S. National and Regional Grid Code Activities," *Power Engineering Society General Meeting*, June 12-16, 2005, pp. 2892-2895.
- [3] Miller, N.W.; Sanchez-Gasca, J.J.; Price, W.W.; Delmerico, R.W. "Dynamic Modeling of GE 1.5 and 3.6 MW Wind Turbine-Generators for Stability Simulations," *Power Engineering Society General Meeting*, IEEE, Vol. 3, July 13-17, 2003, pp. 1977-1983.
- [4] Miller, A.; Muljadi, E.; Zinger, D. "A Variable-Speed Wind Turbine Power Control," *IEEE Transactions on Energy Conversion*, Vol. 12., No. 2, June 1997 pp. 181-186.
- [5] Tande, J.O.G.; Muljadi, E.; Carlson, O.; Pierik, J.; Estanqueiro, E.; Sørensen, P.; O'Malley, M.; Mullane, A.; Anaya-Lara, O.; Lemstrom, B.; "Dynamic models of wind farms for power system studies—status by IEA Wind R&D Annex 21," European Wind Energy Conference & Exhibition (EWEC), London, U.K., November 22-25, 2004.
- [6] Muljadi, E.; Butterfield, C.P.; Ellis, A.; Mechenbier, J.; Hocheimer, J.; Young, R.; Miller, N.; Delmerico, R.; Zavadil, R.; Smith, J.C.; "Equivalent the Collector System of a Large Wind Power Plant", presented at the IEEE Power Engineering Society, Annual Conference, Montreal, Quebec, June 12-16, 2006.
- [7] Kersting, W.H. *Distribution System Modeling and Analysis*, CRC Press, Boca Raton, FL, 2001.

APPENDIX I.

The table presented below is the calculation performed to transfer the WPP from a four-turbine representation to a two-turbine representation.

Branch Description		Group Rating	R in pu	X in pu	Power Flow in Branch	P^2 R	P^2 X
From	To	(MW)					
34.5 kV OH							
G1_G2	P73	21	0.0312	0.0250	21	13.7739	11.0191
G3	P82	8	0.0112	0.0239	8	0.7141	1.5282
G4_G5	P82	13	0.0074	0.0177	13	1.2531	2.9933
P82	P73	21	0.0029	0.0156	21	1.2961	6.8943
P73	SUB A-3-1	42	0.0022	0.0119	42	3.9476	20.9978
Total Output Power of WPP					42	20.9849	43.4327
						0.0119	0.0246
						Req	Xeq
G1_G5	SUB A-3-1	42	0.0119	0.0246	42	20.9849	43.4327
G6_G9	SUB A-3-1	45	0.0064	0.0259	45	12.9487	52.5281
Total					87	33.9336	95.9608
						0.0045	0.0127
						Req	Xeq

Transformer Description		Group Rating	R in pu	X in pu	Power Flow in Transf.	P^2 R	P^2 X
	Imped.	(MW)					
G1_G2	ZT1	21	0.0000	0.4295	21	0.0000	189.3987
G3	ZT2	8	0.0000	1.0586	8	0.0000	67.7503
G6_G9	ZT4	45	0.0000	0.2004	45	0.0000	405.8544
Total Gen		74					
Total						0.0000	663.0035
						0.0000	0.1211
						Req	Xeq

Transformer Description		Group Rating	R in pu	X in pu	Power Flow in Transf.	P^2 R	P^2 X
	Imped.	(MW)					
G4_G5	ZT3	13	0.0000	0.5245	13	0.0000	88.6364
Total Gen		13					
Total						0.0000	88.6364
						0.0000	0.5245
						Req	Xeq

VIII. BIOGRAPHIES



Eduard Muljadi received his Ph. D. (in Electrical Engineering) from the University of Wisconsin, Madison. From 1988 to 1992, he taught at California State University, Fresno, CA. In June 1992, he joined the National Renewable Energy Laboratory in Golden, Colorado. His current research interests are in the fields of electric machines, power electronics, and power systems in general with emphasis on renewable energy applications. He is member of Eta Kappa Nu, Sigma Xi and a Senior Member of IEEE. He is involved in the activities of the IEEE Industry Application Society (IAS), Power Electronics Society, and Power Engineering Society (PES). He is currently a member of Industrial Drives Committee, Electric Machines Committee, and Industrial Power Converter Committee of the IAS, and a member of Working Group on Renewable Technologies and Dynamic Performance Wind Generation Task Force of the PES. He holds two patents in power conversion for renewable energy.

Subbaiah Pasupulati graduated from University of Texas, Arlington with an M.S. in Electrical Engineering in 2003. From 2003 to 2005, he was with Energy Unlimited Inc., a Wind Power Plant in Palm Spring, California where he was responsible to oversee the operations of the plant. He joined Oak Creek Energy System Inc. (OCES) in 2006. He is currently the Power System Engineer at OCES, he involved in design and development of 2.5 GW plus wind power plants in the Tehachapi area. He participated in California Southern Regional Transmission Plan 2006 conducted by California Independent System Operator which came up with Tehachapi's Renewable Transmission Plan. He is a member of the IEEE. He is an active member of WECC's Technical Studies Subcommittee & Wind Generator Modeling Group



Abraham Ellis graduated from New Mexico State University in 2000 with a Ph.D. in Electrical Engineering. In 2001, he joined the Transmission Operations Department at Public Service Company of New Mexico, where he works in the areas of large generator interconnection studies, transmission expansion planning and special projects related to transmission system performance and monitoring. Abraham is involved with various activities related to wind energy at the regional and national level. He currently coordinates Western Electricity Coordinating Council's Wind Generator Modeling Group and the IEEE Wind Generator Dynamic Performance Task Force. He also served as Chairman of the Modeling and Validation Work Group until July 2007. Abraham is a Senior Member of IEEE and is a registered Professional Engineer in the State of New Mexico.



Dmitry Kosterev received Ph.D. from Oregon State University in 1996. Dr. Kosterev is currently with Bonneville Power Administration, where his responsibilities include transmission planning, power system modeling, and power system controls. Dr. Kosterev was involved in analysis and model validation of 1996 outages that occurred in the Western Interconnection. Dr. Kosterev has been involved in testing, model validation, and dynamic performance monitoring of a number of hydro- and thermal- power plants in Pacific Northwest. Dr. Kosterev led WECC Generator Testing Task Force through development and approval of Generating Unit Model Validation Policy in 2006. Dr. Kosterev is a chair of WECC Modeling and Validation Work Group and WECC Load Modeling Task Force. Dr. Kosterev received Eugene Starr award for technical excellence from BPA Administrator in 2005.

REPORT DOCUMENTATION PAGE

Form Approved
OMB No. 0704-0188

The public reporting burden for this collection of information is estimated to average 1 hour per response, including the time for reviewing instructions, searching existing data sources, gathering and maintaining the data needed, and completing and reviewing the collection of information. Send comments regarding this burden estimate or any other aspect of this collection of information, including suggestions for reducing the burden, to Department of Defense, Executive Services and Communications Directorate (0704-0188). Respondents should be aware that notwithstanding any other provision of law, no person shall be subject to any penalty for failing to comply with a collection of information if it does not display a currently valid OMB control number.

PLEASE DO NOT RETURN YOUR FORM TO THE ABOVE ORGANIZATION.

1. REPORT DATE (DD-MM-YYYY) July 2008		2. REPORT TYPE Conference Paper		3. DATES COVERED (From - To)		
4. TITLE AND SUBTITLE Method of Equivalencing for a Large Wind Power Plant with Multiple Turbine Representation: Preprint				5a. CONTRACT NUMBER DE-AC36-99-GO10337		
				5b. GRANT NUMBER		
				5c. PROGRAM ELEMENT NUMBER		
6. AUTHOR(S) E. Muljadi, S. Pasupulati, A. Ellis, and D. Kosterov				5d. PROJECT NUMBER NREL/CP-500-42886		
				5e. TASK NUMBER WW1K1000		
				5f. WORK UNIT NUMBER		
7. PERFORMING ORGANIZATION NAME(S) AND ADDRESS(ES) National Renewable Energy Laboratory 1617 Cole Blvd. Golden, CO 80401-3393				8. PERFORMING ORGANIZATION REPORT NUMBER NREL/CP-500-42886		
9. SPONSORING/MONITORING AGENCY NAME(S) AND ADDRESS(ES)				10. SPONSOR/MONITOR'S ACRONYM(S) NREL		
				11. SPONSORING/MONITORING AGENCY REPORT NUMBER		
12. DISTRIBUTION AVAILABILITY STATEMENT National Technical Information Service U.S. Department of Commerce 5285 Port Royal Road Springfield, VA 22161						
13. SUPPLEMENTARY NOTES						
14. ABSTRACT (Maximum 200 Words) This paper focuses on our effort to develop an equivalent representation of a Wind Power Plant collector system for power system planning studies.						
15. SUBJECT TERMS wind turbine; wind farm; wind power plant; wind energy; aggregation; equivalence; distribution network; collector system; power systems; systems integration; renewable energy						
16. SECURITY CLASSIFICATION OF:			17. LIMITATION OF ABSTRACT UL	18. NUMBER OF PAGES	19a. NAME OF RESPONSIBLE PERSON	
a. REPORT Unclassified	b. ABSTRACT Unclassified	c. THIS PAGE Unclassified			19b. TELEPHONE NUMBER (Include area code)	

Standard Form 298 (Rev. 8/98)
Prescribed by ANSI Std. Z39.18