

Scenarios for Consuming Standardized Automated Demand Response Signals

Ed Koch

Akuacom
25 Bellam Blvd., Suite 215
San Rafael, CA 94903
ed@akuacom.com

Mary Ann Piette

Lawrence Berkeley National Laboratory
Building 90-3111
Berkeley CA 94720
mapiette@lbl.gov

Keywords: Demand response, automation, commercial buildings, architecture

Abstract

Automated Demand Response (DR) programs require that Utility/ISO's deliver DR signals to participants via a machine to machine communications channel. Typically these DR signals constitute business logic information (e.g. prices and reliability/shed levels) as opposed to commands to control specific loads in the facility. At some point in the chain from the Utility/ISO to the loads in a facility, the business level information sent by the Utility/ISO must be processed and used to execute a DR strategy for the facility. This paper explores the various scenarios and types of participants that may utilize DR signals from the Utility/ISO. Specifically it explores scenarios ranging from single end user facility, to third party facility managers and DR Aggregators. In each of these scenarios it is pointed out where the DR signal sent from the Utility/ISO is processed and turned into the specific load control commands that are part of a DR strategy for a facility. The information in these signals is discussed. In some cases the DR strategy will be completely embedded in the facility while in others it may be centralized at a third party (e.g. Aggregator) and part of an aggregated set of facilities. This paper also discusses the pros and cons of the various scenarios and discusses how the Utility/ISO can use an open standardized method (e.g. Open Automated Demand Response Communication Standards) for delivering DR signals that will promote interoperability and insure that the widest range of end user facilities can participate in DR programs regardless of which scenario they belong to.

1. AUTOMATED DEMAND RESPONSE SIGNALS

Demand Response (DR) programs can take many forms. DR programs differ from normal rates and tariffs in that they are designed to allow for the Utility/ISO to take specific actions to influence the load profiles of facilities that participate in the DR programs at peak consumption times on the grid. These peak consumption periods may cause critical grid reliability issues which must be addressed, but they may also trigger economic factors wherein the price of electricity reaches critical levels which may be ameliorated by reducing the overall consumption on the grid during those periods. These critical periods in which the Utility/ISO needs to influence the load profile of a Facility are referred to as DR Events. Much of DR today is managed as a set of programs in which the participants enter into some contractual agreement about how they will get compensated by participating in the DR Events. As the real time pricing markets evolve the notion of being compensated during a specific event period may get replaced with a purely price responsive mechanism that does not require that the facility be explicitly notified that a DR Event per se is occurring.

The manner in which the Utility/ISO influences the load profile of a facility is to send out a so called DR signal which is specific to the DR Event. The nature of the information in the DR signal varies widely depending upon the DR program. In some cases the DR signals contains business level information such as the following:

- Prices
- Shed levels
- Grid reliability related information

- Baselines

In other cases the DR signal may contain information that is related to controlling loads such as:

- Specific device commands such as a command to turn on or off a specific device in the facility
- Generalized device state information such as temperature set points for HVAC systems.
- Desired facility state information such as “low occupancy mode”

This paper is focused on so called Automated DR and therefore by definition the DR signals that are sent out by the Utility/ISO are utilized by machines that enable the response to the DR signals to occur in an automated fashion.

Ultimately it is the loads within the facility that are affected during DR Events, but the individual facilities are not the only parties that may utilize DR signals and act on them. In some cases there may be third party intermediaries (e.g. Aggregators) that may play a role in consuming a DR signal and determining how a facility responds to it. There are a number of possible such intermediaries that may play a role in this process and these will be covered in more detail in a subsequent section of this paper.

Regardless of whether the individual facility is consuming the DR signal or some intermediary on their behalf, there is a fundamental process which occurs that transforms the business level information that originally triggered the DR Event into a set of load control commands that affect the actual loads. This is depicted in Figure 1.

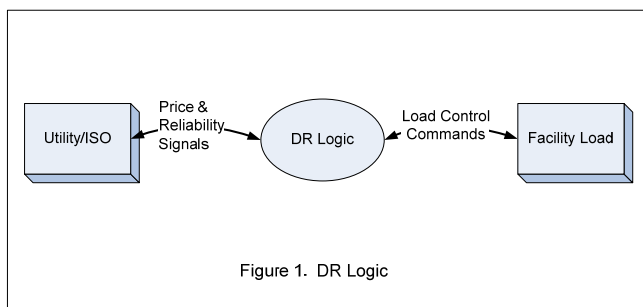

Figure 1. DR Logic

The process of making this conversion is referred to as “DR Logic”. A simple example of DR Logic may be the implementation of a rule such as:

If the electricity price is greater than \$0.25 then set thermostat from 72 to 78 °F and turn off lights in loading dock.

The DR Logic may be simple as shown above or it may be complex and include such things as pre-cooling before the DR Event or possibly involve the modification of a complex industrial process. In short, the DR Logic represents the points in the system where business level information related to a DR Event is converted into control level information that can be used to control specific loads in a facility.

This paper is focused on where this DR Logic resides and how it effects interoperability. In general the DR Logic may reside anywhere from the Utility/ISO to a third party intermediary to the facility and even the load itself.

It should be noted that for any DR program or dynamic tariffs there are many potential interactions between the Utility/ISO and the DR participants besides just sending/receiving a DR signal. These interactions may include the following:

- Collection of information prior to the DR event to allow the Utility/ISO to predict the expected load response to a DR signal.
- Monitoring of loads during DR Events to determine how participants are responding and to insure that they are behaving as expected.
- Collection of information after the end of the DR event to allow post mortem activities such as financial settlement between the Utility/ISO and the parties that participated in the DR event.

While each of the above described interactions are worthy of consideration and may play a crucial role in any DR program this paper only focuses on the delivery of DR signals which is the one interaction that is shared by all automated DR programs.

2. FACILITIES AND DR STRATEGIES

In general the term facility is used somewhat loosely and refers to any location in which there are loads that may be influenced by DR Events. These can include residential, commercial and industrial facilities. Furthermore the facilities may be as simple as a single building or as complex as a campus with multiple buildings perhaps controlled by a centralized control system. This paper focuses more on commercial and industrial facilities where there is a well established marketplace of control systems that are already deployed and available to be used to control loads for the purposes of automated DR. This does not preclude the same principles and concepts presented in this paper from being applied to the residential space.

A simple generalized diagram of a facility is shown in Figure 2.

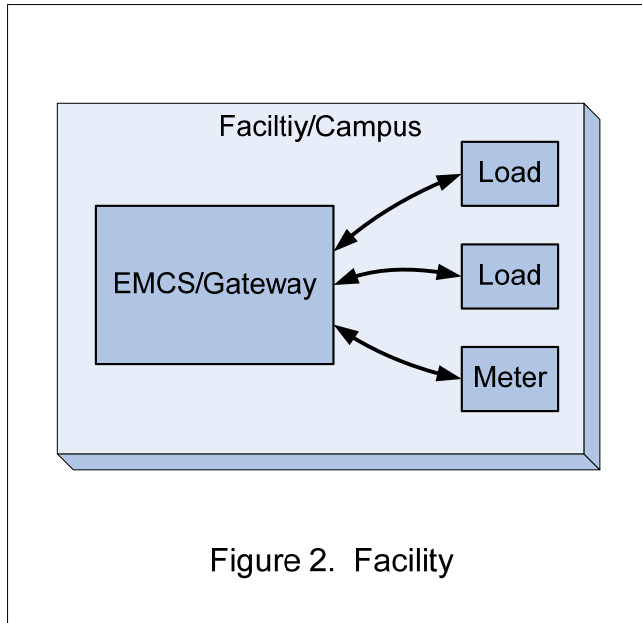

Figure 2. Facility

Regardless of whether a facility is a single building or a campus, for the purposes of this paper all facilities share the following elements:

- Loads which may be controlled in some automated fashion. These loads must have the ability to either receive load control commands or a DR signal directly. This implies that it has some means to communicate as well as control the load.
- Metering which can be used to measure the consumption of the facility.
- An Energy Management Control System (EMCS) or a gateway. Typically for larger commercial and industrial facilities there is an existing control system which utilizes some sort of centralized controller that is networked to a variety of load controls for the purpose of managing the operations of the facility. The centralized controller can be used as an EMCS for the purposes of DR and used to implement the DR Logic. In some cases there may simply be a gateway that allows DR signals or load control commands from external sources to reach the loads.

The types of loads that are used for the purposes of responding to DR Events vary depending upon the type of facility. In the case of commercial facilities it is typically heating, ventilation or air-conditioning (HVAC) and lighting loads while in the case of industrial facilities it

depends on the activities at the plant and can include peripheral equipment or primary process systems..

In addition to the loads being controlled, there is a so called DR strategy that is employed for each facility. Strategies vary widely depending upon the facility and range from direct load shedding during the event to load shifting as is used sometimes in the case of pre-cooling buildings. This paper does not focus on the strategies themselves, but instead focuses on the architecture for implementing the DR Logic which embodies the strategies.

Figure 3 shows three different scenarios of where the DR Logic is implemented with respect to the facility where the loads are controlled.

In case 3a the DR Logic is encapsulated within the EMCS system of the Facility. This means that the DR signal containing the business level information is translated into load control commands by the EMCS which are transmitted to the various loads in the facility. The benefit of this approach is that the EMCS can implement system wide logic for the entire facility.

In scenario 3b there is a gateway that transmits the DR signal containing the business level information directly to the load which has a controller that implements the DR Logic that translates the information in the Dr signal into a device state. The down side of this approach is that there is no centralized facility level DR Logic.

In scenario 3c the DR Logic is implemented at some entity outside the facility like the Utility/ISO, or some intermediary like an Aggregator. The DR Logic translates the business level information to load control commands and transmits these to the facility.

The important thing to note in Figure 3 is that the nature of the signals sent to the facility is dictated by where the DR Logic is implemented. In cases 3a and 3b a DR signal containing business level information (i.e. prices or shed levels) may be sent to the facility while in the case of 3c load control commands are sent. For the purposes of this paper 3a and 3b are considered equivalent since they both involve the same type of DR signal being sent to the facility.

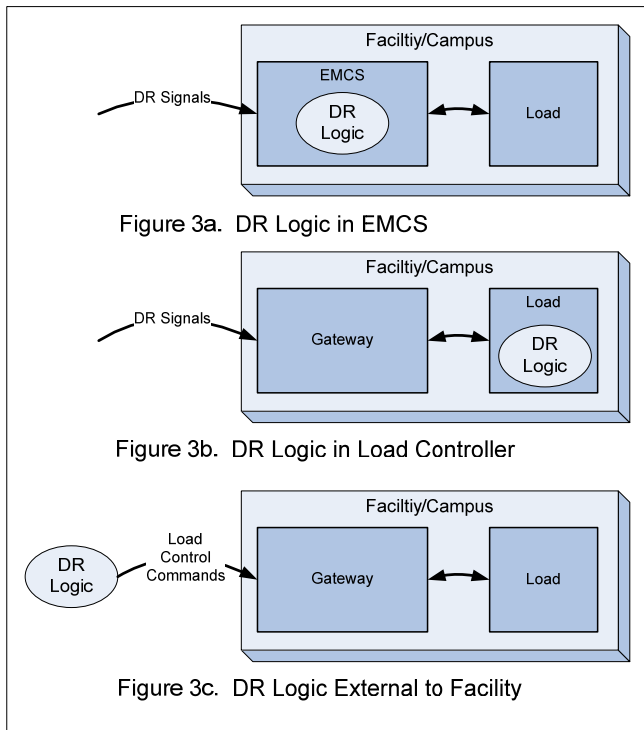

3. THIRD PARTY INTERMEDIARIES

There are a number of organizations that may send signals to the facility and play a role, either directly or indirectly, in how the loads within a facility are ultimately controlled in response to a DR Event. Each of these parties are depicted in Figure 4 and discussed in more detail below.

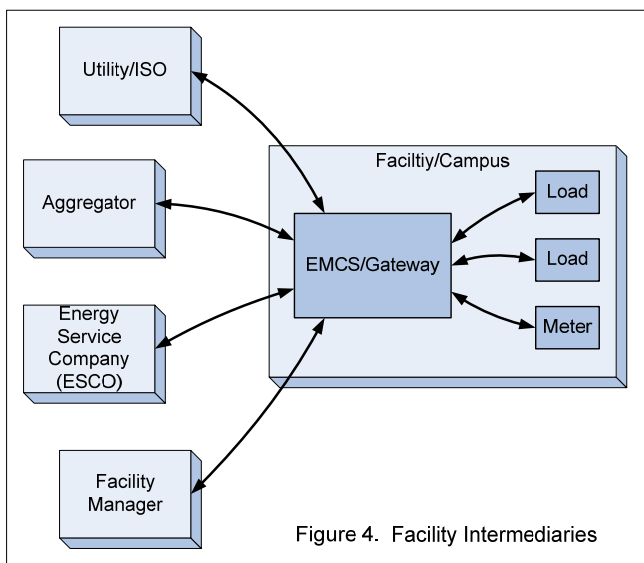

The categories of intermediaries are meant to highlight differences between the type of business relationships the intermediaries have with the Utility/ISO and the end use facility. It is that relationship that dictates how the intermediary will try to influence the load profiles of a facility and thus where they may implement the DR Logic. Each of the entities described below have different motivations for controlling the loads within a facility and thus may take different approaches in both how and where the DR Logic for a facility is implemented. As we saw in the previous section, this may have an impact on the nature of the signals received by the facility. It should be noted that the discussion below for each category of intermediary is meant to give a prototypical scenario and is not meant to imply that all intermediaries of that type operate in the manner described.

3.1. Utility/ISO

The Utility/ISO is one example of an organization that is the source of DR Event signals. In some DR programs the Utility/ISO performs what is called Direct Load Control as shown in Figure 5.

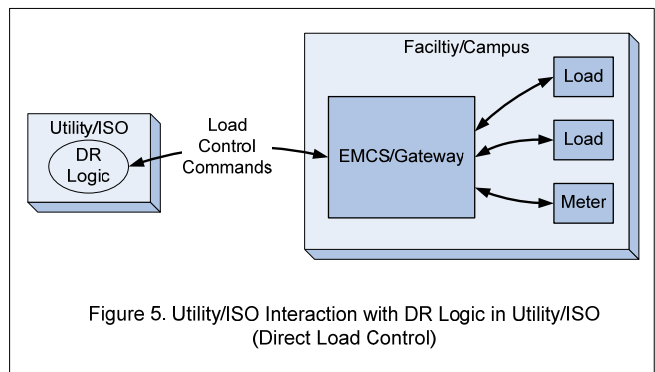

Direct Load Control essentially means that the DR Logic is implemented at the Utility/ISO and DR signals are sent to the facility which results in specific loads being controlled in a fairly specific fashion. The advantages of Direct Load Control are that it can result in a predictable response. The down side is that there is little or no flexibility in the load response and there is little or no customer choice in how the facility responds. Furthermore even if there were a standardized way to send load control signals to the facility it would not alleviate the need for the Utility to maintain a model for the loads in each facility and how they are to be controlled. In order to make that feasible the Utility/ISO can only deal with fairly simple and fixed types of loads.

A more flexible approach that allows a wider range of facilities and loads to participate is for the Utility/ISO to send a DR signal that contains business level information (i.e. price or reliability information). These signals allow a facility manager to choose how to implement the DR Logic that determines how the loads will respond. This is depicted

in Figure 6. The advantage of this approach is that the Utility/ISO can publish the DR signals using business logic that directly relates to the conditions on the grid that define the DR Event period. Since it doesn't need to control specific loads it can do this in a fairly standardized fashion and allow the facility to decide how its loads will respond to this information.

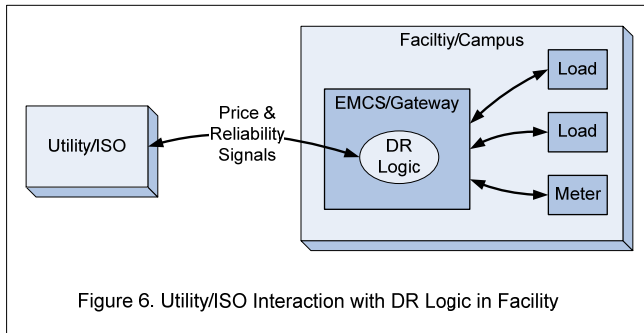

Figure 6. Utility/ISO Interaction with DR Logic in Facility

3.2. Aggregator

An Aggregator is a third party entity whose objective is to aggregate the loads of multiple facilities from different customers and have them behave as a single load to the Utility/ISO as depicted in Figure 7. They can receive standard business level DR signals from the Utility and then implement some sort of aggregated DR Logic across all the facilities in their portfolios. Since their objective is to spread the DR response among several different facilities in a manner which best suits their business objectives, it is not necessarily in their best interest to simply pass on the DR signal from the Utility/ISO directly on to their customers. They may instead either pass on some modified form of the general DR signal or in many cases perform direct load control with their customers.

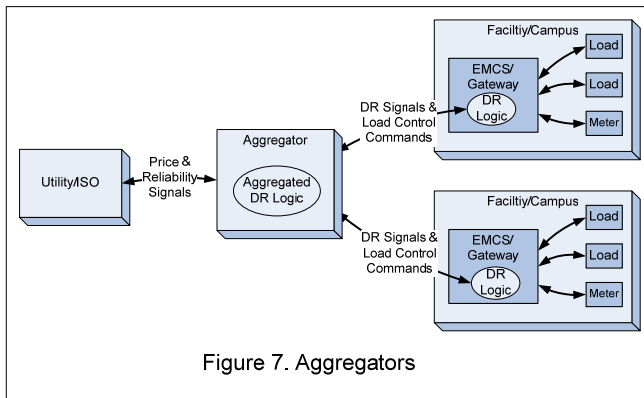

Figure 7. Aggregators

If the aggregator is performing direct load control then clearly the signals they send to the facilities will not be the same form as the DR signals they receive from the Utility/ISO. On the other hand if they pass on price and reliability signals much like they might receive from the Utility/ISO then the DR signal sent to the facilities may

have the same form, but may differ in the content depending upon how the aggregated DR Logic determines a specific facility should respond.

3.3. Energy Service Company (ESCO)

ESCO's provide a broad category of services to facilities, all centered on managing some aspect of the energy consumption of the facility. As shown in figure 8 they can act as an intermediary to receive standard business level DR signals from the Utility/ISO and use that information to manage facilities energy consumption. Their objectives are different from Aggregators in that they are more interested in load shaping (or load management at an individual facility while Aggregators are interested in delivering DR across multiple facilities.. Because of this difference they will either perform direct load control on the facilities or simply pass on the DR signal that was received from the Utility/ISO. It is unlikely they would modify the signal the way an Aggregator might since they are not trying to aggregate loads.

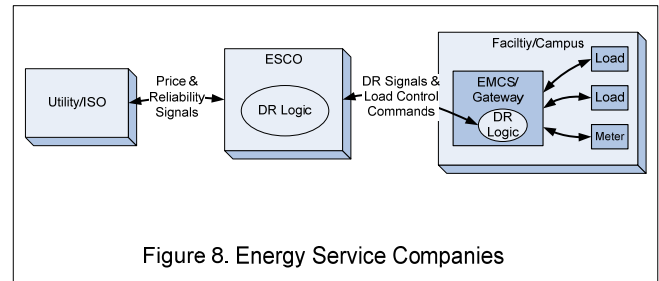

Figure 8. Energy Service Companies

3.4. Remote Facility Energy and Asset Manager

As shown in Figure 9 a Remote Facility Energy and Asset Manager can be a remote owner or a third party controls or service company that may be an intermediary between the Utility/ISO and the facility.

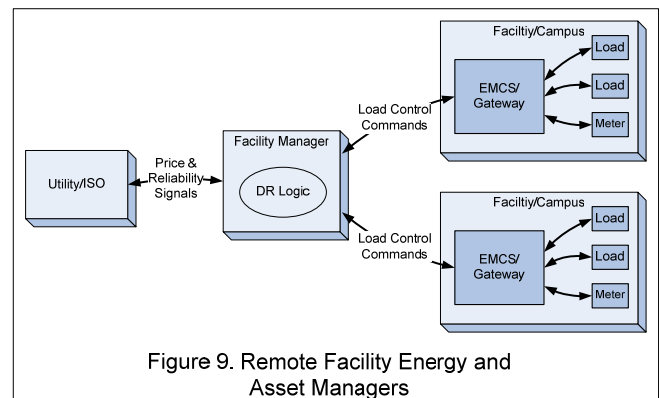

Figure 9. Remote Facility Energy and Asset Managers

They manage operational aspects of a facility from a control system point of view. Big box retail and chain businesses with many geographically dispersed facilities will hire these types of entities to manager all their facilities. Managing

energy consumption would be one of the operational aspects of a facility that would be under the responsibility of a Facility Manager entity. They are focused on the response of individual facilities and are typically not concerned with aggregating loads.

They typically manage all the controls of a facility from a centralized location and as such the nature of the signals they would most likely send to the facility would be of the form of load control commands. In this scenario the DR Logic for a particular facility would therefore be implemented at the Facility Manager site and not within the facility.

4. ROLE OF STANDARDS FOR DR SIGNALS

From an industry wide interoperability perspective perhaps the most desirable form of a DR signals are for the Utility/ISO to publish a set of standardized signals that contains business level information such as prices and reliability information. A standardized DR signal of this type can allow all of the various participants and intermediaries outlined in section 3 to utilize the DR signals from any Utility/ISO. The fact that the DR signals contains business level information as opposed to direct load control commands allows for a wider range of participants to utilize the signals and gives them more flexibility in determining how they will respond. This is crucial in satisfying the requirement for “customer choice” in DR programs.

An example of one such possible standard for this type of DR signaling is that presented in the proposed OpenADR standards under development by the Demand Response Research Center of Lawrence Berkeley National Laboratory.

As outlined in section 3.1 there is a need in some use cases for the Utility/ISO to communicate standardized DR signals directly to a facility. Therefore, there is also a need for EMCS/controls vendors to adopt a common DR signaling standard so they may participate in these type of programs.

In many of the scenarios outlined in section 3 there are legitimate use cases where it is necessary to perform direct load control between the intermediary and the facility. In those cases the DR Logic is implemented within the intermediary and translated into the necessary load control commands sent to the facility. It is also important to note that in some cases the intermediary is not sending direct load control commands, but instead sending the same type of business level information that might be found in the DR signal that was originally sent from the Utility/ISO. In these cases the same DR signal standard that was used by the Utility/ISO to originally publish the DR signal could be used to send the DR signal to the facility by the intermediary. This would allow the controls vendors to leverage the same development money they spent to receive

the DR signals directly from the Utility/ISO to also receive them from intermediaries.

It is also important to note that in many cases the Utility/ISO will pay facilities large sums of money to enable them to participate in their DR programs and as such they would like to make sure that they are not creating so called stranded assets by enabling a proprietary infrastructure such as might be used by an Aggregator.

Figure 10 shows an architecture wherein standardized DR signals may be used in conjunction with the proprietary infrastructures of various intermediaries. In essence the objective is that whenever a facility is utilizing a DR signal that contains the same type of business level information that was originally published by the Utility/ISO they should use the same standard that was used by the Utility/ISO for the signals they publish regardless of whether that signal is being sent to facility from the Utility/ISO or an intermediary. This allows controls companies to build products that can participate in the widest range of DR programs and avoids stranded assets.

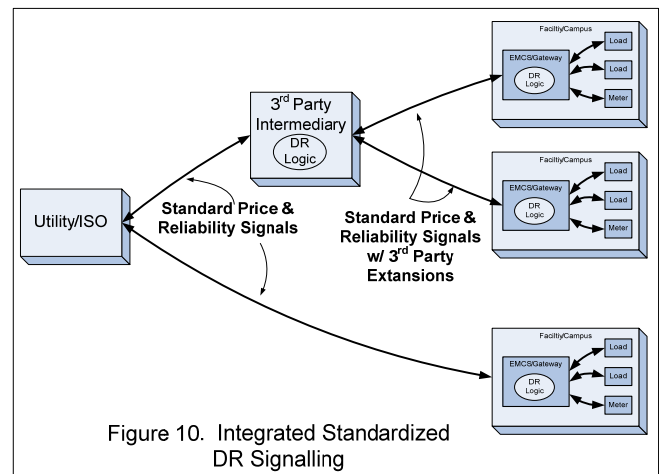

It should be noted that this does not preclude the intermediaries from implementing some sort of proprietary signaling to satisfy their own business objectives and technologies. The proposed OpenADR signaling standard allows for just these sorts of proprietary extensions.

5. NATURE OF STANDARD DR SIGNALS

In this section we start with the assumption that the DR Signals that are being consumed by the various participants should contain business level information as opposed to direct load control commands as described in previous sections of this paper. This gives the maximum amount of flexibility to the participants that are consuming the DR signals. This type of information also better reflects the conditions on the grid that caused the DR Event to occur.

Furthermore since this paper focuses on Automated DR it should be noted that the DR signals are consumed by other computers, automation systems, and possibly end device load controllers. That dictates that the DR signal satisfy the following requirements:

- It should use standardized forms of representation (i.e. XML) to allow the widest range of existing development tools to be used to program the devices consuming the signals.
- The schema used to encode the information in the DR signal should be simple enough to allow lower end devices to process it.
- The complexity of the information should be such that simple rules can be devised by non-IT professionals (i.e. facility managers) to allow the DR Logic to be specified.
- The DR signal should be designed such that it can be delivered using widely deployed networking infrastructures such as IP networks and Web Services. Where applicable it should also comply with existing end device communications standards such as BACnet, OPC, oBIX, IETF, etc. This will allow for the widest range of end devices to consume the DR signal.
- The DR signal should be designed so that it can be delivered in a secure and non-repudiated fashion.

The above are cross cutting issues that define the constraints on how the DR signal is represented, independent of the type of information contained in the DR signal.

In general a standard DR signal should contain the following categories of information:

1. **DR Event information.** This is the actual business level information that is related to the DR Event. As already described, the nature of this information is dependent upon the DR program and how it is being managed and includes many different types of information. In some cases it may be prices and in other cases it may be shed levels, among other things. A standardized DR Signal needs to be able to accommodate the different types of information that may be used.
2. **Schedule of DR Event and business information.** This is a date and time that specifies when the DR Event is occurring and when the information related to the DR Event is valid. It may be as simple as a single calendar event or it may be a more complicated schedule which specifies when different pieces of information are valid. An example might be a schedule of prices wherein

different time slots during the DR Event period represent different prices.

3. **Ancillary information.** This is information that may aid the DR Logic in determining how best to respond to a DR Event. An example of this type of information includes grid reliability, source of energy (i.e. green power), etc.
4. **Intermediary specific information.** This allows for third party intermediaries to embed information within the DR signal that may be used to satisfy their specific objectives as outlined above.
5. **Simplified DR Event representation.** This is an alternative (i.e. simplified) representation of the DR Event information that allows a wider range of automation systems and load controllers to consume DR Events and respond to them.

With regards to item 1, a standardized DR signal should be harmonized with other standards (e.g. IEC 61850) that may also be standardizing the same types of information. An example is price information for which there currently does not exist a widely adopted standard, but when one is designed it should be utilized.

With regard to item 2, it is commonly recognized that there is a need for a standardized representation of schedules other than for the purposes of DR. Standards such as iCAL could play a role in defining the schedules in DR signals.

With regard to item 4, this paper identifies legitimate business reasons why third party intermediaries may want to control facilities in some proprietary fashion. Nonetheless there are other use cases that require the facilities to receive standardized DR signals directly from the Utility/ISO. Thus the vendors of control systems may be faced with investing development dollars into multiple means of receiving DR signals. A rational approach to minimizing this problem is to adopt standardized DR signals that everyone can adopt while allowing for the signals to be augmented in some fashion so that they can be used to satisfy the particular needs of some third party intermediary.

With regard to item 5, the type and complexity of the information sent as part of a DR signal can be quite varied and complex. Although this will allow a wide range of responses it also makes the task of consuming the DR signal quite complex. This is difficult to do for most existing automation systems and load controllers. Therefore also having a simplified representation of the DR Event can simplify the task of consuming the DR signals for these devices. Work at the Demand Response Research Center of Lawrence Berkeley National Laboratory has demonstrated that using a simple shed level representation

such as “moderate” and “high” can be effectively used to allow the controllers within facilities to respond to DR Events without having to parse and interpret much more complicated information such as price schedules. The more complex information (i.e. prices) that are part of the DR signal can be mapped to these simple levels prior to the signal being sent to the facility. Having both a more complex and simple representation of the information within the DR signals allows the maximum range of devices and systems to respond to the DR signal.

All the requirements given above formed the basis for the specification of the DR signal in the proposed OpenADR standard.

6. ACKNOWLEDGEMENTS

This work was sponsored by the Demand Response Research Center which is funded by the California Energy Commission (Energy Commission), Public Interest Energy Research (PIER) Program, under Work for Others Contract No.150-99-003, Am #1 and by the U.S. Department of Energy under Contract No. DE-AC02-05CH11231.

References

(Piette et al. May 2007) Open Automated Demand Response Communication Standards Public Review Draft 2008-R1, Available at www.OpenADR.org.

Koch, E., Piette, M.A., Architecture Concepts and Technical Issues for an Open, Interoperable Automated Demand Response Infrastructure. Presented at the Grid Interop Forum, Albuquerque, NM, November 7-9, 2007. LBNL-63665.

(Piette et al. 2007) Piette, M.A., S. Kiliccote and G. Ghatikar. Design and Implementation of an Open, Interoperable Automated Demand Response Infrastructure. Presented at the Grid Interop Forum, Albuquerque, NM, November 7-9, 2007. LBNL-63665.

Motegi, N., M.A. Piette, D.Watson, S., Kiliccote, P. Xu., Introduction to Commercial Building Control Strategies and Techniques for Demand Response. LBNL Report 59975. May 2007. Available at drcc.lbl.gov.

M.A. Piette, D.Watson, N. Motegi, and S., Kiliccote. Automated Critical Peak Pricing Field Tests: 2006 Pilot Program Description and Results. LBNL Report 62218. May 2007. Available at drcc.lbl.gov.

Piette, M.A., D. Watson, N. Motegi, S. Kiliccote, E. Linkugel. 2006a. Participation through Automation: Fully Automated Critical Peak Pricing in Commercial Buildings. Proceedings of the 2006 ACEEE Summer Study on Energy Efficiency in Buildings. LBNL-60614. August 2006.

(Kiliccote et al. 2006) Kiliccote S., M.A. Piette and D. Hansen. Advanced Controls and Communications for Demand Response and Energy Efficiency in Commercial Buildings, *Proceedings of Second Carnegie Mellon Conference in Electric Power Systems*, Pittsburgh, PA. LBNL Report 59337. January 2006.

Piette, M.A., O. Sezgen, D.S. Watson, N. Motegi, and C. Shockman. 2005a. Development and Evaluation of Fully Automated Demand Response in Large Facilities. Lawrence Berkeley National Laboratory CEC-500-2005-013. LBNL-55085. Berkeley CA, January. Available at drcc.lbl.gov.

Piette, M.A., D.S. Watson, N. Motegi, N. Bourassa, and C. Shockman. 2005b. Findings from the 2004 Fully Automated Demand Response Tests in Large Facilities. Lawrence Berkeley National Laboratory. CEC-500-03-026. LBNL-58178. Berkeley CA, September. Available at drcc.lbl.gov.

Quantum Consulting Inc. and Summit Blue Consulting, LLC. 2004. Working Group 2 Demand Response Program Evaluation – Program Year 2004 Final Report. Prepared for Working Group 2 Measurement and Evaluation Committee. Berkeley CA and Boulder CO, December 21. Available at <http://www.energy.ca.gov/demandresponse/documents/>

Biography

Ed Koch is founder and CTO of Akuacom. Akuacom specializes in enterprise systems for automated energy control and monitoring in commercial and residential buildings, especially as it applies to Demand Response Programs. Prior to that Ed was the founder and CTO of Coactive Networks which specialized in creating solutions for linking distributed control networks used in energy management systems to IP networks and enterprise applications.

Mary Ann Piette is a Staff Scientist at Lawrence Berkeley National Laboratory and the Research Director of the PIER Demand Response Research Center. She has at LBNL since 1983 and has extensive experience evaluating the performance of energy efficiency and demand response in large facilities. The DRRC plans, manages, conducts and disseminates DR research for the California Energy Commission. Ms. Piette has a BA in Physical Science and a MS Degree in Mechanical Engineering from UC Berkeley and a Licentiate from the Chalmers University of Technology in Gothenburg, Sweden.

DISCLAIMER

This document was prepared as an account of work sponsored by the United States Government. While this document is believed to contain correct information, neither the United States Government nor any agency thereof, nor The Regents of the University of California, nor any of their employees, makes any warranty, express or implied, or assumes any legal responsibility for the accuracy, completeness, or usefulness of any information, apparatus, product, or process disclosed, or represents that its use would not infringe privately owned rights. Reference herein to any specific commercial product, process, or service by its trade name, trademark, manufacturer, or otherwise, does not necessarily constitute or imply its endorsement, recommendation, or favoring by the United States Government or any agency thereof, or The Regents of the University of California. The views and opinions of authors expressed herein do not necessarily state or reflect those of the United States Government or any agency thereof or The Regents of the University of California.