

## BEAM BASED MEASUREMENTS FOR STOCHASTIC COOLING SYSTEMS AT FERMILAB \*

Ralph J. Pasquinelli, Valeri Lebedev, Steven J. Werkema, Fermilab, Batavia, Illinois, USA

### Abstract

Improvement of antiproton stacking rates has been pursued for the last twenty years at Fermilab. The last twelve months have been dedicated to improving the computer model of the Stacktail system.<sup>1</sup> The production of antiprotons encompasses the use of the entire accelerator chain with the exception of the Tevatron. In the Antiproton Source two storage rings, the Debuncher and Accumulator are responsible for the accumulation of antiprotons in quantities that can exceed  $2 \times 10^{12}$ , but more routinely, stacks of  $5 \times 10^{11}$  antiprotons are accumulated before being transferred to the Recycler ring. Since the beginning of this recent enterprise, peak accumulation rates have increased from  $2 \times 10^{11}$  to greater than  $2.3 \times 10^{11}$  antiprotons per hour. A goal of  $3 \times 10^{11}$  per hour has been established. Improvements to the stochastic cooling systems are but a part of this current effort. This paper will discuss Stacktail system measurements and experienced system limitations.

### STACKTAIL DESCRIPTION

The Stacktail<sup>2</sup> system (Figure 2) is the largest and most complicated of the nine stochastic cooling systems in the Accumulator. This one system is responsible for taking freshly injected antiprotons and decelerating them to the core while increasing the longitudinal density. Accordingly, the Stacktail system requires a dynamic range in excess of 40 dB as  $2 \times 10^8$  injected antiprotons per pulse every 2.2 seconds yields a core exceeding  $5 \times 10^{11}$  in a few hours. (Figure 1) The front-end pickups have three distinct energy positions which, along with the pre-amplifiers, are cooled to liquid nitrogen temperatures to maximize signal to noise ratio. Three notch filters provide gain shaping and "protection" for the core. The high level consists of eight kicker tanks powered by 32 200-Watt Traveling Wave Tubes (TWT).

### TRANSFER FUNCTION MEASUREMENTS

Transfer function measurements with a network analyzer are made by placing a narrow momentum bite of antiprotons at various revolution frequencies corresponding to the different beam positions of the pickups, (which are located in a high dispersion section of the Accumulator). Of the three pickup legs, the leg at the deposition orbit (leg 1) has the largest number of antennas. The nonlinear beam density profile in Figure 1 is a consequence of the exponential gain profile (Figure 3)

of the Stacktail cooling system. This results in very large gain at all revolution frequencies corresponding to the deposition energy. For this reason, transfer function measurements must be performed with a comparatively small beam current depending on the beam energy to avoid saturation of the front-end preamplifiers. Finding this linear beam current limit took several iterations of transfer function measurements before the maximum beam current for each beam position was determined. In addition to limiting the beam current, the momentum width must also be controlled with the use of longitudinal scrapers or in the case of core and near core measurements, with the 4-8 GHz core momentum cooling. With a large gain slope, a wide momentum profile would provide a different transfer function than a narrow distribution with the same beam current.

To verify the linearity of the results, two sets of measurements were taken. The first set of transfer functions is obtained with the network analyzer in frequency list mode set to harmonics of the revolution frequency (between 1.5-4.5 GHz) of the beam distribution centroid. The network analyzer excites a coherent mode on the beam motion resulting in a response in all three legs (Figure 4). If the excitation and/or beam current are too large, the resulting response may saturate the preamplifiers.

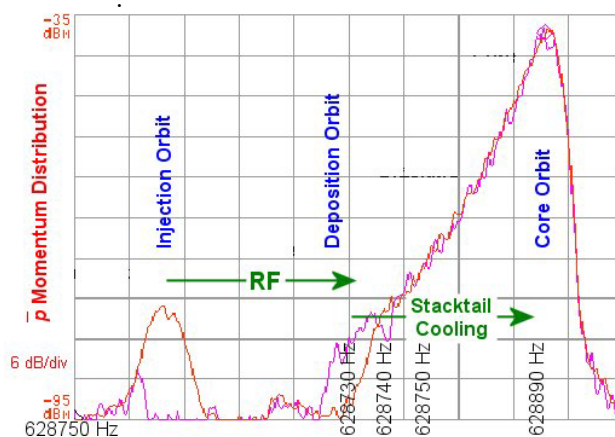

Figure 1: Stacktail Schottky profile vs. revolution frequency. Red trace with freshly injected antiprotons on the injection orbit, purple trace shows remnant antiprotons not picked up by the RF system and the resultant momentum displacement due to the Stacktail cooling.

\*Work supported by Fermi Research Alliance under contract to the US Department of Energy.

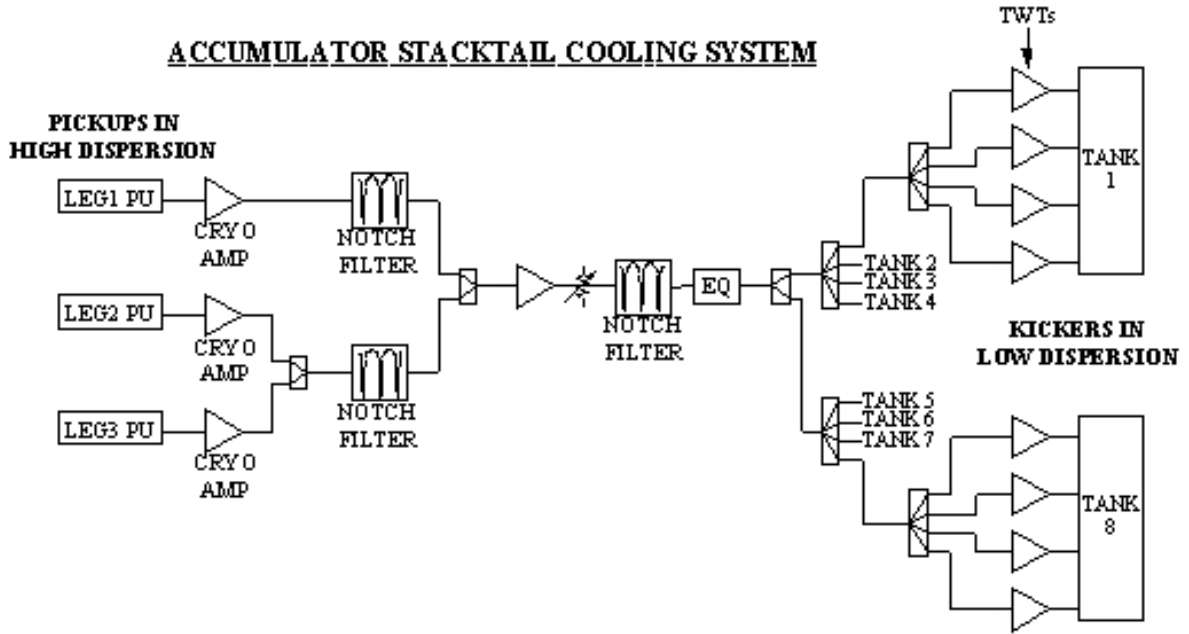

Figure 2: Block diagram of Stacktail cooling system.

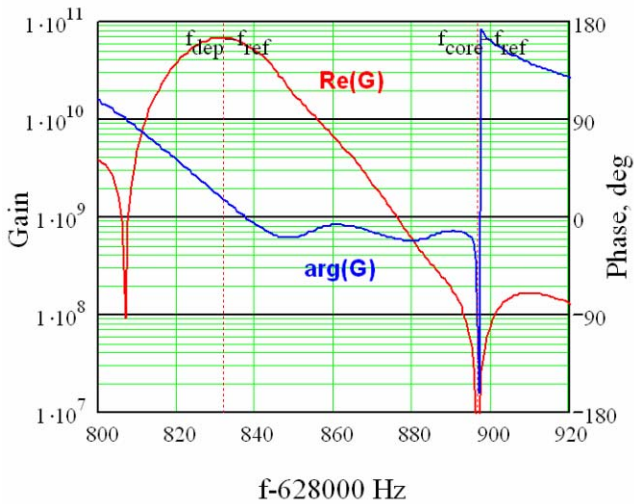

Figure 3: Gain profile of the Stacktail with real part of the gain function and phase as a function of revolution frequency.

A second set of measurements is taken slightly off the central frequency harmonics. For this second measurement, the coherent response of the beam is reduced by some 10-20 dB and shifted in phase by 180 degrees, but remains above the system noise floor. Beam currents were reduced until the ratio of on-resonant and off-resonant measurements were proportional guaranteeing amplifier linearity. All subsequent

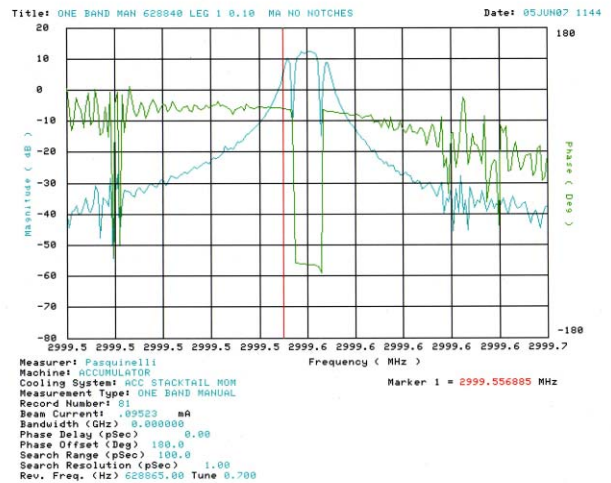

Figure 4: Single Schottky band transfer function measurement. Center frequency is at the beam revolution harmonic, red line marker off resonance frequency. Note 180-degree phase shift along with reduced amplitude response.

measurements are made with this determined beam current and momentum distribution. (Figure 5) An additional cross check with narrow band measurements at different revolution frequencies has also proven beneficial.

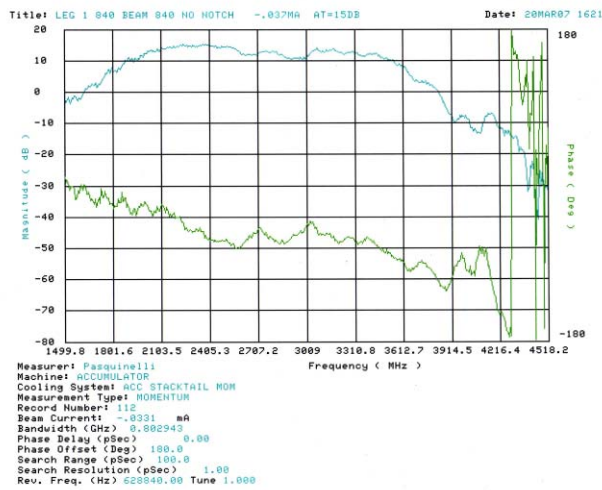
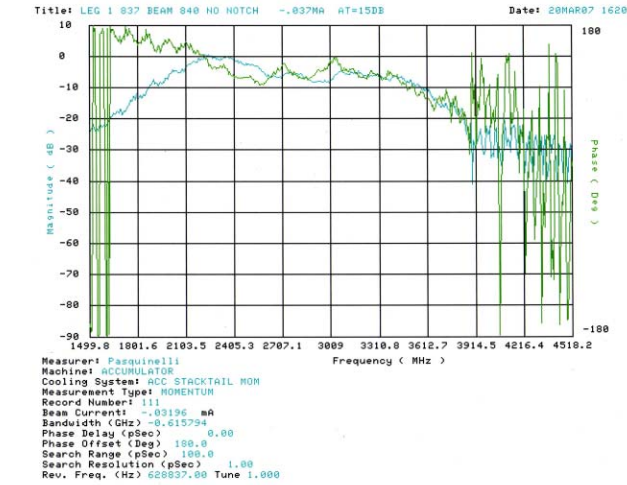

Figure 5: Top transfer function off resonance, bottom transfer function on resonance. Note significant gain and 180-degree phase shift, but there is a proportional relationship between the two indicating no amplifier saturation on resonance.

Notch filters provide rapid gain and phase variations with frequency, which complicates analysis of the measurements. To exclude these complications all measurements were taken with notch filters off (long leg of correlator filters terminated). Notch filters were measured separately and their effect was taken into account in the simulations and system optimization.

To build a Stacktail model, in addition to the measurements of transfer functions, one needs to know dependence of pickup sensitivity as a function of beam energy within each pickup array. It was obtained by measuring Schottky noise in a narrow band (usually a single revolution frequency band at 2.4 GHz) for each pickup array and comparing it to a signal of a 79 MHz Schottky monitor which is located at zero dispersion and therefore does not have direct dependence of the signal on the beam energy. Relating all signals to the first harmonic of revolution frequency and making a square root of

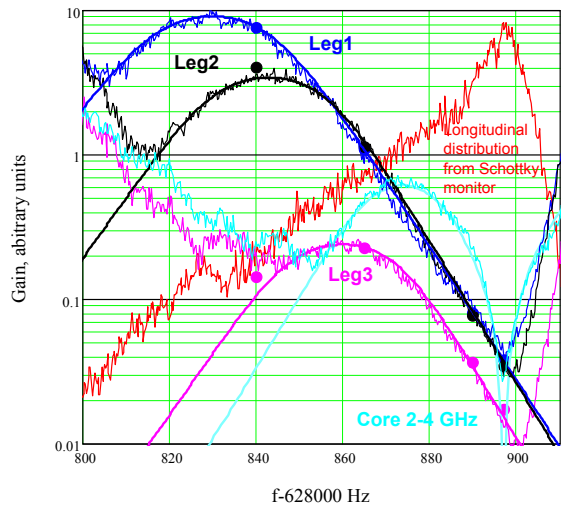
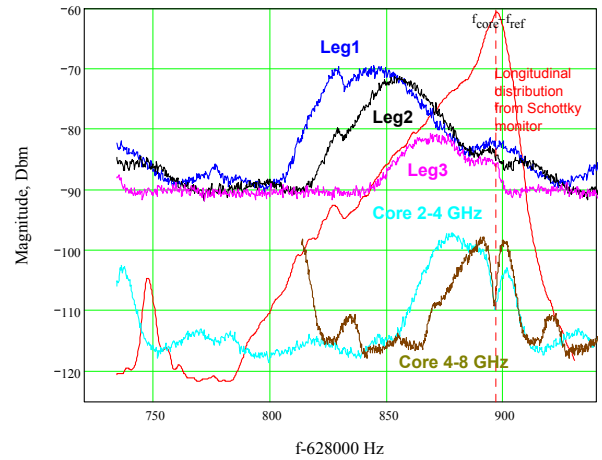

Figure 6: Top shows the Schottky signals from all longitudinal cooling systems in the Accumulator while stacking. Leg 1,2,3 refers to the Schottky signal from each individual pickup of the Stacktail system. Also included is the Stacktail longitudinal profile. Bottom shows the Schottky signals normalized to the distribution profile. The dots are the network analyzer transfer function measurements at various revolution frequencies. The close agreement indicates the transfer functions are truly representative of the system gain, which is most important for the computer model.

signal ratios from a Stacktail pickup and Schottky monitor, one obtains a dependence of corresponding pickup sensitivity on the horizontal particle position within pickup (see Figure 6). To acquire this data all longitudinal cooling systems including the Stacktail have to be stopped to avoid changes of the distribution during measurements. This was verified by acquiring longitudinal Schottky monitor signals at the beginning and at the end of measurements. Automation of the measurements allowed us to reduce time of data acquisition to about 10 minutes. The final transfer function measurements for three different revolution

frequencies as a function of 2-4 GHz system bandwidth is shown in Figure 7.

### SYSTEM LIMITATIONS

Once the transfer functions were understood and faithfully reproducible, these measurements were used to design an equalizer<sup>3</sup> to maximize system performance. The equalizer took two iterations to perfect and did provide improved system bandwidth and phase linearity. The intention was that the equalizer would allow for increasing system gain, hence pushing beam away from the deposition orbit before the next batch arrives.

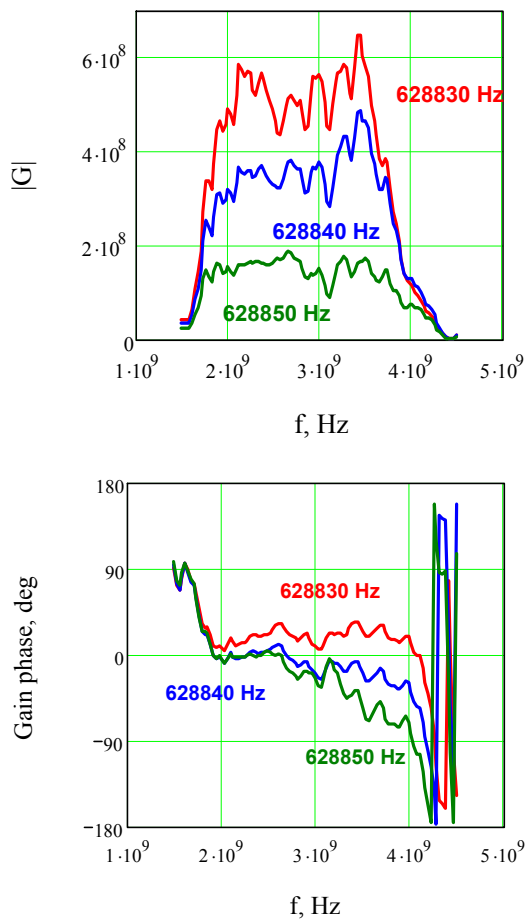

Figure 7: Transfer functions as a function of beam revolution frequency in the 2-4 GHz system bandwidth.

Operational power is 1-2 kilowatts from the 32 installed TWTs with 200-Watts capacity each. This power level is well below the available saturated power, but the TWTs

exhibit significant intermodulation distortion as saturated power is approached.<sup>4</sup> These intermods cause the notches to fill in with uncorrelated noise power that tends to heat the core.

Experimenting with system gain showed that the beam could now be moved from the deposition orbit more quickly but only at the expense of longitudinal core blow up. A new core 4-8 GHz momentum equalizer has been installed to improve that system's effectiveness.

Transverse core heating was also observed with increased Stacktail power levels. This problem was addressed by a lattice redesign<sup>5</sup> that significantly lowered detrimental transverse heating from the Stacktail.

The Stacktail system has a multidimensional tuning space with knobs controlling gain, phase intercept, delay, and notch filter frequencies. This coupled with the fact that the tuning procedure distorts the stack profile makes for a challenging optimization that has been in progress for over two decades.

### REFERENCES

- [1] Valeri Lebedev, Antiproton Production and Accumulation, Proceedings of this Workshop.
- [2] Ralph J. Pasquinelli, Dave McGinnis, Performance of the Upgraded Stacktail Momentum Cooling System in the Fermilab Antiproton Source, Proceedings of the 1993 Particle Accelerator Conference, pages 2361-2363
- [3] Ding Sun, Development and Design of Equalizers for Stochastic Cooling at Fermilab, Proceedings of this Workshop.
- [4] Ralph J. Pasquinelli, Signal to Noise and Dynamic Range Issues in System Design, Proceedings of the 1993 Beam Instrumentation Workshop Santa Fe, New Mexico, AIP Conference Proceedings #319, pages 58-71
- [5] Vladimir P. Nagaslaev, Lattice Optimization for the Stochastic Cooling in the Accumulator Ring at Fermilab, Proceedings of this Workshop.