

HIGH RESOLUTION UPGRADE OF THE ATF DAMPING RING BPM SYSTEM*

N. Terunuma, J. Urakawa, KEK, Tsukuba, Japan

J. Frisch, J. May, D. McCormick, J. Nelson, A. Seryi,

T. Smith, M. Woodley, SLAC, Menlo Park, CA 94025, U.S.A.

C. Briegel, R. Dysert, N. Eddy, B. Fellenz, E. Gianfelice, W. Haynes, D. Nicklaus

P. Prieto[#], R. Rechenmacher, D. Slimmer, D. Voy, M. Wendt, Fermilab, Batavia, IL 60510, U.S.A.

Abstract

A beam position monitor (BPM) upgrade at the KEK Accelerator Test Facility (ATF) damping ring has been accomplished in its first stage, carried out by a KEK/FNAL/SLAC collaboration under the umbrella of the global ILC R&D effort. The upgrade consists of a high resolution, high reproducibility read-out system, based on analog and digital downconversion techniques, digital signal processing, and also tests a new automatic gain error correction schema. The technical concept and realization, as well as preliminary results of beam studies are presented.

MOTIVATION

To achieve a high luminosity in the next generation, linear acceleration-based e^+e^- high energy physics (HEP) collider, low-emittance beam generation and preservation are mandatory. In frame of the *International Linear Collider* (ILC) R&D program, the goal of the beam studies at the KEK ATF damping ring[1] is to generate and extract a beam with an ultra-low vertical emittance < 2 pm [2]. This requires various optimization methods to steer the beam along an optimum (“golden”) orbit with minimum disturbance of non-linear field effects. A high resolution BPM system is one of the important tools to achieve this goal, which requires a resolution in the 100 nm range in a “narrowband” mode.

The “ATF DR BPM Upgrade Project” is a KEK/SLAC/Fermilab collaboration that addresses the problem by installing and commissioning of new hard-, firm- and software for the signal processing to read-out the button type BPM pickups in the ATF damping ring:

- 714MHz-to-15MHz downmix and calibration module (located in the ATF tunnel).
- VME-based digital signal processing and timing electronics, based on the commercial *Echotek* digital receiver.
- Various FPGA-firmware, control and diagnostics drivers and software (C++, LabVIEW, VxWorks, Linux) and an EPICS interface to the ATF control system.

As proof of principle, 20 (out of 96) installed button BPMs are currently equipped with the new read-out system. To minimize the expenses, the experiment is

based on available spare units, rather than implementing the latest generation of digital signal processing technology.

THE ATF DAMPING RING

Figure 1 shows the KEK Accelerator Test Facility with S-Band linac, damping ring and extraction line, as of year 2008. Indicated is the staged upgrade process of BPM stations.

Table 1: ATD DR machine and beam parameters

beam energy E	=	1.28 GeV
beam intensity, single bunch	\approx	~ 1.6 nC $\equiv 10^{10} e^-$ ($\equiv I_{\text{bunch}} \approx 3.46$ mA)
beam intensity, multibunch (20)	\approx	~ 22.4 nC $\equiv 20 \times 0.7 \cdot 10^{10} e^-$ ($\equiv I_{\text{beam}} \approx 48.5$ mA)
f_{RF}	=	714 MHz ($\equiv t_{\text{RF}} \approx 1.4$ ns)
f_{rev}	=	$f_{\text{RF}}/330 \approx 2.16$ MHz ($\equiv t_{\text{rev}} \approx 462$ ns)
bunch spacing t_{bunch}	=	$2/f_{\text{RF}} \approx 2.8$ ns
batch spacing	=	$t_{\text{rev}}/3 = 154$ ns
repetition freq. f_{rep}	=	1.56 Hz ($\equiv t_{\text{rep}} = 640$ ms)
beam time t_{beam}	=	460.41 ms ($\equiv 996170$ turns)
vert. damping time τ	\approx	30 ms
hor. betatron tune (typ.)	\approx	15.204 ($\equiv f_h \approx 441$ kHz)
vert. betatron tune (typ.)	\approx	8.462 ($\equiv f_v \approx 1$ MHz)
synchrotron tune	\approx	0.0045 ($\equiv f_s = 9.7$ kHz)

Table 1 lists some relevant machine and beam parameters of the ATF damping ring. In standard operation a single bunch is injected on axes from the S-Band linac. After ~ 200 ms all injection oscillations are fully damped, and the beam stays for another 400 ms in the ring, before being extracted. Optional multi-batch/multi-bunch operation can be set up on a cycle-by-cycle basis (no extraction), with up to three equally spaced batches, each containing 1...20 bunches, spaced by 2.8 ns.

*This work supported by a high energy physics research program of Japan-USA cooperation, and by the Fermi National Accelerator laboratory, operated by Fermi Research Alliance LLC, under contract No. DE-AC02-07CH11359 with the US Department of Energy.

[#]prieto@fnal.gov

THE ATF DR BPM UPGRADE

the four button-style BPM electrode signals are processed

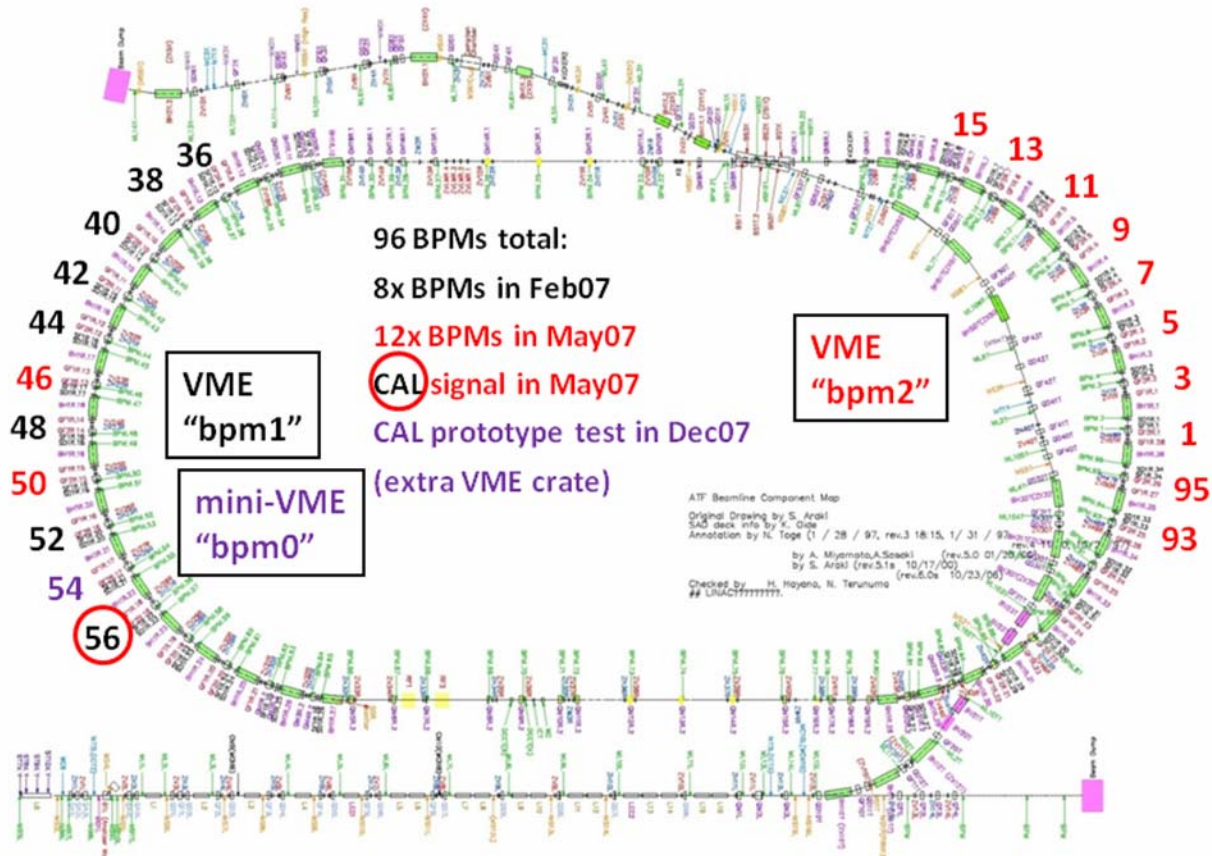

Figure 1: Layout of the ATF damping ring, indicating 20 upgraded BPM stations in the arcs.

A 10-20 μm RMS resolution, measured on the currently installed BPM read-out system, does not meet the requirements for the corrections of non-linear effects in the ATF damping ring, required to achieve the ultimate low vertical beam emittance. A first initiative to upgrade the BPM read-out system was started already in 2006, based on analog downmix modules and commercial *Echotek* digital receivers, achieving 1-2 μm RMS resolution, followed by the 2007/2008 collaboration to the current upgrade status of 20 BPMs:

separately up to the VME CPU, where the actual position normalization and calibration takes place. All analog hardware, i.e. downmix modules and calibration signal generation (under development), is located in the tunnel:

- The **downmix module** receives the four signals from the button-style pickup, filters the 714 MHz frequency content ($\text{BW} \approx 10$ MHz), and down-converts this signal to a 15.1 MHz output signal. The analog signal processing includes low-noise amplifiers in RF and IF sections with switchable gain. A 729 MHz local oscillator signal (LO) generated in the VME timing module is distributed in the tunnel to every downmix modules.
- A **calibration/test signal** is currently in an early development stage. The LO signal is split off and used to locally generate a phase locked test signal of ~ 714 MHz, to be used to observe the long term stability of each analog channel. The signal is close, but not at the 714 MHz readout frequency, but still in the passband of the system. It is injected through a 10 dB directional coupler and couples through the pickup electrodes.

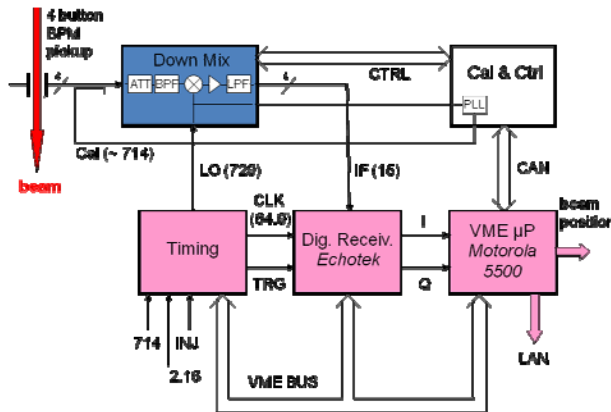

Figure 2: Upgraded BPM hardware.

Figure 2 gives an overview of the new BPM read-out hardware, shown for a single button-style pickup. Each of

All digital hardware is located in two VME crates in the corresponding west and east arc huts, each holds:

- A set of 5 **Echotek digital receiver** modules, each has 8 channels to read-out two BPMs. The Echotek digitizes the 15.1 MHz analog signal at a rate of

69.236 MS/s and downconverts them to baseband. Data filtering and decimation is processed depending on the requested operation mode, e.g. wideband turn-by-turn mode, narrowband mode. The in-phase and quadrature BPM data is stored into the FIFO memory and DMA transferred to the VME CPU controller board.

- A **timing module** generates all required trigger, clock and RF signals, with input signals $f_{RF} = 714$ MHz, $f_{rev} = 2.1636$ MHz and the 640 ms injection trigger. Output signals are $f_{LO} = 729.15$ MHz, $f_{CKL} = 69.236$ MHz (both phase-locked to f_{RF}), and an injection trigger delay able in steps of 2.8 ns.
- A **Motorola 5500 CPU controller** board for data collection and post-processing.

Button-style BPM Pickup

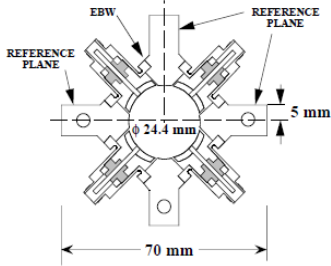

Figure 3: ATF damping ring button BPM.

The ATF damping ring is equipped with a total of 96 button-style BPM pickup stations. The button electrodes are mounted under 45° rotations into the beam pipe of circular cross-section (24.4 mm diameter), to avoid the direct synchrotron light (see Figure 3). The 12 mm diameter button electrodes span $\sim 15.7\%$ (equiv. 56.4°), which results in an electrical beam-to-electrode coupling of $\sim 15.9\%$ for a centered beam.

The highpass-like transfer impedance of the button electrode can be approximated:

$$|Z_b(f)| = \phi R_0 \left(\frac{\omega_1}{\omega_2} \right) \frac{2\pi f / \omega_1}{\sqrt{1 + (2\pi f / \omega_1)^2}} \quad (1)$$

with: $\omega_1 = \frac{1}{R_0 C_b}$, $\omega_2 = \frac{c_0}{2r}$, $\phi = \frac{r}{4b}$

$C_b \approx 5$ pF (button capacitance),

$R_0 = 50 \Omega$ (load impedance),

$b = 12.2$ mm (beam pipe radius),

$r = 6$ mm (button radius),

$c_0 = 2.998 \times 10^8$ m/s (speed of light).

which results in $Z_b \approx 0.735 \Omega$ at the operating frequency $f_{in} = 714$ MHz.

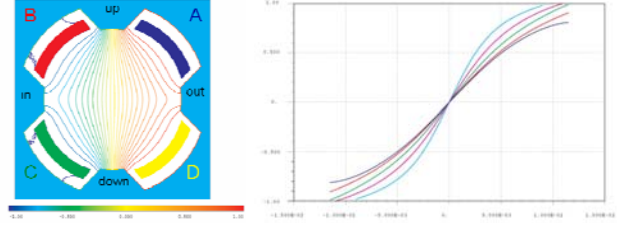

Figure 4: Button BPM characteristics (horizontal).

The position characteristic of the ATF DR button BPM pickup was analyzed numerically by solving the Laplace equation of the pickup cross-section (two-dimensional). Figure 4 (left) shows a corresponding plot of equipotential lines in the form

$$\phi_{hor} = \frac{(\phi_A + \phi_D) - (\phi_B + \phi_C)}{\sum \phi} \quad (2)$$

Figure 4 (right) shows a parametric plot of the horizontal position characteristic for different vertical displacements of the beam. A 5th order 1D polynomial fit of this numerical result $\phi_{hor}(y=0)$, resp. $\phi_{vert}(x=0)$ is implemented in the read-out software for calibration of the BPM pickup signals:

$$Pos[mm] = 9.35 \phi + 1.00 \phi^3 + 7.79 \phi^5 \quad (3)$$

Analog Signal Processing

The analog bandwidth and sampling rate of the analog-to-digital converter (ADC), as well as other hardware specifications, limit the uses of the digital signal processing in the Echotek digital receiver to signal frequencies ~ 40 MHz. The transfer impedance of the button electrodes is poor at frequencies < 100 MHz, thus a higher signal frequency has to be used to ensure a good S/N-ratio. For this reason an analog downconverter, including filters and gain-stages, is inserted in front of the Echotek digital receiver for signal conditioning. Figure 5 shows a simplified block diagram of one (of four) downmix channel. The unit is located in the tunnel close to each BPM pickup station to minimize cable insertion losses. An improved downmix prototype offers a remote controlled step-attenuator between input BPF and LNA, as well as other remote functionality.

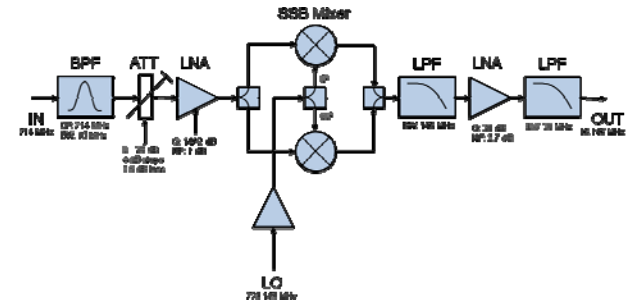

Figure 5: BPM downmix module.

Calibration and Remote Control System

High reproducibility, as well as high resolution is important for the measurements of beam orbits. Uncontrolled drifts in gain stages and RF-switches, filter

components, etc. due to temperature variations or aging effects cause unwanted drifting of the *BPM offset* (according to Eq. (2) and (3)) a 0.1 dB gain error results in a 27 μm offset error). A prototype calibration system was tested separately on BPM #54 with a mini-VME crate, using two (programmable) CW signals 400 kHz off the 714 MHz operating frequency. The signals are generated with a PLL locked to the 729 MHz LO and fed into the system using a 10 DB directional coupler (see Figure 6). The CAL signal transmitted through the BPM pickup, and the reflected CAL signal are detected simultaneously with the beam signal, and processed in parallel in the *Graychip* DDC. The calibration unit also incorporates a CAN-bus based remote control and read-back of various function of the downmix module, e.g. input attenuator, LO-signal level, supply voltages and currents, temperature, etc.

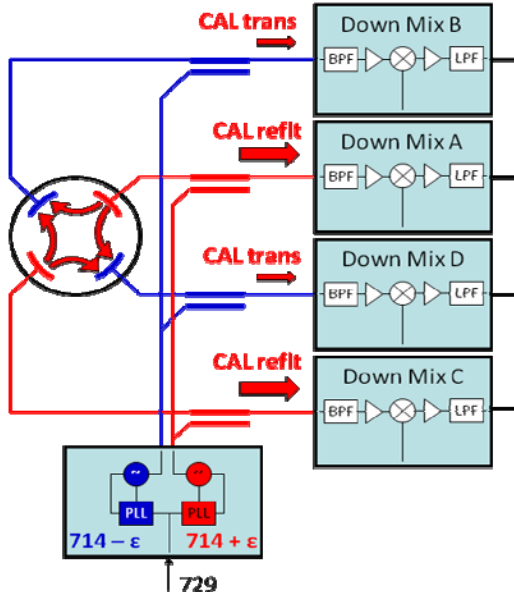

Figure 6: BPM calibration system.

Digital Signal Processing

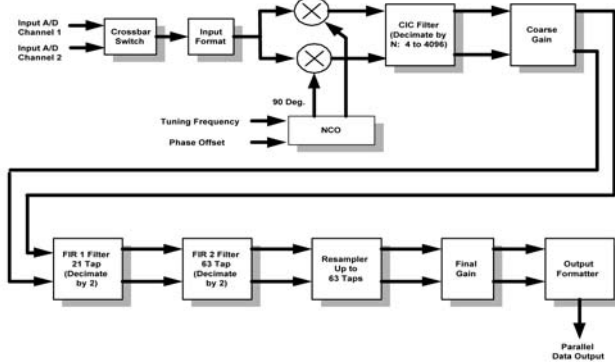

Figure 7: Digital signal processing in the *Graychip* DDC.

Key to the digital signal processing is the 4 channel GC-4016 ASIC (*Graychip*, see Figure 7), which is part of the 8-channel *Echotek* digital receiver VME board. Each signal is digitized at 69.24 MS/s, generating 32 samples / turn. This DDC input data is I-Q demodulated (NCO), low-pass filtered, and decimated using CIC and FIR filters

(see Fig. 7). Further data processing takes place in the front-end hard- and software to produce a final button value computed by taking the square root of the sum of the squares of the I-Q data. This result is used to compute a beam position in combination with three other BPM channels, according to Eq. (2) and (3).

All DDC NCO's are programmed to 15.14545 MHz, shifting the IF frequency to baseband. The CIC and FIR filter coefficients and decimation settings used in:

- **Wideband (turn-by-turn, TBT) mode** (see Fig. 8)
 - 5-stage CIC: decimate by 4
 - CFIR: 7-tap boxcar, decimate by 2
 - PFIR: 1-tap, no decimation
- **Narrowband mode** (see Fig. 9)
 - 5-stage CIC: decimate by 2746
 - CFIR: 21-tap raised cosine, decimate by 2
 - PFIR: 64-tap raised cosine, decimate by 2

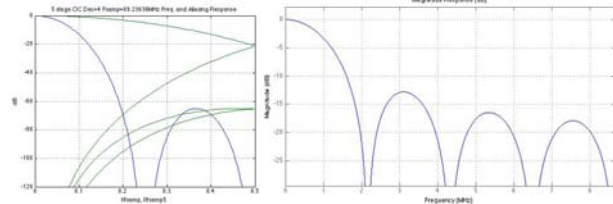

Figure 8: CIC and CFIR filter responses in wideband (TBT) mode, bandwidth \approx 1 MHz.

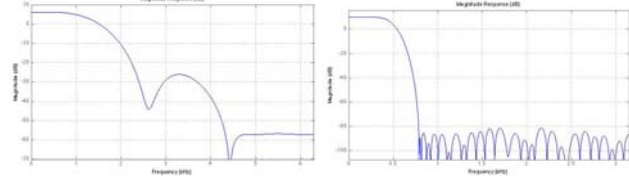

Figure 9: CFIR and PFIR filter responses in narrowband mode, bandwidth \approx 500 Hz.

Auxiliary Hardware

Besides the core components, the BPM upgrade includes power supplies, VME controller (*Motorola* 5500), VME-64 crates, RF-amplifiers, and an in-house developed FPGA-based VME time generator (TGF). The TGF generates all required clock, trigger, and the LO-signal, and also provides programmable delays in steps of 2.8 ns (see Fig. 2).

Software

The layered software isolates components and enables configuration of the system. The software is primarily written in C++. The interface to the digitizer is through a VxWorks driver and functions to optimally control the operation of the board. The ADC class provides a transparent path to the hardware for making measurements. This class is instantiated and invoked by the BPM class. The measurement is controlled with several memory-resident filter specifications and the type of measurement (either diagnostic or a single flash spanning a number of turns.) Timing specifications are set in conjunction with a coordinated trigger for all ATF BPM's. This suite of software provides measurements to a supported LabVIEW client for diagnostics. Turn-by-turn

or closed orbit data is provided to EPICS clients, serving data to the ATF control system.

PRELIMINARY RESULTS

Automatic Calibration System

At BPM #54 an error correction term:

$$X_{corr} = \frac{A_{CAL} + B_{CAL} + C_{CAL} + D_{CAL}}{4 X_{CAL}} \quad (4)$$

is generated from the (transmitted and reflected) CAL tone signal for each channel $X \{A, B, C, D\}$. The correction (4) is added to the measured values Φ_X in (2).

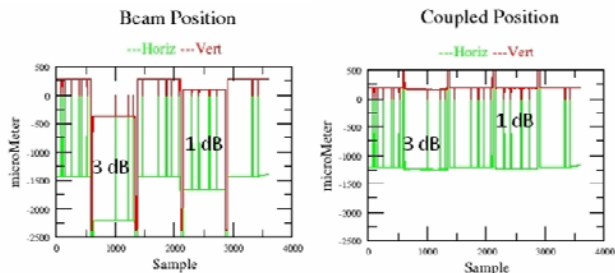

Figure 12: Uncorrected (left) and corrected (right) beam position measurements using the CAL system.

Fig. 11 shows the proof of principle using the automatic calibration correction when introducing a 1 or 3 dB artificial gain error (attenuator pad) in one of the BPM channels.

Narrowband Mode

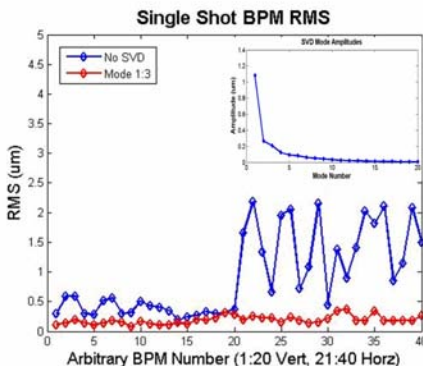

Figure 10: Calculated RMS resolution for the filtered position data, with(out) removing SVD modes.

The obtained narrowband mode resolution was derived using Singular Value Decomposition (SVD) analysis techniques applied to the beam data [3]. For a single injection, the BPM's are triggered at the 500,000th turn and data is collected out of the filter for about 200 ms resulting in 1280 position measurements per BPM at 6.3 kHz. The data is further averaged by a 126 tap box filter specifically chosen to remove 50 Hz harmonics, interfered by the main bus supplies. The resolution is calculated as RMS value on the position data for each BPM, this yields an average BPM resolution of 800 nm. As shown in Fig. 10, the resolutions are much larger for horizontal BPMs.

The SVD technique is applied to the data to remove correlated motion from the BPM data. Just removing modes with strong horizontal correlations yields an average BPM RMS of 200 nm. Other modes show strong correlations in both horizontal and vertical data, but because the SVD modes can mix physical modes, it is difficult to separate beam motion from correlated BPM noise. This analysis requires a good understanding of the machine performance and is still under study. With the machine power supplies off, a signal generator was used in the tunnel to provide a simulated beam signal to the system. A BPM resolution of 30 nm was obtained using the signal generator, giving a lower limit of the achievable narrowband resolution.

Wideband Turn-by-Turn (TBT) Mode

The TBT mode was tested by Fourier analyzing the BPM response to coherent beam oscillations [4], excited by a kicker (pinger) in the horizontal plane, and by missteering the injection in the vertical one. The data quality in the last case is rather poor, since the oscillations lasted only a few hundred turns. The spectral analysis shows betatron and synchrotron tunes, but also unwanted harmonics at lower frequencies, probably due to EMI of the main power bus to the BPM downmix electronics in the tunnel.

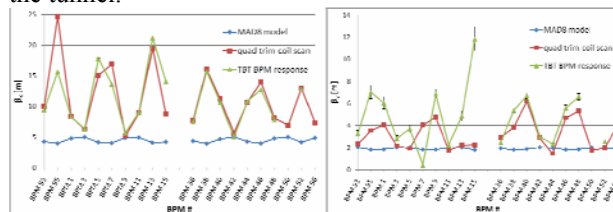

Figure 11: Comparison of measured and theoretical β -functions.

We computed the twiss function values at the BPM locations from the Fourier transform of the TBT oscillations. While the comparison to the model is poor, the results are in good agreement with the betatron amplitudes measured by a scan of the quadrupole trim coils (Fig. 11). The betatron amplitudes computed through the TBT Fourier analysis is determined a constant factor apart, the oscillation amplitude. In Fig. 11 such scale factor was computed by fitting to the data measured by the quad trim-coil scan. TBT response data points are missing at BPM #50 and #56 due to defect electronics channels.

REFERENCES

- [1] J. Urakawa, PAC'97, Vancouver, B.C., Canada, May 1997, pp. 444-448.
- [2] Y. Honda, et.al., Phys. Rev. Lett. 92, 054802 (2004)
- [3] C. Wang, et.al., PAC'01, Chicago, IL, U.S.A., June 2001, pp. 1354-1356.
- [4] J. Borer, C. Bovet, A. Burns and G. Morpurgo, EPAC'92, Berlin, Germany, March 1992, pp.1082-1084.

