

Glass Furnace Model (GFM) Development and Technology Transfer Program Final Report

Energy Systems Division

About Argonne National Laboratory

Argonne is a U.S. Department of Energy laboratory managed by UChicago Argonne, LLC under contract DE-AC02-06CH11357. The Laboratory's main facility is outside Chicago, at 9700 South Cass Avenue, Argonne, Illinois 60439. For information about Argonne, see www.anl.gov.

Availability of This Report

This report is available, at no cost, at <http://www.osti.gov/bridge>. It is also available on paper to the U.S. Department of Energy and its contractors, for a processing fee, from:

U.S. Department of Energy

Office of Scientific and Technical Information

P.O. Box 62

Oak Ridge, TN 37831-0062

phone (865) 576-8401

fax (865) 576-5728

reports@adonis.osti.gov

Disclaimer

This report was prepared as an account of work sponsored by an agency of the United States Government. Neither the United States Government nor any agency thereof, nor UChicago Argonne, LLC, nor any of their employees or officers, makes any warranty, express or implied, or assumes any legal liability or responsibility for the accuracy, completeness, or usefulness of any information, apparatus, product, or process disclosed, or represents that its use would not infringe privately owned rights. Reference herein to any specific commercial product, process, or service by trade name, trademark, manufacturer, or otherwise, does not necessarily constitute or imply its endorsement, recommendation, or favoring by the United States Government or any agency thereof. The views and opinions of document authors expressed herein do not necessarily state or reflect those of the United States Government or any agency thereof, Argonne National Laboratory, or UChicago Argonne, LLC.

Glass Furnace Model (GFM) Development and Technology Transfer Program Final Report

S.A. Lottes and M. Petrick
Energy Systems Division, Argonne National Laboratory

November 9, 2007

Table of Contents

1	Executive Summary	1
2	Background and Objectives	3
2.1	Background	3
2.2	GFM Software Development Program Description and Objectives.....	4
2.3	Technology Transfer Program	5
2.3.1	Technology Transfer Program Description and Objectives.....	5
2.3.2	Technology Transfer Program Status	5
3	The Glass Furnace Model Version 4.0 Technology	7
3.1	Overview of Glass Furnace Model Version 4.0 Computer Software	7
3.1.1	Areas of Major Improvement in Version 4.0.....	7
3.1.2	GFM 4.0 Capabilities.....	8
3.2	Ease of Use and Computer Hardware Requirements.....	9
3.3	Automated Installer Replaces Manual Installation Procedure.....	9
3.4	Graphical User Interface and GFM Control Program.....	10
3.4.1	Simplified User Interface.....	10
3.4.2	Automated File Handling.....	11
3.4.3	New Menu Organization in the User Interface	12
3.4.4	Error Trapping and Warning Messages	12
3.4.5	Furnace Figure and Grid View Environment in Geometry Specification	13
3.4.6	Protecting User Grid Edits While Enabling New Parametric Case Creation Capability	15
3.4.7	Automated Cycling Between Combustion and Melt Space Computations	15
3.4.8	Other Convenience, Performance, and Data Entry Enhancements in the User Interface.....	17
3.5	General Enhancements to the Computational Fluid Dynamics Codes	18
3.6	Combustion Space Model and CFD Code Enhancements.....	20
3.6.1	New Hybrid Radiation Solver.....	20
3.6.2	Automated Soot Model Calibration	21
3.6.3	Other Enhancements in the Combustion Space Model.....	22
3.7	Melt Model and CFD Code Enhancements	23
3.7.1	Melt Surface Heat Flux from Combustion Space Computation	24
3.7.2	Flow Boundary Conditions in the Melt	26
3.7.3	Other Enhancements in the Melt Model	27
3.8	RunPlot Simulation Progress Plotting Program.....	28
3.9	Documentation	30
4	International Commission on Glass Technical Committee 21 Test Case.....	32
4.1	Test Case Included in GFM 4.0 Software Package	32
4.2	Test Case Results and Discussion.....	32
4.2.1	Visualization of Test Results	32
4.2.2	Test Result Summary Data	34
4.2.3	Reporting of Test Results to the IGC TC21 Committee.....	38
5	Availability of the Glass Furnace Model Version 4.0 at Project Completion	39

Appendices

1. GFM 4.0 Tips and Special Procedures.....	41
2. GFM 4.0 Graphical User Interface Menus.....	53
3. Using the GFM 4.0 Graphical User Interface to Build, Run, and Review Models: Two Examples.....	59
4. GFM 4.0 Files.....	74
5. GFM 4.0 Automated Cycling Guide.....	79
6. GFM 4.0 RunPlot User's Guide.....	89
7. International Commission on Glass Technical Committee 21 Round Robin Test 4 and Test 4a Specification.....	95

Glass Furnace Model (GFM) Development and Technology Transfer Program Final Report

Steven A. Lottes
Michael Petrick
Argonne National Laboratory

1 Executive Summary

A Glass Furnace Model (GFM) was developed under a cost-shared R&D program by the U.S. Department of Energy's Argonne National Laboratory in close collaboration with a consortium of five glass industry members: Techneglas, Inc., Owens-Corning, Libbey, Inc., Osram Sylvania, Inc., and Visteon, Inc. Purdue University and Mississippi State University's DIAL Laboratory were also collaborators in the consortium.

The GFM glass furnace simulation model that was developed is a tool industry can use to help define and evaluate furnace design changes and operating strategies to: 1) reduce energy use per unit of production; 2) solve problems related to production and glass quality by defining optimal operating windows to reduce cullet generation due to rejects and maximize throughput; and 3) make changes in furnace design and/or operation to reduce critical emissions, such as NO_x and particulates.

A two-part program was pursued to develop and validate the furnace model. The focus of the Part I program was to develop a fully coupled furnace model which had the requisite basic capabilities for furnace simulation. The principal outcome from the Phase I program was a furnace simulation model, GFM 2.0, which was copyrighted. The basic capabilities of GFM 2.0 were: 1) built-in burner models that can be included in the combustion space simulation; 2) a participating media spectral radiation model that maintains local and global energy balances throughout the furnace volume; and 3) a multiphase (liquid, solid) melt model that calculates (does not impose) the batch-melting rate and the batch length.

The key objectives of the Part II program, which overlapped the Part I program were: 1) to incorporate a full multiphase flow analytical capability with reduced glass chemistry models in the glass melt model and thus be able to compute and track key solid, gas, and liquid species through the melt and the combustion space above; and 2) to incorporate glass quality indices into the simulation to facilitate optimization studies with regard to productivity, energy use and emissions.

Midway through the Part II program, however, at the urging of the industrial consortium members, the decision was made to refocus limited resources on transfer of the existing GFM 2.0 software to the industry to speed up commercialization of the technology. This decision, in turn, necessitated a de-emphasis of the development of the planned final version of the GFM software that had full multiphase capability, GFM 3.0. As a result, version 3.0 was not completed; considerable progress, however, was made before the effort was terminated.

The objectives of the Technology Transfer program were to transfer the Glass Furnace Model (GFM) to the glass industry and to promote its widespread use by providing the requisite technical support to allow effective use of the software. GFM Version 2.0 was offered at no cost on a trial, six-month basis to expedite its introduction to and use by the industry. The trial licenses were issued to generate a much more thorough user beta test of the software than the relatively small amount completed by the consortium members prior to the release of version 2.0.

Eighteen no-cost trial licenses were issued to twelve different companies. The feedback received during interaction with the early trial licensees revealed substantial ease of use issues with the graphical user interface and control program and significant robustness problems in both the combustion space and melt space computational fluid dynamics (CFD) programs of the GFM software package. This result was not unanticipated in view of the fact that the GFM Development Program ended before beta testing of GFM Version 2.0 could be completed.

A review of the feedback from the initial users and the GFM software components yielded a substantial list of improvements to GFM that would be needed to bring the software to a point where a new version could be released that addressed the ease of use and robustness issues. The decision was made to suspend the licensing effort and to develop and implement the necessary improvements. Section 3 of this document describes the major changes and additions to GFM Version 2.0 that were made and that are included in the final GFM Version 4.0. It also includes background information where needed to provide a complete description of the GFM software and to facilitate its use. The appendices include additional information on the components of the technology and guidance on how to use GFM 4.0. The appendices are also included in the software package as user documentation for version 4.0 and are available electronically via the Help Menu while using the software.

Results from initial testing of GFM 4.0 are given in Section 4.0. The test problem chosen simulates hypothetical 20 ton/day and 40 ton/day regenerative glass melting furnaces coupled to the glass melt specified by Technical Committee 21 (TC21) of the International Commission on Glass (IGC). The specifications for these test problems are in Appendix 7. These test cases were chosen as the base cases for testing upgrades in GFM 4.0 because results can be compared with those of other glass modelers from around the world who are members of the TC21 committee of the IGC. The flow patterns, temperature distributions, batch coverage, and other results from the test

problems are within the range of those obtained by other modelers running the test problem.

Version 4.0 of the Glass Furnace Model with the extensive enhancements and model upgrades described in Section 3 and the Appendices has been released. GFM can be ordered via Argonne's Office of Technology Transfer Software Shop web site:

http://www.anl.gov/techtransfer/Software_Shop/GFMSoftware/GFM_Software.html

2 Background and Objectives

2.1 Background

The Glass Furnace Model (GFM) software was developed under a cost-shared R&D program by the U.S. Department of Energy's Argonne National Laboratory in close collaboration with a consortium of five industry members: Techneglas, Inc., Owens-Corning, Libbey, Inc., Osram Sylvania, Inc., and Visteon, Inc. Purdue University and Mississippi State University's DIAL Laboratory were also collaborators in the consortium. The program was initiated in response to competitive and regulatory pressures. The glass manufacturers sought means to improve productivity and product quality, and reduce furnace energy use and emissions.

The GFM glass furnace simulation model that was developed is intended to be a tool industry can use to help define and evaluate furnace design changes and operating strategies to:

- Reduce energy use per unit of production,
- Solve problems related to production and glass quality by defining optimal operating windows to reduce cullet generation and maximize throughput, and
- Make changes in furnace design and/or operation to reduce critical emissions, such as NO_x and particulates.

To meet these needs, the goals of the GFM software analysis tool development were to provide a tool that could be run on readily available commodity computers, that would be as easy to use as possible given the complex analysis task to be accomplished, and that would have sufficient modeling capability to yield the desired useful results from the analysis.

2.2 GFM Software Development Program Description and Objectives

A two-part program was pursued to develop a furnace model that would provide the industry with the desired capabilities. The focus of the Part I program was to: (1) construct and validate a computational fluid dynamics (CFD) based combustion space model that incorporates a direct solve of the radiation heat transfer equation throughout the whole furnace volume using a wide band model for spectral radiation from combustion species such as H₂O and CO₂ and radiation to and from the crown; (2) develop a simulation of the glass melt with Argonne's CFD code which has inherent multiphase flow capabilities and directly incorporate models of the glass batch and foam region; (3) couple the combustion space and glass melt models into a simulation of a selected furnace; (4) make measurements in selected furnaces of key furnace operating parameters to provide a data base for validation of the GFM model; and (5) conduct extensive validation studies of the furnace model. The principal outcome from the Phase I program was GFM 2.0, which was copyrighted. The basic capabilities of the GFM 2.0 code were:

- Built-in burner models that can be included in the combustion space simulation.
- A computationally efficient spectral radiation model that maintains local and global energy balances,
- A multiphase (liquid, solid) melt model that calculates (does not impose) the batch-melting rate and the batch length).

The key objectives of the Part II program which overlapped the Part I program were to (1) incorporate reduced glass chemistry models into the glass melt and thus be able to compute and track key solid, gas, and liquid species throughout the melt; 2) activate the gaseous phase transport equations built into the glass melt model with source terms derived from the chemistry models to compute gaseous species production, bubble nucleation and growth, dissolution, and release from the glass melt surface (foaming); (3) develop and incorporate chemistry and nucleation models of particulate formation for the gases emanating from the glass melt and batch into the combustion space; (4) develop and incorporate glass quality indices into the simulation to facilitate optimization studies with regard to productivity, energy use and emissions, (5) develop and validate furnace simulations of additional furnace types used in the industry, (6) have industry participants evaluate the code by functioning as beta test sites and conducting extensive parametric, sensitivity, and optimization studies of each furnace simulated, and (7) transfer the final version GFM 3.0 along with all data and information generated in the program to the industry.

Midway through the Part II program, however, at the urging of the industrial consortium members, the decision was made to refocus on transfer of the existing code GFM 2.0 to the industry to speed up commercialization of the software technology. A technology transfer program described in the following section was therefore developed and initiated. This decision, in turn, necessitated a de-emphasis of the development of the planned final

version of the GFM code that had full multiphase capability, GFM 3.0. As a result, version 3.0 was not completed. However, limited progress was made in a number of areas: (a) developing glass chemistry models for inclusion in the glass melt code to provide source terms for gas bubbles and hence foam production, (b) bubble transport and surface bursting modules were added to the melt code, (c) development of chemistry and particulate models for products released from the glass melt and batch into the combustion space were initiated; this effort is approximately 50% complete, (d) a module using a Runge-Kutta 4 algorithm for massless particle tracking was implemented in the melt code to form the basis for computing quality indices including residence time, melting index, refining factor, and temperature index.

2.3 Technology Transfer Program

2.3.1 Technology Transfer Program Description and Objectives

The basic objectives of the Technology Transfer program were to transfer the Glass Furnace Model (GFM) to the glass industry and to promote its widespread use by providing the requisite technical support to allow effective use of the software. The project objectives were to be accomplished through the following actions, which were implemented. A brochure was prepared that described the capabilities of the code and the support that would be provided to the user. The brochure was mailed to a broad spectrum of glass industry representatives. The GFM Version 2.0 was placed in Argonne's Software Shop on the internet and was readily available for licensing on-line through the laboratory's Office of Technology Transfer. Technical support was provided to the code users and a GFM software code user group (CUG) was established by setting up a web site where users could report problems and share information on using the software. Every licensee automatically became a member of the CUG and was entitled to receive technical support at no cost throughout the duration of the technology transfer program. The level of support provided was planned to be sufficient to allow the licensee (user) to become proficient in the use of the software. The assumption was that the interested users would devote the necessary time to master the use of the software. Training at Argonne was offered to all new users.

The CUG members were expected to meet periodically to discuss their experience and the results derived from the use of the code. While no formal CUG meetings took place, licensees did provide feedback to Argonne at Glass Manufacturing Industrial Counsel (GMIC) and DOE glass portfolio project status meetings. Further improvements in the software were expected to be part of the technical support activity that would evolve from user feedback and would be incorporated into the software. At the conclusion of this program, the CUG members were expected to define a mechanism that they would implement for provision of any additional support they would need in the long term.

2.3.2 Technology Transfer Program Status

Initially, GFM Version 2.0 was offered at no cost on a trial, six-month basis to expedite its introduction to and use by the industry. The no-fee trial license could be readily accessed on-line from the Argonne Software shop. During the trial period, users were invited to Argonne to learn how to use the software, set up furnace simulations with the graphical user interface (GUI), and evaluate the computational results with the post-processor. The trial licensees were encouraged to apply the GFM software to evaluate and resolve a specific furnace design or operating problem, and thus allow the development team to assess the GFM software Version 2.0. The trial licenses were intended to result in a much more thorough beta testing of the software than the small amount completed by the consortium members prior to the release of version 2.0.

Eighteen no-cost trial licenses were issued to twelve different companies. Staff from eight of the companies received various levels of training on the use of the GFM software. The feedback received during interaction with the early trial licensees revealed substantial ease of use issues with the graphical user interface and control program and significant robustness problems in both the combustion space and melt space computational fluid dynamics (CFD) programs of the GFM software package. This result was not unanticipated in view of the fact that the GFM Development Program ended before beta testing of GFM Version 2.0 could be completed. Also, only one member of the GFM development team could participate in the Technology Transfer program, due to limited available resources, and that engineer left Argonne in the middle of the Technology Transfer program.

Upon the departure of the last GFM development team member, the project was taken over by a CFD development engineer who had a thorough knowledge of the underlying CFD codes. A review of the feedback from the initial users and the GFM software components yielded a substantial list of improvements to GFM that would be needed to bring the software to a point where a new version could be released that addressed the ease of use and robustness issues. The decision was made to suspend the licensing effort and implement the improvements. Section 3 of this document describes the major changes and additions to GFM Version 2.0 that are included in GFM Version 4.0. It also includes background information where needed to provide a complete description of the GFM code and to facilitate its use. Results from initial testing of GFM 4.0 are given in Section 4. The appendices provide additional information and guidance on how to use GFM 4.0. These appendices are also included in the software package as user documentation for version 4.0 and are available electronically via the Help Menu while using the software.

3 The Glass Furnace Model Version 4.0 Technology

3.1 Overview of Glass Furnace Model Version 4.0 Computer Software

The Glass Furnace Model (GFM) Version 4.0 computational fluid dynamics (CFD) and radiation heat transfer computer simulation system computes the reacting gas flow in the combustion space and the particulate solid and liquid melt flow in the glass melt of a glass furnace and couples them through a spectral radiation model to create the overall furnace model. GFM 4.0 is a complete analysis system, including pre- and post-processors. GFM software includes the tools to define the geometry and parameters of a furnace simulation, execute and monitor the progress of the simulation, and visualize the results.

3.1.1 Areas of Major Improvement in Version 4.0

Based upon the feedback received from the initial licensees of GFM Version 2.0, the following areas were identified where significant improvements were needed.

- installation procedure
- ease of use of the graphical user interface and control program,
- robustness and numerical stability of both the combustion and melt CFD programs
- coupling of the two furnace domains
- computational efficiency of the combustion and melt CFD programs,
- efficiency and accuracy of the participating media radiation heat transfer algorithm, and
- summary and convergence data that allow assessment of a simulation.

All of the core package improvement areas have been addressed and greatly enhanced in GFM 4.0. The scope of the changes is quite substantial. The table below gives some hard data relating to the magnitude of the upgrade. It does not include line counts for portions of the software that have been rewritten or counts of extensive comments added to existing lines to make it feasible to maintain the code with much less effort in the future. The number of new executable instruction and commentary lines of code has nearly doubled.

Table 1: Lines of GFM Code

Code	GFM 2.0	GFM 4.0	Growth
Combustion	10956	21728	10772
Melt	11103	16565	5462
GUI	8905	17203	8298
Totals	30964	55496	24532

3.1.2 GFM 4.0 Capabilities

The following capabilities are new in GFM Version 4.0:

- A modern installer, reducing the installation time to just a few minutes without the need to read any documentation.
- A simplified user interface that corresponds more closely to user tasks needed to define a glass furnace and operating parameters for simulation.
- Automated file handling for simulation setup and control. Simulations are now set up as cases, and the user no longer needs any knowledge about file types or file contents.
- Automated cycling between the combustion and melt space computations in coupled simulations. This capability can shrink the time to obtain a converged coupled solution of combustion and melt spaces in a modeled furnace from a couple of weeks to a couple of days.
- A relaxation scheme applied to the coupling conditions between the melt and combustion spaces to damp numerical instabilities in cycling the computation between the combustion and melt.
- A new hybrid radiation computation that greatly improves the accuracy of the wall temperature computation.
- An automated soot model calibration procedure.
- The use of NIST thermodynamic property relations in the gas phase temperature and enthalpy relations.
- A new status monitoring program, RunPlot, that plots convergence measures, average temperatures, and global heat distribution on screen during the course of a simulation. RunPlot makes it easy to see how a simulation is progressing and when temperatures and heat transfer rates have stabilized indicating that the simulation is done. RunPlot also makes it easy to spot problems in a simulation and take steps to correct them.
- Simulation summary files that contain detailed information on global mass and energy balances.
- A large number of other improvements in the models and algorithms.

More detailed descriptions of the technology enhancements implemented in GFM 4.0 are presented in the following sections.

3.2 Ease of Use and Computer Hardware Requirements

GFM has a graphical user interface that provides a straightforward means to build a model of a glass furnace and define material properties and operation conditions by using the preprocessor. In addition, GFM has a post processor that facilitates the display of the simulation results. Use of the software requires an appropriate engineering and glass technology background. Some familiarity with modeling and simulation is also required. Ease of use enhancements are discussed in detail in Section 3.4, which covers enhancements to the user interface and control program.

GFM runs on most currently available computers under the Microsoft Windows® operating system. It has been tested on both Windows®2000 and Windows®XP operating systems. GFM is computationally intensive software that runs single core CPUs at near 100% load. This characteristic may cause overheating if GFM is run on laptop computers. GFM runs best on workstation level computers with 2GB of memory.

3.3 Automated Installer Replaces Manual Installation Procedure

A newly developed GFM installer/uninstaller package replaces the previous manual installation procedure. The automated modern installer reduced the installation time to just a few minutes without the need to read any documentation. The previous manual installation procedure required the user to build a directory structure and populate it with files from the distribution CD. All of the components of the GFM package were incorporated into the new modern Windows® installer interface.

The installer includes an option to install included Visual Basic (VB) 6 runtime files for those machines that require these files to successfully run GFM. License holders will no longer need to buy and install Visual Basic in order to get GFM to run on systems that do not have the Visual Basic 6 runtime files present. The user id and password system that was required whenever GFM was run for the purpose of copy protection has been replaced by a standard serial number system where serial numbers are assigned to licensees, and the serial number is checked at the time of installation. Program and licensee information are also saved in the windows registry upon installation, and this information is checked every time the program is run. The installer automates the installation process, including building and populating the directory structure for the GFM package, creating start menu items, adding an optional desktop icon, and taking the user through pages with the license agreement and copyright notice. The welcome and options pages of the install procedure are shown in Figure 1. The install process is very quick and can be completed in a few minutes.

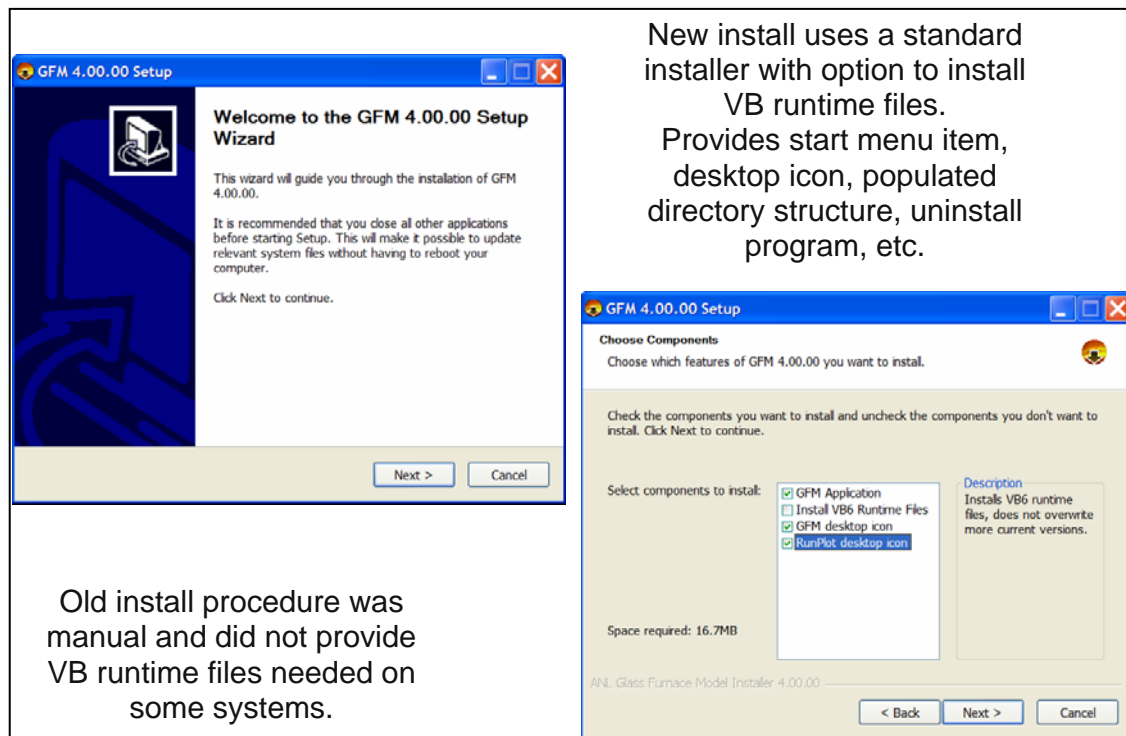

Figure 1. Welcome and component options pages for new modern installer written for GFM

The uninstall program deletes GFM information from the registry and the GFM executable files, but it will not delete user generated case files.

3.4 Graphical User Interface and GFM Control Program

An attempt was made to keep the general “look and feel” of the graphical user interface (GUI) that was familiar to users of previous versions, however many modifications were required. The main GUI changes that improve ease-of-use and support CFD code enhancements are discussed in the following sections. Note that numerous problems and inconsistencies were also corrected, but are not listed here.

3.4.1 Simplified User Interface

The user interface was simplified to correspond closely to user tasks needed to define a glass furnace and operating parameters for simulation. Previously the portions of the user interface used to enter information for a simulation were organized around building the files used by the combustion space and melt space programs. From a user’s perspective, the system to be simulated needs to be defined, then the simulation is performed, and finally results are reviewed. System definition includes specification of furnace geometry, material properties, and operating conditions. Some additional information is also needed such as whether to simulate only the combustion or melt space or to perform a coupled

simulation that cycles between the melt and combustion spaces. The user interface is now organized to make tasks required to define, run, and review a simulation as straightforward as possible.

3.4.2 Automated File Handling

Automated file handling was implemented with a case based setup, control, post processing, and file management scheme. The user's work is now based on simulation cases, and the GFM control program manages the case files. This automation step is very significant because detailed knowledge of the operation of the combustion space code, the melt space code, and the information contained in the various files that they use was needed previously to make decisions about when to load and save files when setting up a simulation within the GUI. The user is now relieved of the burden of needing this knowledge to set up and run a simulation.

Working with cases is very simple. The file menu allows the user to create a new case, delete a case (or only delete the results of running a case), save a case, save a case as a new case (or only save the setup files as a new case), open an old case to continue work on it, and update case descriptions or notes. The "save case as" function provides the user with a means to make a copy of a case (all of the case files are assigned the new case number) that can be used to run a new simulation of the same furnace with one or more operating or geometry parameter changes (Figure 2).

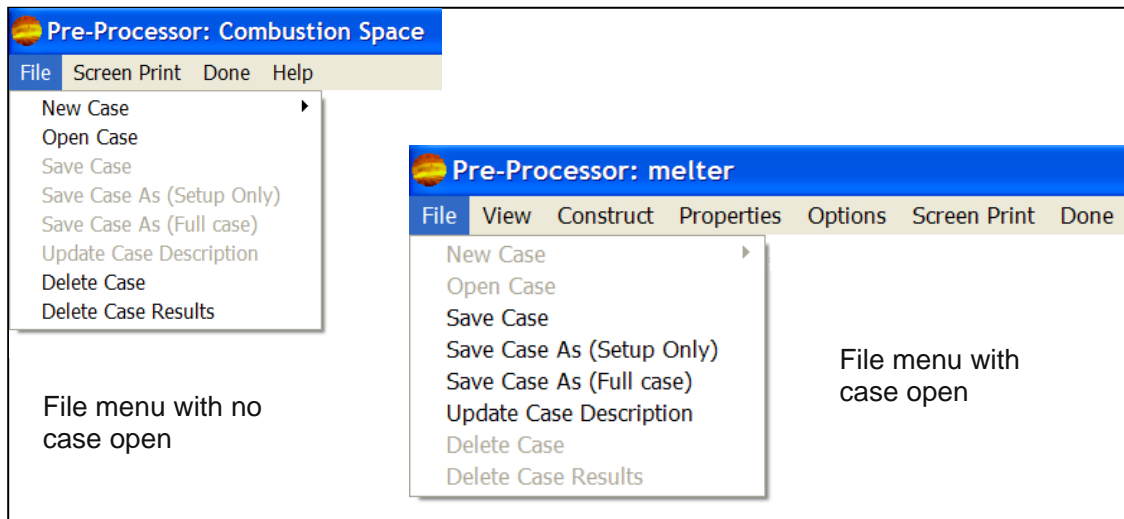

Figure 2. Simplified User Interface with Automated File Handling

Case files are organized in case folders by the user interface and control program. The number of files generated to support a simulation case has expanded greatly. Organizing these case files into separate folders in the directory tree greatly simplifies file organization, providing a simpler interface to cases in menu system and dialog boxes. This file organization is also ideal for users who want to manually copy or backup case

files to other locations or media, such as CD or DVD. Appendix 4 provides a guide to the GFM files.

3.4.3 New Menu Organization in the User Interface

The menu system was restructured to correspond much more closely to the normal user work flow of preparing a case for simulation, running and monitoring the simulation, and reviewing the simulation results. The steps required are described in two examples included in Appendix 3. User actions are clearly segregated into pre-process, simulation, or post-process environments. A menu layer indicator was added to the user interface and control program to allow the user interface to be made context sensitive in a straightforward manner, eliminating many combinations of user inputs that previously led to program lockups.

The menu system was reorganized to bring it more in line with that of a common windows application, improving usability of the program. This effort included:

- Many menu items were renamed to more clearly indicate the function of the menu item.
- Submenu items were removed when their use was not appropriate under the parent menu item. Menu items that are needed under some conditions, depending on the context, are now grayed out and unavailable when their use is not appropriate.
- Some menu items that provided shortcuts between the different work environments or actions that were not related to the tasks in a work environment were removed because they increased the likelihood of software lockups and other serious system errors when the menu item was present for convenience but not needed for functionality.

Appendix 2 describes the menu items, sub-items, and their use.

3.4.4 Error Trapping and Warning Messages

Extensive error trapping and error prevention were designed into the enhanced user interface. Many user errors that previously resulted in abnormal program termination and loss of work are now prevented by various means, such as making actions inaccessible in the menu system under conditions where their initiation leads to inconsistent program states. Invalid user actions are prohibited by graying out and disabling menu items that should not be executed (clicked) at a given point in the user work flow.

Under the philosophy that warning messages improve usability by helping a user avoid mistakes, a large set of error, warning, and information messages was implemented. In particular, a mechanism to notify the user if an action would result in loss of user data

was added. Several examples of warning and information messages are shown in Figure 3.

New routines were added to gracefully close a work environment such as melter geometry and parameter construction, with dialog boxes asking the user if they wish to save the case if changes have been made and the case has not been saved. Similar changes were implemented to the routine that exits the entire GFM application.

The user is warned if they attempt an action that would interrupt simulation or terminate a simulation that is in progress. They are given the option to immediately terminate the simulation, continue to a point where restart files can be saved, or simply to continue.

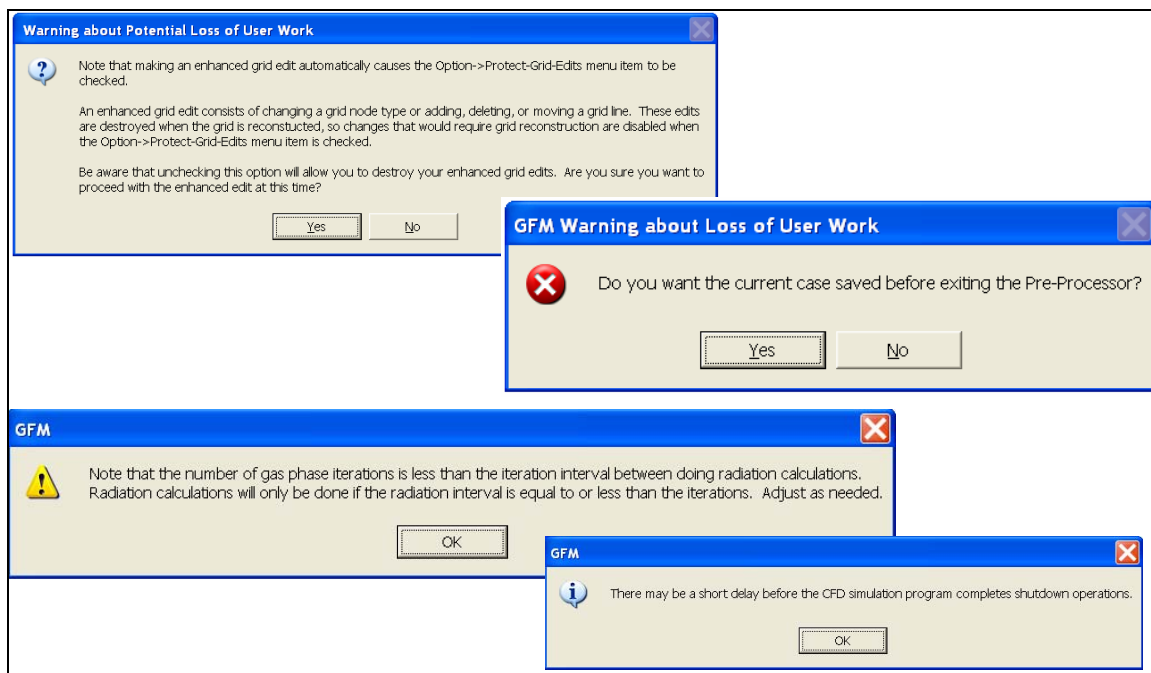

Figure 3. Warning messages improve usability by helping the user avoid mistakes

3.4.5 Furnace Figure and Grid View Environment in Geometry Specification

Functions to enable the user to go back and forth between the figure (schematic) view and the grid view environment were added via a "view" menu item. The figure view environment is used to define the furnace dimensions, position of inlets and outlets, and specify run parameters and physical properties. The grid view environment is used to see and optionally adjust the representation of the figure as a set of discrete computational cells (i.e., the grid) that is passed as input to either the melt or combustion CFD codes.

In addition to convenience (the grid can be reconstructed and viewed as each burner, exhaust, etc. is added), this feature enables the capability to easily create a sequence of parametric runs with varying properties.

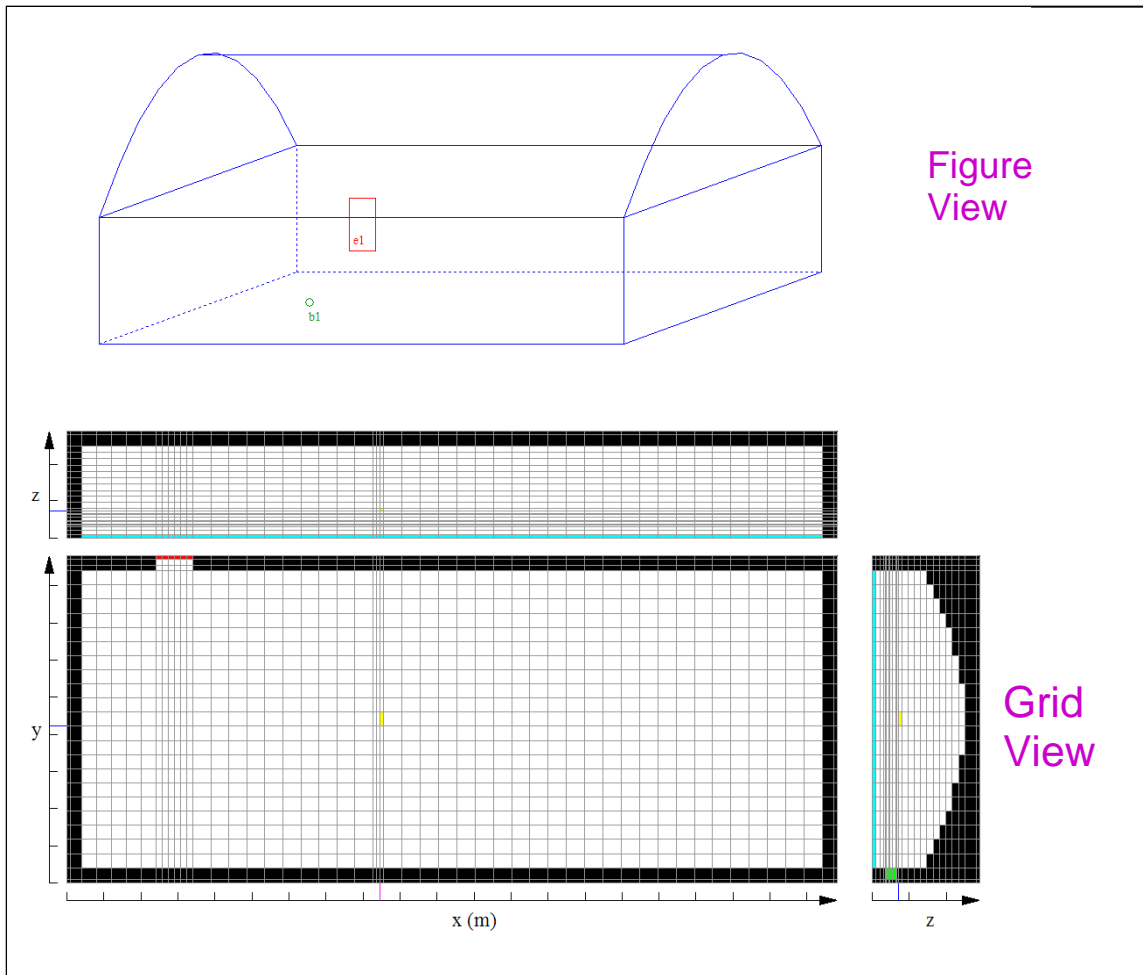

Figure 4. Figure and grid views of default combustion space

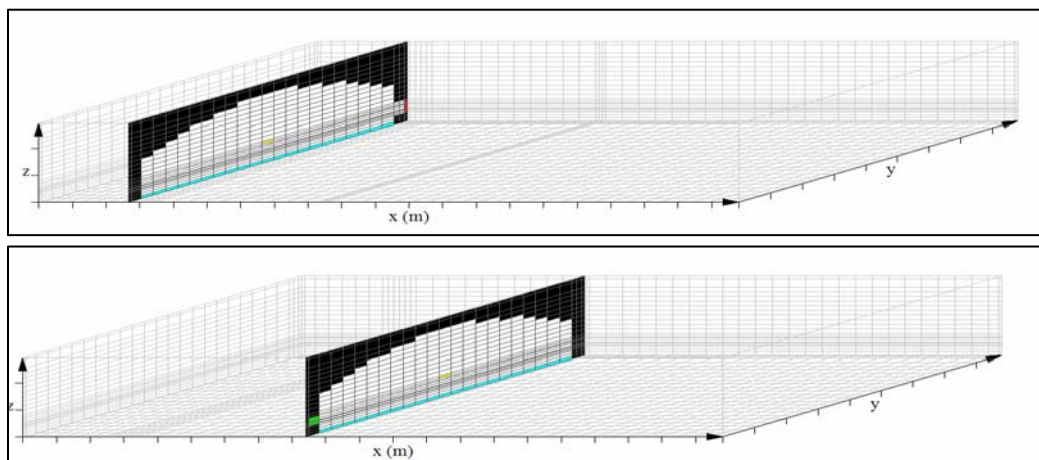

Figure 5. Same grid views in 3D showing exit plane and inlet plane

Figure 4 and Figure 5 show examples of figure and grid views in the combustion space environment.

3.4.6 Protecting User Grid Edits While Enabling New Parametric Case Creation Capability

In GFM 4.0 a series of parametric runs can be done for grids containing user edits (for example one containing user added local refinement around a burner that is not part of the automatic grid generation) without the user having to reapply the grid edits for each case. If a user made hand edits to the grid in the grid view, saved the grid, and ran a case, previously there was no way to start the program up again and make changes to flow rates, inlet temperatures, or other conditions and run the new case without reconstructing the grid, which would destroy any user edits made to the grid.

A mechanism was added to inhibit actions that would require grid reconstruction when a user indicates that they do not want to change their grid by checking menu option “Protect Grid Edits”. When the user makes hand edits to a grid, the grid will automatically be "locked" (put in grid protect mode) with respect to the ability to add or modify objects such as burners in the figure view. However, all the menu items and list boxes that provide access to the various run parameters in the figure view environment are accessible, and any parameter that does not require a reconstruction of the grid can be modified and the case can be run without destroying the user's hand edits to the grid. Thus, for example, a set of parametric runs that investigate the effect of varying relative firing rates among burners can now be easily accomplished for furnace constructions that contain a large number of user edits on top of the automatically generated grid.

The “Protect Grid Edits” menu option can be unchecked to allow the user to unlock a protected grid. However, adding or moving one of the grid objects, such as a burner or exhaust, will require the grid to be reconstructed and any user hand edits will have to be reapplied.

3.4.7 Automated Cycling Between Combustion and Melt Space Computations

An automated control mechanism for cycling the simulation between the combustion and melt space without user intervention was added. This feature allows a tight coupling to be achieved between the combustion space and melt space computations. The melt computation uses the melt surface heat flux from the combustion space computation as its energy boundary condition at the melt surface. The combustion computation uses the melt surface temperature from the melt space computation as its energy boundary condition at the melt surface. The current estimate of the distribution of these values (heat flux or temperature) is exchanged between the combustion and melt space simulation programs at each half cycle transition. The cycling process is illustrated in Figure 6.

Automatic cycling includes the following enhancements to the GFM software package:

- The combustion grids are copied to the melt case directory for use by the melt code to interpolate surface boundary coupling conditions between the combustion and melt domain grids.
- The melt surface boundary condition files are automatically copied between the combustion and melt domain case directories as needed during cycling.
- Information required to control automated domain cycling is maintained in the GUI and control program. Needed communication between the CFD codes and the control program has been added to provide a means to detect completion of a half cycle (i.e., the simulation run for one domain terminated normally with updated surface coupling conditions). When half cycle completion is detected, the control program executes the steps necessary to restart the simulation in the other domain (combustion or melt) with updated glass surface coupling conditions.
- Four cycling submenu items were added under the simulation menu: cycling beginning with the combustion or melt domain first for a regular furnace and second for a regenerative furnace.
- A new dialog box was added that allows cycle control parameters to be automatically changed after the first cycle is complete, with suitable defaults.
- A new status box was added to the display screen to indicate the number of the current cycle, the active domain running, and the cycle status.
- An option was added allowing the user to stop a cycle run after the current cycle has completed. This run termination saves all the files needed to restart the cycle and continue from the cycle where the termination occurred.

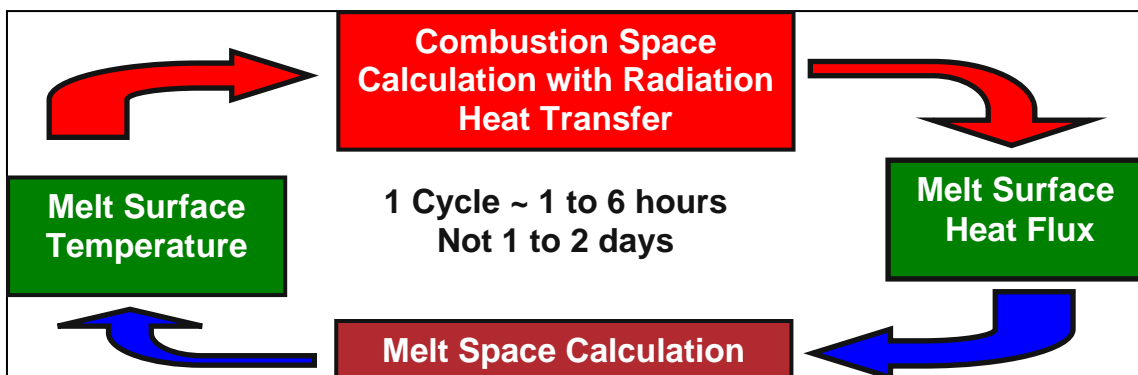

Figure 6. The cycling process

In addition to greatly reducing the work and potential for user error in manual cycling, the greatest advantage in automated cycling is that the time required to complete a

coupled simulation for a moderately sized problem is reduced from about two weeks to about two days. Automated cycling works for both plain and regenerative furnace simulations. Initial experience has shown that 30 or more cycles are needed to obtain a reasonably well converged coupled solution. Completing such a large number of cycles manually is a tedious and time consuming task. Additional description and instructions for setting up automated cycling simulations are found in Appendix 5.

3.4.8 Other Convenience, Performance, and Data Entry Enhancements in the User Interface

In addition to the enhancements in the GFM user interface and control program described in the previous subsections, a large number of other user convenience, performance, and data entry enhancements have been implemented. The most significant of these are listed below.

- Construction of exit tunnels of sufficient length to justify a convection dominated outlet flow assumption at melt exit boundaries was added to the automated grid generation scheme. This technique is often used in CFD computations to achieve stable convergence when recirculation zones may form near a system outlet boundary. In many typical melter geometries, recirculation zones do form near exit planes, and the exit tunnels are needed. Mesh refinement for exhausts and outlets in both the melt and combustion spaces was also added to improve resolution of the flow pattern near exits. The capability to specify parameters for these items was added to provide users the control needed to adjust parameters for difficult to converge cases.
- For software developer convenience a capability to select release or debug mode when building executables was added.
- GFM icons were created for use in the start menu, the Windows[®] taskbar quick launch area, the desktop, etc.
- Mouse handles for moving and zooming the melter and furnace schematic figures were enlarged, and the mouse pointer now changes when the mouse is over the handle to indicate handle function, move or zoom.
- The boundary layer thickness parameter in the model for heat conduction from molten glass to the batch layer on the surface was made user settable.
- The capability to specify batch and cullet inlet velocity was added to the user interface.
- The capability to specify temperature dependent batch and cullet specific heat, via user defined tables, was added.

- Options to specify separate emissivities for crown, walls, and melt surface were added to the user interface.
- An option to enter burner flow rates and fuel heating value in either mass or volume based units was added to the user interface.
- A new dialog box was added to the user interface that allows the user to enter, save, and edit a case description and case notes.
- A new dialog box was added giving the user the option to abort a simulation immediately or to terminate before normal completion, but to delay until a point in the simulation is reached where data for restart can be saved. This option is similar to the one provided to terminate a cycle run at the end of the current cycle, except that it applies to terminating a combustion or melt space computation early (before the maximum number of iterations or convergence is reached) within a cycle.
- The capability to activate the new RunPlot monitoring program from within the GUI was added.
- New menu items are provided for the soot kinetic parameter calibration mode. A message is displayed on the screen indicating when the calibration mode is active.
- The length and width of the main chamber was added to grid files so that CFD codes could reconcile any differences between the melt surface dimensions in the combustion and melt spaces.
- A new dialog box was added to allow the user to specify what status, monitoring, and summary data to collect during simulations.
- New help menu items were added that give the user access to several new documents covering both general and new specific features of the GFM software, such as how to setup and run automatic cycling simulations.

3.5 General Enhancements to the Computational Fluid Dynamics Codes

Some enhancements in the CFD codes are common to both the combustion space and the melt space, although their implementation is different in each space. These common CFD program changes are listed below.

- A computer aided trouble shooting scheme was implemented with data collection and reduction to provide for a means for visual trouble shooting and monitoring the progress of a computation through graphs of mean global variables, such as mass mean temperature over the melt volume or mean exit temperature. The capability to

plot the residuals of the governing partial differential equations versus iteration is provided to allow the user to judge how well converged the solution is and to see the rate of progress toward an adequately converged result.

- Status and trouble shooting data collection and reduction were implemented as optional computations so that the various types of data collection are only done when selectively specified by the user.
- Communications between the CFD codes and the user interface and control program have been enhanced. More user control over the melt and combustion computations was provided via new communications between the GFM control program and the CFD codes as part of the basis for implementation of a cycle convergence control scheme. Timers were added in various CFD code sections to force periodic communication breaks with the GUI.
- Automated cycling between the combustion and melt space computations in a coupled simulation was implemented to provide a major new capability that greatly reduces the time and work involved in obtaining the solution to a furnace simulation in which the combustion and melt space computations are coupled via conditions at the melt surface.
- Most of the models and algorithms were upgraded to address robustness and numerical stability issues in both the combustion space and melt space components. The upgrades were implemented to improve the convergence levels that can be achieved in melt space and combustion space computations in order to make it possible to couple the solution in the two domains and achieve stable convergence in a computation that cycles between the melt and combustion space exchanging values of the coupling variables, temperature and heat flux, at the interface.
- The new automatic cycling capability between the melt and combustion spaces was extended to handle regenerative furnaces. In regenerative cycling mode, a combustion space simulation is run for each of two regenerative burner firing patterns, the heat flux at the melt surface from these alternate firing patterns is then averaged and used as the heat source for the melt computation. The effects of relatively long periods of firing from one set of regenerative burners on batch distribution and melt flow and temperature distribution can still be investigated by running in normal cycling mode.
- Simulation summary files were created that contain detailed information on global mass and energy balances.
- The CFD codes were modified to use files located in case folders.
- Relaxation factors that are used to stabilize numerical solution algorithms in nonlinear systems have been moved to a well commented text file where they can be modified by the user to aid in achieving reasonable convergence for problems that are

very sensitive numerically and do not converge well with the default values of these parameters.

3.6 Combustion Space Model and CFD Code Enhancements

On sample problems the combustion space CFD code of GFM Version 4.0 achieves global and local mass balances to between 3 and 4 significant figures (to within a fraction of a percent or better). Energy balances to about 3 significant figures have been achieved. The main combustion space CFD code changes in GFM are discussed in the following subsections.

3.6.1 New Hybrid Radiation Solver

A new hybrid radiation solver was designed and implemented that greatly improves the accuracy of the wall temperature and melt surface heat flux computation. While a direct solve of the Radiation Transport Equation (RTE) as implemented previously might be considered the best method because it involves minimal modeling, the discretization error in using this method with the limited memory and speed of a single personal computer is significant. Testing showed a very large error in wall temperature prediction for an idealized uniform heat flux case with a known solution.

A new hybrid radiation solver was implemented that splits the direct solve of the RTE into two parts: (1) direct solve of RTE in the volume to get the heat flux from the flame (participating media) and (2) an enhanced wall radiation exchange in an enclosure computation.

The new wall radiation exchange computation is much faster than the previous approach and more accurate by many orders of magnitude for the test problem with known solution. Because heat transfer to the melt is highly sensitive to wall temperature, this new two step radiation solver approach appears to have overcome a major difficulty in achieving adequately accurate wall temperatures. Figure 7 shows a schematic indicating the various heat fluxes that are included in the wall energy balance of the new hybrid wall radiation exchange algorithm. In the figure, $q_{conv,i}$ is the heat flux due to convection from the gas, $q_{c,i}$ is the radiation flux incident on a boundary patch originating from combustion in the volume via the participating media, $q_{amb,i}$ is the heat flux through the wall to the external surroundings, H_i is the radiation flux incident on a boundary patch originating from other boundary patches, ρ is the boundary patch reflectivity, ϵ is the boundary emissivity, and B_i is the radiation leaving a boundary patch (radiosity).

This hybrid participating media and wall exchange thermal radiation computation works well in furnaces where emission from the media is much greater than absorption and the walls can be treated as opaque and gray. These conditions do prevail in a typical glass melting furnace.

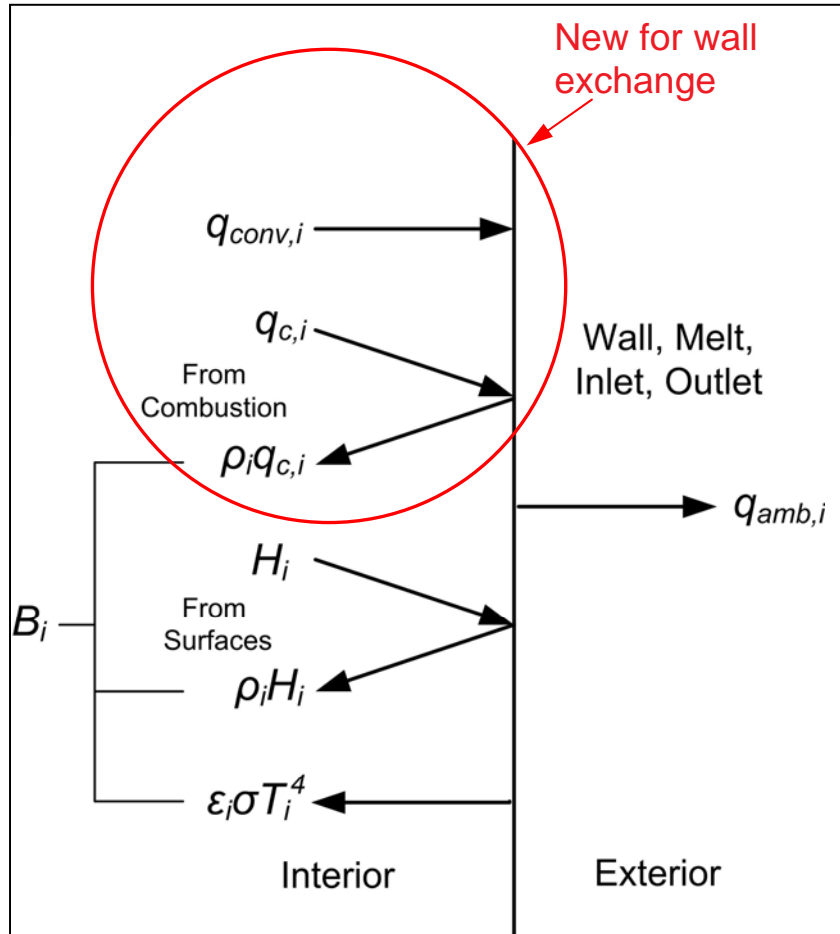

Figure 7. Heat transfer balance at interior wall

The radiation calculation was changed so that emission from the volume would be updated more frequently between full radiation calculations. Calculation of local radiation emission in the volume is a very efficient and fast process and provides reasonably accurate evolution of the radiation heat sink term in the gas phase energy equation when combined with the absorption terms computed in the previous full volume radiation computation. This change greatly reduces the magnitude of combustion space temperature and enthalpy perturbations after a full radiation calculation.

As part of the radiation model upgrade, some user control over the wall exchange radiation computation was added. For example, if the user's computer has sufficient memory, view factors computed from the grid geometry can be saved in memory to speed up the radiation wall exchange calculation, while if computer memory is limited, the user can set an option to recalculate view factors as needed during the computation.

3.6.2 Automated Soot Model Calibration

In air fuel furnace simulations, the radiation heat flux solution is very sensitive to soot production, distribution, and oxidation. To accommodate simulation with the resources of

a PC, a reduced two step soot production and oxidation model is used that has four kinetic parameters. In air fuel furnaces, the magnitude of the total heat flux to the melt is very sensitive to the kinetic model soot parameters, and these parameters may need adjusting for different types of burners, fuel, and furnace geometries.

To provide a means to allow the user to set soot kinetic parameters for furnaces that are significantly different from those used for model validation, a new soot kinetic parameter calibration simulation mode has been implemented. The parameters can be calibrated using operating condition data from an existing furnace or design point conditions for a new design combined with an expected efficiency at the design point. In new designs, the calibrated soot parameters provide a reasonable baseline from which to test design variations to see whether performance improves or degrades with design parameter changes, such as burner position, size, or injection angle.

When the soot kinetics calibration procedure is used, the derived soot kinetic parameter also implicitly accounts for some other unknowns or uncertainties in the models, such as air infiltration rates, variations in batch and other material properties, etc.

The soot calibration can also be done for oxy-fuel furnaces, however, soot kinetics are not nearly as significant in oxy-fuel furnaces because a large fraction of the radiation heat flux comes from the dominant combustion products, carbon dioxide and water vapor. More detailed information on the soot calibration procedure can be found in Appendix 1.

3.6.3 Other Enhancements in the Combustion Space Model

Many other enhancements to the combustion space model were implemented in GFM 4.0 to improve accuracy, numerical stability, and convergence of the simulations. The most significant of these enhancements are described in the following list.

- Special attention was paid to obtaining good energy equation convergence each time the energy equation is solved in the global iteration scheme. This improvement appears to have helped in achieving more rapid convergence and greatly improved final results for all of the governing equations in the simulation.
- The high level combustion space algorithm was revamped to speed up the computation. Major inefficiencies in the global combustion space solver organization were identified and the algorithm was redesigned, achieving a speed up by a factor between 2 and 5. This speed up makes automatic cycling convergence within a target of 24 to 48 hours much more feasible. While this efficiency gain may lead to shorter run times, it may also allow running with more refined grids to better resolve flow features to obtain acceptable accuracy.
- The convergence of the solution of transport equations for minor species and soot, which determines the volume radiation source distribution, was optimized by adjusting relaxation factors and the number of solver sweeps per global iteration.

- A relaxation algorithm for the temperature distribution passed as the surface boundary condition from the melt space computation to the combustion space computation in automated coupled cycling was implemented. This change was needed to damp wild temperature oscillations when cycling toward coupled melt and combustion space convergence. A similar relaxation algorithm was implemented for the melt surface heat flux distribution passed from the combustion space to the melt space computations.
- The restart algorithm was fixed so that solution precision is retained during restart.
- An energy equation wall function was added to the turbulence models to obtain a value for wall heat flux in regions of high turbulence. Convective wall heat flux is now computed using the turbulence model wall function in combination with the previous user specified heat transfer coefficient, depending on turbulence intensity in the vicinity of the wall. This wall function is used with the energy equation to enhance the model accounting for the convective contribution of heat transfer to walls and the melt surface.
- New routines to compute gas mixture enthalpy and to compute gas temperature from enthalpy were written using National Institute of Standards and Technology (NIST) rational functions for the enthalpy of a mixture species and a Newton solver to obtain temperature from enthalpy with an accuracy near machine precision. The new algorithm to compute mixture temperature from enthalpy replaced previous table based gas mixture enthalpy-temperature routines, which were accurate only to a few percent.
- The use of separate emissivities for walls, crown, and melt surface was implemented.
- The status output to the command prompt window was redesigned to make it more meaningful.

3.7 Melt Model and CFD Code Enhancements

The original melt model in the version 2.0 CFD code simply did not converge well and did not yield reasonable results unless the initial guess was close to a reasonable result and specific constraints were hard coded. Many problems had to be fixed to substantially improve this situation.

Major improvements were made to the batch heat transfer and melting model. These improvements were necessary to achieve a good accounting of energy transferred directly to the batch from the combustion space and indirectly from molten glass back to the batch. The algorithm for calculating the distribution of surface radiation to batch, cullet, and molten glass was corrected and improved. An improved model for handling the tip or end of the batch was added for numerical stability.

3.7.1 Melt Surface Heat Flux from Combustion Space Computation

The heat flux at the melt surface is computed in the combustion space computation. It determines the total energy entering the melt and its distribution over the surface. This heat flux distribution must be interpolated from the combustion space grid points to the melt space grid points at their shared interface. New routines were written to interpolate temperature and heat flux between the melt and combustion space grids at the interface between spaces. Testing of the old routines revealed significant errors primarily in the corners. Figure 8 and Figure 9 show results of interpolation using the new interpolation algorithm. The example results in Figure 9 clearly reveal another source of error in coupled solutions of the melt and combustion space that users should be aware of. Batch chargers are well resolved in the melt grid but not in the combustion grid in Figure 9. When cell sizes vary significantly at the melt surface when comparing the melt grid to the combustion grid, temperature and heat flux distributions may not be well resolved when transferring melt surface energy boundary conditions between the melt and combustion spaces. The heat flux interpolation does preserve the total energy transfer from combustion space to melt in doing the interpolation, and the temperature interpolation does preserve the area mean temperature over the melt surface.

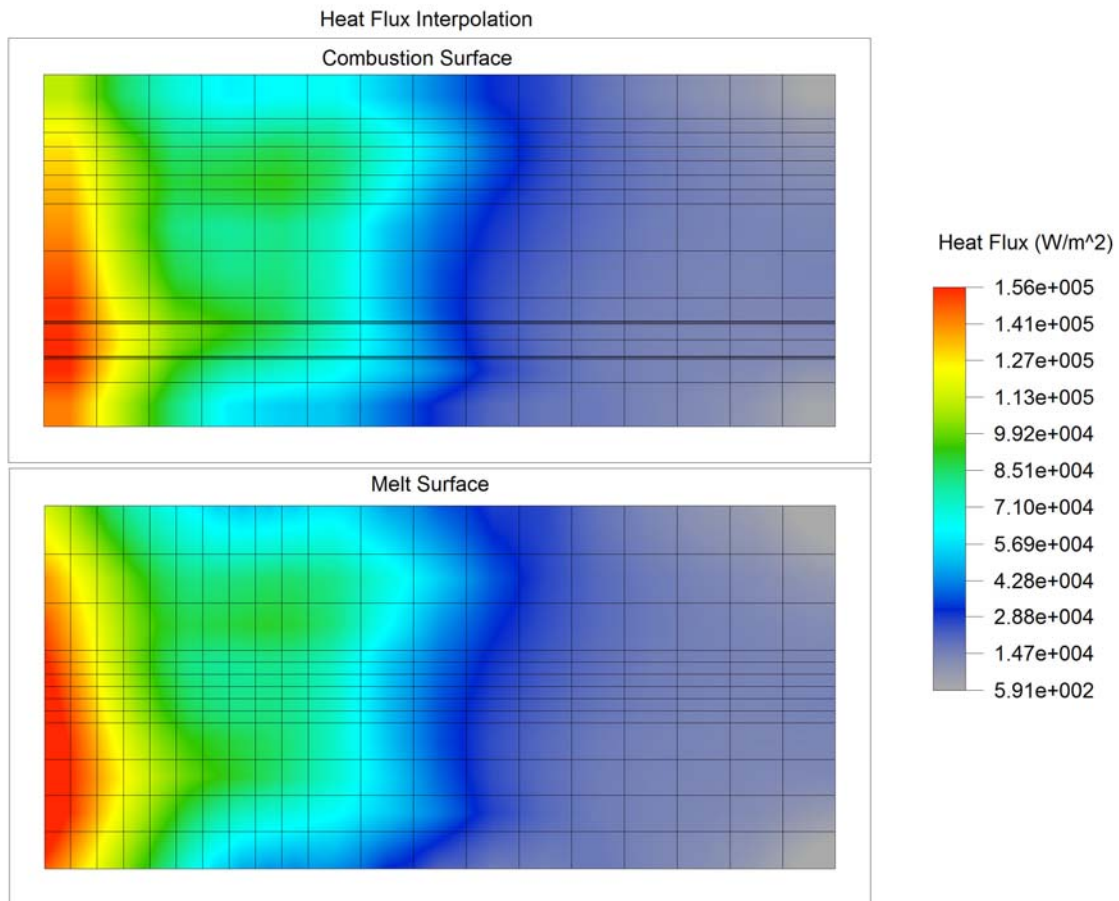

Figure 8. Reasonably well resolved heat flux interpolation between coarse grids

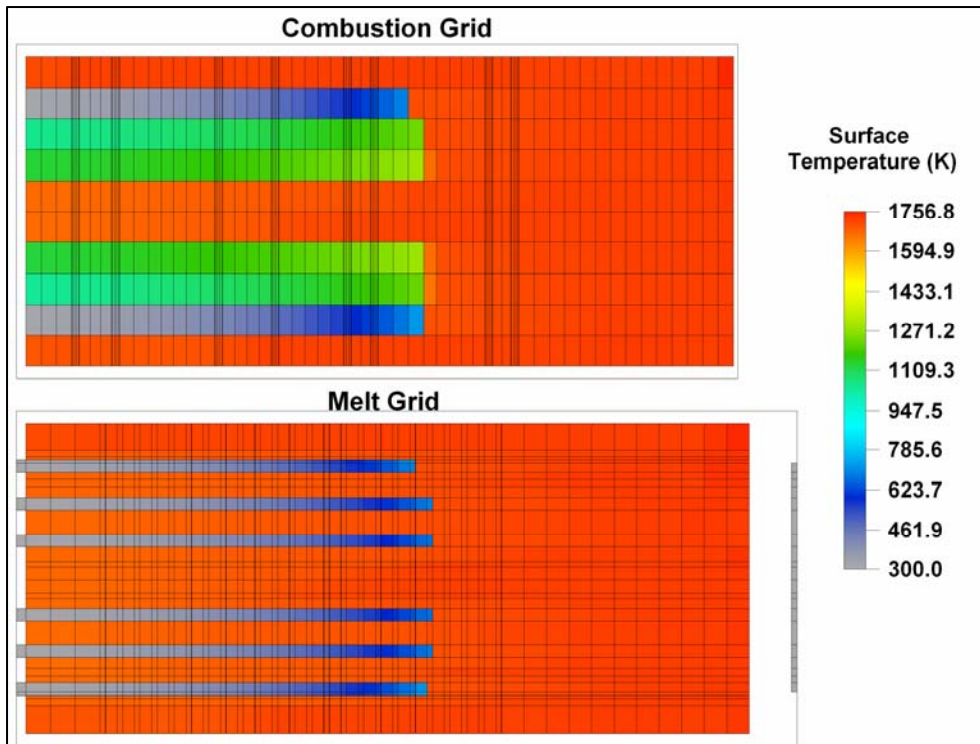

Figure 9. Loss of resolution in temperature distribution due to coarse combustion space grid

A scheme for handling melt surface dimensions that do not match exactly between the two domains, combustion and melt, was implemented. This situation might arise if furnace schematics show slightly different dimensions for melt and combustion spaces. The existence of small shelves or overhangs is not accounted for in the current model. The model assumes that the melt surface is a rectangle with the primary dimensions of the melt or combustion spaces. If these are slightly different, the interpolation of temperature or heat flux between combustion and melt grids assumes that the grids match at the center. The interpolation then scales the heat flux to preserve the total heat transfer from combustion space to melt and scales the temperature to preserve the area mean temperature.

Refiners and dog houses (sidewells) are handled by excluding them from the surface coupling condition computations. The model assumes that the melt surface in a refiner is adiabatic (heat lost from the surface is negligible). The effects of dog houses in the combustion space on the flow pattern are accounted for in computing the hydrodynamics, but the net effect of radiation heat transfer from dog houses is assumed to be negligible. Surfaces in dog houses are included in the wall radiation exchange computation, but shading of walls by intervening surfaces is not accounted for.

A constraint requiring a positive heat flux into the melt at every point over the entire melt surface was removed. This change yielded a pattern of oscillatory instability in cycling boundary conditions between melt and combustion space computations. The instability

problem was resolved by relaxing the coupling conditions between the melt and combustion space.

An option to scale surface heat flux into the melt was implemented. This option allows the user to specify an outlet boundary melt temperature and scale a uniform or calculated surface heat flux to meet energy needs for the outlet boundary temperature. This feature is needed to provide stability during the early cycles of a fully coupled melt and combustion space simulation. Normally the first eight to sixteen cycles of a coupled simulation should be run with scaling on to bring the combustion space crown and wall temperature and the melt temperature and velocity fields close enough to the solution for the simulation to reach stable convergence over the next 30 to 50 un-scaled cycles.

The melt surface heat flux scaling may also be useful for users on a standalone basis. Based on the batch inlet flow rates and material properties, the energy needed to heat the batch up to the melting point, to melt the batch, to heat the melted batch up to the outlet temperature, and to account for losses through walls is computed. The surface heat flux distribution is then scaled in this mode to provide the needed amount of energy. This scaling is repeated through the solution process to account for changing energy losses through the walls as the flow pattern in the melt develops. Scaling can be used to produce a reasonable melt solution for a particular charging rate when the energy entering the melt from the combustion space is either too high or too low. Results output from the scaled melt solution indicate how much adjustment is required in operating conditions, such as burner firing rates, in the combustion space to yield the desired charging rates and melt outlet temperatures.

3.7.2 Flow Boundary Conditions in the Melt

Free surface boundary conditions at the melt surface were improved. Pressure at the surface is taken to be the reference pressure which should be set to the pressure in the combustion space. This can be any reasonable mean pressure, often atmospheric pressure. In the momentum equations, free slip boundary conditions are applied to areas of the surface not covered by batch. Recognize that batch is often pushed into the furnace and that melting at the interface between batch and melt can cause the batch to form a shelf at the melt surface. When the batch layer is thick, it is treated as a moving wall to obtain momentum boundary conditions in the melt at the melt-batch interface. As the batch layer thins out it will break up and no longer exert a shear generated force on the melt. The batch model does not have sufficient detail to resolve batch layer breakup, however, a transition function is applied to the surface shear calculation between melt and batch to change smoothly from a moving wall condition to a zero shear condition as the batch layer thins out and melts completely.

Outflow boundary conditions were changed to a known velocity condition based on the user specified pull rate split between multiple exits when multiple exits exist. The outlet boundary conditions were previously free flow conditions, which in many cases caused over prediction of the outflow mass flow rate by a factor of two or more. The new outflow boundary conditions in combination with the automatically generated extended

exit tunnels in the grid yield solutions in test cases that balance mass entering and leaving the melter to nearly four significant figures. The addition of exit tunnels in the grid eliminated the numerical difficulties caused when a recirculation zone in the bulk flow occurs near an exit. Figure 10 shows an example of a melt space grid with an exit tunnel of sufficient length for outflow boundary conditions to be valid.

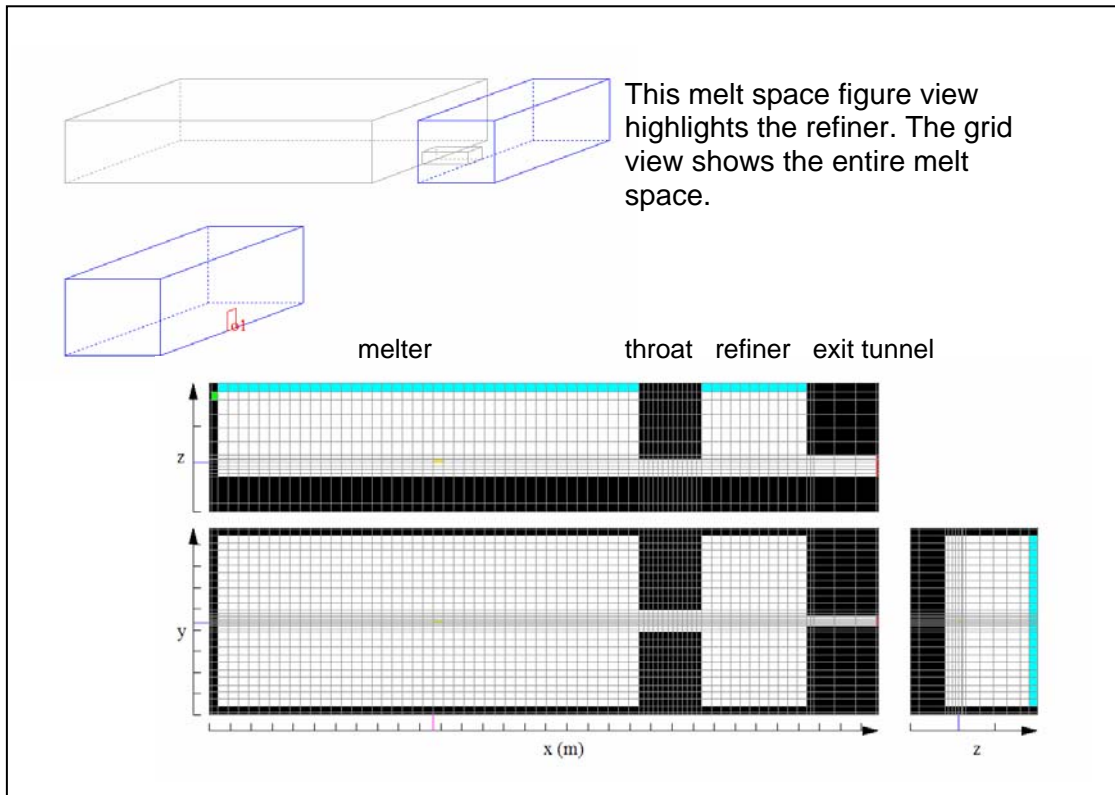

Figure 10. Melt space figure and grid view with exit tunnel

3.7.3 Other Enhancements in the Melt Model

The melt code was converted from a non-dimensional to a dimensional code internally to allow for relatively easy checking of dimensional consistency. A dimensional consistency check was performed and some minor problems were corrected.

Calculation and output of the mean residuals of the governing partial differential equation (PDE) for the melt was implemented. These residuals can be plotted versus the iteration number using the RunPlot utility program to observe progress toward a converged solution for the various equations that are solved (mass, momentum, and energy

transport). The residuals are normalized so that the log of the residual indicates the approximate number of significant digits in the solution.

The PDE solver relaxation factors were adjusted to improve convergence (lower residuals) while maintaining computational efficiency. These relaxation factors were also made available for user adjustment for cases in which good convergence is difficult to obtain. Appendix 1 contains a discussion of which of these parameters to adjust and how to adjust them in difficult cases based on trends in equation residuals that can be plotted via the RunPlot utility provided with GFM.

Temperature dependent cullet and batch specific heats were implemented using a table of user defined values passed in a file from the user interface and control program.

3.8 RunPlot Simulation Progress Plotting Program

To facilitate rapid isolation of problems, a substantial amount of data collection on the state of the computation was implemented in both the melt and combustion space CFD codes. To quickly view and analyze this data, a new tool, RunPlot, was written. This status monitoring program provides for on screen plotting of status and progress variables during the course of a simulation. RunPlot makes it easy to see how a simulation is progressing and when temperatures and heat transfer rates have stabilized indicating that the simulation is done. RunPlot also makes it easy to spot problems in a simulation and take steps to correct them. Refer to Appendix 6.

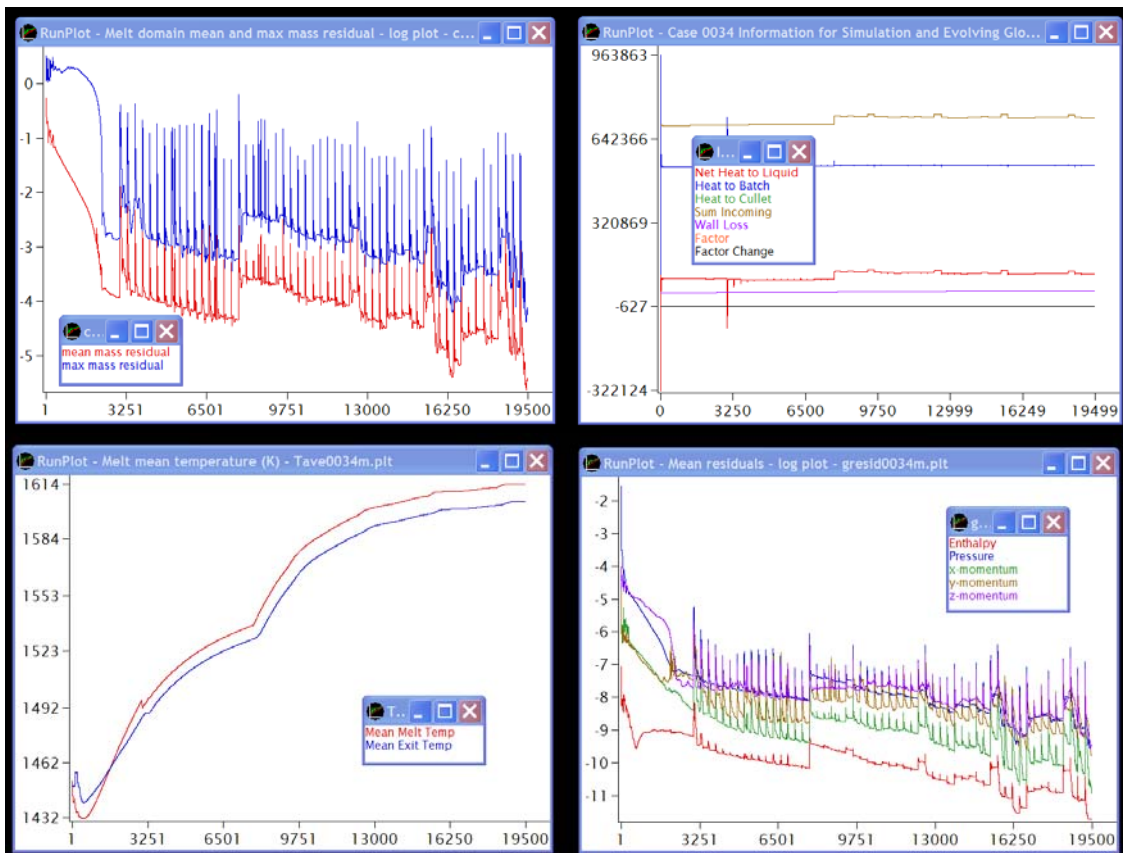

Figure 11. Melt domain sample RunPlots

Examples of status monitoring variables are residuals from the governing mass, momentum, and energy conservation equations, average temperatures, combustion space energy release and distribution (to melt, to exhausts, loss through walls, etc.), energy distribution and balance within the melt (energy transfer to solids, liquid, walls, etc.). Examples of several of these plots are shown in Figure 11 and Figure 12.

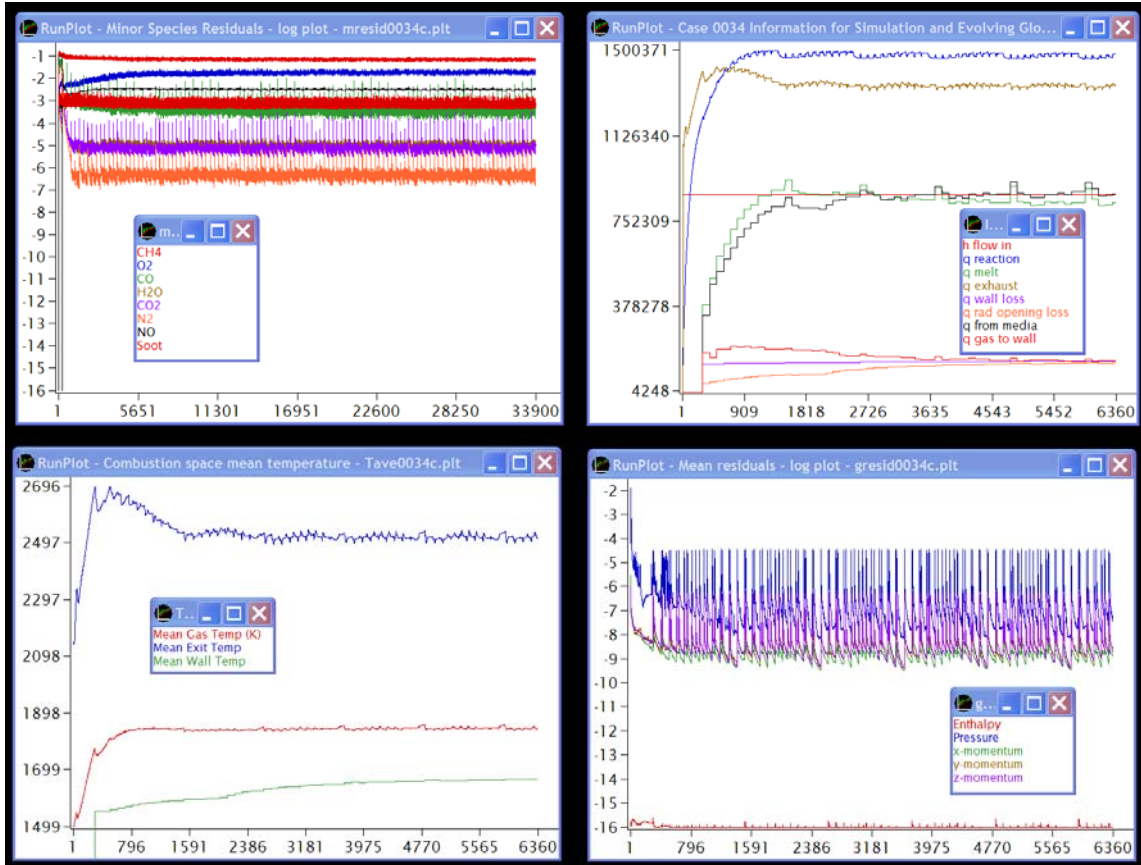

Figure 12. Combustion domain sample RunPlots

In addition to being a powerful tool for GFM developers to trouble shoot problems, RunPlot is also a very useful tool for GFM users. Using the RunPlot program to monitor simulation status provides a visualization of simulation progress and current state of the solution that is much easier to assess than trying to determine from numeric summary data displayed in user interface windows if the solution state is physically realistic and progress toward a solution is reasonable. Features included in the RunPlot program to increase its utility for GFM users include the following:

- Display options allow font size to be changed, the number of ordinate axis labels to be increased or decreased, the background color to be toggled for screen prints, and a new file to be opened. These options are available through the keyboard shortcuts and a right click mouse button menu.
- A color coded legend in a separate window was included to identify the colored plot lines. The legend can be closed and toggled back on.

- RunPlot can be used to display the history of progress and state of a simulation after the CFD computation has terminated. This capability provides a quick way to visually review trends in the status and state data without the work of importing the data files into a spreadsheet program that has plotting capabilities.

3.9 Documentation

New GFM documentation is available from the Help item on the GFM menu bar. This documentation is provided in PDF format. The user must, independently of GFM, have a viewer (such as Adobe's Acrobat Reader) installed to display the documentation files. These files are also installed in a document folder in the GFM directory tree. They can be opened and read on the computer or printed and read at the user's convenience.

The document folder installed with GFM contains the following documents:

- *GFM 4.0 Tips and Special Procedures*
The *GFM 4.0 Tips and Special Procedures* document provides a variety of useful information for using GFM. It also contains a discussion of the soot model calibration procedure and instructions for carrying it out. For cases that fail to converge to a stable steady state solution, a procedure for identifying solver parameters to adjust and how to adjust them is explained.
- *GFM 4.0 Graphical User Interface Menus*
The *GFM 4.0 Graphical User Interface Menus* document contains tables with brief notes that map out the menu system in the GFM user interface in one place.
- *Using the GFM 4.0 Graphical User Interface to Build, Run, and Review Models: Two Examples*
An example of how to build a furnace model with step by step instructions for navigating the menu system to accomplish the data entry tasks is contained in the document *Using the GFM 4.0 Graphical User Interface to Build, Run, and Review Models: Two Examples*. This document also contains instructions for creating a new simulation case from an existing case with different run parameters. The procedure allows users to easily build and run a parametric series of simulations over an operating parameter of interest, such as burner firing rates.
- *GFM 4.0 Files*
GFM 4.0 Files contains a discussion of the different file types that are generated during the construction and simulation of a furnace model and a set of tables listing the files by category with a note indicating file contents. Because file handling is automated in GFM 4.0 and the user works with cases, very little information on the files generated by GFM is needed by users. However, Tables 2 and 5 are useful. They list the files in the combustion space and melt space respectively that contain simulation monitoring data that can be plotted with the RunPlot program.

- *GFM 4.0 Automated Cycling Guide*
A detailed discussion of the simulation cycling capability and procedures for setting up and starting cycling runs is found in *GFM 4.0 Automated Cycling Guide*.
- *GFM 4.0 RunPlot User's Guide*
The *GFM 4.0 RunPlot User's Guide* provides an overview of the status monitoring program provided with GFM.
- *GFM Copyright Notification*
- *Glass Furnace Model (GFM) Software License Agreement*
- *Glass Furnace Model (GFM) Development and Technology Transfer Program Final Report* (this document)
The *Glass Furnace Model (GFM) Development and Technology Transfer Program Final Report* document provides GFM project background information and detailed lists of the enhancements in GFM 4.0 with discussion of the major new features.

4 International Commission on Glass Technical Committee 21 Test Case

4.1 Test Case Included in GFM 4.0 Software Package

A solved sample test problem is included in the GFM 4.0 release. This test problem simulates hypothetical 20 ton/day and 40 ton/day regenerative glass melting furnaces coupled to the glass melt. The sample problem definition is taken from the round robin test conditions specified by Technical Committee 21 (TC21) of the International Commission on Glass (IGC). The purpose of the TC21 committee is to share and exchange current information on efforts to model the processes in glass furnaces and to promote the development of the theory and application of mathematical modeling of glass furnaces. The GFM 4.0 sample problem is based on round robin tests 4 and 4a of the TC21 committee. The specifications for these tests are in Appendix 7. These test cases were chosen as the base cases for testing upgrades in GFM 4.0 because the geometry is simple, allowing tests to be run in a little more than a day, and because results can be compared with those of other glass modelers from around the world who are members of the TC21 committee of the IGC. Funding was not available for more extensive testing.

4.2 Test Case Results and Discussion

The convergence monitoring plots for the 40 ton/day case are shown in Figure 11 and Figure 12 of Section 3.8. The spikes in these plots generally occur when the melt surface boundary conditions are perturbed in cycling between the combustion space and melt space computations. While many of the plotted values settle down to their final range of values fairly quickly, the cycling is continued until the heat flux and temperature distribution boundary conditions exchanged between melt and combustion space computations are stable to about three significant figures. The simulation is also continued until the volume mean melt temperature and area mean melt exit temperatures have reached stable asymptotic values. They are just reaching asymptotic values in the plot in the lower left corner of Figure 11. These conditions were reached after about 60 cycles between the melt and combustion spaces.

4.2.1 Visualization of Test Results

Examples of visualization of results that can be obtained with the post processor provided in GFM 4 are shown in this section. Color density plots of the combustion space temperature with velocity vectors are shown in Figure 13. The z-x plane is cut vertically through the burner at one of the fuel ports. It shows the penetration of the jet flame into the furnace and the recirculation zone that forms above the flame. The y-x plane is a horizontal slice through the fuel inlet ports of the burner. It shows penetration of the jet

flame into the furnace at the height of the slice. The fuel jet is directed eight degrees upward, and consequently the maximum penetration of the flame is in a plane above the fuel inlet ports. Color density plots of the melt space batch coverage are shown in Figure 14. The batch coverage is about 1/3 of the furnace surface. This batch coverage was computed from a mean heat flux obtained from averaging the left and right side burner firing conditions. This approach assumes that the melt responds slowly to changes in conditions in the combustion space above. In reality, batch length on the surface will be less on the side with the active burner near the end of that burner's firing period.

TC-21 40TPD Combustion Space Gas Temps & Velocities

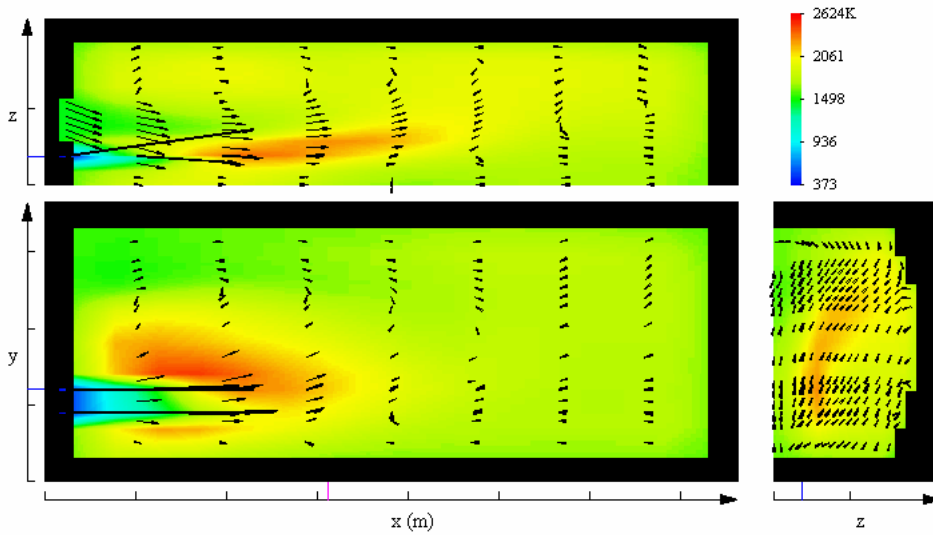

Figure 13. Temperature distribution and flow pattern in the fuel injector planes

TC-21 RRT4a 40 TDP batch cover mass fraction.

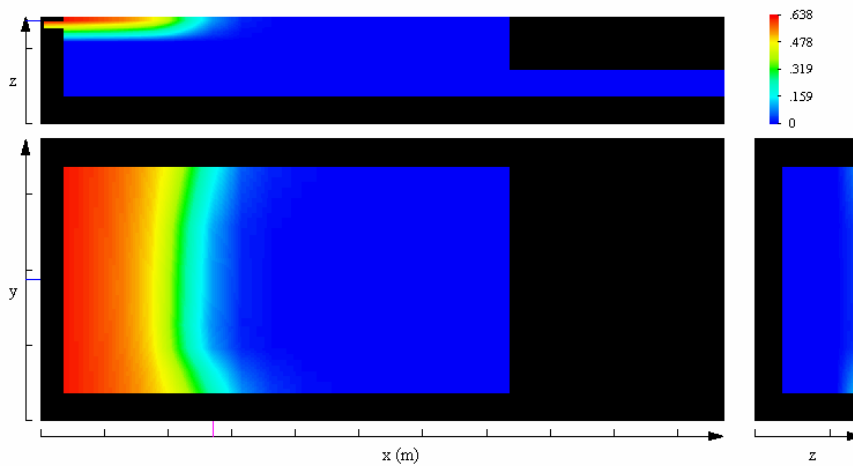

Figure 14. Batch coverage computed from the mean of left and right side firing modes

Plots of the temperature distribution and flow pattern in the melt in selected planes near the surface and through the center of the exit throat are shown in Figure 15. The average heat flux from the two burner firing configurations was also used in the melt simulation to obtain this result. As a consequence, the pattern is nearly symmetric across the centerline.

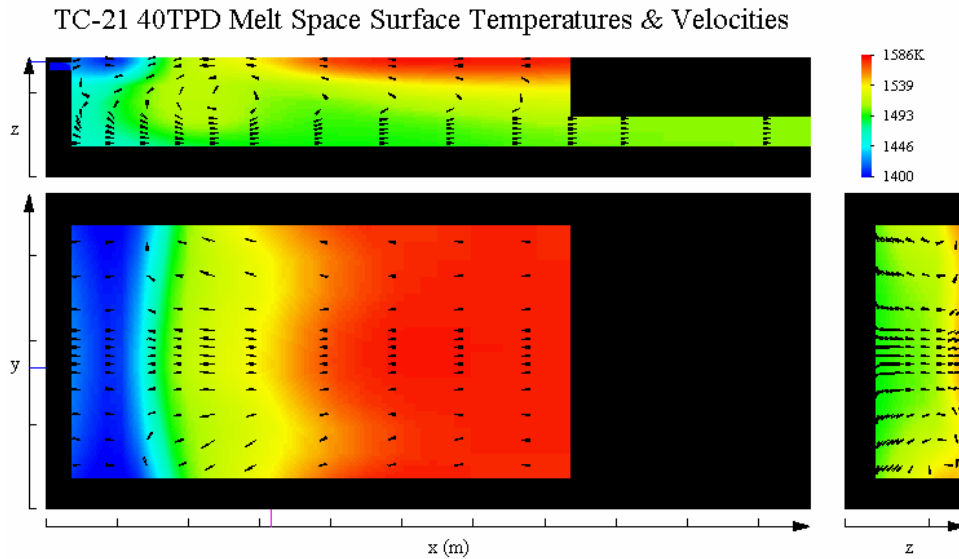

Figure 15. Melt temperature distribution with flow pattern near the surface and through the exit throat

4.2.2 Test Result Summary Data

Summary data files are produced for both the combustion and melt spaces. The data in these files include a variety of values obtained by integrating over boundaries or the volume of the domain. Examples are inlet flow conditions (how much mass and energy is coming in with the flow), energy requirements for the melt based on the solids inflow rate, material properties, and a user specified outlet mean glass temperature, and where the energy ends up, such as how much goes out the exhausts, goes into the melt, is lost through walls, etc..

Figure 16 contains the summary data for the combustion space for right side firing of the burners. The top section gives the mass flow rates through the burners along with the heating value of the incoming fuel. These numbers are followed by two ways of doing an energy balance: one on the gas in the combustion space and one on the combustion space including the walls. The energy balance on the gas is accurate to about 3 significant figures and on the furnace including the walls and others surfaces to about 3 percent. The details of the energy balances provide useful information on where the energy coming in with the flow and released in the combustion ends up. For example, in this test problem about 60% of the energy coming in goes out through the exhaust with the combustion product gas, about 3.6% is lost through the walls and crown and approximately another

3% is lost via net radiation heat transfer through exhaust and burner openings. About 33% of the energy is transferred to the melt. Nearly all of the energy transferred to the melt is radiation heat transfer from interior surfaces; only about 6% is direct radiation from the flame and less than 1% is due to convection from the hot gas above the melt surface. About 3% of the incoming energy is transferred to walls via convection, which raises the wall temperature and contributes indirectly to the radiation heat transfer from surfaces to the melt. This type of order of magnitude information can be used to identify the parts of the process where investment in analysis and consequent changes in furnace design or operating conditions have the greatest potential of achieving significant gains in energy efficiency.

An example of summary data for the melt space simulation is shown in Figure 17. The top section gives the boundary data for the melt surface and inlets (chargers). Based on the batch and cullet solids in flow rate, the material properties, and a user specified mean glass exit temperature, the energy required to heat up, melt the solids, and then heat up the molten glass to the mean outlet temperature is listed. The sum of these values is an estimated adiabatic energy requirement for the melt (the energy rate required not considering wall losses that are computed in the simulation). In the example shown in Figure 17 this value is about 1.03 MW.

In the full summary file, data on the various energy transfer rates for the melt space and mass balances are given at the end of each cycle. The last set of such data at the end of a set of cycles is shown in Figure 17 under the header “Run End.”

In the section of the run summary data under “Run End” the following information is provided. The net energy coming in to the melt through the melt surface via radiation and convection and electric boost is listed. The next block in this section lists the energy requirements for the incoming solids to heat them to the melting point and then to melt them. Energy transferred to the solids is listed. This energy comes from two sources, direct heat transfer from the combustion space via radiation and convection and energy transferred by conduction from the molten glass below the solids on the surface, in the case shown this value is about 0.86 MW. Energy transferred from the molten glass to the solids to heat and melt them from below must enter the system through areas of the melt surface not covered by batch or from electric boosters (not present in this case). The summary data lists both the total energy needed to heat and melt the batch and the net energy transferred to the batch from the combustion space above and the molten glass below.

```

# Case 0040 Summary Data for Simulation and Evolving Global Energy
Distribution

#   Number of cells in combustion grid:    4377
#   Melt surface area:                    0.21000000000000E+02 m^2

#   Fuel in flow rate:                    0.39762878083587E-01 kg/s
#   Oxygen in flow rate:                  0.17547777964822E+00 kg/s
#   Nitrogen in flow rate:                0.57791249651488E+00 kg/s
#   Total in flow rate:                   0.79315315424668E+00 kg/s

#   Heat value in with fuel:              0.19881439041793E+07 W

# ##### Run End #####

# Energy Balance on Exterior Walls
# -----

#   Total energy in:                      0.31194147751189E+07 W
#     Energy in with flow:                 0.12138062448321E+07 W
#     Energy in via combustion:            0.19056085302868E+07 W

#   Total energy leaving furnace:         0.32324909367981E+07 W
#     Energy out with flow:                0.19415082875191E+07 W
#     Energy out through walls:            0.11512325088072E+06 W
#     Net radiation out inlets:            0.53023501285162E+05 W
#     Net radiation out outlets:           0.43845615784386E+05 W
#     Energy out to melt:                  0.10789902813288E+07 W
#       from flame:                        0.69858445806380E+05 W
#       from surfaces:                      0.10073147307997E+07 W
#       from convection:                    0.18171047226586E+04 W

# Gas Energy Balance
# -----

#   Total energy in:                      0.31194147751189E+07 W
#     Energy in with flow:                 0.12138062448321E+07 W
#     Energy in via combustion:            0.19056085302868E+07 W

#   Energy out with or from the gas       0.31410604666860E+07 W
#     Energy out with flow                 0.19415082875191E+07 W
#     Convection to walls                  0.98690935007754E+05 W
#     Convection to melt surface           0.18171047226586E+04 W
#     Radiation from flame to melt:        0.38234011234061E+06 W
#     Radiation from flame to walls:        0.69503424954264E+06 W
#     Radiation from flame to inlets:       0.98159536449222E+04 W
#     Radiation from flame to exits:       0.11853823908353E+05 W

# -----

#   Mass in:                              0.79273500724714E+00 kg/s
#   Mass out:                              0.79273067980525E+00 kg/s

#   Fuel mass out:                        0.19549812479519E-02 kg/s
#   Fuel energy out:                       0.97749062397594E+05 W

#   Mean temperature:                     0.17651095783624E+04 K
#   Mean exit temperature:                 0.18208686791114E+04 K
#   Mean wall temperature:                 0.16301531064894E+04 K

```

Figure 16. Summary data from last cycle of 40 TPD RRT4 combustion space simulation

```

# Case 0040 Summary Data for Simulation and Evolving Global Energy
Distribution

#   Number of cells in melt grid:           2780
#   Melt surface area:                     0.21000000000000E+02 m^2

#   Specified exit temperature T_ex        0.15500000000000E+04 W
#   Estimated wall loss at T_exit:         0.56094396111112E+05 W
#   Mean Surface Heat Flux:                0.47619047619048E+05 W/m^2

#   In-Flows:

#   Batch:                                 0.46296290446212E+00 kg/s

#   Heat Inputs and Requirements:

#   Radiation + Convection:                0.10000000000000E+07 W
#   Alternate Burners Rad + Conv:          0.10000000000000E+07 W
#   Electric Boost:                        0.00000000000000E+00 W
#   Total Energy In:                      0.10000000000000E+07 W

#   Batch heatup:                          0.50483368635668E+06 W
#   Batch melt:                            0.34722217834659E+06 W
#   Batch q needed:                        0.85205586470327E+06 W

#   Liquid heatup need:                    0.16433877315598E+06 W
#   Adiabatic energy need:                 0.10163946378592E+07 W

# ##### Run End #####

#   Heat Values at Run End:

#   Radiation + Convection:                0.10763815173279E+07 W
#   Electric Boost:                        0.00000000000000E+00 W
#   Total Energy In:                      0.10763815173279E+07 W

#   Batch heatup need:                     0.50483368635668E+06 W
#   Batch melt need:                       0.34722217834659E+06 W
#   Radiation to Batch:                    0.67810159011925E+06 W
#   Conduction to Batch:                   0.18302800210705E+06 W
#   Batch q needed:                        0.85205586470327E+06 W
#   Batch q net:                           0.86112959222631E+06 W

#   Liquid heatup need:                    0.16433877315598E+06 W
#   Liquid q net:                          0.15970375204391E+06 W
#   Adiabatic energy need:                 0.10163946378592E+07 W
#   Wall heat loss:                        0.55548173057651E+05 W
#   Net melt input energy need:            0.10719428109169E+07 W
#   Actual melt input energy:              0.10763815173279E+07 W

#   Energy need divided by input:          0.99587627031910E+00

#   Mean glass exit temperature:           0.15423242163494E+04 K
#   Batch rate in:                         0.46296290446212E+00 kg/s
#   Melt rate:                             0.46296290446357E+00 kg/s
#   Glass rate out:                        0.46296311924483E+00 kg/s

```

Figure 17. Summary data from last cycle of 40 TPD RRT4 melt space simulation

The third block of melt summary data at run end lists energy needed to heat the molten glass from the melting point temperature to a user specified mean molten glass outlet temperature, computed wall heat loss, and total energy needed by the melt compared to actual energy entering the melt through the surface from the combustion space and electric boosters if present. The ratio of the energy needed by the melt, including wall losses, to incoming energy is listed. Changes in the combustion space geometry or operating parameters that improve furnace efficiency will increase the melt outlet temperature because more of the combustion energy is transferred to the melt. The firing rate of burners in the combustion space will need to be decreased to bring the melt energy need versus energy input back into balance, which provides an estimate of fuel savings that could be obtained from an improvement in the design or operating conditions.

The last block of data in the melt summary data at run end lists the computed mean glass exit temperature and the total mass rates, which can be compared for balance. These include the total rate of solids coming in, the melting rate, and mass rate of molten glass leaving the system. In Figure 17 these values are about 0.46 kg/s and they match to about five significant figures.

To conclude, the summary data can be used both to check the simulation to verify that the various energy and mass transfers in the system all balance and to understand how the melt is operating in terms of the relative size of the various energy transfers.

4.2.3 Reporting of Test Results to the IGC TC21 Committee

The TC21 committee specifications for RRT4 and RRT4a tests have been evolving over time as models improve and fewer simplifying assumptions are needed to bring the hypothetical furnaces of the specification closer to a real furnace. Results of the current TC21 problem computations were reported and discussed at the TC21 committee meeting at the ICG International Congress on Glass in Strasbourg, France, 2007. Flow patterns, temperature distributions, batch coverage, and other results from the test problem are within the range of those obtained by other modelers running the test problem. A few final changes to the RRT4 and RRT4a specifications have been made by the committee. A member of the committee, who has been beta testing GFM Version 4.0, is planning to obtain a final set of results for the RRT4 and RRT4a tests with the latest parameter changes and submit them to the committee for comparison with other models. A report from the TC21 committee giving results of this comparison is expected in the future.

5 Availability of the Glass Furnace Model Version 4.0 at Project Completion

Version 4.0 of the Glass Furnace Model with the extensive enhancements and model upgrades described in Section 3 and the Appendices has been released. GFM Version 4.0 can be ordered via Argonne's Office of Technology Transfer Software Shop web site. It is currently offered for license on the commercial side of the Software Shop. A description and license information can be viewed at:

http://www.anl.gov/techtransfer/Software_Shop/GFMSoftware/GFM_Software.html

GFM is currently offered with an initial free six month trial license. License fees for the commercial license after the trial period have been reduced to \$3,000 for a U.S. company and \$6,000 for a foreign company, respectively, for a single copy of the software package. A university/non-profit license is also offered at \$500 for a U.S. university and \$700 for a foreign university.

The Glass Furnace Model software version 4.0 is copyrighted, ANL-SF-01-030c.

An Argonne technical contact is available for limited questions regarding use and installation of the GFM software. However, because funding for continuing development and support of the software is no longer available, extensive technical support or changes to the software must be arranged for on a cost recovery basis. The technical contact for GFM is:

Steven A. Lottes, Ph.D.
Energy Systems Division
Argonne National Laboratory
9700 South Cass Ave.
Argonne, IL 60439-4815

Phone: (630) 252-7014

Fax: (630) 252-1342

SLottes@ANL.gov

The contact in Argonne's Office of Technology Transfer for licensing information is:

Paul Betten

Software Licensing Coordinator
Office of Technology Transfer-201
Argonne National Laboratory
9700 S. Cass Ave.
Argonne, IL 60439
Phone: (630) 252-4962
betten@anl.gov

Appendix 1

GFM 4.0 Tips and Special Procedures

The information in this document is provided on diverse topics to help users effectively apply the Glass Furnace Model and resolve or avoid problems when using it. It includes procedures for calibrating the soot model and manually adjusting relaxation factors to improve simulation convergence or achieve convergence for numerically difficult problems.

1. Tips and Things to Know about GFM

Known Problems with Work-Arounds

- Case folders will not be automatically deleted. The *Delete Case* menu item will delete all the files in the case folder. However, an unresolved problem in Windows prevents the case folders from being deleted. GFM must be exited before a case folder can be manually deleted.
- The simulation run status displayed in the green boxes is now very limited. Some of the variables that were displayed before are no longer used or may have changed due to the major upgrades that have been done to the CFD code, especially for radiation. This interface with the GUI has not been reworked. The new RunPlot program is an excellent tool that can be used to monitor the simulation progress. The command prompt window also provides simulation progress information.

General Information

- Case folders and files must be in the proper directories.
- Case folders and files must be named properly. Renaming case folders using long file names with keywords can make saved cases easy to identify, however, to reprocess those cases in GFM, the case folders must be renamed with their original name.
- Files should not be modified manually. (An exception exists for the relaxfactor[m/c].txt files as explained below in the Adjust Relaxation Factors Procedure.)
- Some actions cause the furnace figure or grid plot to be moved or resized. Use the green box diagram handles to resize or reposition the diagram. The lower left corner handle is for moving the diagram. The upper right corner (where the 3 grid slices meet) handle is for resizing.

- Sometimes a new burner cannot be added to the furnace. Adding or deleting an object from a constructed furnace will cause the grid to be reconstructed and then previous enhanced grid edits would be lost. Therefore, when an enhanced grid edit is made, the *Protect Grid Edits* option is automatically checked and objects will not be allowed to be changed. The *Protect Grid Edits* option can be turned off when the user really wants to modify the grid.
- The open file dialog box in RunPlot usually comes up in the directory of last use (as opposed to the one of the current case). The user may navigate to the directory of the file to open.
- Multiple instances of RunPlot may be run, and the RunPlot windows can be moved and resized to easily monitor the status of variables from different data files simultaneously.

Combustion Domain

- Air is assumed to be composed of nitrogen and oxygen only.
- Radiation must be turned on in the combustion space for cycling runs. In general, heat transfer under furnace operating conditions is dominated by radiation heat transfer. Therefore, although combustion simulations can be run without the radiation heat transfer computation included, the gas temperatures will likely be unrealistically high because heat loss from radiation has not been accounted for.
- The number of iterations in a combustion run may exceed the user specified value. Ten extra gas phase iterations will be added after a full radiation calculation has been done, even if the user set iteration count has been exceeded, so that the radiation information gets propagated into the gas flow field.

Melt Domain

- In order to resolve the flow field at melter outlets, the grid will show a thick wall and exit tunnels. For the purposes of estimating heat losses through walls, the wall thickness specified by the user is used for all walls regardless of how they have been modified in the grid generation process.
- Melter outlet tunnel information (in the green boxes) applies to all the melter outlets. This information cannot be changed for individual outlets.
- Melter outlet pull rate fractions are automatically changed when an outlet is added or deleted. The user can change the pull rate fraction values individually.

Simulation

- Convergence is determined by looking at the convgnnnn[m/c].plt file via the RunPlot program. The graph will show the normalized mean and maximum mass residual as a logarithmic plot in either the melt [m] or combustion [c] domains. Considering a computational cell as a control volume, the absolute value of the log of the normalized mean mass residual indicates how many significant digits of mass balance have been achieved in the computational cells averaged over the entire grid. When the simulation has converged, the mean residual line should be at a level of -3 or less, although in difficult to converge cases, some useful information may be obtained when the mean mass residual is below -2. When the mass residual plot has gone asymptotic, further iteration is not likely to significantly improve convergence in terms of mass balance. However, other significant physical characteristics of the system, such as the mean temperature may still be evolving. Iteration should be continued until all major measures of system state have stabilized.
- Certain variables are extremely sensitive to various conditions that may cause the temperature to go way beyond a realistic value or prohibit the simulation from converging. When such a situation occurs, stop the run and do the following:
 - Look at the grid to be sure that it has been constructed properly. Make sure the inlets and exits are properly located and sized.
 - Carefully review all the properties, parameters, conditions, and options that can be set in the pre-processor to make sure that they are realistic and agree with the furnace design. Doing an approximate heat balance for the furnace operating conditions can be very useful in identifying unrealistic parameter values.
 - Examine the flow patterns within the furnace by entering the post processor and clicking on “vectors” in the grid control block. Change positions in the grid and relick “vectors” as needed to get a good idea of what the flow pattern is. Perhaps better resolution is needed near various objects to improve the flow. In that situation, create a new case with a refined grid that is denser near those objects.
 - Use the Soot Model Calibration Procedure given below.
 - Use the Adjust Relaxation Procedure given below.
- If the simulation display updates have been turned off during a run, then the old information that is not current will remain on the screen even after the run is done.
- There is more than one way to tell if a simulation is running.
 1. There may be a long delay between GUI display updates to the status boxes in the main GFM application window, especially when there are many cells in the grid and during initialization (at startup and when changing between calculation models). First make sure that the menu item *Options* → *Simulation Display Updates* → *Simulation Display Progress*

- On* is checked. This option defaults to being off because updating the colored plot display takes up extra CPU time.
2. The GFM menu bar will have an item ***Stop Run*** while a simulation is running. This menu item will change to ***Done*** after the simulation stops.
 3. Look at the Windows task bar for the CFD program's command window icon. Click it open to see the simulation status. If the window cannot be found, then the simulation is not running.
 4. The Windows task manager can also be checked to see if the melt or combustion programs (melt.exe or comb.exe) are running as tasks.
- Remember that every new cycle and change of domain represents a new CFD program run and the option settings for each run are taken from the case settings for both domains before cycling was started, except for those that must be modified for cycling (such as “restart” versus “new start”). Before starting a cycling run, set the options as generally desired. Options can still be modified during each of the individual runs.
 - Sometimes a simulation restart fails. There are several things that can cause a restart to fail:
 1. If a grid has been modified, then the simulation must be started as a “new run.”
 2. In a series of parametric runs generated using ***Save Case As (Full Case)*** to create a “good” starting point from a previous case when a parameter is changed, the parameter change may be too large. Try changing the parameter in smaller increments or using a new start.
 3. When restarting a cycle run, do not open the case; just use the ***Simulate*** menu to start another cycle. If the case has been reopened, then verify that the run parameters are correctly specified for restarting before saving the case.
 - There are a couple strategies that can be used to speed up a simulation:
 1. Make sure the menu item ***Options*** → ***Simulation Display Updates*** → ***Simulation Display Progress Off*** is checked because updating the display takes extra processing time. Monitor run status by watching the command window or using RunPlot.
 2. Simplify the grid if possible. Make the grid coarser.
 3. It may be possible to increase computational relaxation factors by using the Adjust Relaxation Factors Procedure below. However, this is a trial and error strategy which may not work. The best situation for its use is to begin with a case that has an established flow field and is somewhat converged, as example when doing parametric studies based from one converged case that is copied as a starting point for using a different value of the parameter being studied.
 4. Reduce the number of iterations for radiation and/or minor species in the green boxes displayed when the menu item ***Properties*** → ***Simulation Parameters*** is clicked. This is also a trial and error strategy.
 5. Reduce the radiosity solver loop limits via the menu item ***Properties*** → ***Radiation Controls***. This is also a trial and error strategy.

2. Soot Model Calibration Procedure

In air-fuel furnace simulations, the radiation heat flux solution is very sensitive to soot production, distribution, and oxidation. To accommodate simulation with the resources of a PC, a reduced two step soot production and oxidation model is used that has four kinetic parameters. In air-fuel furnaces, the magnitude of the total heat flux to the melt is very sensitive to the kinetic model soot parameters, and these parameters may need adjusting for different types of burners, fuel, and furnace geometries.

GFM soot transport is assumed to be governed by the general equation for subspecies transport. Transport of soot as a mass fraction of the gas mixture is then:

$$\frac{\partial}{\partial x_i} \left(\rho u_i Y_s - \Gamma_s \frac{\partial Y_s}{\partial x_i} \right) = R_{sf} - R_{so} \quad 2.1$$

Where

$$R_{sf} = A_{sf} Y_f \exp \left(\frac{-E_{sf}}{R_g T} \right) \quad 2.2$$

and

$$R_{so} = A_{so} Y_s Y_o T^{1/2} \exp \left(\frac{-E_{so}}{R_g T} \right) \quad 2.3$$

Einstein index notation is assumed in Equation 2.1, and Y_s is the mass fraction of soot, Γ_s is the turbulent diffusivity of soot, and R_{sf} and R_{so} are the formation and oxidation rates of soot in $\text{kg}/(\text{kg}_{\text{mixture}})$ per unit volume, respectively. In Equation 2.2, A_{sf} is the pre-exponential constant in the soot formation rate equation, E_{sf} is the activation energy for soot formation, and Y_f is the mixture mass fraction of fuel. Similarly, in Equation 2.3 A_{so} is the pre-exponential constant in the soot oxidation rate equation, E_{so} is the activation energy for soot oxidation, and Y_o is the mixture mass fraction of oxygen. The model parameters are the pre-exponential constants and activation energies, A_{sf} , A_{so} , E_{sf} , and E_{so} . Their default values are given in Table 2.1.

Table 2.1 Soot Formation and Oxidation Model Kinetic Parameters

Parameter	Value	Units
A_{sf}	0.00353	$\text{kg}_{\text{soot}}/(\text{kg}_{\text{fuel}} \cdot \text{s})$
A_{so}	30	$\text{kg}_{\text{mix}}/(\text{kg}_{\text{fuel}} \cdot \text{K}^{1/2} \cdot \text{s})$
E_{sf}	3325720	J/kmol
E_{so}	3325720	J/kmol

All of these model parameters can be changed by the user. The soot distribution and net radiation from soot appear to be most sensitive to the value of the pre-exponential constant for soot formation, A_{sf} . Therefore, the automated soot model calibration

procedure finds a value of the soot formation kinetic constant, A_{sf} , based on operating condition data from an existing furnace or design point conditions for a new design combined with an expected efficiency at the design point. In new designs, the calibrated soot parameter provides a reasonable baseline from which to test design variations to see whether performance improves or degrades.

The soot calibration can also be done for oxy-fuel furnaces, however, soot kinetics are not nearly as significant in oxy-fuel furnaces because a large fraction of the radiation heat flux comes from the dominant combustion products, carbon dioxide and water vapor.

Step 1. Open or create a new case in the melt domain just as would be done for a regular (non-calibration mode) simulation. When setting the values for items in the green boxes (displayed after clicking on the *Properties* → *Simulation Parameters* menu item), make sure the second line in the left-most green box shows “new start” and the next line has an iteration count set high enough to get an established flow field and stabilized bulk melt and surface temperature in the melt, possibly as many as 1000 to 3000 iterations. The **RunPlot** program can be used to monitor how many iterations it takes for the mean temperature in the melt to begin to go asymptotic. In the right-most green box set the heat flux to “scaled”, “uniform value”, and provide an estimated value required for the furnace. This value is not significant when “scaled” is chosen because it will be scaled to the amount needed by the melt based on the batch inlet flow rate, material properties, and the glass outlet temperature. Save the case after the setup has been completed.

Step 2. Open or create a new case with the same case number in the combustion domain just as would be done for a regular (non-calibration mode) simulation. When setting the values for items in the green boxes (displayed after clicking on the *Properties* → *Simulation Parameters* menu item), make sure the second line in the left-most green box shows “new start” and the bottom line in the same box shows “calc radiation”. The top line in the right-most box should show “melt surface: calculated” and the “initial iterations” line should show an iteration count set high enough to get an established flow field, about 600 iterations is reasonable.

Step 3. Click on the *Properties* → *Soot Kinetics* menu item. A drop-down list will appear with lines for soot formation and oxidation kinetic constants and activation energy, followed by another line: “Calibrate Soot Kinetics”.

Step 4. Click on one of the first four lines in the drop down list to pop up a window showing the current value of that parameter. Specify a new value if desired. Repeat for each of the parameters, going back to the *Properties* → *Soot Kinetics* menu item each time to get to the drop-down list. The algorithm used in the CFD program will adjust the soot formation kinetic constant while the soot oxidation kinetic constant is held constant. The adjustment is based on the user supplied fuel and air in flow rate and on the energy required by the melter. The correct fuel and air or oxygen flow rates can be determined by doing an energy balance on the furnace using a spread sheet. In addition, the output of the melt simulation in the “scaled” mode will provide detailed information on the energy requirements for the melt including heat losses from the melt through the walls. This

information can be used to determine what fraction of the heating value of the fuel must be transferred to the melt, which determines a baseline efficiency. The soot calibration procedure will tune the soot production kinetic parameter to match these conditions.

Step 5. Get back to the drop-down list. Click on “Calibrate Soot Kinetics” to activate the calibration mode. (Go back to the drop-down list again to see that the “Calibrate Soot Kinetics” line is now checked.) Save the case and get back to the main menu.

Step 6. Click on the *Simulation → Cycle Domains (Melt First)* menu item and proceed as explained in the GFM 4.0 Automated Cycling Guide document. Set the number of cycles to about 20 to 30 cycles.

Step 7. Monitor the soot_calnnnnc.plt file by clicking on the *Options → Activate RunPlot* menu item. The file will only be changed once per cycle, after the wall radiation has completed in the combustion domain. If the graphed line for *Aform* flattens out and the “HT to melt” line merges with the “E needed by melt” line, then the calibration run can be stopped. When there is a wide difference between plot lines, it may be difficult to see enough detail via **RunPlot**. If so, then look at the soot_calnnnnc.plt file directly, via **Notepad** or another text file viewer.

Step 8. After the simulation has stopped, if the *Aform* value has not settled down, then if it is oscillating due to overshooting and undershooting the energy needed in the melt, more cycles should be run until the *Aform* parameter has stabilized to 2 or more significant digits. If the amount of energy going to the melt is consistently too high, increase the value of the soot oxidation kinetic constant (see step 4 above) and change the soot formation kinetic constant to the latest value of *Aform*. Save the case and go back to step 6.

Step 9. When the *Aform* value has settled down, then set the values of the soot oxidation kinetic constant (see step 4 above) and the soot formation kinetic constant to the latest values of *Aoxid* and “*Aform*” from the soot_calnnnnc.plt file. Also click on the “Calibrate Soot Kinetics” item in the drop down list to uncheck it and turn off the soot calibration mode. Save the case. The procedure is done.

3. Adjust Relaxation Factors Procedure

Relaxation factors are used to slow the rate of change of variables in the iterative solvers. During the iteration process dampening is usually required so that large changes in one variable do not cause other variables coupled to the value of that variable to be adversely affected, possibly slowly spiraling out of control and causing the computation to diverge or oscillate wildly. When a new value for a variable is calculated, that value is actually replaced with a fraction (the relaxation factor) of the new value plus the complimentary fraction of the old value, thus lowering the value of a relaxation factor will reduce how much a variable can change during an iteration (which also may increase the number of iterations needed for convergence) and increasing the value of a relaxation factor will increase how much a variable can change during an iteration (which also may decrease the number of iterations needed for convergence). There is a balance required in finding relaxation factors that allow for convergence and do not unduly prolong the number of iterations needed to reach convergence. The default values work well for most cases. However, in cases that are particularly sensitive numerically, a simulation that does not converge well with the default values may achieve adequate convergence if the relaxation factors are adjusted.

Default relaxation factor values are provided for the combustion domain in the file `relaxfactorc.txt` in the combustion directory and for the melt domain in the file `relaxfactorm.txt` in the melt directory. These files are read by the CFD codes and hence apply to all cases. The information in these files is mapped into the tables below: file `relaxfactorc.txt` corresponds to Table 3.1 and file `relaxfactorm.txt` corresponds to Table 3.2. These tables show the direct association of relaxation factors to data that can be plotted via RunPlot (when such an association exists). Notice that each table is divided into 3 sections. The first 2 sections are for the relaxation factors and the third section is for the number of equation solver sweeps done for particular variables.

The number of solver sweeps controls the amount of computational work done by the low level linear solver routines during each global iteration through all of the governing equations. Using a very large number wastes computational resources because the coefficients are often functions of other variables or of the independent variable (for non-linear equations) and are therefore only known to limited precision that normally increases as the global iteration proceeds. Doing too much work during any one global iteration on a single equation can slow convergence because most of the solution precision gained in the solution step may be lost when the other equations are resolved and the values of coupling and independent variables in the coefficients change. However, using too few solver sweeps can result in too little progress being made in each iteration resulting in numerical oscillation and a simulation that never converges.

The Adjust Relaxation Factors procedure is usually done to reduce relaxation factors when the simulation run is not converging. However, it may also be used to increase the relaxation factors. One situation in which increasing the factors might be done is when there is a fairly well converged case that is going to be used as a base for several other

cases (such as when doing parametric studies) and increasing the relaxation factors might produce optimum values that can be used for a set of parametric runs reducing the number of days or weeks required to complete the parametric study. Care must be exercised under these circumstances to verify that each case in the parametric study has adequately converged. This procedure description focuses on reduction of the relaxation factors to obtain convergence in cases that do not converge adequately with the default values. In this procedure, “modify” and “reduce” means to manually edit the relaxfactor[c/m].txt file with a text editor such as **Notepad**, replacing the default value(s) only and keeping the rest of the file exactly as it was.

Step 1. Determine how to manage the relaxfactor[c/m].txt files. Remember that when a relaxfactor[c/m].txt file is changed, the change impacts all cases that will be run subsequently in the associated domain. If other cases already exist which might need to be rerun or restarted in the future, then it is advisable to make a copy of the relaxfactor[c/m].txt file, uniquely identifying it with a new name (possibly including the other case number or date in the name). In the future when one of the other cases is going to be rerun, then save the current relaxfactor[c/m].txt file with a new unique name, and rename the old file back to relaxfactor[c/m].txt.

Just as a precaution, a copy of each default relaxfactor[c/m].txt file, named base_relaxfactor[c/m].txt is kept in the documents directory. These files are backups that can be copied if the default files are needed again.

Step 2. Stop the run if it is still active. If the data collection flags were not turned on, then set up the simulation again with all the data collection flags turned on and repeat the run. Stop the run at about the same number of iterations as before.

Step 3. Examine convergence data via **RunPlot**. The governing equation residuals provide the primary indicators of convergence. The residuals are normalized by the largest term for each computational cell and averaged over all cells in the grid. For most variables, the residuals should drop below 10^{-3} . The exceptions are some of the minor species. Mass fractions for some of these variables are very small and even negligible over most of the computational cells. The normalized mean for these variables, therefore, may reflect a value dominated by residuals from cells that have essentially none of the species present. Methane, oxygen, and NO, for example, typically do not have mean residuals below 10^{-3} in the minor species residuals plot. For most variables, however, if the mean residual plot is not dropping below 10^{-3} , then reducing the relaxation factors for the variables that do not meet these criteria may allow the computation to converge. Also try to determine if any specific variables are erratic or just not moving in the desired direction. If so, then reducing the relaxation factors for those variables may help. If specific variables cannot be identified as causing a problem, then reduce all the relaxation factors in the first section of the relaxation file may resolve the problem.

Relaxation factors can be safely cut in half. The penalty for making relaxation factors too small is slower convergence (more computation time for a simulation). If settings are found that achieve convergence for an otherwise unstable simulation, they can be

increased to speed up the computation for parametric runs as long as convergence is maintained.

Step 4. Setup and run the simulation again. If the simulation converges then exit this procedure.

Step 5. Try each of the alternatives below in turn. Setup and run the simulation again each time. If the simulation is converging then exit this procedure.

1. Reduce all the relaxation factors in the second section of the relaxfactor[c/m].txt file.
2. Reduce all relaxation factors a second time.
3. Increase the number of solver sweeps in the third section of the relaxfactor[c/m].txt file.

The number of solver sweeps can have a dramatic effect on convergence level as measured by the mean residual. It also has a dramatic effect on computation time. Because two or more orders of magnitude of convergence in driving down the residuals may be lost in the perturbations caused by changes in coupling variables over the course of a global iteration through the solver for all of the governing equations or in cycling between combustion and melt spaces, the computational cost of driving residuals down more than a few orders of magnitude may not produce any significant gains. Experimentation with the number of solver sweeps can help to find optimum values.

Step 6. Go through each of the relaxation factors one by one, reduce the factor by a significant amount and increase the solver sweeps by a significant amount, and redo the simulation. Restore the factor to its previous value if there is no change in the simulation results.

Table 3.1: Combustion Relaxation Factors		
Default Value	Item to Relax	Data to Check via RunPlot
Relaxation factors for equation loops		
0.7d0	general value	
0.7d0	equation for fuel mass fraction	Fuel in gresid_xtra####c.plt file
0.7d0	equation for oxygen	O2 in gresid_xtra####c.plt file
0.7d0	equation for enthalpy	Enthalpy gresid####c.plt file
0.7d0	equation for turbulent kinetic energy	k in gresid_xtra####c.plt file
0.7d0	equation for turbulent dissipation rate	Epsilon in gresid_xtra####c.plt file
0.7d0	equation for carbon dioxide	CO2 in gresid_xtra####c.plt file
0.7d0	equation for nitrogen	N2 in gresid_xtra####c.plt file
Relaxation factors for certain variables		
0.7d0	general value	
0.3d0	u momentum in x direction (pressure	
0.3d0	v momentum in y direction (pressure	
	w momentum in z direction (pressure	
0.3d0	correction)	
0.6d0	density	
0.6d0	reaction rate	
0.7d0	initial surface heat flux	
0.9d0	minor species	all but last heading in mresid####c.plt file
0.7d0	soot	Soot in mresid####c.plt file
Number of sweeps in equation solver for specified items		
2	general value	
2	u momentum in x direction	x-momentum in gresid####c.plt file
2	v momentum in y direction	y-momentum in gresid####c.plt file
2	w momentum in z direction	z-momentum in gresid####c.plt file
6	pressure	Pressure in gresid####c.plt file
5	pressure correction	
2	fuel	Fuel in gresid_xtra####c.plt file
3	co2	CO2 in gresid_xtra####c.plt file
10	enthalpy	Enthalpy in gresid####c.plt file
2	turbulent kinectic energy	k in gresid_xtra####c.plt file
2	epsilon	Epsilon in gresid_xtra####c.plt file
3	n2	N2 in gresid_xtra####c.plt file
3	o2	O2 in gresid_xtra####c.plt file
1	minor species	all but last heading in mresid####c.plt file

Table 3.2: Melt Relaxation Factors		
Default Value	Item to Relax	Data to Check via RunPlot
Relaxation factors for equation loops		
0.4d0	default value	
0.4d0	u momentum in x direction	x-momentum in gresid####m.plt file
0.4d0	v momentum in y direction	y-momentum in gresid####m.plt file
0.4d0	w momentum in z direction	z-momentum in gresid####m.plt file
0.4d0	enthalpy	Enthalpy in gresid####m.plt file
1.0d0	electric potential energy	
0.5d0	melt rate	
Relaxation factors for certain variables		
0.3d0	default value	
0.3d0	u momentum in x direction (pressure correction)	
0.3d0	v momentum in y direction (pressure correction)	
0.3d0	w momentum in z direction (pressure correction)	
0.0d0	place holder	
0.0d0	place holder	
0.3d0	particle number density	
0.3d0	particle temperature	
0.3d0	density	
0.3d0	melt rate	
0.2d0	relaxation factor for surface temperature	
0.3d0	down scaling factor for heat transfer from melt surf back into combustion space	
Number of sweeps in equation solver for glass		
2	default value	
2	u momentum in x direction	x-momentum in gresid####m.plt file
2	v momentum in y direction	y-momentum in gresid####m.plt file
2	w momentum in z direction	x-momentum in gresid####m.plt file
2	pressure	Pressure in gresid####m.plt file
4	pressure correction	
2	enthalpy	Enthalpy in gresid####m.plt file
2	electric potential energy	

Appendix 2

GFM 4.0 Graphical User Interface Menus

The tables below list and specify the purpose of the three highest levels in the GFM menu system. A “(C)” following a menu item indicates that the item is only present when the user is in the combustion space domain. Likewise, an “(M)” following a menu item indicates that the item is only present when the user is in the melt space domain.

Main Menu

Menu Item	Sub-Item	Purpose
Pre-Processor		Prepare the inputs required by the GFM CFD application code.
	Combustion Space	Select the combustion space domain.
	Glass Melter	Select the melt domain.
Simulation		Run and monitor the simulation.
Post-Processor		Examine the simulation output.
	Combustion Space	Select the combustion space domain.
	Glass Melter	Select the melt domain.
Screen Print		Create a bitmap file of the screen display.
Exit		Shut down the GFM program and leave the GUI.
Help		View the GFM documentation.

Initial Preprocessor Menu

Menu Item	Sub Item	Purpose
File		
	New Case	Create a new case using default settings and display its figure view.
	Open Case	Open an existing case and display its figure view.
	Save Case	Disabled.
	Save Case As (Setup Only)	Disabled.
	Save Case As (Full Case)	Disabled.
	Update Case Description	Disabled.
	Delete Case	Delete the files for a given case.
	Delete Case Results	Delete only the output files for a given case.

Screen Print		Create a bitmap file of the screen display.
Done		Return to main menu.
Help		View the GFM documentation.

Preprocessor Menu When a Case is Open

Menu Item	Sub Item	Purpose
File		
	New Case	Disabled.
	Open Case	Disabled.
	Save Case	Save the new or modified setup files for the current case, constructing the grid if it was modified or did not exist before.
	Save Case As (Setup Only)	Make a copy of the setup portion of the current case using a new case number.
	Save Case As (Full Case)	Make a copy of the current case using a new case number.
	Update Case Description	Change or add to the case notes.
	Delete Case	Disabled.
	Delete Case Results	Disabled.
View		Change between the figure and grid views (only present after a grid exists).
Construct		
	Geometry	Set interior dimensions for furnace.
	Burner (C)	Define inlets for fuel and oxygen.
	Charger (M)	Define inlets for batch and/or cullet.
	Exhaust (C)	Define exits for combustion products.
	Outlet (M)	Define exits for melted glass.
	Components (C)	Define doghouses (side wells).
	Components (M)	Define electric boosters and/or gas bubblers.
	Grid	Construct the simulation grid.
Properties		
	Emissivities (C)	Specify emissivity for side walls, ceiling, and /or melt surface.
	Glass Exit Temperature (M)	Set the temperature of melted glass at the exit.
	Glass Properties (M)	Provide linear function points for the glass melt physical properties.
	Wall Properties	Set the wall physical properties.
	Simulation Parameters	Set the simulation run parameters.
	Soot Kinetics (C)	Indicate whether the simulation run will be for doing a soot kinetic calibration and specify soot kinetic parameters.
	Radiation Controls (C)	Indicate how view factors are kept and

		modify radiation solver loop limits.
Options		
	Simulation Display Updates	Turn on or off the refresh of the plot view during simulation.
	Collect Run Data	Identify the types of data that will be collected during the simulation run.
	Units	Change between SI and British unit representation on the display.
	Feed Units (C)	Indicate whether volume or mass based feed units are being used on the display.
	Zoom	Adjust the size of the diagram displayed on the screen.
	Diagram Position	Adjust the lower left corner position of the diagram displayed on the screen.
	Protect Grid Edits	See the status of the “protect grid edits” mode and change if desired.
Screen Print		Create a bitmap file of the screen display.
Done		Return to main menu.
Help		View the GFM documentation.

Grid Construction Menu

Menu Item	Sub Item	Purpose
File		
	New Case	Disabled.
	Open Case	Disabled.
	Save Case	Save the new or modified setup files for the current case, constructing the grid if it was modified or did not exist before.
	Save Case As (Setup Only)	Make a copy of the setup portion of the current case using a new case number.
	Save Case As (Full Case)	Make a copy of the current case using a new case number.
	Update Case Description	Change or add to the case notes.
	Delete Case	Disabled.
	Delete Case Results	Disabled.
View		Change between the figure and grid views (only present after a grid has been constructed).
Options		
	Simulation Display Updates	Turn on or off the refresh of the plot view during simulation.

	Collect Run Data	Identify the types of data that will be collected during the simulation run.
	Units	Change between SI and British unit representation on the display.
	Zoom	Adjust the size of the diagram displayed on the screen.
	Diagram Position	Adjust the lower left corner position of the diagram displayed on the screen.
	Protect Grid Edits	See the status of the “protect grid edits” mode and change if desired.
Screen Print		Create a bitmap file of the screen display.
Done		Return to main menu.
Help		View the GFM documentation.

Simulation Menu

Menu Item	Purpose
Combustion Space	Start a combustion simulation run.
Glass Melter	Start a melt simulation run.
Cycle Domains (Comb First)	Start a combustion simulation run and automatically cycle runs between the two domains.
Cycle Domains (Melt First)	Start a melt simulation run and automatically cycle runs between the two domains.
Cycle Regenerative (Comb First)	Start a combustion simulation run, automatically simulate the alternate furnace configuration to get an average heat flux for input to the melt simulation, and cycle runs between the two domains.
Cycle Regenerative (Melt First)	Start a melt simulation run and automatically cycle runs between the two domains, using the average heat flux from simulation of the two furnace configurations.

Running Simulation Menu

Menu Item	Sub Item	Purpose
File		
	New Case	Disabled.
	Open Case	Disabled.
	Save Case	Disabled.
	Save Case As (Setup Only)	Disabled.
	Save Case As (Full Case)	Disabled.
	Update Case Description	Change or add to the case notes.
	Delete Case	Disabled.
	Delete Case Results	Disabled.
Options		
	Simulation Display Updates	Turn on or off the refresh of the plot view during simulation.
	Activate RunPlot	Start up the RunPlot program to display a line graph for particular data collected.
	Units	Change between SI and British unit representation on the display.
	Zoom	Adjust the size of the diagram displayed on the screen.
	Diagram Position	Adjust the lower left corner position of the diagram displayed on the screen.
Screen Print		Create a bitmap file of the screen display.
Stop Run		Stop the simulation run.
Help		View the GFM documentation.

Post Processor Menu

Menu Item	Sub Item	Purpose
File		
	New Case	Disabled.
	Open Case	Select case and display first output property. (Disabled after use.)
	Save Case	Disabled.
	Save Case As (Setup Only)	Disabled.
	Save Case As (Full Case)	Disabled.
	Update Case Description	Change or add to the case notes.
	Delete Case	Disabled.
	Delete Case Results	Disabled.
Options		
	Activate RunPlot	Start up the RunPlot program to display a

		line graph for particular data collected.
	Units	Change between SI and British unit representation on the display.
	Zoom	Adjust the size of the diagram displayed on the screen.
	Diagram Position	Adjust the lower left corner position of the diagram displayed on the screen.
	Plot	Modify the output plot view.
Screen Print		Create a bitmap file of the screen display.
Done		Return to the main menu.
Help		View the GFM documentation.

Appendix 3

Using the GFM 4.0 Graphical User Interface to Build, Run, and Review Models: Two Examples

Introduction

When you enter the GFM GUI you will see the GFM welcome screen which identifies the program and shows a picture of the inside of a glass furnace. The most important item on the screen is the main menu bar located at the top of the screen just beneath a standard window style title bar. By clicking on the menu items you can enter into any of the three GFM GUI environments:

1. **Pre-Processor** – where you prepare the inputs required by the GFM CFD application code
2. **Simulation** – where you run and monitor the simulation
3. **Post-Processor** – where you examine the simulation output.

These environments are kept separate; you must return to the welcome screen to move between these environments. Environments are designed so that you can perform your work in one session or do some of your work, save it, exit the GUI, and return at a later session to continue work on the same or on a different furnace.

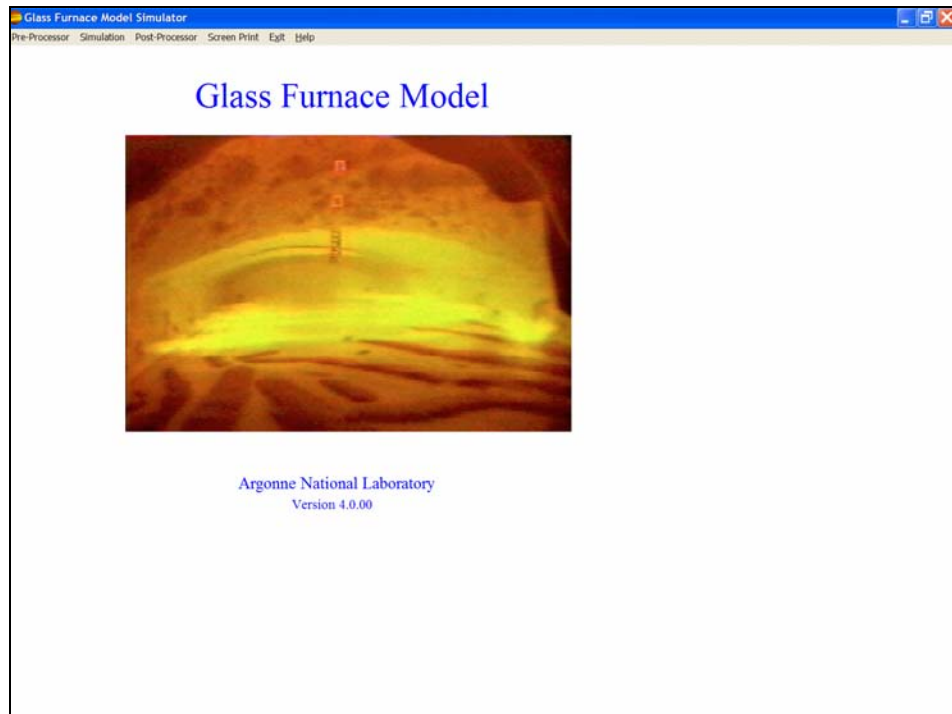

Figure 1. Welcome Screen

Key Terms

Flow Domain. A glass furnace is divided into two distinct flow domains: the upper combustion space and the lower melt space. Usually in this document the word “furnace” refers to the half furnace associated with a specific flow domain. The GFM GUI deals with each of these domains separately and the GFM CFD application has both a combustion code and a melt code used to simulate a furnace. Files created and used by the GUI are kept in either a “combustion” or a “melt” subdirectory for the appropriate flow domain. Most filenames will contain either a “c” or “m” to identify their association with the combustion and melt flow domains respectively.

Case. Each simulation for a given furnace configuration and set of run conditions is identified by a case number. The GFM GUI operates on a case basis rather than on an individual file basis. The case creation, modification, and saving of case data are menu actions within the combustion and melt environments. Corresponding combustion and melt geometries and conditions that are going to be run as a coupled simulation (where melt surface conditions are exchanged between the simulations of the combustion and melt space) must be assigned the same case number by the user. All the files associated with a case will contain the case number within the filename.

Short Work Flow Step List

Example 1: Create a new case from scratch, Simulate a new furnace design

Start GFM.

In the Pre-Processor environment:

1. Select flow domain and create a new case with default furnace.
2. Adjust furnace dimensions.
3. Modify/add furnace objects (burners, exhausts, etc.).
4. Specify physical properties and simulation run parameters.
5. Build the grid.
6. View the grid.
7. Optionally enhance the grid with hand edits.
8. Save the case.
9. Leave the Pre-Processor environment.

In the Simulation environment:

10. Select flow domain and an existing case to start up a CFD simulation.
11. Monitor the simulation run.
12. Use additional monitoring capability.
13. Leave the simulation environment

In the Post-Processor environment:

14. Select flow domain and an existing case.
15. Look at the simulation output
16. Leave the Post-Processor environment.

Exit GFM.

Example 2: Create a new case from a previous case, Simulate same furnace with different run parameters

Start GFM.

In the Pre-Processor environment:

1. Select flow domain and open previous case.
2. Save copy of previous case as a new case.
3. Adjust simulation run parameters.
4. Return to main menu and proceed with simulation and post processing as was done in creating a new case from scratch.

Exit GFM.

Example 1: Create a New Case from Scratch,

Simulate a New Furnace Design

Start GFM

In Pre-Processor environment:

1. Select flow domain and create a new case with default furnace.
 - From the main menu click on ***Pre-Processor*** to display the submenu showing the domain choices.
 - Click on the ***Combustion Space*** or the ***Glass Melter*** menu item to choose the flow domain you want to work in. This action displays a blank screen with the Pre-Processor menu bar.
 - Click on the ***File*** menu item to display the ***File*** submenu items.
 - Pass mouse over the ***File*** → ***New Case*** menu item to get to the submenu showing the choices for the shapes of the furnace. For the combustion flow domain click on either the ***Box*** or ***Crown Top*** item. For the melter flow domain click on either the ***Melter*** or ***Melter with Refiner*** item. This action pops up a “Create New Case” dialog window listing the cases already in the appropriate directory, “combustion” or “melt”.
 - Enter the new case number and click ***OK*** to create the case folder and to pop up a “Case *nnnn* Description” dialog window requesting that you enter a title and description of the case
 - Enter a short, single line title and/or a multi-lined description for the new case. . (You may leave these items blank; they are optional for your use.) Click ***OK***. This action gets rid of the pop-up and displays a figure outline of a default furnace. The figure is not shown to exact scale. The default combustion furnace has one burner labeled b1 and one exhaust, e1. The default melt furnace has one charger labeled c1 and one outlet, o1.
 - For the melter with refiner default furnace, the figure has two parts. The upper part shows the full melter with throat and refiner components. The lower part shows one component at a time.
 - The screen with the figure is called the **figure view**.

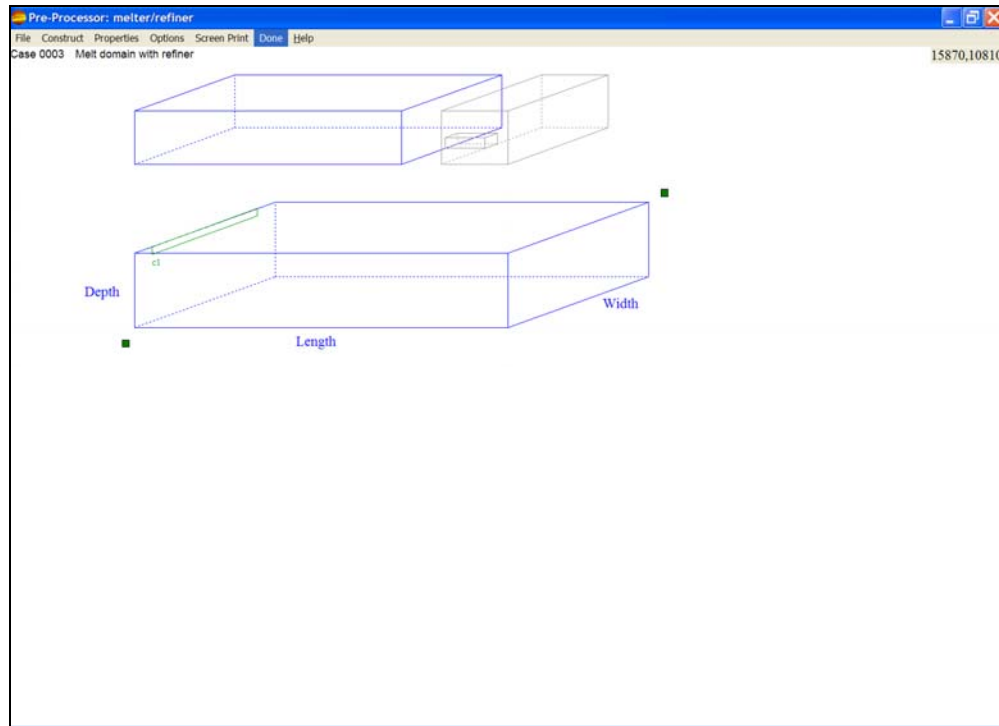

Figure 2. Initial Sample Figure View Showing Melter with Refiner

- Now that the case has been created:
 - **Construct**, **Properties**, and **Options** menu items have been added to the menu bar.
 - The **Update...** and **Save...** submenu items under the **File** menu item have become active while the other submenu items have become inactive. Even though you just have a default figure on the screen, it does represent a savable case.
 - The case number and title appear on the upper left of the screen display area under the menu bar. This information with the case description has also been stored in the case $nnnn$ [c|m].txt file, where $nnnn$ is the case number.
 - The small green box near the upper right of the figure is a handle that you can grab by holding down with the left mouse button and drag to enlarge or diminish the figure size. An alternative to adjusting the figure size is to use the **Options** → **Zoom** menu item.
 - The small green box near the lower left of the figure is a handle that you can grab by holding down with the left mouse button and drag to reposition the figure. An alternative to adjusting the figure position is to use the **Options** → **Diagram Position** menu item.
 - The current mouse coordinates are shown in the upper right corner of the screen. Knowing how to identify a point on the screen may help you to position the figure. The figure's reference position is the lower left corner of its box.

2. Adjust furnace dimensions

- Dimension values are for the interior of the furnace without the walls.
- By default the units are in the SI (metric) system. You may change to the British system by clicking the desired unit system item under the **Options** → **Units** menu item.
- The dimension labels on the figure are active. Click on one of them to see the dimension highlighted in red and to get a pop up window in which you can enter a new value. After one dimension is changed, a green geometry list box displays on the lower left of the screen showing all the dimensions with values. For the melter with refiner, the geometry list box consists of multiple boxes. Click on the component names in the first box to choose which component will be displayed in the lower part of the figure.
- Alternatively, clicking on the **Construct** → **Geometry** menu item will also display the geometry list box.
- Clicking on any item in the geometry list box or dimension label on the figure will allow you to change that dimension value via a popup input box.

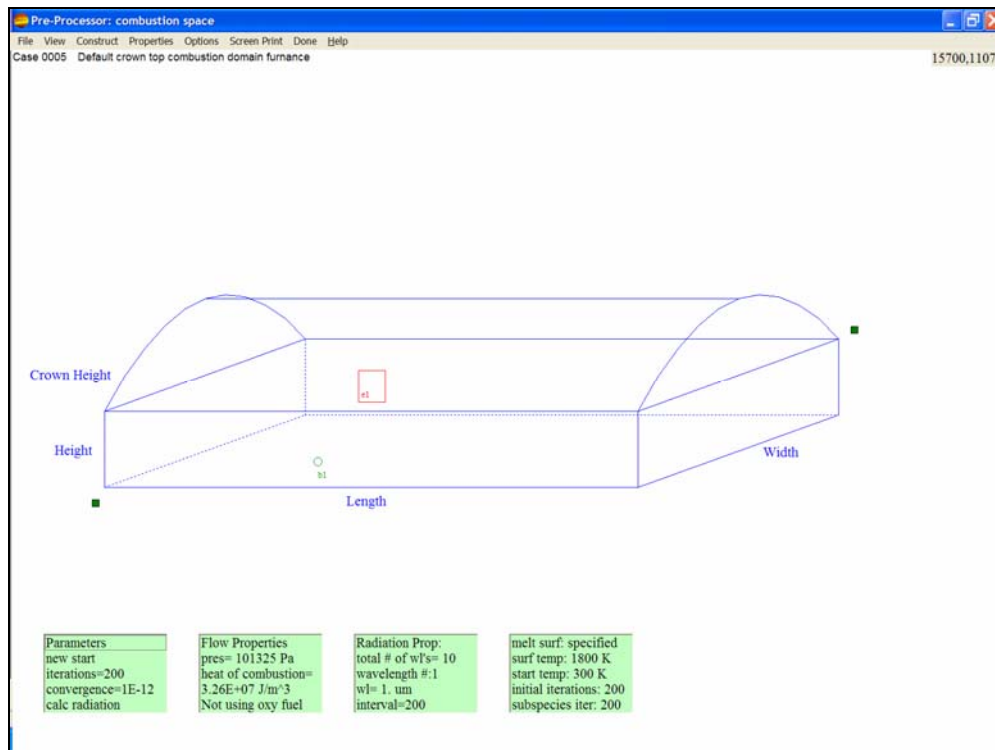

Figure 3. Combustion Figure View with the Green List Boxes

3. Modify/add furnace objects (burners, exhausts, etc.).

- Submenu of combustion space furnace objects:
 - **Construct** → **Burner** (inlet)
 - **Construct** → **Exhaust** (exit)
 - **Construct** → **Components** → **Dog House** (Warning: feature not validated)

- Submenu of melt space objects:
 - *Construct* → *Charger* (inlet)
 - *Construct* → *Outlet* (exit)
 - *Construct* → *Components* → *Bubbler* (Warning: feature not validated)
 - *Construct* → *Components* → *Electric Booster* (Warning: feature not validated)
 - Click on any of the object submenu items to get to the list box for that object where you can add, delete, relocate, resize, or change properties associated with the object. Alternatively, click on the top line of the list box to go to the next construct menu item. Note that the list box changes for each object and additional boxes are added to the right of the first list box as needed for a given item. Update the values in the list boxes as desired.
 - Clicking on the second line in the leftmost list box will get to the next object of the type identified in the first line of the list box.
 - The list box lines function in a variety of ways when clicked and some changes may cause other lines to also be changed:
 - An input box pops up so that you can see the current value and modify it.
 - The value of the line changes to the next value within a predetermined set of valid values.
 - Nothing happens; the line is just a heading.
4. Specify physical properties and simulation run parameters
- Submenu of combustion space properties:
 - *Properties* → *Emissivities*
 - *Properties* → *Wall Properties*
 - *Properties* → *Simulation Parameters*
 - *Properties* → *Soot Kinetics*
 - *Properties* → *Radiation Controls*
 - Submenu of melt space properties:
 - *Properties* → *Glass Exit Temperature*
 - *Properties* → *Glass Properties*
 - *Properties* → *Wall Properties*
 - *Properties* → *Simulation Parameters*
 - Click on the *Properties* submenu items and update the values as needed. The submenu items function in a variety of ways when clicked:
 - Another level of menu items appears.
 - An input box pops up so that you can see the current value and modify it.
 - The value of the line changes to the next value within a predetermined set of valid values.
 - The item toggles between being checked and unchecked.
 - Green list boxes appear on the bottom of the screen. Update as needed.
 - Choose whether or not the simulation progress will be displayed on the screen (approximately every half minute). Click on either the “Simulation Progress Display On” or “Simulation Progress Display Off” item under the *Options* → *Simulation Display Updates* menu item.

- Click on the **Options** → **Collect Run Data** menu item to pop up a list of the types of data to collect during the simulation run. Click an entry to check or uncheck which data to collect.
5. Build the grid
- Click on the **Construct** → **Grid** menu item. This action causes the grid to be built and displayed on the screen. The screen display is called the **grid view**.

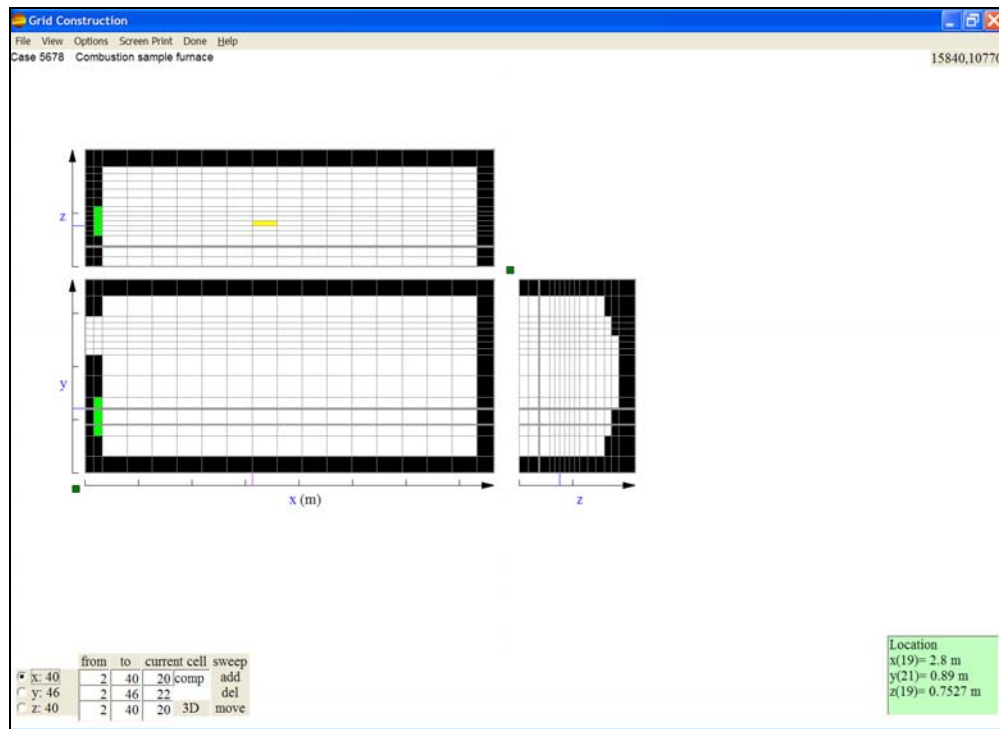

Figure 4. Sample Grid View

- Note the following changes to the screen display:
 - The figure is changed to a set of three flat grid planes, one for each dimension, going thru the center cell (determined by grid index, not physical position). The cells are color coded:
 - White for open to flow computational cells
 - Black for walls
 - Cyan for glass melt surface
 - Light green for inlets
 - Bright red for exits
 - Dark red for electric boosters (melt space only)
 - Dark green for bubblers (melt space only)
 - The **Construct** menu item is not present in the grid view.
 - After a grid is constructed a new **View** menu item appears in both the figure and grid views to allow switching between the figure view and the grid view

so that you can see how changes in the figure are reflected in the grid. Remember that the grid will need to be reconstructed before changes made to the figure are reflected in the grid.

- A **Grid Density** submenu appears in the **Options** menu item. Initially, the grid is built with uniform spacing except for specific grid lines required for object positioning. Optionally use the **Grid Density** submenu to make the grid denser or courser in all or individual directions. A courser grid will shorten the simulation time and a denser grid will lengthen the simulation time. However, a denser grid may be required for accuracy and to resolve flow features, such as recirculation zones within the flow field.
- A grid control block replaces the list boxes from the figure view in the lower left corner of the screen.
- The location of the current cell is given in grid index values and positions are given as distances from the lower left corner of the grid. These values are displayed in a box in the lower right corner of the screen. The current cell is colored yellow in the grid. The current cell, whose indexes and position are displayed, can be changed by merely clicking on the cell you want to make current. This action causes the displayed grid planes to change so that they intersect the new current cell.

6. View the grid.

- You can change how you see the grid by clicking on any of the visible cells to change the current cell to the clicked cell. Or you could change the planes being displayed by clicking in the white space between the grid and any of the labeled axes.
- You can change the unit type via the **Options** → **Units** menu item or you could click on the unit designation displayed on the x axis label.
- Look at the grid control block; it will help you view the grid. Consider the block as being a table with rows and columns.
 - Column 1 (leftmost) has a radio button for each direction with the associated maximum cell index in that direction. (Cell indexes are even, Cell faces have odd indexes). The active direction radio button is pressed. You can click on these buttons to change the active direction.
 - Column 2 shows the beginning cell indexes.
 - Column 3 shows the ending cell indexes.
 - Column 4 shows the current cell indexes.
 - Column 5 shows the current cell type and color in the second row and a dimension indicator in the fourth row. You can click on this indicator to change between the flat **2D** and grid slices in a **3D** view.
 - Column 6 shows a set of grid controls. These controls will vary between the GUI environments. Use the top control **sweep** at this step. Clicking **sweep** automatically displays successive grid planes in the current direction in either **2D** or **3D** slices and changes the control label to **stop**. When you want to stop the sweeping, click **stop** and the label will change back to **sweep**.
- Changing values of beginning and ending cell indexes in columns 2 and 3 of the grid control block allows zooming in on portions of the grid by clipping the

displayed portion to these limits. The resize handle at the upper right of the xy-plane can be dragged to enlarge the view of the clipped region.

- Switch back and forth between the figure view and grid view as needed to assist in modifying the grid to best represent the furnace.

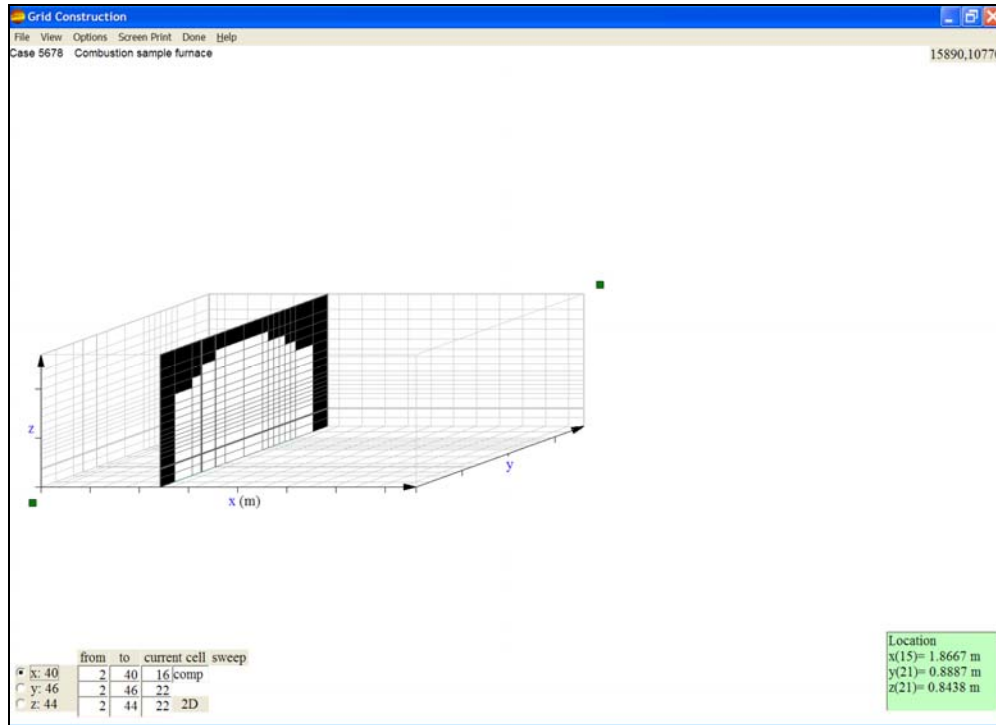

Figure 5. Sample Grid View in 3D Mode

7. Optionally enhance the grid with hand edits.

- Enhancements include adding, deleting, and moving individual grid lines. They also include changing grid cell types.
- Examples of why you might want to enhance a grid:
 - You are particularly interested in the flow pattern near a specific grid object. Then you would add more grid lines in that neighborhood to get more details of the flow there.
 - You know the simulation will take a long time. There is a region of the furnace that is devoid of objects and flow pattern, temperature, etc. are expected to change slowly with distance. Then the grid can be made coarser in this region by deleting some of the grid lines in this region to speed up the simulation.
 - The furnace contains a shelf or baffle. You need to represent those items by changing the associated grid cells from the open cell type to the wall type.
- To add a grid line, select the current cell and direction of the add by clicking one of the x, y, or z radio buttons in column 1 of the grid control block. Note that this direction choice determines the orientation of the grid line to be added. Then click

- the **add** control in column 6 of the grid control block. This action puts a new grid line thru the middle of the current cell.
- To delete a grid line, select the current cell and direction of the delete by clicking one of the x, y, or z radio buttons in column 1 of the grid control block. Note that this direction choice determines which grid line will be deleted. Then click the **del** control in column 6 of the grid control block. This action deletes the grid line that was the lower index of the current cell for the given direction.
 - To move a grid line between the current and the previous cell, select the current cell and the direction of the move by clicking one of the x, y, or z radio buttons in column 1 of the grid control block. Note that this direction choice determines which grid line will be moved. Then click the **move** control in column 6 of the grid control block. This action will highlight in yellow the 2 grids lines that you will be moving between and it will pop up a box in which you can specify the location you want the line to be moved to between the highlighted lines.
 - To change the current cell type, click on the control in column 5 row 2 until the desired type appears.
 - To change the cell type of a block of cells:
 - a. Click on the **current cell** label on the top of columns 4 and 5. It will change to **select cells**.
 - b. Move the current cell to the desired beginning location (which is the lower left corner of the block you want to change) and click the **from** label on the top of column 2.
 - c. Move the current cell to the desired ending location (which is the upper right corner of the block you want to change) and click the **to** label on top of column 3.
 - d. Click the desired cell type in column 5.
 - e. Click the **select cells** label. It will change back to **current cell**.
 - Note that the inlet cell type should not be changed. Inlets are determined by the positions of the burners in combustion flow and of chargers in the melt flow as indicated by the information from the figure view. Go back to the figure view to change inlets.
 - Note that the exit cell type should not be changed. Exits are determined by the positions of the exhausts in combustion flow and of outlets in the melt flow as indicated by the information from the figure view. Go back to the figure view to change exits.
 - Up to this step the information for the figure and grid has been kept consistent. However with hand edits, the grid information diverges from the figure information and the grid cannot be reconstructed without destroying the hand edits. But, you can still switch between views and modify parameters and properties.
 - The GUI will warn you about this situation when you attempt to make your first enhancement to the grid. It will also put the pre-processor into Protect-Grid-Edits mode as indicated by the **Options → Protect-Grid-Edits** menu item being checked. In this mode, modifications which would require the grid to be constructed are disabled. You may get out of the protect mode by clicking the **Options → Protect-Grid-Edits** menu item to uncheck it.

8. Save the case.
 - Click on the **File** → **Save Case** menu.
 - If the grid is not enhanced and the grid has been modified after being constructed, then the GUI will reconstruct the grid.
 - The GUI creates three files (where *nnnn* is the case number and “c” is changed to “m” for the melt flow domain):
 - pre-process file, *gdnnnnc.pre*. This file is needed if you ever want to change information in the figure view again.
 - grid file, *gdnnnnc.dat*. This file is required input to the GFM CFD code.
 - conditions file, *sbcnnnnc.dat*. This file is required input to the GFM CFD code.
 - In the combustion domain, the GUI will create a default information transfer file, *itnnnnt.dat*, when the melt surface temperature had been specified in the rightmost **Simulation Parameters** green list box. An *itnnnnt.dat* file is created during a melt domain simulation run; it will contain the calculated melt surface temperature.
 - In the melt domain, the GUI will create a default information transfer file, *itnnnntm.dat*, when a uniform heat flux had been specified in the rightmost **Simulation Parameters** green list box. An *itnnnntm.dat* file is created during a combustion domain simulation run; it will contain the calculated melt surface heat flux.

9. Leave the Pre-Processor environment.
 - Click on the **Done** menu item to return to the main GUI menu.

In the Simulation environment:

10. Select flow domain and an existing case to start up a CFD simulation.
 - From the main menu click on **Simulation** to display the submenu showing the domain choices.
 - Click on the **Combustion Space, Melter**, or one of the **Cycle** menu items to choose the type of simulation to run. (For information about cycling, click on the **Help** menu and then on the “Cycling” item in the pop-up box.) This action pops up a “Select Existing Case to Simulate” dialog window listing the cases already in the appropriate directory, “combustion” or “melt”.
 - Select the previous case you saved in the Pre-Processor by clicking on its filename and click **Simulate** to start the simulation. This action also brings up a new screen display that is similar to the grid view with the following changes:
 - The **View** menu item is deleted from the menu bar.
 - The **File** and **Options** submenus have fewer active items.
 - The **Done** menu item is replaced by the **Stop Run** menu item.
 - The location box from the lower right corner has been removed.
 - A status box (actually two boxes) is displayed at the bottom center of the screen indicating that the simulation is being initialized.
 - The grid controls in column 6 of the grid control block have changed.

11. Monitor the simulation run.

- As soon as the CFD simulation has been initialized and is reporting status information to the GUI, the grid on the screen display is replaced with a colored plot of the temperature or radiation energy in the simulated furnace and more status information is displayed in the status box. This screen display is the **plot view**. It is frequently updated while the simulation runs – for minutes, hours, or days depending on the complexity and size of the furnace and the density of grid cells.
- Note that if the “Simulation Progress Display Off” item under the *Options* → *Simulation Display Updates* menu item has been checked, then the grid will not be replaced with the colored plot and status information will not be displayed in the status block. You can change the display off and on while the simulation is running. Turning the display off will speed up the simulation.
- You can change the plot from color to black and white by clicking the *B/W* control in column 6 of the grid control block. Then you can change the plot back to color by clicking the control again when it is labeled *color*.
- You can show the grid temporarily rather than the plot by clicking the *grid* control in column 6 of the grid control block. You can change the current cell position, as you could on a grid view in the pre-processor, to see different planes thru the plot.
- You can pause the plot by clicking on the *pause* control in column 6 of the grid control block and then allow it to be updated again by clicking the (same) *auto* control. One thing you might want to do while the plotting is paused is to click on the *Screen Print* menu item to make a bitmap file of the screen display without having the plot changed during the screen capture.
- The CFD simulation normally ends when either the convergence criteria or the maximum number of iterations (previously specified as parameters on the figure view) has been met. Then the small box in the upper right corner of the grid control block will turn bright green and show the *cont* label (meaning continue). The *Stop Run* menu item will also change to *Done*.
- You could decide to stop the simulation earlier by clicking the *Stop Run* menu item or the *stop* label in the upper right corner of the grid control block. The grid control will change to *ending* after the request to stop the simulation has been sent from the GUI to the CFD simulation. The label will be changed to *cont* after the GUI recognizes that the CFD code has stopped.

12. Use additional monitoring capability.

- When the CFD code is running, a command prompt window will exist for the combustion or melt executable program. This window is normally minimized to a small icon entry on the bottom bar of the screen. If this window does not exist, then you know that the CFD code is not running. You can maximize the window to see ongoing status information.
- Click on the *Options* → *Activate RunPlot* menu item to start up the RunPlot program which will display lines for various data collected during the simulation. Note that you could specify what extra data to collect when you were in the Pre-Processor environment and clicked on the *Options* → *Collect Run Data* menu item.

- You may start up multiple instances of the RunPlot program. (For information about this program, click on the *Help* menu and then on the “RunPlot” item in the pop-up box.)

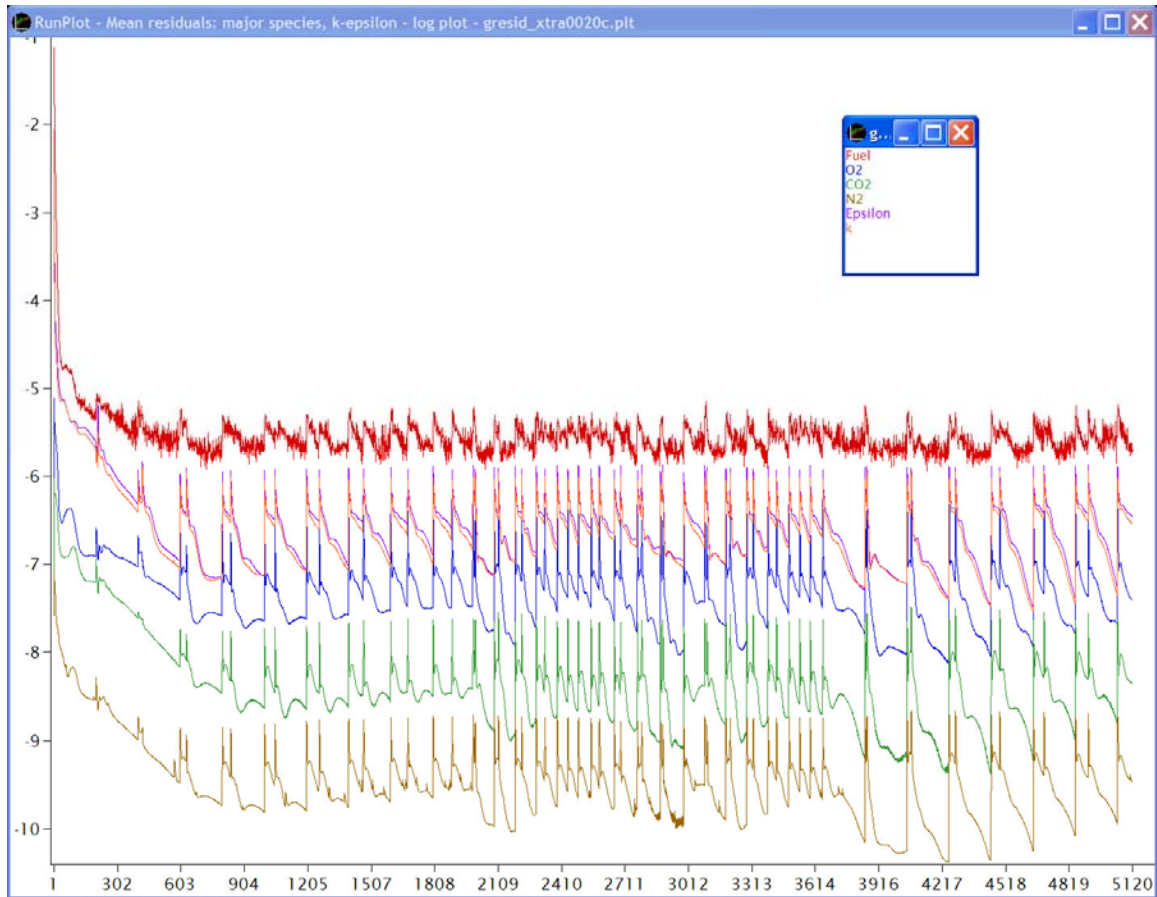

Figure 6. Sample RunPlot Logarithmic Display with Legend Window Superimposed

13. Leave the simulation environment.

- When you see the small green box with *cont* you can restart the simulation run (to continue from where it stopped) by clicking the *cont* or you can return to the main menu by clicking the *Done* menu item.

In the Post-Processor environment:

14. Select flow domain and an existing case.

- From the main menu click on *Post-Processor* to display the submenu showing the domain choices.
- Click on the *Combustion Space* or the *Melter* menu item to choose the flow domain you want to work in. This action pops up an Open dialog window listing the cases already in the appropriate directory, “combustion” or “melt”.

- Select the previous case you simulated by clicking on its filename and click **Open** to load the simulation results. This action also brings up the **plot view** screen display with the following changes:
 - The **File** submenu allows you to open up a different case to look at simulation outputs.

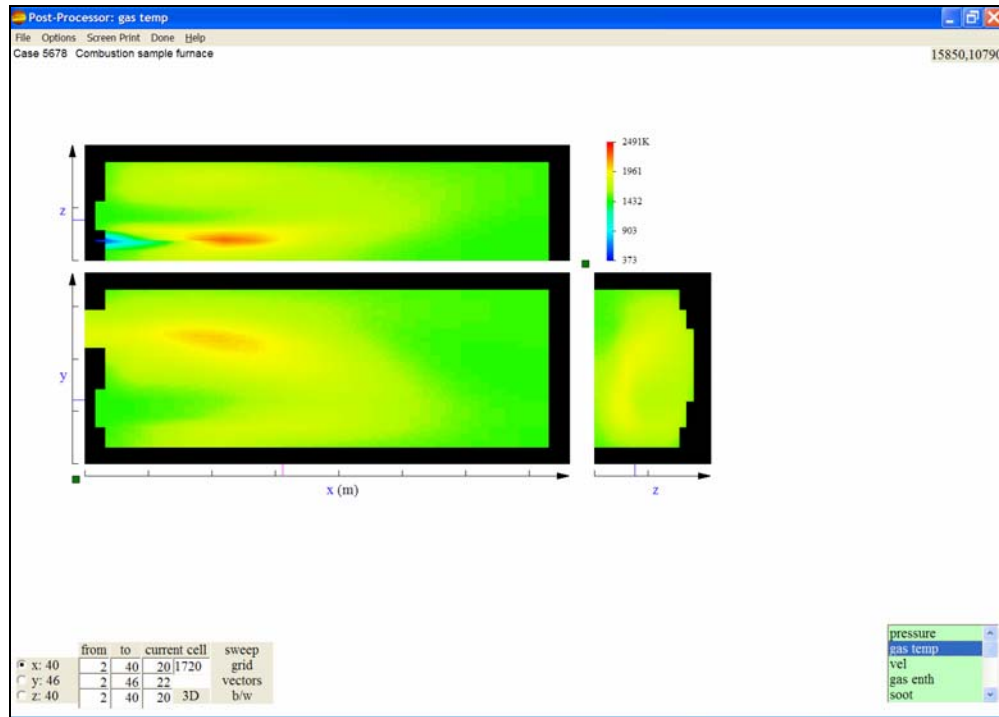

Figure 7. Sample Plot View

- A scrollable list of output field variables is shown in the lower right corner of the screen. The first variable in the output list is displayed on the plot.
 - There is no need for the simulation status box so it is not displayed.
 - The grid controls in column 6 of the grid control block have changed.
15. Look at the simulation output.
- Click on the variable list item that you want displayed.
 - You can use the same viewing techniques that were described in step 6 above.
 - Click on the **Options** → **Plot** submenu items or on the controls in column 6 of the grid control block to change how the plot is displayed. The **sweep** and **B/W** controls have already been explained. When you click the **grid** control, the grid lines will be superimposed on the plot. When you click on **vectors**, the velocity vectors will be superimposed on the plot. The grid and vectors will be removed when you click on an output variable.
 - You may also start up the RunPlot program after the simulation has been stopped by clicking on the **Options** → **Activate RunPlot** menu.

16. Leave the Post-Processor environment.

- Leave the Post-Processor environment of the GUI by clicking the *Done* menu item to return to the main menu.

17. Exit GFM by clicking the *Exit* menu item.

Example 2: Create a New Case from a Previous Case,

Simulate Same Furnace with Different Run Parameters

Start GFM.

In Pre-Processor environment:

1. Select flow domain and open a previous case.
 - From the main menu click on *Pre-Processor* to display the submenu showing the domain choices.
 - Click on the *Combustion Space* or the *Melter* menu item to choose the flow domain you want to work in. This action displays a blank screen with the Pre-Processor menu bar.
 - Click on the *File → Open Case* menu item to display a “Select Existing Case to Open” dialog window listing the cases already in the appropriate directory, “combustion” or “melt”.
 - Select the case filename and click *Open* to open the case and display the figure view. If the case grid had been enhanced then the case will come up in the protect-grid-edits mode.
2. Save copy of previous case as a new case.
 - Click on the *File → Save Case As (Setup Only)* menu item to display another “Create New Case” dialog window.
 - Enter a new case number and click *OK*. The files in the old case are copied and the new files are named with the new case number.
3. Adjust simulation run parameters.
 - Click on the *Properties → Simulation Parameters* menu item to display parameter list boxes.
 - Update the parameters as desired.
 - Click on the *File → Save Case* menu item.
4. Return to the main menu by clicking the *Done* menu item and proceed with simulation and post processing as was done for a new case from scratch.

Exit GFM.

Appendix 4

GFM 4.0 Files

This document provides a brief description of files that are created in the process of setting up and simulating a case in GFM. The number of files that are created in the course of setting up and running a simulation has been greatly increased in GFM Version 4. However, file management was also automated in GFM 4, changing the focus of user work in the user interface and control program to “cases.” The user interface and control program builds and manages all the files needed to run a simulation without the user having to open, change, or save individual files when working in the GFM application. Instead, cases are opened, changed, saved, copied, or chosen for simulation or post processing, and all of the file operations needed to accomplish user initiated actions or maintain furnace geometry and operating data are handled automatically by the control program. Except for files that contain progress data that can be plotted and summary data, the user does not need to know the details of file content or how files are used. The files can be divided into several types that are indicated by the file extension. In general there are files that define the model of a glass furnace including geometry, material properties, and other parameters of a case, files that contain intermediate results and boundary conditions that are used by one of the GFM components, and output files that contain simulation progress data and results that are of primary interest to the user.

Probably the most useful tables are Tables 2 and 5 that list the files that contain simulation progress and monitoring data that can be plotted with the `RunPlot` program. The “*nnnn*” in file names in tables stands for a four digit case number. In plots generated by `RunPlot`, the x axis is an iteration count from one of the solver loops. In many cases it is the iteration count from the CFD flow solver for either the gas in the combustion space or the molten glass in the melt space. However, in some cases it may be the iteration count associated with the particular data plotted, such as radiation solver iterations in a plot of residuals from the equation governing radiosities in the wall and boundary radiation exchange computation. The y axis quantities are in *SI* units: temperatures are in degrees Kelvin (K), energy transfer rates are in watts (W), etc. The title bar and legend indicate what quantities are plotted, such as mean temperature in the melt. In cases where the dependent variable spans many orders of magnitude, the y axis is usually a *log* scale, and this fact is also noted in the title bar.

Because the user interface and control program creates, copies, and deletes files on a case basis and automatically updates and moves control and boundary condition

files between the melt and combustion space directory case folders for more involved simulations such as coupled cycling between combustion and melt, the user normally does not need knowledge of the files used or their contents. However, a list of these files is provided here for those interested. The files related to building a model, saving its definition, and controlling a simulation for a case are listed in Tables 3 and 6 with a brief explanation of content.

Result files summarizing results, giving run termination status and used in post processing are listed in Tables 4 and 7. The **summary** files contain information that appears at the beginning and end of the **info** files in the relevant case folders in the melt and combustion space directories.

Table 1 defines the categories of files based on file extension. Table 8 lists miscellaneous files not saved in the case folders.

Table 1: GFM File Types

<i>File Extension</i>	<i>Type</i>	<i>Explanation</i>
d	binary	simulation state data for restart or other data
dat	text	data defining grid geometry, simulation setup parameters, and boundary conditions
out	text	main output of 3D field variable values for post processing
plt	text	simulation progress data that can be plotted with RunPlot
pre	text	geometry, parameter, and material property data used by the pre-processor
txt	text	various result summary, case definition, and message files for a case

Table 2: Combustion Space Simulation Monitoring Data Files

<i>File Name</i>	<i>Explanation</i>
conv_wallnnnnc.plt	equation residuals for radiation wall exchange
convgnnnnc.plt	mean and maximum mass residuals
fchgnnnnc.plt	relative change in mean melt surface heat flux from one cycle to the next
gresidnnnnc.plt	residuals from gas energy, pressure, and momentum equations
gresidpnnnnc.plt	pre-solve residuals from gas energy, pressure, and momentum equations
gresid_xtrannc.plt	residuals from major species and turbulence equations
gresid_xtrapnnnnc.plt	pre-solve residuals from major species and turbulence equations
Infonnnnc.plt	evolution of energy sources, sinks, and transfers
mresidnnnnc.plt	residuals from minor and radiating species equations
rad_detailnnnnc.plt	radiation details from volume
soot_calnnnnc.plt	evolution of values during soot calibration
Tavennnnc.plt	evolution of mean temperatures over the volume, exits, and walls

Table 3: Combustion Space Simulation Setup and State Files

<i>File Name</i>	<i>Explanation</i>
casennnnc.txt	case title, description, and user case notes
gdnnnnc.dat	combustion space grid definition and cell types
gdnnnnc.pre	preprocessor data including case geometry, inlet flow rates, material properties, case conditions and simulation control parameters
itnnnncm.dat	heat flux distribution at melt surface transferred to melt simulation in coupled simulations
itnnnncnt.dat	temperature distribution at melt surface transferred from melt simulation in coupled simulations
itnnnncT_relax.dat	relaxed temperature distribution at melt surface used to damp large oscillations in coupling conditions
rgnnnnc.d	restart data for gas CFD computation
rrnnnnc.d	restart data for gas and wall radiation heat transfer computation
rsnnnnc.d	restart data for minor and radiating species computation
sbcnnnnc.dat	setup and boundary condition data

Table 4: Combustion Space Result Files

<i>File Name</i>	<i>Explanation</i>
rtnnnnc.out	field variable values over the domain used by post processor to display and visualize results
runend.txt	message indicating normal or error termination of run
summarynnnnc.txt	summary of results of run including energy and mass balances, in and out flows, energy transfer rates and losses, and other information
twallnnnnc.txt	grid cell array showing wall temperatures

Table 5: Melt Space Simulation Monitoring Data Files

<i>File Name</i>	<i>Explanation</i>
convgnnnnm.plt	mean and maximum mass residuals
gresidnnnnm.plt	residuals from glass melt energy, pressure, and momentum equations
gresidpnnnnm.plt	pre-solve residuals from glass melt energy, pressure, and momentum equations
Infonnnnm.plt	evolution of energy sources, sinks, and transfers
Tavennnnm.plt	evolution of mean temperatures over the volume and exits
Tchgnnnnm.plt	relative change in mean melt surface temperature from one cycle to the next

Table 6: Melt Space Simulation Setup and State Files

<i>File Name</i>	<i>Explanation</i>
casennnnm.txt	case title, description, and user case notes
gdnnnnc.dat	combustion space grid definition and cell types used to interpolate coupling conditions at melt surface between combustion and melt grids
gdnnnnm.dat	melt grid definition and cell types
gdnnnnm.pre	preprocessor data including case geometry, inlet flow rates, material properties, case conditions and simulation control parameters
itnnnnm.dat	heat flux distribution at melt surface transferred to melt simulation in coupled simulations
itnnnnm_adjflux.dat	surface heat flux scaled to meet batch and melt heat rate needed
itnnnnm_relax.dat	relaxed surface heat flux distribution used to damp large oscillations in coupling conditions
itnnnnt.dat	temperature distribution at melt surface
rgnnnnm.d	restart data for melt CFD computation
sbcnnnnm.dat	melt setup and boundary condition data

Table 7: Melt Space Result Files

<i>File Name</i>	<i>Explanation</i>
<i>rtnnnm.out</i>	field variable values over the domain used by post processor to display and visualize results
<i>runend.txt</i>	message indicating normal or error termination of run
<i>summarynnnm.txt</i>	summary of results of run including energy and mass balances, in and out flows, energy transfer rates and losses, and other information

Table 8: Miscellaneous Files

<i>File Name</i>	<i>Explanation</i>
<i>cycleInfo.txt</i>	temporary file, cycle number from GUI to CFD program
<i>gfm.dat</i>	temporary file, status from CFD program to GUI
<i>gui-update.txt</i>	temporary file, request from GUI to change update status in CFD program
<i>kinetic.d</i>	constant kinetic data supplied by GFM program
<i>relaxfactorc.txt</i>	combustion relaxation factors used to control changes to computed variables
<i>relaxfactorm.txt</i>	melt relaxation factors used to control changes to computed variables
<i>runs.dat</i>	specification of case to run
<i>runstop.dat</i>	request from GUI to end CFD program

Appendix 5

GFM 4.0 Automatic Cycling Guide

1 Introduction to Cycling

Automatic simulation cycling between combustion and melt spaces is a process implemented in the graphical user interface (GUI) and control program of the *Glass Furnace Model* (GFM) that allows a coupled solution of conditions in the combustion and melt domains to be achieved with minimal user intervention. The cycling includes exchange of the common boundary information at the melt surface. This feature allows a large number of cycles to be carried out without the user having to copy melt surface boundary condition files between directories or having to manually start up the computation again in the domain that comes next in a long sequence of cycles. Essentially all of this can be accomplished in an unattended run in the domain cycling mode of operation. With this feature the intervals for exchange of the common melt surface boundary information can be shortened (because no human intervention is required) providing more frequent exchange of information between spaces and therefore tighter coupling. Automatic domain cycling can be set for both regular and regenerative furnace simulations. This document describes the domain cycling feature and how to set up and initiate automatic domain cycling runs in the graphical user interface and control program.

Four new menu choices have been added to the main **Simulation** menu to start up automatic domain cycling runs. These new **Simulation** sub-items are:

- Cycle Domains (Comb First)

- Cycle Domains (Melt First)

- Cycle Regenerative (Comb First)

- Cycle Regenerative (Melt First)

Selecting one of these menu items pops up a **Provide Cycle Information** dialog box, shown in Figure 1, asking for the number of cycles to run, and allowing the user to change the maximum number of computation iterations to perform for the major stages of the cycle. In addition, if the option to scale the heat flux into the melt is on, the number of cycles to continue scaling may be specified. This mode of running provides a way to approach an expected solution before turning scaling off. If fuel

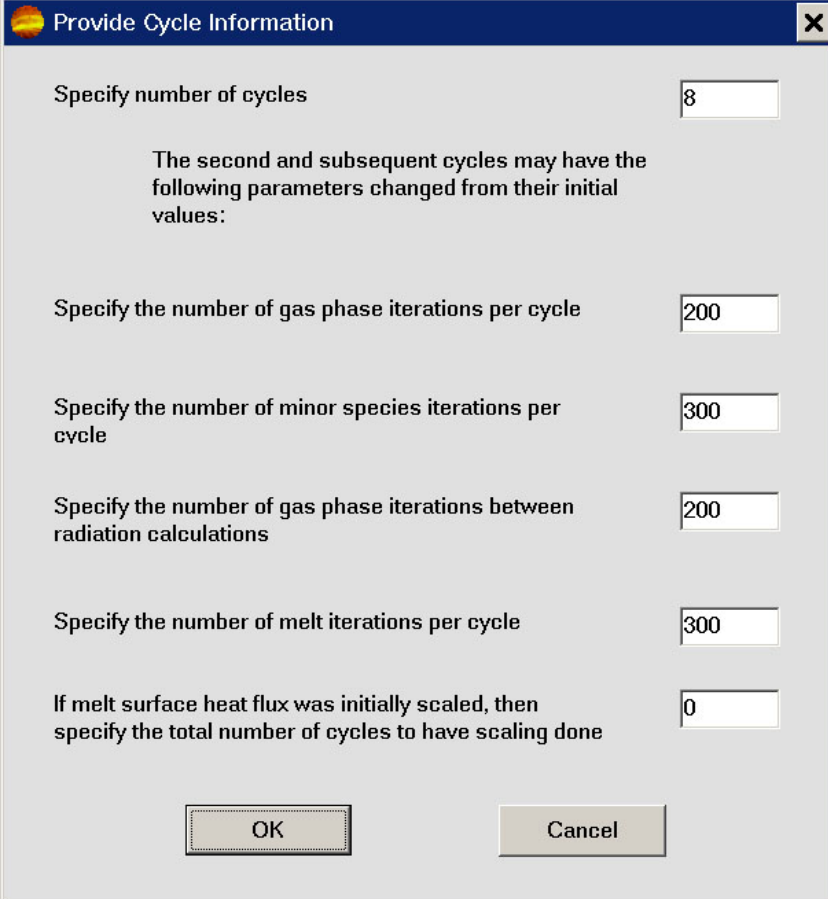

The dialog box titled "Provide Cycle Information" contains the following fields and text:

- Specify number of cycles: 8
- The second and subsequent cycles may have the following parameters changed from their initial values:
- Specify the number of gas phase iterations per cycle: 200
- Specify the number of minor species iterations per cycle: 300
- Specify the number of gas phase iterations between radiation calculations: 200
- Specify the number of melt iterations per cycle: 300
- If melt surface heat flux was initially scaled, then specify the total number of cycles to have scaling done: 0

Buttons: OK, Cancel

Figure 1: Provide Cycle Information Dialog Box

flow in the combustion space has been set to provide sufficient energy to the melt to reach a known glass outlet temperature, scaling ensures that required energy enters the melt during early cycles when temperatures have not yet approached a stable mean in both spaces. Note that if the option to scale the heat flux into the melt is off, then the number of cycles to continue scaling entered in the dialog box is ignored.

After *OK* is entered for the *Provide Cycle Information* dialog box, the *Select Existing Case to Simulate* dialog box appears and allows the user to navigate through the file system to the file folder of the case to simulate. If the melt space simulation is to be run first, the simulation must be started from the case folder in the melt directory. If the combustion space simulation is to be run first, the simulation must be started from the case folder in the combustion directory. The case must be set up for automatic cycling in both the melt and combustion space case definitions as described in the following sections.

Coupling between the combustion and melt spaces is accomplished by passing the heat flux, both radiation and convection, to the melt surface calculated in the combustion domain to the melt domain and then passing the surface temperature calcu-

lated in the melt domain to the combustion domain automatically. The user interface and control program copies the appropriate melt surface temperature and heat flux distribution files back and forth between the melt and combustion subdirectories. The melt and combustion spaces are coupled through the energy equation boundary conditions at the melt surface. In the combustion space, the surface temperature computed in the melt code is the boundary condition. In the melt space, the surface heat flux distribution computed in the combustion space code is the boundary condition. Tight coupling between the two spaces requires that these conditions be swapped frequently. Automatic cycling allows this swapping to be done many times in an unattended overnight or over-weekend run. The iteration limits set in the **Provide Cycle Information** dialog box control the swap points and swap frequency.

2 Cycle Domains Algorithm

The algorithm for automatic cycling of domains with the combustion space run first is as follows:

1. Clicking on the **Simulation→Cycle Domains (Comb First)** menu item will begin a regular combustion simulation for a four digit case number “*nnnn*” determined by the `casennnn` folder chosen.
2. When the combustion simulation stops, a melt simulation is automatically started for the same case number using the heat flux data from the combustion domain.
3. When the melt simulation stops, one cycle is complete.
4. The combustion simulation is automatically restarted using the surface temperature distribution data from the melt domain and it runs until it completes (a user specified number of iterations).
5. The melt simulation is automatically restarted after the combustion simulation completes.
6. The whole cycling process (repeating steps 4 and 5) stops when a specified number of cycles has been completed.

The active domain, combustion or melt, and the cycle number are shown in a light blue box in the lower right corner of the main GFM window when in simulation mode. The display switches between the combustion and melt space depending on which is active.

The mean relative change in coupling conditions, heat flux distribution and temperature distribution at the melt surface can be checked to determine if a coupled simulation is sufficiently converged. If not, another set of cycles can be run. The mean relative change in coupling conditions can also be displayed as a dynamically updated plot on-screen (Refer to the RunPlot documentation), and the cycling can

be terminated when the mean relative change is sufficiently small.

The algorithm for automatic cycling of domains with the melt space first is the same as that for doing the combustion space first, enumerated above, except that the melt computation is run first. Both spaces can be sensitive to the boundary conditions at the surface that they share, and consequently convergence of the coupled solution may depend on how close the initial guess or starting point is to a converged solution. Because energy requirements for the melt space can be estimated from batch feed rates and material properties based on a reasonably close estimate of the melt exit temperature, a melt space computation done first with scaling turned on may give a surface temperature distribution that is a good estimate for a first combustion space computation, if the average melt temperature has begun to approach its asymptotic value.

If cycling with the melt computation done first does not converge, cycling with the combustion space run first with a uniform surface temperature based on a good estimate of expected mean surface temperature may succeed. The melt surface temperature is the primary known surface temperature boundary used in the radiation enclosure exchange calculation. Wall surfaces use a known heat flux boundary condition in this computation based on a heat balance at the wall that includes incoming radiation from the emitting media. Consequently, wall temperatures tend to approach temperatures that are slightly above the melt surface temperature (just enough higher to re-radiate the additional amount arriving from the flame minus the amount lost through the walls).

3 Setup for Cycle Domains

Various strategies can be used to prepare for automatic cycling:

- A. The simplest strategy is to set up initial conditions the same as the subsequent cycle conditions. However, this strategy may require a very large number of cycles to be run before convergence is achieved.
- B. If desired, both or either one of the domains may be simulated for a while independently and later restarted for the cycling process. Before doing an automatic cycling run this strategy could be used to verify that iterating in each domain was possible or it could be used to establish a basic flow field in each domain and approach a stable mean temperature. This strategy could reduce the number of cycles required for convergence, but manual intervention is needed before the automatic cycling is started.
- C. A combination strategy is to set up the initial cycle conditions to iterate long enough to establish a flow field and approach a stable mean temperature. The number of iterations in the subsequent cycles is greatly reduced to provide frequent swapping of surface boundary condition data. This strategy could also

reduce the number of cycles required for convergence. Strategy C is described here.

Setting up a combustion first automatic cycling of domains simulation consists of the following:

1. Create a combustion case and a melt case with the same case number. The bottom dimensions of the combustion domain should match the top dimensions of the main melt surface component (excluding refiner area) in the melt domain.
 - During the initial case definition, set these necessary combustion parameters:
 - While in the preprocessor combustion domain, click on the **Properties**→**Simulation Parameters** menu item to display 4 lists of parameters in green boxes.
 - Click on the second item in the first (leftmost) green box until parameter *new start* is displayed and then set the *initial iterations* (fourth line in the rightmost green box) to a number that will allow an initial flow field to be established, 600 appears to be reasonable. (For strategy B the parameter will be *restart*. For strategy A and B the *initial iterations* would likely be from 100 to 200.)
 - Set the combustion parameters to indicate that radiation will be calculated. Click on the bottom item in the leftmost green box until parameter *calc radiation* is displayed.
 - The radiation *interval* (displayed in the bottom item of the third green box) must not be greater than the number of gas phase *iterations* (displayed in the third item in the first green box). *interval* is the number of combustion space fluid dynamic iterations between radiation computations that include absorbing and emitting media and the wall and melt surface enclosure radiation exchange computation. Immediately after a radiation computation an updated set of melt surface heat flux distribution values is available.
 - For automatic cycling, the *iterations* parameter should be set equal to *interval*. This will cause the updated melt surface heat flux set to be transferred to the melt computation as soon as it is available. The default for these values is 200 in the combustion space. More experience is needed to determine what value is optimum. Any feedback on user experience would be appreciated.
 - (For a combustion space only run the *iterations* parameter should be about 6 to 8 times the *interval* value.)
 - Set the melt surface temperature type (in the first item of the fourth green box). If the melt domain has already been simulated, then the surface type can be set to indicate that the melt simulation has calculated the temperature (*melt surf: calculated*). Otherwise indicate that the temperature is specified (*melt surf: specified*) and set the initial

surface temperature in the next item of the fourth green box. After the first cycle, the control program will set parameters so that the melt surface temperature in the combustion space will be the distribution calculated from the melt domain.

- During the initial case definition, set these necessary melt parameters:
 - While in the preprocessor melt domain, click on the **Properties**→**Simulation Parameters** menu item to display 3 lists of parameters in green boxes.
 - Click on the second item in the first (leftmost) green box until parameter *new start* is displayed. (For strategy B the parameter will be *restart*).
 - The melt simulation will be done after a combustion simulation so the heat flux will be determined by the combustion calculation. Set the melt heat flux parameter to indicate either *heat flux: fixed* or *heat flux: scaled* with the next line showing *calc. in combustion*. Click on the second item in the third green box until the desired option is displayed.
 - The *heat flux: scaled* parameter indicates that the combustion calculated surface heat flux will be scaled to meet heat requirements needed to reach a user specified liquid glass exit temperature. This heat requirement calculation for scaling includes heat needed for solids heating, solids melting, liquid glass heating, melt tank wall losses, and the heat added by electric boosters.
 - In automatic cycling mode the *iterations* parameter in the melt is the number of global solver iterations that will be performed before switching back to the combustion space. Because the melt is essentially a large reservoir it tends to respond rather slowly to changing conditions, such as an updated heat flux from the combustion space. Several thousand total iterations in the melt may be required to reach a converged steady state melt solution. Therefore, the *iterations* could initially be set to a large number, 3000 appears to be reasonable. (For strategy A and B, setting *iterations* in the melt to a value between 200 and 400 appears reasonable.)
2. After saving both the combustion and melt cases in the preprocessor, go back to the main menu and click on the **Simulation**→**Cycle Domains (Comb First)**, to bring up the **Provide Cycle Information** dialog box with default values. Enter the number of cycles to run in this set of automatic cycles if the desired number is different from the default. The GFM control program keeps track of the number of cycles in the current set of cycles. If an additional set of cycles is activated, the simulations will continue where they had left off previously, but the cycle count itself will begin anew. In other words, the GFM control program does not keep track of a global cycle count; each set of cycles starts with cycle number 1.

3. Whereas the parameters specified during the initial case definition apply to the first cycle in the set of cycles to be done, the remaining information provided on the **Provide Cycle Information** dialog box apply to the second and subsequent cycles in the set. Changing both the number of gas phase iterations per cycle and the number of gas phase iterations between radiation calculations to 100 may speed up convergence by swapping heat flux in shorter intervals than the default 200, however, the radiation computation takes a long time, and therefore, doing it before the flow field has begun to stabilize in the new cycle may lead to longer convergence times. Some experimentation and watching convergence rates of the mean temperatures and equation residuals with the **RunPlot** program may be necessary to optimize iteration count settings.
4. Note that the last entry in the dialog box is ignored when scaling has not be specified for the melt surface heat flux. Also, the “total number of cycles” mentioned for this entry applies to the number of cycles for the current cycle set.
5. After clicking the *OK* button on the **Provide Cycle Information** dialog box, select the case to cycle from the **Select Existing Case to Simulate** dialog box and click the *Simulate* button to start the cycling.
6. Note that the user may stop the cycling run gracefully during any cycle by clicking on the **Stop Run** menu item and indicating that the run should stop after the current cycle has completed.

Setup for a melt first automatic cycling of domains is similar to the setup for combustion first, except for the melt surface conditions. In the melt domain set the *heat flux: fixed* or *heat flux: scaled* parameter with the next line showing *uniform value* and provide that value on the following line. In the combustion domain set the first line in the rightmost green box to be *melt surf: calculated*. Also, the menu item to begin automatic cycling will be **Simulation→Cycle Domains (Melt First)**.

4 Alternatives After Running an Automatic Cycle Set

The status of a case after automatic cycling is different from the status of a case after running a regular simulation. When the user saves a case in the preprocessor, an input file to the CFD code is created from the user’s definition of the case. After running a regular simulation that input file is still in sync with the case definition. However, the GFM control program modifies the CFD code input files during automatic cycling, but does not modify the case definition. Therefore, determining what to do after an automatic cycling run must account for the differences in case status.

After running an automatic cycle set and evaluating the results, the user may choose to proceed in a variety of ways. The primary options are described below.

- **Start Over:** If the run results look bad, then the user may decide to start over from scratch with different parameter and control settings. The best way to start over is to get into the **Pre-Processor→Combustion Space or Glass Melter→File** menu and click on **Delete Case Results**. Then the user can open up the case in the preprocessor, change the case definition as needed, and proceed from that point with a new start.
- **Continue cycling with another cycle set:** If a review of results indicates that more cycles are needed to reach a stable converged solution, another automatic cycling run can be started and it will pick up where it left off as long as no changes are made to the case via the user interface that result in the user saving a changed case. To simply run another cycle set from the state where the last one finished, the user should go back to the main menu, click on the same **Simulation→Cycle Domains ...** that was used before, and enter the appropriate information in the **Provide Cycle Information** dialog box.
- **Continue cycling with changed parameters:** If an automatic cycling run is to be restarted with changes to operating parameters via the user interface that require saving the case, then the following run parameters must also be set to restart an automatic cycling run. These steps bring the case definition files into sync with the run setup files passed to the combustion and melt CFD codes during cycling. (Note that automatic cycling cannot be restarted if either of the grids are modified.)

For the combustion space case, with the case open:

1. Display the green simulation parameters boxes by clicking on the **Properties→Simulation Parameters** menu item.
2. If the first parameter under *Parameters* in the first green box indicates *new start*, click it so that it indicates *restart*.
3. Set the surface temperature type (in the first item of the fourth green box) to indicate that the melt simulation has calculated the temperature (*melt surf: calculated*).

For the melt space case, with the case open:

1. Display the green simulation parameters boxes by clicking on the **Properties→Simulation Parameters** menu item.
2. If the first parameter under *Parameters* in the first green box indicates *new start*, click it so that it indicates *restart*.
3. Set the *iterations* to the value used for number of melt iterations set in the **Provide Cycle Information** dialog box used for subsequent cycles from the previous cycle set (default 300). This parameter should be set larger if an operating condition has been changed that would significantly change the mean temperature of the melt.

4. Set the melt heat flux parameter to indicate either *heat flux: fixed* or *heat flux: scaled* with the next line showing *calc. in combustion*.
- **Start a new case cycling with changed parameters from the state of a converged case:** If the run results look good and converged, then the user may decide to use this case as a base for other cases, for example to do parametric studies. Get into the Pre-Processor→Combustion Space or Glass Melter→File menu and open the case. Then return to the same menu and click on Save Case As (Full case) to make a copy of the case using a new case number. Make operational parameter changes as desired in the new case and proceed as indicated in the previous bullet item above.
 - **Stop:** If the run results look good and converged, then the user may decide to do nothing more with the case.

5 Regenerative Furnace Cycle Algorithm

- The regenerative furnace cycle algorithm builds upon the cycle domain algorithm.
- Domain cycling for regenerative furnaces is started via a Simulation→Cycle Regenerative item from the main menu.
- For a regenerative furnace simulation, two combustion space domain simulations are done, one for each of the burner and exhaust firing patterns. The setup for these simulations of alternate firing patterns is described in the next section.
- Both combustion domain simulations pass a melt surface heat flux distribution to the melt domain simulation and the two sets of data are averaged together for use. The melt domain will pass surface temperature data to both of the combustion domain simulations for the next cycle.

This algorithm for simulation of regenerative furnaces assumes that the melt acts as a large heat reservoir and responds slowly to the alternating changes in firing pattern of the regenerative furnace. The asymptotic state of the melt for a single firing pattern may be simulated by setting up a case with the desired firing pattern and running it as a non-regenerative furnace case.

6 Setup for Regenerative Furnace Domain Cycling

- Construct burners and exhausts as usual for one of the two firing patterns in the combustion space grid. Set other parameters as needed for this firing pattern. Save the setup using a case number, N , where the next consecutive case number $N + 1$ is not in use.
- The case number for the 2^{nd} burner firing pattern must be $N + 1$. A starting point for creating the $N + 1$ case with the alternate firing pattern may be created by using the **File**→**Save Case As** menu item to save combustion case N as case $N + 1$.
- Modify the furnace figure for case $N + 1$ so that the exhausts become burners and burners become exhausts to create the second, alternative firing configuration for the regenerative furnace, or do whatever is needed to define the 2^{nd} burner firing configuration.

For example, for a furnace with one burner, $B1$, and one exhaust, $E1$:

1. Add exhaust $E2$ and set its position to be centered over burner $B1$.
 2. Add burner $B2$ and set its position to be centered over exhaust $E1$.
 3. Delete $B1$
 4. Delete $E1$
- Make adjustments to other flow parameters as needed to match the furnace operating conditions in the alternate burner firing mode.
 - Set up the melt space as usual using case number N . Do not set up a melt space for case number $N + 1$.
 - When all is ready, start an automatic cycling simulation by selecting menu item **Simulation**→**Cycle Regenerative**.

Appendix 6

GFM 4.0 RunPlot User's Guide

Introduction

RunPlot is a simple line plotting utility that draws to the screen. *RunPlot* can be used to monitor the progress or evolution of various scalar variables during iteration while running a CFD code. *RunPlot* can also be used to review the evolution of these variables after the computation has completed. In the Glass Furnace Model software, plot data files are generated for a variety of quantities of interest such as mass residuals, other partial differential equation (PDE) residuals, mean temperature, and the various global energy quantities, such as the energy loss rate through walls, \dot{q}_{wall} .

Quantities that Can Be Monitored

Both the combustion space and melt space computations output some files that are updated after each iteration in the computation with new values of variables that can be monitored with *RunPlot*. These files are listed with the quantities that they contain in Table 1. Files with a *c* preceding the file extension are located in the combustion `case` folders usually in the `combustion` subdirectory where *GFM* is installed. Files with an *m* preceding the file extension are located in the melt `case` folders usually in the `melt` subdirectory.

File Structure for *RunPlot*

RunPlot creates screen plots from data arranged in columns, referred to as the data table, in a selected file. Information on the file structure is provided here so that the user can add notes to a file without causing *RunPlot* to fail when attempting to plot data from the file and so that other files can be generated if desired that can be plotted on screen with the *RunPlot* utility. *RunPlot* is a simple utility program and is not intended for sophisticated uses or the generation of presentation plots; it is intended to provide a quick visualization via on screen line plotting of the trends for variables of interest, or a quick way to later review the progress of a computation after it is completed. A toggle to change the screen plot background from black to white is provided so that screen captures can be made that will print on a standard

Table 1: GFM Files in *RunPlot* Format

File	Description of Quantities
<code>conv_wallnnnnc.plt</code>	Equation residuals for radiation wall exchange
<code>convgnnnnc.plt</code>	Max and mean log mass residual, combustion space
<code>convgnnnnm.plt</code>	Max and mean log mass residual in melt
<code>fchgnnnnc.plt</code>	Relative change in mean melt surface heat flux from one cycle to the next
<code>gresidnnnnc.plt</code>	Pressure, momentum, and enthalpy log PDE residuals in combustion space
<code>gresidnnnnm.plt</code>	Pressure and momentum log PDE residuals from glass melt energy
<code>gresidpnnnnc.plt</code>	Pre-solve pressure, momentum, and enthalpy log PDE residuals in combustion space
<code>gresidpnnnnm.plt</code>	Pre-solve pressure and momentum log PDE residuals from glass melt energy
<code>gresid_xtrannnnc.plt</code>	Major species and k-epsilon log PDE residuals in combustion space
<code>gresid_xtrapnnnnc.plt</code>	Pre-solve major species and k-epsilon log PDE residuals in combustion space
<code>Infonnnnnc.plt</code>	Energy sources, transfers, losses, combustion space
<code>Infonnnnm.plt</code>	Energy sources, transfers, losses, melt space
<code>mresidnnnnc.plt</code>	Minor species log PDE residual, combustion space
<code>rad_detailnnnnc.plt</code>	Radiation details from volume, combustion space
<code>soot_calnnnnc.plt</code>	Evolution of values during soot calibration, combustion space
<code>Tavennnnc.plt</code>	Volume mean temperature, combustion space
<code>Tavennnm.plt</code>	Mass mean temperature in melt space
<code>Tchgnnnm.plt</code>	Relative change in mean melt surface temperature from one cycle to the next

printer without using excessive ink or toner. However, loading the data table into a spread sheet to generate plots with legends, labels, notes, etc. is the expected way to prepare data plots from the files for presentation. *RunPlot* does generate a window with a legend with plot data label text color corresponding to the on screen plot line color to provide a means to easily identify lines in a plot of many quantities.

To provide flexibility, commentary may appear before, within, and after the data table (see Figure 2). A line beginning with a “#_” where the “_” denotes at least one white space character (tab or blank) and containing the tag *plotdata* anywhere on the line identifies the beginning of the data table. The line with the *plotdata* tag must appear immediately before, except for blank lines, the line containing the column headings of the data. The coupling of these two lines allows the program to identify the data column heading line and generate legend window text from the headings. Within the data table, lines containing only white space (blank lines) are ignored.

In addition, any lines beginning with “#” as the first non-blank text are ignored. An end of file or a line beginning with non-numeric text other than “#” as the first non-blank text is considered to identify the end of the data table.

The first line in the file is taken to be a title line. Text on this line up to a “_/” not including an initial “#” is the *title*. The *title* is included in the window caption. If word “log” occurs anywhere on the title line, before or after a “_/” *title* termination, the y-data will be plotted on a log scale. The title line may be followed by other commentary or data up to the line with the *plotdata* tag identifying the start of the data table. A good practice in generating plot files from other software is simply to begin all lines that are not part of the data table with a “#” character, indicating a comment line.

The *title* normally indicates the type of data plotted. It also normally includes the file name of the data plotted, to allow identification of the source of the data when multiple plots are displayed on screen. Plotted lines are associated with the data column via the plotted line color. This correspondence is given in Table 2. Correspondence between line colors and data column headings printed as text in the legend window is also established via text and line color.

The format of the data table columns is as follows. The first column of numbers is assumed to contain the abscissa (x-axis) values. Normally these values are the integer iteration count corresponding to the ordinate (y-axis) values in the remaining columns. The data columns are separated by white space, and as many different variables as there are data columns will be plotted. The numeric data in columns can be in any number format (integer, floating point, exponential notation). If there are more data columns than plot colors listed in Table 2, the program will cycle back through the colors to plot additional columns of data.

Table 2: Plot Line Colors for Data Columns

Data Column	Color	
	Black Background	White Background
1	None—x-values	None—x-values
2	Red	Red
3	Light Blue	Blue
4	Green	Dark Green
5	Yellow	Brown
6	Plum	Purple
7	Orange	Orange
8	White	Black

Operation and Control of *RunPlot*

On startup *RunPlot* displays an *Open Plot Data* dialog box for selecting the file with data to be plotted. If the file contains a valid data table, plots will be drawn in the plot window. The plot window caption is composed of the application name, the title,

if present, and the file name. Resizing the plot window in the horizontal direction will change the number of tic marks and tic labels on the x-axis. In general the program tries to put as many tic marks with labels on the x-axis as space will allow while preserving reasonable inter-label spacing. With this scheme, the tic spacing may not be uniform. The number of tics and labels on the y-axis is five by default, but may be increased or decreased via user input.

In addition to resizing the window, user control over a few items of the plot display is provided by actions initiated by user key press input. Keys and the associated actions are listed in Table 3. Right clicking the mouse within the plot window will

Table 3: Keyboard Input and Right Click Mouse *RunPlot* Actions

Key	Description of Action
-	Decrease font size
+ or =	Increase font size
b	Toggle between light and dark backgrounds
f	Open file dialog box (to get new file to plot)
l	Toggle show legend window
y	Decrease the number of y-axis tics and labels
Y	Increase the number of y-axis tics and labels

display a menu listing the actions in this table providing a means to execute them via the mouse. When the log of the data is plotted, all integers in the set of the log of the range of the data are used to label the y-axis. Therefore, when log of the y-data is plotted, the number of y-tics cannot be changed.

Multiple instances of *RunPlot* can be run to display and monitor variables from different files in different windows at the same time.

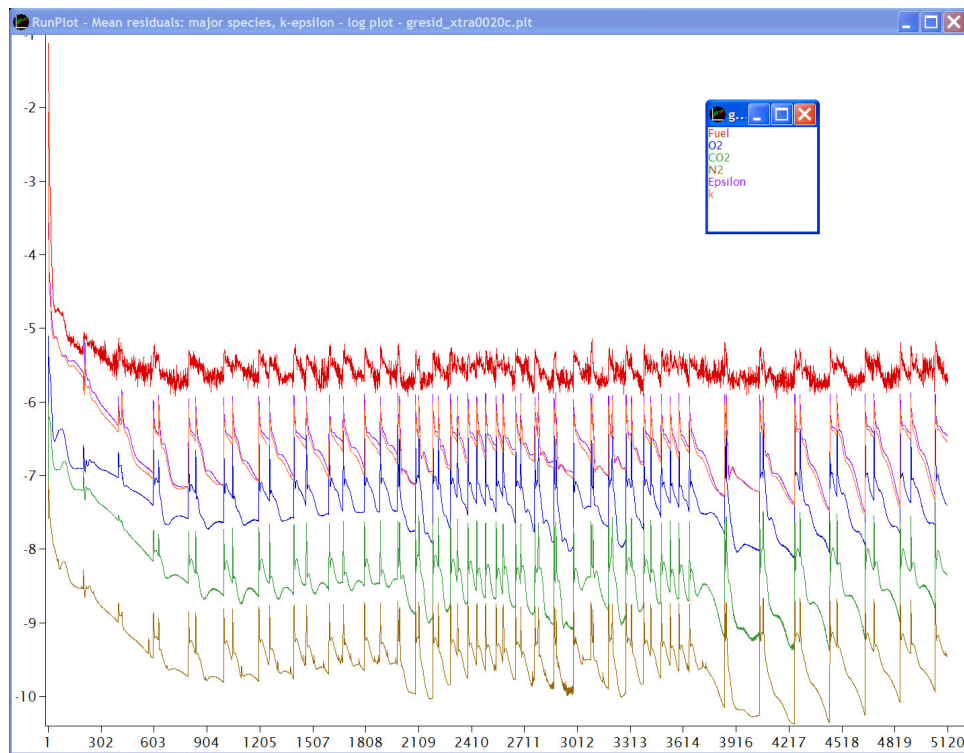

Figure 1: Plot with log scale of mean residuals for major species and k-epsilon equations.

```

# Average and max log mass residual // title comment

Summary or other data that won't be read as plot data:
    298 K      - Ambient Temperature
    101325 Pa - Pressure

# PlotData - tag that identifies start of data table
#   iter  average mass residual      max mass residual

    1  0.6577189205781596E-03  0.3483270774362953E+00
    2  0.8023438418717733E-02  0.1205137081186856E+01
    3  0.1412642398188446E-01  0.1702145623881210E+01
    4  0.1864279324049479E-01  0.1198321797782262E+01
    5  0.2295087775480696E-01  0.1590848875742073E+01

    6  0.2388359323445141E-01  0.1965758786872932E+01
    7  0.2005357974720045E-01  0.1699897379301678E+01

# Note in the middle of a data table

    8  0.1978368055630363E-01  0.1344666918635310E+01
    9  0.1773269006233475E-01  0.1374926758949880E+01

Notes after end of data table.
More data that won't be plotted:

    10 0.1518379910490138E-01  0.1198976665759578E+01
    11 0.1393631901720333E-01  0.1554607806217381E+01

```

Figure 2: Example *RunPlot* data file.

Appendix 7

International Commission on Glass Technical Committee 21 Round Robin Test 4 and Test 4a Specification

Technical Committee 21 (TC21) of the International Commission on Glass (ICG) provided round robin test 4 and 4a (RRT4 and RRT4a) specifications for modeling glass melting processes. The definition given here is from the April 25, 2004 committee meeting in Yalos, Athens. The main parts of the two ICG TC21 test specifications have been merged and are shown here:

Melt Specifications

- Kinematic viscosity;

$$\begin{aligned}
 \nu_{\text{Batch}} &= 0.4 \text{ m}^2/\text{sec} && \text{for } 30 \text{ }^\circ\text{C} < T < 1000 \text{ }^\circ\text{C} \\
 \nu_{\text{Batch}} &= f(T), \text{ a linear function} && \text{for } 1000 \text{ }^\circ\text{C} < T < 1200 \text{ }^\circ\text{C} \\
 \nu_{\text{Batch}}(1200 \text{ }^\circ\text{C}) &= \nu_{\text{Glass}}(1200 \text{ }^\circ\text{C}) && \text{for } T = 1200 \text{ }^\circ\text{C} \\
 \nu_{\text{Batch}} &= \nu_{\text{Glass}} && \text{for } T > 1200 \text{ }^\circ\text{C} \text{ and} \\
 \text{Dynamic viscosity of glass } \log \eta &= -1.58 + 4332/(T-248), && \\
 &&& \text{with } T \text{ in } ^\circ\text{C} \text{ and } \eta \text{ in dPa}\cdot\text{sec}
 \end{aligned}$$

- Density of glass $\rho_{\text{Glass}} = 2520.8 - 0.138T \text{ kg/m}^3 \text{ T(K)}$

- Density; $\rho_{\text{Batch}} = 1400 \text{ kg/m}^3 \quad 300 \text{ K} < T < 823 \text{ K}$ and

$$\rho_{\text{Batch}} = -328.538 + 2.10029T \quad 823 \text{ K} < T < 1273 \text{ K}$$

$$\rho_{\text{Batch}} = \rho_{\text{Glass}} = 2520.8 - 0.138T \text{ kg/m}^3 \text{ for } T > 1273 \text{ K}$$

- Batch reactions take place between $550 \text{ }^\circ\text{C} < T < 1000 \text{ }^\circ\text{C}$

- Batch inlet $T = 30 \text{ }^\circ\text{C}$

- Batch exit $T = 1200 \text{ }^\circ\text{C}$

- Batch exit start temperature = $1200 \text{ }^\circ\text{C}$

- Batch existance temperature interval : $30 \text{ }^\circ\text{C} < T < 1400 \text{ }^\circ\text{C}$

- Heat of reaction = 750 kJ/kg of glass

- Ambient $T = 30 \text{ }^\circ\text{C}$

- Emissivity of batch surface, $\epsilon_{\text{Batch}} = 0.9$

- Emissivity of glass surface, $\epsilon_{\text{Glass}} = 0.9$

- Emissivity of all walls, $\epsilon_{\text{Refractory}} = 0.8$

- Thermal conductivity of glass $\lambda_g = 30 \text{ W/m}\cdot\text{K}$

- Thermal conductivity of batch $\lambda_b = \exp\{-3.01943 - (2569.15/(T - 1873.14))\}$;

for $300 \text{ K} < T < 1473 \text{ K}$, where T is in K and λ_b is in $\text{W}/(\text{m}\cdot\text{K})$.

- Thermal conductivity of batch $\lambda_b = \lambda_g = 30 \text{ W}/\text{m}\cdot\text{K}$ (same as glass) for $T > 1473 \text{ K}$

Other conditions

- Free grid
- Batch thickness: 10 cm at the start;
- Charging temperature of batch: 30°C ;
- Batch is assumed to be fed from the back of the furnace (full width) and in the horizontal direction.
- Evaporation of gases from the batch blanket will not be considered.
- Reference $T = 1600 \text{ K}$
- Heat Capacity of glass $C_p = 1300 \text{ J}/\text{kg}\cdot\text{K}$
- Heat Capacity of batch
 $C_p = 1000 \text{ J}/\text{kg}\cdot\text{K}$ at 30°C and $C_p = 1300 \text{ J}/\text{kg}\cdot\text{K}$ at 1200°C and changes linearly for $30^\circ\text{C} < T < 1200^\circ\text{C}$ and
 $C_p = 1300 \text{ J}/\text{kg}\cdot\text{K}$ (same as glass) for $T > 1200^\circ\text{C}$.
- Expansion coefficient $\beta = 6 \times 10^{-5} \text{ 1}/\text{K}$
- Basin walls are 30 cm thick. For exterior heat transfer coefficients, it has been concluded to use the previously determined value of $10 \text{ W}/\text{m}^2\cdot\text{K}$ for convection and radiation for both the combustion space and for glass tank. Moreover, since the furnace is small, wall losses will be determined for 3-dimensional walls.
- The pull rates are;

Case a : 25 metric tons per day	Case b : 40 metric tons per day
Batch length 3.0 m	Batch length 4.2 m
- The superstructure temperature profiles:

Case a; $x=0\text{m}: 1300^\circ\text{C}$, $x=3\text{m}: 1400^\circ\text{C}$, $x=4\text{m}: 1600^\circ\text{C}$, $x=7\text{m}: 1400^\circ\text{C}$
Case b; $x=0\text{m}: 1300^\circ\text{C}$, $x=4.2\text{m}: 1400^\circ\text{C}$, $x=5\text{m}: 1600^\circ\text{C}$, $x=7\text{m}: 1400^\circ\text{C}$
- In cases where the modeling approaches of members do not comply with the restrictions specified in this definition they could study the problem with their own combined batch models and explain how the conditions are different from the original definition.
- Some of the items for the operational parameters might not be justified under the boundary conditions yet the principle is to use the same conditions as far as possible.

Furnace Geometry

Top View

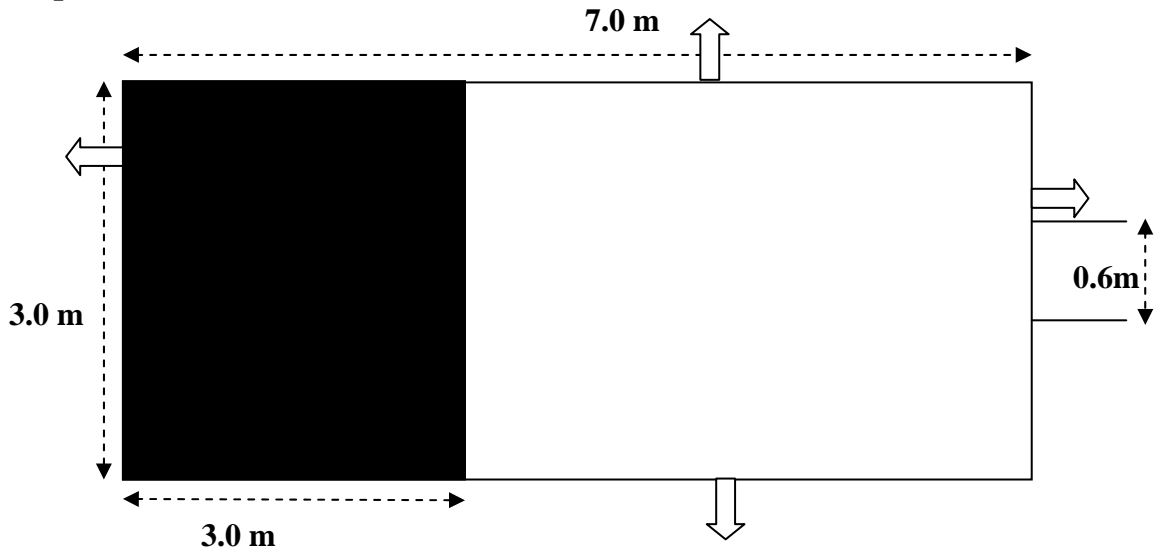

Side View

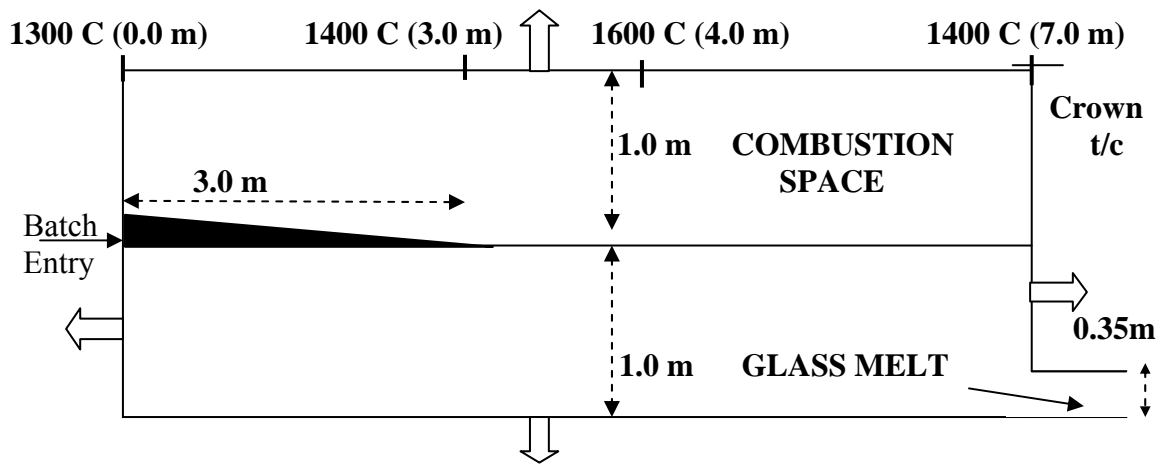

Combustion Specifications

Furnace length : 7 m

Furnace width : 3 m
 Crown height from glass surface: 1.5 m

Natural gas calorific value: 5.0×10^7 J/kg
 Natural gas is assumed to be 100% CH₄ and enters furnace at 373K

Total gas consumption: 0.039762 kg/sec for 40t/d
 0.029858 kg/sec for 25t/d

Combustion air input temperature: 1473 K

Combustion air input : 0.71750 kg/sec for 40t/d
 0.53812 kg/sec for 25t/d

Excess air: 5 %

Ambient T: 303 K

Side wall refractories wall thickness 30 cm.
 Crown refractories wall thickness 30 cm .
 Emissivity of refractories: 0.8
 Emissivity of batch blanket: 0.9

Firing reversal ratio is to be taken into account with symmetrical averages.

Buoyancy effect will not be considered. But the case might be studied with the buoyancy effect additionally.

Combustion Space and Port Geometry

Lateral view

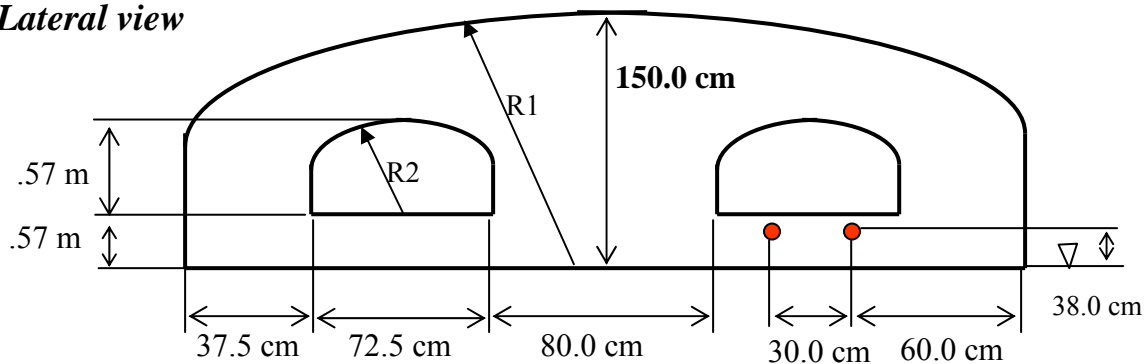

R_1 , radius for crown; 435 cm
 R_2 , radius for port crown; 100 cm

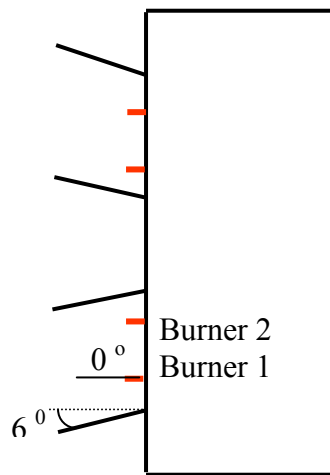
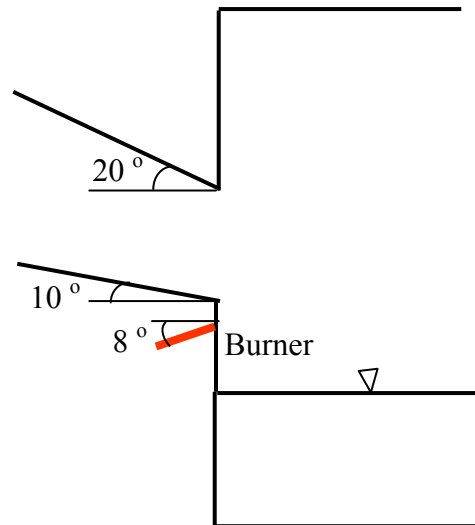
Top view for ports and burners***Side view for ports and burners***

Number of burners per port: 2

Burner with a vertical angle of 8° and a horizontal angle of 0° .

- Burner 2x2 cm with 71 m/sec gas velocity at burner tip at 25 t/d (which is close to the 80 m/sec recommended during the meeting) and
- Burner 2.2x2.2 cm with 78 m/sec gas velocity at burner tip at 40 t/d.

Boundary Conditions

- Temperature on inside of crown is specified in above pictures. Radiation models will be used to calculate heat transfer from crown to batch and glass surface.
- No temperature gradients to the sides.
- At the beginning of the furnace, 0.0 m, the temperature is 1300 C. Then temperature increases with a linear gradient up to 1400 C at 3.0 meter. After that the temperature increases further with a linear gradient to 1600 C at location of 4.0 m.
- In the last 3.0 m, the temperature decreases with a linear gradient down to 1400 C at the end of the furnace, 7.0 m.
- Parabolic output flow in throat exit
- Participants can use own batch models, use heat sink with value of 750 kJ/kg required melting energy for raw materials and heat dissociation of gases (no cullet).

Results and output

- Minimum residence time at throat entrance
- Mean temperature at throat entrance
- Location of mechanical spring
- Values of velocity vectors in center plane at $x= 2.0$ meter and $x= 4.0$ meter and at depths of 0.2 m and 0.7 m.
- Velocity and temperature plots of central longitudinal plane
- Velocity and temperature profile plots along the depth at $x= 2.0$ meter and $x= 4.0$ meter
- Temperature profile along the center line of the glass surface and bottom along the length of furnace (about 0.05 m above bottom and below glass surface if necessary)
- Total wall losses in W
- Heat balance will be shown
- Final position of the batch will be indicated.

- Temperature values of crown along the length of the furnace at the centerline; at $x = 0,1, 2,3,4$ and 7 m.
- Side and top view for velocity and temperature contours of combustion space at a cross section through the burners.
- Heat flux values for batch-glass and batch-combustion space interfaces.



Energy Systems Division

Argonne National Laboratory
9700 South Cass Avenue, Bldg. 362
Argonne, IL 60439-4815

www.anl.gov



UChicago ►
Argonne_{LLC}

A U.S. Department of Energy laboratory
managed by UChicago Argonne, LLC