

WRI-06-R018

TOPICAL REPORT

NEW SOIL VOC SAMPLERS: EN CORE[®] AND ACCU CORE[™] SAMPLING/STORAGE DEVICES FOR VOC ANALYSIS

Work Performed Under Cooperative Agreement
DE-FC26-98FT40323 Task 5

June 2006

By

Susan S. Sorini

John F. Schabron

Joseph F. Rovani, Jr.

For

En Novative Technologies, Inc.

Green Bay, Wisconsin

and

U.S. Department of Energy

Office of Fossil Energy

National Energy Technology Laboratory

Morgantown, West Virginia

By

Western Research Institute

Laramie, Wyoming

ACKNOWLEDGMENTS

Funding for this study was provided by the U.S. Department of Energy, National Energy Technology Laboratory, under Cooperative Agreement DE-FC26-98FT40323 and En Novative Technologies, Inc., Green Bay, Wisconsin.

DISCLAIMER

This report was prepared as an account of work sponsored by an agency of the United States Government. Neither the United States Government nor any agency thereof, nor any of their employees makes any warranty, express or implied, or assumes any legal liability or responsibility for the accuracy, completeness, or usefulness of any information, apparatus, product, or process disclosed or represents that its use would not infringe on privately owned rights. Reference herein to any specific commercial product, process, or service by trade name, trademark, manufacturer, or otherwise does not necessarily constitute or imply endorsement, recommendation, or favoring by the United States Government or any agency thereof. The views and opinions of authors expressed herein do not necessarily state or reflect those of the United States Government or any agency thereof.

ABSTRACT

Soil sampling and storage practices for volatile organic analysis must be designed to minimize loss of volatile organic compounds (VOCs) from samples. The En Core[®] sampler is designed to collect and store soil samples in a manner that minimizes loss of contaminants due to volatilization and/or biodegradation. An ASTM International (ASTM) standard practice, D 6418, Standard Practice for Using the Disposable En Core Sampler for Sampling and Storing Soil for Volatile Organic Analysis, describes use of the En Core sampler to collect and store a soil sample of approximately 5 grams or 25 grams for volatile organic analysis and specifies sample storage in the En Core sampler at 4 ± 2 °C for up to 48 hours; -7 to -21 °C for up to 14 days; or 4 ± 2 °C for up to 48 hours followed by storage at -7 to -21 °C for up to five days. This report discusses activities performed during the past year to promote and continue acceptance of the En Core samplers based on their performance to store soil samples for VOC analysis.

The En Core sampler is designed to collect soil samples for VOC analysis at the soil surface. To date, a sampling tool for collecting and storing subsurface soil samples for VOC analysis is not available. Development of a subsurface VOC sampling/storage device was initiated in 1999. This device, which is called the Accu Core[™] sampler, is designed so that a soil sample can be collected below the surface using a dual-tube penetrometer and transported to the laboratory for analysis in the same container. Laboratory testing of the current Accu Core design shows that the device holds low-level concentrations of VOCs in soil samples during 48-hour storage at 4 ± 2 °C and that the device is ready for field evaluation to generate additional performance data. This report discusses a field validation exercise that was attempted in Pennsylvania in 2004 and activities being performed to plan and conduct a field validation study in 2006. A draft ASTM practice describing use of the Accu Core sampler is being prepared. An update on the status of the ASTM practice is given in this report.

TABLE OF CONTENTS

	<u>Page</u>
LIST OF FIGURES	v
EXECUTIVE SUMMARY	vi
INTRODUCTION	1
En Core [®] Sampler	1
Accu Core [™] Sampler	2
Current Work	2
OBJECTIVES	3
RESULTS AND DISCUSSION	4
Facilitating National Acceptance of the En Core Sampler	4
Field Evaluation of the Accu Core Sampler	6
Development of a Standard Practice for Using Subsurface Samplers for Sampling and Storing Soil for Volatile Organic Analysis.....	7
CONCLUSIONS.....	7
REFERENCES	8

LIST OF FIGURES

<u>Figure</u>		<u>Page</u>
1.	Components of the En Core Sampler.....	9
2.	Reusable Attachments to the En Core Sampler	10
3.	Accu Core Sampler Being Sealed.....	11

EXECUTIVE SUMMARY

Soil sampling and storage practices for volatile organic analysis must be designed to minimize loss of volatile organic compounds (VOCs) from samples. The En Core[®] sampler is designed to collect and store soil samples in a manner that minimizes loss of contaminants due to volatilization and/or biodegradation. An ASTM International (ASTM) standard practice, D 6418, Standard Practice for Using the Disposable En Core Sampler for Sampling and Storing Soil for Volatile Organic Analysis, describes use of the En Core sampler to collect and store a soil sample of approximately 5 grams or 25 grams for volatile organic analysis and specifies sample storage in the En Core sampler at 4 ± 2 °C for up to 48 hours; -7 to -21 °C for up to 14 days; or 4 ± 2 °C for up to 48 hours followed by storage at -7 to -21 °C for up to five days.

This report discusses activities performed during the past year to promote and continue acceptance of the En Core samplers based on their performance to store soil samples for VOC analysis. As part of this, a procedure for evaluating the performance of hand-operated coring devices to store soil samples for VOC analysis was written and balloted within ASTM Subcommittee D 34.01 on Sampling, Monitoring, and Characterization. The procedure that was balloted was used to evaluate the performance of the En Core samplers and generate data for inclusion in D 6418. The procedure was balloted as an appendix to ASTM D 4547, Standard Guide for Sampling Waste and Soils for Volatile Organic Compounds, at the direction of ASTM Task Group D 34.01.03 on Sampling Equipment. The task group wants to provide a protocol to be used for testing the performance of hand-operated coring devices to store soil samples for VOC analysis to determine if criteria given in D 4547 are met. Other activities that were performed include authoring publications and presenting information on sampling soil for VOC analysis.

The En Core sampler is designed to collect soil samples for VOC analysis at the soil surface. To date, a sampling tool for collecting and storing subsurface soil samples for VOC analysis is not available. Development of a subsurface VOC sampling/storage device was initiated in 1999. This device, which is called the Accu Core[™] sampler, is designed so that a soil sample can be collected below the surface using a dual-tube penetrometer and transported to the laboratory for analysis in the same container. Laboratory testing of the current Accu Core design shows that the device holds low-level concentrations of VOCs in soil samples during 48-hour storage at 4 ± 2 °C and that the device is ready for field evaluation to generate additional performance data. This report discusses a field validation exercise that was attempted in Pennsylvania in 2004 and activities being performed to plan and conduct a field validation study in 2006. A draft ASTM practice describing use of the Accu Core sampler is being prepared. An update on the status of the ASTM practice is given in this report.

INTRODUCTION

A major problem in sampling soil for volatile organic analysis is preservation of sample integrity during storage and shipment of soil samples to the laboratory. Soil sampling and storage practices for volatile organic analysis must be designed to minimize loss of volatile organic compounds (VOCs) due to volatilization and/or biodegradation. Laboratory data can grossly underestimate the actual VOC concentrations in a soil if great attention is not paid to sampling and handling techniques (Turrieff and Klopp 1995).

En Core[®] Sampler

The En Core[®] sampling/storage device provides a simple means for sampling soil and holding a soil sample during shipment to the laboratory for VOC analysis (Vitale et al. 1999). This device has three components: (1) the coring body/storage chamber, which is volumetrically designed to collect and store either a soil sample of approximately 5 grams or 25 grams, (2) an O-ring sealed plunger for non-disruptive extrusion of the sample into an appropriate container for analysis or preservation, and (3) a slide-on cap having an O-ring seal and locking arm mechanism. A diagram of the En Core sampling/storage device is shown in Figure 1. The seals of the device are provided by three Viton[™] O-rings (Figure 1). The coring body/storage chamber, plunger, and cap of the En Core sampler are constructed of a glass-filled inert composite polymer, polyphthalamide (RTP), making the device chemically compatible with soil matrices and contaminants. The En Core sampler is disposable. It is certified as clean when received from the manufacturer and is not to be reused. The En Core sampler has two reusable stainless steel attachments. These are a T-handle, which is used to push the sampler into the soil for sample collection; and an extrusion tool, which attaches to the plunger for extrusion of the sample from the coring body/storage chamber. These are shown in Figure 2. Each En Core sampler is supplied with a protective moisture-proof bag for shipment to the laboratory.

Western Research Institute (WRI) developed an ASTM International (ASTM) standard practice for using the En Core device. This practice is D 6418, Standard Practice for Using the Disposable En Core Sampler for Sampling and Storing Soil for Volatile Organic Analysis (ASTM 2005a). A number of studies have been conducted to update the practice since the original standard was approved in 1999. The current version of D 6418 includes an appendix showing data on the performance of the En Core sampler to store soils spiked with low-level concentrations of VOCs under the conditions specified in the practice (4 ± 2 °C for up to 48 hours; -7 to -21 °C for up to 14 days; and 4 ± 2 °C for up to 48 hours followed by storage at -7 to -21 °C for up to five days).

Accu Core™ Sampler

The En Core sampler is designed to collect soil samples for VOC analysis at the soil surface. To date, a sampling tool for collecting and storing subsurface soil samples for VOC analysis is not available. Development of a subsurface VOC sampling/storage device was initiated in 1999. This device, which is called the Accu Core™ sampler, is designed so that a soil sample can be collected below the surface using a dual-tube penetrometer and transported to the laboratory for analysis in the same container. Laboratory testing of the current Accu Core design shows that the device holds low-level concentrations of VOCs in soil samples during 48-hour storage at 4 ± 2 °C and that the device is ready for field evaluation to generate additional performance data. WRI initiated development of an ASTM standard practice for using the subsurface sampler. Work on development of this standard continues.

Soil from the subsurface is collected in a two-foot long Accu Core sample collection liner that fits inside a dual-tube penetrometer. The collection liner consists of alternating 3-inch clear plastic sections and 1-inch stainless steel sections in a clear plastic shrink-wrap. The 3-inch clear plastic sections have a one-half inch access hole in the middle of the section for easy access for headspace screening, such as with a photo-ionization detector (PID). With this design, the integrity of the remaining soil core will not be violated during screening. The sections may be held in the shrink wrap until the appropriate sampling interval is determined, at which point, the corresponding stainless steel section is removed and sealed with a patented interlocking capping system to maintain volatile integrity during transportation to the laboratory. Figure 3 shows an Accu Core stainless steel section being sealed with the interlocking caps.

Current Work

This report discusses activities performed during the past year to promote and continue acceptance of the En Core samplers based on their performance to store soil samples for VOC analysis. As part of this, a procedure for evaluating the performance of hand-operated coring devices to store soil samples for VOC analysis was written and balloted within ASTM Subcommittee D 34.01 on Sampling, Monitoring, and Characterization. The procedure that was balloted was used to evaluate the performance of the En Core samplers and generate data for inclusion in D 6418. The procedure was balloted as an appendix to ASTM D 4547, Standard Guide for Sampling Waste and Soils for Volatile Organic Compounds (ASTM 2005b), at the direction of ASTM Task Group D 34.01.03 on Sampling Equipment. The task group wants to provide a protocol to be used for testing the performance of hand-operated coring devices to store soil samples for VOC analysis to determine if criteria given in D 4547 are met. Other activities that were performed include authoring publications and presenting information on sampling soil for VOC analysis.

This report also discusses a field validation exercise that was attempted in Pennsylvania in 2004 to generate performance data for using the Accu Core sampler in the field. Unfortunately, when subsurface samples from the field site were obtained and screened, it was apparent that the site did not contain VOC contamination, as originally reported, and the Accu Core field validation activity could not be performed. Currently, activities are being performed to plan a field validation study that will be conducted in 2006. In addition, progress has been made on preparation of the draft ASTM practice, which describes use of the Accu Core sampler. An update on the status of the ASTM practice is given in this report.

OBJECTIVES

The overall objectives of this task are to facilitate national acceptance of the En Core device for sampling and storing soil for VOC analysis and to validate the performance of the Accu Core subsurface sampler for sampling and storing soil for VOC analysis. The activities that were performed over the last 12 months to help achieve these objectives are described below.

- An article titled “En Core[®] Sampler Performance for Storage of Soil Samples at -7 to -21 °C,” was written and published in *Remediation Weekly*, a science and news journal (Sorini et al. 2004).
- An article titled “EPA 5035A: Is an Empty VOA Vial and Freezing Really the Best Option?” was co-authored with a hydro-geologist from the Washington State Department of Ecology and published on the www.Environmental-Expert.com website.
- The keynote presentation titled “Soil Sampling for EPA Method 5035A Analysis” was given at the Washington State Department of Ecology training course on soil VOC sampling for EPA Method 5035A analysis (Northwest Environmental Education Council 2004).
- An article titled “Collecting Soil VOC Samples by EPA 5035A: Here’s Three Things You Should Know” was co-authored with a hydro-geologist from the Washington State Department of Ecology and has been submitted for consideration for publication in *Ground Water Monitoring and Remediation*.
- A procedure for evaluating the performance of hand-operated coring devices to store soil samples for VOC analysis was written and balloted within ASTM Subcommittee D 34.01 on Sampling, Monitoring, and Characterization to provide a protocol to be used for testing the performance of hand-operated coring devices to store soil samples for VOC analysis.

- Field evaluation of the Accu Core sampler at a site in Pennsylvania believed to be contaminated with benzene, toluene, ethyl benzene, and xylene (BTEX compounds) was attempted.
- Activities were performed to initiate planning an Accu Core field validation study that will be conducted in 2006.
- Work continued on preparation of a draft ASTM practice, which describes use of the Accu Core sampler.

RESULTS AND DISCUSSION

Facilitating National Acceptance of the En Core Sampler

An article describing the study that was conducted to evaluate the performance of the En Core sampler to store samples at temperatures ranging from -7 to -21 °C was written for publication in the science and news journal, *Remediation Weekly* (Sorini et al. 2004). Data presented in this article are also included in Appendix X1 of ASTM Practice D 6418 and show how well the En Core sampler performs for storing soil samples under freezing conditions.

An article for publication on the www.Environmental-Expert.com website was co-authored with a hydrogeologist from the Washington State Department of Ecology. This article, which is titled “EPA 5035A: Is an Empty VOA Vial and Freezing Really the Best Option?” is based on data generated in a study previously performed at WRI to evaluate the empty VOA vial method (Sorini et al. 2002). This method involves collecting a soil sample in the field using a disposable modified plastic syringe and immediately extruding the sample into an empty VOA vial for storage during transportation to the laboratory. Results from the study show that VOCs can be lost from the sample during its transfer to the empty VOA vial. Use of the En Core sampler to collect and store a sample for VOC analysis does not require transfer of the sample to another container in the field. As a result, there is less opportunity for VOCs to be lost from the sample. The article was published on the www.Environmental-Expert.com website in June 2005.

A second article titled “Collecting Soil VOC Samples by EPA 5035A: Here’s Three Things You Should Know” was co-authored with the Washington State Department of Ecology hydro-geologist and has been submitted for consideration for publication in *Ground Water Monitoring and Remediation*. This article addresses three issues concerning sampling and analyzing soils for VOCs, including the impact of extruding soil containing VOCs into an empty vial with no preservatives on data quality.

A keynote presentation was given at the October 2004 Washington State Department of Ecology training course titled “Soil VOC Sampling for EPA Method 5035A Analysis” (Northwest Environmental Education Council 2004). The presentation was titled “Soil Sampling for EPA Method 5035A Analysis” and provided information on sampling equipment and sample collection, preservation, storage, and analytical options for soil VOC analysis.

The article on the performance of the En Core sampler to store samples at -7 to -21 °C, the articles discussing concerns about extruding soil samples into empty VOA vials in the field, and the keynote presentation that was given for the Washington State Department of Ecology serve as means of communicating the technical merits of the En Core sampler. These activities, which have as their focus the results of testing performed by WRI, are helping facilitate national acceptance of the En Core device for sampling and storing soil for VOC analysis.

After the En Core sampler was introduced, similar devices were brought forth with the claim that they could be used to store soil for VOC analysis. However, evaluation of the design of the devices showed that they do not meet the specifications given in ASTM D 4547, Standard Guide for Sampling Waste and Soils for Volatile Organic Compounds. D 4547 gives design and performance specifications for small, hand-operated coring devices that are to be used to store samples for VOC analysis. At the March 2005 meeting of ASTM Task Group D34.01.03 on Sampling Equipment, the task group discussed having a recommended procedure for evaluating new devices to determine if they meet the performance criteria given in ASTM D 4547. It is often easy to evaluate the design of a device to determine if it meets the D 4547 specifications; however, it is difficult to evaluate the performance of a device if no standard laboratory testing procedure is available. As a result, the task group recommended that a procedure for evaluating the performance of hand-operated coring devices to store soil samples for VOC analysis be written and balloted within ASTM. The procedure that was prepared is the one that was used to evaluate the performance of the En Core samplers and generate data for inclusion in D 6418.

A proposed revision of ASTM D 4547 to include the procedure for evaluating the performance of hand-operated coring devices to store soil samples for VOC analysis was balloted within ASTM Subcommittee D 34.01 on Sampling, Monitoring, and Characterization. In the balloting, the proposed revision received 26 affirmative votes, 17 abstentions, and two negative votes. The comments received in the balloting have been addressed and were discussed at the October 2005 ASTM Committee D 34 meeting. Changes based on the comments have been made to the procedure. The new proposed revision of D 4547 will be balloted concurrently within the ASTM D 34.01 Subcommittee and ASTM D 34 Main Committee in December 2005.

The presence of this procedure in an appendix of D 4547 will be very significant because it will provide a testing protocol for the ASTM task group, subcommittee, and main committee to use in evaluating new devices to determine if they meet the performance criteria given in D 4547. Because this testing protocol is the same procedure as was used to evaluate the performance of the En Core sampler, there will be assurance that all devices will be evaluated using the same procedure.

Field Evaluation of the Accu Core Sampler

Accu Core sampling/validation field work was attempted at a Pennsylvania site believed to be contaminated with BTEX compounds. The site was to be mapped using a Membrane Interface Probe (MIP) interfaced to a photo-ionization detector (PID)/flame ionization detector (FID) gas chromatograph (GC) to determine where the contaminants of interest were located. This work was to be performed by environmental sampling personnel, who were to provide the information to En Novative Technologies, Inc., the project co-sponsor, and WRI personnel, so sampling locations for the Accu Core validation study could be selected. Samples were to be collected from areas where the contamination appeared to be in the concentration range of 200-800 ppb.

Sections in the sample collection liner were to be configured so that the following samples could be collected from each area and analyzed to compare the different sample handling techniques:

- Two samples for immediate extrusion into methanol and storage on ice during overnight transportation to the laboratory for VOC analysis
- One 5-gram En Core sample for storage on ice during overnight transportation to the laboratory followed by extrusion into methanol for VOC analysis
- One empty VOA vial sample to be collected using a disposable modified plastic syringe and immediately extruded into an empty VOA vial for storage on ice during overnight transportation to the laboratory followed by addition of methanol for VOC analysis
- Two Accu Core samples for storage on ice during overnight transportation to the laboratory followed by extrusion into methanol for VOC analysis

Upon arrival at the field site in Pennsylvania, En Novative Technologies and WRI personnel were informed that no VOC contamination had been found at the site. As a result, the Accu Core sampling/validation field work had to be cancelled.

After field validation of the Accu Core sampler was attempted in Pennsylvania, discussions were initiated with Concurrent Technologies Corporation (CTC) (U.S. DOD National Defense Center for Environmental Excellence) concerning locating a military base site at which field validation testing of the Accu Core could be performed. It was believed that CTC would be helpful in identifying and accessing a site for a validation study. WRI has worked very successfully with CTC on past projects. Currently, activities are being performed to receive approval for performing an Accu Core validation study at North Island Naval Air Base in San Diego, CA, at a location where there is extensive VOC soil contamination. If approval is granted, the study will be conducted in 2006.

Development of a Standard Practice for Using Subsurface Samplers for Sampling and Storing Soil for Volatile Organic Analysis

To help facilitate acceptance of the Accu Core sampler and show performance data for the sampler, development of an ASTM practice that describes use of the device was proposed and approved by ASTM Task Group D 34.01.03 on Sampling Equipment. This practice, which is titled "Standard Practice for Using Subsurface Samplers for Sampling and Storing Soil for Volatile Organic Analysis," is being written with another ASTM member to describe use of two types of subsurface sampling/storage devices. One of the samplers described in the practice is a device that can be used to collect samples down to several meters below ground. The other sampler that is described in the practice is the Accu Core, which can be used to collect samples down to approximately 60 meters below ground. The ASTM practice will include an appendix describing the field validation study and showing data from the study. Sections of the practice that have been completed thus far are: Scope; Referenced Documents; Terminology; Summary of Practice; Significance and Use; Apparatus; Report; and Key Words. The practice should be completed and balloted in ASTM in 2006.

CONCLUSIONS

Activities performed during the past year greatly contributed to promotion and continued acceptance of the En Core samplers. Preparing and balloting a procedure for evaluating the performance of hand-operated coring devices to store soil samples for VOC analysis to become an appendix of D 4547 will lead to assurances that all hand-operated coring devices designed for sample storage will be evaluated using the same laboratory procedure as was used to evaluate the performance of the En Core sampler.

Field validation of the Accu Core sampler has been difficult to perform because of the difficulty in locating a site at which a study can be conducted. However, with help from CTC, it appears that a site may have been located so a study can be performed in 2006. After the field validation study is performed, the ASTM practice describing use of the sampler can be completed and balloted for approval.

REFERENCES

- ASTM International, 2005a, ASTM Practice D 6418-04, Standard Practice for Using the Disposable En Core Sampler for Sampling and Storing Soil for Volatile Organic Analysis. *Annual Book of ASTM Standards*, 11.04, 603 - 616.
- ASTM International, 2005b, ASTM Guide D 4547-03, Standard Guide for Sampling Waste and Soils for Volatile Organic Compounds. *Annual Book of ASTM Standards*, 11.04, 32-42.
- Sorini, S.S., J.F. Schabron, and J.F. Rovani, Jr., 2004, En Core[®] Sampler Performance for Storage of Soil Samples at -7 to -21 °C. *Remediation Weekly*, www.RemediationWeekly.com, Vol. 1, No. 7.
- Sorini, S.S., J.F. Schabron, and J.F. Rovani, Jr., 2002, Evaluation of VOC Loss from Soil Samples. *Contaminated Soil Sediment & Water*, April/May Issue, pp. 39 - 44.
- Northwest Environmental Education Council, 2004, Soil VOC Sampling for EPA Method 5035A Analysis. *Northwest Environmental Training Manual*, Course ID: CHEM-501, Seattle, WA.
- Turriff, D.E., and C. Klopp, 1995, Comparison of Soil Preservation and Analysis Methods for VOC Analytes. *Proceedings of the Field Screening Methods for Hazardous Wastes and Toxic Chemical International Symposium*, Air & Waste Management Association, pp. 1236-1237.
- Vitale, R.J., R. Forman, and L. Dupes, 1999, Comparison of VOC Results Between Methods 5030 and 5035 on a Large Multi-State Hydrocarbon Investigation. *Environmental Testing & Analysis*, January/February, pp. 18, 20, 21, 36.

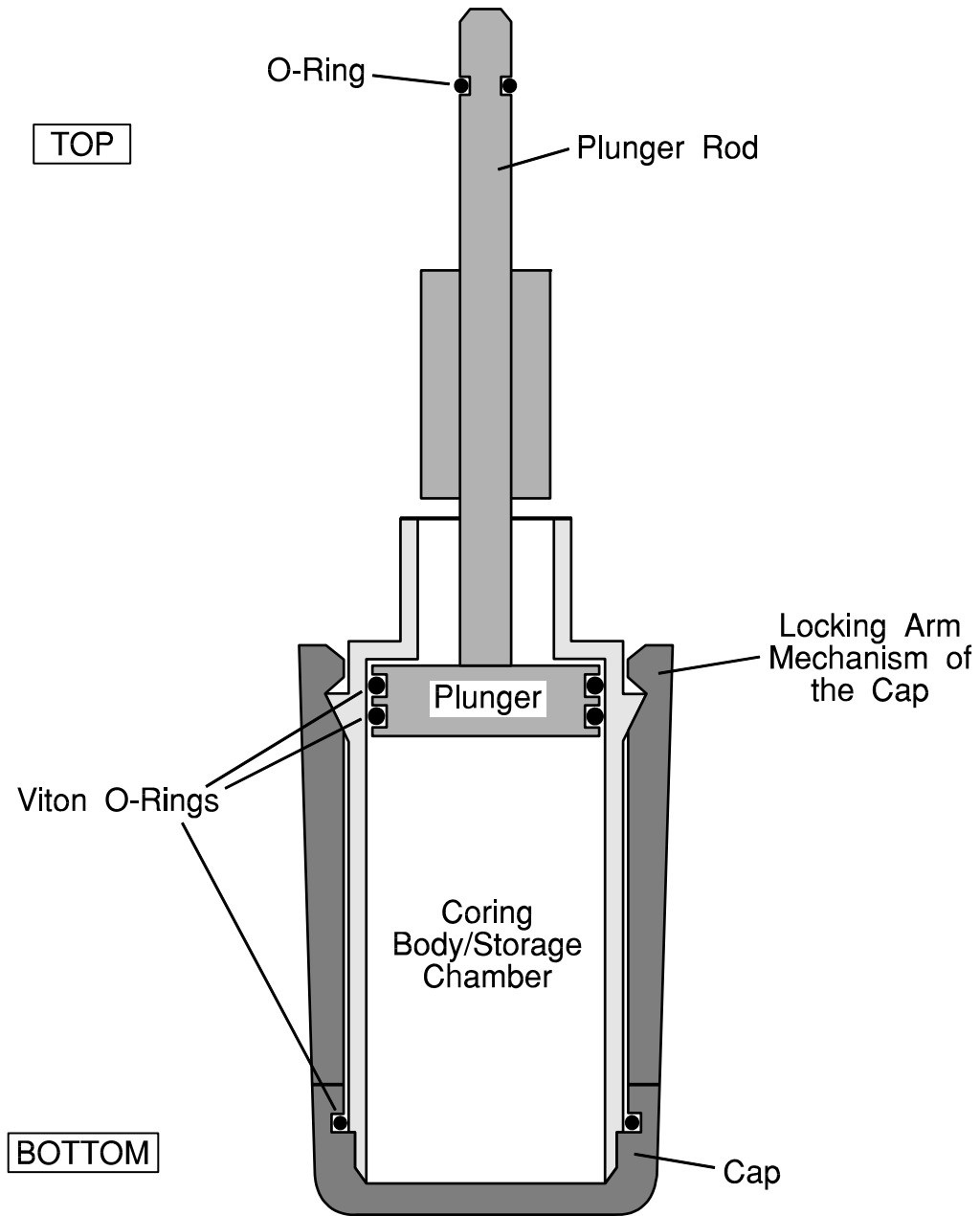
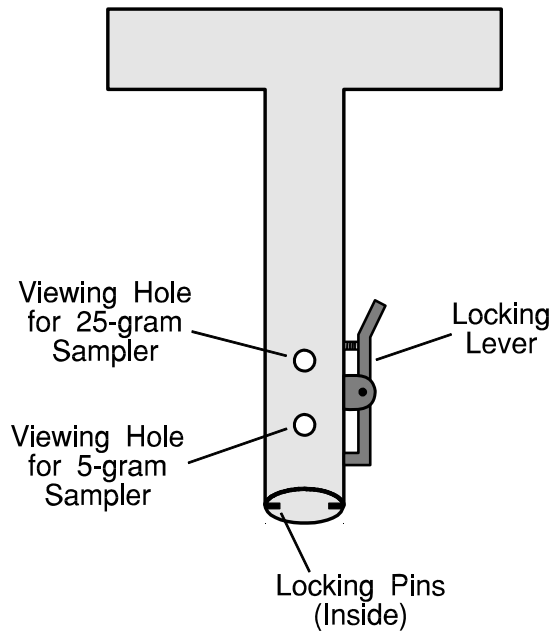

Figure 1. Components of the En Core Sampler

En Core T-Handle



En Core Extrusion Tool

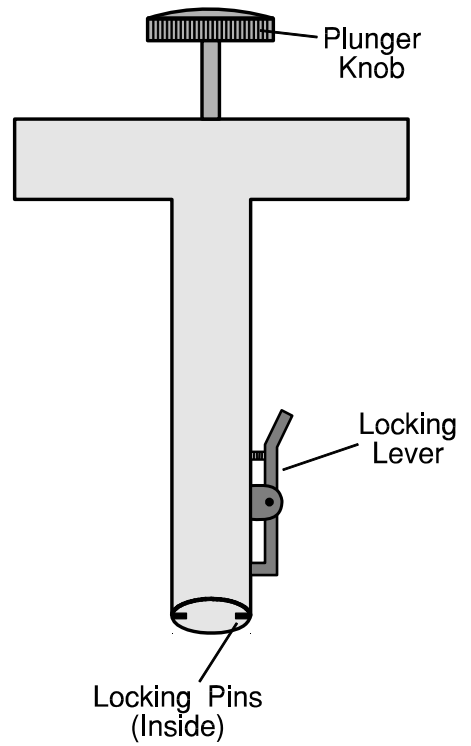

Figure 2. Reusable Attachments to the En Core Sampler



Figure 3. Accu Core Sampler Being Sealed