Princeton Plasma Physics Laboratory

PPPL-4112

PPPL-4112

RF Sources for the ITER Ion Cyclotron Heating and Current Drive System

J. Hosea, C. Brunkhorst, E. Fredd, R.H. Goulding,
N. Greenough, C. Kung, D.A. Rasmussen,
D.W. Swain, and J.R. Wilson

October 2005

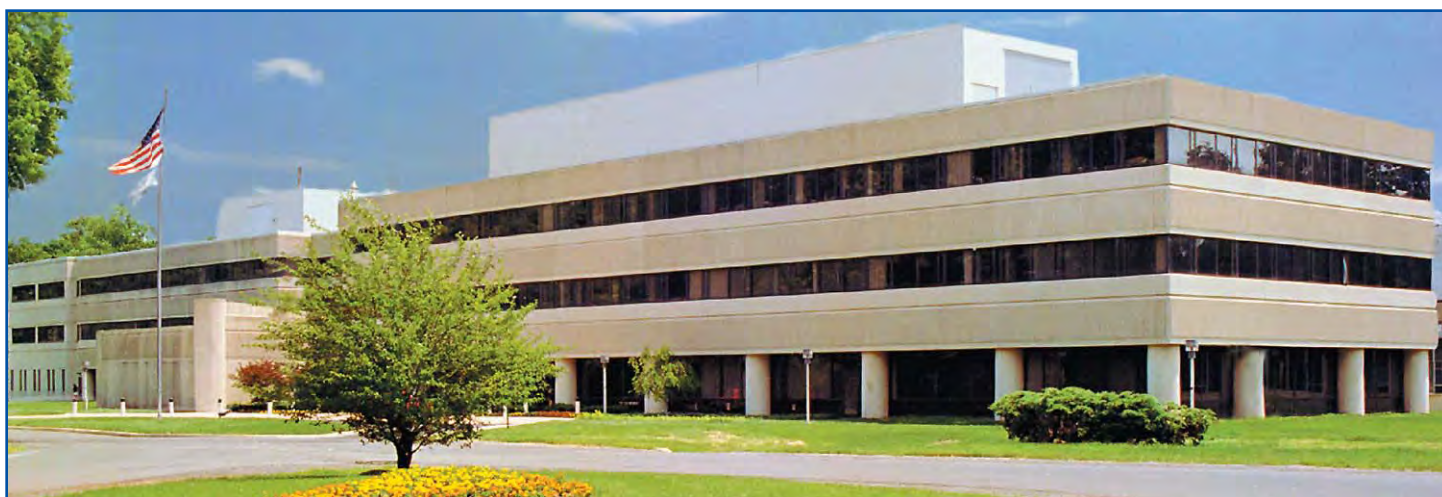

Prepared for the U.S. Department of Energy under Contract DE-AC02-76CH03073.

Princeton Plasma Physics Laboratory

Report Disclaimers

Full Legal Disclaimer

This report was prepared as an account of work sponsored by an agency of the United States Government. Neither the United States Government nor any agency thereof, nor any of their employees, nor any of their contractors, subcontractors or their employees, makes any warranty, express or implied, or assumes any legal liability or responsibility for the accuracy, completeness, or any third party's use or the results of such use of any information, apparatus, product, or process disclosed, or represents that its use would not infringe privately owned rights. Reference herein to any specific commercial product, process, or service by trade name, trademark, manufacturer, or otherwise, does not necessarily constitute or imply its endorsement, recommendation, or favoring by the United States Government or any agency thereof or its contractors or subcontractors. The views and opinions of authors expressed herein do not necessarily state or reflect those of the United States Government or any agency thereof.

Trademark Disclaimer

Reference herein to any specific commercial product, process, or service by trade name, trademark, manufacturer, or otherwise, does not necessarily constitute or imply its endorsement, recommendation, or favoring by the United States Government or any agency thereof or its contractors or subcontractors.

PPPL Report Availability

Princeton Plasma Physics Laboratory

This report is posted on the U.S. Department of Energy's Princeton Plasma Physics Laboratory Publications and Reports web site in Fiscal Year 2006.

The home page for PPPL Reports and Publications is:

http://www.pppl.gov/pub_report/

Office of Scientific and Technical Information (OSTI):

Available electronically at: <http://www.osti.gov/bridge>.

Available for a processing fee to U.S. Department of Energy and its contractors, in paper from:

U.S. Department of Energy
Office of Scientific and Technical Information
P.O. Box 62
Oak Ridge, TN 37831-0062

Telephone: (865) 576-8401

Fax: (865) 576-5728

E-mail: reports@adonis.osti.gov

RF SOURCES FOR THE ITER ION CYCLOTRON HEATING AND CURRENT DRIVE SYSTEM

J. Hosea^{a*}, C. Brunkhorst^a, E. Fredd^a, R.H. Goulding^b, N. Greenough^a, C. Kung^a, D.A. Rasmussen^b, D.W. Swain^b and J.R. Wilson^a

^a Princeton Plasma Physics Laboratory, PO Box 451, Princeton, NJ 08543, USA

^b Oak Ridge National Laboratory, PO Box 2008, Oak Ridge, TN 37831, USA

Abstract—The RF source requirements for the ITER ion cyclotron (IC) heating and current drive system are very challenging — 20 MW CW power into an antenna load with a VSWR of up to 2 over the frequency range of 35 – 65 MHz. For the two present antenna designs under consideration, 8 sources providing 2.5 MW each are to be employed. For these sources, the outputs of two final power amplifiers (FPAs), using the high power CPI 4CM2500KG tube, are combined with a 180° hybrid combiner to easily meet the ITER IC source requirements — 2.5 MW is supplied at a VSWR of 2 at ~ 70% of the maximum tube power available in class B operation. The cylindrical cavity configuration for the FPAs is quite compact so that the 8 combined sources fit into the space allocated at the ITER site with room to spare. The source configuration is described in detail and its projected operating power curves are presented. Although the CPI tube has been shown to be stable under high power operating conditions on many facilities, a test of the combined FPA source arrangement is in preparation using existing high power 30 MHz amplifiers to assure that this configuration can be made robustly stable for all phases at a VSWR up to 2. The possibility of using 12 sources to feed a suitably modified antenna design is also discussed in the context of providing flexibility for specifying the final IC antenna design.

Keywords- ITER; ion cyclotron; source

I. INTRODUCTION

The baseline ion cyclotron (IC) heating and current drive (H&CD) system for ITER is comprised of a single antenna with sixteen array elements which are fed by eight identical RF power sources in a two row (poloidal) by four column (toroidal) configuration [1,2]. Each of the 8 RF sources is a multistage amplifier and is required to supply 2.5 MW to the antenna in order to meet the total power requirement of 20 MW. The original performance specifications for each of the RF source systems are given in Table I [1]. The requirement of providing 2.5 MW into loads with VSWR values up to 2:1 is very severe and has led the US to propose combining the outputs of two transmitters, each using the high power CPI/EIMAC 4CM2500KG tetrode tube [3], to adequately meet it.

TABLE I. PERFORMANCE SPECIFICATIONS OF THE ICH&CD RF POWER SOURCE

No	Parameter	Value
1	Nominal power output and operation	2.5 MW, CW
2	Average VSWR (any phase)	2.0
3	Transient VSWR on top of average: Dt ~ 1 sec, duty cycle ~ 10%, any phase	2.5
4	Frequency range covered (in bands of 2 MHz)	35 - 65 MHz
5	Frequency deviation over any central frequency (sinusoidal)	± 1 MHz
6	Maximum frequency modulation frequency	1.0 kHz
7	Power modulation range	0.002 - 2.5 MW
8	Maximum amplitude modulation frequency (sinusoidal)	< 10 ms

II. Combined Two Transmitter RF Source Design

The combined RF source design is illustrated in Fig. 1. The outputs of two transmitters are combined with a race-track 180° four-port hybrid for each of the 8 ITER RF source systems.

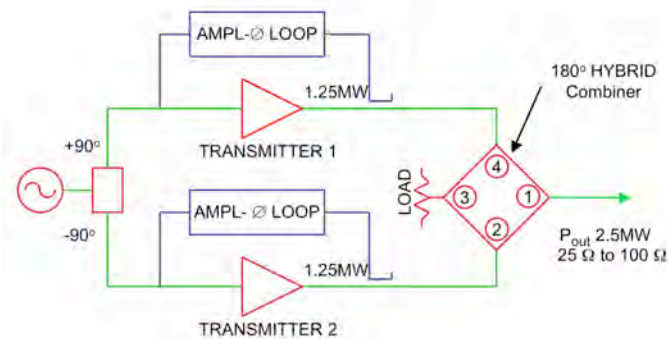

Figure 1. Combined two-transmitter ITER IC RF source design.

Each of the final stage amplifiers of the transmitters utilizes the 4CM2500KG tube to provide for the most robust power output capability that can be obtained with any existing final stage tube for the desired frequency range. This tube has an anode dissipation rating of 2.5 MW and the screen grid design's relatively short electrical length and graphite construction supports a 20 kW dissipation rating. The combined RF source

* Corresponding author. Tel.: 1 609 243 3206;

fax: 1 609 243 2665.

E-mail address: jhosea@pppl.gov (J. Hosea)

system output power versus VSWR as calculated for the tube characteristics [3] is presented in Fig. 2 for Class B operation of the transmitters. As indicated, the combined system comfortably meets the ITER specification for 2.5 MW delivered to the antenna into a VSWR of 2:1 at ~ 70% of the maximum power capability of the tube at this VSWR. Accounting for typical transmission system losses, the maximum available power at the antenna at a VSWR of 2:1 is ~ 3.2 MW (90% of maximum power capability).). Also, it should be possible to sustain the 2.5 MW level for a VSWR excursion to 2.5:1 for short periods of time (~ 90% maximum Class B power capability at this VSWR). Furthermore, for periods time that the VSWR can be held to 1.5:1 or less, as is the goal for the ELM resilient antenna design(s), the combined system can provide ≥ 3.3 MW at 70% of Class B maximum power operation.

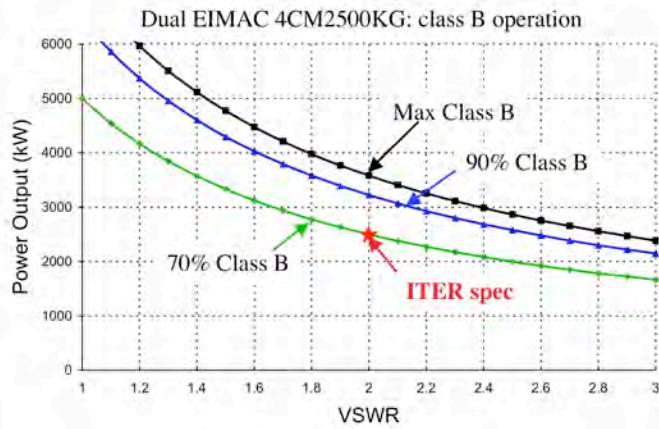

Figure 2. Combined two-transmitter ITER IC RF source output power versus VSWR for Class B operation.

For the combined system, each transmitter’s output is linearized with local amplitude and phase feedback control loops so that the desired amplitudes and phases can be maintained at the transmitter ports of the combiner. The output characteristic for the rat-race combiner can be deduced from those for the rat-race splitter [4] which are shown in Fig.3. The power split versus frequency (power at the input ports) and the mismatch at the input/output ports versus frequency indicate that the combiner can operate satisfactorily over $\pm 10\%$ of the center frequency (f_0) without having to adjust the hybrid leg lengths: $\Delta P_{in} \sim 0.3$ dB and $P_{reflected} \sim -24$ dB at $\pm 10\%$. Thus, several of the frequencies of interest on ITER can be supported without combiner adjustment. Also, by tailoring the amplitudes and phases of the two transmitter outputs, it may be possible to cover all of the heating and current drive scenarios in the 40 – 55 MHz frequency range of primary interest for ITER at present [5].

III. CAVITY/TUBE CONFIGURATION OF THE TRANSMITTERS

The final power amplifier (FPA) stages of the combined system in Fig. 1 have the compact cylindrical design developed for the Fusion Materials Irradiation Facility (FMIT) several years ago by the Continental Electronics Corporation (CEC) [6]. This compact design was maintained when the original

600kW-cw, single-frequency 80 MHz FMIT design, was modified to tune over a 40-80MHz frequency range at 1.5MW output power, under a contract with Oak Ridge National Laboratory, and when further modified by Princeton Plasma Physics Laboratory to provide >2 MW for the TFTR ICRF system. The 4CM2500KG tube fits in the base of a coaxial cylindrical output cavity and grid/cathode connections are

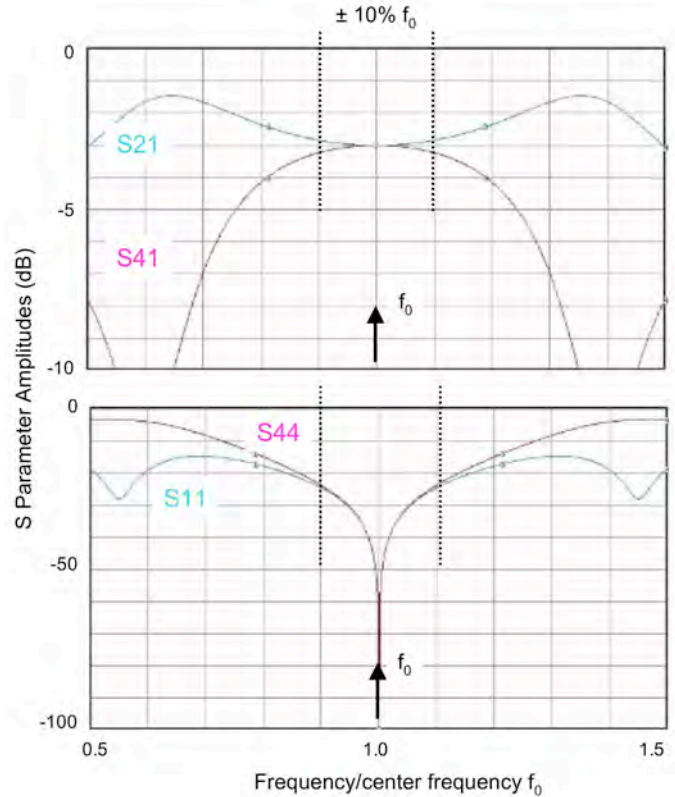

Figure 3. S matrix characteristics versus frequency about the center frequency for the rat-race 180° four-port combiner. (Port numbers are those labeled in Fig. 1).

made with a coaxial feed line. Anode, screen, grid and cathode adapters are shown mounted on the tube in Fig. 4. The anode connector mates with the output cavity center conductor (through a coaxial plate blocking capacitor) and the screen mates with its outer conductor via a Kapton bypass capacitor and aluminum base plate. The cathode connector mates with the center conductor of the input coaxial transmission line whose grounded outer conductor mates with the grid connector. This compact cylindrical design for the transmitters results in a FPA cabinet housing only 1.2 m wide. Thus, the two transmitter combined source easily fits into the ~ 3 m wide space provided in the ITER IC RF source hall.

IV. EXPERIENCE WITH THE FMIT AMPLIFIER DESIGN

The transmitters proposed for ITER are similar to the FMIT sources presently used at GA, MIT, and PPPL to provide up to ~ 2 MW of power for several seconds into loads with VSWR values up to 1.5:1 in the 30 – 80 MHz frequency range. The operation of these sources is very reliable once it is assured that parasitic tube instabilities are damped out. The development

leading up to this reliable operation included: relatively long-pulse high-power tests that were conducted in Japan in 1990 [7] to validate the tube design to $P_{RF} = 1.7$ MW for 5.4 seconds at 131 MHz. Further development of the anode in the US strengthened it to prevent deformation during high VSWR, long-pulse, high-power conditions. The insertion of ferrite tiles on the screen grid connector ring (see Fig. 4) damped out low-level parasitic instabilities well outside the tube operating frequency range (typically in the 1400 – 2000 MHz range). The tiles are reactive at the operating frequency and lossy in the parasitic frequency range. For the very long pulses to be employed on ITER, it will be necessary to tailor the tile composition to make sure that it does not overheat as has been done for the high power, 38.5 MHz, very long pulse (up to 1900 seconds) operation of this tube on LHD in Japan [8].

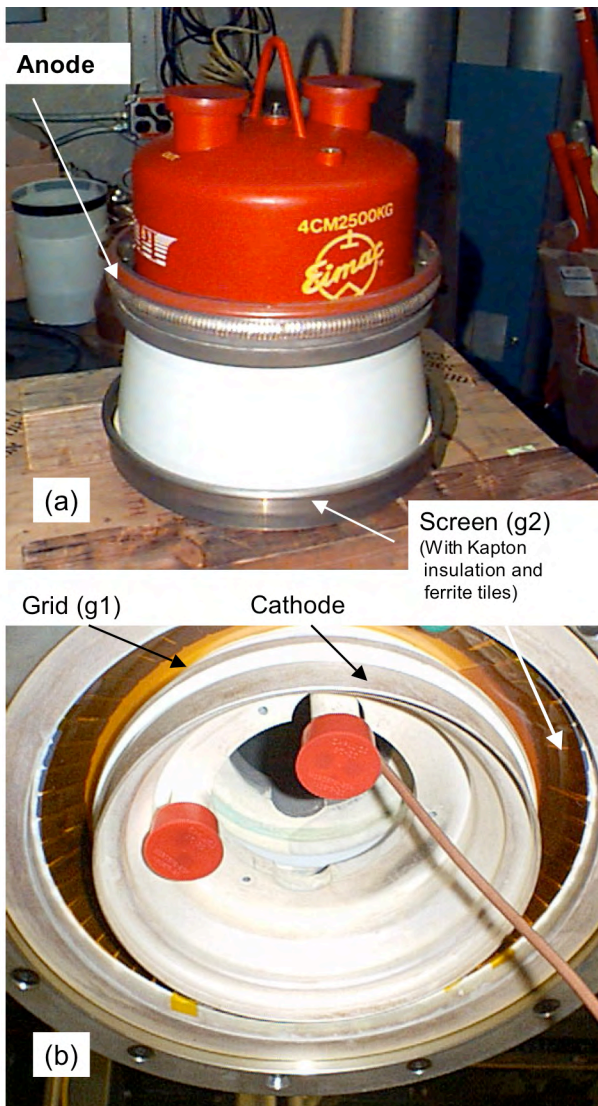

Figure 4. (a) Top and (b) bottom views of 4CM2500KG tetrode showing the anode, screen, cathode and grid adapters/connectors.

In order to gain experience with combining two high-power FMIT sources as indicated in Fig. 1, preparations are now underway to perform load-pull testing of a combined source

system at 30 MHz at the full ITER power specification of $P = 2.5$ MW into a load with a VSWR of 2:1 for a duration of ~ 3 seconds. Two fully operational NSTX HHFW RF sources will be combined and the combiner output will be fed into the dummy load arrangement as shown in Fig. 5. The combiner

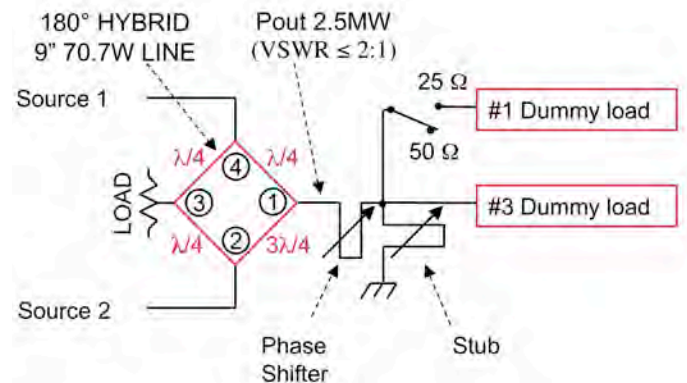

Figure 5. Test arrangement for the two-transmitter source.

output is connected to one or two 3.5 MW/27 MJ 50-ohm dummy loads via coaxial switches, a stub and a stretcher. Testing of the combined two-transmitter source can be conducted at all phase angles for VSWR values up to 2:1. Of particular importance will be to demonstrate stable operation of the two sources at any phase of the load and proper operation of the combiner for high VSWR conditions.

V. SUMMARY

The two tetrode per stage design easily meets the ITER specification of 2.5 MW at a VSWR of 2:1 at only ~ 70% of the maximum Class B power capability. The CPI/EIMAC 4CM2500KG tetrode has been fully developed for high power operation since the early 1990s. It allows 2.5 MW plate dissipation, has adequate screen dissipation (short graphite configuration) and operates very stably in its operating frequency band while parasitic oscillations outside the band are damped out with absorbing tiles. It is also important to note that each tube will generally be operating near 1.25 MW under suitably matched conditions, at which power only ~ 1/2 of the plate dissipation capability will be used, so that a long tube life can be expected. Also, should the antenna support a power greater than 2.5 MW per source system for the lower VSWR values, the combined source has considerable reserve power capacity under these conditions.

Finally, it could result that 12 feeds are ultimately desired for the antenna design. In this case a single transmitter should prove satisfactory for each of the 12 sources required as indicated in Fig. 6. In order to provide the 1.7 MW at a VSWR of 2:1 then required per source to meet the ITER specification for 20 MW at the antenna, tube operation would be at ~ 90% of the maximum Class B, leaving only ~ 10% of the tube output power to cover transmission system losses. Also, no reserve would be available for VSWR excursions to 2.5:1. However, one transmitter easily provides adequate power margin at VSWR values of $\leq 1.5:1$ (~ 2 MW at ~ 80% of the maximum Class B power capability at a VSWR of 1.5:1) and the

matching circuit between the source and antenna should maintain the VSWR ≤ 1.5 .

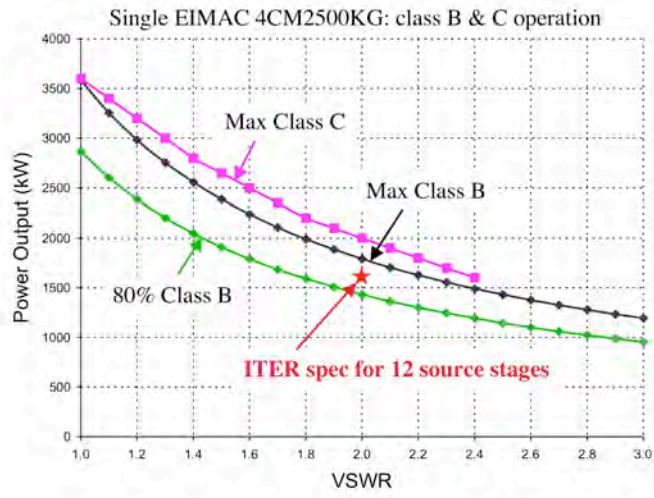

Figure 6. Single tube output power versus VSWR

ACKNOWLEDGMENT

Work supported by DOE Contract No. DE-AC02-76CH03073. Plus ORNL

REFERENCES

- [1] ITER Team, "WBS 5.1 Ion Cyclotron Heating and Current Drive System Procurement Package 51.P3: RF Power Source", ITER-FEAT Procurement Package G 51 SP 7 00-07-27 W0.1 (2000).
- [2] D.A. Rasmussen, R. Ellis, E. Fredd, R.H. Goulding, J. Hosea, B.E. Nelson, and D.W. Swain, "ITER Ion Cyclotron Heating System", at this conference..
- [3] Company Report, "4CM2500KG High Power Tetrode for Science and Industry", Communications and Power Industries (CPI), EIMAC Division (1994).
- [4] Curves obtained from the Microwaves101.com website.
- [5] ITER Team, "Additional Heating and Current Drive Section 2.5", Plant Description Document, ITER Technical Basis G A0 FDR 1 01-07-13 R1.0 (2001).
- [6] M.V. Fazio, W.J. Hoffert, R.D. Patton and R. Sutherland, "A 1-Megawatt CW RF Power Source for 80 MHz", IEEE Transactions on Nuclear Science, Vol. NS-28, No. 3 (1981) 2904.
- [7] D.B. Remsen, C.M. Loring, S.G. McNees, S. Moriyama, Y. Ogawa, K. Anno et al., "Results of Tests of the X2274 High Power Tetrode in a JT-60 110 to 130 MHz ICRH Amplifier", 16th Symposium on Fusion Technology (London 1990) (Elsevier Science Publishers 1991)1156.
- [8] T. Seki, T. Mutoh, R. Kumazawa, K. Saito, T. Watari, Y. Nakamura, et al., "Long Pulse Plasma Heating Experiment by Ion Cyclotron Heating in LHD", 16th Topical Conference on Radio Frequency Power in Plasmas, AIP Conference Proceedings 787 (2005) 98.

External Distribution

Plasma Research Laboratory, Australian National University, Australia
Professor I.R. Jones, Flinders University, Australia
Professor João Canalle, Instituto de Fisica DEQ/IF - UERJ, Brazil
Mr. Gerson O. Ludwig, Instituto Nacional de Pesquisas, Brazil
Dr. P.H. Sakanaka, Instituto Fisica, Brazil
The Librarian, Culham Science Center, England
Mrs. S.A. Hutchinson, JET Library, England
Professor M.N. Bussac, Ecole Polytechnique, France
Librarian, Max-Planck-Institut für Plasmaphysik, Germany
Jolan Moldvai, Reports Library, Hungarian Academy of Sciences, Central Research
Institute for Physics, Hungary
Dr. P. Kaw, Institute for Plasma Research, India
Ms. P.J. Pathak, Librarian, Institute for Plasma Research, India
Dr. Pandji Triadyaksa, Fakultas MIPA Universitas Diponegoro, Indonesia
Professor Sami Cuperman, Plasma Physics Group, Tel Aviv University, Israel
Ms. Clelia De Palo, Associazione EURATOM-ENEA, Italy
Dr. G. Grosso, Istituto di Fisica del Plasma, Italy
Librarian, Naka Fusion Research Establishment, JAERI, Japan
Library, Laboratory for Complex Energy Processes, Institute for Advanced Study,
Kyoto University, Japan
Research Information Center, National Institute for Fusion Science, Japan
Professor Toshitaka Idehara, Director, Research Center for Development of Far-Infrared Region,
Fukui University, Japan
Dr. O. Mitarai, Kyushu Tokai University, Japan
Mr. Adefila Olumide, Ilorin, Kwara State, Nigeria
Dr. Jiangang Li, Institute of Plasma Physics, Chinese Academy of Sciences, People's Republic of China
Professor Yuping Huo, School of Physical Science and Technology, People's Republic of China
Library, Academia Sinica, Institute of Plasma Physics, People's Republic of China
Librarian, Institute of Physics, Chinese Academy of Sciences, People's Republic of China
Dr. S. Mirnov, TRINITI, Troitsk, Russian Federation, Russia
Dr. V.S. Strelkov, Kurchatov Institute, Russian Federation, Russia
Kazi Firoz, UPJS, Kosice, Slovakia
Professor Peter Lukac, Katedra Fyziky Plazmy MFF UK, Mlynska dolina F-2, Komenskeho Univerzita,
SK-842 15 Bratislava, Slovakia
Dr. G.S. Lee, Korea Basic Science Institute, South Korea
Dr. Rasulkhozha S. Sharafiddinov, Theoretical Physics Division, Institute of Nuclear Physics, Uzbekistan
Institute for Plasma Research, University of Maryland, USA
Librarian, Fusion Energy Division, Oak Ridge National Laboratory, USA
Librarian, Institute of Fusion Studies, University of Texas, USA
Librarian, Magnetic Fusion Program, Lawrence Livermore National Laboratory, USA
Library, General Atomics, USA
Plasma Physics Group, Fusion Energy Research Program, University of California at San Diego, USA
Plasma Physics Library, Columbia University, USA
Alkesh Punjabi, Center for Fusion Research and Training, Hampton University, USA
Dr. W.M. Stacey, Fusion Research Center, Georgia Institute of Technology, USA
Director, Research Division, OFES, Washington, D.C. 20585-1290

The Princeton Plasma Physics Laboratory is operated
by Princeton University under contract
with the U.S. Department of Energy.

Information Services
Princeton Plasma Physics Laboratory
P.O. Box 451
Princeton, NJ 08543

Phone: 609-243-2750
Fax: 609-243-2751
e-mail: pppl_info@pppl.gov
Internet Address: <http://www.pppl.gov>