

Stability Regimes of Turbulent Nitrogen-Diluted Hydrogen Jet Flames

N. Weiland¹ and P. Strakey²

¹*National Energy Technology Laboratory, Pittsburgh, Pennsylvania, 15236-0940, USA*

²*National Energy Technology Laboratory, Morgantown, West Virginia, 26507-0880, USA*

One option for combustion in zero-emission Integrated Gasification Combined Cycle (IGCC) power plants is non-premixed combustion of nitrogen-diluted hydrogen in air. An important aspect to non-premixed combustion is flame stability or anchoring, though only a few fundamental stability studies of these flames have taken place to date. The following paper presents the results of experiments investigating the effects of nitrogen diluent fraction, jet diameter, and exit velocity on the static stability limits of a turbulent hydrogen jet flame issuing from a thin-lipped tube into a quiescent atmosphere. Four different stability limits are observed: detachment from the burner lip, reattachment to the burner lip, transition from a laminar lifted flame base to blowout or to a turbulent lifted flame, and transition from a turbulent lifted flame to blowout. The applicability of existing theories and correlations to the stability results is discussed. These results are an important step in assessing the viability of a non-premixed combustion approach using hydrogen diluted with nitrogen as a fuel.

1. Introduction

In the U.S. Department of Energy's FutureGen program, the current IGCC cycle design calls for the combustion of a mixture of roughly equal parts hydrogen and nitrogen within the gas turbine combustor. In order to avoid flashback and auto-ignition issues associated with the use of hydrogen fuel, an array of small diffusion flames is being considered as a means to achieve the NO_x emission goal of 2 ppmvd, corrected to 15% O₂. In particular, reductions in NO_x emission from this type of burner will primarily be accomplished through reductions in flame residence time, which are attained by reducing the fuel jet's exit diameter and increasing its velocity.

Due to the desire to operate at high velocities, static stability of these hydrogen/nitrogen diffusion flames becomes a high priority, and little existing data is available to help predict the stability limits of these flames. The following study is focused on determining these stability limits and understanding how they are affected by the physical attributes of the combustor. In addition, as most stability models in existence are tailored to the combustion of hydrocarbons, correlations that correspond to the various stability limits will be evaluated to aid in the future design of stable diffusion flame combustors operating on hydrogen/nitrogen mixtures.

The primary stability limits of concern are the blowout velocity, the velocity at which a lifted flame completely blows out, and the blowoff velocity, in which a burner-attached flame blows out. Of the many experimental studies on turbulent diffusion flame blowout [1-8], several report the use of hydrogen as a base fuel [4-8], and only a few have studied diluted hydrogen fuels [6-

8]. The experiments of Vranos et. al. [4] were the first true study of hydrogen/air diffusion flame stability limits, though the study was mostly qualitative in nature, and focused more on stability regimes with regard to injector lip thickness and elevated coaxial air velocities. These issues will be important in the implementation of hydrogen/nitrogen diffusion flames in a gas turbine combustor, but do not consider the effect of nitrogen dilution. In the following study, the stability of the fuel jet is first quantified in terms of the nitrogen dilution level for a thin-lipped tube into a quiescent atmosphere. Studies investigating the additional effects of air velocity and tube lip thickness for hydrogen/nitrogen fuels are planned for future studies.

The work of Kalghatgi [5] establishes blowout limits for flames using a variety of fuels, including hydrogen, work that was extended by Chao and co-workers to account for the effects of fuel dilution [6]. These studies concentrate more on the blowout limits of hydrocarbons than on those for hydrogen, however, and the blowout correlation developed by Kalghatgi is empirically tailored to the hydrocarbon fuel results [5, 8]. The study of Shebeko and co-workers also provides some limited blowout data for nitrogen diluted hydrogen flames, but uses a nozzle-type fuel injector and a heated air supply [7].

The study of Cheng and Chiou [8] provides the most varied study to date on the stability regimes of hydrogen jet flames, though all of these experiments were performed using an un-contoured converging nozzle rather than a straight pipe, and the resulting differences in the jet exit velocity profiles can have a significant influence on the stability characteristics of the jet flame [9, 10]. Qualitatively, however, their data shows that for various jet diameters and varying degrees of partial premixing of hydrogen and air, that diluted hydrogen jet flames exhibit both blowoff from attached flames at high dilution levels, and blowout from lifted flames at lower dilution levels [8]. In addition, their analysis shows that the blowout model of Broadwell and co-workers [11] fits their experimentally observed blowout velocities fairly well, though the competing correlation by Kalghatgi [5] is not tested.

The phenomenon of blowoff of an attached flame seems to be mostly limited to hydrogen flames [6], and thus it has not received as much attention as the blowout stability mechanism. The most extensive study on the subject was performed by Takahashi and colleagues [12], where the liftoff and blowoff velocities of diluted hydrogen jet flames were determined for various jet diameters and diluents. Although their results show that reducing the jet diameter increases the liftoff or blowoff velocity [12], it is important to note that their data were not corrected for compressibility effects, while the compressibility-corrected data of Cheng and Chiou [8] show that the blowoff velocity is independent of jet diameter.

One important attribute of hydrogen jet flames that contribute to its varied stability characteristics is the fact that for burner-attached flames, radial diffusion of hydrogen out of the jet core establishes a combustible mixture outside the jet shear layer, leading to a laminar flame base in this location. Further work by Takahashi and colleagues shows that the liftoff and blowoff stability limit in these flames is reached when the axial velocity of the entrained air exceeds the maximum laminar burning velocity at the location of the flame base [13]. When this occurs, the flame either blows off of the burner or re-establishes itself as a lifted flame with a laminar base at a liftoff height of 2-5 jet diameters above the burner.

In cases where a lifted flame is established, reduction of the jet exit velocity well below the liftoff velocity will cause the flame to reattach itself to the burner rim, frequently referred to as dropback [8] or reattachment [9, 14]. The dropback velocity establishes a lower limit to the

region where stable lifted flames can exist, flames which may be desirable in gas turbine combustion to reduce heat transfer to the burner's surface.

2. Experimental Apparatus

The combustor used for all of the atmospheric pressure measurements in this study is shown to scale in Figure 1. Ultra high purity hydrogen and nitrogen are individually metered from gas cylinders to the fuel tube using separate mass flow controllers. The fuel tubes are made from 1/8" OD stainless steel tubing with varying wall thicknesses, each gradually tapered to a thin lip at the jet exit, with measured jet exit diameters, d_0 , of 0.84 mm, 1.45 mm, and 2.12 mm. A thermocouple mounted in 1/4" tubing just upstream of the fuel tube measures an approximate stagnation temperature of the hydrogen/nitrogen mixture, and a pressure transducer measures the pressure in the combustion chamber, allowing compressibility-corrected jet exit velocities and densities to be calculated. Another mass flow controller delivers high purity air to the coflow air apparatus, consisting of a packed bed of copper beads overlaid with a stack of wire mesh screens. In all cases, the coflow air is supplied at an equivalence ratio of $\Phi = 0.5$ or 0.33 , and its velocity calculated to be less than 0.25% of the fuel jet velocity.

For stability studies, the flame is shielded from air drafts in the laboratory with an 8" Pyrex cylinder. This differs from many experimental stability studies in that the jet flame is enclosed, however, it is more representative of gas turbine conditions, as is the use of air delivery at $\Phi = 0.5 - 0.33$. The Pyrex cylinder can be cooled via ambient air flow through eight 1/2" holes around the base of the combustion chamber as shown in Fig. 1, though these holes were sealed for all experiments in this study, as cooling was deemed unnecessary.

Experiments were performed on each of the three fuel jet diameters, with hydrogen diluted by up to 60% nitrogen. For all stability limits, experiments were performed at fixed hydrogen and air flowrates, while the nitrogen flow was slowly increased or decreased until a change in flame stability was observed. For velocities and nitrogen diluent fractions where both lifted and attached flames were possible, ignition of the flame either above or on the burner rim was used to attain lifted or attached flames, respectively. Each measurement was repeated 2-4 times, and at higher nitrogen dilutions, the laboratory was darkened to enhance flame visibility.

3. Results and Discussion

In the course of the experimentation, it was found that two different types of lifted flames can exist in hydrogen/nitrogen jet flames, a behavior that has not been reported in literature to date. The first type of lifted flame has a narrow flame base that sits 2-6 jet diameters above the burner. The base of this flame is very steady, appears laminar in nature, and largely exists outside the jet shear layer of the burner. The other flame is a lifted flame with a much wider, unsteady flame base that is anchored 10 or more jet diameters above the burner. This flame is very noisy, and

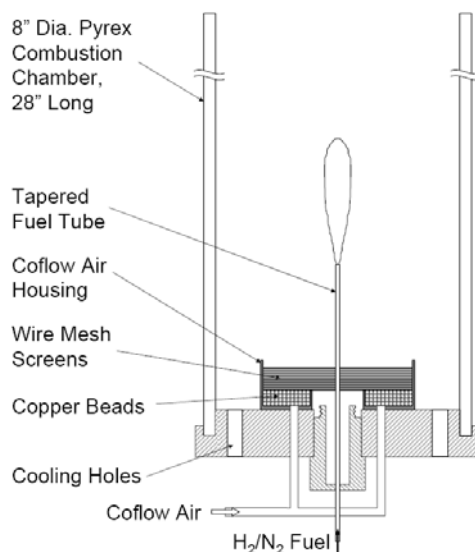

Figure 1: Experimental apparatus for atmospheric pressure NO_x measurements

it's base appears turbulent in nature. The existence of the two types of lifted flames is similar in appearance and structure to those observed in diluted propane jet flames [14].

Noting the distinction between the two types of lifted flames, the stability map in Figure 2 shows four separate stability mechanisms that establish the boundaries of four jet flame conditions that are possible for the 1.45 mm jet: an attached flame, lifted flame with a laminar or turbulent flame base, and region where stable flames cannot exist for this burner. Overlapping regions indicate areas where either flame type can exist stably, depending on the ignition location or other transient phenomena.

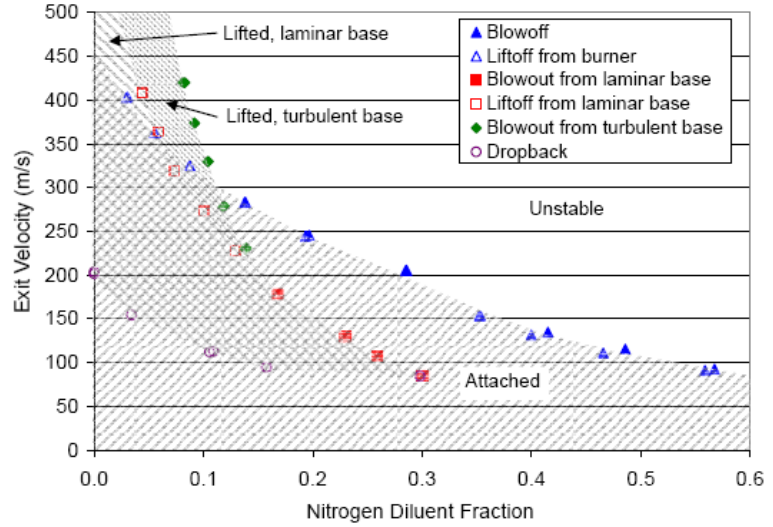

Figure 2: Stability map for jet diameter = 1.45 mm

For flames that are attached to the burner, velocity or nitrogen diluent fraction can be increased until the detachment flame limit is reached. After detachment, the flame can either blowoff the burner (nitrogen content > 11%) or stabilize further downstream in a lifted flame with either a laminar ($N_2 < 6\%$) or a turbulent ($6\% < N_2 < 11\%$) flame base. As mentioned above, this limit is governed by the stability criterion of Takahashi and colleagues, where increasing jet velocity increases the entrained air velocity until it exceeds the maximum laminar flame speed of the diffusion-controlled gas mixture at the flame base, detaching the flame from the burner [13].

Figure 3 shows the detachment stability limit for all three jet diameters tested. The results seem to indicate a slight dependence on jet diameter, however, some of the results are affected by flow dynamics within the combustion chamber. Particularly at higher nitrogen diluent fractions, higher equivalence ratios, and larger jet diameters, it is observed that the air flow supplied to the combustion chamber is not sufficient to satisfy the mass entrainment needs of the jet, resulting in recirculation vortices of hot combustion products that encroach on the flame from the side. This causes local extinction of the flame at these locations, and occasionally, premature blowoff of the flame. At a lower equivalence ratio of $\Phi = 0.33$, the increased air flow is enough to prevent this from occurring at the base of the flame, and blowoff velocities generally increase, as seen in Fig. 3. Recirculation vortices still occur, but at locations much farther downstream from the jet exit.

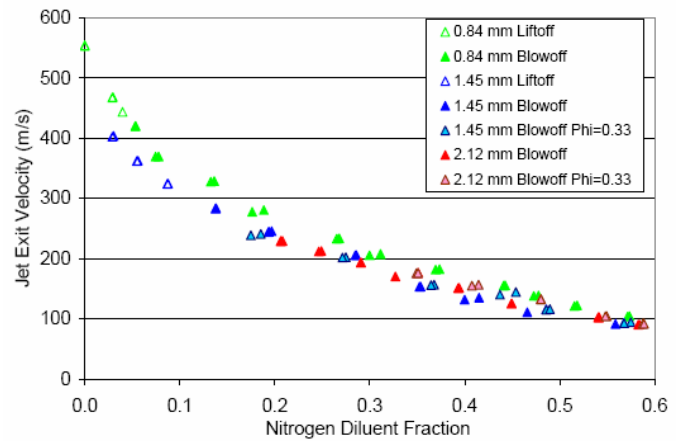

Figure 3: Detachment stability limit for all jet diameters with $\Phi = 0.5$ unless otherwise noted

To test the effects of the combustion chamber itself on flame detachment, a set of free jet experiments were run using the 0.84 mm jet diameter. In these experiments, the Pyrex cylinder was removed from the burner apparatus, no coflow air was supplied to the flame, and the exit of the fuel tube was extended from 3¼” to 6” above the coflow air housing to reduce interactions between the base of the combustor and the room air entrained into the flame. These results are presented in Figure 4, where it can be seen that the detachment velocity of the free jet is about 20 m/s higher than that of the enclosed jet, possibly due to slightly higher air velocities at the base of the flame from the coflow section of the enclosed burner.

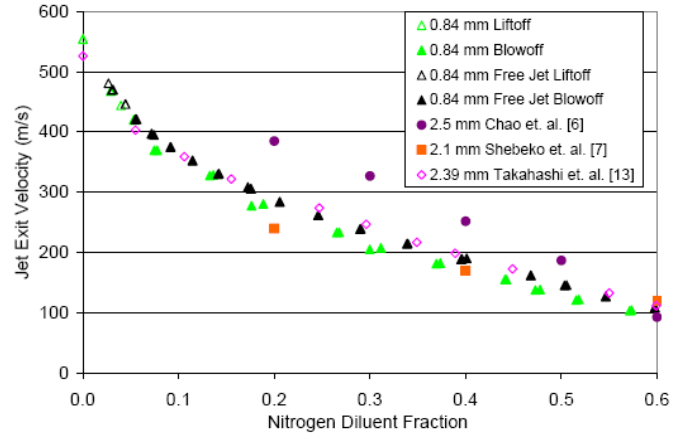

Figure 4: Detachment stability limit for free and enclosed jets

Also plotted in Fig. 4 are other blowoff results of turbulent, nitrogen-diluted hydrogen jet flames found in the literature [6, 7, 13]. The results of Chao et. al. [6] yield higher blowoff velocities than the other studies, and while the tip condition of the jet in their work is unspecified, such a result could occur for a blunt-tipped fuel tube with an appreciable lip thickness [4]. The results of Shebeko et. al. [7] are quantitatively similar to the present study, though the shallower slope with respect to nitrogen diluent fraction may be due to the nozzle configuration used in that study. The free jet results of the present study are in quite good agreement with those of Takahashi and colleagues [13], whose experimental setup of is most similar to that of the current work. The excellent agreement occurs in spite of the widely differing jet diameters, verifying that the detachment stability limit is independent of jet diameter.

For flames that detach from the burner and restabilize downstream as a lifted flame with a laminar base, decreasing the jet velocity will result in upstream flame propagation and reduction in liftoff height until sudden reattachment to the burner occurs [4, 8, 9, 14-16]. The reattachment occurs when the decreasing jet exit velocity reduces the entrained air velocity at the flame base below the maximum laminar flame speed of the fuel/air mixture flowing into the flame base, allowing upstream propagation of the flame. The hysteresis between liftoff and reattachment is the result of a change in the turbulence and air entrainment characteristics once the flame has lifted, and indicates the importance of the reduced flame density in determining the air entrainment pattern at the flame base [14-16].

The dropback stability limit is a significant function of the jet exit diameter, as shown in Figure 5, and defines the lower boundary in which a stable lifted flame with a laminar base can exist. The upper boundary of this region is shown in Fig. 2 for the 1.45 mm jet diameter, where increasing the jet velocity of a lifted flame with a laminar base will either result in a transition to a lifted flame with a turbulent base (<15% N₂, “T. Liftoff” in Fig. 5), or a blowout condition (>15% N₂, “L. Blowout” in Fig. 5). The data shown in Fig. 5 indicates that this transition is independent of jet diameter, while the dropback velocity decreases for increasing jet diameter, effectively extending the range of nitrogen diluent fractions for which lifted flames with a laminar base are possible (e.g., from 20% N₂ for $d_0 = 0.84$ mm to 30% N₂ for $d_0 = 1.45$ mm).

It is important to note that the transition from a lifted flame with a laminar base to a lifted flame with a turbulent base is not a smooth transition. The data shown in Figs. 2 and 5 represents the onset of this transition as the jet exit velocity increases, since this is the condition that would also result in blowout from a lifted flame with a laminar base, thus yielding the smooth curve that is independent of jet diameter and whether blowout or a lifted flame with a turbulent base is the result of this transition. For the two-stage lifting process, as it is termed by Prasad et. al. [14], there is a small transition region in which the flame randomly alternates between the two lifted states. As the jet velocity is increased over a span of about 10-20 m/s above the stability limit noted in Fig. 5 (“T. Liftoff”), the probability of seeing a lifted flame with a turbulent base increases from 0% to 100%. This behavior is different than that previously reported in the literature for nitrogen-diluted propane flames [14], as no hysteresis is evident in the shift between the two lifted flame regimes in this study.

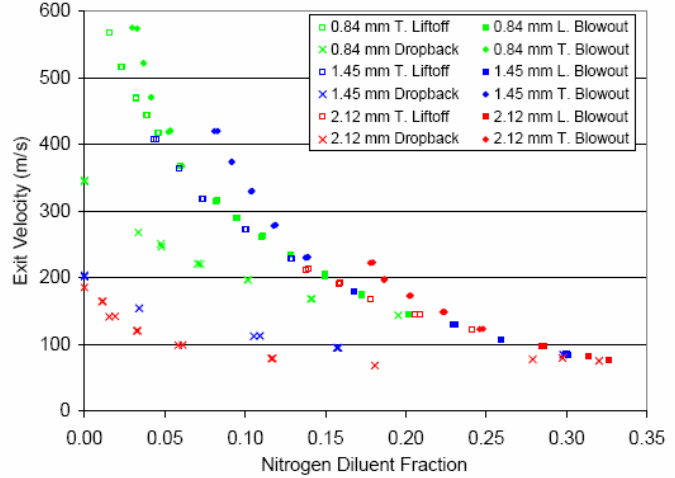

Figure 5: Dropback, turbulent liftoff and blowout limits for all jet diameters.

For lifted flames with a turbulent base, as the jet velocity is increased the liftoff height increases until the flame blows out at the blowout velocity shown in Fig. 5. This process has been the subject of considerable attention [1-6, 11, 17], with the most referenced blowout models being those of Kalghatgi [5] and Broadwell and coworkers [11]. Kalghatgi’s correlation is based on a turbulent premixed flame model that was empirically fit to blowout data acquired on several fuels and fuel-diluent mixtures, resulting in the following formula [5]:

$$u_b = S_{L,max} \left(\frac{\rho_\infty}{\rho_0} \right)^{1.5} 0.017 Re_H \left(1 - 3.5 \times 10^{-6} Re_H \right), \quad (1)$$

where u_b is the blowout velocity, $S_{L,max}$ is the maximum laminar flame speed, ρ_∞ is the ambient air density, ρ_0 is the jet exit density, and $Re_H = HS_{L,max}/\nu_0$ is a Reynolds number based on ν_0 , the fuel kinematic viscosity at the jet exit, and H , the axial distance above the burner at which a stoichiometric fuel/air mixture exist. The formula for H is given by [18]:

$$H = d_0 \left[4 \frac{Y_{f,e}}{Y_{f,s}} \left(\frac{\rho_0}{\rho_\infty} \right)^{1/2} + 5.8 \right], \quad (2)$$

where $Y_{f,0}$ is the mass fraction of fuel at the jet exit and $Y_{f,s}$ is the stoichiometric fuel mass fraction of the mixture of air and jet fluid.

In the competing model of Broadwell et. al. [11], lifted flames with a turbulent base are stabilized by large-scale vortices that carry hot combustion products into eddies of unburned fuel and ignite them, stabilizing the flame. The blowout stability limit is reached when the

characteristic turbulent mixing time is smaller than some constant, ε , times the characteristic chemical time, resulting in rapid cooling of the combustion products and insufficient time for ignition of the unburned fuel in the eddy. This criterion results in the following formula [11]:

$$u_b = \frac{d_0 S_{L,max}^2 \psi^2 \left(\frac{\rho_0}{\rho_\infty} \right)^{1/2}}{\varepsilon \kappa}, \quad (3)$$

where ψ is the stoichiometric air to fuel mass ratio and κ is the thermal diffusivity of a stoichiometric fuel/air mixture.

Common to both of these models is the maximum laminar flame speed of the mixture of fuel jet fluid and air. Flame speed calculations using the PREMIX code of the Chemkin software package and the hydrogen combustion mechanism of Li et. al. [19] are shown in Figure 6. Also shown for comparison are the data of Takahashi and colleagues [13] and the experiments of Qiao et. al. [20]. The calculations are a good match of the Qiao et. al. data, which were taken at an equivalence ratio of 1.8 since this air/fuel ratio typically corresponds to the maximum laminar flame speed of a hydrogen/air mixture [20].

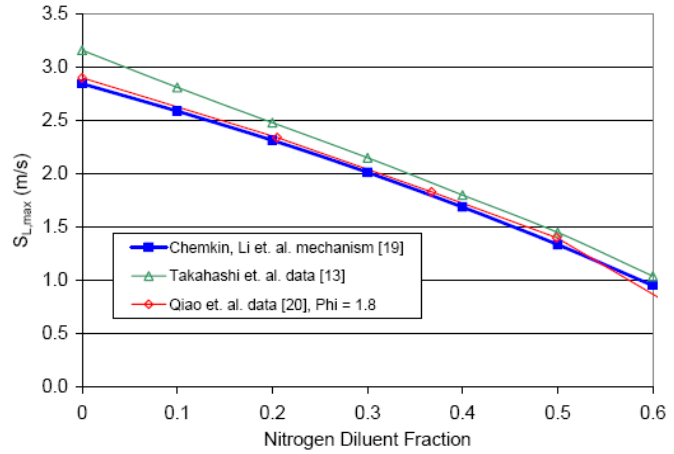

Figure 6: Maximum laminar flame speed vs. nitrogen diluent fraction of the hydrogen fuel

The computed values of $S_{L,max}$ in Fig. 6 are used to calculate the blowout velocities predicted by Kalghatgi [5] and Broadwell et. al. [11] in Eqs. (1) and (3), respectively, and the results are plotted along with the experimental blowout velocities attained for each jet diameter in Figure 7. As is evident in the figure, the blowout correlation of Broadwell and colleagues [11] performs much better than that of Kalghatgi [5], which overpredicts the blowout velocity by a factor of 2.5 – 4.5. This occurs because the correlation of Kalghatgi is empirically tailored to hydrocarbons, which have much larger values of Re_H than do diluted hydrogen fuels. In the calculation of the blowout velocity using Eq. (3), κ is the thermal diffusivity of air at 2000 K and $\varepsilon = 4.4$ as suggested by Broadwell et. al. [11]. This value of ε is based on a single data point however, and an average of the data taken here yields a best fit correlation for a value of $\varepsilon = 4.54$.

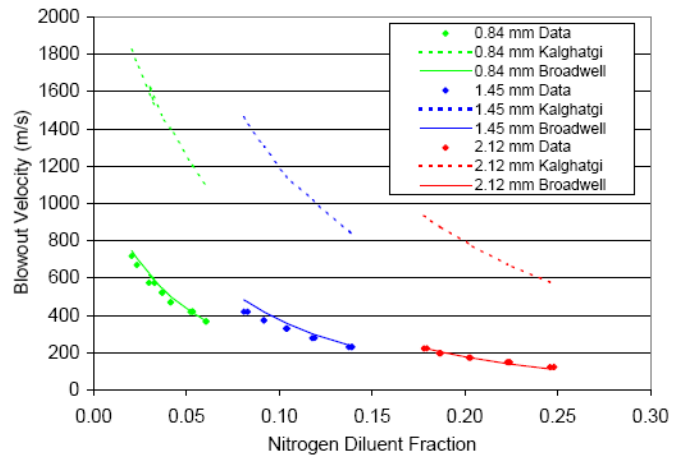

Figure 7: Experimental blowout velocities and blowout correlations for each jet diameter

4. Conclusions

The conclusions of this study can be summarized as follows:

1. Similar to diluted propane flames [14], turbulent hydrogen/nitrogen diffusion flames can exist as attached flames or as lifted flames with either a laminar or turbulent base.
2. The detachment stability limit that bounds the upper velocity of an attached flame is independent of jet diameter in the absence of recirculation vortices in the combustor.
3. The stability limit at which a lifted flame with a laminar base transitions to blowout or a lifted flame with a turbulent base is independent of jet diameter.
4. The blowout velocity correlation of Broadwell et. al. [11] is much more accurate for hydrogen/nitrogen flames than the correlation of Kalghatgi [5], and best fits the experimental data with a blowout parameter of $\epsilon = 4.54$.

Acknowledgements

The authors would like to thank Fred White for his assistance in the setup of the atmospheric pressure combustor. The support of the U.S. DOE Turbines program is also gratefully acknowledged.

References

- [1] Vanquickenborne, L., and van Tiggelen, A., *Combust. Flame*, 10:59-69, (1966).
- [2] Dahm, W. J. A., and Mayman, A. G., *AIAA J.*, 28(7):1157-1162, (1990).
- [3] Tieszen, S. R., Stamps, D. W., and O'Hern, T. J., *Combust. Flame*, 106:442-466, (1996).
- [4] Vranos, A., Taback, E. D., and Shipman, C. W., *Combust. Flame* 12:253-260 (1968).
- [5] Kalghatgi, G. T., *Combust. Sci. Technol.*, 26:233-239, (1981).
- [6] Chao, Y. C., Wu, C. Y., Lee, K. Y., Li, Y. H., Chen, R. H., and Cheng, T. S., *Combust. Sci. Technol.*, 176: 1735-1753, (2004).
- [7] Shebeko, Y. N., Korolchenko, A. Y., Zamishevski, E. D., Trunev, A. V., Navzenya, V. Y., and Zaitzev, A. A., *Combust. Flame*, 117:438-440, (1999).
- [8] Cheng, T. S. and Chiou, C. R., *Combust. Sci. Technol.*, 136:81-94, (1998).
- [9] Coats, C. M., and Zhao, H., *Twenty-Second Symp. (Int.) Combust.*, The Combustion Institute, Pittsburgh, PA, 685-692, (1988).
- [10] Eickhoff, H., Lenze, B., and Leuckel, W., *Twentieth Symp. (Int.) Combust.*, The Combustion Institute, Pittsburgh, 311-318, (1984).
- [11] Broadwell, J. F., Dahm, W. J. A., and Mungal, M. G., *Twentieth Symp. (Int.) Combust.*, The Combustion Institute, Pittsburgh, 303-310, (1984).
- [12] Takahashi, F., Mizomoto, M., and Ikai, S., *Hydrogen Energy Progress* (T. N. Veziroglu, Ed.), P.1165, Pergamon Press, (1980).
- [13] Takahashi, F., Mizomoto, M., Ikai, S., and Futaki, N., *Twentieth Symp. (Int.) Combust.*, The Combustion Institute, Pittsburgh, 295-302, (1984).
- [14] Prasad, A., Gundavelli, S., and Gollahalli, S. R., *J. of Propulsion and Power*, 7:659-667, (1991).
- [15] Gollahalli, S. R., Savaş, Ö., Huang, R., and Rodriguez Azara, J. L., *Twenty-First Symp. (Int.) Combust.*, The Combustion Institute, Pittsburgh, 1463-1471, (1986).
- [16] Scholefield, D. A., and Garside, J. E., *Third Symp. (Int.) Combust.*, Williams and Wilkins, 102-110, (1949).
- [17] Pitts, W. M., *Twenty-Third Symp. (Int.) Combust.*, The Combustion Institute, Pittsburgh, 661, (1990).
- [18] Birch, A. D., Brown, D. R., Dodson, M. G., and Thomas, J. R., *J. Fluid Mech.*, 88(3):431 (1978).
- [19] Li, J., Zhao, Z., Kazakov, A., and Dryer, F., *Int. J. Chem. Kinetics*, 36:1-10, (2004).
- [20] Qiao, L., Kim, C. H., and Faeth, G. M., *Combust. Flame*, 143:79-96, (2005).