

INL/CON-05-00013
PREPRINT

INL SUBSURFACE WIRELESS SENSOR PLATFORM

**21st Annual International Conference
on Soils, Sediments and Water**

Dennis C. Kunerth
John M. Svoboda
James T. Johnson

October 2005

The INL is a
U.S. Department of Energy
National Laboratory
operated by
Battelle Energy Alliance



This is a preprint of a paper intended for publication in a journal or proceedings. Since changes may not be made before publication, this preprint should not be cited or reproduced without permission of the author. This document was prepared as an account of work sponsored by an agency of the United States Government. Neither the United States Government nor any agency thereof, or any of their employees, makes any warranty, expressed or implied, or assumes any legal liability or responsibility for any third party's use, or the results of such use, of any information, apparatus, product or process disclosed in this report, or represents that its use by such third party would not infringe privately owned rights. The views expressed in this paper are not necessarily those of the United States Government or the sponsoring agency.

INL SUBSURFACE WIRELESS SENSOR PLATFORM

Dennis C. Kunerth, John M. Svoboda, and James T. Johnson
Idaho National Laboratory, Idaho Falls, ID 83415

Abstract: The Idaho National Laboratory is developing a versatile micro-power sensor interface platform for periodic subsurface sensing of environmental variables important to waste disposal sites such as volumetric moisture, water potential, and temperature. The key characteristics of the platform architecture are that the platform is passive until externally energized—no internal power source is required—and that it communicates with a "reader" via short-range telemetry—no wires penetrate the subsurface. Other significant attributes include the potential for a long service life and a compact size that makes it well suited for retrofitting existing landfill structures. Functionally, the sensor package is "read" by a short-range induction coil that activates and powers the sensor platform as well as detects the sensor output via a radio frequency signal generated by the onboard programmable interface controller microchip. As a result, the platform has a functional subsurface communication range of approximately 10 to 12 ft. and can only accept sensors that require low power to operate.

Key words: Wireless; sensor platform; subsurface sensing; moisture; water potential.

1. INTRODUCTION

For many of the soil waste sites within the Department of Energy complex, in-place containment with surface barriers (caps) is expected to be the primary means of remediation. As part of the capping process, there will be years of post-closure monitoring to assure/verify performance. Consequently, monitoring technologies are needed that are economical, reliable, require low-maintenance, and have the potential for a long service

life. Implementation techniques will need to minimize the impact of the monitoring technology on cap integrity.

An example is found at DOE's Hanford Site. The 200 Areas of the Hanford Site are on the National Priorities List under the Comprehensive Environmental Response, Compensation and Liability Act (CERCLA) of 1980. Operations in the 200 Areas were related to separation of nuclear materials from spent nuclear fuel. Significant quantities of chemical and radioactive waste, as well as chemicals associated with the separations processes, were disposed to the environment. The 200 Areas contain about 800 soil waste sites, including liquid disposal structures, solid waste burial sites, and spills. Types of waste received at these sites include radioactive, mixed radioactive, hazardous, sanitary, and demolition waste. The use of surface barriers (caps) is expected to be the preferred approach to containment as identified in the DOE-RL baseline (DOE-RL, 1999a). Barrier performance data are needed for remediation decisions and, if barriers are selected, to verify their performance.

A number of different methodologies are used to monitor the performance of barrier caps, including monitoring wells, bore hole sampling/sensing, lysimeters, and networks of embedded sensors wired to data loggers or telemetry units. The wires associated with embedded systems can present difficulties during construction and subsequent cap maintenance because the wires penetrate the cap, providing potential paths for water infiltration. Any maintenance of the sensors after extended service also means additional penetrations and disruption of barrier integrity. An approach to mitigate a number of these issues is to implement a sensor platform that is wireless and passive with the potential for extended service. In most cases, platform service life will be limited to the useful service life of the integrated sensors interacting with the environment.

The Idaho National Laboratory (INL) is developing a sensor platform that is both wireless and passive. Passive is defined as not having an onboard power supply. The platform architecture has the following attributes: 1) all platform components are inactive until energized by an external power source, thus no internal power such as a battery is required; 2) a magnetic induction field generated by a "reader" is used to both power and communicate with the platform, eliminating the need for wires to penetrate to the subsurface; 3) sensor platforms are individually addressable, allowing a single reader to interrogate a number of different platforms; and 4) each platform can support multiple low-power sensors. Although well suited for the intended application, this approach does have inherent limitations and/or tradeoffs. These include a limited functional range, as defined by the extent of the interrogating induction field, and a power budget, as defined by the onboard energy storage capacitors that provide power to platform

components as well as integrated sensors. Specific applications require tradeoffs between charge time (measurement cycle time), available power, and working depth. For example, an increase in required power to run sensors will result in either a reduced working depth and/or an increase in charge time. A working configuration as it relates to a landfill cap is illustrated in Figure 1.

2. MATERIAL AND METHODS

The platform is designed around a microcontroller produced by Microchip Technology.¹ In essence, it is a single-chip computer containing onboard nonvolatile memory, multiple analog-to-digital (A/D) channels, and digital communication ports. The microcontroller can be programmed and/or hardwired to handle all of the logic needed for power management, opera

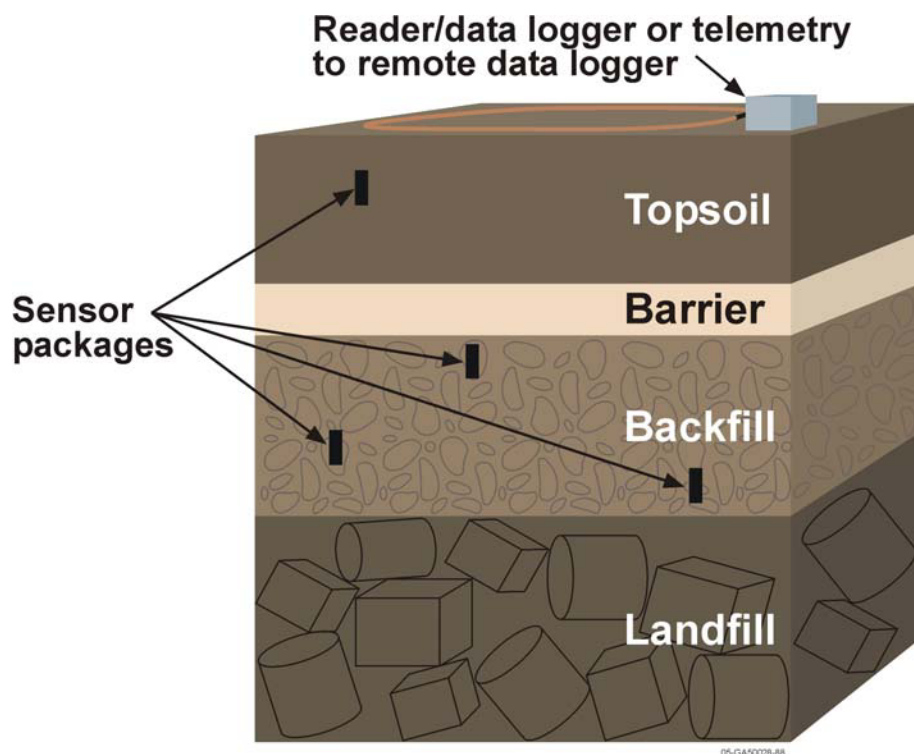

Figure 1. Functional configuration for INL sensor platform as it relates to a landfill barrier cap.

¹ Microchip Technology Inc., Programmable Interface Controller PIC16F877A.

tion of one or more sensors, and communication with the reader. hardwired to handle all of the logic needed for power management, operation of one or more sensors, and communication with the reader. Associated with the microcontroller are circuits to communicate as well as collect and store energy from the aboveground reader. Telemetry and power transfer between the reader and sensor platform are accomplished through a low-frequency magnetic field (nominal 125 kHz working frequency). The reader is a conventional radio transceiver connected to a resonant antenna.

The basic sequence to acquire sensor readings is as follows. The reader sends out energy in the form of an alternating magnetic field, which is captured and stored in a capacitor within the platform/sensor package. When sufficient energy has been collected, the microcontroller will initiate a routine to have one or more sensors perform a measurement. The values collected (e.g. volumetric moisture, temperature, and/or pressure) are then digitized. At that point, the microcontroller powers the probe transmitter and also controls frequency-shift keying to impress the digital readings on the transmitted waveform, with subsequent decoding by the reader. The reader supplies instructions to the platform, as well as energy. For example, the platform might be instructed to report the value of a particular onboard sensor or to adjust the operating range of a sensor.

Figure 2 shows a simplified block diagram of the probe. The antenna, actually a resonant circuit, is used both for capturing energy from the reader and transmitting data back to the reader. As energy builds in the storage capacitor, the microcontroller begins to operate and polls the energy detector circuit to determine if the capacitor is fully charged, i.e. has a 5 Volt reserve available for use. When that condition is achieved, the RF detection circuit is polled to determine if the reader is still transmitting the energizing pulse. If not, the reader has stopped to listen. If so, the microcontroller interrogates the sensor(s), which requires applying power and digitizing its analog output. At this point, the measurement results are stored in the microcontroller's memory. Power is then applied to the transmitter, which in turn drives the antenna. Frequency-shift keying is accomplished by switching a small capacitance in and out of the resonant circuit of the antenna; the switching is controlled by the communications port on the microcontroller. The receiving process is straightforward. An FM receiver is tuned such that its passband is centered on one of the frequency components of the modulated wave. This produces analog output from the receiver that is level shifted to become a proper RS-232 signal. That signal is captured by the serial port of a computer, which serves as the data logger.

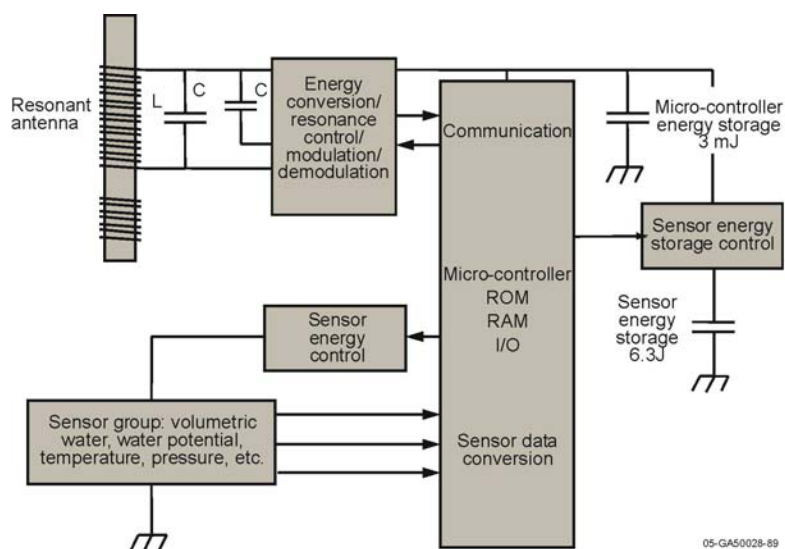

Figure 2. Simplified block diagram of the sensor platform and reader.

3. RESULTS

To date, the development of the INL sensor platform has progressed from a breadboard model demonstrating feasibility (Kunerth et al., 2001) to a number of prototype models that have been tested in the field.

Early prototype platforms with temperature, pressure, and volumetric water sensors were developed and tested at a moisture sensor calibration facility at the Nevada Test Site (NTS) developed for the calibration of neutron moisture meters in different well casing types. This facility consists of arrays of time domain reflectometry (TDR) probes buried at depths of 1, 2, and 3 feet in screened alluvium. TDR probes measure water content. The TDR probes were calibrated in the laboratory using NTS alluvium prior to installation in the field and provide accurate measurements of volumetric water content. Use of this facility permitted the direct comparison of the INEEL sensor technology to an accepted moisture measurement technology. Four prototype sensor packages were buried at various depths in the NTS facility within the sensing volume of the TDR arrays. Subsequent to burial, the area was flooded and the water infiltration recorded with time, see Figure 3. Figure 4 presents the volumetric water measurements recorded for INL sensor package #3 with time. Figure 5 shows the volumetric water measurements made by TDR sensors at the 1-ft level. Spaces in the data resulted from alternating measurements between the TDR probes and the



Figure 3. INL wireless sensor platform field test. For this test, the buried sensor packages (marked by the blue flags) are located on the exterior of the antenna encircling the aluminum well casing.

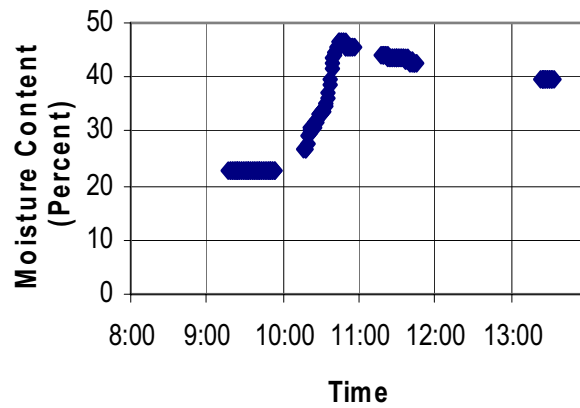

Figure 4. Volumetric water measurements recorded by INL Sensor Package #3 as water infiltrated into the soil. Sampling depth for this sensor package was 13 to 20 inches.

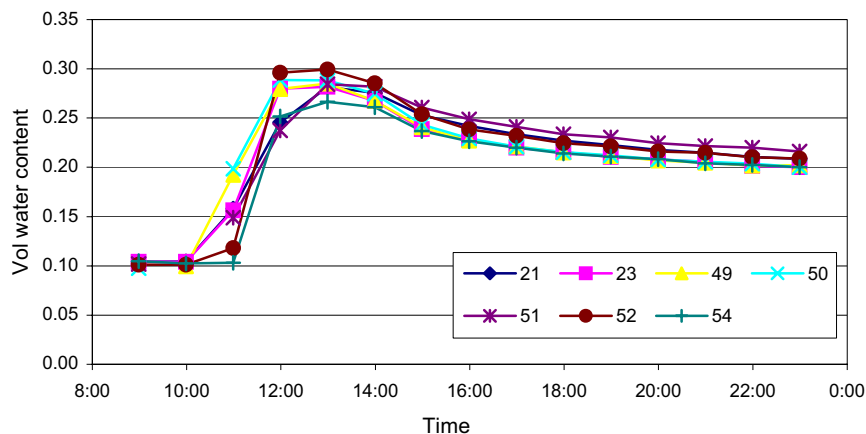

Figure 5. Volumetric water measurements recorded by NTS TDR sensors at a 1 ft. (TDR measurements provided by Charles Lohrstorfer and Alen Wittig, NTS.)

INEEL sensors. Cross talk between the two sensor types, TDR and INL platform, prevented their simultaneous use. The platform’s volumetric water sensor uses a calibration provided by the manufacturer that is not specific to each probe or the composition of the alluvium at the NTS. This resulted in absolute measurements that were different from those obtained from the TDR probes, but the INEEL sensor packages did duplicate the TDR’s response to the wetting front moving through the soil.

A second field test was performed with similar prototype sensor packages capable of monitoring volumetric water, temperature, and pressure. These packages were embedded in a barrier cap during construction at a superfund site in South Dakota. A year later, after construction was complete, the sensor packages were located and sensor data collected without any platform failures. Figure 6 shows a sensor package as it was being embedded and the barrier cap under construction.

After the field testing at NTS, a heat dissipation based matric water potential sensor was added to the sensor platform. To accomplish this task, the capabilities of the platform were extended to include two separate energy storage banks that could be individually charged and controlled. The primary storage bank is used to power the basic functionality of the platform and one or more low-power sensors such as temperature and volumetric water. The second storage bank is significantly larger (6.3 joules versus 0.003 joules) and is used to power the energy-intensive water potential measurement or other tasks that require extended power. This storage bank is software controlled and is only active when commanded. However, due to the size of the second bank, charge / measurement cycle times are significantly longer



Figure 6. INL wireless sensor platform field test at superfund site in South Dakota.

when activated, i.e. hours versus seconds for the primary bank alone. Figure 7 shows sensor packages with platforms having commercial volumetric water, water potential, and temperature sensors. To date, all sensors used with the platform have been commercial off-the-shelf technologies.^{2,3,4}

Calibration of the water potential sensor using a modified pressure plate extractor system engineered and build by NTS personnel is underway. Figure 8 shows the calibration system along with sensor data periodically collected at different system pressure settings. Two sensor packages are set vertically in the green plastic pipes attached to the lid of the pressure plate extractor. A small hoop resonant antenna is mounted above the pressure system. It is connected to a reader and laptop computer that controls data acquisition. The plastic pipes are used to allow the alternating magnetic field generated by the reader to couple with the sensor platforms encased within the pressure system. The system is programmed to periodically collect data

² Decagon Devices Inc., Pullman, WA, ECH₂O volumetric water sensor.

³ Campbell Scientific Inc., Logan, UT, 229-L matric water potential sensor.

⁴ Microchip Technology Inc., Chandler, AZ, TC1047AVNB temperature sensor.

from the two sensor packages at set time intervals. Upon completion of the calibration process, the sensors packages will be field tested at NTS.

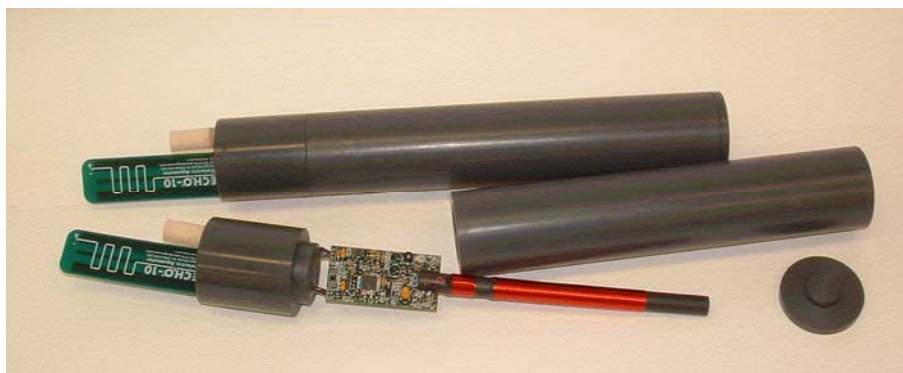

Figure 7. Sensor packages with INL platform and integrated volumetric water, water potential, and temperature sensors.

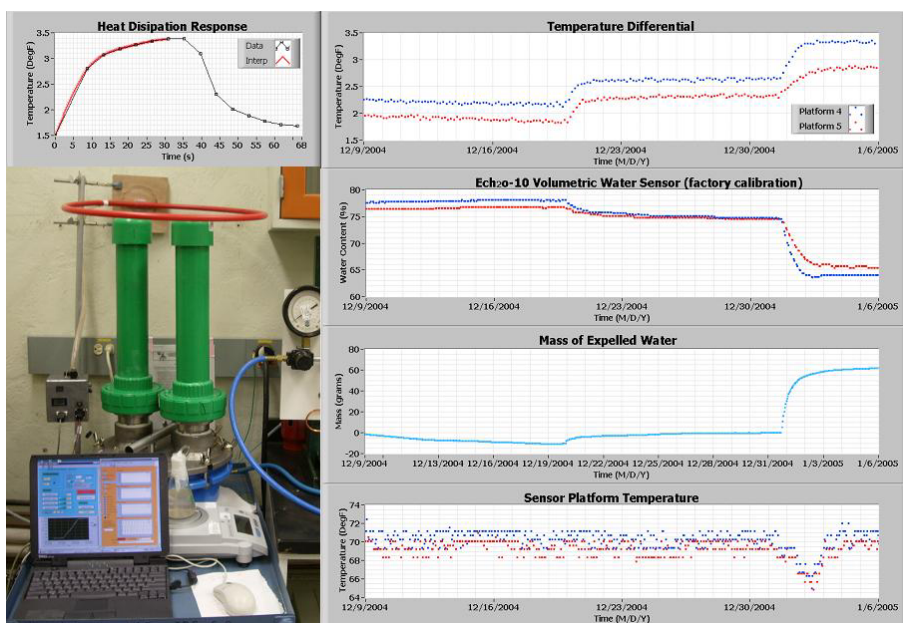

Figure 8. NTS-modified pressure plate extractor system used to calibrate the water potential sensors. The two green plastic tubes house two sensor packages during calibration as well as allow the alternating magnetic fields generated by the reader and sensor platform to pass through the pressure system boundary.

4. DISCUSSION/CONCLUSIONS

The INL sensor platform was developed to provide a method for long term subsurface sensing that does not require wires to penetrate the barriers. Due to the passive nature of the design, no maintenance needs to be performed and the low duty cycle provides the potential for a long service life. Service life will, in most cases, be defined by the service life of the sensors that directly interact with the environment or their ability to maintain calibration. Although the platform has been demonstrated to be fully functional, there are operational limits that define how the platform can be implemented.

Those limitations are:

1. A reader is required to be temporarily or permanently located on the surface to provide power and communications when measurements are made. An exception to this is possible if the platform is configured and programmed to use the large secondary energy storage bank to run low-power sensors for an extended period of time after the reader has been shut off or removed.
2. Operational depths are defined by the extent to which the resonant antennas on the reader and sensor platform can couple to transfer power and communicate. Laboratory and field testing at the INL indicates that the present system is limited to approximately 12 ft. Also note that the physical alignment of the antennas contribute to the efficiency of energy transfer, i.e. maximum efficiency is achieved when they are coaxial. Soil types and water content may also influence operational depths, but all testing to date suggests that the effects are small.
3. There is a trade off between operational depth and measurement cycle time. Increased working depths result in weaker magnetic field strengths and thus less energy transfer. As a result, it takes longer to charge the energy storage banks. At maximum operational depths, a platform with low-power sensors can be energized and read in seconds while it will take hours to charge the secondary energy storage bank for use with a high-power sensor such as the heat dissipation water potential sensor.

In conclusion, the INL sensor platform does provide a viable means for subsurface sensing when it is desirable not to penetrate structures with wires.

ACKNOWLEDGEMENTS

The Advanced Monitoring Systems Initiative (AMSI) provided support to INL for the design, development and testing of the moisture sensors. AMSI is an integrated DT&E project that aggressively searches for,

develops, tests, evaluates, and integrates promising new sensors and monitoring systems for end-user applications. AMSI is funded through the National Nuclear Security Administration's Nevada Site Office, and managed by Bechtel Nevada (BN).

AMSI also designed the required modification to the water content calibration system, funded the BN Engineering Department to complete design drawings and specifications, and the fabrication group to manufacture this innovative design. Work at INL was performed under DOE Idaho Operations Office Contract DE-AC07-05ID14517.

REFERENCES

- DOE-RL, 1999a, *200 Areas Remedial Investigation/Feasibility Study Implementation Plan – Environmental Restoration Program*, DOE/RL-98-28, Rev. 0, U.S. Department of Energy, Richland Operations Office, Richland, Washington.
- Kunerth, D. C., Svoboda, J. M. Slater, J. M. and Lee, J. E., "Monitoring Moisture Content In Surface Barriers Using A Passive Sensor Platform," INRA Subsurface Science Symposium, Idaho Falls, Idaho, Sept. 6-7, 2001.