

# **INL Capabilities For Nuclear Data Measurements Using The Argonne Intense Pulsed Neutron Source Facility**

## **International Workshop on Nuclear Data Needs for Generation IV Nuclear Energy Systems**

J.D. Cole  
M.W. Drigert  
R. Aryaeinejad  
D.W. Nigg  
R.V.F. Jannssens  
B.J. Micklich  
G. Terakopian

July 2005

This is a preprint of a paper intended for publication in a journal or proceedings. Since changes may not be made before publication, this preprint should not be cited or reproduced without permission of the author. This document was prepared as an account of work sponsored by an agency of the United States Government. Neither the United States Government nor any agency thereof, or any of their employees, makes any warranty, expressed or implied, or assumes any legal liability or responsibility for any third party's use, or the results of such use, of any information, apparatus, product or process disclosed in this report, or represents that its use by such third party would not infringe privately owned rights. The views expressed in this paper are not necessarily those of the United States Government or the sponsoring agency.

The INL is a  
U.S. Department of Energy  
National Laboratory  
operated by  
Battelle Energy Alliance



# INL CAPABILITIES FOR NUCLEAR DATA MEASUREMENTS USING THE ARGONNE INTENSE PULSED NEUTRON SOURCE FACILITY

J.D. COLE<sup>1</sup>, M.W. DRIGERT<sup>1</sup>, R. ARYAEINEJAD<sup>1</sup>, D.W. NIGG<sup>1</sup>, R.V.F. JANSSENS<sup>2</sup>, B.J. MICKLICH<sup>2</sup>, G. TER-AKOPIAN<sup>3</sup>

1. *Idaho National Laboratory, Idaho Falls, ID USA*
2. *Argonne National Laboratory, Chicago, Ill USA*
3. *Joint Institute for Nuclear Research, Dubna, Russia*

## 1.0 Introduction

The relevant facts concerning the Argonne National Laboratory – Intense Pulsed Neutron Source (ANL/IPNS) and the Idaho National Laboratory (INL) apparatus for use at the ANL/IPNS facility to measure differential neutron interaction cross sections of interest for advanced reactor physics applications are presented. The INL apparatus, which consists of an array of multiple types of multiple detectors operated in coincidence, signal electronics, and a data acquisition system, is presented as an application of new means and methods to measure the relevant parameters described. The immediate measurement goals involve measurement of neutron induced interaction cross sections for <sup>240</sup>Pu and <sup>242</sup>Pu with <sup>241</sup>Pu, <sup>241</sup>Am, with measurements for other nuclides of interest for advanced reactor physics applications to follow later. Specific uncertainties and error limits are presented and methods for controlling these uncertainties are described. The post experiment analysis using data sorts and data selection from a large, self-consistent data set to produce spectra that will be analyzed for direct results and used to determine cross sections is also discussed.

## 2.0 Neutronic Performance of the IPNS Facility

The ANL/IPNS facility is a spallation neutron source with a moderated neutron beam that has a neutron spectrum at 12 and 20 meters given in the Figure 1. The curves shown in Figure 1 are the results of average measured intensities and MCNP calculations performed at IPNS<sup>1</sup>. For perspective, a direct comparison of flux intensity can be made between IPNS and the Los Alamos Lujan Center at lower neutron energies where explicit numbers, in similar units, are available, in particular for epithermal neutrons. A measurement of the neutron spectrum at IPNS was performed and the epithermal neutron flux was determined using activation of a gold foil<sup>2</sup>. The value obtained for the epithermal angular current per unit energy at 1.0-eV, for the “F” moderator is  $2.91 \times 10^{10}$  n/sr- $\mu$ A-sec-eV. Converting this expression to comparable units results in an IPNS flux at epithermal energies of approximately 0.005 n/sr/proton/eV. Recent papers<sup>3,4</sup> have reported neutron spectra at the Lujan Center for several beam lines. The reported neutron intensities at 1eV range from 0.001 to 0.005 n/sr/proton/eV. For the Lujan flight path FP14, the corresponding number is 0.001 n/sr/proton/eV. Moreover, the proton current for IPNS is 15  $\mu$ A, while that at Lujan is 100  $\mu$ A. Consequently, the two facilities are very nearly the same in the epithermal range. Both LANSCE and IPNS are spallation sources that produce around 20 and 9 neutrons respectively for every proton that strikes a nucleus in the target. The plot shown in Figure 1 also provides the referenced spectral information for Lujan.

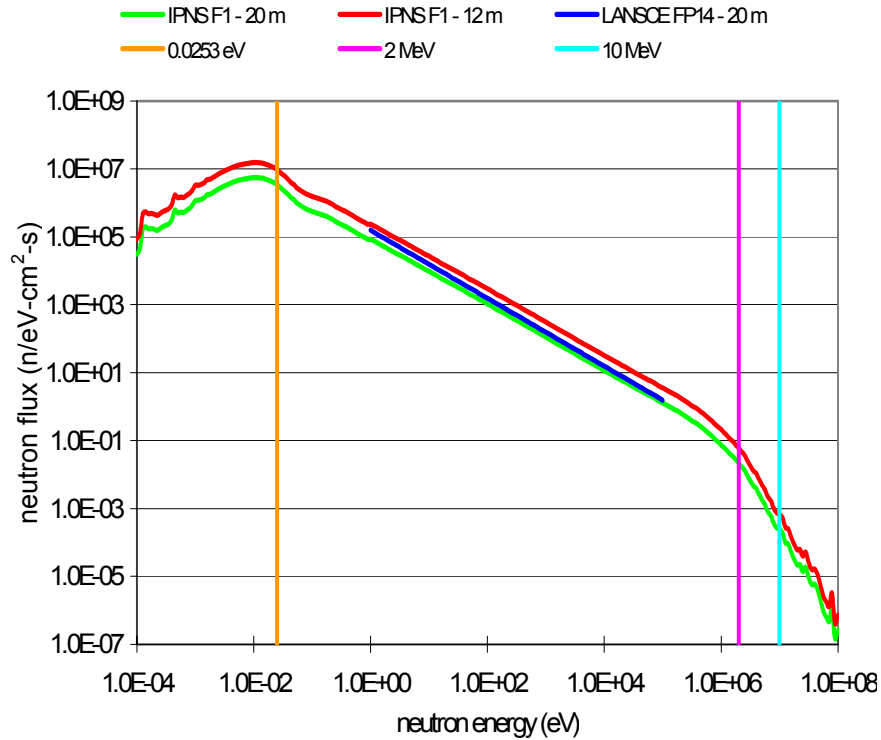

**Figure 1 Plot of the neutron spectrum on the F3 beam line used for the INEEL apparatus for distances of 12 and 20 meters and the extrapolated values for FP14<sup>3,4</sup> at LANSCE.**

This flux information is used in our calculation of expected event rates, design evaluation, and other efforts to configure the experimental apparatus. In general the neutrons of energy below 0.001 eV and above 10 MeV are of low enough intensity to be neglected in the experiment and are of little interest in fission reactor applications in any event. The low-energy neutrons can also be filtered with a cadmium absorber to remove the neutrons below 0.4 eV if desired. The integrated intensity as flux (neutrons/cm<sup>2</sup> s) is given in Table 1. Table 1 values are the actual flux values at the target location as used in the experiment.

Table 1. Integrated neutron flux for the F-moderator beam lines for 12 and 20 meters. (neutrons/cm <sup>2</sup> s)					
F1		F2		F3	
12 m	20 m	12 m	20 m	12 m	20 m
3.73E+08	1.34E+08	3.99E+08	1.44E+08	3.73E+08	1.34E+08

The uncertainty of the energy of a neutron that induces an interaction of interest in the target is determined largely by the uncertainty on the n-TOF from the time width of the proton pulse. In addition to this important parameter, the pulse rate and the flight path length interact to limit the useable energy range of the neutrons. At IPNS the pulse rate is 30 Hz and the proton pulse full width is 70 ns<sup>5</sup>.

Table 2. n-TOF and error for selected neutron energies and two flight path lengths at IPNS F3				
neutron energy (eV)	Flight path length			
	12 m		20 m	
	flight time ( $\mu$ s)	pulse width error	flight time ( $\mu$ s)	pulse width error
0.001	2.74E+04	0.17%	4.57E+04	0.10%
0.01	8.67E+03	0.17%	1.45E+04	0.10%
0.1	2.74E+03	0.17%	4.57E+03	0.10%
1	8.67E+02	0.17%	1.45E+03	0.10%
5	3.88E+02	0.17%	6.47E+02	0.10%
10	2.74E+02	0.17%	4.57E+02	0.10%
50	1.23E+02	0.18%	2.04E+02	0.11%
100	8.67E+01	0.19%	1.45E+02	0.11%
500	3.88E+01	0.25%	6.47E+01	0.15%
1000	2.74E+01	0.30%	4.57E+01	0.18%
5000	1.23E+01	0.59%	2.04E+01	0.36%
10,000	8.67E+00	0.82%	1.45E+01	0.49%
50,000	3.88E+00	1.81%	6.47E+00	1.09%
100,000	2.74E+00	2.56%	4.57E+00	1.53%
500,000	1.23E+00	5.71%	2.04E+00	3.43%
1,000,000	8.67E-01	8.07%	1.45E+00	4.84%
2,000,000	6.13E-01	11.41%	1.02E+00	6.85%
5,000,000	3.88E-01	18.05%	6.47E-01	10.83%
7,000,000	3.28E-01	21.35%	5.46E-01	12.81%
8,000,000	3.07E-01	22.83%	5.11E-01	13.70%
10,000,000	2.74E-01	25.52%	4.57E-01	15.31%

All beam lines at IPNS are heavily shielded and evacuated so that backgrounds are reduced. The low background at IPNS is an important factor for the long runs needed for high statistic experiments.

### 3.0 The INL Program

The INL apparatus was originally installed at IPNS to perform experiments using induced fission of actinide targets for prompt information concerning fission yields by isotope pairs, nuclear structure information for prompt de-excitation of the fission products, multiplicity of both neutron and gamma rays by isotope pairs, and isotope pair distributions for fission cluster models. These efforts are extensions of spontaneous fission studies on  $^{252}\text{Cf}$  and  $^{242}\text{Pu}$  conducted with arrays of HPGe detectors at INL, Oak Ridge National Laboratory (ORNL), Lawrence Berkeley National Laboratory (LBNL), and finally on GAMMASPHERE at both ANL and LBNL. This work has produced over 100 publications on the nuclear structure of fission products prior to beta decay, fission yields by isotope pairs, and explicit neutron multiplicity as correlated to specific fission pairs.

Two years ago efforts began to modify the INL apparatus at IPNS to provide the capability to measure neutron interaction cross sections (fission [n,f], capture [n, $\gamma$ ], and inelastic neutron scattering [n,n']) as a function of incident neutron energy, branching ratios for the production of different isotopes by neutron capture or fission, and cross sections for the production of independent yields from actinide fission. All of the work is for actinides, to be produced and burned in a new generation of reactors being developed by the United States – Department of Energy (DOE). Some of these reactors are to have harder or higher energy neutron spectra than the current generation of thermal reactors, with much higher anticipated burnup, making the various transuranics of significantly greater importance than has been the case previously.

The goal of the work is to produce results that have statistical uncertainties of 3% -5% or less and maximum neutron TOF uncertainties of 10%. In the resonance energy range of a few eV to ~100 keV the TOF uncertainties are much smaller, ranging from 0.2% to ~2% for both fission and capture cross sections.

The INEEL apparatus for measuring event spectra for actinide targets of interest at IPNS is composed of an array of detectors of multiple types and multiple numbers of each type. There is a data acquisition system based on VME architecture with standard NIM and CAMAC electronics to acquire data on an event-by-event basis and store it in list mode for later analysis. A separate computer system is used for a multi-stop Time-to-Digital Converter (TDC) to acquire a neutron TOF spectrum from a fission chamber with high purity  $^{235}\text{U}$  foils. The fission chamber consists of six thin  $^{235}\text{U}$  foils arranged in a ring surrounding the volume that the neutron beam passes on its way to the experiment target position. Key features of the apparatus and experimental procedures are described in the following sections.

**3.1 Online Neutron Flux Measurement.** The fission chamber and associated TDC are used to determine the incident neutron spectrum from the IPNS neutron production target in the same IPNS beam line as the primary detector array and as a real-time neutron flux monitor. This is a continuous measurement, as IPNS is an accelerator driven facility and over long run times the intensity of the neutron flux varies. The direct neutron spectrum is determined using the ENDF  $^{235}\text{U}$  fission cross section. It is possible to report results based on a ratio of the observed neutron event spectrum from the actinide target in the main array and the neutron event spectrum of the fission chamber. For both the incident neutron flux determination and the neutron event spectrum from the fission chamber, the error from the  $^{235}\text{U}$  cross section, which ranges from 3% to 5% itself, must be included in the final uncertainty. This is combined with our experimental error as a standard square root of the sum of the squares of the independent error. The statistical error from the fission chamber is less than 1% over the TOF ranges as this fission chamber has higher neutron event rate due to the higher fission chamber efficiency than the multi-detector array.

The timing pulses, both start and stops, are generated from a leading edge discriminator set such that the walk or jitter of the start pulse, the  $t_0$  from the accelerator, and of the stops, the pulse from the fission chamber, have the same level and electronic walk. A calibration pulse from the gamma ray flash produced in the neutron-generating target is fed into the TOF spectrum to provide an absolute calibration. The differential linearity of the TDC is  $<\pm 1\%$  full range. The resolution in time of each bin can be set to 1 ns and the total number of bins set a 33,000,000 to cover the total time interval between pulses. The important point is that the 33 millisecond time between pulses, i.e. the entire neutron energy range of interest, can be covered in the experiment in one measurement. It is not required to make separate measurements covering only a small time range or use very coarse resolution to cover the energy range in the time interval and then match the independent measurements together. The primary uncertainty in the TOF is determined by the proton pulse width at energies above a few eV, and since data are collected on an event-by-event basis, the uncertainty due to detectors, electronics or cabling can be corrected in software.

This equipment and method allows a model-independent measurement of the neutron interaction cross section to be made over a continuous energy range from a few meV to above 2 MeV without breaking the measurement into different energy sections with a time resolution as given in Table 2, and the neutron event spectrum uncertainty determined primarily by statistics. With approximately 4000 hours of beam time available for measurements in one year, low statistical error is easily achieved where as continuous and long runs at other facilities are not as readily possible.

The integrated neutron flux from the fission chamber is fed into a VME scalar module that is periodically readout by the main data acquisition system and the results are injected into the recorded event stream. This way the incident neutron flux is monitored throughout the course of the cross section measurement. The overall system dead time is determined by comparing the number of master event triggers generated by the front-end electronics with the number of events processed by the data acquisition system. These numbers are recorded in the data acquisition log as well as a periodically updated process monitor file. This monitor file also contains information of various error conditions seen by the data acquisition software. These include bad event rates for the different detectors that make up the measurement system.

**3.2 Neutron Event Spectrum Determination.** A second multi-stop TDC is used obtain the neutron TOF for the neutrons observed in the main array. The multi-stop TDC produces a TOF for each neutron event, a trigger, during the 33-millisecond interval between proton pulses. One or more of the triggers, discussed

below, are used as a stop for this second TDC. The TDC has user selectable time bins with a total number of bins of  $2^{32}$  with the minimum time per bin being 1 nanosecond. A spectrum containing 30,000,000, 1-nanosec bins would allow maximum coverage of the time interval and the minimum time per bin. In actual use a smaller number is used depending on the energy resolution for the spectrum that is desired and what energy range of incident neutrons is of interest. The point is that the time bins can be set such that they have minimum impact on the energy resolution and the proton pulse width is still the dominant source of error.

Although the time bins can be summed at a later point, the content of these bins, which represents the number of events observed in that time interval, provide the basis of the statistical accuracy for determining the incident neutron event intensity at each point. Where as this spectrum can have several million channels, the determination of the flux spectrum requires only a few thousand points. The condition to be met in the experiment is that this statistical error for each of the compressed spectrum bins is 3-5%. This means that each compressed bin must have on the close order of 1000 counts or more above background. This gives a total event number of  $\sim 50,000,000$  for a 50,000 channel spectrum. This is not a difficult number to obtain with the INL equipment and our goal for any actinide target is  $\sim 1,000,000,000$  events.

**3.3 The Detector Array.** The INL array is composed of 12 Compton suppressed, high purity germanium (CSHPGe) detectors, eight fast neutron detectors (BC501 liquid scintillator), and a stack of 32 Silicon (Si) detectors interleaved with double-sided foils of actinide targets. The trigger electronics starts the digitization process if: two of the CSHPGe; or two neutron detectors; or a CSHPGe and a neutron detector produce a signal within a set coincidence time window. In this way three separate conditions can be used as independent triggers (T1, T2, and T3 respectively) for determining a neutron interaction has occurred in a target. The coincidence is overlap timing with a time window of 50 to 100 nanoseconds.

The 32 Si detectors are used to directly detect the fission fragments as these fragments recoil directly into the Si detectors. The Si detectors and the target foils are interleaved, each actinide foil has a selected thickness that will allow the low energy, light mass fission fragment to escape the target and enter the Si detector, which is in contact with the target material. A discriminator is used to reject  $\alpha$ -particles and their pileup signal and accept only the fission fragment signal, which is a factor of ten greater in amplitude. These fission fragment signals in the Si detectors are used as the fourth trigger (T4) in the system. Si detectors are used instead of a fission chamber primarily because the rise time of the output pulse is faster by roughly a factor of ten. In addition, since the Si detector is in contact with the actinide target, gamma rays observed from the fragment have no Doppler shift or broadening due to emission in flight. There are other advantages with size, less support electronics, better  $\alpha$ -particle discrimination, and low mass material. The energy output of each Si detector is also digitized and included in the data packet.

Figure 2 presents a drawing of a double detector unit on the left and the right shows an assembly of four double detector units. These Si detectors have been made and tested with  $^{252}\text{Cf}$  sources. A paper is in preparation but relevant results are that operation has been tested with  $\alpha$ -particle doses of greater than  $10^{12}$   $\alpha/\text{cm}^2$  and fission fragment doses of greater than  $10^{10}$  fragments/ $\text{cm}^2$  without deterioration of signal and a rise of leakage current increase of less than a factor of ten. The testing of these detectors continues to determine the failure limits but already these numbers indicate that the detectors will survive beyond our experimental statistical goal. Further tests with  $^{239}\text{Pu}$  targets and a Si detector stack are currently underway.

The four triggers T1, T2, T3, and T4 are “OR’ed” logically to produce an event signal. This event signal will be used to trigger data acquisition of digitized detector signals, time relationships between the detector signals, and as a stop on a multi-stop TDC as described above. In this way a multi-parameter data packet is acquired, for each radiation event detected and stored in list mode format. Since the system is configured to respond to coincidence events and the prompt timing of an event is from  $10^{-22}$  seconds to  $10^{-12}$  seconds, a single trigger can result in multiple radiation types being included in the event. The simplest example is that of a fission fragment being detected in a Si detector, a T4 event, and single gamma ray or neutron radiation also observed. Consider the following examples of events and what they mean.

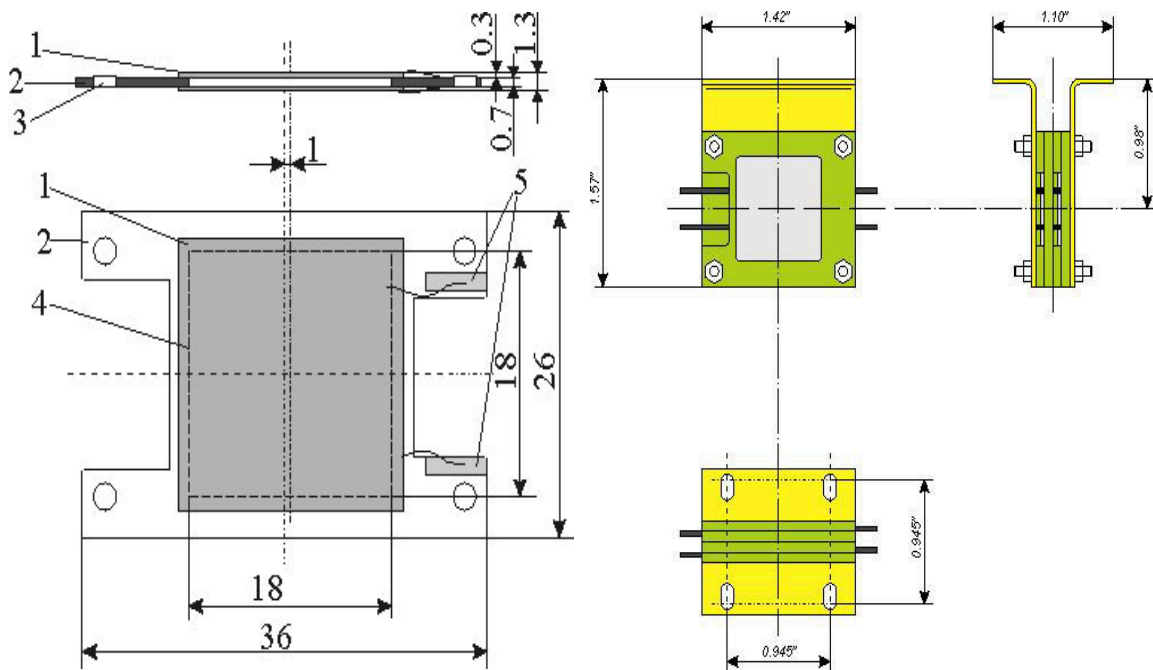

**Figure 2** The left side shows a pair of Si detectors mounted onto a frame. 1 is the Si detector, 2 the Al frame, 3 the alignment bushing, 4 the hole in the frame, and 5 the detector contacts. The other numbers are the dimensions in millimeters. The right shows a stack of four detector units (two detectors each) with interleaved target foils assembled on a mounting frame for placement in the beam. The current plan would use 16 frames of 32 detectors and interleaved target foils.

**3.3.1 Gamma rays alone.** Two or more gamma rays observed in two or more CSHPGe detectors within the time window will result in a valid T1 trigger. If no other triggers are present, this event would be acquired as a simple gamma-ray coincidence that could arise from beta decay of a fission fragment, a neutron capture event, or an inelastic scatter.

**3.3.2 Neutrons alone.** A coincidence pair in the neutron detectors (T2) can be caused by a gamma ray observed in a neutron detector and a scattered neutron. The neutrons and gamma rays in the liquid scintillator detectors are distinguished by pulse shape discrimination in post analysis. This type of event can be due to inelastic scattering of the neutron or simply two coincident gamma rays being seen in the neutron detectors. For this to be a valid event that can be used in post analysis, two neutrons must be observed with a Si detector fission fragment. In other words a T2 must be present with a T4 to be processed in analysis. A usable elastic scatter event needs to be a T3 with the gamma ray observed in a CSHPGe detector.

**3.3.3 Neutrons and gamma rays together.** This is a T3 event but it can be valid without a T4 Si detector signal. For an inelastic event discussed above, it is only used if the gamma ray is observed in a CSHPGe detector. If multiple neutron detectors and CSHPGe detectors are present as a coincidence event, this is valid only if a Si detector also “sees” a fission fragment.

**3.3.4 Si Detector Triggers – T4.** With the Si detectors and the actinide target material in contact, fission fragments cannot escape the target foils without being observed in a Si detector. This condition is the critical signature for a fission event. A fission event is a high multiplicity event and can result in one or more neutrons or gamma rays being detected in the appropriate detectors. This high multiplicity event has special significance.

*3.3.5 Si detectors with other detector present.* This is the special case that shows the particular power of the INL apparatus at IPNS. These types of events allow particular information to be gained that is needed in reactor programs. To measure a simple fission cross section requires only a detector to detect the fission fragment and an MCA to store a neutron event spectrum. A neutron capture cross section can be done with a detector like DANCE<sup>6</sup> if no branching ratio is desired or no competing reaction channel is present. But if other parameters are desired, additional experiments are needed or different methods must be used. As an example consider the need to measure neutron and gamma ray multiplicities. The method to use arrays of detectors operating in coincidence has been carefully explored<sup>7,8</sup> and the multiplicities of the radiations can be determined. The methods work for mixed types of detectors as well as arrays of single types.

With the ability to select the events by post experiment sorting the multiplicities of both neutrons and gamma rays can be determined. The production rates of the selected gamma rays arising from the prompt fission fragments or the excited isotopes produced by neutron capture are used to determine the appropriate reaction cross sections as a function of the incident neutron energy, determined from the event-by-event neutron TOF parameter.

In addition to information required to extract absolute reaction cross sections, the acquired data sets also will contain the information needed to extract independent fission fragment yields<sup>9</sup> that can be used to validate accepted values in a model independent manner.

The most important aspect of this powerful ability to select events by sorting and then determine cross sections is to reduce background and events unassociated with the reaction channel of interest. This reduces the error on the cross section by allowing an event set to be selected that only contains events that are from that particular reaction channel. When various cross sections are measured conventionally, a main problem is to select an experimental configuration that will allow radiations from unassociated channels to be reduced. This is the effort in using C<sub>6</sub>D<sub>6</sub> detectors to measure neutron capture cross sections on actinides yet discriminate against radiations from fission. The selection of particular events from a data set allows particularly low uncertainty results to be obtained.

This also allows the measurement of branching ratios of reaction channels to be determined from the larger data set. In addition, it also can allow otherwise impossible cross sections and branching ratios to be determined. Consider the example, neutron capture for <sup>241</sup>Am to <sup>242</sup>Am and <sup>242m</sup>Am.

For various systems it is important to know the branching ratio or partial cross section for neutron capture of <sup>241</sup>Am to <sup>242</sup>Am or <sup>242m</sup>Am, thus what is the production ratio of <sup>242</sup>Am:<sup>242m</sup>Am? This is a difficult measurement to perform. For the INEEL apparatus this can be done by selecting the events of capture from fission (no Si detector events), and then sorting for particular gamma rays that cascade from the same level to the isomeric 5<sup>-</sup> level and to the 1<sup>-</sup> ground state. In point of fact, it is really necessary to measure multi gamma ray cascades to these two levels to determine the population ratios. This is something that is best done with arrays of CSHPGe detectors (consider Gammasphere or Euroball).

The problems of measuring the fission cross section for material with high spontaneous fission rates, or spontaneous fission rates that are statistically significant, is again a problem handled by sorting events based on different conditions. This method also reduces the total error whereas the traditional method of beam-on, beam-off does not remove the spontaneous fission events from the beam on data set. Selecting fission events by requiring a Si detector signal, and then sorting on gamma rays from different fission pairs will provide information on contributions for the two types of fission processes. The distribution of neutrons and thus associated fragments pairs are different for the spontaneous versus induced fission. This is caused by the differences in the excitation energy of the fissioning nucleus. In spontaneous fission the nucleus is in its ground state. For induced fission the nucleus will be at an excited state due to the energy brought in by the incident neutron and by the rearrangement of the population of the nuclear orbitals in the nuclear system after the neutron is captured. In the case of <sup>240</sup>Pu which is very important for the reactor programs, separate spontaneous and induced fission measurements are planned. A <sup>240</sup>Pu sample has been obtained which will be used to directly measure the spontaneous fission. The induced fission will be measured using a <sup>239</sup>Pu target that will be obtained from Russia.



**3.4 Two Unique Capabilities.** The above discussion provides a description of the unique capabilities of the INL apparatus and how the IPNS facility supports these capabilities. The most important is the ability to take coincidence data associated with a particular nuclear event. An array of detectors can be operated in this manner at other facilities but at IPNS two features are important: 1) an intense flux of neutrons, and 2) the availability of the beam for long experimental measurements. These two facts allow the high statistics data needed to be acquired. To achieve the goal of  $\sim 10^9$  events to be stored by the data system, requires over 100 days of beam time. This long experimental time is available at IPNS as the INL apparatus is on one beam line and not affecting experiments at other locations in the facility. These exceptionally high statistics are the key factor in reducing the statistical error to the 3-5% range.

The other unique feature is due to the nuclear event based data collection and post analysis by sorting data into subsets based on physics conditions. This very approach cannot be done without the high statistical data set described. By imposing multiple conditions and sorts via software or computer processing in selecting data sets for detailed analysis, the “cross talk” between channels can be minimized in ways that are not possible in the hardware of the electronics. The simplest and easiest to understand is the Si detector trigger T4 to separate fission events and all other events. The non-fission events can be further sorted look at other reaction channels. This capability has produced exceptional results in nuclear structure and spontaneous fission studies and is easily applied to the problems of measuring various neutron cross sections of actinide isotopes.

This post analysis capability based on data selection of reaction channels provides results that are self-consistent across the larger experimental data set. This means that the ability to use different approaches in sorting can provide results that provide consistency checks that are otherwise not available. An example of this is the case of the determination of a fission cross section by direct selection of the observation from the Si detectors and the cross section determined from sorting on gamma rays from the highest yield fission fragments. Although the statistics in these two subsets of data will be different, the cross section should have the same result in both cases. This is a powerful tool to check the results and provide a consistency not in previous work.

**3.5 Actinide Targets.** Our targets are fabricated in Russia by our collaborators at the Joint Institute for Nuclear Research (JINR) and they have material in usable quantities up through the light californium isotopes. The targets are metal foils, not oxides, on an appropriate backing and of the thickness needed to allow the light fission fragments to escape the target and enter a silicon detector that is in contact with the target material. This removes the need for large corrections of the incident neutron flux that must be done in the case of oxide targets. This removes an additional source of error. In addition, the vapoe deposition of metal onto metal backing gives excellent stability to the targets and reduces the risk of contamination due to targets coming off the backing. The isotopic purity of the targets is greater than 98% for the principal isotope and a detailed chemical analysis is provide for each target batch and individual target characteristics such as mass per unit area, total mass, and other are provided. The targets are delivered to us in a ready to use form that we request such that no preparation other than mounting them in the Si detector stack is required.

## 4.0 Conclusions

The description of the INL apparatus has focused on operational procedures and how errors are minimized through techniques new to cross section measurements but well established in low energy nuclear physics. These are not simply methods of instrumentation but also of computer processing and data analysis.

Neutron TOF errors and uncertainties are dominated by the moderated neutron pulse width and the width of the delivered proton pulse width, but software corrections of measured electronic and detector response times allow their contribution to be less than 10% of the total error.

The fact that long run times are possible at IPNS without impacting the operation of the rest of the facility, means that the statistical errors, which dominate the total error, can be minimized to reach our goal of less than 3% to 5% over the neutron event spectrum. The error introduced from using  $^{235}\text{U}$  as a standard is what is quoted in the ENDF database and cannot be changed at this time. Some consideration is being given to

using  $^3\text{He}$  tubes instead of a fission chamber, but we are going to continue to use the fission chamber for now. The  $^3\text{He}$  tubes would allow the use of a simple  $1/v$  relation for a standard.

The goal is absolute cross section values but, as has been done in the past, a relative neutron cross section can be normalized to a single point, i.e., a previous thermal-neutron value. These existing thermal values from past years provide a check on the work as the cross sections being measured include the thermal value.

## 5.0 References

- 1 Private communication, B.J. Micklich, ANL.
- 2 J.M. Carpenter, *et al.*, Nucl. Instr. and Meth. A234 (1985) 542-551.
- 3 Muhrer, G.; *et al.*, Nucl. Instr. and Meth. A 527 (2004) 531-542.
- 4 Takashi Ino; *et al.*, Nucl. Instr. and Meth. A 525 (2004) 496-510.
- 5 "IPNS Progress Report" 1996-2001.
- 6 Heil, M.; *et al.*, Nucl. Instr. and Meth. A 459 (2001) 229-246.
- 7 Werf, S.Y. van der, Nucl. Instr. Meth. A153 (1978) 221-228.
- 8 Ockles, W.J., Thesis, University of Groningen, The Netherlands (1978); Z. Phys. A286 (1978) 181-185.
- 9 Ter-Akopian, g.M.; *et al.*, Phy. Rev. C 55 (1997) 1146-1161.