

CRWMS/M&O

Calculation Cover Sheet

Complete only applicable items.

1. QA: L

Page: 1 Of: 19

2. Calculation Title Volumes, Masses, and Surface Areas for Shippingport LWBR Spent Nuclear Fuel in a DOE SNF Canister			
3. Document Identifier (including Revision Number) BBA000000-01717-0210-00056 REV 00			4. Total Pages 19
5. Total Attachments 3		6. Attachment Numbers - Number of pages in each I-12; II-1; III-1.	
	Print Name	Signature	Date
7. Originator	Guy E. Ragan	<i>Guy E. Ragan</i>	10/20/1999
8. Checker	Amir S. Mobasheran	<i>Amir S. Mobasheran</i>	10/21/99
9. Lead	J. Wesley Davis	<i>J. Wesley Davis</i>	10/22/99
10. Remarks This document was prepared under QAP-3-15 and was in the checking process prior to the effective date of AP-3.12Q. However, AP-3.12Q, Section 2.0, allows the document to be completed under the previous implementing procedure.			
Revision History			
11. Revision No.	12. Description of Revision		
00	Initial issue.		

CONTENTS

	Page
1. PURPOSE.....	4
2. METHOD	4
3. ASSUMPTIONS.....	5
3.1 ASSUMPTIONS RELATED TO THE SNF CANISTER.....	5
3.2 ASSUMPTIONS RELATED TO THE SNF RODS	7
3.3 ASSUMPTIONS RELATED TO THE SNF ASSEMBLIES.....	8
4. USE OF COMPUTER SOFTWARE AND MODELS	10
4.1 SOFTWARE APPROVED FOR QA WORK	10
4.2 SOFTWARE ROUTINES	10
4.3 MODELS	10
5. CALCULATION	11
5.1 ELEMENTARY FORMULAS FOR VOLUME AND SURFACE AREA	11
5.2 DERIVATION OF A VOLUME FORMULA FOR FUEL PELLETS.....	12
5.3 DERIVATION OF A SURFACE-AREA FORMULA FOR FUEL PELLETS.....	13
6. RESULTS	16
7. REFERENCES	18
8. ATTACHMENTS.....	19

FIGURES

	Page
5-1. Cutaway View of a Fuel Pellet Showing One of the End Dishes and Naming Key Dimensions	15

TABLES

	Page
5-1. Elementary Formulas for Volume and Surface Area.....	11
6-1. Selected Results.....	17
8-1. List of Attachments	19

1. PURPOSE

The purpose of this calculation is to estimate volumes, masses, and surface areas associated with (a) an empty Department of Energy (DOE) 18-inch diameter, 15-ft long spent nuclear fuel (SNF) canister, (b) an empty DOE 24-inch diameter, 15-ft long SNF canister, (c) Shippingport Light Water Breeder Reactor (LWBR) SNF, and (d) the internal basket structure for the 18-in. canister that has been designed specifically to accommodate Seed fuel from the Shippingport LWBR. Estimates of volumes, masses, and surface areas are needed as input to structural, thermal, geochemical, nuclear criticality, and radiation shielding calculations to ensure the viability of the proposed disposal configuration.

2. METHOD

The volume and surface area calculations are performed primarily by applying basic formulas of geometry to the nominal dimensions of the objects considered. Masses are calculated as volume times density. Due to chamfered or tapered and dished ends in the otherwise cylindrical fuel pellets, basic formulas are inadequate for calculating the volume and surface area of the fuel pellets. Special formulas for calculating surface areas and volumes of the fuel pellets are derived in Sections 5.2 and 5.3.

3. ASSUMPTIONS

All of the assumptions are used in Section 5.

3.1 ASSUMPTIONS RELATED TO THE SNF CANISTER

The assumptions in this section are used in the tab labeled “SNF Can” in the Excel workbook cited in Section 5.

- 3.1.1 The dished heads of the SNF canisters are assumed flat and the hole in the middle and the end plug are ignored. That is, the head is treated as a flat disk. The basis of this assumption is the observation that because the heads are small compared to the rest of the canister, the radius of curvature of the dished heads is large compared to the diameter of the canister, and the hole and the end plug are small, the induced errors are negligible.
- 3.1.2 The impact plates in the 18-inch SNF canisters have rounded tapers on the outside surfaces to allow them to be cradled by the dished heads. The tapers are ignored, as well as the grooves in the surface and the hole through the middle. That is, the plates are approximated as cylindrical disks of the same radius and central thickness as the actual plates. The basis of this assumption is the observation that because the impact plates are small compared to the rest of the canister and the added volume and surface area are small compared to the volume and surface area of the impact plates, the induced errors are negligible.
- 3.1.3 A backing ring provides for secure placement of the end piece before the canister is welded shut. The backing ring has an angular cut at one end, which is ignored for the volume calculation. That is, the maximum height of the ring is used for the volume calculation. The basis of this assumption is the observation that because the backing ring is small compared to the rest of the canister and the added volume is small compared to the volume of the backing ring, the induced error is negligible.
- 3.1.4 The interior surface area calculation entirely ignores the backing ring. Because the backing ring covers nearly as much surface area as it adds, this approximation essentially amounts to ignoring only the end surfaces of the backing ring. The basis of this assumption is the observation that because the end surfaces of the backing ring are very small compared to the interior surface area of the canister, the induced error is negligible.
- 3.1.5 The calculation of the interior volume of the canister ignores the backing ring. The basis of this assumption is the observation that because the volume of the backing ring is very small compared to the interior volume of the canister, the induced error is negligible.

- 3.1.6 The exterior surface area calculations ignore the annular end surfaces of the 18-in. and 24-in. diameter shells. The basis of this assumption is as follows. Because the combined surface area of the annular ends of each canister is very small compared to the exterior surface area of the canister, the induced errors are negligible in each case.
- 3.1.7 The exterior surface area calculation ignores the inner surfaces of the lifting rings parallel to the axis of the canister. The basis of this assumption is the observation that, because the area of the inner surfaces is very small compared to the exterior surface area of the canister, the induced error is negligible.
- 3.1.8 The mass of filler material that may be used to fill the otherwise empty spaces in the canister is calculated based on the assumption that the filler will be aluminum shot with a bulk density of 75 percent of 2.7 g/cm^3 , which is the approximate theoretical density of aluminum metal and an assortment of aluminum alloys (Ref. 7.1, pp. 53-66). A sample of aluminum shot was obtained and examined for the purposes of this calculation. The sample consisted of granules of aluminum of irregular shape and size. The manufacturer declined to provide documentation of the bulk density or solid fraction of the aluminum shot. For uniform spheres, tests have shown that solid fractions in the neighborhood of 60-62 percent can be expected (Ref. 7.2, p. 8). However, a mixture of particles of various sizes can achieve higher packing densities. For example, a mixture of two sizes of particles that separately pack with a solid fraction of 62 percent can achieve a solid fraction of $(0.62 + 0.62 - 0.62^2) = 86$ percent when mixed together (Ref. 7.3, pp. 18-20). Such dense packing requires a great disparity in particle sizes (approaching a factor of 7 and above), so that the smaller particles can fit into the interstices between the larger ones (Ref. 7.3, pp. 20-21). Visual examination indicated that such large size disparities are not present in the sample that was obtained for this calculation. Moreover, departures from spherical shape tend to reduce the packing density (Ref 7.3, pp. 17-18). Therefore, high solid fractions approaching 75 percent are not expected with aluminum shot similar to that represented by the sample that was examined. The basis of this assumption is the observation that if a solids fraction of 75 percent is assumed, the calculated mass will exceed the mass that would be experienced in practice and the higher mass will be conservative from a structural perspective. The higher mass is not likely to be conservative from a shielding or criticality perspective.
- 3.1.9 The volume of filler material displaced by a Seed assembly is calculated as the displacement of the hexagonal prism outlined by the Zircaloy-4 support shell surrounding the rest of the assembly. In fact, the bottom cover plate is open and hollow and would likely capture some filler material. Also, the shipping plate at the top is open in the center and might allow some filler material to flow into the space above the top base plate. The basis of this assumption is the observation that the volumes in question are small compared to the total volume of the assembly, so the induced error is negligible.

- 3.1.10 The filler material is assumed to be excluded from the empty space between the Seed fuel rods. The bases of this assumption are the observations that (a) the hexagonal shell surrounding the fuel rods and the hardware on the tops and bottoms of the fuel assemblies restrict flow, and (b) the nominal diameter of the aluminum shot being considered as filler material (3 mm) is greater than the minimum distance between adjacent Seed fuel rods (1.6 mm).
- 3.1.11 Blanket assemblies have an empty center where the Seed assemblies fit during reactor operation. The volume of filler that would be displaced by a Blanket assembly is calculated to allow for two mutually exclusive possibilities. In one case, the guide tube is plugged so that filler is excluded, and the filler is assumed too coarse to flow into the spaces between adjacent rods. In the other case, filler occupies the guide tube and the spaces between adjacent rods. The Type III Blanket assemblies are assumed because they have the greatest mass. The basis for these assumptions is that these two possibilities give the minimum and maximum volumes of shot that a canister containing a Type III Blanket assembly could accommodate.
- 3.1.12 The surface area calculation for the basket assembly in the 18-in. canister uses the inner widths of the plates, which are slightly greater than the outer widths, and ignores the edges of the plates and the surfaces covered due to intersections between plates. The basis of this assumption is the observation that the small error resulting from using the inner widths roughly compensates for the small error induced by ignoring the edges and covered surfaces in the intersections between plates.
- 3.1.13 For calculating the loaded mass of the SNF canisters, the maximum reported masses for Seed, Blanket, or Reflector assemblies (Ref. 7.4, Table 3-4) are used, rather than the masses calculated in the Excel workbook. The basis of this assumption is the fact that the reported masses are direct measurements and are, therefore, likely to be more accurate than the calculations performed here.

3.2 ASSUMPTIONS RELATED TO THE SNF RODS

The assumptions in this section are used in the tab labeled "Rods" in the Excel workbook cited in Section 5.

- 3.2.1 The volume calculations for the fuel apply to single pellets of nominal dimensions. However, due to variability in the length of fuel pellets, the number of pellets in each fuel rod is not known. The extrapolation to the volume of the fuel stack assumes that the volume per unit length of the stack is the same as that for the pellet. The basis of this assumption is the observation that because (a) the missing volume due to chamfers, end dishes, and chips is a small fraction of the volume of a fuel pellet, and (b) there are hundreds of pellets in each fuel rod, the irregularities induced by variability in pellet

length and the introduction of a shorter shim pellet in each stack are bound to cause only negligible error in the estimated volume of the stack.

- 3.2.2 The surface area calculation for the fuel applies to a single pellet of nominal dimensions. The extrapolation to the surface area of the fuel stack assumes that the surface area per unit length of the stack is the same as that for the pellet. The basis of this assumption is the observation that because (a) the deviation in surface area due to chamfers and end dishes is a small fraction of the surface area of a fuel pellet, and (b) because there are hundreds of pellets in each fuel rod, the irregularities induced by variability in pellet length and the introduction of a shorter shim pellet in each stack are bound to cause only negligible error in the estimated surface area of the stack.
- 3.2.3 The Blanket and Reflector rods have stainless steel support sleeves and pins to hold the sleeves in place in the plenum. The sleeves and pins are ignored for the volume, mass, and surface-area calculations. The basis of this assumption is the observation that because the sleeve and pin are very small in comparison to a fuel rod, little error is introduced by ignoring them.
- 3.2.4 The mounting-end plugs on fuel rods are treated as cylinders. The portion of cladding that envelops part of the plug is treated as part of the plug. The basis of this assumption is the observation that double-counting error is avoided because the cladding length into which the plug is inserted is not counted as part of the overall cladding length.
- 3.2.5 The hemispherical free-end plugs on fuel rods are treated as cylinders. The portion of cladding that envelops part of the plug is treated as part of the plug. Treating the hemispherical section as cylindrical overstates the mass. However, the excess mass is small compared to the rest of the mass of Zircaloy-4 in the assembly. The basis of this assumption is the observation that the errors induced in the calculated mass and surface area are negligible.
- 3.2.6 The mass and surface area of the spring are calculated as if the spring consisted of a set of tori equal in number to the number of coils. The assumptions result in an underestimate of the spring's mass and surface area because the axial extent of the spring is ignored. The basis of this assumption is the observation that the spring is a small component compared to the rest of the fuel rod and small errors induced in the mass and surface area calculations are negligible.

3.3 ASSUMPTIONS RELATED TO THE SNF ASSEMBLIES

The assumptions in this section are used in the tab labeled "Assemblies" in the Excel workbook cited in Section 5.

- 3.3.1 The shipping plate on a Seed assembly is approximated as a cylindrical ring with 9 holes. This approximation ignores some holes and other recessions, and therefore results in an overstatement of the mass and an understatement of the surface area of the shipping plate. The mass and surface area of the shipping plates are small compared to the mass and surface area of other components of the basket and the canister that are composed of similar stainless steel. Therefore, the basis of this assumption is the observation that the induced error is negligible.
- 3.3.2 A published estimate of the density of AM-350 stainless steel could not be found. For the calculation, the density is taken to be 7.9 g/cm^3 , a reasonable value on the high side based on the range exhibited by other stainless steels (Ref. 7.5, p. 360). The density of AM-350 stainless steel is needed to calculate the mass of the Reflector grids. The mass of the Reflector grids is a small fraction of the overall mass of the Reflector assemblies. Therefore, the basis of this assumption is the observation that the induced error is negligible.
- 3.3.3 The dimensions of the Zircaloy-4 bottom cover plate of the Seed assembly are not available. Therefore, the bottom cover plate is ignored. The mass and surface area of the bottom cover plate are small compared to the mass and surface area of Zircaloy-4 in the rest of the assembly. Therefore, the basis of this assumption is the observation that the errors induced are small.
- 3.3.4 The Zircaloy-4 support shell around the Seed assembly is assumed to run the full length of the assembly. In fact, the support shell ends shortly before reaching the end of the bottom cover plate. The basis of this assumption is the observation that because the bottom cover plate is also composed of Zircaloy-4, the excess length of the support shell compensates somewhat for ignoring the bottom cover plate.
- 3.3.5 The cross-sectional area and perimeter of the Type V Reflector assembly is computed as though the shape of the cross section were a trapezoid with the same maximum dimension and distance between parallel faces. This assumption ignores a small "chip" out of the acute corners. The basis of this assumption is the observation that because the area of the missing pieces is small compared to the entire cross-sectional area, the induced error is small.
- 3.3.6 The lengths of both the Zircaloy-4 guide tube on the inside of the Blanket assemblies and the Zircaloy-4 shell on the outside of the Reflector assemblies are assumed to be the same as the length of the longest fuel rod in the assembly. The basis of this assumption is that the exact lengths are not known and this is a reasonable approximation.

4. USE OF COMPUTER SOFTWARE AND MODELS

4.1 SOFTWARE APPROVED FOR QA WORK

None used.

4.2 SOFTWARE ROUTINES

The calculations were performed in a Microsoft Excel 97 SR-2 workbook on an Intel Pentium processor. The calculations were performed with ordinary Excel formulas that can be verified by visual inspection.

4.3 MODELS

None used.

5. CALCULATION

Attachment I is a printout of the Excel workbook showing the results of the calculations. Reference 7.6 provides the Excel workbook on compact disk (CD) (as documented in Attachment II). The inputs for this calculation are the dimensions and other characteristics of the DOE SNF canisters (Appendix A of Ref. 7.7, including Sheets 1 and 2 of DWG-507692, Sheets 1 and 2 of DWG-507693; see Attachment I for more specific locations) and the Shippingport LWBR SNF (Ref. 7.4, see Attachment I for specific locations) and the densities of the materials from which they are constructed (Refs. 7.1, 7.5, and 7.8; see Attachment I for more specific locations). The values of the inputs can be found in Attachment I and Reference 7.6 (see Attachment II). The formulas used to calculate the results can be found in the Excel workbook by selecting the tab and cell that contains the result for which the formula is desired and viewing the formula bar. The numbers of significant figures preserved in the inputs and results reflect a desire to avoid introducing rounding error into subsequent calculations. Therefore, the number of significant figures reported is not necessarily meaningful at the apparent level of precision.

The results of the calculations rely on inputs that have been categorized as “existing data.” Therefore, results from this calculation that are used as input into documents supporting procurement, fabrication, or construction are required to be identified and tracked as TBV (to be verified) in accordance with appropriate procedures.

5.1 ELEMENTARY FORMULAS FOR VOLUME AND SURFACE AREA

Except as described in Sections 5.2 and 5.3, volume and surface area calculations relied on the elementary formulas provided in Table 5-1. It was often necessary to add or subtract combinations of the elementary formulas to form compound formulas.

Table 5-1. Elementary Formulas for Volume and Surface Area

Description of Calculated Quantity	Formula
Right prism or cylinder of base area A , base perimeter p , and height h	
Volume	Ah
Surface area of the vertical sides	ph
Circle of diameter D	
Area	$\pi D^2/4$
Circumference (or perimeter)	πD
Area of a rectangle of width w and length l	wl
Area of a trapezoid ^a of base length b , top length a , and height h	$h(a + b)/2$
Area of a regular hexagon ^b of largest dimension d	$3(\sqrt{3})(d/2)^2/2$
Area of a parallelogram of base length b , height h	bh
Area of a triangle of base length b , height h	$bh/2$

^aRef. 7.5, p. 567.

^bRef. 7.5, p. 569.

5.2 DERIVATION OF A VOLUME FORMULA FOR FUEL PELLETS

The Shippingport LWBR fuel pellets were right circular cylinders that were dished and chamfered or tapered on both ends (Ref. 7.4, pp. 16, 24, and 30). The formula developed here accounts for the volume taken away from a perfect cylinder by the dishes and chamfers or tapers.

Consider a pellet of length l and diameter D (Figure 5-1). The chamfer or taper at each end has a radial depth d and an axial width w , measuring perpendicular to the surface of the pellet. A dish with a spherical radius r has been hollowed out of each end to a depth h . First, compute the volume of the dishes. The volume of one of the dishes is the volume of the solid obtained by revolving the segment of circle defined by

$$f(x) = \sqrt{(r^2 - x^2)}$$

from $x_1 = r - h$ to $x_2 = r$ circularly around the x -axis. The result is a solid of revolution, the volume of which (Ref. 7.9, pp. 238-239) generally can be computed from the integral

$$V = \int_{x_1}^{x_2} \pi [f(x)]^2 dx.$$

That the integral above represents the volume of a solid of revolution may be verified by noting that $f(x)$ is the radius of a vertical slice through the solid. Therefore, the integral represents the area of the slice times its differential thickness integrated between the ends of the solid, which gives the volume of the solid. Specifically, the volume of one of the end dishes is given by

$$\begin{aligned} V_{dish} &= \int_{r-h}^r \pi [\sqrt{(r^2 - x^2)}]^2 dx \\ &= \int_{r-h}^r \pi (r^2 - x^2) dx \\ &= \pi \left(rh^2 - \frac{h^3}{3} \right). \end{aligned}$$

Next, consider the volume of a chamfered end. The chamfered end takes the shape of a conical frustum, that is, a slice of a cone taken off parallel to the base. Its radius at the base is $D/2$, the same as that of the pellet. Its radius at the top of the slice is reduced by the depth of the chamfer: $D/2 - d$. Its thickness is the width of the chamfer, w . The cone slice can be described by the solid of revolution formed by revolving the line

$$f(x) = \frac{d}{w}x + \left(\frac{D}{2} - d\right)$$

circularly around the x -axis. Its volume, therefore, is given by

$$\begin{aligned} V_{\text{frustum}} &= \int_{D/2-h}^{D/2} \pi \left[\frac{d}{w} x + \left(\frac{D}{2} - d \right) \right]^2 dx \\ &= \pi \frac{D^2}{4} w - \pi \left(\frac{D}{2} dw - \frac{d^2 w}{3} \right). \end{aligned}$$

Because the first term in the result above is the volume of the cylindrical slice with no chamfer, the remaining term is the volume missing from the cylinder due to the chamfer. Taking account of a dish and chamfer on each end, adding the corresponding dish and chamfer volumes, and dividing by the volume of the perfect cylinder gives a missing-to-total volume ratio of

$$\begin{aligned} U &= (2V_{\text{dish}} + 2V_{\text{chamfer}}) / (\pi D^2 l / 4) \\ &= 2[\pi (rh^2 - h^3 / 3) + \pi (Ddw / 2 - d^2 w / 3)] / (\pi D^2 l / 4) \\ &= 8 \frac{(rh^2 - h^3 / 3) + (Ddw / 2 - d^2 w / 3)}{D^2 l}. \end{aligned}$$

Finally, the volume of a pellet is given by the volume of the corresponding perfect cylinder times 1 minus the missing-to-total volume ratio, that is, $(\pi D^2 l / 4)(1 - U)$.

5.3 DERIVATION OF A SURFACE-AREA FORMULA FOR FUEL PELLETS

The formula developed below gives the surface area of a pellet with dishes and chamfers or tapers as a function of the dimensions defined in Section 5.2 and Figure 5-1. The surface area of the pellet can be analyzed into four parts: (1) the cylindrical central band, (2) the conical frustums at each end, (3) the concave dishes on each end, and (4) the shoulders on the ends of the pellet.

The circumference times the height gives the surface area of the central band.

$$S_{\text{band}} = \pi D(l - 2w).$$

The area of a conical frustum is given by the slant height times the arithmetic mean of the circumferences of the top and bottom bases (Ref. 7.5, p. 570).

$$\begin{aligned} S_{\text{frustum}} &= \frac{\pi D + \pi (D - 2d)}{2} \sqrt{d^2 + w^2} \\ &= \pi (D - d) \sqrt{d^2 + w^2}. \end{aligned}$$

To determine the area of the shoulders, first note that the radius of the dish at the top, ρ , is the length of the base of a right triangle with perpendicular side of length $r-h$, and hypotenuse of length r . Therefore,

$$\rho^2 + (r-h)^2 = r^2.$$

So that

$$\rho = \sqrt{2rh - h^2}.$$

The surface area of the shoulder is the area inscribed by the outer circle minus the area inscribed by the inner circle.

$$\begin{aligned} S_{\text{shoulder}} &= \pi \left(\frac{D}{2} - d \right)^2 - \pi \rho^2 \\ &= \pi \left[\left(\frac{D}{2} - d \right)^2 - 2rh + h^2 \right]. \end{aligned}$$

A formula for the area of a dish can be generated by considering the dish as a solid of revolution. The surface area of a solid of revolution (Ref. 7-9, pp. 262-264) is given by

$$S = \int_{x_1}^{x_2} 2\pi f(x) \sqrt{1 + \left[\frac{d}{dx} f(x) \right]^2} dx.$$

The surface area of one of the dishes is the surface area of the solid obtained by revolving the segment of circle defined by

$$f(x) = \sqrt{(r^2 - x^2)}$$

from $x_1 = r - h$ to $x_2 = r$ circularly around the x -axis. Therefore,

$$\begin{aligned} S_{\text{dish}} &= \int_{r-h}^r 2\pi f(x) \sqrt{1 + \left[\frac{d}{dx} f(x) \right]^2} dx \\ &= \int_{r-h}^r 2\pi r dx \\ &= 2\pi r h. \end{aligned}$$

The total surface area of a pellet is

$$\begin{aligned}
 S_{\text{pellet}} &= S_{\text{band}} + 2S_{\text{frustum}} + 2S_{\text{shoulder}} + 2S_{\text{dish}} \\
 &= \pi [D(l - 2w) + 2(D - d)\sqrt{d^2 + w^2} + 2(D/2 - d)^2 - 2(2rh - h^2) + 4rh] \\
 &= \pi [D(l - 2w) + 2(D - d)\sqrt{d^2 + w^2} + 2(D/2 - d)^2 + 2h^2].
 \end{aligned}$$

Note that the spherical radius of the dished ends cancels out of the surface-area formula.

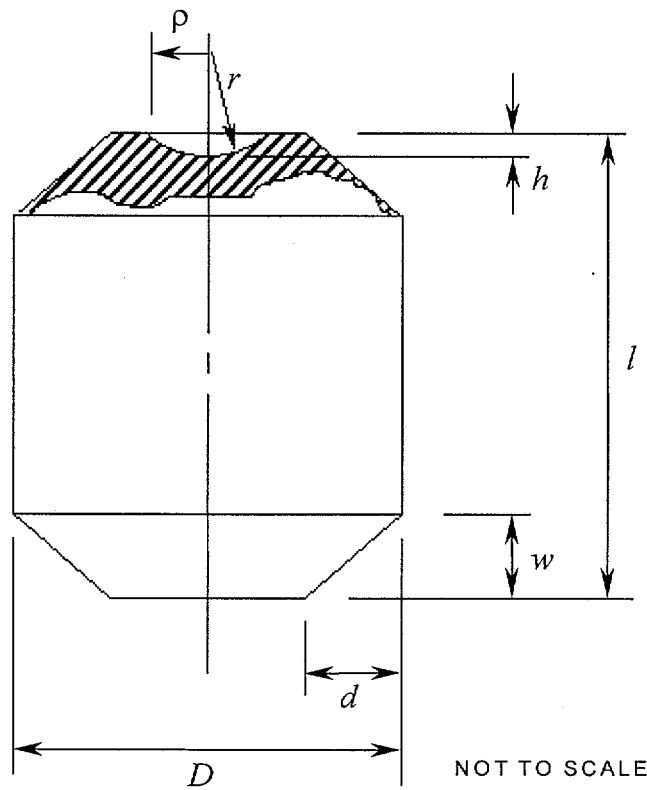

Figure 5-1. Cutaway View of a Fuel Pellet Showing One of the End Dishes and Naming Key Dimensions

6. RESULTS

Complete results from this calculation are included in Attachment I. Reference 7.6 provides, on CD, the Excel workbook used for the calculations. Table 6-1 summarizes the volumes and masses for the DOE canisters and the major components of the Shippingport LWBR SNF.

The results presented rely on inputs that have been categorized as “existing data.” Therefore, results from this calculation that are used as input into documents supporting procurement, fabrication, or construction are required to be identified and tracked as TBV in accordance with appropriate procedures.

Table 6-1. Selected Results

Item	Measure	Computed Value ^a	Units
Canisters			
18-inch canister (empty except for impact plates)	Mass	633.965	kg
18-inch canister (empty except for impact plates)	Capacity	620,762.470	cm ³
Basket structure for 18-in. canister	Mass	400.616	kg
Basket structure for 18-in. canister	Displaced volume ^b	50,202.531	cm ³
Box-shaped spacer for 18-in. canister	Mass	70.573	kg
Box-shaped spacer for 18-in. canister	Displaced volume ^b	8,843.689	cm ³
Volume in 18-in. canister available for SNF & filler	Capacity	561,716.250	cm ³
Filler in 18-in. canister at 75% theoretical density of Al	Mass	793.489	kg
18-in. canister loaded with Seed assembly, basket, etc.	Mass	2,648.843	kg
24-inch canister (empty except for impact plates)	Mass	1,143.085	kg
24-inch canister (empty except for impact plates)	Capacity	1,084,990.722	cm ³
Fuel rods			
Seed fuel rod (max)	Mass	1.132	kg
Standard Blanket fuel rod (max)	Mass	4.192	kg
Power-Flattening Blanket fuel rod (max)	Mass	3.556	kg
Reflector fuel rod (max)	Mass	8.518	kg
Fuel assemblies			
Seed assembly	Mass	758.569	kg
Seed assembly	Displaced volume ^b	169,869.699	cm ³
Seed assembly fuel (binary ^c & thoria ^c)	Volume	5.229E+04	cm ³
Type I Blanket assembly	Mass	1,964.514	kg
Type I Blanket assembly	Displaced volume ^b	507,240.356	cm ³
Type II Blanket assembly	Mass	2,279.399	kg
Type II Blanket assembly	Displaced volume ^b	593,768.921	cm ³
Type III Blanket assembly	Mass	2,480.036	kg
Type III Blanket assembly	Displaced volume ^b	642,249.464	cm ³
Type IV Reflector assembly	Mass	2,188.283	kg
Type IV Reflector assembly	Displaced volume ^b	351,616.139	cm ³
Type V Reflector assembly	Mass	1,769.647	kg
Type V Reflector assembly	Displaced volume ^b	275,662.196	cm ³

^aThe results are not expected to be accurate to the number of significant figures shown. The results shown are verbatim recitations of the results presented in Attachment I.

^bVolume that otherwise would be occupied by a filler. Does not count the volume within the assemblies or inside the guide tubes of the Blanket assemblies.

^cThoria fuel contains only ThO₂. Binary fuel contains a mixture of ThO₂ and UO₂.

7. REFERENCES

- 7.1 CRWMS M&O (Civilian Radioactive Waste Management System Management and Operating Contractor) 1999. *Waste Package Materials Properties*. BBA000000-01717-0210-00017 REV 00. Las Vegas, Nevada: M&O. ACC: MOL.19990407.0172
- 7.2 CRWMS M&O 1996. *Waste Package Filler Material Testing Report*. BBA000000-01717-2500-00008 REV 02. Las Vegas, Nevada: M&O. ACC: MOL.19970121.0004
- 7.3 Brown, R.L. and Richards, J.C. 1970. *Principles of Powder Mechanics: Essays on the Packing and Flow of Powders and Bulk Solids*. pp. 17-21. New York, New York: Pergamon Press. TIC: 245119.
- 7.4 DOE (U.S. Department of Energy) 1999. *Shippingport LWBR (Th/U Oxide) Fuel Characteristics for Disposal Criticality Analysis*. DOE/SNF/REP-051, Revision 0. Idaho Falls, Idaho: Idaho National Engineering and Environmental Laboratory (INEEL), Lockheed Martin Idaho Technologies Company for DOE, Office of Environmental Management. TIC: 245631.
- 7.5 Bauccio, M., ed. 1993. *ASM Metals Reference Book*. Third Edition. Materials Park, Ohio: ASM International. TIC: 240701.
- 7.6 CRWMS M&O 1999. *Electronic Media (CD) for Volumes, Masses, and Surface Areas for Shippingport LWBR Spent Nuclear Fuel in a DOE SNF Canister, BBA000000-01717-0210-00056 REV 00*. Las Vegas, Nevada: M&O. ACC: MOL.19991020.0108.
- 7.7 DOE 1998. *Preliminary Design Specification for Department of Energy Standardized Spent Nuclear Fuel Canisters, Volume I – Design Specification*. DOE/SNF/REP-011, Revision 1. Idaho Falls, Idaho: INEEL, Lockheed Martin Idaho Technologies Company for DOE, Office of Environmental Management. TIC: 241528.
- 7.8 Inco Alloys International, Inc. 1988. *Product Handbook*. IAI-38. Huntington, West Virginia: Inco Alloys International, Inc. TIC: 239397.
- 7.9 Thomas, G.B., Jr. 1972. *Calculus and Analytic Geometry*. Alternate Edition. Reading, Massachusetts: Addison-Wesley Publishing Company, Inc. TIC: 245088.

8. ATTACHMENTS

Attachment I is a printout of the Microsoft Excel workbook that was used to calculate the volumes, masses, and surface areas of the DOE SNF canisters and the Shippingport LWBR SNF. Attachment II describes Ref. 7.6 (a CD that contains the Excel workbook). Attachment III is a sketch of the basket structure and spacer for the DOE 18-inch canister. Table 8-1 provides the list of attachments.

Table 8-1. List of Attachments

Attachment Number	Description of Contents	Extent of Attachment
I	Volume and Mass Inputs and Results for DOE Canister and Shippingport LWBR SNF (printout)	12 pages
II	Attributes of the file printed in Attachment I.	1 page
III	Shippingport LWBR Intact Seed Assembly Basket Assembly. Sketch No. SK-0134 REV 00. 05/11/99.	1 page

	A	B	C
1	Material	Density (g/cm ³)	Reference No. (See Section 7 in Text)
2	AM-350 Stainless Steel	7.9	7.5. Bauccio 1993, p. 360.
3	ASTM A 516 Grade 70 Carbon Steel	7.85	7.1. CRWMS M&O 1999, p. 10.
4	Inconel X-750	8.28	7.8. Inco Alloys International Inc. 1988, p. 11.
5	Stainless Steel 304	7.94	7.1. CRWMS M&O 1999, p. 20.
6	Stainless Steel 316L	7.98	7.1. CRWMS M&O 1999, p. 13.
7	Thoria (ThO ₂)	9.999	7.4. DOE 1999, Table 3-5.
8	Zircaloy-4	6.560	7.1. CRWMS M&O 1999, p. 44.
9	Binary (ThO ₂ & UO ₂) fuel, Seed high-zone	10.042	7.4. DOE 1999, Table 3-5.
10	Binary fuel, Seed low-zone	10.035	7.4. DOE 1999, Table 3-5.
11	Binary fuel, Standard Blanket (SB) low-zone	10.009	7.4. DOE 1999, Table 3-13.
12	Binary fuel, SB medium-zone	10.013	7.4. DOE 1999, Table 3-13.
13	Binary fuel, SB high-zone	10.016	7.4. DOE 1999, Table 3-13.
14	Binary fuel, Power Flattening Blanket (PFB) low-zone	10.013	7.4. DOE 1999, Table 3-14.
15	Binary fuel, PFB medium-zone	10.016	7.4. DOE 1999, Table 3-14.
16	Binary fuel, PFB high-zone	10.022	7.4. DOE 1999, Table 3-14.
17	Aluminum	2.7	7.1. CRWMS M&O 1999, pp. 53-66.
18	Aluminum shot (75% solid fraction)	2.025	(Calculated)

A	B	C	D	E	F	G	H	I
1		Description & Reference	Qty	Units	Input Data		Results	
2					18-in	24-in	18-in	24-in
3		Mass & Volume of Canister, 15-ft long						
4		Main shell (including skirts) (Ref. 7.7, Appendix A, see below for specifics)	1					
5		Outer diameter (DRWG-507692 SHT 1, DRWG-507693 SHT 1)		cm	45.72	60.96		
6		Thickness (DRWG-507692 SHT 1, Item 13; DRWG-507693 SHT 1, Item 13)		cm	0.9525	1.27		
7		Inner diameter		cm			43.815	58.420
8		Length (DRWG-507692 SHT 1, -2 ASMBLY; DRWG-507693 SHT 1, -2 ASMBLY)		cm	456.8698	456.8698		
9		Volume of metal		cm ³			61,202.639	108,804.692
10		Shell mass		kg			488.397	868.261
11		Lifting rings, one at each end (Ref. 7.7, Appendix A, see below for specifics)	2					
12		Outer diameter (DRWG-507692 SHT 2, Detail 11; DRWG-507693 SHT 2, Detail 11)		cm	43.5102	58.1152		
13		Inner diameter (DRWG-507692 SHT 2, Detail 11; DRWG-507693 SHT 2, Detail 11)		cm	38.4302	53.0352		
14		Height (DRWG-507692 SHT 2, Detail 11; DRWG-507693 SHT 2, Detail 11)		cm	1.27	1.27		
15		Volume		cm ³			415.198	563.207
16		Combined mass of lifting rings		kg			6.627	8.989
17		Dished heads (assumed flat, Assump. 3.1.1) (Ref. 7.7, App. A, see below for specifics)	2					
18		Diameter		mm			43.815	58.420
19		Thickness (DRWG-507692 SHT 1, Note 11; DRWG-507693 SHT 1, Note 11)		mm	0.9525	1.27		
20		Area		cm ²			1,507.771	2,680.483
21		Volume of dished heads		cm ³			1,436.152	3,404.213
22		Combined mass of dished heads		kg			22.921	54.331
23		Impact plates (Assump. 3.1.2)(Ref. 7.7, App. A, see below for specifics)	2					
24		Diameter (DRWG-507692 SHT 2, Detail 7; DRWG-507693 SHT 2, Detail 7)		cm	42.545	57.15		
25		Thickness at center (DRWG-507692 SHT 2, Detail 7; DRWG-507693 SHT 2, Detail 7)		cm	5.08	5.08		
26		Volume of impact plates		cm ³			7,221.886	13,031.250
27		Combined mass of both impact plates		kg			113.384	207.979
28		Backing ring (ignoring angular cut, Assump. 3.1.3)(Ref. 7.7, App. A, see below for specifics)	1					
29		Inner diameter (DRWG-507692 SHT 2, -6 ASMBLY; DRWG-507693 SHT 1, -6 ASMBLY)		cm	42.8752	57.4802		
30		Thickness (DRWG-507692 SHT 2, -6 ASMBLY; DRWG-507693 SHT 1, -6 ASMBLY)		cm	0.47752	0.47752		
31		Height (DRWG-507692 SHT 2, -6 ASMBLY; DRWG-507693 SHT 1, -6 ASMBLY)		cm	5.08	5.08		
32		Outer diameter		cm			43.830	58.435
33		Area		cm ²			65.037	86.947
34		Volume		cm ³			330.386	441.689
35		Mass of the backing ring		kg			2.636	3.525
36		Interior basket structure (not applicable [N/A] for 24-in.) (Att. III, see below for specifics)						
37		Length of basket structure (Section A-A)		cm	410.70	N/A		N/A
38		Thickness of plates (Section B-B)		cm	0.95	N/A		N/A
39		A-Plate inner width (Section B-B)		cm	35.49	N/A		N/A
40		A-Plate outer width (Section B-B)		cm	34.03	N/A		N/A
41		B-Plate inner width (Section B-B)		cm	32.40	N/A		N/A
42		B-Plate outer width (Section B-B)		cm	30.55	N/A		N/A
43		A-Plate volume (including cutouts)	2	cm ³		N/A	13,562.135	N/A
44		B-Plate volume (including cutouts)	2	cm ³		N/A	12,280.443	N/A
45		Volume of plate intersection (cutouts)	4	cm ³		N/A	370.657	N/A
46		Total volume of basket		cm ³		N/A	50,202.531	N/A
47		Mass of basket		kg		N/A	400.616	N/A
48		Spacer assembly (Attachment III, see below for specifics)					N/A	N/A
49		Length (Section A-A)		cm	75.7	N/A		N/A
50		Spacer assembly height (Section C-C)		cm	29.3	N/A		N/A
51		Spacer assembly width (Section C-C)		cm	25.5	N/A		N/A
52		Thickness of top plate (Section A-A)		cm	1.91	N/A		N/A
53		Thickness of remaining plates (Section C-C)		cm	0.95	N/A		N/A
54		Volume displaced by empty box		cm ³		N/A	56,559.255	N/A
55		Semi-enclosed interior void volume		cm ³		N/A	47,715.566	N/A
56		Volume of metal		cm ³		N/A	8,843.689	N/A
57		Mass of spacer assembly		kg		N/A	70.573	N/A
58		Mass of empty canister		kg			520.581	935.106
59		Mass of empty canister & impact plates		kg			633.965	1,143.085
60		Mass of canister, impact plates, basket, & spacer		kg			1,105.154	1,143.085

	A	B	C	D	E	F	G	H	I
1	Description & Reference			Qty	Units	Input Data		Results	
61	Mass of the Loaded Canister								
62	Inner diameter				cm			43.815	58.420
63	Inner length (Ref. 7.7, Appendix A, DRWG 507692, SHT 1; DRWG 507693, SHT 1)				cm	411.7086	404.7744		
64	Interior vol. of canister (no backing ring, Assump. 3.1.5)				cm ³			620,762.470	1,084,990.722
65	Volume of basket & spacer metal				cm ³			59,046.220	N/A
66	Volume available for SNF plus filler				cm ³			561,716.250	1,084,990.722
67	Volume of SNF assembly (Assump. 3.1.9, 3.1.10)				cm ³			169,869.699	642,249.464
68	Solid volume of SNF assembly				cm ³			N/A	276,872.067
69	Fluid displacement of assembly, guide tube not plugged				cm ³			N/A	365,377.397
70	Fluid displacement of assembly with plugged guide tube				cm ³			N/A	642,249.464
71	Vol. for filler (including guide tube & space between rods)				cm ³			N/A	719,613.325
72	Vol. for filler (plugged guide tube & no filler between rods)				cm ³			391,846.550	442,741.258
73	Mass of filler (Assump. 3.1.8, without plugged guide tube)				kg			793.489	1,457.217
74	Mass of filler with plugged guide tube (Assump. 3.1.8)				kg			N/A	896.551
75	Mass of SNF assembly (Assump. 3.1.13)(Ref. 7.4, Table 3-4)				kg	750.200	2,728.40		
76	Loaded mass (guide tube not plugged, Assump. 3.1.11)				kg			2,648.843	5,328.702
77	Loaded mass (guide tube plugged, Assump. 3.1.11)				kg			N/A	4,768.036
78	Interior Surface Area of Canister, 15-ft Long								
79	Shell interior surface (ignore backing ring, Assump. 3.1.4)			1	m ²			5.667	7.429
80	Face of an impact plate (assumed cylindrical)			4	m ²			0.142	0.257
81	Edge of an impact plate (assumed cylindrical)			2	m ²			0.068	0.091
82	Face of a dished end (assumed flat)			2	m ²			0.151	0.268
83	Total interior surface area				m ²			6.673	9.173
84	Surface Area of Basket								
85	Area of A-Plate (use inner width etc., Assump. 3.1.12)				m ²			2.915	N/A
86	Area of B-Plate (use inner width etc., Assump. 3.1.12)				m ²			2.661	N/A
87	Total surface area of basket				m ²			11.153	N/A
88	Surface Area of Spacer								
89	Area of box (counts upper, inner surface & edges)				m ²			0.979	N/A
90	Area of inner vertical faces				m ²			0.753	N/A
91	Total surface area of spacer				m ²			1.732	N/A
92	Exterior Surface Area of Canister, 15-ft Long								
93	Shell exterior (ignore edge, Assump. 3.1.6)			1	m ²			6.562	8.750
94	Length of end skirt (Ref. 7.7, Appendix A, DRWGS 507692 & 50793, SHT 1, -6 ASMBLY)				cm	20.32	22.86		
95	Inside surface area of end skirt			2	m ²			0.280	0.420
96	Outside face of a curved end plate (assumed flat)			2	m ²			0.151	0.268
97	Face of a lifting ring (ignore inner edge, Assump. 3.1.7)			4	m ²			0.033	0.044
98	Total exterior surface area				m ²			7.554	10.302
99									
100	N/A = not applicable. DRWG = Drawing. SHT = Sheet. ASMBLY = Assembly. App. = Appendix. Assump. = Assumption. Att. = Attachment. Qty = Quantity.								

	A	B	C	D	E	F	G	H	I
1				Description	Ref. 7.4:	Quantity	Units	Input Data	Result
2				Seed Assembly (Assump. 3.3.3)					
3				Fuel rods					
4				Mass of a full assembly of rods			kg		697.596
5				Grid structures	Sect. 3.1.1.1.3	9			
6				Mass of a single grid	Sect. 3.1.1.1.3		kg	1.542	
7				Mass of a full assembly of grids			kg		13.878
8				Hexagonal Zircaloy-4 shell	Sect. 3.1.1.1.3	1			
9				Length of hexagonal shell (Assump. 3.3.5)	Sect. 3.1.1.1.3		mm	3302	
10				Maximum corner-to-corner width of an assembly	Sect. 3.1.1.1.3		mm	281.432	
11				Thickness of a shell face	Sect. 3.1.1.1.3		mm	2.032	
12				Exterior width of a shell face			mm		140.716
13				Interior width of a shell face			mm		138.370
14				Surface area of shell			cm ²		55,292.449
15				Cross-sectional area of the assembly			cm ²		514.445
16				Volumetric displacement of the hexagonal prism			cm ³		169,869.699
17				Volume of the interior of the hexagonal shell			cm ³		164,251.987
18				Volume of the shell			cm ³		5,617.713
19				Mass of the hexagonal shell			kg		36.852
20				Shipping plate (Assump. 3.3.1)	Sect. 3.1.1.1.3	1			
21				Outer diameter	Sect. 3.1.1.1.3		mm	244.5512	
22				Inner diameter	Sect. 3.1.1.1.3		mm	155.956	
23				Thickness	Sect. 3.1.1.1.3		mm	50.8	
24				Diameter of large holes	Sect. 3.1.1.1.3	3	mm	25.4	
25				Diameter of small holes	Sect. 3.1.1.1.3	6	mm	14.224	
26				Volume of ring without holes			cm ³		1,415.709
27				Volume of holes			cm ³		125.656
28				Volume of ring with holes			cm ³		1,290.053
29				Area of inner and outer ring surfaces			cm ²		639.181
30				Area of top & bottom faces of ring			cm ²		557.366
31				Surface area of large holes			cm ²		121.610
32				Surface area of small holes			cm ²		136.203
33				Surface area of ring with holes			cm ²		1,454.360
34				Mass of ring with holes			kg		10.243
35				Seed assembly mass			kg		758.569

	A	B	C	D	E	F	G	H	I
1				Description	Ref. 7.4:	Quantity	Units	Input Data	Result
36				Type I Blanket Assembly					
37				Fuel rods					
38				Mass of a full assembly of rods			kg		1,856.924
39				Grid structures	Sect. 3.1.1.2.3	8			
40				Mass of a standard grid	Table 3-18		kg	2.232	
41				Mass of a power-flattening grid (none for Type I)			kg	N/A	
42				Mass of a full assembly of grids			kg		17.856
43				Zircaloy-4 guide tube					
44				Minimum width of a blanket assembly interior	Table 3-17		mm	258.572	
45				Thickness of interior guide tube	Table 3-17		mm	4.826	
46				Length of a shell face (Assumption 3.3.6)	Table 3-15		mm	3106.42	
47				Interior width of a shell face			mm		149.287
48				Exterior width of a guide tube face			mm		154.859
49				Surface area of guide tube			cm ²		56,688.278
50				Volume of the interior of the guide tube			cm ³		179,867.954
51				Volumetric displacement of the hexagonal prism			cm ³		193,546.836
52				Volume of the guide tube			cm ³		13,678.881
53				Mass of the hexagonal guide tube			kg		89.733
54				Maximum corner-to-corner dimension	Table 3-17		mm	501.396	
55				Cross-sectional area of the assembly			cm ²		1,632.878
56				Displacement of the assembly's exterior outline			cm ³		507,240.356
57				Total mass			kg		1,964.514
58				Type II Blanket Assembly					
59				Fuel rods					
60				Mass of a full assembly of rods			kg		2,166.978
61				Grid structures	Sect. 3.1.1.2.3	8			
62				Mass of a standard grid	Table 3-18		kg	1.312	
63				Mass of a power-flattening grid	Table 3-18		kg	1.524	
64				Mass of a full assembly of grids			kg		22.688
65				Zircaloy-4 guide tube faces (same as Type I)					
66				Larger distance between exterior faces	Table 3-17		mm	489.996	
67				Smaller distance between exterior faces	Table 3-17		mm	434.4416	
68				Excess width between exterior faces			mm		55.554
69				Cross-sectional area of the assembly			cm ²		1,911.425
70				Displacement of the assembly's exterior outline			cm ³		593,768.921
71				Total mass			kg		2,279.399
72				Type III Blanket Assembly					
73				Fuel rods					
74				Mass of a full assembly of rods			kg		2,365.055
75				Grid structures	Sect. 3.1.1.2.3	8			
76				Mass of a standard grid	Table 3-18		kg	0.933	
77				Mass of a power-flattening grid	Table 3-18		kg	2.223	
78				Mass of a full assembly of grids			kg		25.248
79				Zircaloy-4 guide tube faces (same as Type I)					
80				Maximum corner-to-corner dimension			mm		561.848
81				Cross-sectional area of the assembly			cm ²		2,067.491
82				Displacement of the assembly's exterior outline			cm ³		642,249.464
83				Total mass			kg		2,480.036

1	A	B	C	D	E	F	G	H	I
				Description	Ref. 7.4:	Quantity	Units	Input Data	Result
84				Type IV Reflector Assembly					
85				Fuel rods					
86				Mass of a full assembly of rods			kg		1,937.246
87				Grid structures		N/A			
88				Volume of grid metal per rod	Sect. 3.1.1.3.3		cm ³	6.915	
89				Fraction of grid metal in fuel lattice	Sect. 3.1.1.3.3		none	0.8	
90				Total volume of grid metal in assembly			cm ³		1,970.775
91				Mass of a full assembly of grids (Assump. 3.3.2)			kg		15.569
92				Zircaloy-4 shell faces		N/A			
93				Length of a shell face (Assumption 3.3.6)	Table 3-20		mm	2813.558	
94				Maximum corner-to-corner width of an assembly	Table 3-21		mm	489.204	
95				Width of widest face	Table 3-21		mm	434.4416	
96				Thickness of widest face	Table 3-21		mm	16.51	
97				"Roof point" to "foundation" measurement	Table 3-21		mm	350.3676	
98				Width of "wall" faces			mm		224.902
99				Thickness of "wall" faces	Table 3-21		mm	5.334	
100				Width of "roof" faces			mm		250.851
101				Thickness of "roof" faces	Table 3-21		mm	6.35	
102				Volume of shell			cm ³		35,894.532
103				Surface area of shell			cm ²		77,988.957
104				Mass of shell			kg		235.468
105				Cross-sectional area of the assembly			cm ²		1,249.721
106				Displacement of the assembly's exterior outline			cm ³		351,616.139
107				Total mass			kg		2,188.283
108				Type V Reflector Assembly					
109				Fuel rods					
110				Mass of a full assembly of rods			kg		1,410.522
111				Grid structures		N/A			
112				Volume of grid metal per rod	Sect. 3.1.1.3.3		cm ³	6.915	
113				Fraction of grid metal in fuel lattice	Sect. 3.1.1.3.3		none	0.8	
114				Total volume of grid metal in assembly			cm ³		1,434.863
115				Mass of a full assembly of grids			kg		11.335
116				Zircaloy-4 shell faces (Assump. 3.3.5)		N/A			
117				Length of a shell face (Assumption 3.3.6)	Table 3-20		mm	2813.558	
118				Maximum corner-to-corner width of an assembly	Table 3-21		mm	539.877	
119				Thickness of widest face	Table 3-21		mm	16.51	
120				Width of face parallel to widest face	Table 3-21		mm	314.9346	
121				Thickness of parallel face	Table 3-21		mm	7.62	
122				Distance between parallel faces	Table 3-21		mm	229.235	
123				Width of sloping faces			mm		264.698
124				Thickness of sloping faces	Table 3-21		mm	14.224	
125				Volume of shell			cm ³		53,016.699
126				Surface area of shell			cm ²		77,890.942
127				Mass of shell			kg		347.790
128				Cross-sectional area of the assembly			cm ²		979.764
129				Displacement of the assembly's exterior outline			cm ³		275,662.196
130				Total mass			kg		1,769.647
131									
132				N/A = not applicable					

A	B	C	D	E	F	G	H	I	J	K	L	M	N
1	Fuel Region (Std.=Standard, Blkt.=Blanket, PF=Power Flattening)				Seed	Seed	Seed	Seed	Seed	Seed	Seed	Seed	
2	Rod Type				01	02	03	04	05	06	07	08	Seed
3	Regional Enrichment Zone				Low	Low	Low	Low	High	High	Low	Low	Assembly
4	Rod Mounting Location				Bottom	Top	Bottom	Top	Bottom	Top	Bottom	Top	Sums
5	INPUTS (Ref. 7.4, Tables 3-5, 3-13, 3-14, Sect. 3.1.1.3 except as noted)	Qty	Units										
6	Binary (ThO ₂ & UO ₂) fuel pellet stack	1											
7	Fissile (U ²³³ & U ²³⁵) concentration (Table 3-7)		wt%		4.337	4.337	4.337	4.337	5.202	5.202	4.337	4.337	
8	Pellet diameter, <i>D</i>		mm		6.4008	6.4008	6.4008	6.4008	6.4008	6.4008	6.4008	6.4008	
9	Pellet length, <i>l</i>		mm		11.2776	11.2776	11.2776	11.2776	15.621	15.621	11.2776	11.2776	
10	End dish spherical radius, <i>r</i>		mm		9.144	9.144	9.144	9.144	9.144	9.144	9.144	9.144	
11	End dish depth, <i>h</i>		mm		0.2286	0.2286	0.2286	0.2286	0.2286	0.2286	0.2286	0.2286	
12	Chamfer radial depth, <i>d</i>		mm		0.381	0.381	0.381	0.381	0.381	0.381	0.381	0.381	
13	Chamfer axial width, <i>w</i>		mm		0.381	0.381	0.381	0.381	0.381	0.381	0.381	0.381	
14	Binary pellet stack height (Table 3-7)		mm		1066.8	1066.8	1422.4	1778	2133.6	2133.6	1066.8	1066.8	
15	Percent theoretical density, binary fuel		%		97.712	97.712	97.712	97.712	97.554	97.554	97.712	97.712	
16	Void fraction (Compare Row 54)		none		0.01704	0.01704	0.01704	0.01704	0.01172	0.01172	0.01704	0.01704	
17	Thoria (ThO ₂ only) fuel pellet stack												
18	Pellet diameter, <i>D</i>		mm		6.49224	6.49224	6.49224	6.49224	6.49224	6.49224	6.49224	6.49224	
19	Pellet length, <i>l</i>		mm		13.462	13.462	13.462	13.462	13.462	13.462	13.462	13.462	
20	End dish spherical radius, <i>r</i>		mm		7.5692	7.5692	7.5692	7.5692	7.5692	7.5692	7.5692	7.5692	
21	End dish depth, <i>h</i>		mm		0.2286	0.2286	0.2286	0.2286	0.2286	0.2286	0.2286	0.2286	
22	Chamfer radial depth, <i>d</i>		mm		0.381	0.381	0.381	0.381	0.381	0.381	0.381	0.381	
23	Chamfer axial width, <i>w</i>		mm		0.381	0.381	0.381	0.381	0.381	0.381	0.381	0.381	
24	Total fuel stack height (Tables 3-7, 3-16, 3-19)		mm		2635.25	2635.25	2635.25	2635.25	2635.25	2635.25	2635.25	2635.25	
25	Thoria percent theoretical density		%		98.013	98.013	98.013	98.013	98.013	98.013	98.013	98.013	
26	Void fraction (Compare Row 64)		none		0.01253	0.01253	0.01253	0.01253	0.01253	0.01253	0.01253	0.01253	
27	Cladding	1											
28	Plenum length (Section 3.1.1.1.2, Tables 3-16, 3-19)		mm		254	254	254	254	254	254	254	254	
29	Outside diameter (Table 3-8)		mm		7.78002	7.78002	7.78002	7.78002	7.78002	7.78002	7.78002	7.78002	
30	Thickness (Table 3-8)		mm		0.563118	0.563118	0.563118	0.563118	0.563118	0.563118	0.563118	0.563118	
31	Fixed-end plug and stem (Sect. 3.1.1.1.2, Tables 3-6, 3-15, 3-16, 3-20)	1											
32	Diameter of main body (including cladding)		mm		7.78002	7.78002	7.78002	7.78002	7.78002	7.78002	7.78002	7.78002	
33	Length of main body (including cladding)		mm		52.578	44.958	52.578	44.958	52.578	44.958	52.578	44.958	
34	Diameter of mounting stem (max)		mm		5.7658	5.7658	5.7658	5.7658	5.7658	5.7658	5.7658	5.7658	
35	Length of mounting stem (uncut)		mm		60.96	60.96	64.008	64.008	67.31	67.31	44.45	44.45	
36	Free-end plug (Sect. 3.1.1.1.2, Tables 3-6, 3-15, 3-16, 3-20)	1											
37	Diameter of plug (including cladding)		mm		7.78002	7.78002	7.78002	7.78002	7.78002	7.78002	7.78002	7.78002	
38	Length of plug including hemispherical end		mm		19.05	26.67	19.05	26.67	19.05	26.67	19.05	26.67	
39	Inconel plenum spring (Table 3-9)	1											
40	Number of coils		none		190	190	190	190	190	190	190	190	
41	Wire diameter		mm		1.0795	1.0795	1.0795	1.0795	1.0795	1.0795	1.0795	1.0795	
42	Spring mean diameter		mm		5.2578	5.2578	5.2578	5.2578	5.2578	5.2578	5.2578	5.2578	
43	Number of rods per seed assembly (Table 3-6)		none		30	84	72	66	181	150	30	6	6.190E+02
44	Number of rods per blanket assembly of Type I (Table 3-19)		none		0	0	0	0	0	0	0	0	0.000E+00
45	Number of rods per blanket assembly of Type II (Table 3-19)		none		0	0	0	0	0	0	0	0	0.000E+00
46	Number of rods per blanket assembly of Type III (Table 3-19)		none		0	0	0	0	0	0	0	0	0.000E+00
47	Number of rods per reflector assembly of Type IV (Table 3-19)		none		0	0	0	0	0	0	0	0	0.000E+00
48	Number of rods per reflector assembly of Type V (Table 3-19)		none		0	0	0	0	0	0	0	0	0.000E+00

A	B	C	D	E	F	G	H	I	J	K	L	M	N
1		Fuel Region (Std.=Standard, Blkt.=Blanket, PF=Power Flattening)			Seed	Seed	Seed	Seed	Seed	Seed	Seed	Seed	
2		Rod Type			01	02	03	04	05	06	07	08	Seed
3		Regional Enrichment Zone			Low	Low	Low	Low	High	High	Low	Low	Assembly
4		Rod Mounting Location			Bottom	Top	Bottom	Top	Bottom	Top	Bottom	Top	Sums
49		RESULTS (Assump. 3.2.3, this Calculation)											
50		Binary fuel pellet stack	1										
51		Surface area of a single pellet (Section 5.3)		mm ²	2.821E+02	2.821E+02	2.821E+02	2.821E+02	3.694E+02	3.694E+02	2.821E+02	2.821E+02	
52		Surface area per unit stack length		mm ² /mm	2.501E+01	2.501E+01	2.501E+01	2.501E+01	2.365E+01	2.365E+01	2.501E+01	2.501E+01	
53		Surface area of the binary stack (Assump. 3.2.2)		mm ²	2.669E+04	2.669E+04	3.558E+04	4.448E+04	5.046E+04	5.046E+04	2.669E+04	2.669E+04	2.620E+07
54		Missing-to-total volume ratio (Section 5.2)		none	0.01593	0.01593	0.01593	0.01593	0.01150	0.01150	0.01593	0.01593	
55		Volume of a perfectly cylindrical stack		cm ³	3.433E+01	3.433E+01	4.577E+01	5.721E+01	6.865E+01	6.865E+01	3.433E+01	3.433E+01	3.495E+04
56		Vol. of stack with as-built void fract. (Assump. 3.2.1)		cm ³	3.374E+01	3.374E+01	4.499E+01	5.624E+01	6.785E+01	6.785E+01	3.374E+01	3.374E+01	3.447E+04
57		Mass of binary fuel stack		kg	3.309E-01	3.309E-01	4.411E-01	5.514E-01	6.647E-01	6.647E-01	3.309E-01	3.309E-01	3.378E+02
58		Fissile loading		g	1.435E+01	1.435E+01	1.913E+01	2.392E+01	3.458E+01	3.458E+01	1.435E+01	1.435E+01	1.655E+04
59		Thoria fuel pellet stack											
60		Thoria pellet stack height		mm	1.568E+03	1.568E+03	1.213E+03	8.573E+02	5.017E+02	5.017E+02	1.568E+03	1.568E+03	
61		Surface area of a single pellet (Section 5.3)		mm ²	3.316E+02	3.316E+02	3.316E+02	3.316E+02	3.316E+02	3.316E+02	3.316E+02	3.316E+02	
62		Surface area per unit stack length		mm ² /mm	2.463E+01	2.463E+01	2.463E+01	2.463E+01	2.463E+01	2.463E+01	2.463E+01	2.463E+01	
63		Surface area of the thoria stack		mm ²	3.864E+04	3.864E+04	2.988E+04	2.112E+04	1.236E+04	1.236E+04	3.864E+04	3.864E+04	1.343E+07
64		Missing-to-total volume ratio (Section 5.2)		none	0.01190	0.01190	0.01190	0.01190	0.01190	0.01190	0.01190	0.01190	
65		Volume of a perfectly cylindrical stack		cm ³	5.192E+01	5.192E+01	4.015E+01	2.838E+01	1.661E+01	1.661E+01	5.192E+01	5.192E+01	1.805E+04
66		Volume of stack given as-built void fraction		cm ³	5.127E+01	5.127E+01	3.965E+01	2.802E+01	1.640E+01	1.640E+01	5.127E+01	5.127E+01	1.782E+04
67		Mass of thoria fuel stack		kg	5.025E-01	5.025E-01	3.886E-01	2.746E-01	1.607E-01	1.607E-01	5.025E-01	5.025E-01	1.747E+02
68		Cladding	1										
69		Cladding length excluding end plug cladding		mm	2.889E+03	2.889E+03	2.889E+03	2.889E+03	2.889E+03	2.889E+03	2.889E+03	2.889E+03	
70		Inside diameter		mm	6.654E+00	6.654E+00	6.654E+00	6.654E+00	6.654E+00	6.654E+00	6.654E+00	6.654E+00	
71		Surface area		mm ²	1.310E+05	1.310E+05	1.310E+05	1.310E+05	1.310E+05	1.310E+05	1.310E+05	1.310E+05	8.110E+07
72		Volume		cm ³	3.689E+01	3.689E+01	3.689E+01	3.689E+01	3.689E+01	3.689E+01	3.689E+01	3.689E+01	2.283E+04
73		Mass of Zircaloy-4 cladding		kg	2.420E-01	2.420E-01	2.420E-01	2.420E-01	2.420E-01	2.420E-01	2.420E-01	2.420E-01	1.498E+02
74		Mounting-end plug and stem (Assump. 3.2.4)	1										
75		Volume of main body		cm ³	2.500E+00	2.137E+00	2.500E+00	2.137E+00	2.500E+00	2.137E+00	2.500E+00	2.137E+00	
76		Volume of stem		cm ³	1.592E+00	1.592E+00	1.671E+00	1.671E+00	1.757E+00	1.757E+00	1.161E+00	1.161E+00	
77		Surface area (ignore clad thickness)		mm ²	2.484E+03	2.298E+03	2.540E+03	2.353E+03	2.599E+03	2.413E+03	2.185E+03	1.999E+03	1.516E+06
78		Total volume of plug & stem		cm ³	4.091E+00	3.729E+00	4.171E+00	3.809E+00	4.257E+00	3.895E+00	3.660E+00	3.298E+00	2.472E+03
79		Mass of mounting-end plug and stem		kg	2.684E-02	2.446E-02	2.736E-02	2.498E-02	2.793E-02	2.555E-02	2.401E-02	2.163E-02	1.622E+01
80		Free-end closure plug (Assump. 3.2.5)	1										
81		Surface area (ignore clad thickness)		mm ²	5.607E+02	7.469E+02	5.607E+02	7.469E+02	5.607E+02	7.469E+02	5.607E+02	7.469E+02	4.041E+05
82		Volume of plug		cm ³	9.056E-01	1.268E+00	9.056E-01	1.268E+00	9.056E-01	1.268E+00	9.056E-01	1.268E+00	6.714E+02
83		Mass of free-end plug		kg	5.941E-03	8.317E-03	5.941E-03	8.317E-03	5.941E-03	8.317E-03	5.941E-03	8.317E-03	4.405E+00
84		Inconel plenum spring (Assump. 3.2.6)	1										
85		Uncoiled wire length (assuming circular coils)		mm	3.138E+03	3.138E+03	3.138E+03	3.138E+03	3.138E+03	3.138E+03	3.138E+03	3.138E+03	
86		Surface area (ignore ends)		mm ²	1.064E+04	1.064E+04	1.064E+04	1.064E+04	1.064E+04	1.064E+04	1.064E+04	1.064E+04	6.588E+06
87		Spring volume		cm ³	2.872E+00	2.872E+00	2.872E+00	2.872E+00	2.872E+00	2.872E+00	2.872E+00	2.872E+00	1.778E+03
88		Spring mass		kg	2.378E-02	2.378E-02	2.378E-02	2.378E-02	2.378E-02	2.378E-02	2.378E-02	2.378E-02	1.472E+01
89		Mass of fuel rod (Assump. 3.2.3)		kg	1.132E+00	1.132E+00	1.129E+00	1.125E+00	1.125E+00	1.125E+00	1.129E+00	1.129E+00	6.976E+02
90		Solid volume of fuel rod		cm ³	1.298E+02	1.298E+02	1.295E+02	1.291E+02	1.292E+02	1.292E+02	1.293E+02	1.293E+02	8.005E+04
91		Fuel volume (binary & thoria)		cm ³	8.501E+01	8.501E+01	8.464E+01	8.426E+01	8.425E+01	8.425E+01	8.501E+01	8.501E+01	5.229E+04

A	B	C	D	E	O	P	Q	R	S	T	U	V	W	X
1	Fuel Region (Std.=Standard, Blkt.=Blanket, PF=Power Flattening)				Std. Blkt.	Std. Blkt.	Std. Blkt.	Std. Blkt.	Std. Blkt.	Std. Blkt.	PF Blkt.	PF Blkt.	PF Blkt.	PF Blkt.
2	Rod Type				11	12	13	14	15	16	21	22	23	24
3	Regional Enrichment Zone				Low	Low	High	Medium	Medium	High	Low	Low	High	Medium
4	Rod Mounting Location				Bottom	Top	Bottom	Top	Bottom	Top	Bottom	Top	Bottom	Top
5	INPUTS (Ref. 7.4, Tables 3-5, 3-13, 3-14, Sect. 3.1.1.3 except as noted)		Qty	Units										
6	Binary (ThO ₂ & UO ₂) fuel pellet stack		1											
7	Fissile (U ²³³ & U ²³⁵) concentration (Table 3-7)			wt%	1.214	1.214	2.005	1.668	1.668	2.005	1.654	1.654	2.739	2.009
8	Pellet diameter, <i>D</i>			mm	12.9667	12.9667	12.9667	12.9667	12.9667	12.9667	11.9253	11.9253	11.9278	11.9253
9	Pellet length, <i>l</i>			mm	13.487	13.487	19.939	22.0472	22.0472	19.939	22.098	22.098	17.8054	19.9644
10	End dish spherical radius, <i>r</i>			mm	36.5506	36.5506	36.5506	36.5506	36.5506	36.5506	29.4894	29.4894	29.4894	29.4894
11	End dish depth, <i>h</i>			mm	0.3556	0.3556	0.3556	0.3556	0.3556	0.3556	0.3556	0.3556	0.3556	0.3556
12	Chamfer radial depth, <i>d</i>			mm	0.0762	0.0762	0.0762	0.0762	0.0762	0.0762	0.06096	0.06096	0.06096	0.06096
13	Chamfer axial width, <i>w</i>			mm	3.81	3.81	3.81	3.81	3.81	3.81	3.81	3.81	3.81	3.81
14	Binary pellet stack height (Table 3-7)			mm	1066.8	1066.8	1778	1422.4	2133.6	2133.6	1066.8	1066.8	1778	1442.4
15	Percent theoretical density, binary fuel			%	98.608	98.608	98.115	98.224	98.224	98.115	98.034	98.034	97.906	98.041
16	Void fraction (Compare Row 54)			none	0.02494	0.02494	0.016	0.01335	0.01335	0.016	0.01998	0.01998	0.01578	0.01753
17	Thoria (ThO ₂ only) fuel pellet stack													
18	Pellet diameter, <i>D</i>			mm	12.9667	12.9667	12.9667	12.9667	12.9667	12.9667	11.9278	11.9278	11.9278	11.9278
19	Pellet length, <i>l</i>			mm	15.6464	15.6464	15.6464	15.6464	15.6464	15.6464	11.3538	11.3538	11.3538	11.3538
20	End dish spherical radius, <i>r</i>			mm	36.5506	36.5506	36.5506	36.5506	36.5506	36.5506	29.4894	29.4894	29.4894	29.4894
21	End dish depth, <i>h</i>			mm	0.3556	0.3556	0.3556	0.3556	0.3556	0.3556	0.3556	0.3556	0.3556	0.3556
22	Chamfer radial depth, <i>d</i>			mm	0.1524	0.1524	0.1524	0.1524	0.1524	0.1524	0.1524	0.1524	0.1524	0.1524
23	Chamfer axial width, <i>w</i>			mm	0.1524	0.1524	0.1524	0.1524	0.1524	0.1524	0.1524	0.1524	0.1524	0.1524
24	Total fuel stack height (Tables 3-7, 3-16, 3-19)			mm	2633.726	2660.396	2633.726	2660.396	2633.726	2660.396	2633.726	2660.396	2633.726	2660.396
25	Thoria percent theoretical density			%	97.796	97.796	97.796	97.796	97.796	97.796	98.057	98.057	98.057	98.057
26	Void fraction (Compare Row 64)			none	0.01399	0.01399	0.01399	0.01399	0.01399	0.01399	0.01966	0.01966	0.01966	0.01966
27	Cladding		1											
28	Plenum length (Section 3.1.1.1.2, Tables 3-16, 3-19)			mm	251.46	251.46	251.46	251.46	251.46	251.46	251.46	251.46	251.46	251.46
29	Outside diameter (Table 3-8)			mm	14.52118	14.52118	14.52118	14.52118	14.52118	14.52118	13.39596	13.39596	13.39596	13.39596
30	Thickness (Table 3-8)			mm	0.713232	0.713232	0.713232	0.713232	0.713232	0.713232	0.671068	0.671068	0.671068	0.671068
31	Fixed-end plug and stem (Sect. 3.1.1.1.2, Tables 3-6, 3-15, 3-16, 3-20)		1											
32	Diameter of main body (including cladding)			mm	14.52118	14.52118	14.52118	14.52118	14.52118	14.52118	13.39596	13.39596	13.39596	13.39596
33	Length of main body (including cladding)			mm	67.31	33.02	67.31	33.02	67.31	33.02	67.31	33.02	67.31	33.02
34	Diameter of mounting stem (max)			mm	8.763	8.763	8.763	8.763	8.763	8.763	8.763	8.763	8.763	8.763
35	Length of mounting stem (uncut)			mm	107.442	107.442	110.49	110.49	113.538	113.538	107.442	107.442	110.49	110.49
36	Free-end plug (Sect. 3.1.1.1.2, Tables 3-6, 3-15, 3-16, 3-20)		1											
37	Diameter of plug (including cladding)			mm	14.52118	14.52118	14.52118	14.52118	14.52118	14.52118	13.39596	13.39596	13.39596	13.39596
38	Length of plug including hemispherical end			mm	34.29	41.91	34.29	41.91	34.29	41.91	34.29	41.91	34.29	41.91
39	Inconel plenum spring (Table 3-9)		1											
40	Number of coils			none	125	125	125	125	125	125	135	135	135	135
41	Wire diameter			mm	1.81102	1.81102	1.81102	1.81102	1.81102	1.81102	1.66624	1.66624	1.66624	1.66624
42	Spring mean diameter			mm	9.1694	9.1694	9.1694	9.1694	9.1694	9.1694	8.4328	8.4328	8.4328	8.4328
43	Number of rods per seed assembly (Table 3-6)			none	0	0	0	0	0	0	0	0	0	0
44	Number of rods per blanket assembly of Type I (Table 3-19)			none	60	66	78	72	84	84	0	0	0	0
45	Number of rods per blanket assembly of Type II (Table 3-19)			none	39	41	45	43	46	47	21	25	33	29
46	Number of rods per blanket assembly of Type III (Table 3-19)			none	29	30	32	31	32	33	31	36	46	41
47	Number of rods per reflector assembly of Type IV (Table 3-19)			none	0	0	0	0	0	0	0	0	0	0
48	Number of rods per reflector assembly of Type V (Table 3-19)			none	0	0	0	0	0	0	0	0	0	0

A	B	C	D	E	O	P	Q	R	S	T	U	V	W	X
1		Fuel Region (Std.=Standard, Blkt.=Blanket, PF=Power Flattening)			Std. Blkt.	Std. Blkt.	Std. Blkt.	Std. Blkt.	Std. Blkt.	Std. Blkt.	PF Blkt.	PF Blkt.	PF Blkt.	PF Blkt.
2		Rod Type			11	12	13	14	15	16	21	22	23	24
3		Regional Enrichment Zone			Low	Low	High	Medium	Medium	High	Low	Low	High	Medium
4		Rod Mounting Location			Bottom	Top	Bottom	Top	Bottom	Top	Bottom	Top	Bottom	Top
49		RESULTS (Assump. 3.2.3, this Calculation)												
50		Binary fuel pellet stack	1											
51		Surface area of a single pellet (Section 5.3)		mm ²	8.064E+02	8.064E+02	1.069E+03	1.155E+03	1.155E+03	1.069E+03	1.046E+03	1.046E+03	8.855E+02	9.662E+02
52		Surface area per unit stack length		mm ² /mm	5.979E+01	5.979E+01	5.362E+01	5.239E+01	5.239E+01	5.362E+01	4.734E+01	4.734E+01	4.973E+01	4.839E+01
53		Surface area of the binary stack (Assump. 3.2.2)		mm ²	6.378E+04	6.378E+04	9.534E+04	7.452E+04	1.118E+05	1.144E+05	5.050E+04	5.050E+04	8.843E+04	6.980E+04
54		Missing-to-total volume ratio (Section 5.2)		none	0.02287	0.02287	0.01547	0.01399	0.01399	0.01547	0.01297	0.01297	0.01609	0.01435
55		Volume of a perfectly cylindrical stack		cm ³	1.409E+02	1.409E+02	2.348E+02	1.878E+02	2.817E+02	2.817E+02	1.192E+02	1.192E+02	1.987E+02	1.611E+02
56		Vol. of stack with as-built void fract. (Assump. 3.2.1)		cm ³	1.374E+02	1.374E+02	2.310E+02	1.853E+02	2.780E+02	2.772E+02	1.168E+02	1.168E+02	1.955E+02	1.583E+02
57		Mass of binary fuel stack		kg	1.356E+00	1.356E+00	2.270E+00	1.823E+00	2.734E+00	2.724E+00	1.146E+00	1.146E+00	1.919E+00	1.554E+00
58		Fissile loading		g	1.646E+01	1.646E+01	4.552E+01	3.040E+01	4.560E+01	5.463E+01	1.896E+01	1.896E+01	5.255E+01	3.123E+01
59		Thoria fuel pellet stack												
60		Thoria pellet stack height		mm	1.567E+03	1.594E+03	8.557E+02	1.238E+03	5.001E+02	5.268E+02	1.567E+03	1.594E+03	8.557E+02	1.218E+03
61		Surface area of a single pellet (Section 5.3)		mm ²	8.949E+02	8.949E+02	8.949E+02	8.949E+02	8.949E+02	8.949E+02	6.430E+02	6.430E+02	6.430E+02	6.430E+02
62		Surface area per unit stack length		mm ² /mm	5.720E+01	5.720E+01	5.720E+01	5.720E+01	5.720E+01	5.720E+01	5.663E+01	5.663E+01	5.663E+01	5.663E+01
63		Surface area of the thoria stack		mm ²	8.962E+04	9.115E+04	4.895E+04	7.081E+04	2.861E+04	3.013E+04	8.874E+04	9.025E+04	4.846E+04	6.898E+04
64		Missing-to-total volume ratio (Section 5.2)		none	0.01446	0.01446	0.01446	0.01446	0.01446	0.01446	0.01907	0.01907	0.01907	0.01907
65		Volume of a perfectly cylindrical stack		cm ³	2.069E+02	2.104E+02	1.130E+02	1.635E+02	6.604E+01	6.957E+01	1.751E+02	1.781E+02	9.562E+01	1.361E+02
66		Volume of stack given as-built void fraction		cm ³	2.040E+02	2.075E+02	1.114E+02	1.612E+02	6.512E+01	6.859E+01	1.716E+02	1.746E+02	9.374E+01	1.334E+02
67		Mass of thoria fuel stack		kg	1.995E+00	2.029E+00	1.090E+00	1.576E+00	6.368E-01	6.707E-01	1.683E+00	1.712E+00	9.191E-01	1.308E+00
68		Cladding	1											
69		Cladding length excluding end plug cladding		mm	2.885E+03	2.912E+03	2.885E+03	2.912E+03	2.885E+03	2.912E+03	2.885E+03	2.912E+03	2.885E+03	2.912E+03
70		Inside diameter		mm	1.309E+01	1.309E+01	1.309E+01	1.309E+01	1.309E+01	1.309E+01	1.205E+01	1.205E+01	1.205E+01	1.205E+01
71		Surface area		mm ²	2.503E+05	2.526E+05	2.503E+05	2.526E+05	2.503E+05	2.526E+05	2.307E+05	2.328E+05	2.307E+05	2.328E+05
72		Volume		cm ³	8.927E+01	9.009E+01	8.927E+01	9.009E+01	8.927E+01	9.009E+01	7.740E+01	7.812E+01	7.740E+01	7.812E+01
73		Mass of Zircaloy-4 cladding		kg	5.856E-01	5.910E-01	5.856E-01	5.910E-01	5.856E-01	5.910E-01	5.077E-01	5.124E-01	5.077E-01	5.124E-01
74		Mounting-end plug and stem (Assump. 3.2.4)	1											
75		Volume of main body		cm ³	1.115E+01	5.469E+00	1.115E+01	5.469E+00	1.115E+01	5.469E+00	9.487E+00	4.654E+00	9.487E+00	4.654E+00
76		Volume of stem		cm ³	6.480E+00	6.480E+00	6.664E+00	6.664E+00	6.480E+00	6.480E+00	6.480E+00	6.480E+00	6.664E+00	6.664E+00
77		Surface area (ignore clad thickness)		mm ²	6.360E+03	4.795E+03	6.444E+03	4.879E+03	6.528E+03	4.963E+03	6.072E+03	4.629E+03	6.156E+03	4.713E+03
78		Total volume of plug & stem		cm ³	1.763E+01	1.195E+01	1.781E+01	1.213E+01	1.799E+01	1.232E+01	1.597E+01	1.113E+01	1.615E+01	1.132E+01
79		Mass of mounting-end plug and stem		kg	1.156E-01	7.838E-02	1.168E-01	7.959E-02	1.180E-01	8.079E-02	1.047E-01	7.304E-02	1.059E-01	7.424E-02
80		Free-end closure plug (Assump. 3.2.5)	1											
81		Surface area (ignore clad thickness)		mm ²	1.896E+03	2.243E+03	1.896E+03	2.243E+03	1.896E+03	2.243E+03	1.725E+03	2.046E+03	1.725E+03	2.046E+03
82		Volume of plug		cm ³	5.679E+00	6.941E+00	5.679E+00	6.941E+00	5.679E+00	6.941E+00	4.833E+00	5.907E+00	4.833E+00	5.907E+00
83		Mass of free-end plug		kg	3.725E-02	4.553E-02	3.725E-02	4.553E-02	3.725E-02	4.553E-02	3.170E-02	3.875E-02	3.170E-02	3.875E-02
84		Inconel plenum spring (Assump. 3.2.6)	1											
85		Uncoiled wire length (assuming circular coils)		mm	3.601E+03	3.601E+03	3.601E+03	3.601E+03	3.601E+03	3.601E+03	3.576E+03	3.576E+03	3.576E+03	3.576E+03
86		Surface area (ignore ends)		mm ²	2.049E+04	2.049E+04	2.049E+04	2.049E+04	2.049E+04	2.049E+04	1.872E+04	1.872E+04	1.872E+04	1.872E+04
87		Spring volume		cm ³	9.275E+00	9.275E+00	9.275E+00	9.275E+00	9.275E+00	9.275E+00	7.799E+00	7.799E+00	7.799E+00	7.799E+00
88		Spring mass		kg	7.680E-02	7.680E-02	7.680E-02	7.680E-02	7.680E-02	7.680E-02	6.457E-02	6.457E-02	6.457E-02	6.457E-02
89		Mass of fuel rod (Assump. 3.2.3)		kg	4.166E+00	4.176E+00	4.176E+00	4.192E+00	4.189E+00	4.189E+00	3.538E+00	3.547E+00	3.548E+00	3.552E+00
90		Solid volume of fuel rod		cm ³	4.632E+02	4.631E+02	4.645E+02	4.650E+02	4.653E+02	4.645E+02	3.944E+02	3.943E+02	3.955E+02	3.948E+02
91		Fuel volume (binary & thoria)		cm ³	3.414E+02	3.449E+02	3.425E+02	3.465E+02	3.431E+02	3.458E+02	2.884E+02	2.913E+02	2.893E+02	2.917E+02

A	B	C	D	E	Y	Z	AA	AB	AC	AD	AE	AF	AG	AH
1	Fuel Region (Std.=Standard, Bikt.=Blanket, PF=Power Flattening)				PF Bikt.	PF Bikt.	PF Bikt.				Reflector	Reflector		
2	Rod Type				25	26	27				31	32		
3	Regional Enrichment Zone				High	Medium	High	Blanket Assembly Sums			None	None	Reflector Sums	
4	Rod Mounting Location				Bottom	Top	Bottom	Type I	Type II	Type III	Bottom	Top	Type IV	Type V
5	INPUTS (Ref. 7.4, Tables 3-5, 3-13, 3-14, Sect. 3.1.1.3 except as noted)		Qty	Units										
6	Binary (ThO ₂ & UO ₂) fuel pellet stack		1											
7	Fissile (U ²³³ & U ²³⁵) concentration (Table 3-7)			wt%	2.739	2.009	2.739							
8	Pellet diameter, <i>D</i>			mm	11.9278	11.9253	11.9278				N/A	N/A		
9	Pellet length, <i>l</i>			mm	17.8054	19.9644	17.8054				N/A	N/A		
10	End dish spherical radius, <i>r</i>			mm	29.4894	29.4894	29.4894				N/A	N/A		
11	End dish depth, <i>h</i>			mm	0.3556	0.3556	0.3556				N/A	N/A		
12	Chamfer radial depth, <i>d</i>			mm	0.06096	0.06096	0.06096				N/A	N/A		
13	Chamfer axial width, <i>w</i>			mm	3.81	3.81	3.81				N/A	N/A		
14	Binary pellet stack height (Table 3-7)			mm	2133.6	2133.6	2133.6				N/A	N/A		
15	Percent theoretical density, binary fuel			%	97.906	98.041	97.906				N/A	N/A		
16	Void fraction (Compare Row 54)			none	0.01578	0.01753	0.01578				N/A	N/A		
17	Thoria (ThO ₂ only) fuel pellet stack													
18	Pellet diameter, <i>D</i>			mm	11.9278	11.9278	11.9278				18.83918	18.83918		
19	Pellet length, <i>l</i>			mm	11.3538	11.3538	11.3538				18.8214	18.8214		
20	End dish spherical radius, <i>r</i>			mm	29.4894	29.4894	29.4894				80.0608	80.0608		
21	End dish depth, <i>h</i>			mm	0.3556	0.3556	0.3556				0.3556	0.3556		
22	Chamfer radial depth, <i>d</i>			mm	0.1524	0.1524	0.1524				0	0		
23	Chamfer axial width, <i>w</i>			mm	0.1524	0.1524	0.1524				0	0		
24	Total fuel stack height (Tables 3-7, 3-16, 3-19)			mm	2633.726	2660.396	2633.726				2563.876	2614.676		
25	Thoria percent theoretical density			%	98.057	98.057	98.057				97.282	97.282		
26	Void fraction (Compare Row 64)			none	0.01966	0.01966	0.01966				0.01317	0.01317		
27	Cladding		1											
28	Plenum length (Section 3.1.1.1.2, Tables 3-16, 3-19)			mm	251.46	251.46	251.46				100.457	100.457		
29	Outside diameter (Table 3-8)			mm	13.39596	13.39596	13.39596				21.14042	21.14042		
30	Thickness (Table 3-8)			mm	0.671068	0.671068	0.671068				1.06426	1.06426		
31	Fixed-end plug and stem (Sect. 3.1.1.1.2, Tables 3-6, 3-15, 3-16, 3-20)		1											
32	Diameter of main body (including cladding)			mm	13.39596	13.39596	13.39596				21.14042	21.14042		
33	Length of main body (including cladding)			mm	67.31	33.02	67.31				95.25	53.975		
34	Diameter of mounting stem (max)			mm	8.763	8.763	8.763				8.763	8.763		
35	Length of mounting stem (uncut)			mm	113.538	113.538	116.84				75.692	75.692		
36	Free-end plug (Sect. 3.1.1.1.2, Tables 3-6, 3-15, 3-16, 3-20)		1											
37	Diameter of plug (including cladding)			mm	13.39596	13.39596	13.39596				21.14042	21.14042		
38	Length of plug including hemispherical end			mm	34.29	41.91	34.29				53.975	44.45		
39	Inconel plenum spring (Table 3-9)		1											
40	Number of coils			none	135	135	135				33	33		
41	Wire diameter			mm	1.66624	1.66624	1.66624				2.7686	2.7686		
42	Spring mean diameter			mm	8.4328	8.4328	8.4328				13.3858	13.3858		
43	Number of rods per seed assembly (Table 3-6)			none	0	0	0				0	0		
44	Number of rods per blanket assembly of Type I (Table 3-19)			none	0	0	0	444			0	0		
45	Number of rods per blanket assembly of Type II (Table 3-19)			none	179	8	8		564		0	0		
46	Number of rods per blanket assembly of Type III (Table 3-19)			none	276	8	8			633	0	0		
47	Number of rods per reflector assembly of Type IV (Table 3-19)			none	0	0	0				115	113	228	
48	Number of rods per reflector assembly of Type V (Table 3-19)			none	0	0	0				82	84		166

A	B	C	D	E	Y	Z	AA	AB	AC	AD	AE	AF	AG	AH
1		Fuel Region (Std.=Standard, Blkt.=Blanket, PF=Power Flattening)			PF Blkt.	PF Blkt.	PF Blkt.				Reflector	Reflector		
2		Rod Type			25	26	27				31	32		
3		Regional Enrichment Zone			High	Medium	High				None	None		Reflector Sums
4		Rod Mounting Location			Bottom	Top	Bottom		Blanket Assembly Sums		Bottom	Top		Type IV
49		RESULTS (Assump. 3.2.3, this Calculation)							Type I	Type II	Type III			Type V
50		Binary fuel pellet stack	1											
51		Surface area of a single pellet (Section 5.3)		mm ²	8.855E+02	9.662E+02	8.855E+02				N/A	N/A	N/A	N/A
52		Surface area per unit stack length		mm ² /mm	4.973E+01	4.839E+01	4.973E+01				N/A	N/A	N/A	N/A
53		Surface area of the binary stack (Assump. 3.2.2)		mm ²	1.061E+05	1.033E+05	1.061E+05	3.984E+07	5.105E+07	5.775E+07	N/A	N/A	N/A	N/A
54		Missing-to-total volume ratio (Section 5.2)		none	0.01609	0.01435	0.01609							
55		Volume of a perfectly cylindrical stack		cm ³	2.384E+02	2.383E+02	2.384E+02	9.692E+04	1.193E+05	1.333E+05	N/A	N/A	N/A	N/A
56		Vol. of stack with as-built void fract. (Assump. 3.2.1)		cm ³	2.346E+02	2.341E+02	2.346E+02	9.531E+04	1.173E+05	1.311E+05	N/A	N/A	N/A	N/A
57		Mass of binary fuel stack		kg	2.302E+00	2.299E+00	2.302E+00	9.377E+02	1.153E+03	1.288E+03	N/A	N/A	N/A	N/A
58		Fissile loading		g	6.306E+01	4.619E+01	6.306E+01	1.623E+04	2.501E+04	2.988E+04				
59		Thoria fuel pellet stack												
60		Thoria pellet stack height		mm	5.001E+02	5.268E+02	5.001E+02				2.564E+03	2.615E+03		
61		Surface area of a single pellet (Section 5.3)		mm ²	6.430E+02	6.430E+02	6.430E+02				1.672E+03	1.672E+03		
62		Surface area per unit stack length		mm ² /mm	5.663E+01	5.663E+01	5.663E+01				8.885E+01	8.885E+01		
63		Surface area of the thoria stack		mm ²	2.832E+04	2.983E+04	2.832E+04	2.524E+07	2.847E+07	3.034E+07	2.278E+05	2.323E+05	5.245E+07	3.819E+07
64		Missing-to-total volume ratio (Section 5.2)		none	0.01907	0.01907	0.01907				0.01211	0.01211		
65		Volume of a perfectly cylindrical stack		cm ³	5.588E+01	5.886E+01	5.588E+01	5.828E+04	6.127E+04	6.357E+04	7.147E+02	7.288E+02	1.645E+05	1.198E+05
66		Volume of stack given as-built void fraction		cm ³	5.479E+01	5.771E+01	5.479E+01	5.746E+04	6.027E+04	6.246E+04	7.053E+02	7.192E+02	1.624E+05	1.182E+05
67		Mass of thoria fuel stack		kg	5.372E-01	5.658E-01	5.372E-01	5.619E+02	5.900E+02	6.117E+02	6.860E+00	6.996E+00	1.580E+03	1.150E+03
68		Cladding	1											
69		Cladding length excluding end plug cladding		mm	2.885E+03	2.912E+03	2.885E+03				2.664E+03	2.715E+03		
70		Inside diameter		mm	1.205E+01	1.205E+01	1.205E+01				1.901E+01	1.901E+01		
71		Surface area		mm ²	2.307E+05	2.328E+05	2.307E+05	1.117E+08	1.357E+08	1.501E+08	3.361E+05	3.425E+05	7.735E+07	5.633E+07
72		Volume		cm ³	7.740E+01	7.812E+01	7.740E+01	3.982E+04	4.690E+04	5.135E+04	1.788E+02	1.823E+02	4.116E+04	2.997E+04
73		Mass of Zircaloy-4 cladding		kg	5.077E-01	5.124E-01	5.077E-01	2.612E+02	3.077E+02	3.369E+02	1.173E+00	1.196E+00	2.700E+02	1.966E+02
74		Mounting-end plug and stem (Assump. 3.2.4)	1											
75		Volume of main body		cm ³	9.487E+00	4.654E+00	9.487E+00				3.343E+01	1.895E+01		
76		Volume of stem		cm ³	6.848E+00	6.848E+00	7.047E+00				4.565E+00	4.565E+00		
77		Surface area (ignore clad thickness)		mm ²	6.240E+03	4.797E+03	6.331E+03	2.517E+06	3.267E+06	3.701E+06	9.112E+03	6.371E+03	1.768E+06	1.282E+06
78		Total volume of plug & stem		cm ³	1.633E+01	1.150E+01	1.653E+01	6.655E+03	8.530E+03	9.633E+03	3.800E+01	2.351E+01	7.027E+03	5.091E+03
79		Mass of mounting-end plug and stem		kg	1.072E-01	7.545E-02	1.085E-01	4.366E+01	5.596E+01	6.319E+01	2.493E-01	1.542E-01	4.609E+01	3.340E+01
80		Free-end closure plug (Assump. 3.2.5)	1											
81		Surface area (ignore clad thickness)		mm ²	1.725E+03	2.046E+03	1.725E+03	9.188E+05	1.083E+06	1.184E+06	4.287E+03	3.654E+03	9.059E+05	6.585E+05
82		Volume of plug		cm ³	4.833E+00	5.907E+00	4.833E+00	2.802E+03	3.178E+03	3.427E+03	1.895E+01	1.560E+01	3.942E+03	2.864E+03
83		Mass of free-end plug		kg	3.170E-02	3.875E-02	3.170E-02	1.838E+01	2.085E+01	2.248E+01	1.243E-01	1.024E-01	2.586E+01	1.879E+01
84		Inconel plenum spring (Assump. 3.2.6)	1											
85		Uncoiled wire length (assuming circular coils)		mm	3.576E+03	3.576E+03	3.576E+03				1.388E+03	1.388E+03		
86		Surface area (ignore ends)		mm ²	1.872E+04	1.872E+04	1.872E+04	9.096E+06	1.102E+07	1.218E+07	1.207E+04	1.207E+04	2.752E+06	2.004E+06
87		Spring volume		cm ³	7.799E+00	7.799E+00	7.799E+00	4.118E+03	4.784E+03	5.213E+03	8.354E+00	8.354E+00	1.905E+03	1.387E+03
88		Spring mass		kg	6.457E-02	6.457E-02	6.457E-02	3.410E+01	3.961E+01	4.316E+01	6.917E-02	6.917E-02	1.577E+01	1.148E+01
89		Mass of fuel rod (Assump. 3.2.3)		kg	3.551E+00	3.556E+00	3.552E+00	1.857E+03	2.167E+03	2.365E+03	8.476E+00	8.518E+00	1.937E+03	1.411E+03
90		Solid volume of fuel rod		cm ³	3.958E+02	3.952E+02	3.960E+02	2.062E+05	2.410E+05	2.632E+05	9.494E+02	9.490E+02	2.164E+05	1.576E+05
91		Fuel volume (binary & thoria)		cm ³	2.894E+02	2.918E+02	2.894E+02	1.528E+05	1.776E+05	1.936E+05	7.053E+02	7.192E+02	1.624E+05	1.182E+05

Reference 7.6 is provided to allow the reader to inspect the ordinary Excel formulas that were used for the computations. Table II-1 gives attributes of the electronic file contained in Reference 7.6.

Table II-1. Attributes of the Electronic File Contained on Electronic Media (Ref. 7.6)

Attribute	Value
Electronic medium used to store the file	CD
Industry-standard software under which the file was developed	Microsoft Excel 97 SR-2
Name of the file	KB Volumes & masses for Shippingport LWBR.xls
Date and time the file was last modified	10/08/1999 4:30 PM
Size of the file	119 kB
Names of worksheets (tabs) contained within the file	Material Densities, SNF Can, Assemblies, Rods

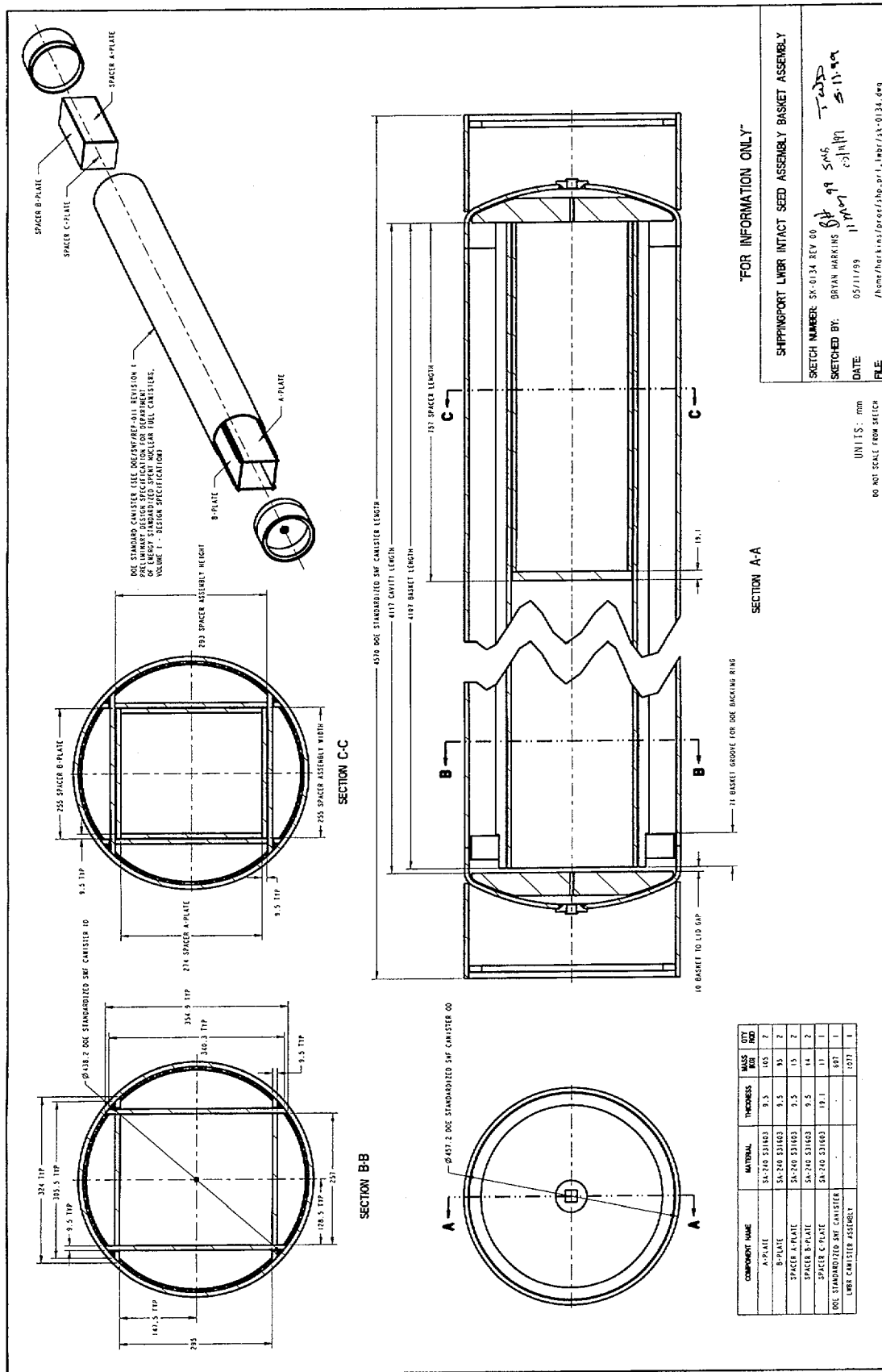

COMPONENT NAME	MATERIAL	THICKNESS	MASS (g)	NET WT (g)
A-PLATE	SA-760 S31603	8.5	165	17
B-PLATE	SA-760 S31603	8.5	35	2
SPACER A-PLATE	SA-760 S31603	9.5	15	2
SPACER B-PLATE	SA-760 S31603	9.5	14	2
DOE STANDARDIZED SNF CANISTER LWBR CANISTER ASSEMBLY			607	1
			1037	1