

## **FINAL REPORT**

**AWARD NUMBER: DE-FG36-05GO85046**

**Period: June 30, 2005 – June 29, 2006**  
**Contract Extension to June 29, 2007**

## **ROBOTICALLY ENHANCED ADVANCED MANUFACTURING CONCEPTS TO OPTIMIZE ENERGY, PRODUCTIVITY, AND ENVIRONMENTAL PERFORMANCE**

### **THE TIMKEN COMPANY – Prime Recipient**

Timken Technology Center and Timken Industrial Bearing Business

Program Manager External Funding: Robert V. Kolarik II (330-471-2378)  
1835 Dueber Avenue, S.W.  
Mail Code: TEC-04  
P.O. Box 6930  
Canton, Ohio 44706-0930

Principal Investigator: Joseph M. Pack (330-471-2650)  
1835 Dueber Avenue, S.W.  
Mail Code: TEC-15  
P.O. Box 6930  
Canton, Ohio 44706-0930

Project Coordinator: Larry L. Keller (330-471-2169)  
1835 Dueber Avenue, S.W.  
Mail Code: TEC-15  
P.O. Box 6930  
Canton, Ohio 44706-0930

**October 31, 2007**

**Prepared for**  
**U.S. DEPARTMENT OF ENERGY**  
**Golden Field Office**  
**1617 Cole Boulevard**  
**Golden, Colorado 80401-3393**

**Project Team Members** (as they existed at the time of the award)

**The Timken Company**

Timken Technology Center and Timken Industrial Bearing Business  
Canton, Ohio

**Project Partners** (Other contact information available upon request)

CAMotion (Computer Automated Motion), Inc.

555 Fourteenth Street, NW, Suite B

Atlanta, GA 30318

[Steve.dickerson@CAMotion.com](mailto:Steve.dickerson@CAMotion.com)

(404)874-0090

Thomas R. Kurfess, Ph.D., P.E.

Director, Carroll A. Campbell Jr. Graduate Engineering Center

Professor and BMW Chair of Manufacturing

Department of Mechanical Engineering

Clemson University

[kurfess@clemson.edu](mailto:kurfess@clemson.edu)

(864) 656-6339

## List of Abbreviations

<b><u>Acronym</u></b>	<b><u>Definition</u></b>
DOE	U.S. Department of Energy
DCAA	Defense Contract Audit Agency
VIPERS	Vendor Inquiry Payment Electronic Reporting System
ASAP	Automated Standard Application for Payments System
EF	The Timken Company's office of External Funding
TMP	Thermo-Mechanical Processing
CTMP	Controlled Thermo-Mechanical Processing
TOM	Tube Optimization Model
REML	Robotically Enhanced Manufacturing Line
ESA	Enhanced Spheroidize Annealing
T-ESA	Thermal Enhanced Spheroidize Annealing
D-ESA	Deformation Enhanced Spheroidize Annealing
DoX	Design of Experiments
DfE	Design for Environment
CI	Continuous Improvement
CNC	Computer Numerical Control
GUI	Graphic User Interface
FE	Finite Element
FD	Finite Difference
CMM	Coordinate Measuring Machine
Btu	British Thermal Units
kVA-hrs	kilo volt ampere-hours
kVA	kilo volt ampere
OD	Outside Diameter
ID	Inside Diameter
2-D	Two-Dimensional
3-D	Three-Dimensional
SFM	Surface Feet per Minute
GPM	Gallons Per Minute
SCFM	Standard Cubic Feet Per Minute
PC	Personal Computer
PLC	Programmable Logic Controller
SCADA	Supervisory Control and Data Acquisition
VLAN	Virtual Local Area Network
HMI	Human Machine Interface
OEE	Overall Equipment Effectiveness
DfSS	Design for Six Sigma
DSE	Design Safety Engineering
VOC	Volatile Organic Compound
RIA	Robotic Industries Association
ANSI	American National Standards Institute
ISO	International Organization for Standardization
IEEE	Institute of Electrical and Electronics Engineers
RPM	Risk Priority Management

# PROJECT OVERVIEW

## EXECUTIVE SUMMARY

### Overview

Early in 2004, the Robotically Enhanced Manufacturing Line (REML) was conceived for the production of small lots of tapered roller bearing races. REML was seen as an opportunity to utilize Timken alloy steel tubing with microstructures optimized for REML processes to reduce **energy** consumption, improve **productivity**, reduce **health** and **safety** risks, and reduce **environmental** impact when compared to conventional, low volume industrial bearing manufacturing. An advanced, low-volume manufacturing line has been constructed at The Timken Company's North Canton, Ohio Technology Center for the low-volume production of industrial bearing races. The line consists of processes for cold working and green machining, for thermal treatment, and for finishing and inspection of the bearing races.

### Background

The Alloy Steel Business of The Timken Company received financial assistance award DE-FC36-99ID13819 from the U.S. Department of Energy in September 1999 for the Controlled Thermo-Mechanical Processing of Tubes and Pipes for Enhanced Manufacturing and Performance (CTMP) project. This project, which concluded in August 2005, began with an R&D phase and progressed to technology demonstration of technology concepts in verification and validation studies.

The premise of the CTMP work was to combine Timken's product understanding with its process expertise and knowledge of metallurgical and deformation fundamentals developed during the project to build a predictive process design capability. The CTMP effort succeeded in delivering a PC-based capability in the Tube Optimization Model (TOM) from which the resultant microstructure of steel tubes was predicted. Process recipes were developed using this predictive capability which achieved targeted energy savings from improved efficiency and reduced scrap and rework. Recipes, as well as recommendations from other studies, were successfully implemented.

Baseline steel grades were selected for characterization during the CTMP project, including a low-carbon bearing grade, an automotive gear steel, and a through-hardened bearing grade. The TOM uses Finite Element or Finite Difference modeling to represent thermal and deformation effects. Results of laboratory experiments and instrumented simulations were in close agreement with microstructures predicted for the selected base grades.

Enhanced Spheroidize Anneal (ESA) processes for high carbon, so-called through-hardened bearing steels, were also evaluated within the CTMP project. One such process, Thermal Enhanced Spheroidize Annealing (T-ESA), was implemented. T-ESA uses special thermal sequencing to reduce post processing heat treatment traditionally used to achieve the desired structure. Timken high carbon, 52100 steel tubes which have been spheroidized annealed are the source material for the REML line. A fully-spheroidized microstructure is essential to the performance of the cold ring rolling process and to other downstream processes in REML. The T-ESA process, and D-ESA when implemented inline, will be applied to REML tubes.

Late in the CTMP project, a task was added with the intention of eventual utilization of CTMP processes to supply material, steel tubes or slugs, which was optimized for the green machining, heat treatment and finish machining of Timken tapered roller bearings. Early in 2004, the Robotically Enhanced Manufacturing Line (REML) was conceived for the production of small lots of tapered roller bearing

rices. In addition to employing CTMP-optimized steel i.e., TOM tube product, REML was seen as an opportunity to reduce energy consumption, improve productivity, reduce health and safety risks, and reduce environmental impact when compared to conventional, low volume bearing manufacturing lines.

In the first phase of the REML project, major assets were acquired for a manufacturing line for follow-on installation, capability studies and optimization. That activity has been documented in the DE-FC36-99ID13819 final report.

In this the second phase of the REML project, most of the major assets have been installed in a manufacturing line arrangement featuring a green cell, a thermal treatment cell and a finishing cell. Most of the secondary and support assets have been acquired and installed. Assets have been integrated with a commercial, machine-tending gantry robot in the thermal treatment cell and with a low-mass, high-speed gantry robot in the finish cell. Capabilities for masterless gauging of product's dimensional and form characteristics were advanced. Trial production runs across the entire REML line have been undertaken. Discrete event simulation modeling has aided in line balancing and reduction of flow time. Energy, productivity and cost, and environmental comparisons to baselines have been made.

### **Energy**

The REML line in its current state of development has been measured to be about 22% (338,000 kVA-hrs) less energy intensive than the baseline conventional low volume line assuming equivalent annual production volume of approximately 51,000 races. The reduction in energy consumption is largely attributable to the energy reduction in the REML thermal treatment cell where the heating devices are energized on demand and are appropriately sized to the heating load of a near single piece flow line. If additional steps such as power factor correction and use of high-efficiency motors were implemented to further reduce energy consumption, it is estimated, but not yet demonstrated, that the REML line would be about 30% less energy intensive than the baseline conventional low volume line assuming equivalent annual production volume.

### **Productivity**

The capital cost of an REML line would be roughly equivalent to the capital cost of a new conventional line. The unit raw material cost for REML (through-hardened bearing steel) is somewhat greater than raw material cost for the conventional line (case-hardened bearing steel). However, changeover time, tooling costs, gauging costs, utilities and energy costs, and manning of REML are less than the conventional line. Since REML supports near single piece flow, work in process inventory and work flow time are much less on the REML line than on the conventional line. REML allows the reduction in inventory of source steel tube sizes from several hundred to a few dozen. As a result, the business model indicates that the costs incurred on the manufacturing line are less with the REML line than with the conventional line for low manufacturing run volumes.

### **Environment**

The REML line, when processing through-hardenable steel, requires far less hydrocarbon and other process gases than the conventional line when processing case hardenable steel. The REML line produces fewer greenhouse gas emissions and less liquid and solid waste materials.

### **Broad Applicability**

The REML benefits will in general be extendible to the manufacture of non-bearing, heat treated and finished machined metal parts in the United States.

## **FOREWORD**

The U.S. Department of Energy (DoE) co-funded the REML project, with Timken agreeing to provide a 50% cost share for this phase. Mr. Dibyajyoti Aichbhaumik was the DoE Project Manager and Ms. Jean M. Siekerka served as the Award Administrator from the Golden Field Office.

The REML project was supported by a capable group of engineers and technicians from the Timken Technology Center. The Timken Company's Industrial Bearing Business and Advanced Process Technology Department of the Timken Technology Center monitored project direction through this phase.

## TABLE OF CONTENTS

Project Overview	
Project Team Members and Project Partners	ii
Additional Project Team Members	iii
List of Abbreviations	iii
Executive Summary	iv
Foreword	vi
Table of Contents	vii
List of Figures	viii
List of Tables	viii
Introduction	
Conventional Manufacturing Practice	1
REML Manufacturing Practice	1
Technical Barriers	2
Analytical Tools	2
Benefits	3
Project Management	4
Task 1 Installation of Major Assets	6
Green Cell	6
Thermal Treatment Cell	8
Finish Cell	12
Task 2 Improvement Estimates	14
Energy Consumption Reduction	14
Productivity Improvement	18
Health and Safety Risk Reduction, Ergonomics Improvement	19
Environmental Impact Reduction	19
Broad Applicability of REML to U.S. Industry	20
Barriers to Line or Cell Deployment	24
Task 3 Secondary and Support Assets	25
Cell and Line Process Control	25
Coordinate Measuring Machine	28
Other Secondary Assets	28
Task 4 Trial Runs of Major Production Assets	29
Through-harden Bearing Races	29
Case-harden Bearing Races	30
Task 5 Robotics Research	30
Low-Mass, High-Speed Robot Development	30
Barriers to Robot Deployment	38
Robotics Roadmapping	39
Task 6 Integration of Major Assets with Robotics	39
Reference List	40

## List of Figures

<u>Number</u>	<u>Caption</u>	<u>Page</u>
0-1	Timken Booth at Department of Energy Showcase	5
1-1	Rolling a Tube Slug into an Expanded Blank	6
1-2	Photograph of the Green Cell	7
1-3	Photograph of the Thermal Treatment Cell	9
1-4	Photograph of the Thermal Treatment Cell	10
1-5	Photograph of the Thermal Treatment Cell	11
1-6	Photograph of the Finish Cell	13
2.1-1	Efficiency and Power Factor of Motors	15
2.1-2	Annual Energy Consumption Comparison	16
2.1-3	Annual Energy Cost Comparison	16
2.2-1	Unit Cost Comparison of Conventional Line and REML Line	18
2.5-1	REML Line Cumulative REML Savings Potential	23
3.1	Photograph of Induction Heating SCADA Station	26
3.2	Process View into Thermal Treatment Cell Flexible Quench Press Asset	27
3.3	Historical Process Data Collection	27
5.1-1	Photograph of Conventional Gantry Robot	31
5.1-2	Photograph of CAMotion Gantry Robot	32
5.1-3	Drawing of CAMotion Gantry Robot	35
5.1-4	Micro-manipulator	36
5.1-5	Fiducial Device	37
5.1-6	Robot Power Consumption Comparison	38

## List of Tables

<u>Number</u>	<u>Title</u>	<u>Page</u>
2.5-1	Breakout of Number of U.S. Companies Which Would be Candidates for Deployment of an REML-Like Thermal Treatment Cell	22
2.5-2	Summary of U.S. Companies Which Would be Candidates for Deployment of an REML-Like Thermal Treatment Cell	23
5.1-1	CAMotion Robot Part Load Repeatability Results	34



## **INTRODUCTION**

### **Conventional Manufacturing Practice**

The vision of The Timken Company is to improve its customers' performance by applying its knowledge of friction management and power transmission. The manufacture of antifriction bearing components by companies in the U.S. bearing industry, including Timken, has typically relied on conventional practices. The general process flow utilizes conventional green machining of conventional metals, conventional modes of heating (furnace) for heat treating, conventional means of finish machining, and conventional machine tending and handling.

The typical features of the baseline manufacture of metal parts which are hardened and finish machined include:

- conventional case hardened steel
- conventional green machining of tubes
- carburizing furnace
- furnace heating for press hardening and furnace temper
- finish machining with multiple, single-function finishing machines
- conventional, mastered, comparative dimensional and form gauging of races
- manual machine tending and conveyor part transfer

### **REML Manufacturing Practice**

Early in 2004, the Robotically Enhanced Manufacturing Line (REML) was conceived for the manufacture of tapered roller bearing races in small annual volumes and in small average lot sizes. Economic, small average lot sizes facilitates make-to-order manufacturing over less desirable bulk manufacturing to replenish inventory in distribution centers.

The features of the REML manufacture of metal parts in small annual volumes and in small average lot sizes which are hardened and precision finish machined include:

- alternative, CTMP-optimized metals
- cold worked expansion of rings or shapes
- CNC green machining
- induction heating for press hardening and induction temper
- finish machining with multi-function finishing machine
- masterless, dimensional and form gauging of races
- automated visual inspection of finished races
- robotic machine tending and robotic part transfer

The Controlled Thermo-Mechanical Processing of Tubes and Pipes for Enhanced Manufacturing and Performance (CTMP) Tube Optimization Model is employed to provide best tube product condition. Cold ring rolling enables a small number of tube slug sizes to be expanded into a large number of sizes of blanks from which bearing races across a large size range can be green machined.

Induction piece-heating processes offer energy savings when compared to conventional gas and electric furnaces that must be run in 24 hours a day, 7 days a week.

Robotic machine tending removes much of the repetitive manual labor and is also a key enabler in implementing alternative heating concepts that can be used on demand. In addition, low-mass robotics offer energy savings compared to conventional robotics.

## **Technical Barriers**

The following were identified as significant barriers to be overcome during this phase of the project:

Achieving an induction heating process and an induction temper process which do not require part-specific tooling yet achieve the required control over temperature uniformity within all races i.e., across full range of diameters, widths, and cross sections.

Sensing and gripping parts which are hot without causing geometric distortion. Optimization of gripper actuation forces.

Minimization of heat transfer from heated product to the grippers and ambient air.

Positioning parts in assets which require high positional accuracies while the assets function in harsh, metal-removal environments.

Integrated system control of the finish cell machine tending robot, which will require sophisticated control of the equipment and devices with input from the control model and sensors.

These hurdles, as well as many others encountered during the project, were solved or overcome during the course of the project.

## **Analytical Tools**

Many of the critical REML processes underwent screening Design of Experiments (DoE) methodology to identify factors that are important to the desired product responses for that process. After those factors were established, the capabilities of the Tube Optimization Model (TOM) could be employed to optimize material conditions for the best overall performance of the REML processes. The TOM will predict material for the best compromise of minimum product distortion during thermal treatment and maximum green and finish machining tool life. The FE modeling (DEFORM<sup>TM</sup>2-D deformation) has been and will be used to predict product microstructure and distortion which may result from cold rolling and thermal treatment as a function of material and metallurgical properties.

The cells of the line and the entire line underwent discrete event simulation modeling using the commercially available WITNESS simulation and optimization software. WITNESS optimizes one or more selected outputs (unit cost, throughput, flow time, buffer capacity, manpower utilization, energy utilization, etc.) as a function of inputs (asset layout, asset changeover and cycle times, buffer capacity, manning, line balancing). Modeling is a valuable tool for asset leader visualization and reaction.

## **Benefits**

REML represents an opportunity to reduce energy consumption, to improve productivity, to reduce health and safety risks, and to reduce environmental impact when compared to conventional, low volume manufacturing of metal parts which are hardened and finish machined.

**Energy Reduction:** On-demand induction heating and induction temper replaces continuously operated, energy-oversized furnace heaters in the thermal treatment cell. The energy goal of the REML line was to demonstrate annual energy consumption reduction of at least 20% compared to the appropriate baseline low-volume industrial bearing line producing comparable volumes of parts. Energy consumption refers to all forms of energy, except human energy, consumed in the manufacture of a baseline part produced in representative annual volumes. The baseline part is the mean energy consumer of all part geometries typically produced.

**Productivity Improvement:** Cold ring rolling technology enables the reduction in inventory of steel tube sizes from several hundred to a few dozen for the intended part size range of REML. CNC machine instructions are coded off-line and downloaded across a network to each asset at the time of part number changeover. Assets utilize flexible or range tooling rather than part number specific tooling which is costly to make, store, and change over. Multi-function finishing processes replace multiple, single-function finishing processes. Robotics replace most of the manual material handling and much of the fixed material handling. Low mass robotics reduce capital cost and save energy as compared to conventional robotics. As a result of these features, change-over times are reduced and unit costs and unit labor content are reduced. Flow time is reduced dramatically. Inventory levels of source steel are dramatically reduced.

**Health and Safety Risk Reduction, Ergonomics Improvement:** Formal Health and Safety Risk Assessments are on-going for each line asset in collaboration with the most current design safety engineering practices. As a result of the robotic machine tending and other forms of automation, ergonomic injuries will be prevented.

**Environmental Impact Reduction:** The REML line requires far less hydrocarbon and other process gases than the conventional line. This in conjunction with employment of Design for the Environment (DfE) methodologies will ensure that the REML line produces fewer greenhouse gas emissions and less liquid and solid waste materials.

The REML benefits will in general be extendible to the manufacture of non-bearing, heat treated and finished machined metal parts in the United States.

## **Project Management**

Project management included the usual work of tracking actual costs and monitoring progress against development deliverables. It involved coordination between team members and Timken's External Funding (EF) Office, compliance with procedure, and preparation of progress reports in DoE's format.

Labor rates were determined by the business group at Timken's Technology Center and have been reviewed by the Defense Contract Audit Agency (DCAA). Labor hours were logged daily and tracked using the commercial package, Planview. Hours were entered by the associates and were verified by the project leader. Timken's normal purchasing systems were used to track the project costs and used as inputs to an expenditure database and other spreadsheets in preparing invoices.

Invoicing was accomplished through on-line DoE's Vendor Inquiry Payment Electronic Reporting System (VIPERS) to the Automated Standard Application for Payments System (ASAP) with the U.S. Treasury Department.

The Timken Company asserted that some of the technical data or computer software to be developed and delivered under the proposed contract may contain restricted or proprietary information or research previously acquired or developed by The Timken Company and would be provided with restrictions on the Government's use, release or disclosure. Any such information or data supplied in connection with the contract was specifically identified with appropriate restrictive legends or markings.

Patent applications pertaining to some current areas of investigation had been filed prior to initiation of the REML project. After the project was initiated, a patent waiver was applied for by Timken and granted by the DoE. Several areas of project investigation may merit protection.

A review process was created at Timken to consider publication requests. Because of commercial considerations, publication generally has been restricted throughout the project. The first subject released for publication was the low-mass, high-speed gantry robot developed for Timken by CAMotion Inc. The capabilities and benefits of that gantry robot were first published and presented as listed below:

- Steve Dickerson, CAMotion, Inc.; Ai-Ping Hu, CAMotion; Inc, Joe Pack, Timken Co. "A Large, High-Speed, Machine-Tending Robot", Cleveland Exposition and Conference Emphasis on Flexible Manufacturing, Cleveland OH, June 7 – 9, 2005

With the approval of the DoE, the energy, environmental and productivity benefits of the REML project were introduced to the public in a presentation made at the Department of Energy Showcase where Timken manned a display booth (Figure 0-1) and presented during a breakout session as listed below:

Joseph M. Pack "Robotically Enhanced Manufacturing Line", Department of Energy Showcase Presentation, Cleveland OH, Sep 28, 2005

Dibyajyoti (Debo) Aichbhaumik, Ph.D., PMP Project Manager for the U.S. Department of Energy conducted a site visit to the REML line at the Timken North Canton, Ohio Technology Center on July 11, 2006.

Timken provided project updates at the U.S. Department of Energy - Energy Efficiency and Renewable Energy Industrial Technologies Program – Sensors and Automation Annual Portfolio Reviews in June 2005, June 2006 and June 2007.



Figure 0-1 Timken Booth at Department of Energy Showcase, Cleveland OH, Sep 28, 2005

## Task 1 Installation of Major Assets

The following assets have been acquired by purchase or transferred from other service and installed in cells in a low-volume manufacturing line configuration.

### Green Cell (Figure 1-2)

#### **Saw**

A CNC band saw cuts Timken steel tubes into slugs. Slugs are washed at the saw to remove chips. Initial blade tests were conducted to select commercial blades (type, pitch, coatings), which offer the most favorable cutting performance (in-specification length and face squareness) and life, and which minimize burrs.

#### **Ring Roller**

The Ring Roller cold rolls a small family of tube slug sizes into a large family of different sizes of rectangular, cross section blanks. See Figure 1-1. A range set of mandrels are used in conjunction with one king roll to achieve the desired expansion. A post-roll wash removes the heavy rolling oil and cools the part. Initial testing has been conducted to obtain a preliminary understanding of the maximum expansion rates of high carbon and low carbon bearing steels and the process sensitivity to incoming variation in length, ID, OD and out-of-round.

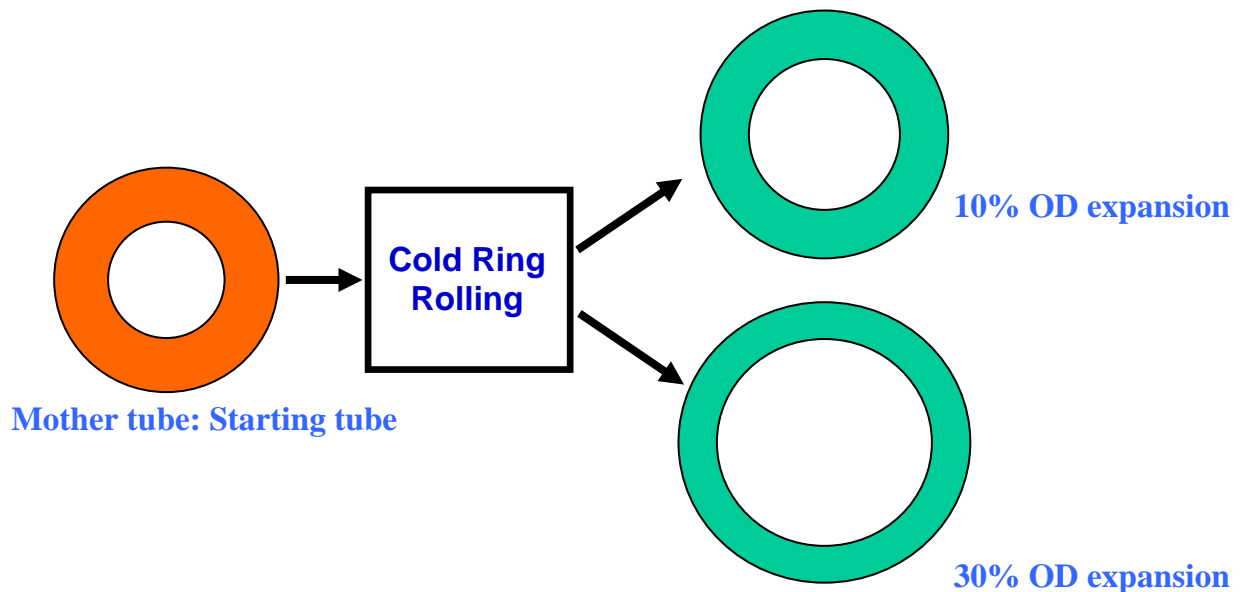

Figure 1-1 Rolling a Tube Slug into an Expanded Blank

#### **Chucker**

A dual-spindle, CNC turning lathe with swing arm robot machines the blanks into green inner and outer tapered roller bearing races. Inner races are called cones, outer races are called cups. Tooling and work holding for the lathe have been designed and fabricated.



Figure 1-2 Photograph of the Green Cell

## Thermal Treatment Cell (Figure 1-3, 1-4, 1-5)

### **Rapid Carburizer**

Process concepts were evaluated for case carburizable grades of bearing steel, but no commercial rapid carburizing system for high carbon steels is presently deemed appropriate for development.

### **Flexible Induction Heater**

An induction coil and power supply heat the cones and cups prior to being loaded into the hardening press. Range work holding for the heater has been designed and fabricated.

### **Flexible Hardening Press**

The press applies a controlled thrust force to the cone or cup which is fixtured between a lower die and an upper die. Quench oil is pumped to the inside and outside of the part according to a prescribed recipe until the part is cooled to a prescribed temperature. A range set of dies are used. The press is equipped with a fire suppression system.

### **Post-Harden Washer**

A pass-through, conveyORIZED aqueous washer provides a secondary quench and removes the quench oil then dries the cone or cup.

### **Flexible Induction Heater for Temper**

An induction coil and power supply heat the cones and cups to a temper temperature. The tempered races air cool.

### **Post Temper Washer**

A pass-through, conveyORIZED aqueous washer provides post-temper quench and dries the cone or cup for downstream CMM gauging of dimensions and geometry.

### **Medium Accuracy Coordinate Measuring Machine**

A commercial, medium accuracy coordinate measuring machine (CMM) measures the diameters, length, and taper angle of cones and cups as they enter, are processed within, and prior to exiting the thermal treatment cell. The temperature control enclosure for the CMM was upgraded for improved cooling capacity and tighter temperature control. Initial testing has been conducted to select optimum scan velocities and point densities. Formal repeatability and reproducibility testing was conducted to confirm the CMM's capability for the required measurements. Timken engineers collaborated with the CMM vendor to design an interface with the thermal treatment cell gantry robot.

### **Conventional Gantry Robot**

An overhead rail-mounted, six-axis, electric servo-driven articulated gantry robot loads and unloads all the assets within the thermal treatment cell. Other features include an underslung configuration for symmetrical work envelope and automatic end of arm tool (gripper) change. Included are a ranged set of grippers for handling hot and / or wet cones and cups and a different set of customized grippers for handling room temperature and clean cones and cups. Timken engineers have undergone detailed training on programming the robotic motion. They have performed simulations to minimize the potential for inadvertent, corner-rounding collisions.



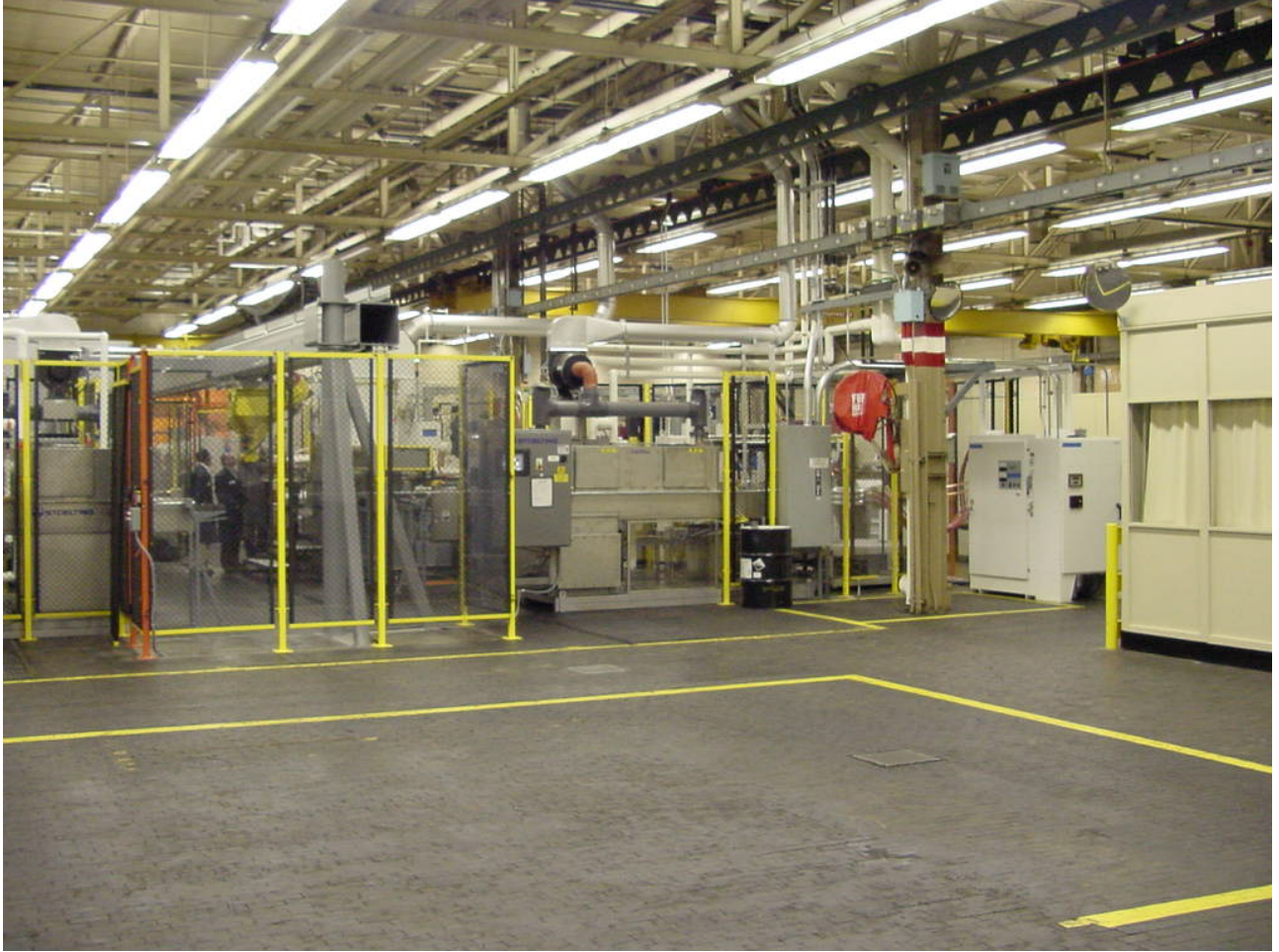

Figure 1-3 Photograph of the Thermal Treatment Cell



Figure 1-4 Photograph of the Thermal Treatment Cell



Figure 1-5 Photograph of the Thermal Treatment Cell

## Finish Cell (Figure 1-6)

### **Flexible Face Finisher**

A CNC machine tool finish machines at least one face of the cone or cup in a single pass.

### **Flexible Finisher**

A CNC machine tool finish machines the IDs and ODs of the cone and cups including the bearing raceways. This machine also superfinishes the raceways of the cones and cups.

### **High Accuracy Flexible Measuring Machine**

A commercial, high accuracy CMM measures the diameters, length, taper angle, profile, and out-of-round of cones and cups as they are processed within and prior to exiting the finishing cell. This measuring machine has been modified to incorporate a rotary axis, Timken proprietary high performance probes, a Timken proprietary automatic part centering device, and Timken proprietary machine control software and measurement analysis software. A custom designed temperature environmental control enclosure precisely regulates the temperature of the measuring machine and the cones and cups being measured. The measurement performance and axes metrology of the measuring machine has been documented.

### **Flexible Surface Inspection**

An end-of-line, camera based system inspects all finished machined surfaces. This system has not yet been developed to the state of performing all the visual quality inspections which a human inspector would perform.

### **De-Magnetization Station**

This station removes residual magnetism from cone or cup prior to finish wash.

### **Finish Washer and Temperature Normalizer**

A custom ultrasonic washer with spin blow off removes contamination on the cone or cup to within corporate dirt count specification and normalizes the cone or cup to 68 F. The cone or cup is prepared for end-of-line surface inspection or high-accuracy dimensional and form measurement.

### **High-Speed, High Positioning Accuracy Gantry Robot**

A low-mass, high-speed, high-placement accuracy gantry robot loads all the assets within the finish cell.

### **Flexible Non Destructive Evaluation**

Eddy current sensors and signal processing software are employed to inspect inside and outside surfaces of cones and cups after finish machining for surface defects (cracks) which may have arisen as a result of cold working or thermal treatment. The unit may also perform a non-destructive, sub-surface hardness or microstructure assurance check.



Figure 1-6 Photograph of the Finish Cell

## Task 2 Improvement Estimates

### Task 2.1 Energy Consumption Reduction

Underlying premises of the REML project are that an REML line will be more energy efficient than conventional, low volume bearing production lines on an equivalent production volume basis and that the REML enablers of energy efficiency would in general be applicable to the manufacture of thermally treated metal parts across the United States.

The energy goal of the REML line is to demonstrate annual energy consumption reduction on an equivalent production volume basis (or on a per unit basis) of 20% compared to an appropriate baseline low-volume conventional industrial bearing line. The features of the baseline were described in the section entitled Conventional Manufacturing Practice. Energy consumption refers to all forms of energy consumed in the manufacture of a baseline part produced in representative annual line volume. A baseline part was selected to correspond to the approximate mean energy consumer of all part geometries capable of being produced on the line. The baseline part was an inner bearing race (cone) of approximately 8 inch outside diameter.

The approach to establishing line annual energy consumption was as follows:

- 1) The energy consumption and power factor of all energy consumers within REML were measured while processing the baseline part and while at idle. Energy forms included electricity, natural gas, process gases, compressed air, and water (chilled, tower, city). Human energy was not included.
- 2) The energy consumption and power factor of all energy consumers of the conventional baseline, low volume line were measured while processing reference-sized parts and while at idle. These measurements were made at a Timken industrial bearing plant in Canton, Ohio.
- 3) Duty cycles (processing versus idle times) were measured for all producing assets of the REML line and the conventional line while producing the baseline part.
- 4) Line annual energy consumptions were computed and comparisons were made assuming equivalent annual line production of approximately 51,000 races per year and using the following conversions and constants:
  - Energy to produce chilled water = 0.4 [kVA-hrs/GPM]
  - Energy to produce compressed air = 0.142 [kVA-hrs/SCFM]
  - Cost of electricity = 0.06 [\$/kVA-hr]

Consumptions were computed as follows:

$$\text{Asset Energy consumed per part} = \Sigma (\text{processing power})(\text{processing time}) + \Sigma (\text{idle power})(\text{idle time})$$

$$\text{Asset Annual Energy Consumption} = (\text{Energy consumed per part})(\text{Annual production volume})$$

$$\text{Line Annual Energy Consumption} = \Sigma \text{Asset Annual Energy Consumptions}$$

5) The potential of additional methods to further reduce energy consumption in REML were evaluated:

- Optimization of inductive heating processes. Additional reduction of the IR losses is feasible. Additional reduction of the flux loss is also likely feasible via alternative coil designs, shielding, etc. Further optimization of the coupling of the coil with the work piece may be possible. However, close coupling in some induction heating processes can result in unacceptable work piece metallurgical properties.
- Power right-sizing of motors. Oversized motors which were supplied with the producing assets could be replaced with high efficiency motors with power ratings appropriate to REML requirements (Figure 2.1-1). Conduct evaluations of improved motor efficiency in conjunction with DoE programs for Advanced Motor Energy Management.

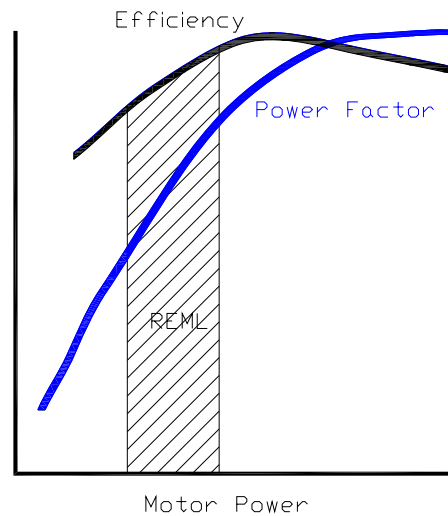

Figure 2.1-1 Efficiency and Power Factor of Motors

- Power factor load controls on high power assets with measured poor power factor. Several of the assets on the REML line are powered by electric induction motors. These motors when energized tend to have a lagging power factor. The windings of the motors act as inductors as seen by the power supply causing the current to lag the voltage. The power utilized by the motor is as little as 40-60% of the supplied power. Capacitors have the opposite effect and can compensate for the inductive motor windings. Systems are available which contribute a variable level of capacitance which is load-specific in order to raise the power factor to 95% to 100%. Some capacitor bank systems also incorporate harmonic filters.
- On-demand energization. Replace continuous with on-demand energization (ventilators, mist collectors, conveyors)

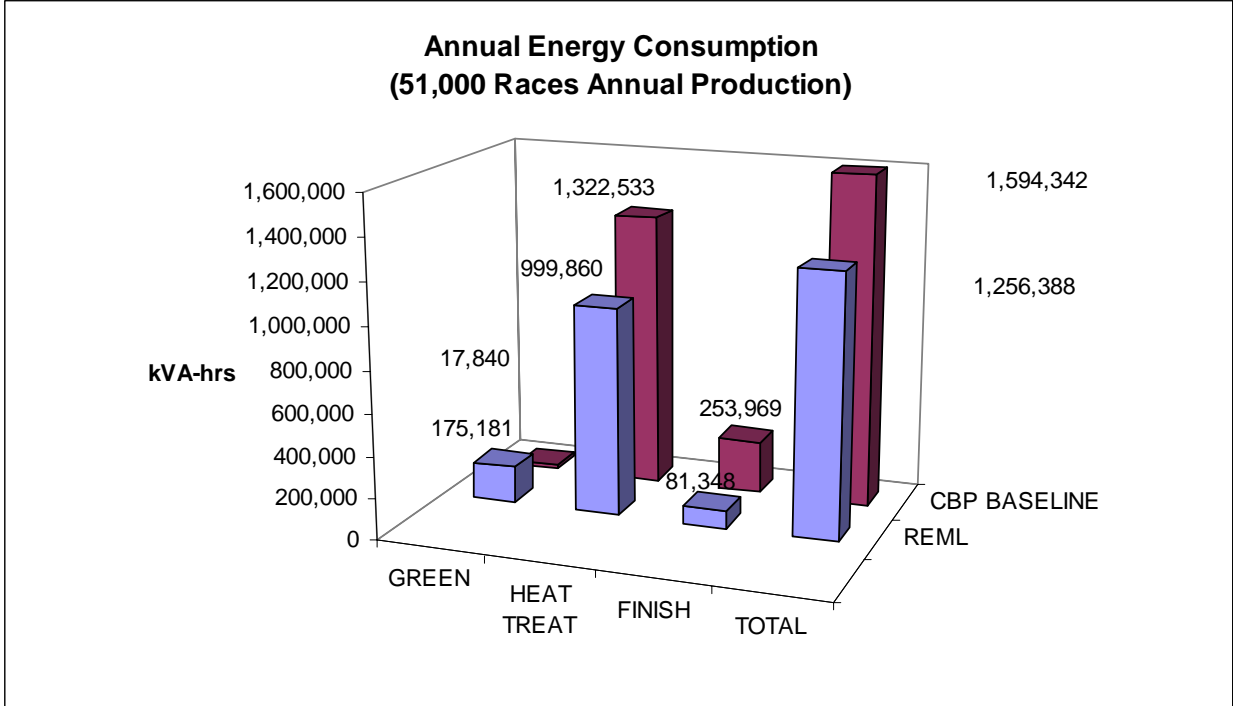

Figure 2.1-2 Annual Energy Consumption Comparison

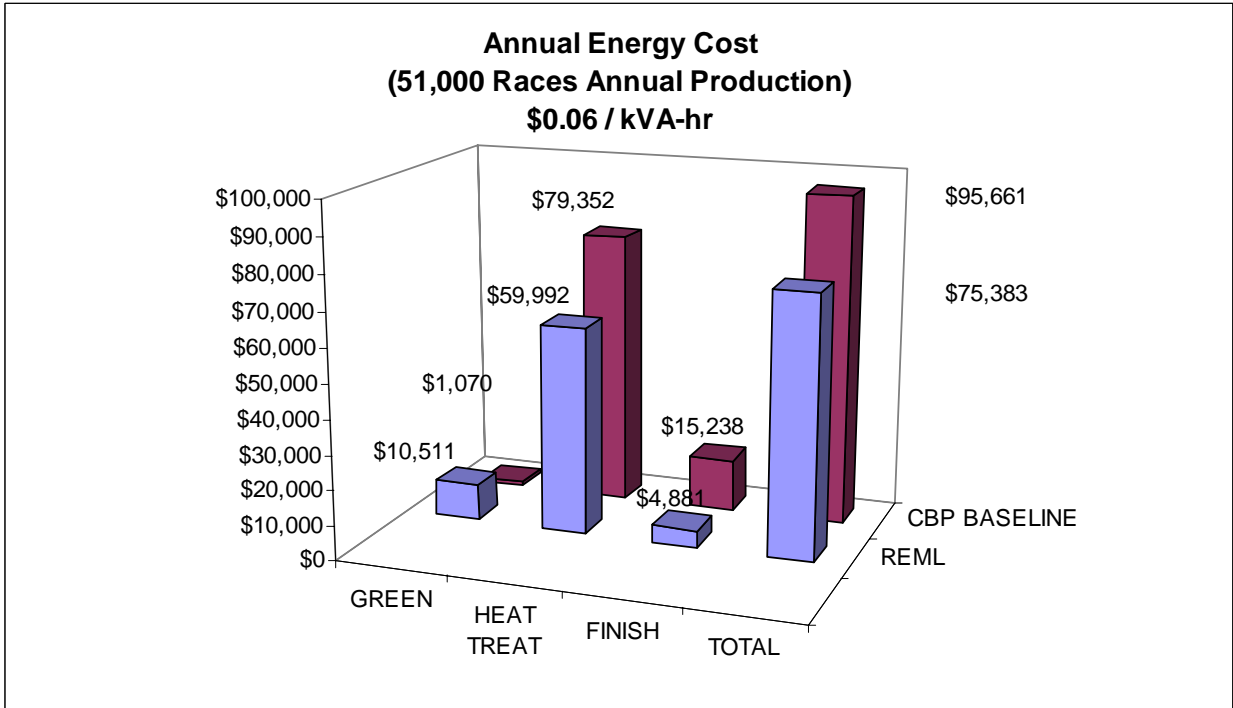

Figure 2.1-3 Annual Energy Cost Comparison



The REML line in its current state of development has been measured to be about 22% less energy intensive than the baseline conventional low volume line assuming equivalent annual production volume (Figure 2.1-2).

The reduction in energy consumption is largely attributable to the energy reduction in the REML thermal treatment cell where the heating devices are energized on demand and are appropriately sized to the heating load of near single piece flow. Because of long warm-up times, the heating furnaces in the conventional line are essentially continuously energized throughout the year except for two one-week planned shutdowns per year and a few days of unplanned shutdown to clear wrecks and perform other unplanned maintenance.

Significant energy consumption occurs when a conventional furnace is taken off line. During a shutdown of a conventional furnace, cooling water is needed during initial cool down. During start up as the furnace is slowly coming up to the processing temperature, generally no work pieces are heated. This may involve several hours to several days depending upon the furnace.

These energy consumptions do not occur when the induction heating processes of the REML Thermal Treatment Cell are off line. No energy is expended during a start up of the induction power supplies. Some water is required during the shut down but far less volume and for far less time. Minimal cooling is needed to prevent damage to the transformers and other critical electrical components.

The DOE maintains a suite of software tools called Process Heating Assessment and Survey Tool (PHAST) accessible at [http://www.oit.doe.gov/bestpractices/software\\_tools.shtml](http://www.oit.doe.gov/bestpractices/software_tools.shtml). Timken thermal treatment engineers utilized the software to perform an energy (heat) balance on the electric rotary furnace of the conventional line. The annual energy consumption estimated with the tool was in close agreement with the estimated annual energy consumption based upon measurement and projection as described previously.

In the context of the low run volume REML manufacturing line, average annual energy consumption of the REML induction heating process for hardening would be much less than an electric rotary furnace as employed in the conventional line for heating for hardening. The ultimate savings will depend upon the final optimized operating parameters of the induction heating process.

If the additional methods described above were implemented to further reduce energy consumption, it is estimated that the REML line would be about 30% less energy intensive than the baseline conventional low volume line assuming equivalent annual production volume.

As the run volume increases, the energy savings would decrease. But increasing run volume significantly would require a significant departure from the near single piece flow intent of the REML line.

Energy efficiency realized in steel tube production was not captured in the energy savings estimate. However, the mother tube concept as described for the green cell would require tubing to be manufactured in significantly larger quantities compared to conventional quantities adequate to fill small orders for part specific tubing. Longer tubing production runs are more energy efficient since they reduce the energy inefficiencies associated with changing over the steel mill furnaces from one tube order to another. The reduction in energy consumption is difficult to estimate accurately but is thought to be substantial.

The 22% energy savings of the REML line compared to the baseline conventional low volume line corresponds to a savings of approximately \$20,300 annually per line assuming a modest energy cost of \$0.06 / kVA-hr (Figure 2.1-3). If the 30% energy savings were realized, a cost savings of \$27,700 annually would result.

### Task 2.2 Productivity Improvement

The capital cost of a new conventional line would be roughly equivalent to the capital cost of the REML line. The unit raw material cost for REML is somewhat greater than raw material cost for the conventional line. However, changeover time, tooling costs, gauging costs, utilities and energy costs, and manning of REML are less than the conventional line.

The business model indicates that the ‘standard cost’ i.e., the cost to manufacture a race on the plant line is significantly less with the REML line than with the conventional line for low manufacturing run volumes. Since REML supports near single piece flow, work in process inventory and work flow time are much less on the REML line than on the conventional line. REML allows the reduction in inventory of source steel tube sizes from several hundred to a few dozen. As a result, the business model indicates that the ‘full factor cost’ would be significantly less with the REML line than with the conventional line for low manufacturing run volumes (Figure 2.2-1).

For high manufacturing run volume, the shorter cycle times associated with the batch processing of the conventional line offset the longer cycle times of the REML line and the unit cost savings of REML diminishes.

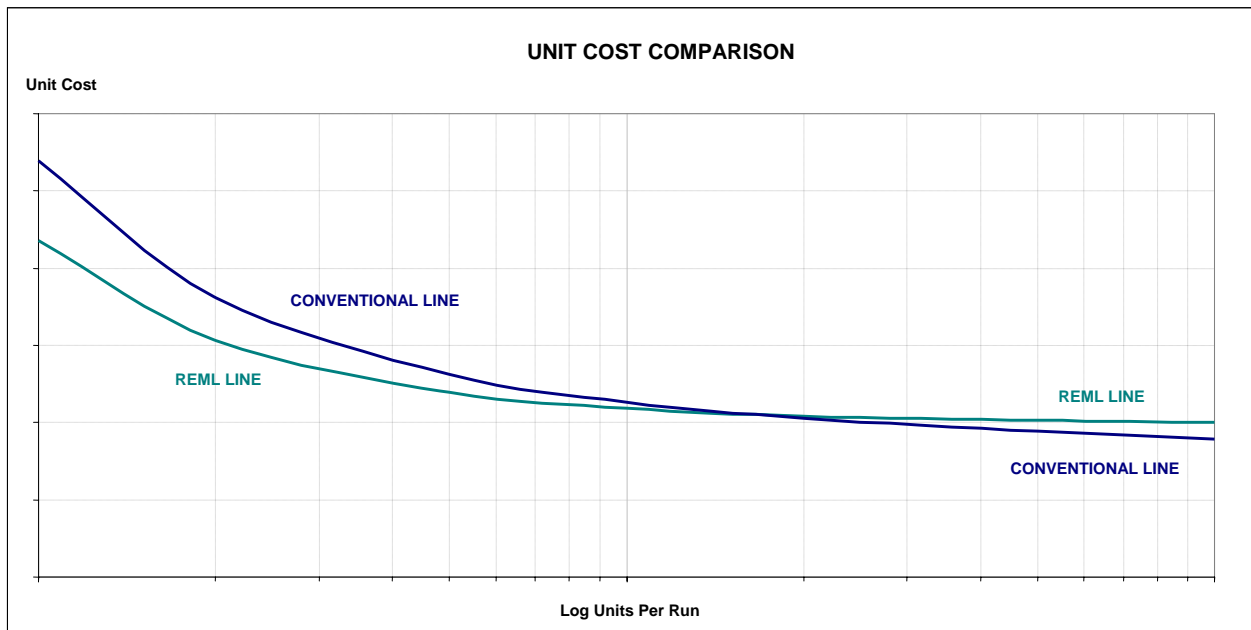

Figure 2.2.-1 Unit Cost Comparison of Conventional Line and REML Line

### **Task 2.3 Health and Safety Risk Reduction, Ergonomics Improvement**

Health and Safety Risk Assessments were completed for each asset by the asset leader and a Timken Health and Safety and Environmental Compliance Analyst. The safety and health risk assessment software program, Design Safety Engineering (DSE) “Design Safe” 2.0 was employed. The status of every asset was reviewed periodically to ensure implementation of corrective measures documented in the safety and health risk assessments for each asset.

The REML line is in compliance with ANSI/RIA R15.06-1999 for robotics safety and the OSHA Subpart O Machine Guarding standard.

The thermal treatment cell induction heating assets meet the applicable IEEE Standards for safety levels with respect to human exposure to electromagnetic fields. Human exposure is minimized by preventing entry into the cell when an induction coil is energized through the use of robot safety fencing. The sound level generated by the operating induction coil requires hearing protection but, is within acceptable limits for a production environment.

Compared to the conventional line, the REML line substantially reduces the risk of ergonomic injuries (musculoskeletal disorders) as a result of the robotic machine tending and other forms of automation which eliminate or reduce the need for human / machine manual interaction, repetitive motion and frequent material handling. It is difficult to accurately quantify the reduction of ergonomic injuries that would result from implementing REML. In a future phase of this program, it may be possible to assess the ergonomic injury risk using a software program, HumanTech Risk Priority Management (RPM), to compare the risk the REML line versus a conventional line.

Automatic CO<sub>2</sub> Fire Protection systems are installed on the thermal treatment and mist collection systems where fire hazards might exist.

### **Task 2.4 Environmental Impact Reduction**

The REML project was selected as the pilot project to initiate a Design for the Environment (DfE) program at the Timken Technology Center. The intent was to integrate DfE practices into the already existing Design for Six Sigma (DfSS) methodologies for process development within The Timken Company. DfE questionnaires were formatted and completed for each asset by the asset leader and a Timken Health and Safety and Environmental Compliance Analyst. The status of every asset was reviewed periodically to minimize hazardous waste and to prevent pollution when compared to the conventional baseline manufacturing line.

The conventional line employs carburizing furnaces wherein methane and methanol are the carburizing gases. REML does not employ a carburizing process. Based on an annual production of approximately 50,000 bearing races and an estimated combustion efficiency of 99.5%, it is estimated that REML would result in an annual reduction of emission of CO<sub>2</sub> into the air of approximately 43,780 lbs and approximately 220 lbs of un-combusted methanol vapors. These are estimates which have not been verified by sampling stack gases.

Conventional lines can also employ gas fired heating furnaces and tempering furnaces which emit volatile organic compounds (VOCs). REML employs electrical induction heating and tempering. Energy and environmental saving estimates in this report assume electrically heated hardening and tempering furnaces on the conventional line.

Conventional heating furnaces require insulating bricks. Periodic re-bricking of a furnace is a slow, tedious process requiring confined-space safety protocols, dust containment, and lock out/tag-out. Spent insulation material is treated as hazardous material when disposed. REML induction heating processes do not require insulating bricks and in general require very little insulation material.

REML employs closed, water-soluble coolant systems for the green machining and finish machining assets. The coolant from this system is changed out every six months and is 100% recycled. The used coolant is transported to the Timken Water Treatment Plant where the water soluble coolant is physically and chemically “broken” into the water phase and oil phase. Both the oil and water are purified for reuse. The purified water is used in our steel plants and the oil is sent to an oil broker for use in fuel blends. It is difficult to quantify, but it is estimated that far less coolant “fall-out” will be experienced with the closed REML systems than with the central coolant systems employed by conventional lines. An estimated 33 gallons of coolant will be lost annually on the REML line due to “fall-out” from the machine & parts and evaporation.

## **2.5 Broad Applicability of REML to U.S. Industry**

The enablers of energy efficiency on the REML line would in general be applicable to the manufacture of many thermally treated and finish machined metal parts across the United States. Inner and outer races of most types of anti-friction bearings (tapered roller bearings, cylindrical roller bearings, spherical roller bearings, and ball bearings) are candidates. Many non-bearing products could be processed with REML cold ring rolling and with REML thermal treatment technologies with energy savings as favorable as that obtained when processing bearing races. Potential non-bearing products include gears, clutch plates, sleeves, spacers, couplings, and most ring-shaped or annular components.

The volume of thermally treated and finish machined annular metal parts produced in the U.S. is not available in the public domain. However, the U.S. Census Bureau does conduct an economic census of manufacturing every five years and reports detailed data. From the 2002 Economic Census, the following products were selected as examples to which the REML thermal treatment technology could apply.

- Ball and Roller Bearing
- Mechanical Power Transmission Equipment
- Motor Vehicle Transmission and Power Train Parts
- Speed Changer, Industrial High-speed Drive, and Gear

The census does not state the volume of specific products manufactured at specific facilities. It does cite the number of companies manufacturing a specific product type with shipments greater than U.S. \$100,000 in each sector. In order to estimate a potential number of REML-like thermal treatment systems that could be deployed across the United States, the following assumptions were made:

- Each potential company would deploy one REML cell, regardless of production volume
- For all product types other than bearing, between 5% and 30% are estimated to be annular
- Refurbishing and assembly companies were excluded
- For the bearing sector, only inner and outer races were considered (mounted and unmounted)
- Non-annular products were not considered since these may be subject to uneven heating and temperature gradients which may result in very detrimental effects on metallurgical properties
- Product specific metallurgical or quality constraints were not considered

Based upon these criteria, there are potentially 246 U.S. companies which would be candidates for deployment of an REML-like thermal treatment cell. See Tables 2.5-1 and 2.5-2.

Table 2.5-1. Breakout of Number of U.S. Companies Which Would be Candidates for Deployment of an REML-Like Thermal Treatment Cell

Product	Product Type	Number of Companies with Shipments of \$100,000 or more	Estimate Percentage of annular components in each product type	Potential Companies for Thermal Treatment Technology
Ball and Roller Bearing	Ball bearings, complete, unmounted	47	100	47
	Tapered roller bearings, unmounted	16	100	16
	Other roller bearings, unmounted	22	100	22
	Mounted bearings	15	100	15
Motor Vehicle Transmission and Power Train Parts	Parts for manual and automatic transmission, new	59	20	11
	Motor vehicle transaxles, new	9	20	1
	Other vehicle drive train components, except wheels and brakes	49	20	9
Mechanical Power Transmission Equipment	Friction-type clutches and brakes	32	10	3
	Gear type flexible couplings	15	30	4
	Sheaves & Pulleys	43	5	2
	Marine propulsion gear transmissions and drives	20	20	4
	Parts for mechanical power transmission equipment	29	15	4
Speed Changers, Industrial High Speed Drive and Gear	Gears, pinions, racks, and worms sold separately	287	30	86
	Worm speed reducers	36	20	7
	Enclosed concentric and parallel (planetary, cycloid, epicyclic, etc.) shaft speed reducers and motor-reducers	23	10	2

	Concentric and parallel (planetary, cycloid, epicyclic, etc.) gearmotors (shaft motor-reducers) less than 1hp (746 watts) to 20hp (14.9kW)	25	15	4
	Planetary, cycloidal, epicyclic, chain and cam reducers and gearmotors	9	20	1
	Replacement parts for concentric and parallel shaft speed reducer, motor-reducer, and gearmotor products, including planetaries, cycloids, and allied products	12	10	1
	Shaft mounted speed reducers and screw conveyor drives	18	5	1
	Offset parallel shaft and right angle speed reducers, except parts	38	10	4
	Replacement parts for offset parallel and right angle speed reducers	13	10	1
	Mechanical adjustable speed drives (nonhydraulic variable speed speed changers), excluding parts	12	10	1
			<b>Total</b>	<b>246</b>

Table 2.5-2. Summary of U.S. Companies Which Would be Candidates for Deployment of an REML-Like Thermal Treatment Cell

Sector	Candidate Companies
Roller and Ball Bearing	100
Motor Vehicle Transmission and Power Train Parts	21
Mechanical Power Transmission Equipment	17
Speed Changers, Industrial High-speed Drive, and Gear	108
<b>Total</b>	<b>246</b>

If the REML line concept were to replace ten of the conventional manufacturing lines (bearing and non-bearing) identified above in 2007 and if ten conventional lines were converted to REML every year through 2030, the cumulative savings across industrial manufacturing sectors in the United States would be substantial. Assuming energy cost of \$0.06 / kVA-hr and a modest 1% increase per year for all forms of energy consumed by industry, cumulative savings would exceed more than \$70,000,000 and more than a year's energy output of a 100 mega Watt power plant. See Figure 2.5-1.

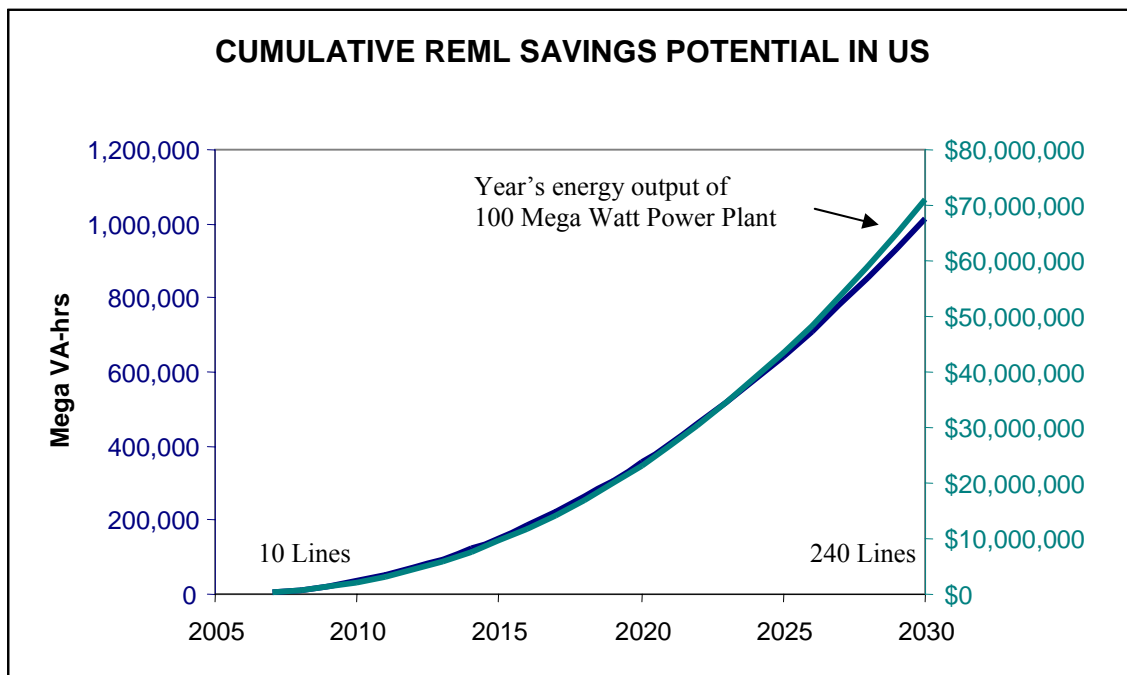

Figure 2.5-1 Cumulative REML Savings Potential

## **2.6 Barriers to Line or Cell Deployment**

The barriers to deployment of the REML concepts to U.S. industry in general terms relate to capital cost, customer approval of new processes and materials, and determining new process parameters for new product geometries.

The technical and business case barriers to deployment of the green, thermal treatment and finish cells within The Timken Company's Industrial Bearing Business are as follows.

### Green Cell

There are few major technical barriers to the deployment of the green cell. Cold ring rolling is a relatively well established process with a variety of industrial applications. However, robustness of the ring rolling equipment while ring rolling hot rolled tubing with varying wall thicknesses may be a concern. The upper limits of expansion in the rolling process and associated potential for material damage have not been investigated.

### Thermal Treatment Cell

The REML Thermal Treatment Cell was to be able to produce hardened and tempered bearing components at a rate which was balanced with the entire line. The greatest technical risk pertains to the induction heating processes. Induction heating is best suited for high volume products wherein tooling costs are distributed over the high volume and accumulated change over time is minimal. Process development for a low volume, through heating applications can require significant quantities of product and time to achieve microstructures that resemble those from a furnace. This is especially difficult to achieve with tapered product geometries like tapered roller bearings. Due to the taper, different portions of bearing component couple better for a given frequency and inductor design. The problem can be further exasperated when the bearing components have protrusions such as those of inner races. To achieve the uniform microstructure produced by a furnace, the induction temperature gradients across the bearing race and across the cross-section need to be minimized. Large temperature gradients can result in high retained austenite (possibly localized), under-heated locations in the case and the core, or large grains. The induction heater in the REML thermal treatment cell may be able to overcome the effect of the geometry sensitivity by slowly heating several components simultaneously. See Task 4.2 Case-harden Bearing Races for additional issues pertaining to the deployment of the induction heating processes.

### Finish Cell

See Task 5.2 Barriers to Robot Deployment for issues pertaining to the deployment of the CAMotion light weight, high speed robot.



## **Task 3 Secondary and Support Assets**

### **Task 3.1 Cell and Line Process Control**

A Supervisory Control and Data Acquisition (SCADA) system was developed for each cell of the REML line to provide a single view into the cell and cell control from a central location in order to enhance cell operational efficiency.

The SCADA system includes hardware and software components. The hardware is a standard personal computer (PC). Each manufacturing asset is assigned an Ethernet port and is connected to the cell SCADA PC over the corporate network. The network is implemented as a virtual local area network (VLAN) for increased performance and security. The software employed is a purchased commercial package with many programmable logic controller (PLC) communication drivers available. The PLC drivers are the main software connection method to the cell assets. Custom software was used to extend the base functionality of the standard package.

The SCADA system is designed to provide rudimentary, remote machine control. The asset modes can be changed from auto to manual. Manual machine functions can be performed without having to physically be at each individual machine control panel.

The SCADA is also designed to interact with three functional categories of asset data: initial data; performance data; and process data. The high mix, low volume production philosophy of REML required initial data recipe management.

Here the initial data settings for each asset based on part geometry are downloaded into each asset for every part change. Cell operators are not be required to enter each parameter at the local human machine interface (HMI). This reduces changeover time. Each asset's parameters can be remotely adjusted for process control during part processing.

Performance data is used to display states, cycle times and fault conditions for each asset on the SCADA PC. This allows cell operators to better assess the condition of the cell during production from the central location. Decisions and cell adjustments can be made quickly in order to maximize overall equipment effectiveness (OEE). OEE data is displayed in real-time and recorded in an historical file for offline analysis.

Process data allows operators to visualize key process parameters during runtime. The data is sensed at the machine level and includes forces, flows, pressures, temperatures, etc. Generally, data that affects the quality outcome of the product is included in this category. Real time visualization promotes rapid response from operators and historical collection allows for run versus designed analysis. This can then be used for improving the process and processing recipes.

The SCADA system is particularly important for process control in the thermal treatment cell. The uniformity of part heating in the induction heater is closely monitored (Figure 3.1). The uniformity of press force and press position are monitored in the quench press (Figure 3.2 and 3.3).

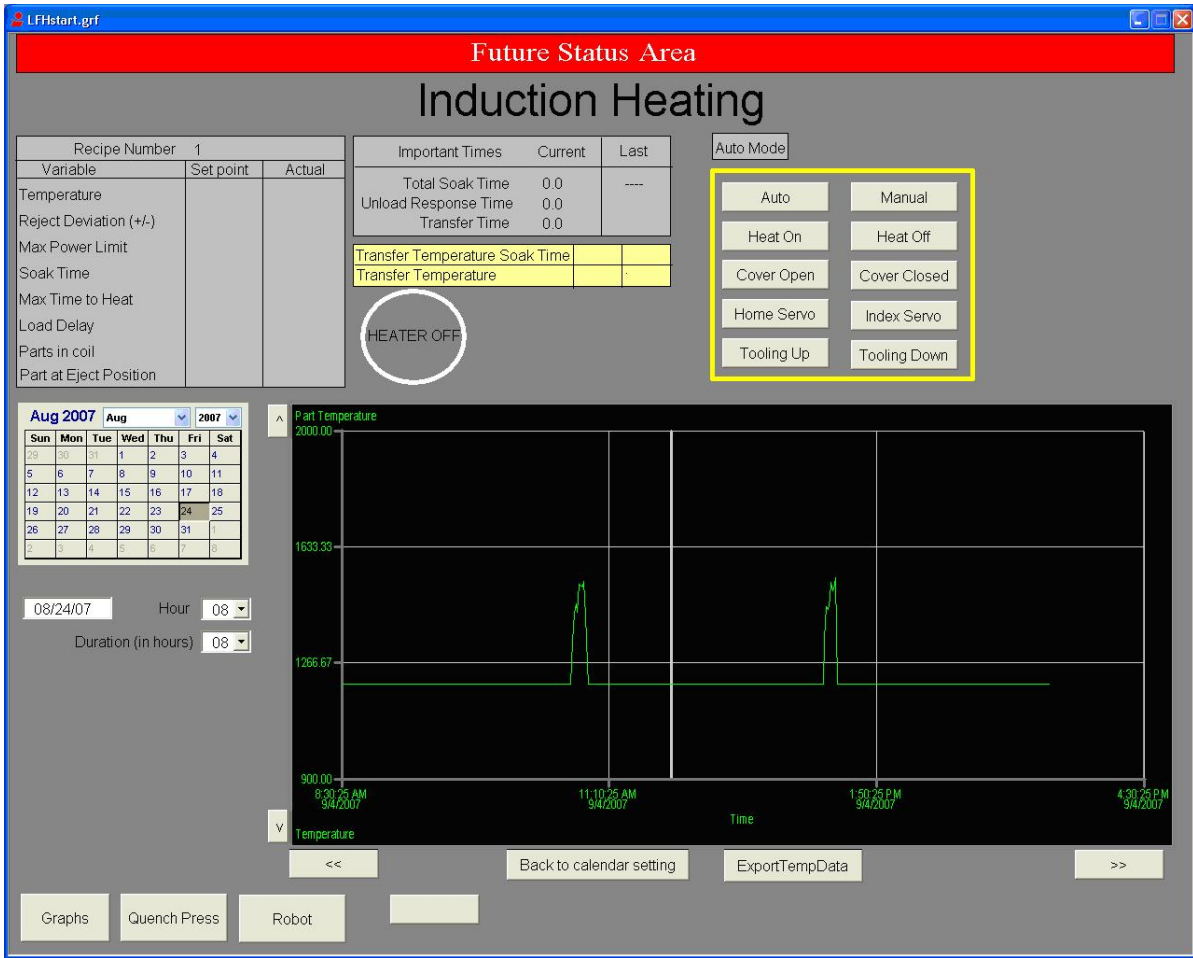

Figure 3.1 Photograph of Induction Heating SCADA Station

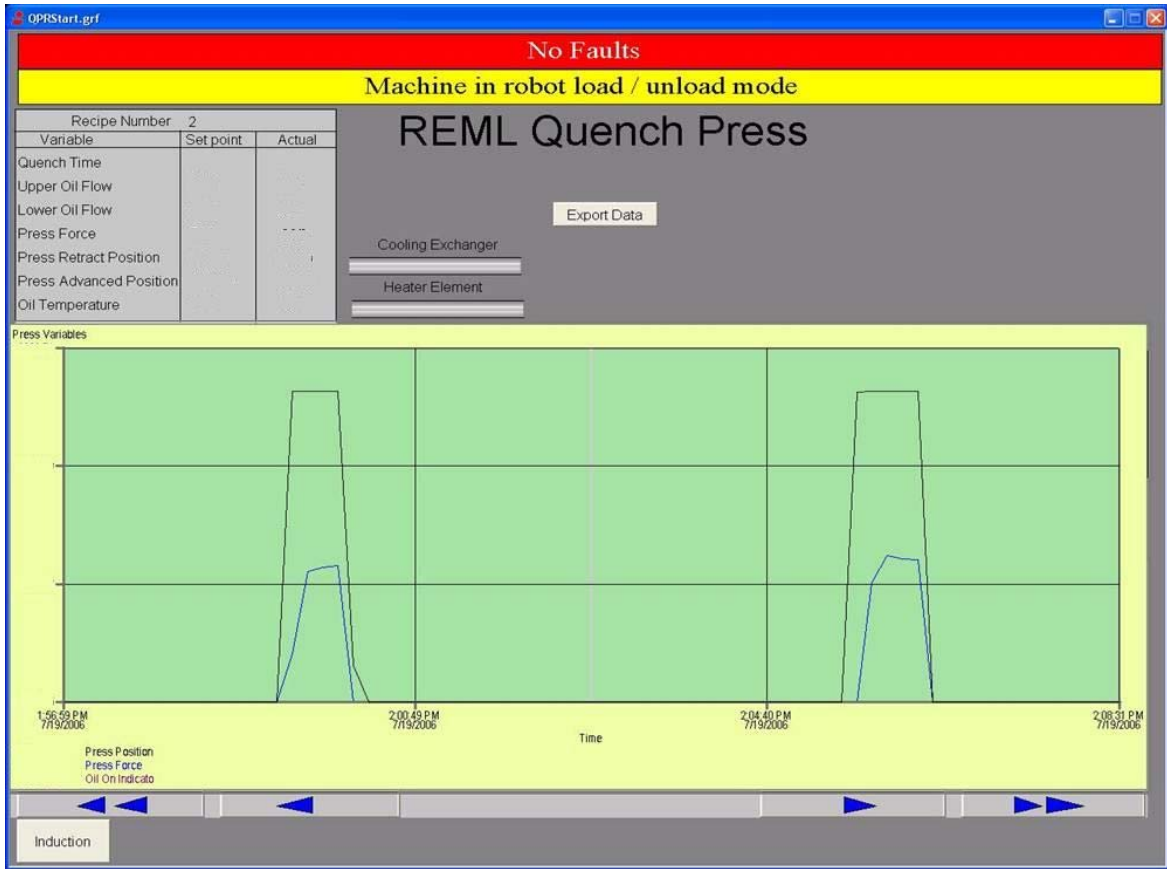

Figure 3.2 Operations Process View into Thermal Treatment Cell Flexible Quench Press Asset

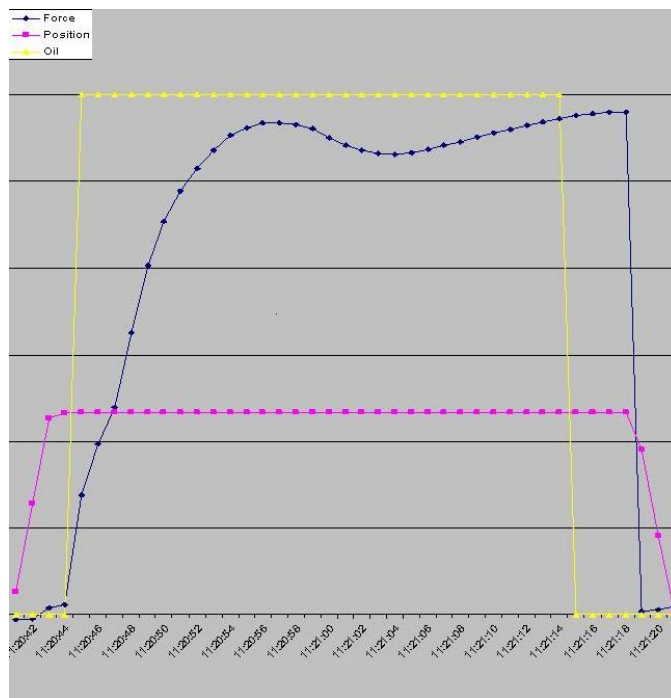

Figure 3.3 Example of Historical Process Data Collection from Thermal Treatment Cell Flexible Quench Press

### **Task 3.2 Coordinate Measuring Machine**

A gauging system which incorporates a commercial Coordinate Measuring Machine (CMM) with robotic material handling was developed for the REML Thermal Treatment Cell. The CMM provides size and form measurements of pre- and post-heat treated parts (cones and cups) as they enter, are processed in, and prior to exiting the thermal treatment cell. The gauging system consists of three main components: automated measurement plan creation, automated measurement plan execution, and automated measurement data analysis.

The automated measurement plan creation component consists of the software and hardware necessary to create and distribute a measurement plan from part size and tolerance information stored in a 3-D CAD model. The tolerance information for each part is placed directly on the model within the CAD environment. These data are then used to plan the CMM measurement strategy (probe paths, clearance planes, probe geometries, etc.) for the part. A measurement plan “template” is created for each part family, allowing for the automation of the creation of measurement plans from the instances of these templates. These measurement plans, just like the part models themselves, are stored in a Product Data Management (PDM) environment, where they can be revision controlled and accessed through the internal network. This solution is fully integrated within the CAD environment, providing direct associativity to the CAD model and tolerance information. Geometric Dimensioning & Tolerancing information is consistent from model-to-model. The resulting gauging plan is complete, ready to execute, and requires no manual programming intervention.

The automated measurement execution component consists of the software and hardware necessary to control the measurement of the parts on the CMM. The SCADA system computer collects and pushes the correct measurement plans for each part onto the CMM’s control computer. A PLC is used with system software to select and execute measurement plans based on the as-processed state of each part, as communicated via the operator control panel on the CMM enclosure or the robotic material handling. The PLC is also responsible for handling all communications between the robotic material handling and the CMM system.

The automated measurement data analysis component consists of the software necessary to collect and report measurement data. It also includes analysis of the data for process capability and control study. Data are stored in formatted text files for viewing in HTML, Microsoft Excel, or as flat text files, which can be pulled by the SCADA system and imported into the line statistical process control (SPC) or analysis tool of choice.

The enabling technology for this gauging system is a medium-accuracy CMM. This machine provides the flexibility to measure parts throughout the program size range, with sufficient accuracy and repeatability necessary for the required part tolerances. The system is capable of full inspection of a part in about 7 minutes, utilizing its scanning capability to collect well over 500 points for each scan of the part surface. These data density allow for more in-depth analysis of part form errors.

### **Task 3.3 Other Secondary Assets**

Material handling for the inlet of the ring roll asset has been purchased, integrated, and installed. The enclosure for the flexible measuring machine for the finish cell has been wired and plumbed. Its environmental control performance has been monitored and meets the design specifications. A secondary hardening asset which was to be utilized to harden cones and cups too small in diameter to be hardened by the flexible hardening press was conceptualized, but was not fabricated. Accessories for the finishing assets have been installed and tested.

## **Task 4 Trial Runs of Major Production Assets**

Individual assets underwent brief runoff trial runs prior to acceptance from the supplier. Once installed in the REML line, more extensive production trial runs were conducted as capability studies of numerous race geometries and material types.

### **Task 4.1 Through-Hardened Bearing Races**

Short-run, trial production runs of races were conducted using through-harden steel. Tubes were sawn into slugs, ring rolled expanded into blanks, green machined into races, induction heated, quenched, furnace tempered, and finish machined. These trial production runs uncovered and continue to uncover issues relating to source material, product metallurgy, product tolerances, asset capability, machine processing instructions and architecture of the manufacturing execution systems, gauging, and in-process transformations.

All major assets in the green cell performed well and demonstrated acceptable process capability. Residual stresses in the rolled rings at times caused moderately high out-of-roundness and size variation after CNC turning. Thermal stress relief was evaluated and stress relieved rings demonstrated minimal geometry variation after CNC turning. However, there was no statistically significant difference between the stress relieved and non-stress relieved groups after heat treatment in the thermal treatment cell. Based on this finding, stress relieving after ring rolling was not incorporated into the green cell.

In the thermal treatment cell, there were four primary metallurgical requirements for the through-hardened bearing races: achieving hardness within the desired range after temper with a  $C_p \geq 1.33$  ; limiting retained austenite to a specified small percentage; achieving microstructure which is acceptably free of free ferrite, bainite and decarburization, and no having cracks. There were core and surface requirements for these parameters. Numerous designs of experiment (DoX) were conducted on the induction heating process for races of various sizes. Generally, austenitizing aim temperature, soak time, and robot transfer speed were used as experimental factors.

In the thermal treatment cell, acceptable microstructure could not be obtained consistently with through-hardened steel bearing races. Marginal or unacceptable levels of retained austenite, detrimental to bearing fatigue life, were observed in some cases. High retained austenite was not due to the induction heating process. It was caused by excessive or inconsistent robot transfer times from the induction heater to the flexible hardening press. If the robot was occupied servicing another asset in the cell, the heated race would soak at target temperature awaiting the robot to arrive at the induction heater. This delay in transfer may also have contributed to high retained austenite. These issues may be overcome by relocating the induction heater closer to the hardening press in order to reduce transfer time and by elevating to highest the priority of the robotic heater to press transfer over other transfers. Instead of heating as many races as could physically be placed within the induction coil, the number of races in the coil was limited to four regardless of race size. This reduced the variation of retained austenite, but did not eliminate it. The DoXs indicated that there is an optimum number of races which should be inside the inductor in order to minimize variation in race microstructure.

All machining assets in the finish cell performed well and demonstrated acceptable process capability. The surface inspection asset and the non-destructive evaluation asset would require additional development prior to deployment to a production line.

## **Task 4.2 Case-Hardened Bearing Races**

In the thermal treatment cell, the primary metallurgical requirements for the case-hardened bearing races were: achieving case hardness and core hardness within the desired range after temper with a  $C_p \geq 1.33$  ; limiting retained austenite to a specified small percentage; achieving case microstructure which is within specification for upper and lower bainite and decarburization, and having no cracks. There were core and surface requirements for these parameters. Numerous designs of experiment (DoX) were conducted on the induction heating process for races of various sizes. Generally, austenitizing aim temperature, soak time, and robot transfer speed were used as experimental factors.

In the thermal treatment cell, acceptable microstructure could be obtained consistently with case-hardened small size and moderate size steel bearing races. Retained austenite was high in some cases, but this not detrimental to the fatigue life of case carburized bearing races. Furthermore, due to the batch processing in carburizing, variation in retained austenite levels from one race to the next was not uncommon. Lower austenitizing soak temperatures were found to minimize austenite variation. All case carburized bearing components processed to date on the line have not exhibited any cracks under magnetic particle inspection. Tempered case and core hardness, whether tempering was by induction or conventional furnace, have been within the acceptable range.

Acceptable microstructure could not be obtained consistently with case-harden large size steel bearing races. Large temperature gradients tend to occur across the cross section of the larger races. The gradients can be minimized by optimum positioning of the race within the induction coil.

## **Task 5 Robotics Research**

### **Task 5.1 Low-Mass, High-Speed Robot Development**

The Timken Company contracted CAMotion, Inc. to design and fabricate a robot for the automated transfer of cones and cups between the assets of the finish cell of the REML line. This effort was undertaken as an example of a new class of high-speed robotic machine which is more energy efficient and less capital intensive than conventional machine tending gantry robots.

The conventional, commercial machine tending gantry robot used in the thermal treatment cell of the REML line (Figure 5.1-1) relies upon structural rigidity in order to 'know' the position of a gripped part. The rigidity of the gantry beam and the column structures which support the gantry and the precise measurement of motor armature positions via rotary axis encoders of the rigid arm links are critical to control of position. Rigid structures are costly to fabricate. The energy consumed by accelerating and decelerating the associated rigid structures is proportional to the mass of those structures.



Figure 5.1-1 Photograph of Conventional Gantry Robot



Figure 5.1-2 Photograph of CAMotion Robot

The CAMotion XYZ robot used in the finish cell (Figure 5.1-2) was less massive and much faster than the commercial machine tending gantry robot used in the thermal treatment cell. It utilizes imprecise and lightweight structures, more like aerospace structures than like rigid machine tool structures.

This robot relies upon sensors and control systems in order to know the position of a gripped part. A typical suite of sensors would include:

1. Motor encoders which provide nearly instantaneous and accurate position of the motor armature relative to motor field (30,000 measurements a second is common).
2. Integrated silicon accelerometers placed near the gripped part that measure the second derivative of the motion of gripped part in inertial space (1,000 samples per second)
3. Machine vision to determine the position of the part in the grippers (50 samples per second)

Typically, a robot's motors are commanded to make moves with an "S shaped" motion profile that are acceleration and velocity limited. These S shaped profiles, if actually followed at the motor, will cause the structure of the machine to deflect and vibrate. This effect can be minimized by making the structure very stiff, and thus heavy, and detuning the Proportional Derivative controller so as to allow the Derivative term to damp the vibrations. The latter approach slows the machine. Thus, most conventional robots are much heavier than necessary for structural strength alone. They are instead designed for minimum deflection.



The practice of minimizing the residual vibration by shaping the S shaped command curve is called command shaping. Essentially, the components of the S shaped curve that are at the natural frequencies of the structure are removed before commanding the motion. For real robotic systems these techniques typically reduce the magnitude of residual vibrations by a factor of 3 or more.

Kalman filters are used to process the sensor signals. Feed-forward learning is employed to teach the servo controllers the load and unload positions. After 5 to 25 trials, the position of the gripped part can be positioned during asset loading with a repeatability of 500 micrometers (0.020 inch).

### **CAMotion Robot Repeatability**

To test the repeatability of the CAMotion robot's part placement capabilities, two tests were performed. The results from each test were recorded and analyzed using the ANSI/RIA R15.05-1 and ISO 9283 standards for robot positioning repeatability. Also, the measured off-center for each load was treated as data in a point cloud. The distances between each point were calculated and the resulting vectors were analyzed to provide an additional measure of repeatability known as Vector  $6\sigma$ .

The first set of tests involved the loading of a part into a scanning coordinate measurement machine. After each load, the off-center of the part was measured. The end-of-arm (EOA) tooling was rigidly attached to the robot via a fixed adapter plate. The robot approached the load locations from two directions along the X-axis and up to 3 directions (above, at, and under the load height) along the Z-axis, for a total of six possible approach vectors. The test was repeated at slower speeds with all other parameters remaining the same.

Based on total part loads, the positional repeatability ranged from 0.048 mm (ANSI) and 0.133 mm (ISO) to 0.216 mm (ANSI) and 0.418 mm (ISO). The minimum values can be ascribed to those part loads where the robot approached the machine from one direction along the X-axis. The higher repeatability values were calculated from load data from all approach directions.

This set of tests was designed to test the capability of the robot's macro axes and the effects of robot speed on part placement repeatability. The results from the first test show that the speed of the robot directly affects the repeatability of the robot. By reducing the speed of the robot for the motions into and out of the machine by nearly half, the magnitude of the repeatability was reduced by almost 50%. It was also clear that the direction from which the robot approaches the machine has a significant effect on the overall repeatability of the robot, increasing the magnitude of the repeatability by a factor of 2.

The second set of tests involved loading a part into a finishing machine. After each load, an LVDT was used to measure the magnitude of the off-center of the part. The end-of-arm (EOA) tooling was attached to the robot using the flexible, micro-motion assembly. A camera mounted to the micro-motion assembly was used to position the robot relative to a fixed array of LED's (fiducial) mounted on the machine. The robot approached the load location from only one direction along the X- and Z-axes. Also, integral gain values were used for the macro axes controls to increase the accuracy of the robot motions.

Based on 67 total part loads, the positional repeatability ranged from 0.086 mm (ANSI) and 0.254 mm (ISO) to 0.12 mm (ANSI) and 0.346 mm (ISO). The minimum values were from the 33 part loads that relied on the LED array for positioning. The maximum values were from the 34 part loads that did not use the LED array for positioning.

This set of tests was designed to determine the effect of the fiducial and integral gains on the part load repeatability. The results show that there is an improvement in overall repeatability, on the order of around 30 micrometers. It can be concluded that the use of the fiducial does not provide a significant

improvement to the part load repeatability over that which is already gained by using integral control on the major axes.

Overall, the data shows that the speed of the robot motions has the greatest effect on the part placement repeatability. Although part placement repeatability is outside of the +/- 20 micrometer range expected with the fiducial, it is well below the +/- 500 micrometers expected of the macro axes motors acting alone.

**Part Load Repeatability Test Results (mm)**

<b><i>Test Description</i></b>	<b><i>Number of Trials</i></b>	<b><i>ANSI/RIA R15.05-1</i></b>	<b><i>ISO 9283</i></b>	<b><i>Vector 6<math>\sigma</math></i></b>
Rigid Tooling, No Fiducial, Approach from +/- X, 90% of Full-Speed for Major Motions, 65% for Motions into the Asset, No Integral Gain	52	0.215671336	0.417977705	0.994403898
Rigid Tooling, No Fiducial, Approach from -X, 90% of Full-Speed for Major Motions, 65% for Motions into the Asset, No Integral Gain	24	0.094080684	0.184939841	0.396554697
Rigid Tooling, No Fiducial, Approach from + X, 90% of Full-Speed for Major Motions, 65% for Motions into the Asset, No Integral Gain	28	0.092998319	0.230487039	0.407849612
Rigid Tooling, No Fiducial, Approach from +/- X, 65% of Full-Speed for Major Motions, 35% for Motions into the Asset, No Integral Gain	80	0.108744582	0.25053124	0.485286483
Rigid Tooling, No Fiducial, Approach from -X, 65% of Full-Speed for Major Motions, 35% for Motions into the Asset, No Integral Gain	41	0.087169045	0.254625064	0.462086186
Rigid Tooling, No Fiducial, Approach from +X, 65% of Full-Speed for Major Motions, 35% for Motions into the Asset, No Integral Gain	39	0.048479979	0.133034187	0.227635967
Compliant Tooling, With and Without Fiducial, Approach from -X, 35% of Full-Speed for Major Motions, 35% for Motions into the Asset, X- and Y-Axis Integral Gains	67	0.110011368	0.316213049	0.563537343
Compliant Tooling, With Fiducial, Approach from -X, 35% of Full-Speed for Major Motions, 35% for Motions into the Asset, X- and Y-Axis Integral Gains	33	0.08649315	0.253851368	0.45273089
Compliant Tooling, No Fiducial, Approach from -X, 35% of Full-Speed for Major Motions, 35% for Motions into the Asset, X- and Y-Axis Integral Gains	34	0.119619169	0.345523715	0.63488519

Table 5.1-1 CAMotion Robot Part Load Repeatability Results

The CAMotion XYZ robot transfers parts rapidly and accurately from one asset to another in the finish cell. The fundamental motions are horizontal in and out of discrete stations, the Y direction, and long horizontal motions between machines, the X direction. The vertical axis, Z, allows the part heights and asset loading elevations to vary (Figure 5.1-3).

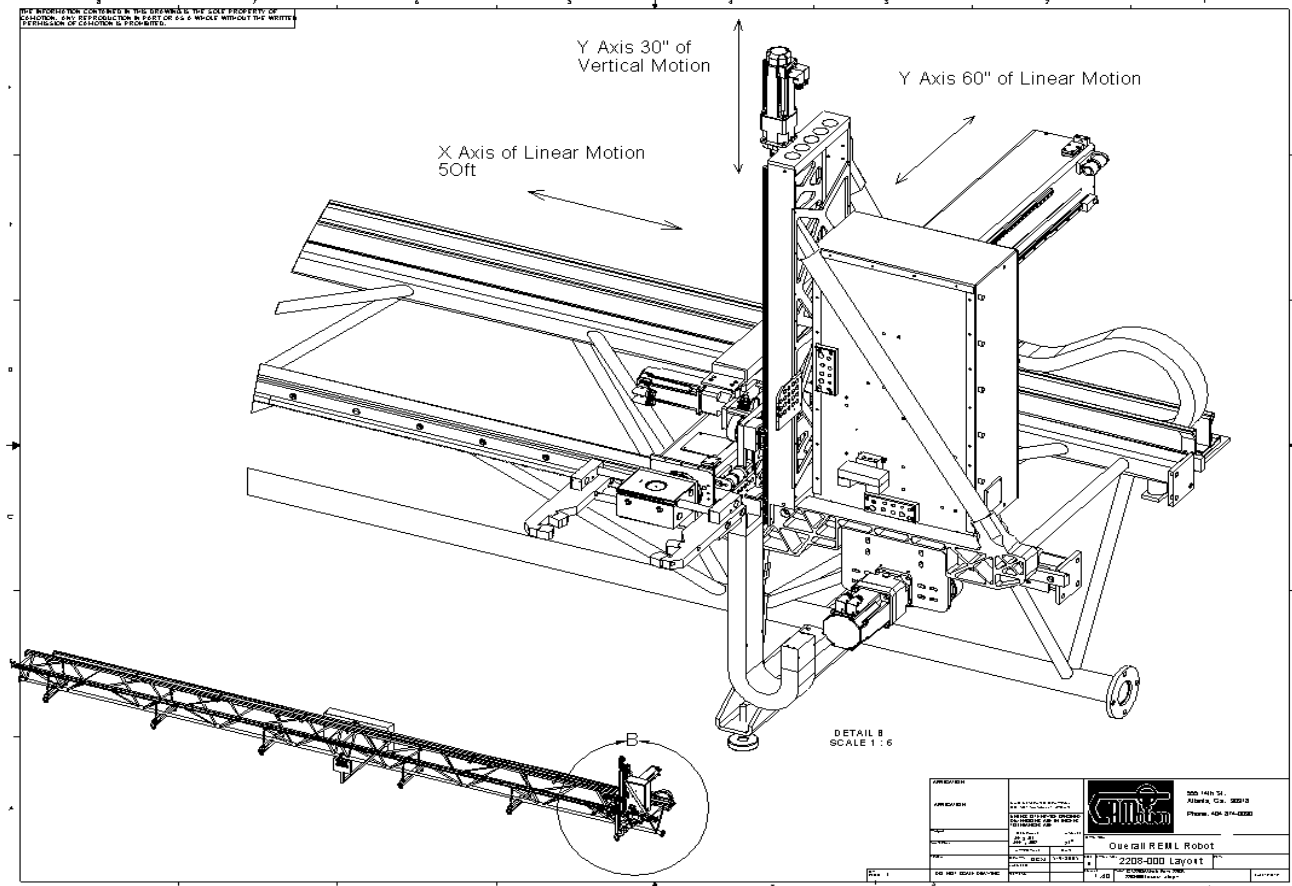

Figure 5.1-3 Drawing of the CAMotion Robot

The machine is based on a triangular space frame approximately 50 feet long. A traveling head is also a space structure, essentially a tetrahedron that moves on the X frame. The Y beam that moves in and out with respect to the traveling head which is a 7-inch square, carbon fiber reinforced tube. All of these structures are designed to minimize the weight. The weight reduction is important primarily for reducing the power consumption of the drives and cost.

The bearing systems are designed to minimize the required precision in aligning bearing tracks.

The drives are all permanent magnet servomotors with gear heads.

An end-of-arm micro-drive mechanism with small servo drives is integrated with the end-of-arm tooling. The micro-manipulator (Figure 5.1-4) is employed to micro-position the gripped part in the X, Y, and pitch degrees-of-freedom. A vision camera is attached to the micro-manipulator, so that as the micro-

motions are made, the camera moves. The camera views a fiducial (Figure 5.1-5) mounted in the asset being loaded. This fiducial is only necessary for loading those assets that have extremely high placement accuracy requirements. It has a pattern of circles that are illuminated by LEDs in the device. The gripped part can be positioned during asset loading with a repeatability of 20 micrometers (0.0008 inch) with use of the micro-manipulator with vision referenced to fiducials.

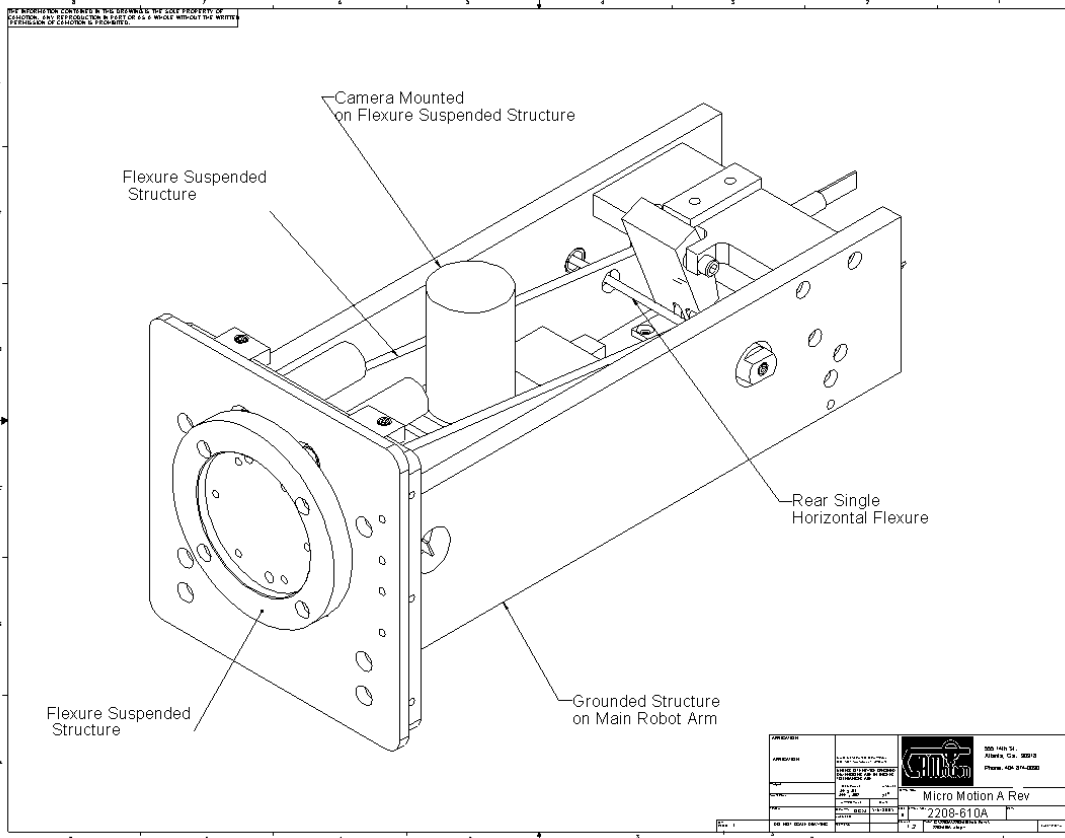

Figure 5.1-4 Micro-manipulator

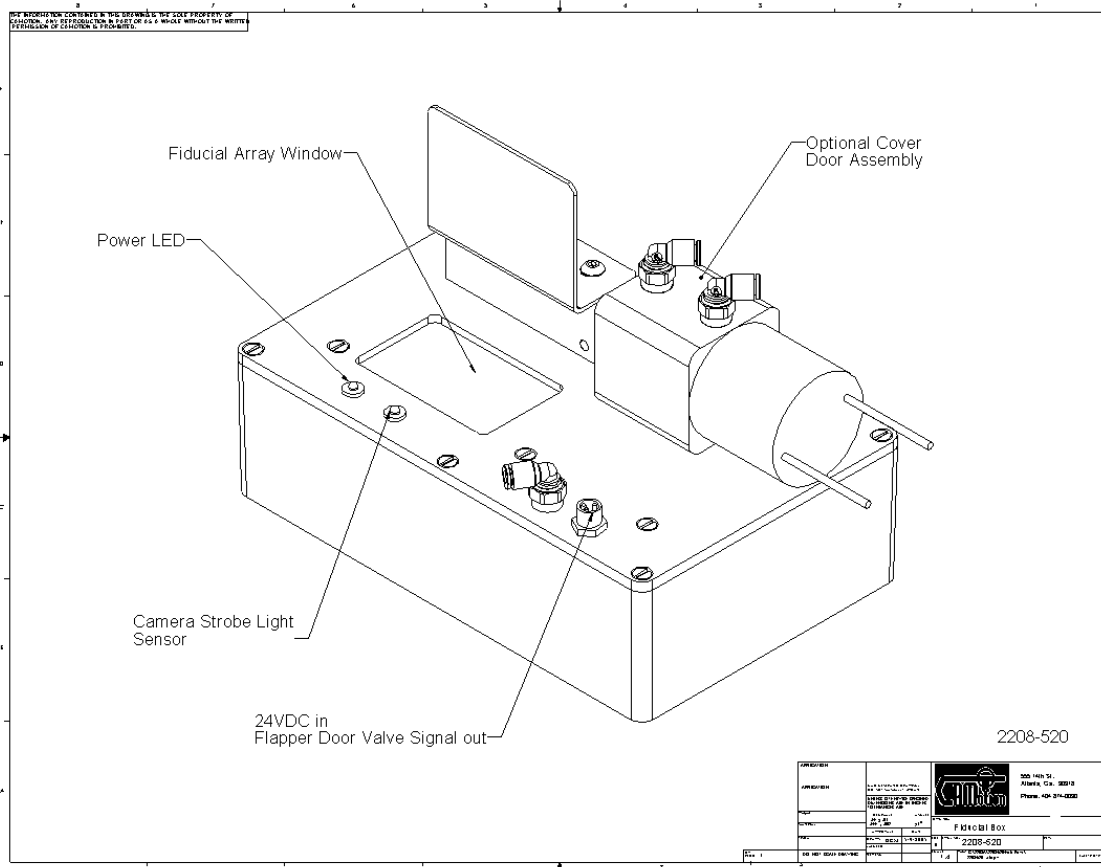

Figure 5.1-5 Fiducial Device

One objective of this machine was a reduction in operating power consumption compared to that required for conventional gantry robots. In this case, the total mass that moves during motions is included in the traveling head. This head weighs approximately 100 Kg for a payload of 50 Kg. Such a lightweight design was achieved by using the efficient tetrahedron shape. Because of the long travel, the motor amps and closed loop controllers are carried with the traveling head. This leads to approximately one-third of the weight in structural elements, one-third in motors with drives, and one third in electronics.

The operating power consumption of the CAMotion gantry robot is about one-half that of the conventional gantry robot when executing similar travels along the gantry axis (Figure 5.1-6). The plot compares measured power consumptions of each robot undergoing the following motions: ‘S’ curve accelerated from rest to a maximum velocity of 2 meters / second then ‘S’ curve decelerated to rest at a location 10 meters away; pause for approximately 1 second; ‘S’ curve accelerated from rest to a maximum velocity of 2 meters / second then ‘S’ curve decelerated to rest back to the starting location. Since the time spans of the motions are approximately equivalent for the two robots, the energy consumption of the CAMotion gantry robot is also about one-half that of the conventional gantry robot when executing similar travels along the gantry axis. When the CAMotion robot executes a 10 meter travel and return while reaching its maximum velocity of about 3.2 meters / second, its energy consumption is approximately the same as when the maneuver is executed at 2 meters / second because the time span is reduced.

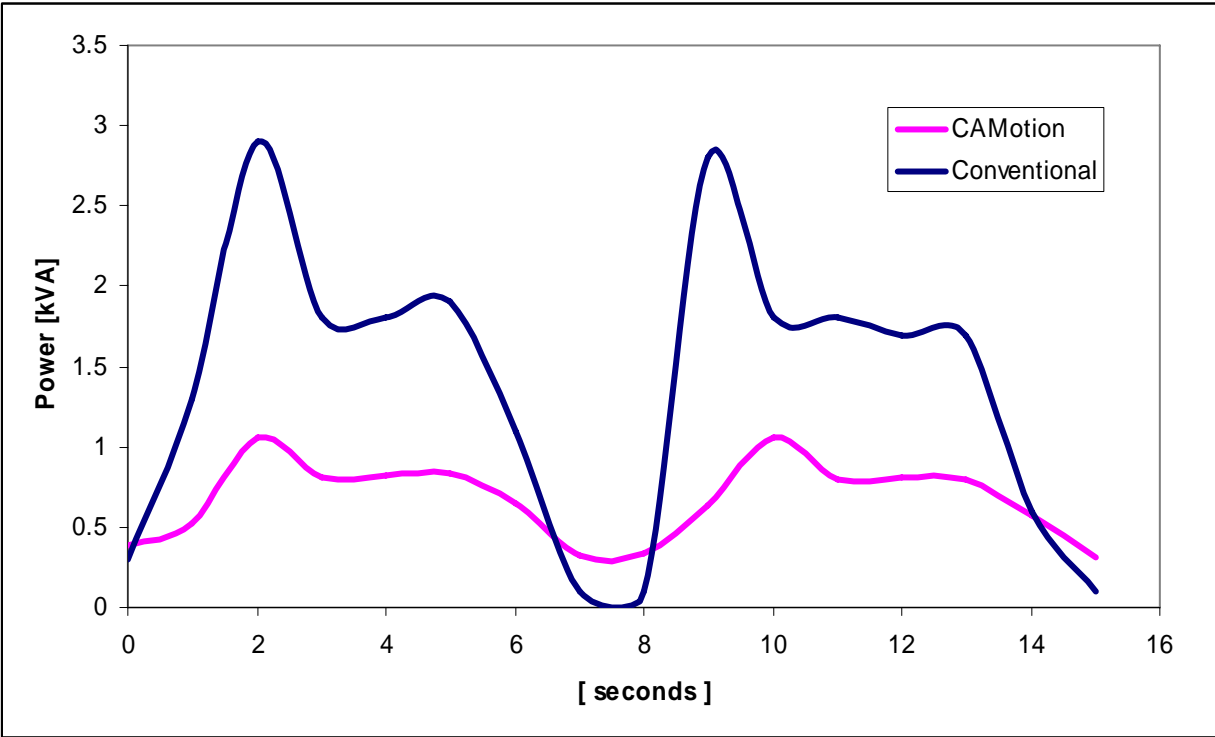

Figure 5.1-6 Power Consumption Comparison

In addition to the reduced power required to operate the robot, the reduction in structural material, such as the main beam, results in reduced energy consumption during fabrication as well.

### Task 5.2 Barriers to Robot Deployment

The CAMotion robot met the technical expectations of the project. It was capable of automated transfer of cones and cups between the assets of the finish cell of the REML line at the expected high velocities and it loaded parts to assets within the specified placement positional accuracy. It was tested to be more energy efficient and, if manufactured in quantity, would be less capital intensive than conventional machine tending gantry robots.

The Timken Company Industrial Bearing Business did not elect to deploy this or other similar gantry robots in a finishing cell of a bearing manufacturing line at the time of this reporting. The floor space occupied by the robot and its restricted safety zone is extensive. Fixed material handling such as conveyors, elevators, pick and place loaders occupy far less plant floor space and much of the fixed handling can be located overtop the finish cell assets.

Long-term technical support and operational reliability of a sophisticated machine so dependent upon multiple servo motors, encoders and scales, sensors, control software, and et cetera are also a concern. A proven track record of uptime in conjunction with a preventative maintenance and monitoring program in a production environment needs to be established.

Automated loading and unloading of parts reduces, but does not eliminate the need for human operator interaction with the finish cell assets. Operators clear chip and swarf accumulations on the chucks and tooling of the face finisher and the flexible finisher after part unloads. They monitor tooling condition and machining anomalies. These tasks historically have proven very difficult to automate with the required levels of reliability.

The prevailing perception of manufacturing operation's personnel is that the potential labor reduction and ergonomic benefits of the automated machine tending capabilities of the gantry robot are not sufficient incentive to deploy the gantry robot in a finishing cell of a bearing manufacturing line.

The low mass high speed gantry robot which was installed and evaluated in the REML finish cell was removed from the cell and returned to CAMotion. The supplier reports that as a direct result of the REML project, large palletizing robots have been engineered and installed in U.S. industry. These light weight robots perform very high speed motions with less energy consumption than conventional robots

### **Task 5.3 Robotics Roadmapping**

Lawrence C. Boyd Jr., Director of Core Programs for Energy Industries of Ohio coordinated activities performed by the offices of Energy Industries of Ohio, Timken Technology Center, Energetics, Inc and Meeting Management Services. These activities resulted in a one-day robotics technologies roadmapping workshop conducted in Baltimore on June 29, 2006. The EIO identified and secured the participation of individuals from academia, federal laboratories, robotic hardware and software suppliers, the user community, the U.S. Department of Energy Industrial Technology Program, and The Timken Company.

On July 18, 2006 Energetics Inc. issued a report of preliminary results from the workshop to workshop participants. The report included discussion of Future Trends Impacting Use of Robotics, Barriers and Challenges to the Use of Robotics, and Technical and Non-Technical Activities to Promote Robotics. Workshop participants commented on the preliminary report and the final report was issued in December, 2006.

The "Robotics in Manufacturing Technology Roadmap" is available online from the U.S. Department of Energy's Energy Efficiency and Renewable Energy website  
[http://www.eere.energy.gov/industry/sensors\\_automation/news\\_detail.html/news\\_id=10633](http://www.eere.energy.gov/industry/sensors_automation/news_detail.html/news_id=10633)

### **Task 6 Integration of Major Assets with Robotics**

Physical pick stations have been incorporated into the thermal treatment cell washers and conveyors for robotic unloading of parts from these assets.

The I/O hardware was purchased and installed for the gantry robot which loads the assets in the finish cell.

Additional hardware, which has been purchased to upgrade the discrete digital communications between the thermal treatment cell's machine-tending robot and the cell's CMM, is being installed.

## REFERENCES

### Introduction:

Robert V. Kolarik, The Timken Company “Controlled Thermo-Mechanical Processing of Tubes and Pipes for Enhanced Manufacturing and Performance (CTMP)” Department of Energy Contract DE-FC36-99ID13819

U.S. Department of Energy - Energy Efficiency and Renewable Energy  
Industrial Technologies Program – Sensors and Automation 2005 Annual Portfolio Review  
[http://www1.eere.energy.gov/industry/sensors\\_automation/meetings\\_0605.html](http://www1.eere.energy.gov/industry/sensors_automation/meetings_0605.html)

U.S. Department of Energy - Energy Efficiency and Renewable Energy  
Industrial Technologies Program – Sensors and Automation 2006 Annual Portfolio Review  
[http://www1.eere.energy.gov/industry/sensors\\_automation/meetings\\_0606.html](http://www1.eere.energy.gov/industry/sensors_automation/meetings_0606.html)

U.S. Department of Energy - Energy Efficiency and Renewable Energy  
Industrial Technologies Program – Sensors and Automation 2007 Annual Portfolio Review  
[http://www1.eere.energy.gov/industry/sensors\\_automation/meetings\\_0607.html](http://www1.eere.energy.gov/industry/sensors_automation/meetings_0607.html)

### Task 2.1:

U.S. Department of Energy suite of software tools called Process Heating Assessment and Survey Tool (PHAST) accessible at [http://www.oit.doe.gov/bestpractices/software\\_tools.shtml](http://www.oit.doe.gov/bestpractices/software_tools.shtml).

### Task 2.5:

Department of Commerce, Economic and Statistics Administration, U.S. Census Bureau, Ball and Roller Bearing Manufacturing: 2002, by Theodore W. Kassinger, Kathleen B. Cooper, Charles Louis Kincannon. [Washington, D.C.]: U.S. Department of Commerce, Economic and Statistics Administration, January 2005, 6.

Department of Commerce, Economic and Statistics Administration, U.S. Census Bureau, Motor Vehicle Transmission and Power Train Parts Manufacturing: 2002, by Theodore W. Kassinger, Kathleen B. Cooper, Charles Louis Kincannon. [Washington, D.C.]: U.S. Department of Commerce, Economic and Statistics Administration, January 2005, 6.

Department of Commerce, Economic and Statistics Administration, U.S. Census Bureau, Mechanical Power Transmission Equipment Manufacturing: 2002, by Theodore W. Kassinger, Kathleen B. Cooper, Charles Louis Kincannon. [Washington, D.C.]: U.S. Department of Commerce, Economic and Statistics Administration, January 2005, 6.

Department of Commerce, Economic and Statistics Administration, U.S. Census Bureau, Speed Changer, Industrial High-Speed Drive and Gear Manufacturing: 2002, by Theodore W. Kassinger, Kathleen B. Cooper, Charles Louis Kincannon. [Washington, D.C.]: U.S. Department of Commerce, Economic and Statistics Administration, January 2005, 6.



**Task 5.1:**

Steve Dickerson, CAMotion, Inc.; Ai-Ping Hu, CAMotion; Inc, Joe Pack, Timken Co. “A Large, High-Speed, Machine-Tending Robot”, Cleveland Exposition and Conference Emphasis on Flexible Manufacturing, Cleveland OH, June 7 – 9, 2005

See video at <http://www.camotion.com> homepage

Lightweight, Low-Precision Machines for a Competitive Advantage, SME Technical Paper TP04PUB168, Automation and Assembly Conference, May 2004.

Rhim, S., Hu, A, Sadegh, N, Book, W.J., “Combining a Multirate Repetitive Learning Controller with Command Shaping for Improved Flexible Manipulator Control,” ASME. Journal of Dynamic Systems, Measurement, and Control, June 2001.

Dickerson, S.L., Book, W.J., Sadegh, N., “Precision Apparatus with Non-rigid Imprecise Structure and Method for Operating Same,” U.S. Patent number 5,946,449.

**Task 5.2:**

Energy Industries of Ohio “Robotics in Manufacturing Technology Roadmap”, report from June 29, 2006 robotics in manufacturing workshop available online from the U.S. Department of Energy’s Energy Efficiency and Renewable Energy website

[http://www.eere.energy.gov/industry/sensors\\_automation/news\\_detail.html/news\\_id=10633](http://www.eere.energy.gov/industry/sensors_automation/news_detail.html/news_id=10633)