

## STATUS OF THE SPARC-X PROJECT\*

C. Vaccarezza, D. Alesini, M. Bellaveglia, S. Bertolucci, R. Boni, M. Boscolo, M. Castellano, A. Clozza, L. Cultrera, G. Di Pirro, A. Drago, A. Esposito, M. Ferrario, L. Ficcadenti, D. Filippetto, V. Fusco, A. Gallo, G. Gatti, A. Ghigo, C. Ligi, A. Marinelli, M. Migliorati, A. Mostacci, E. Pace, L. Palumbo, L. Pellegrino, M. Preger, R. Ricci, C. Sanelli, M. Serio, F. Sgamma, B. Spataro, A. Stella, F. Tazzioli, M. Vescovi, C. Vicario, INFN-LNF, Frascati, RM, Italy  
 F. Ciocci, G. Dattoli, A. Dipace, A. Doria, F. Flora, G.P. Gallerano, L. Giannessi, E. Giovenale, G. Messina, P.L. Ottaviani, S. Pagnutti, G. Parisi, L. Picardi, M. Quattromini, A. Renieri, G. Ronci, C. Ronsivalle, M. Rosetti, E. Sabia, M. Sassi, A. Torre, A. Zucchini, ENEA C.R. Frascati, RM, Italy  
 M. Mattioli, D. Pelliccia, Università di Roma I La Sapienza, Roma, Italy  
 L. Catani, E. Chiadroni, A. Cianchi, E. Gabrielli, C. Schaerf, INFN-Roma II, RM, Italy  
 P. Musumeci, M. Petrarca, INFN-Roma, Roma, Italy  
 F. Alessandria, A. Bacci, R. Bonifacio, I. Boscolo, F. Broggi, C. De Martinis, F. Castelli, S. Cialdi, D. Giove, A. Flacco, C. Maroli, V. Petrillo, A.R. Rossi, L. Serafini, INFN-Milano, Milano, Italy  
 A. Perrone, INFN-Lecce, Lecce, Italy  
 M. Labat, O. Tcherbakoff, G. Lambert, D. Garzella, M. Bougeard, P. Breger, P. Monchicourt, H. Merdji, P. Salières, B. Carré, Service des Photons Atomes et Molécules, CEA Saclay, DSM/DRECAM, France  
 M. E. Couprie, SOLEIL, Sant-Aubin, Gif-sur-Yvette CEDEX, France  
 P. Emma, SLAC, Menlo Park, CA, USA  
 C. Pellegrini, S. Reiche, J. Rosenzweig, UCLA, Los Angeles, CA, USA

### Abstract

SPARC-X is a two branch project consisting in the SPARC test facility dedicated to the development and test of critical subsystems such as high brightness photoinjector and a modular expandable undulator for SASE-FEL experiments at 500 nm with seeding, and the SPARC facility aiming at generation of high brilliance coherent radiation in the 1.5-13 nm range, based on the achieved expertise. The projects are supported by MIUR (Research Department of Italian Government) and Regione Lazio. SPARC has completed the commissioning phase of the photoinjector in November 2006. The achieved experimental results are here summarized together with the status of the second phase commissioning plans. The SPARC project is based on the generation of ultra high peak brightness electron beams at the energy of 1 and 2 GeV generating radiation in the 1.5-13 nm range. The construction is at the moment planned in two steps starting with a 1 GeV Linac. The project layout including both RF-compression and magnetic chicane techniques has been studied.

### SPARC 1<sup>ST</sup> PHASE COMMISSIONING RESULTS

The goal of the SPARC-X project is the realization of a X-ray coherent radiation source of high brilliance and tunable to the needs of the users community scientific case [1]. SPARC is meant to be a test facility for the high brightness photoinjector prototype of the SPARC project

\*Work partially supported by the EU Commission in the sixth framework program. Contract No. 011935 EUROFEL and MIUR (Research Department of Italian Government).

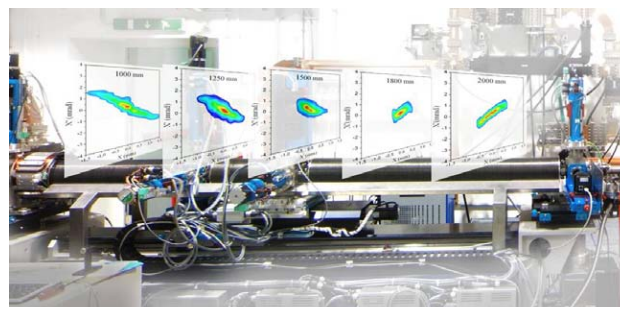

Figure 1: The SPARC emittance-meter: a movable slits plus screen system that allows the beam transverse phase space characterization along its propagation.

producing a 150-200 MeV electron beam to drive a SASE-FEL in the visible light and exploring all the most critical issues of the future X-Ray source subsystems. The relevance of the first phase commissioning results lies in the detailed study of the emittance compensation process of the gun-solenoid system and in the novelty of the employed diagnostic devices, so called emittance meter [2], that allowed the measurement of the electron beam features downstream the gun and the first experimental observation of the double emittance minimum effect as predicted by the theory [3]. The results relied on extensive manipulation of both transverse and longitudinal laser pulse profile [4], and were confirmed by a careful benchmarking of the numerical codes employed for tracking so far [5]. In Fig. 1 the emittance meter device is shown with a picture superposition of an example of transverse phase space reconstruction along

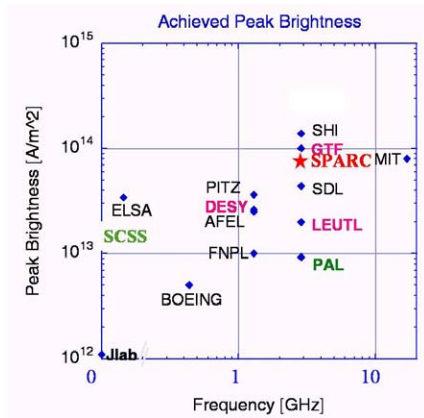

Figure 2: Achieved beam brightness.

the beam propagation. The best achieved beam brightness is about  $7 \times 10^{13}$  A/m<sup>2</sup>, with a peak current of 92 A, 0.8 nC charge, 8.9 ps FWHM (rise time < 2.6ps), and emittance 1.6  $\mu$ m as it was the SPARC project design goal [4]. In Fig. 2 the SPARC result is reported together with others worldwide.

## SPARC 2<sup>ND</sup> PHASE COMMISSIONING PLANS

The relevance of the obtained results during the SPARC commissioning first phase lies in the gained expertise on tuning the gun-solenoid-laser system in order to produce a beam with the high brightness design value, but mainly on the agreement between the experimental results and the beam emittance longitudinal evolution as predicted by the theory [6]. The reason is that the optimized photoinjector working point performance is based on the proper matching between the SPARC linac and the beam emittance oscillation downstream the gun.

### The Linac

According to the above mentioned scheme three s-band accelerating sections have been installed, after the emittance meter removal, at the exit of the gun as shown in Fig. 3, to rise the beam energy up to 150+200 MeV., with an accelerating gradient of 25 MV/m. To compensate the longitudinal phase space curvature a bi periodic X-band cavity working on  $\pi/2$  mode has been studied and realized at LNF [7]. The 17 cell cavity length



Figure 3: The SPARC linac with the s-band accelerating sections installed.

is 9 cm and it will be placed right at the exit of the RF gun. A high energy diagnostic set up is provided in the transfer line from the linac to the undulator, equipped with a 26 cm long RF-SW deflector cavity developed at LNF, to measure the bunch length with a precision of about 40  $\mu$ m [8]. Downstream the RF deflector a 15 degrees by-pass beamline is provided as a spectrometer section. The coupled system RF-deflector plus dispersive element allows the 6-D reconstruction of the beam phase space and the slice emittance measurements in both horizontal and vertical plane. The by-pass will host also a magnetic chicane for bunch compression tests. These will also be performed with the alternative velocity bunching scheme.

### The Undulator

The installation of the six 2m long undulator sections will be completed by the end of 2007. Besides the SASE radiation scheme a seeding experiment is foreseen at the SPARC facility [9]; the seed source will be obtained with higher order harmonics of a Ti:Sa laser generated in crystals and in gas. In the latter case the seed is generated in the chambers shown in Fig. 4, which has been developed and tested at CEA-Saclay within the EUROFEL programme.

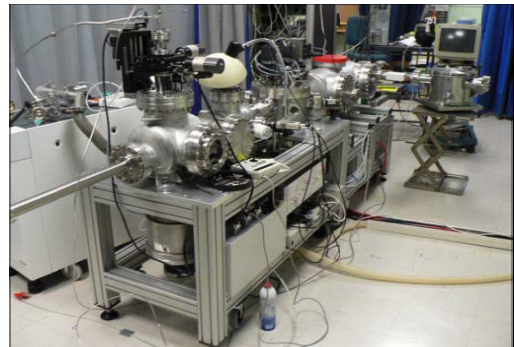

Figure 4: Harmonic Gas generation chamber

## THE SPARC PROJECT LAYOUT

The first phase of the SPARC facility has been recently approved and funded. The project is based on the generation of ultra high peak brightness electron beams at the energy of 1 and 2 GeV generating FEL radiation in the 1.5-13 nm range. The machine design is intended to be modular and planned in two steps at 1 and 2 GeV respectively. The project layout includes both RF-compression and magnetic chicane techniques.

### The Linac

The basic SPARC linac layout is based on s-band RF-TW accelerating sections, with an accelerating gradient around 25 MV/m. Downstream the SPARC-like photoinjector a first linac section rises the beam energy up to  $\approx$  300 MeV before the first magnetic chicane BC1, that brings the beam peak current from 100 A (SPARC design value) up to 300 A, followed by a second accelerating

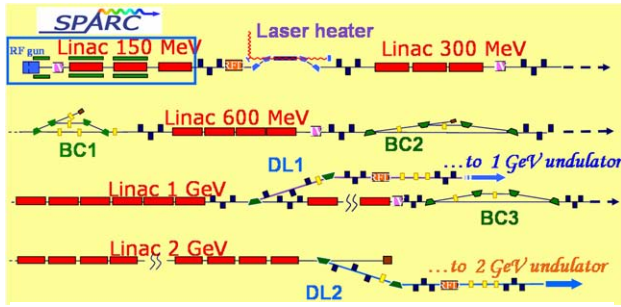

Figure 5: SPARC project schematic layout

section up to 600 MeV and the magnetic compressor BC2 to obtain a peak current  $I_{pk} \approx 1$  kA. A hybrid compression scheme with velocity bunching and BC2 only is nevertheless foreseen and RF compression tests will be performed at the SPARC facility in the second half of 2007. After the BC2 compressor the energy of the beam is raised up to 1 GeV and the first dogleg DL1 delivers the beam to the 1 GeV undulator system, where both SASE

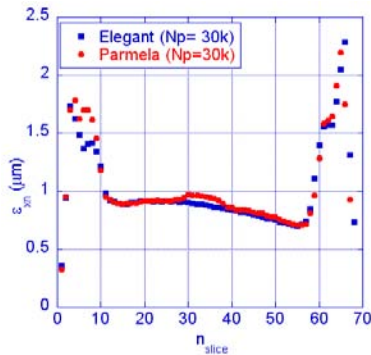

Figure 6: Slice analysis of the horizontal beam emittance after BC2 compressor as obtained with Elegant and Parmela code simulation.

and seeded radiation schemes are foreseen for a radiation length in the range of  $\lambda_r \approx 13 \div 5$  nm. After the 1 GeV DL1 dogleg insertion another linac section brings the beam energy up to 1.5 GeV where the third magnetic compressor BC3 is located, in order to reach a peak current of the order of  $I_{pk} \approx 2.5$  kA. After the last linac, at around 2 GeV, a second dogleg DL2 brings the beam to the second undulator system for radiation length in the range of  $\lambda_r \approx 1.5 \div 5$  nm. A special attention is devoted to the space charge effect relevance in both the BC2 and BC3 compressors: in Fig. 6 the simulation results for the transverse beam emittance are reported as obtained with the Elegant and Parmela codes. A projected emittance dilution of the 30% is obtained so far; the compressor optimization is still in progress in order to further reduce the transverse dilution due to the space charge effect.

### The Undulator and FEL

Both SASE and seeded radiation modes are foreseen at each of the two energy steps of the SPARC channel. As an example in Table 1 the very preliminary parameter list is reported for the two undulators of a possible seeding experiment at 2.3 GeV.

Table 1: Preliminary Parameter list of Seeding Experiment example at 2.3 GeV. (Fig. 7)

	Undulator 1	Undulator 2
Periods	21	42
Sections	9	10
Period (cm)	5.4	2.7
K	4.299	2.51

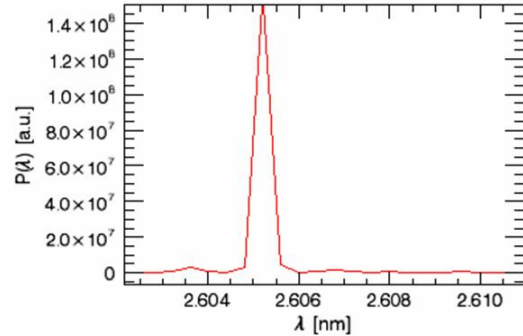

Figure 7: Radiation Spectrum of the fifth harmonic for a possible seeded scheme at 2.3 GeV.

In Fig. 7 the radiation spectrum is shown for the fifth harmonic of the  $\lambda=13$  nm seed. An intensive study is ongoing to explore the most suitable configurations according to the user community needs.

## PROJECT SCHEDULE

The first phase of SPARC commissioning successfully ended by Dec. 2006, the second part is meant to be completed by the end of 2007 with the SASE experiment at 530 nm, and SASE& seeding HHG test at 260-160-114 nm. For the SPARC source the project schedule foresees the facility TDR and the Building Project completed by the end of 2007, while the tunnel and building construction by the end of 2008. The installation is foreseen to be completed by the end of 2010, then after one year of Sub-system tests, the Commissioning of the machine will start in 2012.

## REFERENCES

- [1] [http://www.lnf.infn.it/conference/sparx05/Giornate di Studio SPARC e Applicazioni](http://www.lnf.infn.it/conference/sparx05/Giornate%20di%20Studio%20SPARC%20e%20Applicazioni)
- [2] A. Cianchi, *et al.*, Proc. of DIPAC07, Venice, Italy
- [3] M. Ferrario, *et al.*, "Experimental results with the SPARC emittance-meter", these Proceedings
- [4] C. Vicario, *et al.*, "Laser and RF Synchronization Measurements at SPARC", these Proceedings
- [5] C. Ronsiville *et al.* "Comparison Between SPARC E-Meter Meas. and Simulations", these Proceedings
- [6] [http://www.lnf.infn.it/acceleratori/sparc/SPARC Technical Design Report](http://www.lnf.infn.it/acceleratori/sparc/SPARC%20Technical%20Design%20Report)
- [7] B. Spataro, *et al.*, "A Bi-periodic X-band RF cavity for SPARC", Proc. of EPAC06, Edinburgh, Scotland
- [8] L. Ficcadenti, *et al.*, "RF measurements results of the final brazed SPARC RF deflector", these Proceedings
- [9] L. Giannessi, *et al.*, "Future Seeding Experiment at SPARC", Proc. of FEL 2006, Berlin, Germany.