

TAMPA ELECTRIC NEURAL NETWORK SOOTBLOWING

Quarterly Report:

October 1, 2002 – December 31, 2002

Prepared By:

Mark A. Rhode, P.E.
Sr. Consulting Engineer
Advanced Technologies

Submission Date:

January 2003

DOE Award Number:

DE-FC26-02NT41425

“This report was prepared as an account of work sponsored by an agency of the United States

Government. Neither the United States Government nor any agency thereof, nor any of their employees, makes any warranty, express or implied, or assumes any legal liability or responsibility for the accuracy, completeness, or usefulness of any information, apparatus, product, or process disclosed, or represents that its use would not infringe privately owned rights. Reference herein to any specific commercial product, process, or service by trade name, trademark, manufacturer, or otherwise does not necessarily constitute or imply its endorsement, recommendation, or favoring by the United States Government or any agency thereof. The views and opinions of authors expressed herein do not necessarily state or reflect those of the United States Government or any agency thereof.”

ABSTRACT:

Boiler combustion dynamics change continuously due to several factors including coal quality, boiler loading, ambient conditions, changes in slag/soot deposits and the condition of plant equipment. NO_x formation, Particulate Matter (PM) emissions, and boiler thermal performance are directly affected by the sootblowing practices on a unit.

As part of its Power Plant Improvement Initiative program, the US DOE is providing co-funding (DE-FC26-02NT41425) and NETL is the managing agency for this project at Tampa Electric's Big Bend Station. This program serves to co-fund projects that have the potential to increase thermal efficiency and reduce emissions from coal-fired utility boilers. A review of the Big Bend units helped identify intelligent sootblowing as a suitable application to achieve the desired objectives. The existing sootblower control philosophy uses sequential schemes, whose frequency is either dictated by the control room operator or is timed based.

The intent of this project is to implement a neural network based intelligent sootblowing system, in conjunction with state-of-the-art controls and instrumentation, to optimize the operation of a utility boiler and systematically control boiler fouling. Utilizing unique, on-line, adaptive technology, operation of the sootblowers can be dynamically controlled based on real-time events and conditions within the boiler. This could be an extremely cost-effective technology, which has the ability to be readily and easily adapted to virtually any pulverized coal fired boiler.

Through unique on-line adaptive technology, Neural Network-based systems optimize the boiler operation by accommodating equipment performance changes due to wear and maintenance activities, adjusting to fluctuations in fuel quality, and improving operating flexibility. The system dynamically adjusts combustion setpoints and bias settings in closed-loop supervisory control to simultaneously reduce NO_x emissions and improve heat rate around the clock.

TABLE OF CONTENTS

Introduction

Executive Summary

Experimental

Results and Discussion

Conclusion

INTRODUCTION:

One of the effects of burning coal in utility boilers is the buildup of soot and slag on the heat transfer surfaces within the boiler. Soot and slag buildup causes a redistribution/reduction of the heat transferred across various sections of the furnace, resulting in a

redistribution/reduction of heat absorption. This condition often leads to a heat rate penalty and increased NO_x emissions. Adverse heat rate impacts arise from numerous factors inclusive of, but not necessarily limited to; incomplete combustion, unbalanced steam generation, excessive use of desuperheater sprays and high exit gas temperatures. Thermal NO_x generation has been well documented as largely a function of temperatures within and around the combustion zone. As the boiler section of the furnace becomes excessively slagged, the heat transfer ability is impaired which results in higher temperatures within that region. This results in higher levels of NO_x.

Fouling of the boiler leads to poor efficiencies due to the fact that heat which could normally be transferred to the working fluid remains in the flue gas stream and exits to the environment without beneficial use. This loss in efficiency translates to higher consumption of fuel for equivalent levels of electric generation, hence more gaseous emissions are also produced. Another less obvious problem exists with fouling of various sections of the boiler relating to the intensity of peak temperatures within and around the combustion zone. Total NO_x generation is primarily a function of both fuel and thermal NO_x production. Fuel NO_x, which generally comprises 20%-40% of the total NO_x generated, is predominately influenced by the levels of oxygen. Thermal NO_x, which comprises approximately 20% - 50%¹ of the total NO_x, is a function of temperature. As the fouling of the boiler increases and the rate of heat transfer decreases, peak temperature increases and so does the thermal NO_x production.

Due to the composition of coal, particulate matter is also a by-product of coal combustion. Modern day utility boilers are usually fitted with electrostatic precipitators (ESP) to aid in the collection of particulate matter. Although extremely efficient, these devices are sensitive to rapid changes in inlet mass concentration as well as total mass loading. Without extreme care and due diligence, excursions or excessive soot can overload an ESP, resulting in high levels of PM being released.

Traditionally, utility boilers are equipped with sootblowers, which are lances that use, steam, water or air to dislodge and clean the surfaces within the boiler. The number of lances on a given unit ranges from several to over a hundred. Traditional sootblowing schemes involve fixed schedules for activating the blowers or the experience of the operators who manually activate various fixed sequences. Time based sequencing of sootblowers has been a traditional method employed by power plants, both domestically and abroad, to improve cleanliness within boilers. These systems are generally automated and are initiated by a master control device. In some cases, operators activate the systems manually on the basis of established protocols or generic procedures. These methods result in indiscriminate cleaning of the entire boiler or sections thereof, regardless of whether portions are already clean. Hence, traditional methods of sootblowing may be effective in assuring that a boiler is clean, but they fail to optimize the heat transfer rates therein, so as to maximize its operation relative to emissions and unit performance. In all cases, operators are challenged with a number of non-linear and conflicting objectives while ensuring that the boiler is stable and capable of meeting system dispatch requirements.

¹ EPRI – TR-102906 Retrofit NO_x Controls for Coal-Fired Utility Boilers

Simultaneously optimizing the objectives of NO_x, PM and heat rate is difficult and unrealistic for a control room operator, even more so when that operator is also required to maintain control of the balance of the unit(s) equipment. The industry has recently been introduced to a number of “Intelligent” Rule-Based systems that derive their knowledge base from operator experiences, static plant design data, and general thermal principles. Whereas these systems are better than the traditional methods, they also fail to fully respond to the dynamic operation and condition of boilers. Rule-based systems are not readily adaptable to transitional operation of present day boilers, which, as a result of deregulation, are subject to volatile changes in operation and fuel types or blends. Furthermore, time or rule based systems are not the answer due to the complexity of the individual components, combinations thereof and the desire to satisfy multiple objectives in a dynamic real-time environment. Additionally, rule-based systems are only as good as the rules that drive them and established rules cannot accommodate the diverse set of operating conditions that may be encountered on a daily basis.

Neural networks have established themselves in a variety of industries to satisfy multiple goals or objectives in highly complex systems. These intelligent software systems have the ability to learn extremely complex relationships and trends between a great many input variables and then determine what control parameter changes are necessary to achieve the predetermined goals. Artificial Intelligence based systems are not designed to replace operators, but rather are an enabling tool. Recommended settings derived by neural networks and optimization systems can either be presented in the “advisory” form to the operator or can be integrated into the control logic on a closed-loop basis.

Intelligent Sootblowing

The goal of the project will be to develop a Neural Network driven Intelligent Sootblowing (NN-ISB) system module that proactively modifies the sequence of sootblowing in response to real-time events or conditions within the boiler, in lieu of time or general rule-based protocols. To date, the ability to intelligently blow soot while satisfying multiple and specific user defined objectives has not been integrated with an on-line, automatic and adaptive neural network driven sootblowing system. The NN-ISB module will provide an asynchronous, event-driven technology that is adaptable to changing boiler conditions.

Some of the basic technology components proposed for the project are commercially proven. However, the project also incorporates the use and application of several new or newly applied components and/or systems in conjunction with the NN-ISB system. The objective will be to reduce emissions and provide improvements in efficiency and reliability by employing synergistic approaches, which have not been possible with prior technologies. Some of the salient technologies planned for implementation during this project include, state-of-the-art heat flux and slag sensors, dual plane acoustic pyrometers, integration of boiler cleanliness and performance models with a neural network, and directional water cannons.

Technology advancements in the past few years have resulted in the introduction of several diverse systems that could change the basic process of sootblowing. Specifically, robust temperature measurement products have emerged that allow localized measurement of

fireside temperatures and heat transfer rates in both the furnace zone as well as the convection and backpass regions. The combination of these advanced measurement techniques coupled with today's high speed numerical processing allows for real time determination of tube fouling and levels of boiler tube cleanliness. Albeit limited in nature and scope, utilization of some of these technologies have seen some successes in their ability to improve the efficiency of the sootblowing process for US utility boilers.

Although prior testing and limited demonstrations have yielded some benefits in regard to NO_x, PM and heat rate, these efforts have not been fully exploited in the development of a system that has the ability to understand, evaluate and optimize the process with multiple real-time objectives. The advantages of the knowledge capture and adaptive, counter-intuitive interactions with the NN-ISB system provides, the opportunity for a modular sootblowing optimization subsystem capable of significant operational benefits. Furthermore, since all utility boilers that fire pulverized coal and oils generate varying levels of soot and slag, the commercialization and benefits of this innovative technology has the potential to be readily and easily applied to a large population of power plants.

Independent manual sequencing of specific sootblowers has shown benefits in the area of heat rate efficiency improvement, NO_x reduction and other areas relevant to efficiency and reliability. It is expected that additional, hard to quantify, gains will be realized in the areas of: tube erosion (minimized), auxiliary power consumption (minimized), perturbations in extraction steam flow (made more level), and particulate generation (managed to minimize impact on ESP). Of particular note, traditional sootblowers are high cost O&M devices. Steam consumption rates of 30,000#/hr are not uncommon and create substantial heat rate penalties. The maintenance costs are also very high considering the high pressures and temperatures, well in excess of 1000 degrees F, that exist in many cases.

The NN-ISB system proposed herein will utilize the Neural Network technology from Pegasus Technologies, which has been implemented successfully for combustion optimization applications. This project shall use Neural Network based optimization, and state-of-the-art sensing and sootblowing equipment to direct the operation of the sootblowing systems in such a manner as to reduce NO_x & PM emissions, while concurrently improving the heat rate. Neural networks have not yet been fully implemented for ISB applications within the utility industry. Through these development activities, a NN-ISB will react to and take into account the heat distribution within the boiler, equipment life, emissions, and the overall cost of generating power. The objective is to develop a system to automatically determine the need for sootblowing in specific sections of a boiler and activate a blower or set of blowers for removing soot using adaptive, advanced control techniques. The net impact to the industry will be the demonstration of a commercially viable system that improves overall plant reliability and operations by reducing production cost, while also minimizing emissions.

EXECUTIVE SUMMARY:

This project became effective after successful negotiation of the Cooperative Agreement related to the DOE award number DE-FC26-02NT41425, whose effective date was July 19, 2002. During this reporting phase, the equipment listed was installed on Big Bend Unit #2. Salient installation notes are listed after each piece of equipment, which in certain instances may be unique to the Big Bend facility. No system startup was performed during this period since the unit was returned to service in the latter half of December after an extended outage, whereby all emphasis was placed on safe and reliable operation of the unit.

General Physics EtaPro 8 – A heat rate performance monitoring system, which serves two primary functions. The first requirement involves taking baseline data of the unit to document “as-found” heat rates at various loads. These will be compared against post neural network sootblowing optimization during the demonstration phase to measure and report heat rate improvements attributable to the system, which have been predicted to be approximately 2%. The second function of the EtaPro system is to provide real time boiler cleanliness information to the neural network system, which will be analyzed and processed for control of the sootblowers.

This system was installed at the beginning of this phase of reporting, or just prior to Big Bend Unit #2 being taken out of service for the outage. No significant problems were encountered during the installation of this system, which resides in the existing DCS system. The station historian, PI, was expanded to accommodate additional data points.

SBC 1000 Sootblower Control System – The SBC 1000 provides a bi-directional link between the actual sequencing panel and the plant DCS. This allows for information related to sootblower execution to be data logged and transmitted for neural network control, transmitted to the other devices (i.e., FORREY ESP control system) for interactive optimization, and received from the NN-ISB.

The SBC 1000 was a simple installation, which involved a PLC rack and PC whereby the core programming resides in the PLC. The terminations for the existing sootblowers were merely connected to the new I/O cards, and new sootblowers and the watercannon system communications were also landed on I/O cards. Program changes are made on the PC, and then uploaded to the PLC for execution. The SBC 1000 system also incorporates steam flow, pressure and motor amps as diagnostic tools to access real-time operation of the sootblowers. This is accomplished by making a signature of each sootblower and comparing subsequent operating characteristics against the baseline. Due to the limited space within the control room, a common display screen and keyboard is shared between this system and the watercannon programming/operating screen. Most of the sootblowers were characterized during this reporting phase however several outstanding sootblowers require setup during the next quarter.

Slag Sensors – Eight slag sensors utilizing electrical conductivity as the method for determination of slag accumulation will be installed in conjunction with heat flux sensors. Two of the sensors will be installed in close proximity to the heat flux sensors to derive comparative data while the balance will be installed in between the heat flux sensors to gather additional condition assessment data.

Although the intent of this project is to install eight sensors, only two were installed during this outage. The two installed were adjacent to heat flux sensors so as to determine if a correlation exists between the sensors. Once and if established, then the other six sensors will be installed. The conduit, junction boxes, and control cabinets have been installed for these, however before making additional penetrations into the boiler it was deemed prudent to

evaluate two first. It is anticipated that the remaining six can easily be installed during a weekend outage and would be done within 2-3 months of data acquisition from the two installed. There is no adverse impact to the project in delaying the installation of the six sensors.

AccuTemp Acoustical Pyrometer Grids – Two grid network are being installed, one at the furnace outlet plane and the other at the economizer outlet plane. The information derived from this system shall be used in conjunction with the stations existing thermal couple data on various high temperature circuits and the boiler cleanliness module to more accurately determine the slag conditions in the convective portion of the furnace.

These systems were normally designed for balanced draft units, whereas Big Bend unit #2 is a pressurized unit. Therefore, some minor field design changes were required to accommodate positive pressure sealing and purging. The sound generator required additional mounting requirements to allow for thermal growth of the boiler, but was easily modified by elongation of the mounting holes. The system was tested and calibrated prior to the unit being returned to service. The sound generators develop energy levels of approximately 180dB, therefore safety precautions must be used to avoid personnel injury for those that may perform work within the boiler. It should be noted that work was concurrently being performed downstream of the APH, and the sound levels were attenuated to well less than 80dB at those locations. The unit is also equipped with an acoustical leak detection system, however no adverse impacts were realized due to the short duration of sound generation from the AccuTemp system. At the conclusion of this reporting period, temperature profiling was available from the control cabinets, however communication cable needed to be terminated to the SBC 1000 PC which contains the programming for display within the control room. The SBC 1000 is also the communications link to the NN system.

Four Water Cannons & Sootblowers – Four (4) water cannons are being installed complete with Clyde-Bergermans Smart Sensor™ control system, which includes sixteen (16) heat flux sensors. These water cannons shall have the capability of accurately cleaning the waterwalls to achieve various levels of cleanliness as determined by the neural network system. Prior to implementation of the neural network system, the system shall be operated using standard operating procedures. The current work also includes the addition of several conventional sootblowers in the convective region to allow for strategic cleaning.

The system required additional work since the drawings provided by Clyde-Bergerman did not contain all necessary information and detail. Platforms were also required to facilitate access to all the field devices. Many of the parts supplied were loose, and instructions were not provided for assembly. Despite these problems the system was installed and initial testing prior to startup of the unit proved successful. Three of four watercannons were calibrated, however one of the cannons had a faulty x-axis drive assembly and was replaced by C/B as a warranty item. A communication cable is required to be installed linking it the SBC 1000 system. Another minor problem involved the recirculation line from the Sundyne pump skid. Since the skid requires positive pressure, the system continuously had discharge from the skid via the recirculation line. This flow was estimated to be 20-40 gpm, which not only wasted service water but also caused the forced fan basin to overflow. The correction to this

problem involved the installation of a new solenoid operated valve, rerouting of a line, and a program change.

Pegasus Neural Network - The contract between Tampa Electric and Pegasus was completed during this phase, which included review and comment from DOE before execution of that contract. Pegasus started procurement of the SunWorkstation, preliminary engineering, and conducted engineering meetings with Solvera at its facility during this phase.

The first project kick-off meeting was held on August 27, 2002 including various Tampa Electric personnel, Pegasus Technologies, Clyde-Bergerman, General Physics, and Solvera. The focus of this meeting was to ensure that all the requisite components of the project had been identified and to establish a network for communication of data. The project participants concluded that the flow of information amongst the various existing systems and new systems for this project should take the form shown in the illustration below.

Proposed Communications Network

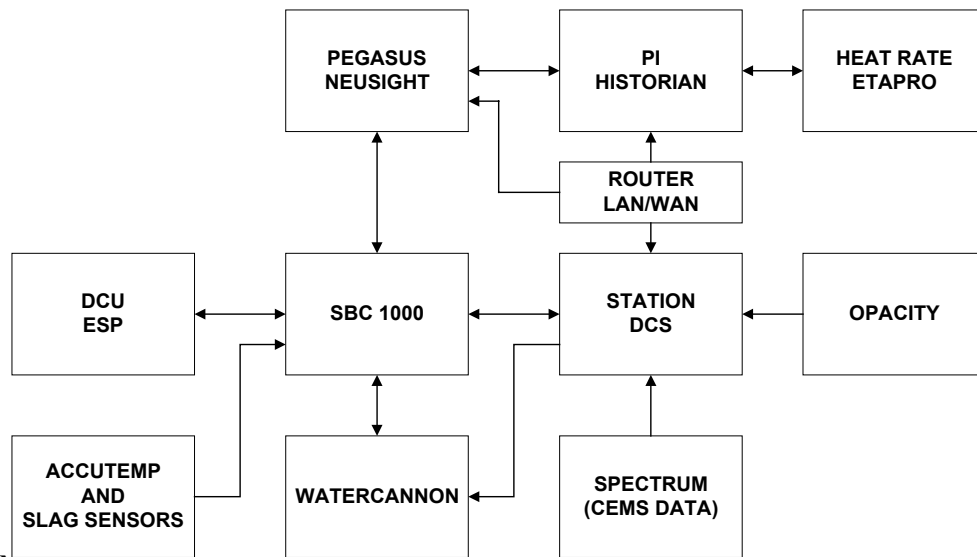

EXPERIMENTAL:

Since the unit was returned to service at the end of this reporting phase there are no experimental aspects of the project ready to be discussed. However, after start-up of the unit comparative data between the slag sensors and the heat flux sensors shall be available as will preliminary baseline data.

RESULTS AND DISCUSSION:

The core physical equipment has been installed on Tampa Electric's Big Bend unit 2 which returned to service the end of December 2002. After its return to service and start-up of the new equipment reportable information shall be available. It is also anticipated that baseline

data of the unit will be available shortly thereafter.

CONCLUSION:

Albeit that the project is in its infancy the intent of this project objectives are to implement a neural network based intelligent sootblowing system in conjunction with state-of-the-art controls and instrumentation, to optimize the operation of a utility boiler, and systematically control boiler fouling. State-of-the-art heat flux and slag sensors, dual plane acoustic pyrometers, directional water cannons, and integration of boiler cleanliness and performance models with a neural network are some of the prominent components of this project. Operation of the sootblowers can be dynamically controlled based on real-time events and changing conditions within the boiler using on-line, adaptive technology. A new generation of cost-effective sensing equipment has the potential to provide sufficient measurable inputs to a NN-ISB sootblowing process to meet one or more of the objectives, which may include:

NOx Reduction through more stable control of furnace exit temperatures, and more even distribution of temperature across the furnace exit and convection zones.

Particulate Matter Reduction through reduced excess carbon, uniform ESP inlet temperatures, and coordination of sootblowing execution with ESP rapping execution.

Heat Rate Improvement through improved localized temperature consistency and better control of furnace and subsequent heat transfer zone temperatures.

This could be an extremely cost-effective technology, which has the ability to be readily and easily adapted to virtually any pulverized coal-fired boiler. The net impact to the industry will be the demonstration of a commercially viable system that improves overall plant reliability and operations by reducing production cost, while also minimizing emissions.