

LM-06K103  
January 30, 2007

---

---

## Liquid Metal Flow Meter Final Report

C Andersen, S Hoogendoorn, B Hudson, J Prince, K Teichert, J Wood, K Chase

---

---

### NOTICE

This report was prepared as an account of work sponsored by the United States Government. Neither the United States, nor the United States Department of Energy, nor any of their employees, nor any of their contractors, subcontractors, or their employees, makes any warranty, express or implied, or assumes any legal liability or responsibility for the accuracy, completeness or usefulness of any information, apparatus, product or process disclosed, or represents that its use would not infringe privately owned rights.

# Liquid Metal Flow Meter

## Final Report

April 17, 2006

Lockheed Martin-NY  
Liaison: Doug Milone

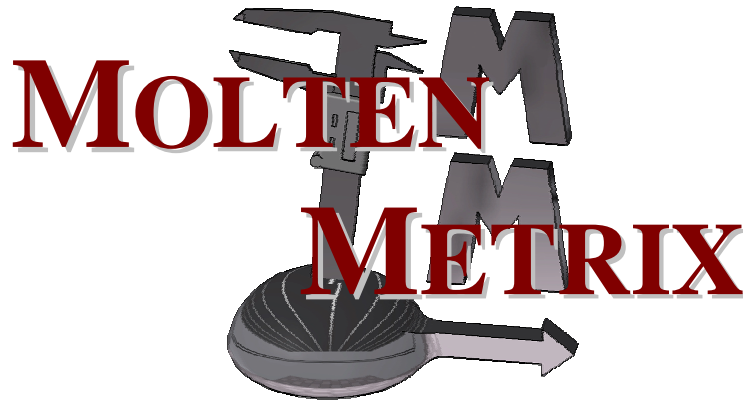

**Team #14**

Cameron Andersen · Summer Hoogendoorn · Benjamin Hudson  
Joseph Prince · Kendall Teichert · Jonathan Wood  
Dr. Ken Chase

**Capstone Program  
College of Engineering and Technology  
Brigham Young University**

Coach Approval: \_\_\_\_\_

# TABLE OF CONTENTS

<b>EXECUTIVE SUMMARY .....</b>	<b>3</b>
<b>I. INTRODUCTION .....</b>	<b>6</b>
<b>II. FLOW METER FINAL DESIGN.....</b>	<b>8</b>
MACOR CERAMIC TUBE .....	8
TUNGSTEN ELECTRICAL FEEDTHROUGHS.....	9
KOVAR JOINING SLEEVE .....	9
ELECTROMAGNET.....	10
<b>III. ELECTROMAGNETIC PUMP .....</b>	<b>12</b>
<b>IV. ANALYSIS.....</b>	<b>13</b>
ANALYTICAL FLOW METER MODEL.....	13
MODEL OF INTERFERENCE FITS.....	14
HEAT TRANSFER MODEL FOR TEST LOOP .....	15
<b>V. EXPERIMENTATION .....</b>	<b>17</b>
TESTING TO DETERMINE ELECTRODE REQUIREMENTS .....	17
CORROSION TESTING.....	18
<i>Gallium vs. Stainless Steel</i> .....	18
<i>Gallium vs. Cast Iron</i> .....	19
<i>Gallium vs. Tungsten</i> .....	20
<i>Gallium vs. Kovar and Graphite</i> .....	21
CERAMIC-TO-METAL SEALANT TEST .....	22
PRESSURE TEST .....	22
FLOW RATE TEST .....	23
<i>Objective</i> .....	23
<i>Setup</i> .....	23
800° C SURVIVABILITY TEST .....	27
<b>VI. ALTERNATE LIQUID METAL CONSIDERATIONS .....</b>	<b>29</b>
<b>VII. CONCLUSIONS .....</b>	<b>30</b>
<b>VIII. APPENDICES</b>	
APPENDIX A: BIBLIOGRAPHY .....	A-1
APPENDIX B: CONTACTS .....	B-5
APPENDIX C: ANALYTICAL MODELS .....	C-1
APPENDIX D: MATERIAL PROPERTIES .....	D-6
APPENDIX E: SCHEDULE .....	E-15
APPENDIX F: DRAWING PACKAGE .....	F-16
APPENDIX G: WIRING FOR ELECTROMAGNETIC PUMP .....	G-20
APPENDIX H: CERAMIC TO METAL SEAL INSTRUCTIONS .....	H-21
APPENDIX I: FUNCTIONAL SPECIFICATIONS REPORT .....	I-22
APPENDIX J: CONCEPT GENERATION AND EVALUATION .....	J-33
APPENDIX K: DESIGN PROPOSAL REPORT .....	K-49
APPENDIX L: DESIGN ANALYSIS AND EXPERIMENTATION REPORTS.....	L-62

## Executive Summary

Measuring the flow of liquid metal presents serious challenges. Current commercially-available flow meters use ultrasonic, electromagnetic, and other technologies to measure flow, but are inadequate for liquid metal flow measurement because of the high temperatures required by most liquid metals. As a result of the reactivity and high temperatures of most liquid metals, corrosion and leakage become very serious safety concerns.

The purpose of this project is to develop a flow meter for Lockheed Martin that measures the flow rate of molten metal in a conduit. In order to develop the best meter possible for this unique flow environment, key functional specifications have been determined as follows:

- Operating temperature of 300° C
- Survivability temperature of 800° C
- Accurate measurements within  $\pm 5\%$
- Non-intrusive
- Compatible with different materials including: lead, lead bismuth, molten salt, and sodium potassium
- Continuous operation life of 10 hours
- Instrument life of 100 hours

Achieving these target specifications will ensure customer satisfaction and will enhance flow measurement technology in general. In order to find a feasible design concept, a number of non-intrusive flow technologies were researched. The conductive electromagnetic flow meter proved to be the most compatible with the key functional specifications. After extensive analysis and prototype testing, a preliminary design was selected consisting of an electrically non-conductive pipe with electrical taps, operating in a strong magnetic field as shown in Figure 1.

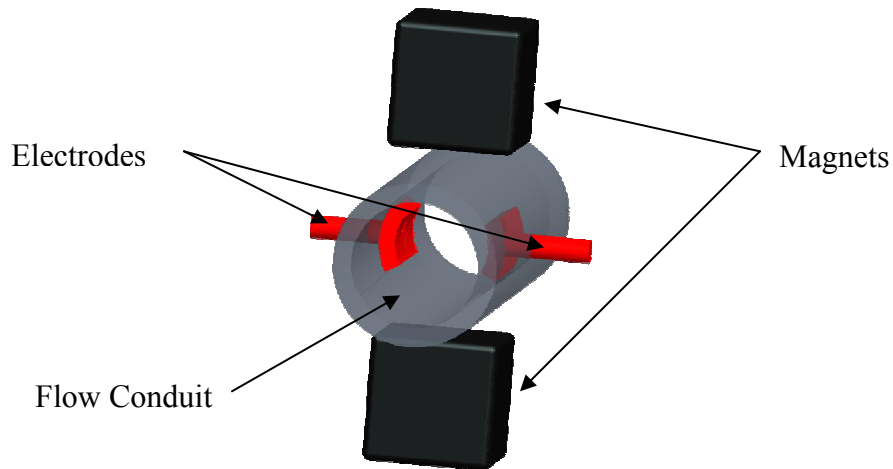

**Figure 1. Preliminary Design**

Analysis and experimentation models were developed to determine key parameters of the design in Figure 1. The most significant consisted of:

- Experimentation to determine necessary electrode size
- Analysis to design an electromagnet to impose a sufficient magnetic field
- Design of a ceramic-to-metal seal by the modeling interference fits to interface between the flow meter and circuit
- Material science research to find feasible materials for meter

Upon completion of these tests and analyses, the design shown in Figure 2 was selected.



**Figure 2. Final Design**

The design consists of a Macor ceramic section with tungsten electrical inserts. The Macor is bonded with Ceramabond to a Kovar sleeve that is welded to a threaded stainless steel pipe. After acceptance testing, it was determined that the flow meter's actual performance was characterized by the following:

- Operating temperature of 293° C
- Survivability temperature of 800° C
- Accurate measurements within  $\pm 13\%$   
(short-term accuracy within 2%)

- Non-intrusive
- Continuous operation life of 10 hours
- Instrument life of 100 hours

A high temperature liquid metal flow meter and its electromagnet were designed, constructed, tested, and calibrated. The tests conducted gave increased understanding of critical characteristics of electromagnetic flow meters. Though not every specification was exactly met, further design refinements should allow the flow meter to meet every specification.

## I. Introduction

Measuring the flow of liquid metal presents serious challenges. Current commercially-available flow meters use ultrasonic, electromagnetic, and other technologies to measure flow, but are inadequate for liquid metal flow measurement because of the high temperature requirements of most liquid metals. Corrosion and leakage also become very serious safety concerns at elevated temperatures.

Last year (2004-2005), a capstone team worked on designing a liquid metal electromagnetic pump and a flow loop as shown in Figure 3.

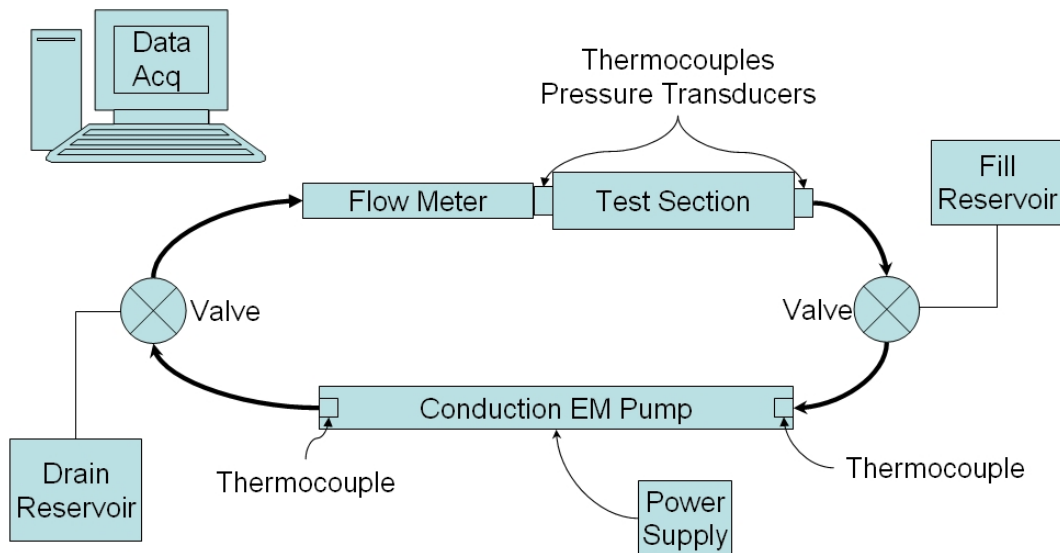

**Figure 3. Original Flow System Design**

One of the objectives was to design a non-intrusive flow system with no moving parts. The previous project was not completed entirely. Although completing this project was not the main focus of this year's project, completion of the electromagnetic pump was desirable. The work done to complete the pump will be briefly mentioned in this report, even though the pump was never used in this year's project.

The purpose of this project is to develop a flow meter for Lockheed Martin that measures the flow rate of molten metal in a conduit. Figure 4 shows a schematic of the system that was designed and used by this year's team.

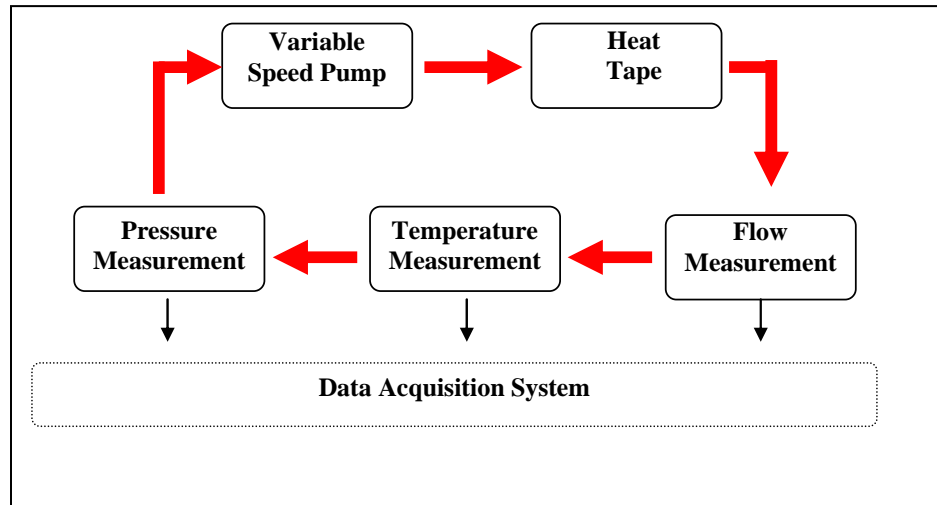

**Figure 4. Current System Diagram**

In order to develop the best meter possible for the unique flow environment, key functional specifications have been determined as follows:

- Operating temperature of 300° C
- Survivability temperature of 800° C
- Accurate measurements within  $\pm 5\%$
- Non-intrusive
- Compatible with different materials including: lead, lead bismuth, molten salt, and sodium potassium
- Continuous operation life of 10 hours
- Instrument life of 100 hours

Achieving these target specifications will ensure customer satisfaction and will enhance flow measurement technology in general. In order to achieve these specifications, a systematic product design approach was followed in the development of the final solution. This approach consisted of the following stages:

- Customer needs identification
- Target specifications selection
- Concept generation
- Concept scoring and selection
- Analytical and experimental justification
- Final acceptance testing and specifications refinement

Detailed reports of the first four steps of the design process are included in the Appendices I through L. The bibliography and contact information are contained in Appendices A and B. The analytical models, material properties database, final drawing package, and user's manuals are contained in Appendices C, D, F, and H and I, respectively. This report will focus primarily on the final design as well as the related analytical and experimental results.



## II. Flow Meter Final Design



**Figure 5. Final Design**

The final design for the flow meter incorporates magnetohydrodynamic (MHD) technology based on Lorenz's Law. The governing principles and functionality of the flow meter will be discussed fully in the Analytical Model section of this report. Figure 5 shows the finished flow meter.

The final design of the flow meter consists of the following components:

- Macor ceramic tube
- Tungsten electrical feedthroughs
- Kovar joining sleeve
- Electromagnet

Detailed engineering drawings of the components are contained in Appendix F.

### **Macor Ceramic Tube**

Because of the unique thermal and electrical environment of the flow meter, ceramics are the clear choice of material for the main body of the flow meter. Several different ceramics were considered based on their respective availability, cost, rates of thermal expansion, inertness, and formability. After a thorough comparison of the available options, a specialty ceramic called Macor was selected. Figure 6 shows the Macor used in the flow meter.

Macor has the following desirable properties:

- High electrical resistivity ( $10^{14} \Omega\text{-cm}$ )
- High temperature compatibility (1800°C melting point)

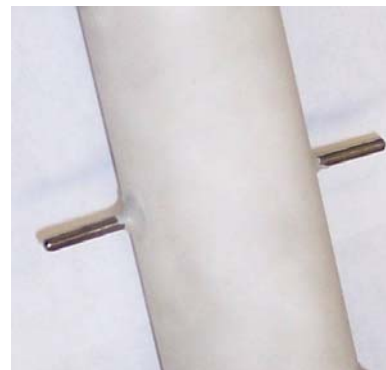

**Figure 6. Macor Ceramic Tube**

- Corrosion resistance
- Machinability

High electrical resistivity is valuable because it keeps the flow meter from shorting out. High temperature compatibility is important to allow the flow meter to reach the 800°C specification. Corrosion resistance is critical because it will need to be operated with liquid gallium. Machinability is valuable so electrical taps can be drilled in the sides of the flow meter.

### Tungsten Electrical Feedthroughs

As shown in Figure 7, the Macor tube section has two electrodes positioned perpendicular to each other, protruding through the pipe section to collect voltage generated by the metal flow. Tungsten electrodes have the following properties:

- High electrical conductivity (5.65  $\Omega$ -cm)
- High temperature compatibility (3370°C melting point)
- Corrosion resistance



**Figure 7. Tungsten Electrical Feedthrough**

### Kovar Joining Sleeve

In order to effectively seal the flow meter joints with the stainless steel flow circuit to be used for testing, a ceramic-to-metal seal was required. Because of the disparity between the rates of thermal expansion of Macor and stainless steel, and because of the weakness of ceramics in tension, an intermediate sleeve was designed to protect the Macor from any tensile stress. This sleeve, constructed from a low thermal expansion specialty alloy called Kovar, was designed to bear the tensile stress required to keep the Macor in compression (see Figure 8). A more complete analytical model of the stress fit is presented in the Model of Interference Fits portion of the Analysis section.

Kovar has the following desirable properties:

- Low thermal expansion (6.15  $\mu\text{m}/\text{m}\cdot^\circ\text{C}$ )
- High temperature compatibility (1450°C melting point)
- Corrosion resistance



**Figure 8. Kovar Joining Sleeve**

## Electromagnet

A magnetic liquid metal flow meter requires a magnetic field to produce the signal. The following options were considered to create the magnetic field:

- Modifying electromagnet designed by the previous capstone team (2004-2005)
- Generating a static field using NeBFe permanent magnets
- Designing an electromagnet capable of running on AC, DC or pulsed DC signals

Initially the electromagnet designed by the previous capstone team was considered. This produced several complications. The magnet would have had to be altered in order to accommodate the size of the flow meter. Also, the magnet could not have been used later as part of the electromagnetic pump designed by last year's team.

Using permanent magnets was an attractive choice, since they would not require an additional power supply. The main limitation with permanent magnets is their Curie temperature. Near the Curie temperature, the magnetic field produced by the magnets is reduced. Above the Curie temperature, the magnetic charge on the magnets would be permanently erased. The Curie temperature for NeBFe magnets is 320° C. Since the function specifications required continuous operation up to 300° C and survivability at up to 800° C, permanent magnets would lose their magnetic strength over time.

It was finally decided to design an electromagnet. Using the analytical models created by last year's capstone team, a magnet with two coils—each with 800 feet of 14 gauge magnet wire—was designed. These two cores were on opposite sides of the magnet's air gap and connected by an iron core as shown in Figure 9.



**Figure 9. Flow Meter Electromagnet**

This magnet required an input of 24 volts and a current of 5 amps. Unfortunately, a system that could successfully provide an AC or pulsed DC signal could not be found in time for the flow meter testing. The magnet was operated using direct current for the 10 and 100 hour flow meter tests.

Although the magnet provided a sufficient magnetic field, it was significantly lower than the calculated 0.5 T. Part of this error was due to electrical shorting of the coils onto the iron core. This short occurred from a break in the insulation that occurred as the coils were wound. Because of this short, the strength of the magnet, and thus the flow meter's output signal, was effectively cut in half. Using a gauss meter, the magnetic strength was measured to be 0.03 T, which was still considerably smaller than the analytical model predicted for this setup. A major design problem to which the discrepancy was attributed was the soft iron flanges on the wire spools. This is believed to have significantly increased the cross section of the magnet gap, resulting in a decrease in magnetic field strength. Further research should be done to verify this using nonmagnetic flanges.

### III. Electromagnetic Pump

In consideration of different sources for the flow to calibrate the flow meter, the electromagnetic pump designed by last year's team was a candidate. In order to complete the electromagnetic pump to prepare it to accelerate the metal through the flow meter, the following tasks and modifications were completed by this year's team (see Figures 10 and 11):

- Extension of the core of the magnet so that all of the necessary windings would fit.
- Machining of busbars so that the electromagnet could be connected to the stainless steel section through which the metal flows.
- Winding of wire around the core to complete the electromagnet.
- Addition of fittings to the wire so that it could be connected to the busbars and the transformer.

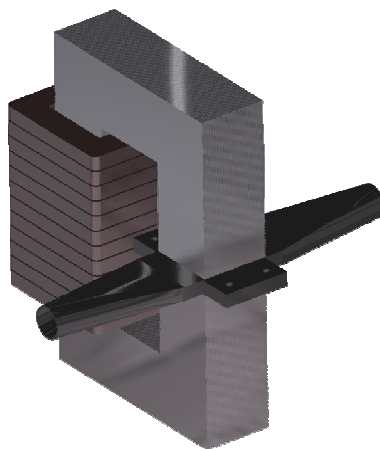

**Figure 10. CAD Rendering of Electromagnetic Pump Before Modifications**



**Figure 11. Photograph of Electromagnet after Modifications**

The electromagnetic pump was never used in the flow loop because a positive displacement pump was used in its place.

## IV. Analysis

### Analytical Flow Meter Model

In order to estimate what voltage will be read by the flow meter at different velocities, an equation was used that was derived from an application of Faraday's Law called Motional EMF (also referred to as Lorenz's Law). The governing equation of Motional EMF is given in vector Equation 1.

$$\vec{\varepsilon} = l\vec{B} \times \vec{v} \quad (1)$$

$\varepsilon$  = signal voltage generated

$B$  = magnetic field strength

$l$  = distance between electrodes

$v$  = velocity of the conductor (fluid)

In this specific application, because the magnetic field and the fluid flow are orthogonal to one another, this vector equation simplifies to scalar Equation 2.

$$\varepsilon = lBvk \quad (2)$$

$k$  = constant determined by calibration

Equation 2 serves as an initial estimate of the analytical model of the flow meter. For the specified maximum velocity and predicted magnetic field, a signal voltage of 2.3 mV was predicted.

**Table 1. Analytical Flow Meter Model Values**

Variable	Value	Justification
$K$	1	Assumed
$L$	1 in	Measured
$B$	0.03 T	Measured
$V$	3 m/s	Required
$E$	<b>2.3 mV</b>	Calculated

In the Table 1, the results assumed a  $k$  value of 1.0. After the ceramic flow meter was built and tested, a more accurate  $k$  value was determined experimentally. In proof of concept testing a value 3.2 mV was obtained, at low velocities. However, those tests were conducted using a different geometry, and could not be used to predict the constant for the final flow meter.

## Fluid Model of Flow Losses

In order to calibrate the flow meter and drive the flow, a positive displacement pump was selected. In determining what size of pump to purchase for the flow loop, it was important to know how much power would have to be delivered to overcome losses at the maximum flow rate of 31 gallons per minute (117 liters per minute). The mechanical energy equation was used to determine how much pump head would be required to maintain the flow velocity at 3 m/s (9.8 ft/s).

The required pump head was found to be 37 psi (255 kPa). This pressure was then multiplied by the area and the velocity of the flow to determine how much power would be required by the pump. The power requirements for the pump were determined to be 1 Hp (746 W) (see Appendix C for complete model).

## Model of Interference Fits

In order to answer the question of what type of materials should be used in interfacing between the ceramic pipe and the stainless steel pipe, it was very important to derive a model that could predict the stresses that would be induced through thermal expansion.

The model was created by analyzing interference fits between two concentric cylinders (with Macor on the inside and Kovar on the outside) that begin with no interference at room temperature. Figure 12 shows a graph of the maximum stresses that would be expected because of thermal expansion while raising the temperature to 800°C.

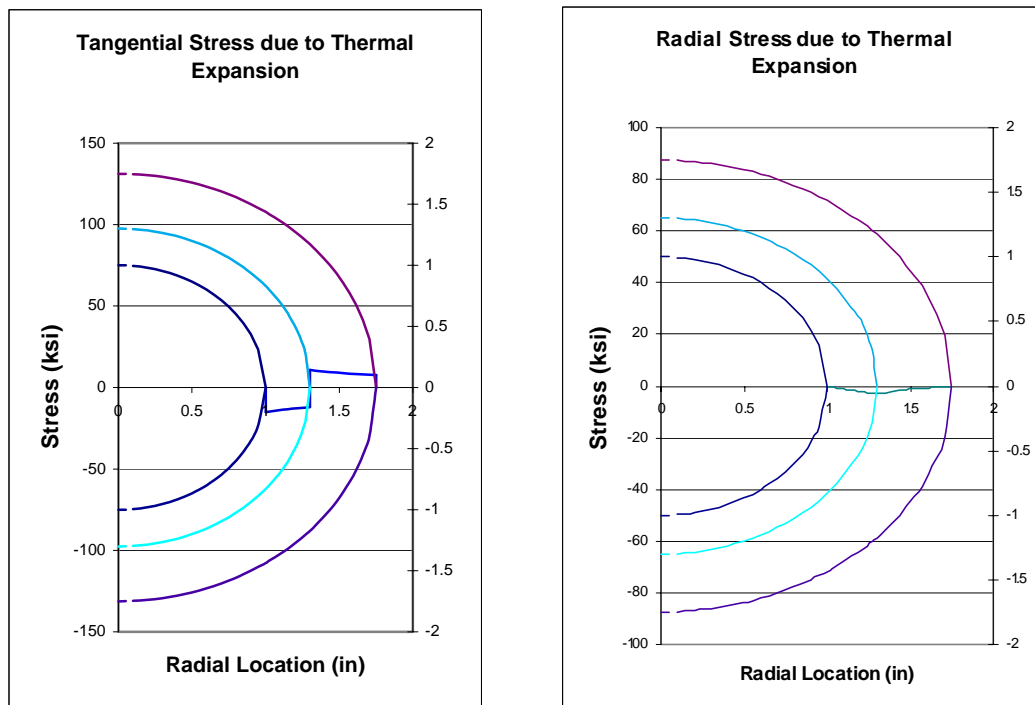

Figure 12. Radial and Tangential Stress between Macor and Kovar

It can be noted from Figure 12 that the maximum stress in the Macor due to thermal expansion from room temperature to 800°C is much less than the compressive strength of Macor, which is 50 ksi. A safety factor for the Macor was determined to be 3.3 (see Appendix C for complete model).

### Heat Transfer Model for Test Loop

In order to address the question of how to heat the flow circuit, a few ideas were surveyed ranging from modifying a barbecue to using heat tape. Because of the low-cost and quick setup of heating tape, it was determined that it would be the most feasible way to heat the circuit. In order to determine the required power input, a heat transfer model was developed to calculate how much power would be needed to maintain the loop at various temperatures.

Because of the high thermal conductivity and high velocity of the liquid metal, the pipe was assumed to be at a constant temperature along its length. The pipe was then treated as a heated cylinder, cooled by natural convection and radiation. While this analysis involved several simplifying assumptions, it provided a “worst-case” scenario as an estimate of the expected range of heat transfer. The governing equations are as follows:

$$Ra_D = \frac{g\beta(T_s - T_\infty)D^3}{\nu\alpha}$$

$$\overline{Nu}_D = \left[ 0.60 + \frac{0.387Ra_D^{1/6}}{\left[ 1 + (0.559/Pr)^{9/16} \right]^{8/27}} \right]^2$$

$$\bar{h} = \frac{k}{D} \overline{Nu}_D$$

$$q' = q'_{conv} + q'_{rad} = \bar{h}\pi D(T_s - T_\infty) + \varepsilon\sigma\pi D(T_s^4 - T_\infty^4)$$

Where properties and constants are calculated at the film temperature, which is the average of the surface and free stream temperatures. Solving these equations at various temperatures produced the relationship between surface temperature and heat flux shown in Figure 13.



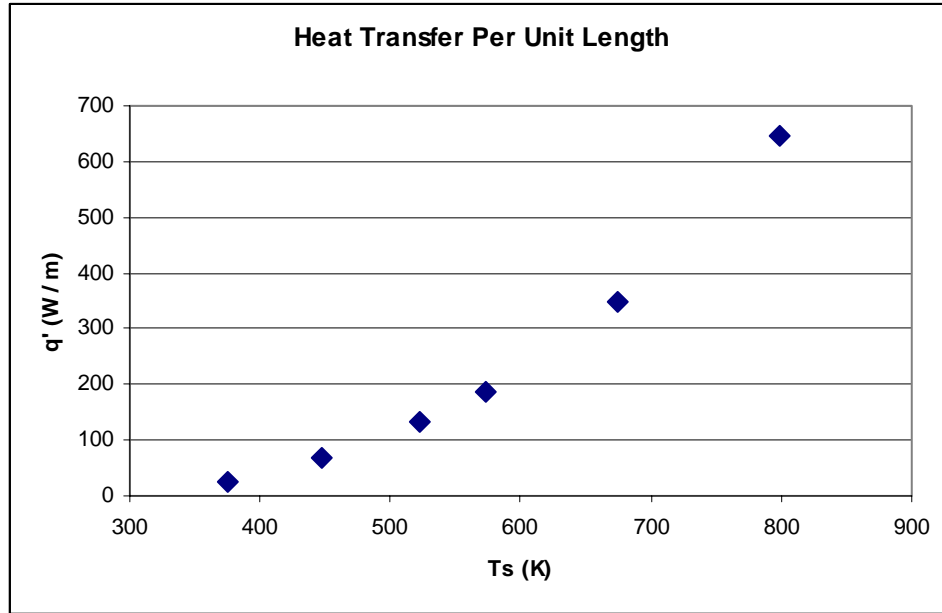

**Figure 13. Relationship between Surface Temperature and Heat Flux**

After looking at this model and the prices of different types of heating tape, two sections of heating tape each 4 feet long and delivering 600 Watts were purchased. The tapes allowed the fluid system to be heated quickly and also to make up for any thermal losses from the heated pipe. Once the heating tape was installed, it was determined experimentally how much current should be applied to maintain a specific desired temperature, using this thermodynamic model as an initial reference (see Appendix C for complete model).

## V. Experimentation

### Testing to Determine Electrode Requirements

In order to determine if large plate electrodes were necessary, the analytical model that was derived from Faraday's law for determining the voltage difference across an electromagnetic flow meter was reviewed. It was not apparent from the model that large plate electrodes would be necessary. Because it was such an important design parameter that directly affected the manufacturing processes which were chosen, it was decided that it would be valuable to run some tests using a prototype called the Racetrack that was made out of acrylic by last year's team. A test was designed that would use large plate electrodes and then copper wire inserts for reading the voltage difference. The testing is shown in Figure 14. Figure 15 shows the test results.

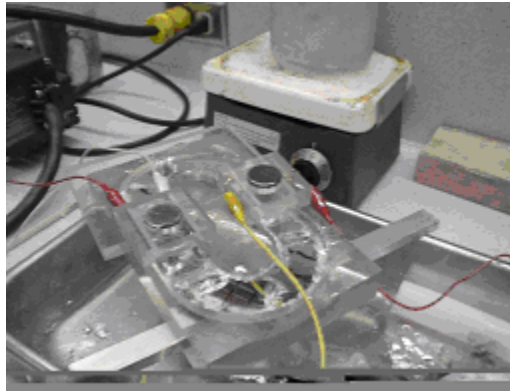

Figure 14. Electrode Testing with Racetrack Prototype

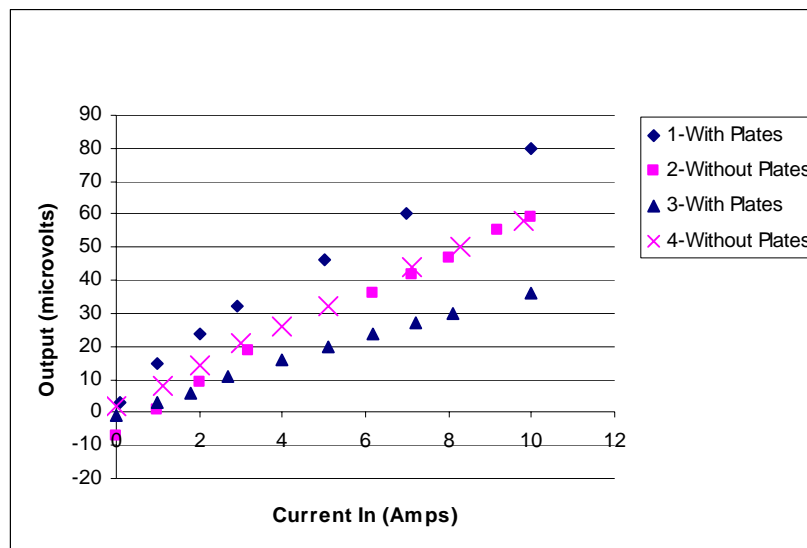

Figure 15. Voltage Output with and without Plate Electrodes

As shown in Figure 15, the results obtained with large plate electrodes had a great deal of scatter. The results obtained using the copper wire inserts were more repeatable. The variation experienced with the use of large plate electrodes was likely due to contact resistance between the plates and the alligator clips attached to them. This experiment gave the confidence needed to proceed in designing a flow meter that did not require the use of large plate electrodes.

## **Corrosion Testing**

The experimental process of testing the flow meter required the use of a metal that had a low melting point and safe levels of reactivity at elevated temperatures. Possible choices for the liquid metal to be used in testing included lead bismuth, lead, NaK (Sodium Potassium), and gallium.

Gallium was the clear choice based on the following criteria:

- Relatively low melting temperature, allowing room temperature tests
- Low toxicity in comparison to the other metals
- Ability to be recycled

One of the major concerns with high temperature testing using gallium is corrosion. Gallium is highly reactive and the level of reactivity changes with temperature. The project's functional specifications include:

- Instrument lifetime of 100 hours
- Operating temperature of 300°C
- Survivability at 800°C.

Candidate materials were tested to determine compatibility with gallium over this range of temperature and duration.

### *Gallium vs. Stainless Steel*

As the test circuit and electrodes are composed of stainless steel, experimentation was needed to discover the reactivity between gallium and stainless steel (see Figure 16).

The experimentation was conducted in a furnace at temperatures ranging from 100 to 800°C. A porcelain crucible was filled  $\frac{3}{4}$  full with gallium and a stainless steel plate measuring  $\frac{1}{8}$ " x  $\frac{15}{16}$ " x  $2 \frac{3}{16}$ " was placed in the gallium. The crucible was held at specified temperatures for approximately 24 hours each, with a total test length of 96 hours. Results were taken between each 24 hour test segment as noted in Figure 16.

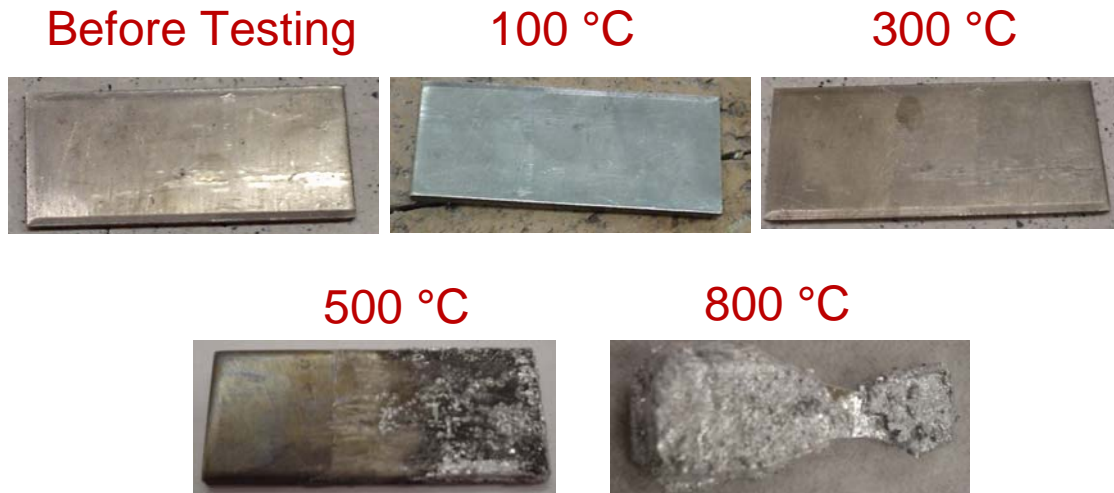

**Figure 16. Stainless Steel Corrosion Test in Liquid Gallium**

Thus, stainless steel is compatible in the testing with gallium up to temperatures of 300°C. Above those temperatures piping and electrodes must be made of different materials.

#### *Gallium vs. Cast Iron*

The positive displacement pump used in the flow loop is made of cast iron. Iron is known to react with gallium at high temperatures. The pump will only be used at temperatures up to 300°C. A corrosion test was conducted to ensure that the gallium would be compatible with the pump.

The experiments were conducted at room temperature in a furnace at temperatures ranging from 100°C to 300°C. The materials were held at each test temperature for 2 hours. A porcelain crucible was filled 1/2 full with gallium and a threaded piece of cast iron was submersed in the liquid. The experiment was conducted at the temperatures noted in Figure 17.

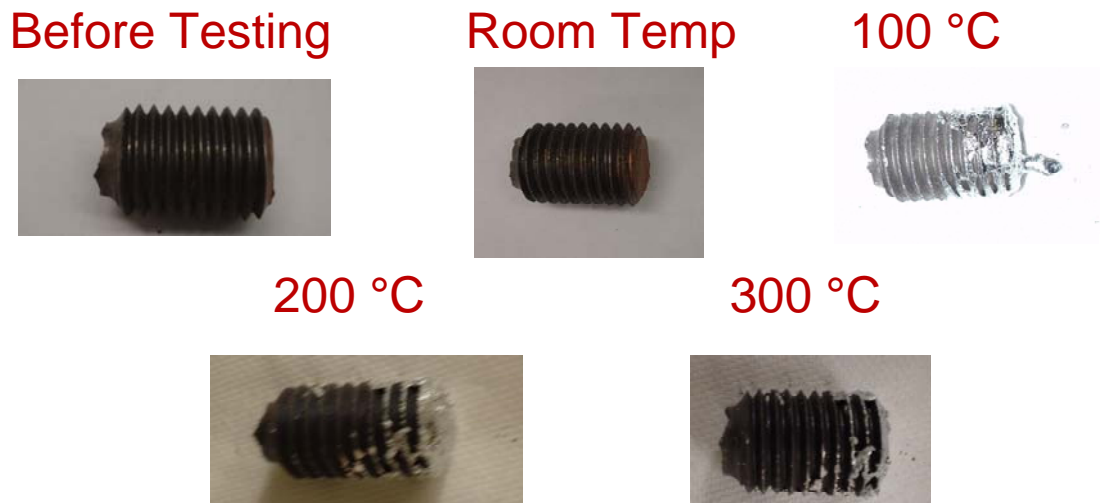

**Figure 17. Cast Iron Corrosion Test**

From the experimentation, it has been concluded that cast iron will not react significantly with gallium at the temperatures and durations required for the project.

### *Gallium vs. Tungsten*

Due to the corrosive nature of stainless steel with gallium, another material had to be used as electrodes in the flow meter. Tungsten was found to be a promising material. It has excellent corrosion resistance. A test was conducted to ensure that tungsten would not react significantly with gallium at elevated temperatures for an extended amount of time.

A porcelain crucible was filled 1/2 full with gallium and a 1/16 inch diameter, 1 inch length tungsten rod was partially submersed in the liquid. The crucible was placed in a furnace at 800°C and sustained at that temperature for 96 hours. After the crucible was removed from the furnace and cooled, the tungsten was still intact, but the end not immersed in the gallium had changed to a yellow-green color with slight cracking and expanded in diameter. This is to be expected considering that the metal oxidizes in air and should be protected at elevated temperatures.

The gallium also had been affected by the test. There was a layer of ash over its surface and a solid wafer of the element almost equal to the diameter of the crucible and approximately a 1/2 inch thick. The tungsten was removed from the gallium, and when dropped a short distance, the yellow-green layer of the tungsten flaked off. The rod was measured and no significant change in dimensions was found.

From this experiment it was concluded that tungsten would work well as electrodes in the flow meter because no reaction was found between gallium and tungsten (see Figure 18).

## After Testing



Ga developed thin ash covering on surface

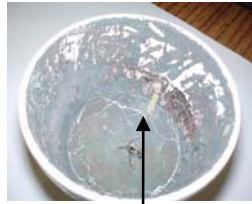

Tungsten developed thin yellow-green layer due to air exposure



Ga wafer present after 96 hour test



Tungsten did not experience significant change in dimensions

**Figure 18. Tungsten Corrosion Test**

### *Gallium vs. Kovar and Graphite*

The flow meter that has been constructed consists of Kovar end pieces. Kovar is a specialty alloy composed of carbon (0.02%), cobalt (17%), iron (53%), manganese (0.3%), nickel (29%), and silicon (0.2%). Also, a graphite paste is used throughout the circuit to seal the joints. To test the reactivity of these materials when exposed to gallium, a Kovar ring coated with graphite paste was inserted into a crucible half filled with gallium. The temperature ranged from 100°C to 800°C. The test was run for a total of 10 hours. The Kovar ring showed signs of corrosion after 1 hour at 800°C (see Figure 19). The Kovar edge immersed in gallium was corroded by approximately 25%. This is not a concern as the meter will only be held at 800°C for a short time period.

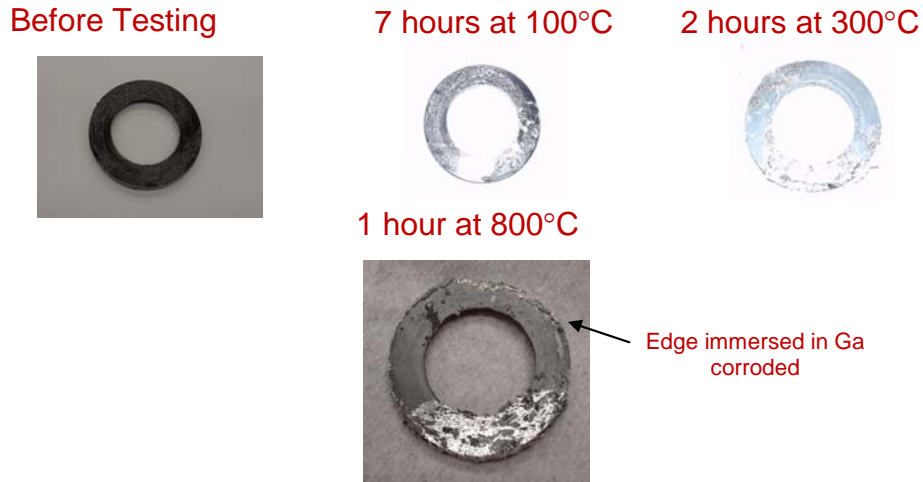

Figure 19. Kovar and Graphite Corrosion Tests

### Ceramic-to-Metal Sealant Test

In order to ensure that the ceramic paste selected, Ceramabond, would provide an adequate bond between the electrodes and the Macor and between the Macor and the Kovar sleeves, a simple test was performed. This test was performed by drilling a hole in a sample piece of Macor and sealing an electrode in the hole. A plate was also sealed to the edge of the Macor sample (see Figure 20). The strength of the bond was determined qualitatively by applying a force to the two seals.



Figure 20. Ceramabond Sealant Test

### Pressure Test

During the acceptance testing, a pressure test was run to determine the accuracy of the head loss model explained in the Analytical Results section of the document. The predicted value for the static pressure of the system was 37 psi. Figure 21 shows the actual pressure obtained using a pressure transducer compared to the headloss model.

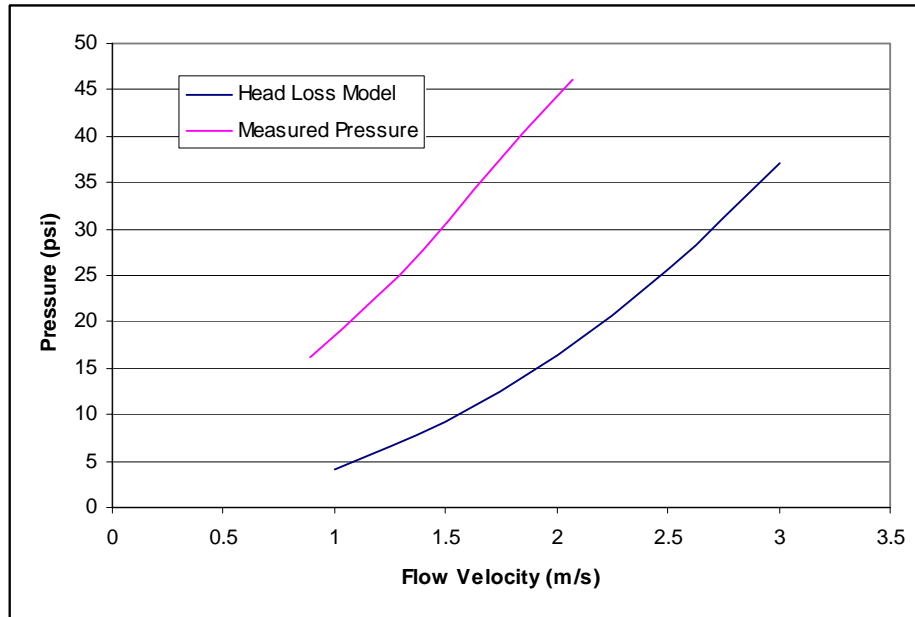

**Figure 21. Pressure in Flow Loop**

The actual pressure was much greater than the pressure predicted by the head loss model. This was in part due to the fact that the pressure transducer was placed at the lowest point in the flow loop. The hydrostatic pressure created by the gallium in the standpipe also helps account for bias between the measured and predicted pressures.

## Flow Rate Test

### *Objective*

In order to validate the final design of the flow meter, a culminating flow rate test needed to be performed. This test was designed to test a variety of the main customer specifications, including:

- 10 hour continuous run capability
- 100 hour life time
- 300° C operation temperature
- Adequate sealing
- $\pm 5\%$  Accuracy

### *Setup*

This experiment was to be performed using the stainless steel flow loop. The piping was sealed using a high temperature graphite compound. The flow was driven by a positive displacement pump (PD pump). This pump was driven by a three phase motor attached to a variable speed controller. This pumping setup allowed easy and accurate control of the RPM of the pump, and thus, accurate control of the volumetric flow rate through the loop



(see Figures 22 and 23). The correlation found between RPM and flow rate shown in Figure 22 was obtained through testing with a Coriolis flow meter. This test was performed using water as the flow medium. It is assumed that the flow rate of water at a given RPM corresponds to the same flow rate of gallium at the same RPM. Heat tape was used to help heat the flow loop, although the pump provided substantial heat by itself.

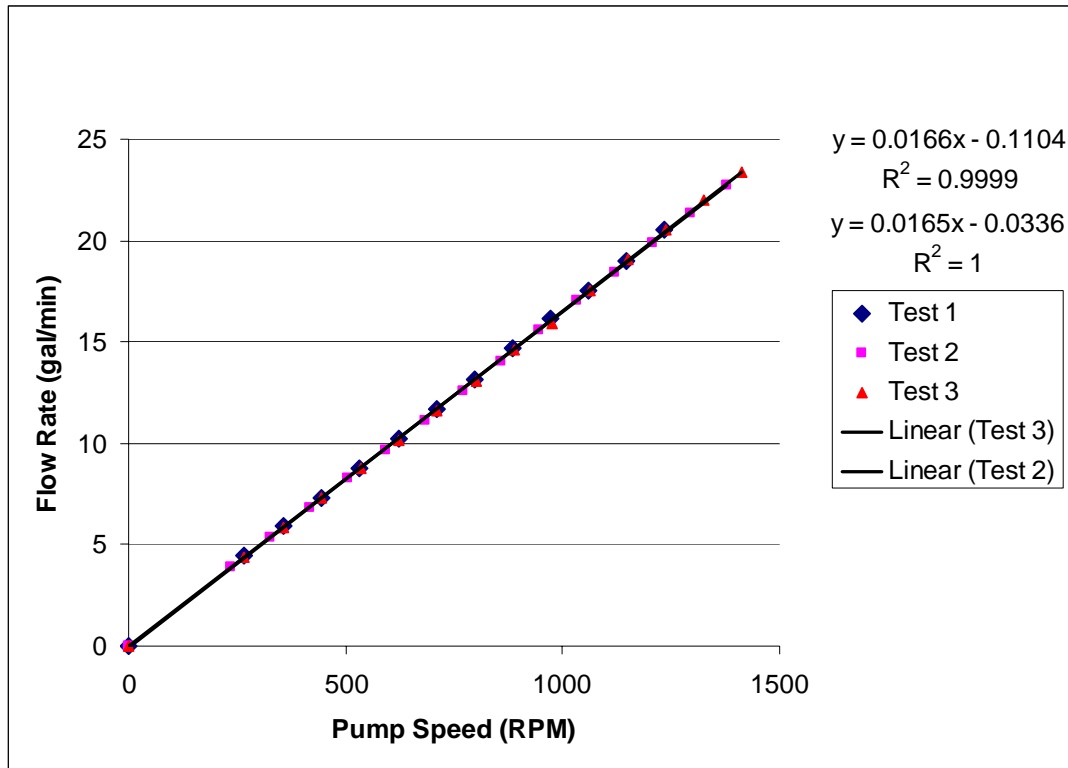
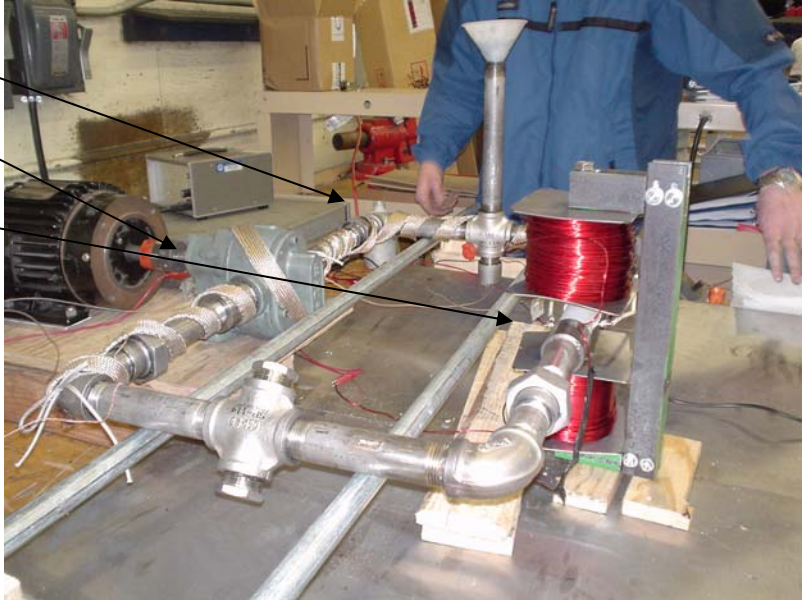

Figure 22. Linear Fit of Flow Rate to Pump Speed

- 1) Stainless Steel Loop
- 2) Positive Displacement Pump
- 3) Flow Meter



**Figure 23. Flow Loop Setup**

A thermocouple was also integrated into the flow loop. The thermocouple was positioned in the loop to have direct contact with the flow media. This enabled accurate temperature measurement throughout the experiment. A pressure transducer was also used during low temperature experiments. The flow meter, with the electromagnet, was placed in the flow circuit opposite the PD pump as shown in Figure 23.

Electrical control for the experiment setup included the RPM control previously mentioned and a variable DC power supply to drive the electromagnet. The thermocouple was attached to a handheld readout meter. The pressure transducer was attached to a handheld voltmeter.

### *Procedure*

The flow loop was filled with liquid gallium. Temperature started at 50° C, was heated up to 293° C, and then cooled back down. Data was taken every 25° C. This was done by ramping the RPM from 400 to 1500. For several points during each ramp, measurements were taken of RPM, voltage output, and temperature. Between temperature increments, the motor was driven at a constant speed around 700-800 RPM. After the full range of temperatures were tested, the flow was then kept at a steady state temperature and run for the remainder of the 10 hours. After the 10 hour test was complete the pump was shut off and the flow stopped. The gallium was kept molten using the heat tape. Flow was then induced and a series of data were taken every 10 to 20 hours for the remainder of the 100 hour test.

There were a few complications with the experimentation. The joints of the flow circuit slowly leaked gallium. Because of this, the flow was stopped periodically to replenish the gallium in the flow loop. Also, in between sessions of data collecting, the

electromagnet was turned off. This inhibited the magnet from reaching thermal equilibrium during testing.

### Results

Figure 24 shows some of the data collected.

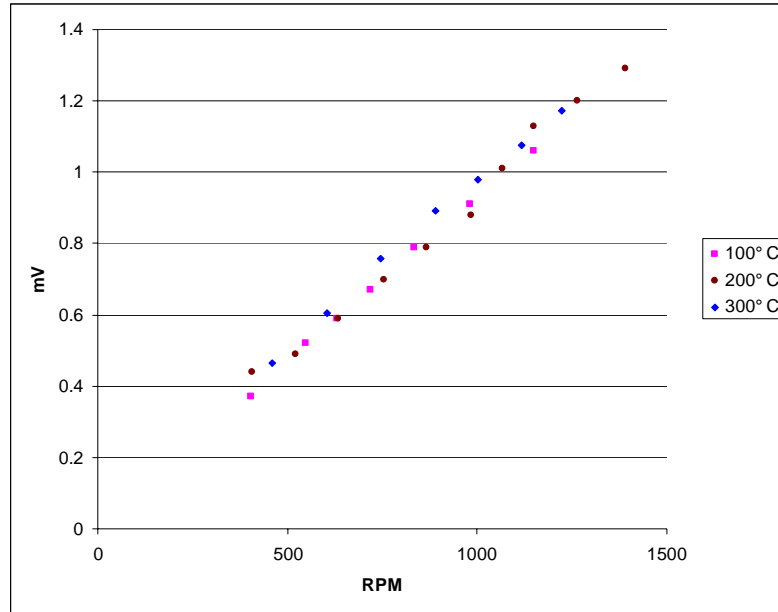

Figure 24. RPM vs. Flow Meter Output (mV) at Three Temperatures

In order to correlate the data to a best fit line and determine the accuracy of the readings, the data was split into two batches. The first set of data was used to develop a model for the flow vs. temperature and voltage. This model is given below:

$$Q = k_1 T + k_2 \varepsilon + k_3$$

Q = Flow rate of the liquid gallium in gpm

T = Temperature in Celcius

$\varepsilon$  = Voltage signal from flow meter (mV)

$$k_1 = -0.0054$$

$$k_2 = 18.692$$

$$k_3 = -0.0355$$

This model differs from the previous analytical model because it was noted that temperature affected the signal voltage. Also, the magnetic field strength was held constant during the testing and was not included in the model. MATLAB's multiple linear regression was used to generate the model.

This model was extremely accurate, with an  $R^2$  value of 98%. The other set of data was used to determine the accuracy of the flow meter compared to the correlation model.

This was done using a binomial distribution. This statistical analysis showed that the overall accuracy of all the data was  $\pm 13\%$ . However, for each individual ramp up, the accuracy was  $\pm 1\%$ .

As for the meter itself, it did exhibit slight leakage at the Kovar joints, but not at the electrodes.

### *Discussion of Results*

Overall this test was a success. The requirements for 10 hour continuous operation, 100 hour life were met. The  $300^\circ\text{C}$  requirement was nearly met with  $293^\circ\text{C}$  being achieved. An adequate seal was also maintained around the electrodes.

The leakage at the Kovar joints can easily be remedied with a larger bore of the Kovar sleeve and a rougher surface finish on the mating Macor. Both of these changes would increase the effectiveness of the ceramic-to-metal bond.

Failure to achieve  $\pm 5\%$  can be accounted for in part by graphite and gallium build up on the electrodes and by variation in the magnetic field due to thermal variations in the coils of the electromagnet. Electronic drift in the flow meter signal was a significant contributor to the inaccuracy.

### *Recommendations*

For future testing the following are suggested:

- Increase clearance in Kovar sleeve for ceramic-to-metal joint
- Roughen surface finish on Macor to increase adhesion of ceramic seal
- Maintain steady state temperature on electromagnet
- Use DC square wave to offset drift
- Increase electrode surface area to minimize contact resistance
- Hold magnetic field strength constant throughout testing
- Use a better sealant for the stainless steel pipe joints

## **800° C Survivability Test**

A Macor tube with tungsten electrode feed-throughs was capped on one end with Kovar and sealed with Ceramabond and Pyropaint. This was filled with gallium and placed vertically in a furnace at  $800^\circ\text{C}$ . Within seconds the Macor shattered due to the sudden increase in temperature. The test was performed again, this time placing the flow meter in the furnace and then heating the furnace to  $800^\circ\text{C}$ . After the required temperature was achieved, the furnace was cooled slowly (with the flow meter inside) over several hours to prevent cracking. The tungsten and Macor seemed to be unaffected, and the seals did not leak.

For further testing at elevated temperatures, it is recommended to heat flow media inside the meter while allowing convection around the outer surface. This would help in determining what temperature gradients can be sustained by the flow meter.

## VI. Alternate Liquid Metal Considerations

In order to adapt the flow meter to other liquid metals, a correlation needs to be determined. However, due to the dangerous and difficult nature of testing with other liquid metals and liquid salts, this could not reasonably be performed in the given timeframe. Through research of this concept it is believed that a major factor of correlation between materials is the electrical resistance. Electrical resistivities for several materials of interest are given as shown in Table 1.

Table 2. Electrical Resistivities of Selected Materials (www.matweb.com)

Material	Electric Resistivity ( $\mu\Omega\text{-cm}$ )	Percent Difference From Gallium
Gallium	17.5	NA
Lead	20.8	18.9%
Sodium	4.1	-77%
NaK	4.1 - 6.6	-77 to -62%
Lead Bismuth (44.5%/55.5%)	43	146%

The exact correlation between resistance and the differences in output voltage of the flow meter would need to be determined experimentally.

## VII. Conclusions

Before the end of winter semester 2006, a high temperature liquid metal flow meter and its electromagnet were designed, produced, tested, and calibrated. The testing that was conducted gave increased understanding of critical characteristics of electromagnetic flow meters. Most of the functional specifications given by the sponsor were met. Valuable information was also gathered about liquid metal flows and measurement techniques. The product that is to be delivered to the sponsor will provide the tools to succeed.

While an accurate flow rate model for the flow meter using gallium in a specific application was found, the use of the final flow meter design in other applications would require recalibration. A simple yet effective method to determine the calibration curve was found which Lockheed Martin could use in the future.

Several key accomplishments of the project are:

- Completed design of electromagnetic pump
- Constructed high temperature, non-intrusive ceramic flow meter
- Complied material property information for:
  - Lead
  - Lead Bismuth
  - Sodium Potassium
  - Liquid Salts
  - Gallium
- Compiled bibliography of research sources
- Conducted flow meter acceptance testing achieving:
  - $\pm 13\%$  Accuracy
  - 10 hours of continuous use
  - Over 100 hours of instrument life
  - Operable at 293°C
  - Survivable to 800°C
- Conducted testing with a ceramic to metal seal
- Constructed, tested, and used a custom electromagnet
- Conducted gallium corrosion testing with:
  - Stainless Steel
  - Cast Iron
  - Tungsten
  - Kovar and Graphite

As this project was a small but important part of a larger research effort, there are several areas in which the sponsor could further research liquid metal flow meters. Potential areas for future research may include:

- Improving ceramic-to-metal seals
- Improving meter accuracy
- Experimenting with different electrode/electrode-less designs that may improve meter accuracy and/or life
- Conducting flow meter testing at elevated temperatures above 500° C
- Conducting flow meter testing with other working fluids to determine their effect on output signals
- Researching and discovering methods of preventing liquid metal leaks



# Appendices

## Table of Contents

Appendix A Bibliography .....	A-1
Appendix B Contacts .....	B-5
Appendix C Analytical Models .....	C-1
Motional EMF.....	C-1
Lorentz Force Law .....	C-1
Thermal Stress Analysis .....	C-2
Fluid Model.....	C-3
Heat Transfer Analysis .....	C-5
Appendix D Material Properties .....	D-6
Properties of Liquid Gallium .....	D-7
Properties of Lead.....	D-10
Properties of Liquid Sodium.....	D-11
Properties of NaK (SODIUM (56%) POTASSIUM (44%)) .....	D-12
Properties of PbBi (LEAD (44.5%) BISMUTH (55.5%)).....	D-13
Properties of Macor.....	D-14
Appendix E Schedule.....	E-15
Appendix F Drawing Package .....	F-16
Appendix G Wiring for Electromagnetic Pump .....	G-20
Appendix H Ceramic to Metal Seal Instructions .....	H-21
Appendix I Functional Specification Report .....	I-22
Introduction.....	I-25
Mission Statement.....	I-26
Customer Needs.....	I-27
Ideal and Target Specifications.....	I-28
Acceptance Test Procedures .....	I-29
Change Procedure .....	I-30
Glossary .....	I-31
References.....	I-31
Bibliography .....	I-32
Appendix J Concept Generation and Evaluation .....	J-33
Introduction.....	J-36
Concept Generation .....	J-36
Concept Evaluation.....	J-38
Selected Concept Explanation .....	J-40
Analysis and Proof-of-Concept Hardware.....	J-40
Appendix J1 .....	J-44
Appendix K Design Proposal Report.....	K-49
Executive Summary .....	K-51
Introduction.....	K-52
Preliminary Design .....	K-52
Concept Justification Analysis.....	K-53
Analytical Pump Model .....	K-55

Concept Justification Hardware and Experimentation .....	K-56
Design Questions .....	K-60
Appendix L Design Analysis and Experimentation Report.....	L-62
Executive Summary .....	L-64
Introduction.....	L-66
Design Questions .....	L-68
Analysis and Experimentation .....	L-72
Prototype Hardware .....	L-77

## Appendix A Bibliography

# MOLTEN Metrix

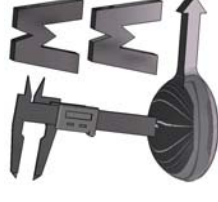

Author	Title	Type	Source	Description
Richard D. Nathanson	Electromagnetic Flow Control Valve for a Liquid Metal with Built-In Flow Measurement	US Patent	USPSTO Patent Full-Text and Image Database	Device uses EM pump in reverse to retard flow of liquid metal in foundries
Roger C. Baker	An Introductory Guide to Flow Measurement	Book	HBLL- TA 357.5.M43 B37	To help understand basic concepts (chap.2 on calibration)
E. Loy Upp & Paul J. LaNasa	Fluid Flow Measurement	Book	HBLL- TA 357.5.M43 U66	Derives equations used to measure flow
Robert B. Ross	Metallic Materials	Book	HBLL- TA 459.R65	Index of materials & their properties
Rolf E. Hummel	Electronic Properties of Materials	Book	HBLL- QC 176.H86	Discusses electric properties in general
Metals Handbook Committee	Metals Handbook Vol.1, 8th Edition	Book	HBLL- TA 459.A5	Comprehensive collection of data on metals
American Society for Metals	Metals Handbook Desk Edition	Book	HBLL- TA 459.A5	Comprehensive collection of data on metals
Atomic Energy Commission	Liquid-Metals Handbook Na-NaK Supplement	Book	HBLL- TA 459.L52	Handbook on properties & uses of Na & NaK. Also discusses Na heat transfer methods & common pumps used with Na.

Atomic Energy Commission	<b>Liquid-Metals Handbook</b>	Book	HBLL- TA 459.L52	Handbook on properties & uses of liquid metals. Also discusses reactive materials & heat transfer methods.
Clifford A. Hampel	<b>Rare Metals Handbook</b>	Book	HBLL- TA 459.H28	Section discussing Gallium includes information on history, derivation, properties, toxicity, alloys, & applications.
David W. Spitzer Walt Boyes	<b>The Consumer Guide to Magnetic Flowmeters</b>	Book	Interlibrary Loan	Includes information on different types of meters & transmitters. Also information on performance, installation, & accessories. Includes list of flowmeter suppliers.
Minoru Takahashi et al	<b>Experimental Study on Flow Technology and Steel Corrosion of Lead-Bismuth</b>	Technical Conference	<a href="http://www.nr.titech.ac.jp/~mtakahas/Erosion.pdf">www.nr.titech.ac.jp/~mtakahas/Erosion.pdf</a>	Discusses steel corrosion with Pb-Bi flow. Authors developed an electromagnetic flowmeter & conducted testing discussed in the text.
Georg Lohöfer	<b>Electrical Resistivity Measurement of Liquid Metals</b>	Technical Journal	<a href="http://www.iop.org/EJ/abstract/0957-0233/16/2/012">www.iop.org/EJ/abstract/0957-0233/16/2/012</a>	Article describes method of measuring electrical resistivity of molten metals. Not extremely helpful.
Friedrich Hofmann	<b>Fundamental Principles of Electromagnetic Flow Measurement</b>	Industrial Brochure	<a href="http://www.krohne.com/html/dlc/index.shtml">www.krohne.com/html/dlc/index.shtml</a>	Very good overview of electromagnetic flow measurement. Good pictures, equations.
eFunda	<b>Introduction to Magnetic Flowmeters</b>	Engineering Website	<a href="http://www.efunda.com/designstandards/sensors/flowmeters/flowmeter_mag.cfm">www.efunda.com/designstandards/sensors/flowmeters/flowmeter_mag.cfm</a>	Includes overview of magnetic flowmeters, necessary equations, specifications, pros & cons
Cole-Parmer Instrument Co.	<b>Selecting the Right Flowmeter</b>	Online Technical Library	<a href="http://www.coleparmer.com/techinfo/techinfo.asp?htmlfile=SelectingFlowmeter2.htm#anchor4">www.coleparmer.com/techinfo/techinfo.asp?htmlfile=SelectingFlowmeter2.htm#anchor4</a>	Includes overview, necessary equations, specifications, pros & cons for various types of flowmeters

Creative Engineers, Inc.	<b>Magnetic Flowmeters</b>	Industrial Brochure	<a href="http://www.creativeengineers.com/Pumps.html">www.creativeengineers.com/Pumps.html</a>	Lists features of meter, compares different models they sell
M.S. Tillack N.B. Morley	<b>Magnetohydrodynamics</b>	Book	<a href="http://mhd.sal.lv/authors/Tillack_M_S.html">mhd.sal.lv/authors/Tillack_M_S.html</a>	Examination of stability calculations for liquid metal film flows in a coplanar magnetic field
Lake Shore Cryotronics, Inc.	<b>Measuring Permanent Magnet Characteristics with a Fluxmeter and Helmholtz Coil</b>	Industrial Article	<a href="http://www.lakeshore.com/magfix/fixmdn.html">www.lakeshore.com/magfix/fixmdn.html</a>	Discusses permeability, flux properties and equations needed for magnet measurement
OMEGA	<b>Flow &amp; Level Measurement</b>	Handbook Excerpt	<a href="http://www.omega.com/literature/transactions/volume4T9904-09-ELEC.html">www.omega.com/literature/transactions/volume4T9904-09-ELEC.html</a>	Compares types of meters & individual components used within them. Notes problems that may occur & how to install.
Roger C. Baker	<b>Solutions of the Electromagnetic Flowmeter Equation for Cylindrical Geometries</b>	Technical Article	<a href="http://www.iop.org/EJ/abstract/0022-3727/11/7/311">www.iop.org/EJ/abstract/0022-3727/11/7/311</a>	A solution is given for the potential distribution around an electromagnetic velocity probe and for the potential in a pipe flowmeter with a magnetic field that doesn't vary in the axial direction.
M.K. Bevir	<b>Theory of Induced Voltage Electromagnetic Flow Measurement</b>	Technical Article	<a href="http://ieeexplore.ieee.org/iel5/20/22908/01066752.pdf?arnumber=1066752">ieeexplore.ieee.org/iel5/20/22908/01066752.pdf?arnumber=1066752</a>	Lays out how each part of flow contributes to a meter signal. Discusses issues to address when designing meter.
Micro Motion, Inc.	<b>Model D and DT</b>	Product Data Sheet	<a href="http://www.emersonprocess.com/micromotion/documentation/index.html">www.emersonprocess.com/micromotion/documentation/index.html</a>	Explains parameters of these mass flow & density sensors (coriolis). Many tables & graphs.
Flexim	<b>The Portable Flowmeter</b>	Product Data Sheet	<a href="http://www.flexim.com/specs/gs6725en.pdf">www.flexim.com/specs/gs6725en.pdf</a>	Discusses parameters of this portable ultrasonic flowmeter
A.A. Sattar	<b>Physical, Magnetic and Electrical Properties of Ga Substituted Mn-Ferrites</b>	Technical Article	<a href="http://www.egmrs.org/EJS/PDF/vo271/99.pdf">www.egmrs.org/EJS/PDF/vo271/99.pdf</a>	X-ray experiments conducted to test properties of Ga. Helpful graphs and images.
P.R. Luebbers	<b>Compatibility of ITER</b>	Technical	<a href="http://ieeexplore.ieee.org/iel3/37">ieeexplore.ieee.org/iel3/37</a>	Corrosion tests conducted and

O. K. Chopra	<b>Candidate Materials with Static Gallium</b>	Conference	<a href="http://90/11107/00534210.pdf?arnumber=534210">90/11107/00534210.pdf?arnumber=534210</a>	results discussed. Measures corrosion based on material & temperature.
Prokhorenko et al	<b>Liquid Gallium: Potential Uses as a Heat-Transfer Agent</b>	Technical article	High Temperature Vol. 38 No. 6 2000	Discusses Ga properties and interactions. Notes materials that will corrode when used w/Ga.
Morgan Advanced Ceramics	<b>Sealing Feedthroughs into Macor Machineable Glass Ceramic</b>	Instructions	<a href="http://www.morganadvancedceramics.com/materials">www.morganadvancedceramics.com/materials</a>	Explains how to seal electrodes into Macor
OMEGA	<b>Magnetic Flowmeters</b>	Industry Reference	<a href="http://www.omega.com/Green/pdf/MAG_FLOW_REF.pdf">www.omega.com/Green/pdf/MAG_FLOW_REF.pdf</a>	Introduces the science behind magnetic flowmeters. Discusses criteria for selection.
R. Gupta et al	<b>A High Field Magnet Design for A Future Hadron Collider</b>	Technical Article	<a href="http://www.bnl.gov/magnets/Staf/Gupta/Publications/">www.bnl.gov/magnets/Staf/Gupta/Publications/</a>	Discusses magnet design in depth
Honeywell, Inc.	<b>Solid State Hall Effect Sensors</b>	Industry Catalog	<a href="http://content.honeywell.com/se/nsing/prodinfo/solidstate/">content.honeywell.com/se/nsing/prodinfo/solidstate/</a>	Discusses sensor's specifications
Hazmat	<b>Guide 153</b>	Safety Document	<a href="http://hazmat.dot.gov/pubs/erg/g153.pdf">hazmat.dot.gov/pubs/erg/g153.pdf</a>	Lists hazards, protective measures, & emergency response protocol
C.M. Andrews	<b>Understanding Permanent Magnets</b>	Technical Article	<a href="http://www.allegromicro.com/techpub2/arnold/tn_9802.pdf">www.allegromicro.com/techpub2/arnold/tn_9802.pdf</a>	In depth discussion of magnet theory & application
C. H. Lefhalm, M. Daubner, R. Stieglitz	<b>Development and Assessment of Flow Rate Measurement Techniques for Lead-Bismuth</b>	Technical Article	P.O. Box 3640, 76021 Karlsruhe, Germany Ph: +49 (7247) 82 6598 <a href="mailto:cord.lefhalm@iket.fzk.de">cord.lefhalm@iket.fzk.de</a>	Research of several Flow measurement techniques of Lead-Bismuth

## Appendix B Contacts



Date	Contact	Affiliation	Address	Website	Email	Phone	Comments
Sep-05	Jim Duncan	Krohne, Inc.	7 Dearborn Road Peabody, MA 01960	<a href="http://www.krohne-mar.com/index.php?id=1922">http://www.krohne-mar.com/index.php?id=1922</a>	info@krohne.com	(978) 535-6060	Krohne specializes in flow control and flow metrics. Jim Duncan gave an overview of electromagnetic flow measurement technology and commented on a few of the problems inherent with high temperature applications of the technology.
Sep-05	Ron Alphin	EESIFLO, Inc.	219 East Main Street Mechanicsburg, PA, 17055	<a href="http://www.eesiflo.com/">http://www.eesiflo.com/</a>	RonAlphin@EESiFlo.US	(866) 337-4356	EESIFLO specializes in ultrasonic flow measurement. Ron Alphin explained that ultrasonic flow measurement requires intimate contact with a sonically conductive pipe housing. A high-temperature ultrasonic meter is available from EESIFLO with a heat sink connector between the pipe and the transmitter/receiver. Max temp for sensor is 200 deg. C. Using a larger heat sink in place of the supplied heat sink may fatally weaken the sonic signal.
Sep-05	Wanliang Sun	University of Alabama-Birmingham			<a href="mailto:swayne@uab.edu">swayne@uab.edu</a>		He heads real time x-raying in the metal casting dept. If we can allow a bubble in our gallium we can track the flow by measuring the speed of the bubble.
Sep-05	Alan Rasmussen	Alcoa Aluminium	Springville, UT	<a href="http://www.alcoa.com/global/en/h">http://www.alcoa.com/global/en/h</a>		(801) 798-4777	Manger of the casting dept @ Alcoa where they do aluminum extrusion, measuring their flow.

Sep-05	John Campbell	University of Birmingham	UK	<a href="#">ome.asp</a>	j.campbell.met@bham.ac.uk	U of B conducts research in real time x-raying of metal casting.
Sep-05	Richard Harding	University of Birmingham	UK			Mick Wickins' (U of B) supervisor
Sep-05	Nick Green	University of Birmingham	UK			Head of the Casting Research Group in the Department of Metallurgy and Materials at the University of Birmingham UK.
Sep-05	Mick Wickins	University of Birmingham	UK		M.Wickins@bham.ac.uk	Mick Wickins heads the research
Jan-06	B. Hammond	Hybrid Tek		<a href="http://www.hybrid-tek.com/">http://www.hybrid-tek.com/</a>	<a href="mailto:bhammond@hybrid-tek.com">bhammond@hybrid-tek.com</a>	Hybrid Tek was willing to quote us on the ceramic flow meter
Jan-06	April & Dan	Dexter Magnetic Technologies, Inc.		<a href="http://www.dextermag.com/Page63.aspx">http://www.dextermag.com/Page63.aspx</a>	dspooner@dextermag.com	Willing to produce an EM. Sent drawings of a design that could work if modified.
Jan-06	Jim Robbins	Latronics Corporation		<a href="http://www.latronicscorp.com/">http://www.latronicscorp.com/</a>	jrobbins@latronicscorp.com	Willing to make ceramic flow meter. Lead time & cost undesirable.
Feb-06	N/A	Morgan Technical Ceramics	26 Madison Rd Fairfield, NJ 07004	<a href="http://www.morganadvancedceramics.com/contact.htm">http://www.morganadvancedceramics.com/contact.htm</a>	(800) 345-4082 (847) 956-1140 (724) 539-1626 ext. 212 (973) 227-8877	Supplier of Macor
Mar-06	Dr. Robert Stieglitz	Karlsruhe Lead Laboratory KALLA	Germany	<a href="http://www.kalla.fzk.de/">http://www.kalla.fzk.de/</a>	<a href="mailto:robert.stieglitz@iket.fzk.de">robert.stieglitz@iket.fzk.de</a>	Head of engineering team who have done liquid metal flow measurement
Mar-	Dr. Cord Lefthalm	Institute for	Germany	<a href="http://www.lefthalm.de/">http://www.lefthalm.de/</a>	<a href="mailto:lefthalm@ip">lefthalm@ip</a> +49	Author of <b>Development &amp; Assessment of Flow</b>



		Dataprocessing and Electronics		<a href="http://fzk.de/fzki/dcplg?ldcservice=FZK&amp;node=0050&amp;lang=en">fzk.de/fzki/dcplg?ldcservice=FZK&amp;node=0050&amp;lang=en</a>	<a href="mailto:e.fzk.de">e.fzk.de</a>	(0)72 47 82-6598	<b>Rate Measurement Techniques for Lead-Bismuth</b>
06							
Mar-06	N/A	Aremco Products, Inc.	707B Executive Blvd Valley Cottage, NY 10989	<a href="http://www.aremco.com/">http://www.aremco.com/</a>	<a href="mailto:aremco@aremco.com">aremco@aremco.com</a>	(845) 268-0041	Supplier of ceramic paste used in meter sealing (Ceramaxbond)
Mar-06	N/A	Payne Engineering		<a href="http://www.payneng.com/">http://www.payneng.com/</a>	<a href="mailto:info@payneng.com">info@payneng.com</a>	(304) 757-7353	This company supplied us with the variac. We communicated with them further to request the user's manual but never received it.
Mar-06	N/A	MWS Wire		<a href="http://www.mwswire.com/">http://www.mwswire.com/</a>		(888) 697-9473	Supplier of 14 AWG wire used in custom electromagnet
Mar-06	Bob Foster	BSM Pump Corp.	180 Frenchtown Rd. N. Kingstown, RI 02852	<a href="http://www.bsmpump.com/">http://www.bsmpump.com/</a>	<a href="mailto:rfoster@bsmpump.com">rfoster@bsmpump.com</a>	(888) 818-4051	Supplier of positive displacement pump

## Appendix C Analytical Models

### *Motional EMF*

$$\mathcal{E} = -B \cdot L \cdot v$$

$\mathcal{E}$  is voltage

B is magnetic field strength

L is the length between the electrodes

v is the velocity of the conductor (fluid)

B  T

L  m

v  m/s

$\mathcal{E}$   V

### *Lorentz Force Law*

$$F = I \cdot L \cdot B$$

F is magnetic force

I is current across channel

L is length between electrodes

B is magnetic field strength

I  A

L  m

B  T

F  N

## Thermal Stress Analysis

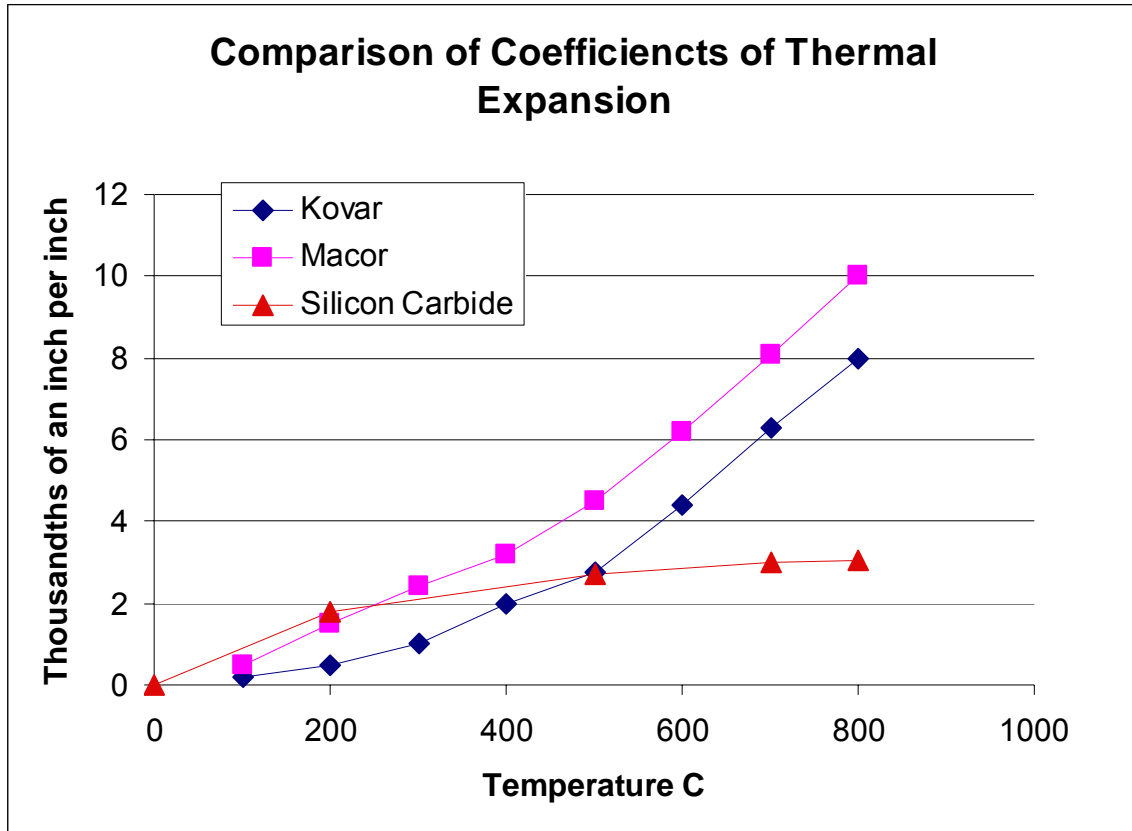

This chart was used to compare the thermal expansion of Kovar, Macor and Alumina, in order to determine which materials to use for the flow meter that would still interface with the stainless steel circuit.

## Fluid Model

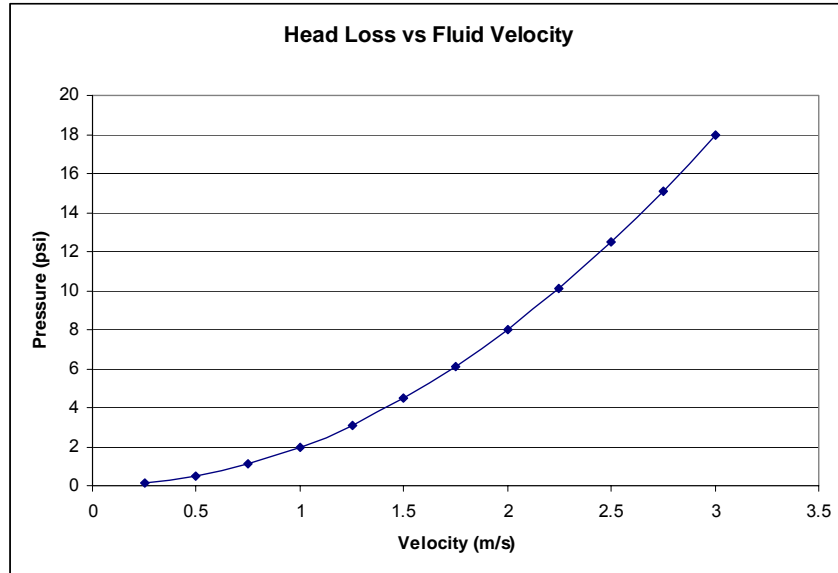

This analysis was performed to determine the internal pressures that could be expected in the flow circuit. This was critical in order to prevent leaks or cracks from forming as high fluid velocities were reached. The table below shows how the head loss was determined:

Velocity 2	3	m/s
Fluid Temp	373	K
Velocity 1	3.141592654	m/s
A2/A1	1.047197551	

pump section		
width(lg)	0.0381	m
height	0.0127	m
length	0.4572	m

Pipe		
diameter	0.0254	m
total length	1.3716	m

Major Losses		
Roughness	0.00004572	m
Density	6071.335995	kg m <sup>-3</sup>
viscosity	0.00158281	N s m <sup>-2</sup>
Reynolds #	292287.6223	
e/D	0.0018	
Friction Factor	0.024	

Minor Losses		
Conical Diffuser		
KL	1.2	
loss	0.604261494	m
Elbows		
# of Elbows	4	
KL	1.5	
loss	2.755102041	m
Valve		
KL	0.15	
loss	0.068877551	m
Nozzle		
A1/A2	0.954929659	
KL	0.05	
loss	0.025177562	m
Total Loss	3.453418648	m

Output		
total Loss	4.246888036	m
pump head	4.28734641	m
pressure head	255093.2217	Pa

Constants		
-----------	--	--

head Loss	0.793469388	m
-----------	-------------	---

gravity	9.8	m s <sup>-2</sup>
---------	-----	-------------------

## Heat Transfer Analysis

In order to determine appropriate heating solutions to raise and lower the temperature of the heating circuit, a heat transfer analysis was performed. Because of the high thermal conductivity and high velocity of the liquid metal, the pipe was assumed to be a constant temperature along its length. The pipe was then treated as a heated cylinder, cooled by natural convection and radiation. The governing Equations are as follows:

$$Ra_D = \frac{g\beta(T_s - T_\infty)D^3}{\nu\alpha}$$

$$\overline{Nu}_D = \left[ 0.60 + \frac{0.387Ra_D^{1/6}}{\left[ 1 + (0.559/Pr)^{9/16} \right]^{8/27}} \right]^2$$

$$\bar{h} = \frac{k}{D} \overline{Nu}_D$$

$$q' = q'_{conv} + q'_{rad} = \bar{h}\pi D(T_s - T_\infty) + \varepsilon\sigma\pi D(T_s^4 - T_\infty^4)$$

Using these equations, it was predicted that the flow circuit would lose approximately 200 watts per meter of pipe. Since the flow circuit was 2 meters in length, it was determined that 400 watts should keep the circuit at 300° C. 600 watts of heating tape was purchased so the temperature could be easily controlled.

## Appendix D Material Properties

Properties of Liquid Gallium .....	D-7
Properties of Lead .....	D-10
Properties of Liquid Sodium.....	D-11
Properties of NaK (SODIUM (56%) POTASSIUM (44%)) .....	D-12
Properties of PbBi (LEAD (44.5%) BISMUTH (55.5%)).....	D-13
Properties of Macor.....	D-14

## Properties of Liquid Gallium

	30 C	300 C	400 C	500 C	600 C	800 C
Atomic Mass	69.72					
Electronegativity	3.2 eV					
Electron Affinity	30 kJ mol <sup>-1</sup>					
Polarizability	8.1 Å <sup>3</sup>					
Density (g/cm <sup>3</sup> )	6.1	5.9			5.7	5.6
Melting Point	29.8 C					
Boiling Point	2237 C					
Specific Heat (J/g)	0.335	0.418	0.418	0.418	0.418	0.418
Electrical Conductivity	3.7 μΩ <sup>-1</sup> m <sup>-1</sup>					
Thermal Conductivity	.07 to .09 cgs					
Coefficient of linear expansion (μin/in.C)	18	11	10.7	10.5	10.2	0.99
Magnetic Susceptibility	.24 μcgs					
Heat of Fusion	19.16 cal/g					
Volume Change on Fusion	-3.10%					
Electric Resistivity	27.2 μΩ					
Dynamic Viscosity (ν) (cP)	2.04	1.03	0.88	0.81		0.652
Surface Tension	735 dynes/cm					

Reactive Materials: Al, Pb, Ti, Cr, Cu, Pt, Zr, Ni, V, Mn, Ag, Au, Ce, Pr, Cd, Fe, Ge, Sn, In  
 Stainless steel  
 (@ 300C+)  
 Inconel  
 Mineral acids  
 Nitric acid

Sodium hydroxide  
 Potassium hydroxide  
 Aqua regia

Note: Under air-free water, Ga stays unaffected for a long period. Dissolvable in HCl or Potassium Hydroxide solution. Corrosion begins @ 400 C. Harmful if inhaled or ingested. Do not use while eating or drinking. Avoid eye contact. Wash hands immediately after contact.



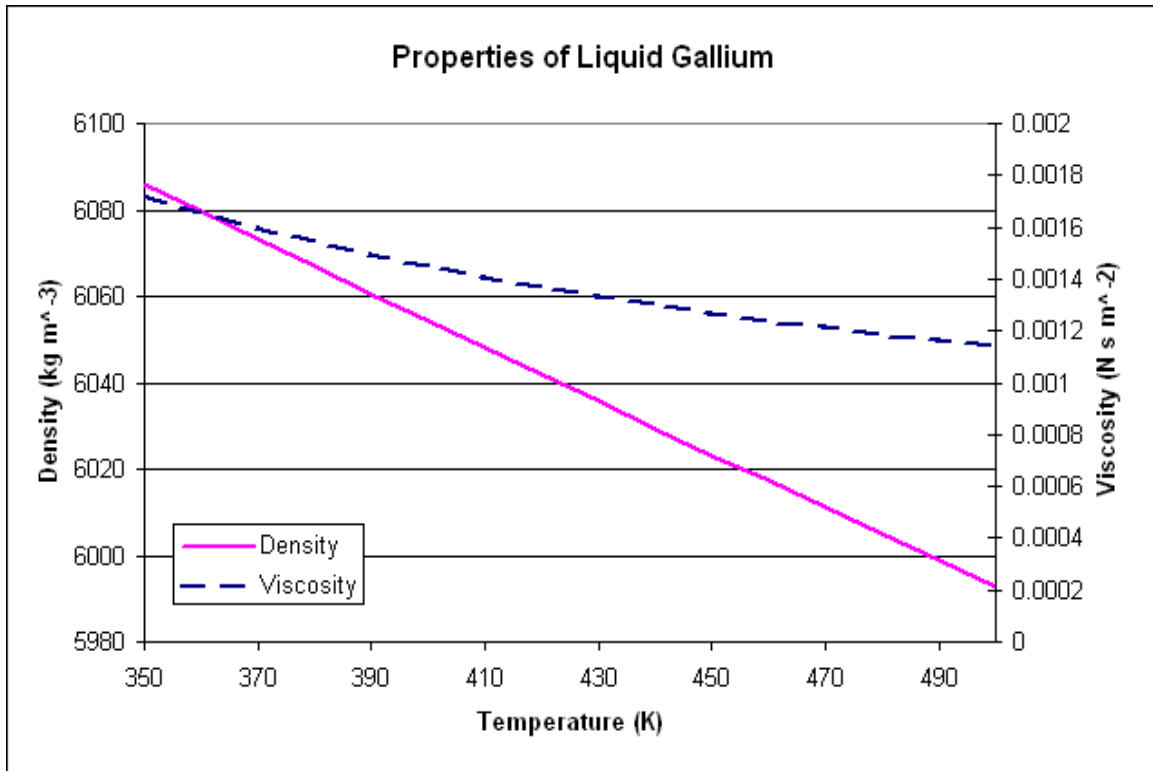

The material properties of gallium depend on temperature, so that  $Gr$  and  $Pr$  are both functions of temperature. Accurate estimates of the viscosity and density of gallium are quoted by Braunsfurth & Mullin (1996). The temperature dependence of the viscosity is given by

$$\eta = 0.4359 \exp\left(\frac{481}{\bar{T}}\right) \times 10^{-3} \text{ N s m}^{-2},$$

and the temperature dependence of density is

$$\rho = (6.32723 - 7.3743 \times 10^{-4} \bar{T} + 1.37767 \times 10^{-7} \bar{T}^2) \times 10^3 \text{ kg m}^{-3},$$

where  $\bar{T}$  is the temperature in Kelvins. However, the dependence of thermal conductivity

of 410 K. So, the density of liquid gallium may be represented by the interpolation equations

$$\rho(\text{kg/m}^3) = 6112 - 0.60(T - T_{mch}) \text{ for } (303-410) \text{ K},$$

$$\rho(\text{kg/m}^3) = 6048 - 0.70(T - 410) \text{ for } (410-700) \text{ K}.$$

## Volumetric Thermal Expansion of Gallium

### § 6. RESULTS

The results in the fifth column of table 1 are given as the ratio  $V_2/V_1$ , where  $V_1$  is the volume of gallium at the initial temperature  $32.38^\circ\text{C}$ . and  $V_2$  is the volume at a higher temperature  $t$ . Values for the coefficient of expansion of the quartz were taken from the tables.

By the method of least squares, the following equation has been found for the ratio  $V_2/V_1$ :

$$\frac{V_2}{V_1} = 0.99587 + \frac{1}{10^6} (128.40t - 0.03780t^2 + 0.00003401t^3 - 0.00000001250t^4) \dots(1).$$

The coefficient of expansion,  $V^{-1} dV/dt$ , was calculated from the above equation, and values for it are plotted against temperature in figure 4. It is also possible to

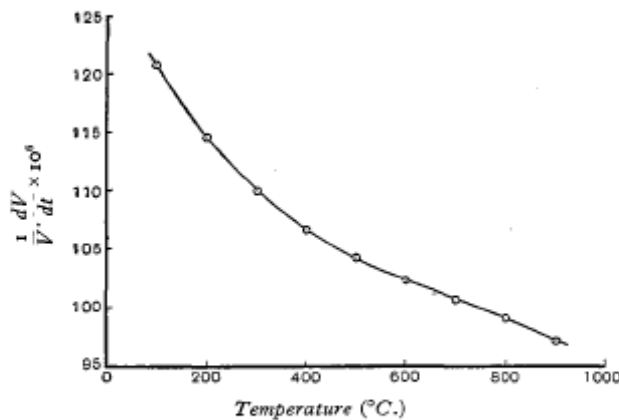

Figure 4.

calculate from equation (1) the mean coefficient of expansion between  $32.38^\circ$  and  $t^\circ$ , defined by  $(V_2 - V_1)/V_1 (t - 32.38)$ ; this has been done for  $t = 310^\circ$ , and the value

## Properties of Lead

	328 C	400 C	500 C	600 C	700 C	800 C
Atomic Mass	207.19					
Electronegativity	2.33 pauling scale					
Electron Affinity	35.1 kJ mol <sup>-1</sup>					
Polarizability	6.8 Å <sup>3</sup>					
Density (g/cm <sup>3</sup> )	10.65	10.51	10.39	10.27		10.04
Melting Point	327.4 C					
Boiling Point	1744 C					
Specific Heat (J/g)	0.163	0.155	0.155	0.138	0.138	0.138
Electrical Conductivity	10600 cm <sup>-1</sup> Ω <sup>-1</sup>					
Thermal Conductivity (cgs)	0.039	0.038	0.037	0.036	0.036	0.0355
Coefficient of linear expansion	28.7 μin/in.C					
Bulk modulus	46 GPa					
Heat of Fusion	26.19 J/g					
Magnetic Susceptibility	-.12 μcgs					
Volume Change on Fusion	3.60%					
Electric Resistivity (μΩ)	94.6	98		107.2		116.4
Dynamic Viscosity (v) (cP)	2.8	2.2	1.9	1.6	1.3	1.2
Relative Permeability	-0.8					
Surface Tension (dynes/cm)	444	438	431			

Reactive Materials: Cr, Hg, C, Mn, Zn, Sn, Cu, W, Ti, Pt, Ni, Co

Acids: Acetic	Antimony chloride	Sulfur dioxide
Hydrochloric	Calcium hydroxide	Nitrobenzol
Citric	Sodium hypochlorite	Nitrochlorbenzol
Nitric	Chlorinated hydrocarbons	Inconel
Organic	Concrete	Monel
Nitrosyl-sulfuric	Ferric chloride	Bronze
Oxy-L	Formaldehyde	Hastelloy
Tartaric	Potassium permanganate	Some stainless steels
	Magnesium chloride	

Caution: Pb is toxic, do not inhale or ingest Pb fumes or dust. Measures should be taken for proper ventilation. Long term exposure to lead or its salts can cause nephropathy & abdominal pains.

## Properties of Liquid Sodium

	100 C	300 C	400 C	500 C	600 C	700 C	800 C
Atomic Mass	23 g/mol						
Electronegativity	0.93 pauling scale						
Electron Affinity	0.5 eV						
Polarizability	24.4 Å <sup>3</sup>						
Density (g/cm <sup>3</sup> )	0.927	0.882	0.859	0.834	0.809	0.783	0.757
Melting Point	97.72 °C						
Boiling Point	883 °C						
Specific Heat (J/g)	1.385	1.305	1.28	1.264	1.255	1.259	1.268
Electrical Conductivity	2.11x 10 <sup>7</sup> /Ω m						
Thermal Conductivity	135 W/m-K	.181 cgs	.170 cgs	.160 cgs	.151 cgs	.143 cgs	.135 cgs
Coefficient of linear expansion	71 μin/in.C						
Bulk modulus	6.3 GPa						
Magnetic Susceptibility	0.51 μcgs						
Heat of Fusion	2.60 kJ/mol						
Electric Resistivity (μΩ)	9.675	17.47	21.99	27.27	32.74	38.77	46.07
Dynamic Viscosity (ν) (cP)	0.705	0.345	0.284	0.243	0.21	0.186	0.165
Surface Tension (dynes/cm)	190.4	170.6	160.8				

Reactive Material: Water, Air @ 115C+

Caution: Sodium's powdered form is highly explosive in water and a poison combined and uncombined with many other elements. This metal should be handled carefully at all times. Sodium must be stored either in an inert atmosphere, or under mineral oil (normally under paraffin or kerosene). Avoid direct skin or eye contact or inhalation of fumes. Don't use fire extinguisher to combat fire. Cover burning Na w/soda ash to suffocate flame. Use alcohol to clean up Na.

### Properties of NaK (SODIUM (56%) POTASSIUM (44%))

	100 C	300 C	400 C	500 C	600 C	700 C	800 C
Atomic Mass	33.9						
Electronegativity	3.2 eV						
Electron Affinity	30 kJ mol <sup>-1</sup>						
Polarizability	8.1 Å <sup>3</sup>						
Density (g/cm <sup>3</sup> )	0.886	0.838	0.814	0.789	0.765	0.742	0.73
Melting Point	19 C						
Boiling Point	825 C						
Specific Heat (J/g)	1.125	1.067	1.05	1.042	1.038	1.046	1.059
Electrical Conductivity	3.7 μΩ <sup>-1</sup> m <sup>-1</sup>						
Thermal Conductivity (cgs)	0.062	0.065	0.066	0.068			0.071
Coefficient of linear expansion	18 μin./in.C						
Magnetic Susceptibility	.24 μcgs						
Heat of Fusion	N/A						
Volume Change on Fusion	2.50%						
Electric Resistivity (μΩ)	35.5	47	62	69	78	88	100
Dynamic Viscosity (ν) (cP)	0.546	0.287	0.23	0.207	0.178	0.161	0.138
Surface Tension	100 to 110 dynes/cm						

Reactive Material: Sb, Bi, Cd, Ca, Au, Pb, Se, Ag, S, Sn, Pt, Al, Si, Mg, Ni, Cu  
 Pyrex glass | Cast iron | Asbestos | Air @ 115C+  
 Water | Nitralloy | Teflon | Hydrocarbon  
 MgO | Brass | Darkoid

Disposal of Small Amount: Treat it w/a current of dry steam.

Disposal of Large Amount: Burn it in a steel pan over open flame while wearing mask to prevent inhalation & protective clothing (rubber-coated suit). Heavy smoke will be produced. If Na catches fire, quickly cool the Na & remove air supply by covering it with salt.

Caution: Avoid direct skin contact. Molten Na causes infectious burns. If burned, flush with water, followed by boric acid, & then water again. Treat burn with a salve containing a sulfa drug. Don't use fire extinguisher to combat fire, instead cover w/soda ash. Clean up w/alcohol. Avoid direct skin or eye contact or inhalation of fumes.

*Properties of PbBi (LEAD (44.5%) BISMUTH (55.5%))*

	125 C	300 C	400 C	500 C	600 C	800 C
Atomic Mass	208					
Density (g/cm <sup>3</sup> )		10.054	10.19	9.79	9.91	9.64
Melting Point	124 C					
Boiling Point	1670 C					
Specific Heat		.146 J/g				
Thermal Conductivity		0.026 cgs				
Volume Change on Fusion	0.00%					
Electric Resistivity (μΩ-cm)	~3	118	123	128		
Dynamic Viscosity (v) (cP)				1.2642	1.1466	
Surface Tension (dynes/cm)						367

Reactive

Materials:

Hg, Pt, Ni

Acids: Acetic

Nitrosyl-sulfuric

Chlorides: Ferric

Nitrochlorbenzol

Calcium hydroxide

Hydrochloric

Organic

Antimony

Sulfur dioxide

Chlorinated hydrocarbons

Citric

Oxy-L

Magnesium

Potassium

Concrete

Nitric

Tartaric

permanganate

Formaldehyde

Sodium

Nitrobenzol

hypochlorite

Inconel

Caution: Pb is toxic, do not inhale or ingest Pb fumes or dust. Measures should be taken for proper ventilation.

## *Properties of Macor*

Max Service Temp	1800°C
Density	2.52 g/cc
Thermal Conductivity	12 BTU in / Hr °F Ft <sup>2</sup>
Thermal Expansion	5.2 x10 <sup>-6</sup> /°F
Compressive Strength	50,000 psi
Flex. Strength	15,000 psi
Modulus of Elasticity	9.3 x10 <sup>6</sup>
Dielectric Strength	1000 volts/mil
Volume Resistivity	10 <sup>14</sup> Ω-cm
Porosity	0%

# Appendix E Schedule

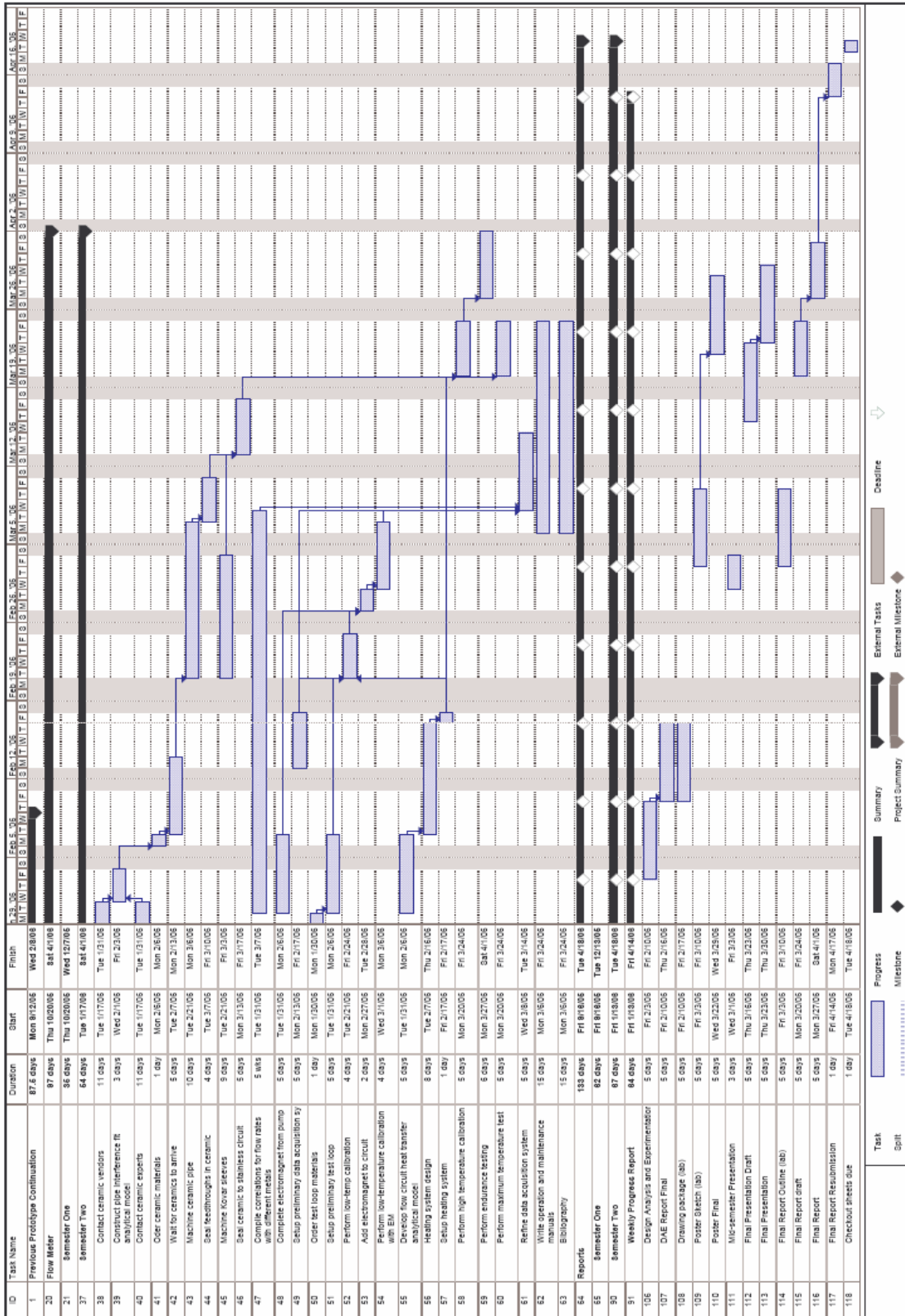



## Appendix F Drawing Package

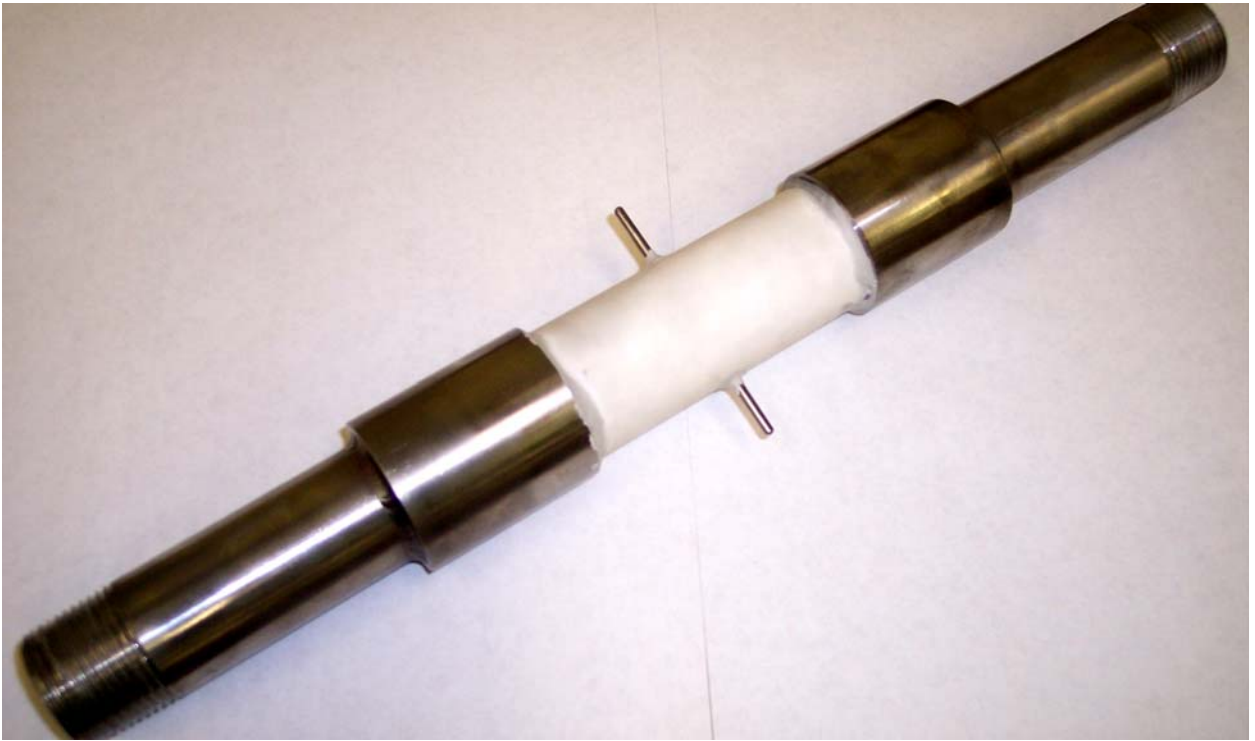

## **Drawing Index**

1. Tentative machining process plans
2. Flow meter
  - a. Flow meter assembly (Bill of Materials)
  - b. Macor ceramic tube (Part 1)
  - c. Kovar interface sleeves (Part 2)
  - d. Tungsten electrodes (Part 3)
3. Electromagnet
  - a. Electromagnet assembly (Bill of Materials)
  - b. Spool/Winding subassembly (Bill of Materials)
    - i. Magnetic pole (Part 4)
    - ii. Inner spool ring (Part 5)
    - iii. Outer spool ring (Part 6)
    - iv. Magnetic spool (Part 7)
    - v. Electrical wiring (Part 8) – Shown as part of wound spool assembly
  - c. Magnetic loop subassembly (Bill of Materials)
    - i. Center support (Part 9)
    - ii. Side supports (Part 10)

## 1. Tentative Machining Process Plans

### Part 1: MACOR Ceramic Tube (25 sfpm)

1. Mount round stock in lathe
2. Center drill end
3. Pre-drill entire length
4. Drill entire length
5. Remove from lathe, mount in mill
6. Center drill side wall
7. Drill through side wall
8. Repeat twice

### Part 2: Kovar Interface Sleeve

1. Mount round stock in lathe
2. Center drill end
3. Pre-drill length
4. Drill length
5. Tap pipe threads
6. Drill opposite end to larger ID
7. Mill flats
8. Remove edges, burrs with file
9. Repeat

### Part 3: Stainless Steel Electrode

1. Cut 1/8" round stock to length with chop saw
2. Sand edges
3. Repeat

### Part 4: Magnetic Pole

1. Face off 1.5" round stock to length
2. Cut 45° chamfer
3. Repeat

### Part 5: Inner Spool Ring

1. Cut 1/16" sheet metal in shear to form a 5" square
2. Remove corners in shear to create an octagon
3. Repeat

### Part 6: Outer Spool ring

1. Follow procedure for part 5
2. Center-punch hole
3. Drill center hole
4. Repeat

### Part 7: Magnetic Spool

1. Cut 3/4" round stock to length

2. Cut 45° chamfer on both ends
3. Drill axial hole to specified depth
4. Remove burrs with de-burr tool
5. Tap threads in axial hole
6. Repeat

#### Part 8: Magnet Wire

1. Cut 14 gauge wire to length
2. Pay special attention to wire insulation, as it is easily removed with any bumping or scraping against hard or sharp objects.
3. Wind wire around assembled spool (parts 4-7). This can be done in a lathe in neutral, turning the turret by hand. Carefully wind one layer at a time and prevent overlapping as much as possible. The wire may be covered in masking tape every few layers to keep a smooth surface.

#### Part 9: Center Support

1. Cut 1.5" square bar stock to length
2. Mill 0.5" slot in both ends
3. Center drill holes with the 1.5" slot
4. Drill holes in the end with the 1.5" slot
5. Mill slots in the end with the larger slot
6. Remove edges and burrs

#### Part 10: End Support

1. Cut 1.5" square bar stock to length
2. Mill 0.5" tongue in one end
3. Center drill holes in tongue
4. Drill holes in tongue
5. Center drill large hole
6. Drill large hole. If drilling is too hard or causes too much tool wear, pre-drill with a smaller diameter drill.
7. Remove edges and burrs.
8. Repeat

REVISIONS		
REV	DESCRIPTION OF CHANGE	DATE
1	INITIAL RELEASE	28 FEB 06

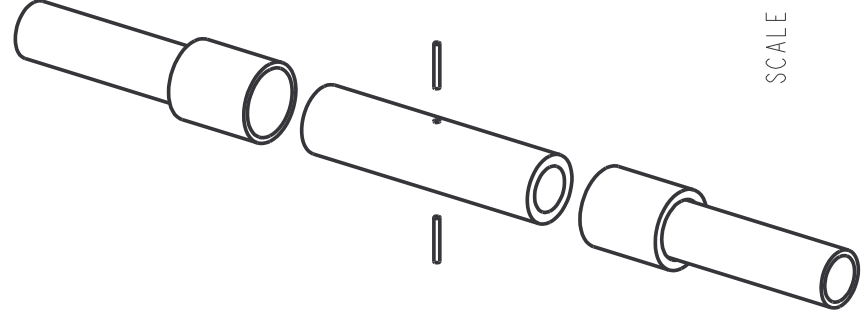
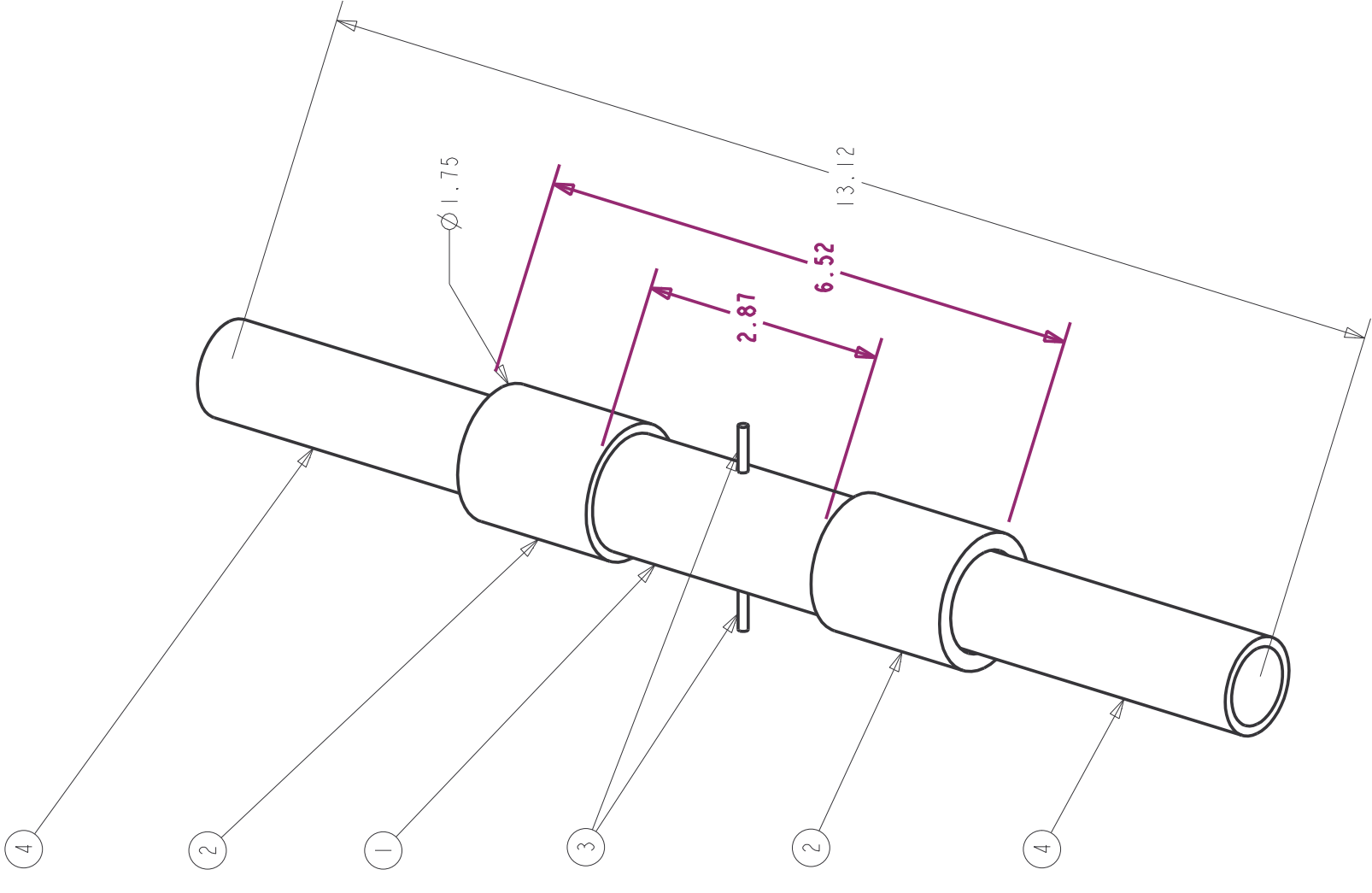

SCALE 0.250

Part #	Part Name / Description	QTY
1	Macor Ceramic Tube	1
2	Kovar Interface Sleeve	2
3	Stainless Steel Electrode	2
4	Stainless Steel Mating Pipes	2

**MOLTEN METRIX**  
CAPSTONE TEAM 14

DIMENSIONS ARE IN INCHES  
 X.XXX ± 0.001  
 X.XX ± 0.01  
 X.X ± 0.1  
 X ± 1

ALL MACHINED SURFACES ✓

THIRD ANGLE PROJECTION ✓

BRIGHAM YOUNG UNIVERSITY  
COLLEGE OF ENGINEERING AND TECHNOLOGY

DRAWN BY C. ANDERSEN	CHECKED BY S. HOOGENDOORN	DATE 14 Apr 06	SCALE 1:2
DATE 14 Apr 2006	CHECKED BY K. TEICHERT	DATE 14 Apr 06	PDM FILENAME FMASSEMBLY2

PART NAME:  
Flow Meter Assembly

DWG SIZE: B  
SHEET 1 OF 1  
DO NOT SCALE DRAWING  
PART NO. Assm  
REV. 1

4

3

2

1

REVISIONS		
REV	DESCRIPTION OF CHANGE	DATE
1	INITIAL RELEASE	28 FEB 06

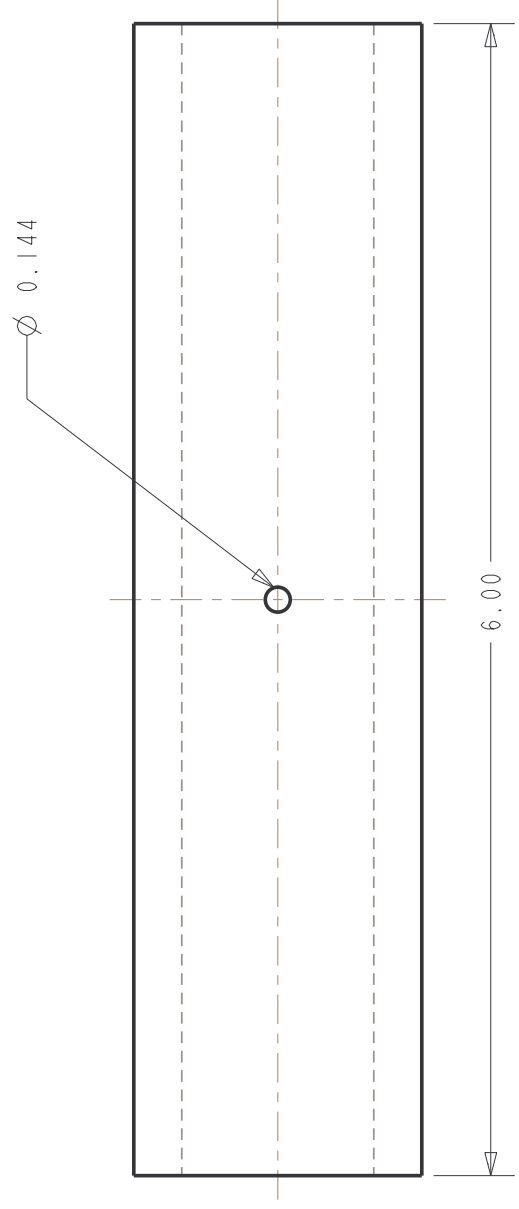
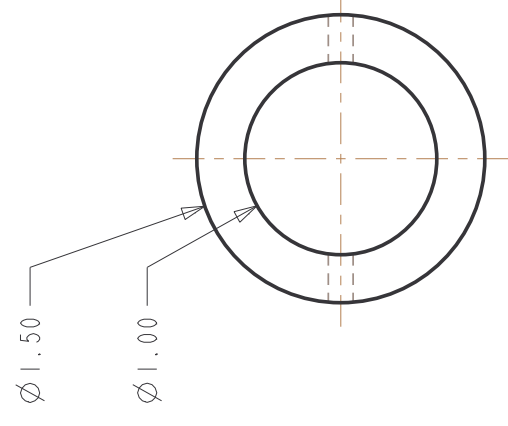

Notes:  
 1. Solid round MACOR stock  
 supplied at Ø1.50" x 6"

<b>MOLTEN METRIX</b>		BRIGHAM YOUNG UNIVERSITY	
CAPSTONE TEAM 14		COLLEGE OF ENGINEERING AND TECHNOLOGY	
DRAWN BY C. ANDERSEN	CHECKED BY S. HOOGENDOORN	DATE 14 Apr. 06	SCALE 1 : 1
DATE 14 Apr. 2006	CHECKED BY K. TEICHERT	DATE 14 Apr. 06	PDM FILENAME CERAMICPIPESECTION
PART NAME: Macor Ceramic Tube			
DWG SIZE B	SHEET 1 OF 1	PART NO.	REV. 1
DO NOT SCALE DRAWING			

ALL MACHINED SURFACES  $\sqrt{63}$

THIRD ANGLE PROJECTION

4

3

2

B

A

B

REVISIONS		
REV	DESCRIPTION OF CHANGE	DATE
1	INITIAL RELEASE	28 FEB 06

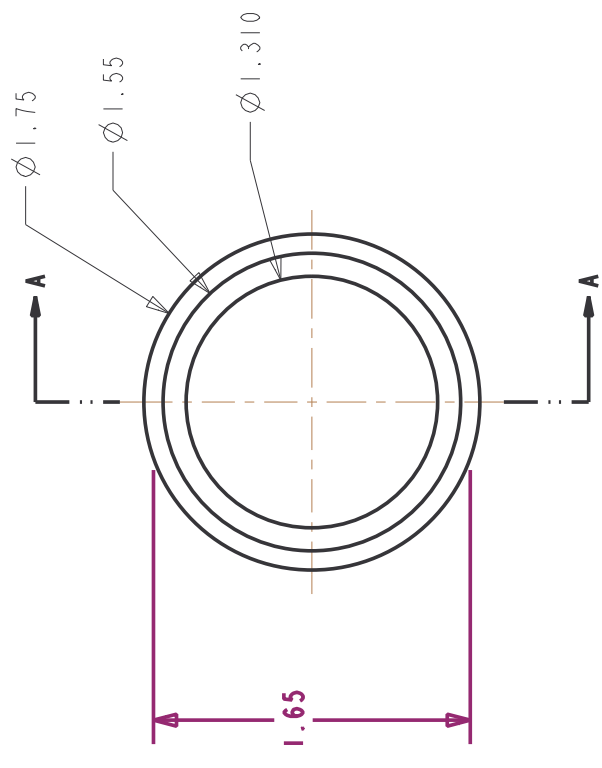
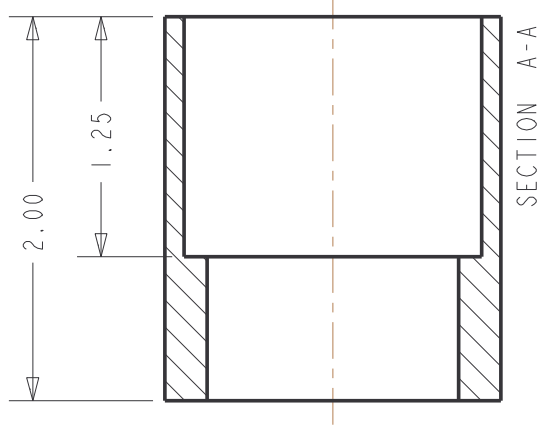

Notes:  
2 required  
Kovar

<b>MOLTEN METRIX</b>		BRIGHAM YOUNG UNIVERSITY	
CAPSTONE TEAM 14		COLLEGE OF ENGINEERING AND TECHNOLOGY	
DRAWN BY C. ANDERSEN	CHECKED BY S. HOOGENDOORN	DATE 14 Apr. 06	SCALE 1:1
DATE 14 Apr. 2006	CHECKED BY K. TEICHERT	DATE 14 Apr. 06	PJM FILENAME KOVAR_SLEEVE
PART NAME: Kovar Interface Sleeve			
DWG SIZE B	SHEET 1 OF 1	PART NO. 2	REV. 1
DO NOT SCALE DRAWING			

DIMENSIONS ARE IN INCHES  
 X.XXX ± 0.001  
 X.XX ± 0.01  
 X.X ± 0.1  
 X ± 1  
 ALL MACHINED SURFACES 63

THIRD ANGLE PROJECTION

4

3

2

1

REVISIONS		
REV	DESCRIPTION OF CHANGE	DATE
1	INITIAL RELEASE	28 FEB 06

B

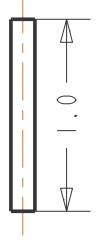
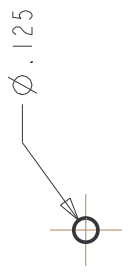

Note:  
2 required  
Tungsten

A



<b>MOLTEN METRIX</b>		BRIGHAM YOUNG UNIVERSITY	
CAPSTONE TEAM 14		COLLEGE OF ENGINEERING AND TECHNOLOGY	
DRAWN BY C. ANDERSEN	CHECKED BY S. HOOGENDOORN	DATE 14 Apr. 06	SCALE 1 : 1
DATE 14 Apr. 2006	CHECKED BY K. TEICHERT	DATE 14 Apr. 06	P1M FILENAME ELECTRODE
PART NAME: Tungsten Electrode			
DWG SIZE B	SHEET 1 OF 1	PART NO. 3	REV. 1
DO NOT SCALE DRAWING			



THIRD ANGLE PROJECTION

ALL MACHINED SURFACES  $\sqrt{63}$

DIMENSIONS ARE IN INCHES  
X.XXX  $\pm$  0.001  
X.XX  $\pm$  0.01  
X.X  $\pm$  0.1  
X  $\pm$  1

2

3

4



1



REVISIONS		
REV	DESCRIPTION OF CHANGE	DATE
1	INITIAL RELEASE	28 FEB 06

B

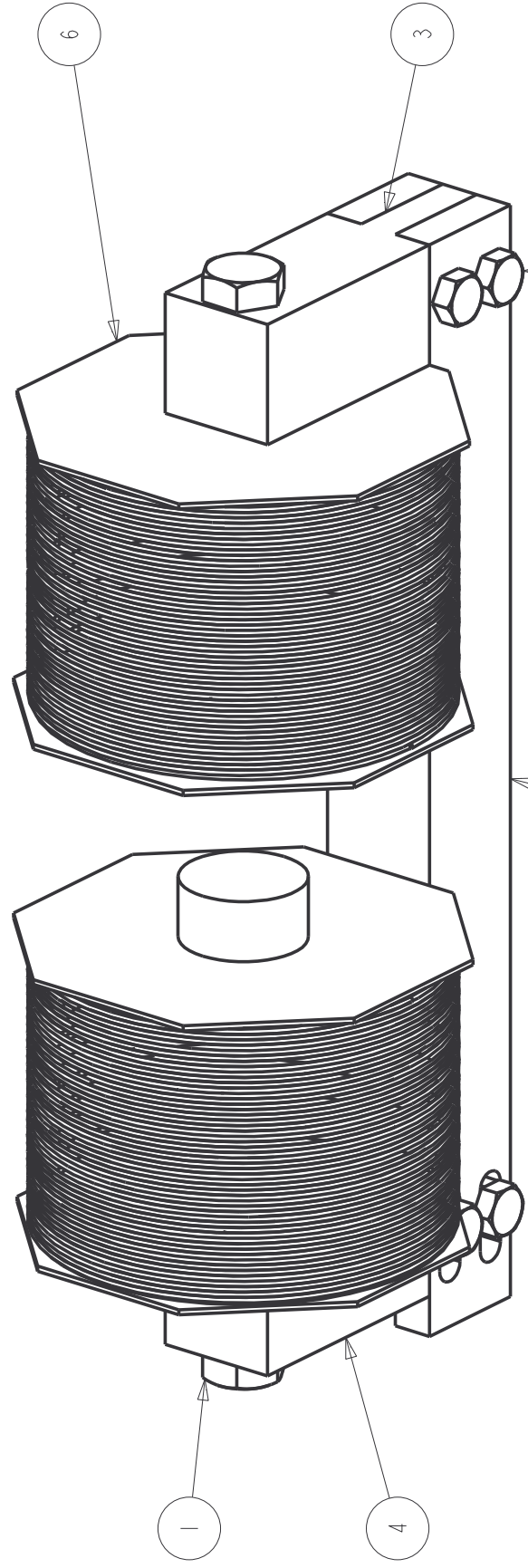

B



A

Bill of Materials		
Part #	Part Name	QTY
1	12-13UNCBOLT	2
2	38-16UNCBOLT	4
3	38UNCNUT	4
4	COREENDPIECE	2
5	MAGCOREBASE	1
6	WOUNDPOOL	2

**MOLTEN METRIX**  
CAPSTONE TEAM 14

DIMENSIONS ARE IN INCHES  
 X.XXX ± 0.001  
 X.XX ± 0.01  
 X.X ± 0.1  
 X ± 1

ALL MACHINED SURFACES <sup>63</sup>

THIRD ANGLE PROJECTION

BRIGHAM YOUNG UNIVERSITY  
COLLEGE OF ENGINEERING AND TECHNOLOGY

DRAWN BY J. WOOD	CHECKED BY S. HOOGEENDOORN	DATE 14 Apr 06	SCALE 1:2
DATE 14 Apr 06	CHECKED BY K. TEICHERT	DATE 14 Apr 06	PDM FILENAME METERMAGNET2

PART NAME:  
Electromagnet Assembly

DWG SIZE  
B

SHEET 1 OF 1 PART NO. ----- REV. 1

DO NOT SCALE DRAWING

2

3

4



1

B

B



A

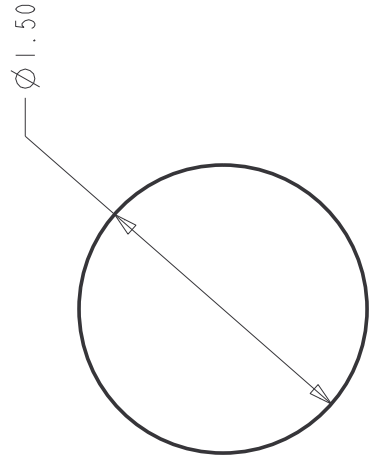

4

3

2

1

REVISIONS		
REV	DESCRIPTION OF CHANGE	DATE
1	INITIAL RELEASE	28 FEB 06

<b>MOLTEN METRIX</b>		BRIGHAM YOUNG UNIVERSITY	
CAPSTONE TEAM 14		COLLEGE OF ENGINEERING AND TECHNOLOGY	
DRAWN BY J. WOOD	CHECKED BY S. HOOGEENDOORN	DATE 14 Apr 06	SCALE 1 : 1
DATE 14 Apr 06	CHECKED BY K. TEICHERT	DATE 14 Apr 06	PTM FILENAME MAGPOLE
PART NAME: Magnetic Pole			
DWG SIZE B	SHEET 1 OF 1	PART NO. 4	REV. 1
DO NOT SCALE DRAWING			

DIMENSIONS ARE IN INCHES  
 X.XXX ± 0.001  
 X.XX ± 0.01  
 X.X ± 0.1  
 X ± 1

ALL MACHINED SURFACES  $\text{63}$

THIRD ANGLE PROJECTION

REVISIONS		
REV	DESCRIPTION OF CHANGE	DATE
1	INITIAL RELEASE	28 FEB 06

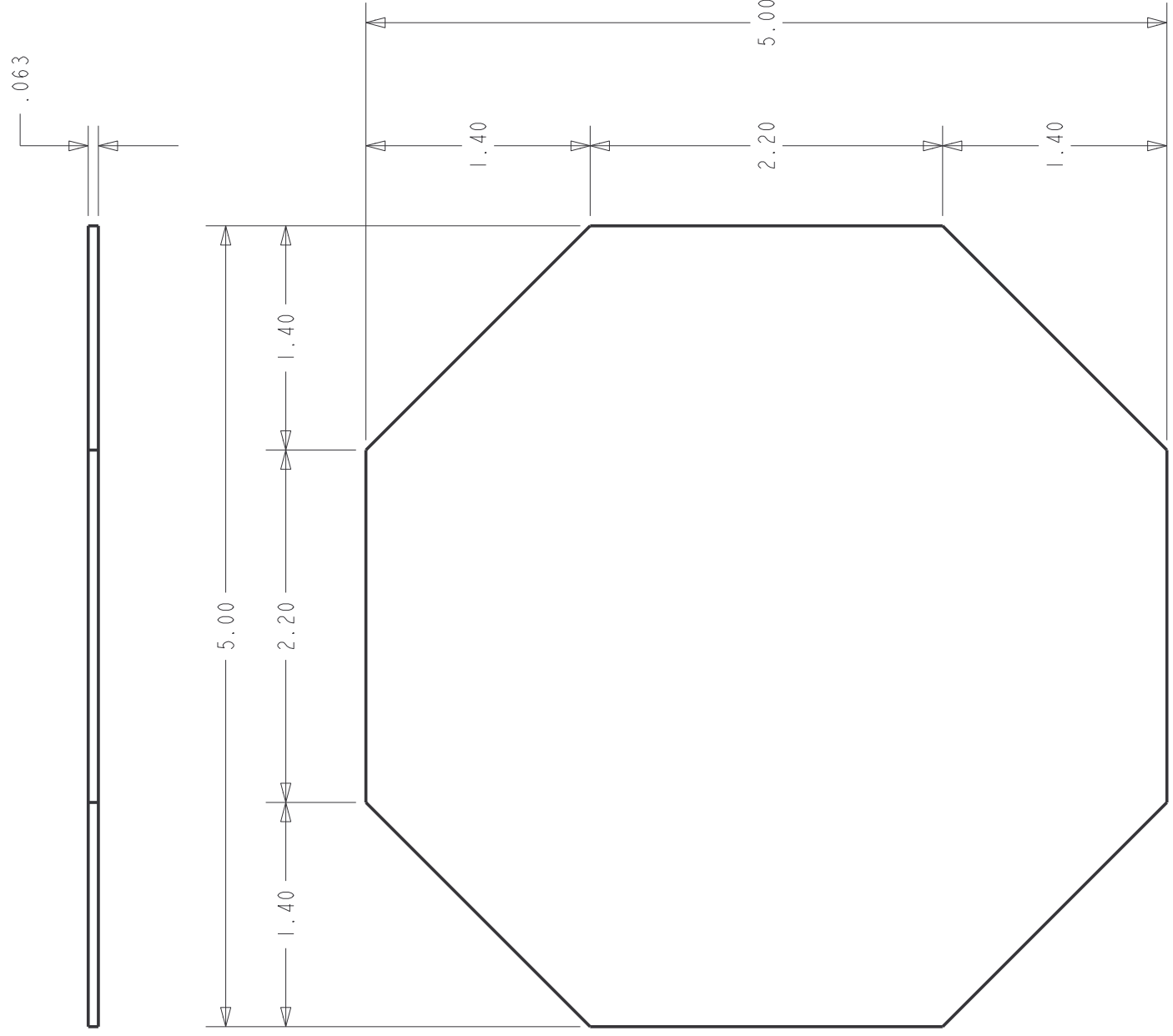

<b>MOLTEN METRIX</b>		BRIGHAM YOUNG UNIVERSITY	
CAPSTONE TEAM 14		COLLEGE OF ENGINEERING AND TECHNOLOGY	
DRAWN BY J. WOOD	CHECKED BY S. HOOGEENDOORN	DATE 14 Apr 06	SCALE 1 : 1
DATE 14 Apr 06	CHECKED BY K. TEICHERT	DATE 14 Apr 06	PTM FILENAME INNERPOOLCAP
PART NAME : Inner Spool Ring			
DWG SIZE B	SHEET 1 OF 1	PART NO. 5	REV. 1
DO NOT SCALE DRAWING			

THIRD ANGLE PROJECTION  
 ALL MACHINED SURFACES  $\sqrt{63}$

4

3

2

B

A

B

REVISIONS		
REV	DESCRIPTION OF CHANGE	DATE
1	INITIAL RELEASE	28 FEB 06

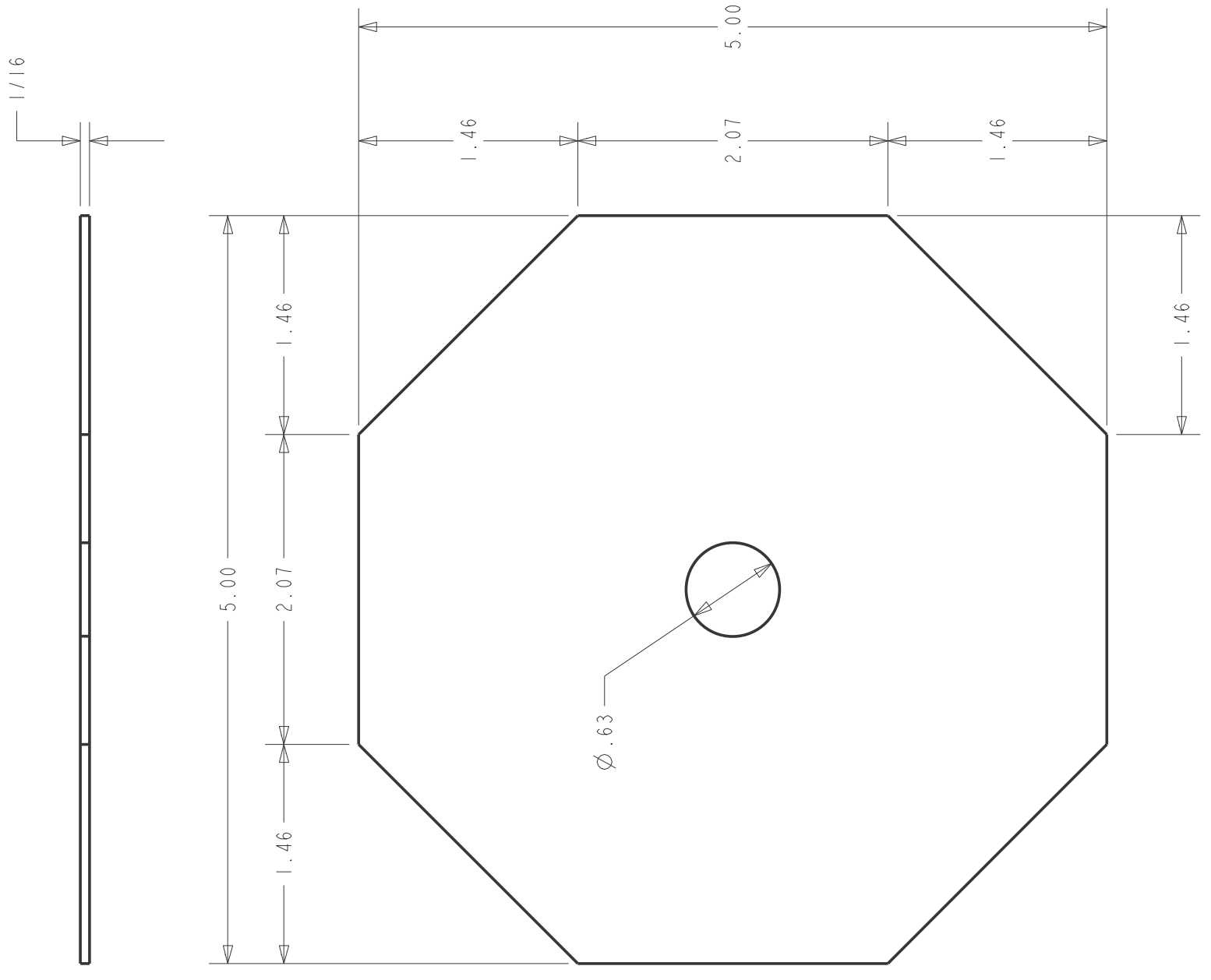

<b>MOLTEN METRIX</b>		BRIGHAM YOUNG UNIVERSITY	
CAPSTONE TEAM 14		COLLEGE OF ENGINEERING AND TECHNOLOGY	
DRAWN BY J. WOOD	CHECKED BY S. HOOGEENDOORN	DATE 14 Apr 06	SCALE 1 : 1
DATE 14 Apr 06	CHECKED BY K. TEICHERT	DATE 14 Apr 06	PTM FILENAME OUTERSPOOLCAP
PART NAME: Outer Spool Ring			
DWG SIZE B	SHEET 1 OF 1	PART NO. 5	REV. 1
DO NOT SCALE DRAWING			

DIMENSIONS ARE IN INCHES  
 X.XXX ± 0.001  
 X.XX ± 0.01  
 X.X ± 0.1  
 X ± 1  
 ALL MACHINED SURFACES  $\sqrt{63}$

THIRD ANGLE PROJECTION

4

3

2

B

A

B

B

B

27/64 DRILL (0.42)  $\nabla$  1.25  
1/2-13 UNC - 2B TAP  $\nabla$  1.00

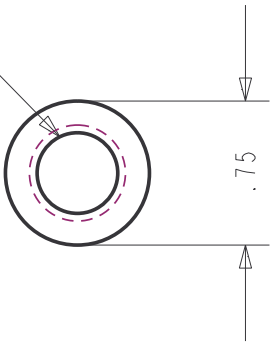

.75

3.50

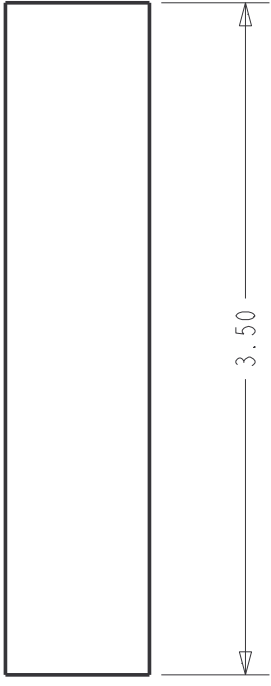

REVISIONS		
REV	DESCRIPTION OF CHANGE	DATE
1	INITIAL RELEASE	28 FEB 06

**MOLTEN METRIX**  
CAPSTONE TEAM 14

DIMENSIONS ARE IN INCHES  
 X.XXX  $\pm$  0.001  
 X.XX  $\pm$  0.01  
 X.X  $\pm$  0.1  
 X  $\pm$  1

ALL MACHINED SURFACES  $\phi$ 3

THIRD ANGLE PROJECTION

BRIGHAM YOUNG UNIVERSITY COLLEGE OF ENGINEERING AND TECHNOLOGY			
DRAWN BY J. WOOD	CHECKED BY S. HOOGEENDOORN	DATE 14 Apr 06	SCALE 1 : 1
DATE 14 Apr 06	CHECKED BY K. TEICHERT	DATE 14 Apr 06	PTM FILENAME SPOOLSHAFT
PART NAME: Magnetic Spool			
DWG SIZE B	SHEET 1 OF 1	PART NO. 7	REV. 1
DO NOT SCALE DRAWING			

4

3

2

1

A



B

B



A

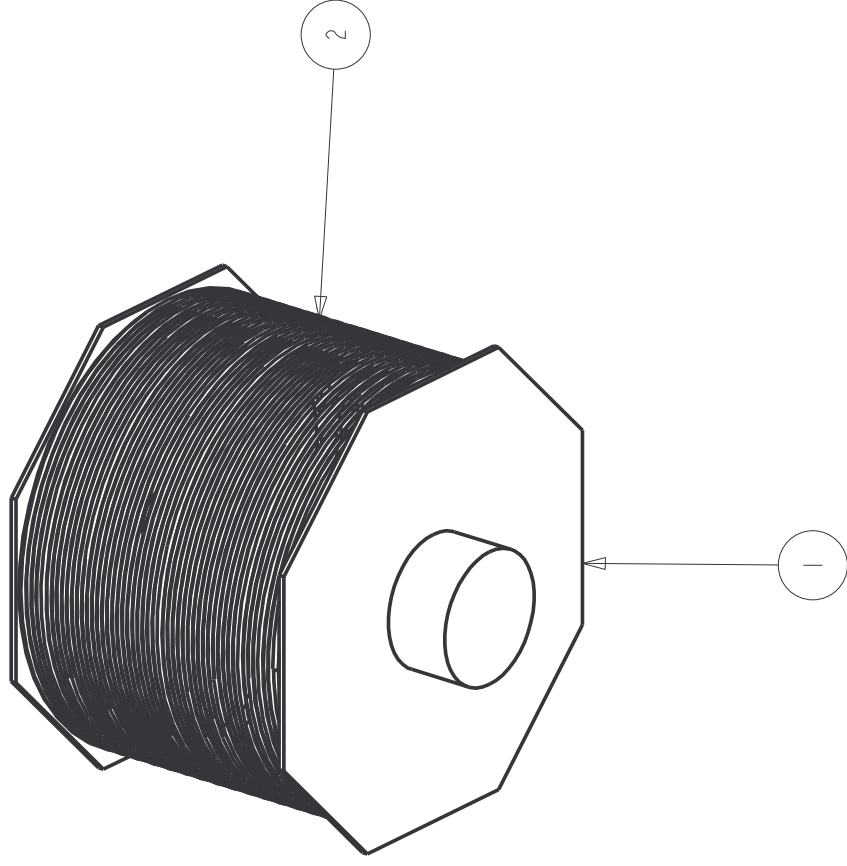

4

3

2

1

REVISIONS		
REV	DESCRIPTION OF CHANGE	DATE
1	INITIAL RELEASE	28 FEB 06

Bill of Materials			
Part #	Part Name	Vendor	Vendor Part # Length
1	SPOOLSUBASSY		
2	WINDINGS	MWS Wire	14-S-PNI55 800 ft

**MOLTEN METRIX**  
CAPSTONE TEAM 14

DIMENSIONS ARE IN INCHES  
 X.XXX ± 0.001  
 X.XX ± 0.01  
 X.X ± 0.1  
 X ± 1

ALL MACHINED SURFACES  $\phi$  63

THIRD ANGLE PROJECTION

**BRIGHAM YOUNG UNIVERSITY**  
**COLLEGE OF ENGINEERING AND TECHNOLOGY**

DRAWN BY J. WOOD	CHECKED BY S. HOOGEENDOORN	DATE 14 Apr 06	SCALE
DATE 14 Apr 06	CHECKED BY K. TEICHERT	DATE 14 Apr 06	PTM FILENAME WOUNDPOOL

PART NAME:  
Wound Spool Assembly

DWG SIZE: B SHEET 1 OF 1 PART NO. --- REV. 1  
DO NOT SCALE DRAWING

B

B

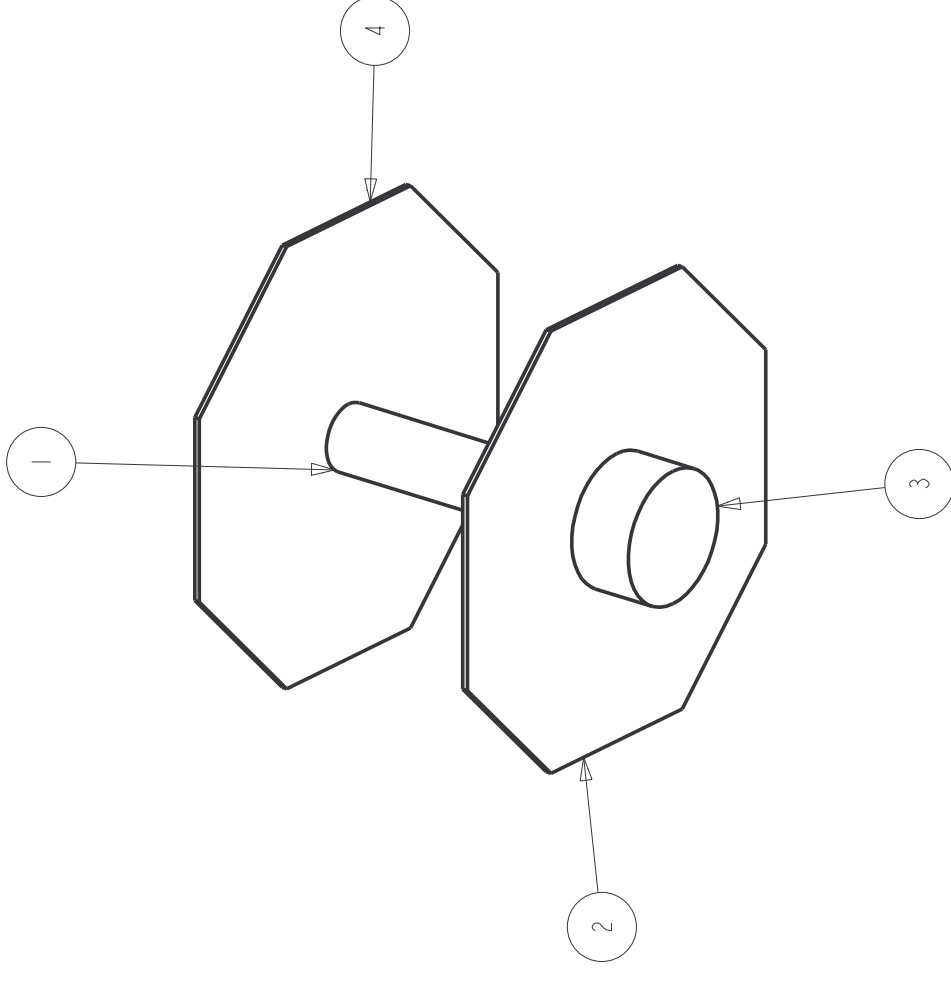

REVISIONS		
REV	DESCRIPTION OF CHANGE	DATE
1	INITIAL RELEASE	28 FEB 06

Bill of Materials		
Part #	Part Name	QTY
1	FMMAGSPOOL	1
2	INNERSPOOLRING	1
3	MAGPOLE	1
4	OUTERSPOOLRING	1

<b>MOLTEN METRIX</b>			
CAPSTONE TEAM 14			
DIMENSIONS ARE IN INCHES			
X.XXX ± 0.001			
X.XX ± 0.01			
X.X ± 0.1			
X ± 1			
ALL MACHINED SURFACES $\phi$ 3			
THIRD ANGLE PROJECTION			
BRIGHAM YOUNG UNIVERSITY COLLEGE OF ENGINEERING AND TECHNOLOGY			
DRAWN BY J. WOOD	CHECKED BY S. HOOGEENDOORN	DATE 14 Apr 06	SCALE 1:2
DATE 14 Apr 06	CHECKED BY K. TEICHERT	DATE 14 Apr 06	PTM FILENAME SPOOLSUBASSEMBLY
PART NAME: Un-wound Spool Assembly			
DWG SIZE B	SHEET 1 OF 1	PART NO. ---	REV. 1
DO NOT SCALE DRAWING			

2

3

4

A

REVISIONS		
REV	DESCRIPTION OF CHANGE	DATE
1	INITIAL RELEASE	28 FEB 06

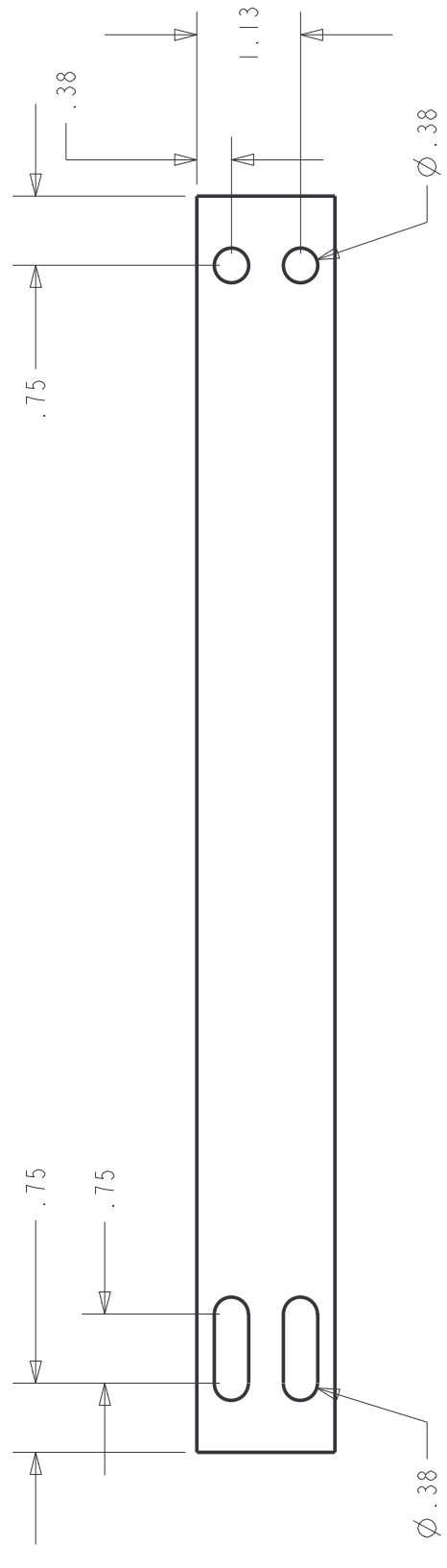
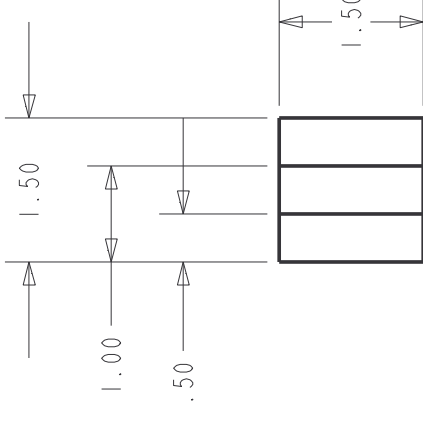
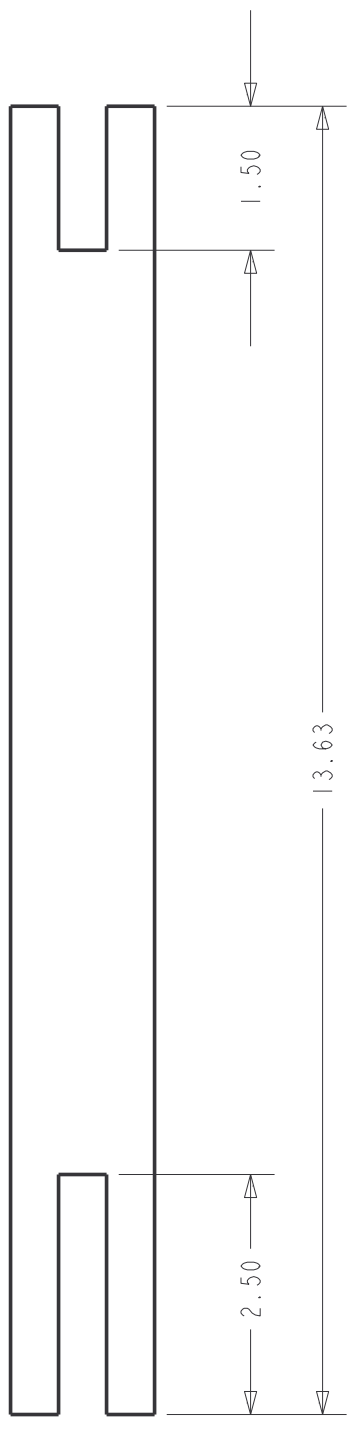

B

A

**MOLTEN METRIX**  
CAPSTONE TEAM 14

DIMENSIONS ARE IN INCHES  
X.XXX ± 0.001  
X.XX ± 0.01  
X.X ± 0.1  
X ± 1

ALL MACHINED SURFACES  $\sqrt{63}$

THIRD ANGLE PROJECTION

BRIGHAM YOUNG UNIVERSITY COLLEGE OF ENGINEERING AND TECHNOLOGY			
DRAWN BY J. WOOD	CHECKED BY S. HOOGEENDOORN	DATE 14 Apr 06	SCALE 1:2
DATE 14 Apr 06	CHECKED BY K. TEICHERT	DATE 14 Apr 06	PTM FILENAME MAGCOREBASE
PART NAME: Center Support			
DWG SIZE B	SHEET 1 OF 1	PART NO. 9	REV. 1

DO NOT SCALE DRAWING

4

3

2



REVISIONS		
REV	DESCRIPTION OF CHANGE	DATE
1	INITIAL RELEASE	28 FEB 06

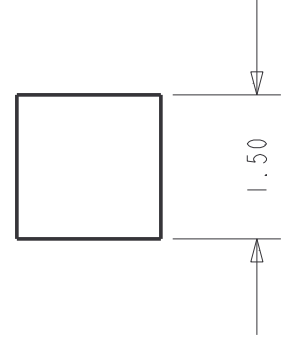

B

B

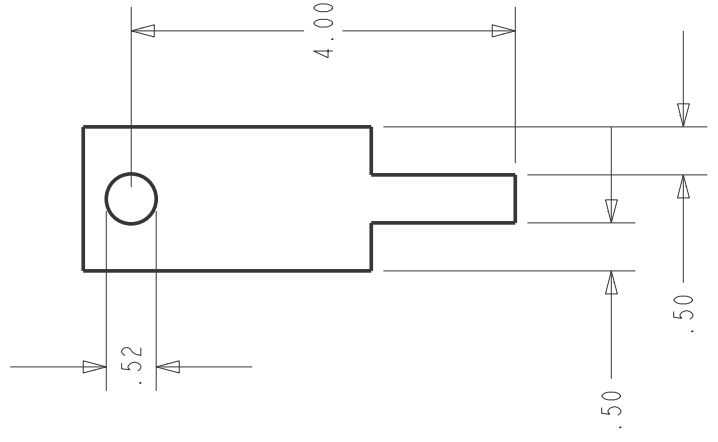
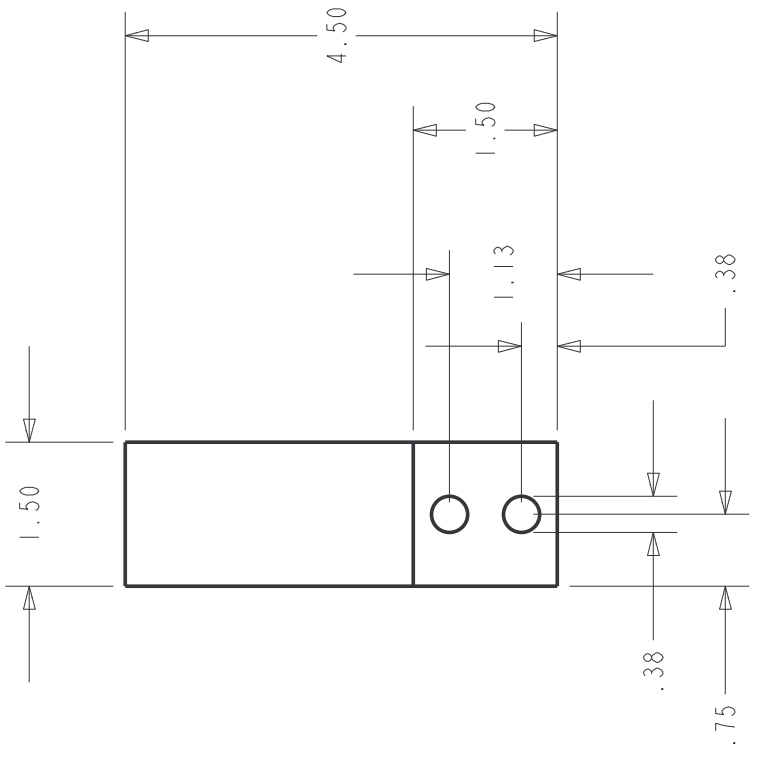

A

<b>MOLTEN METRIX</b>		BRIGHAM YOUNG UNIVERSITY	
CAPSTONE TEAM 14		COLLEGE OF ENGINEERING AND TECHNOLOGY	
DRAWN BY J. WOOD	CHECKED BY S. HOOGEENDOORN	DATE 14 Apr 06	SCALE 1:2
DATE 14 Apr 06	CHECKED BY K. TEICHERT	DATE 14 Apr 06	PDM FILENAME CORENDPIECE
PART NAME: Side Support			
DWG SIZE B	SHEET 1 OF 1	PART NO. 10	REV. 1
DO NOT SCALE DRAWING			

DIMENSIONS ARE IN INCHES  
 X.XXX ± 0.001  
 X.XX ± 0.01  
 X.X ± 0.1  
 X ± 1  
 ALL MACHINED SURFACES  $\sqrt{63}$

THIRD ANGLE PROJECTION

4

3

2

## Appendix G Wiring for Electromagnetic Pump

WARNING HIGH VOLTAGE AND AMPERAGE

Transformer must be covered to avoid electrical shock.

Transformer may heat up, cooling may be needed

Power into Variac — 240VAC, output up to 30 Amps

Power goes from Variac to Transformer (plug together)

From one prong of transformer to backside of Electro Magnet

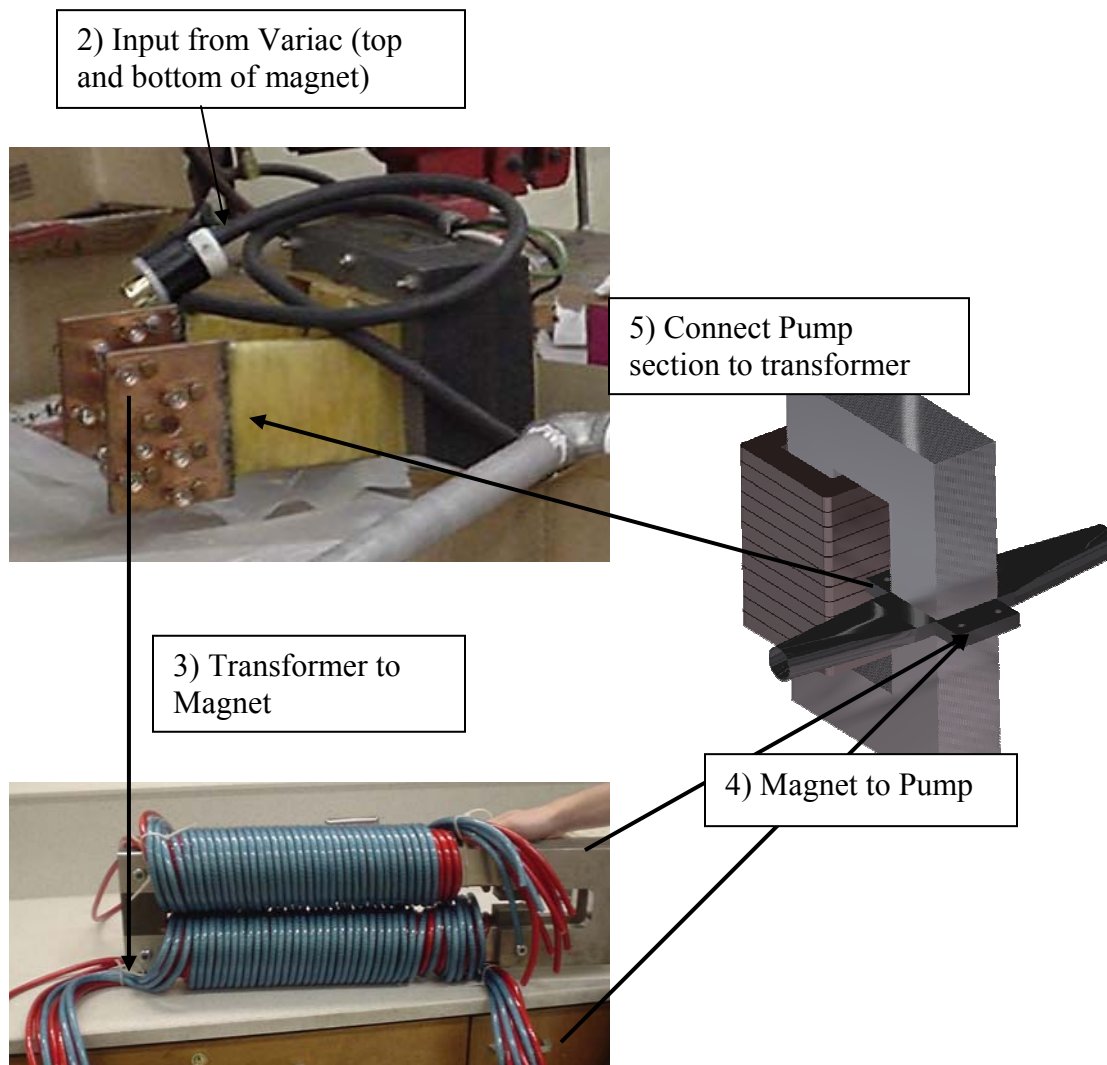

From front of Electromagnet ALL wires connect to one side of EM Pump stainless steel section

Connect an equal number of wires on the output of the pump section as on the input from Magnet. This output then is connected to the other prong of the transformer.

## Appendix H Ceramic to Metal Seal Instructions

- To achieve an effective seal, use a ceramic paste to join the metal to the ceramic
- Follow the application of the ceramic paste with a protective paint to guard against corrosion of the ceramic paste

### Instructions

- Prepare the materials to be joined by ensuring they are clean and dry. In addition, the surfaces of the materials should be abraded to allow the paste to adhere to their surfaces.
- The ceramic paste, Ceramabond, is a 2-part sealant: 571-P and 571-L. These must be used in a 1.5:1 ratio with the 571-P powder being the larger component.
- Pour Ceramabond 571-P powder into mixing container.
- Add Ceramabond 571-L and mix thoroughly. The mixture will harden rapidly. The paste should be applied quickly, joining the materials.
- The joined components must air dry for 1-4 hours.

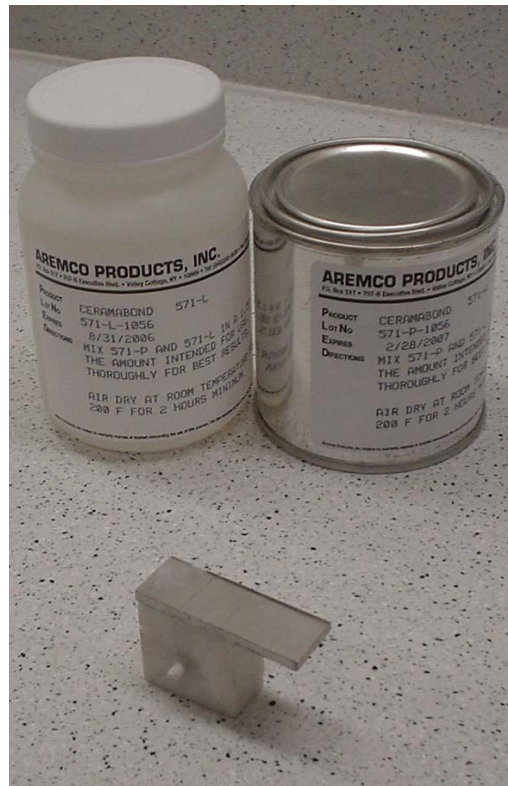

Figure #. Ceramabond

- After the joint is sufficiently dry, fire the part for 1-2 hours at 200° F.
- After the ceramic paste is fired, a protective paint should be applied over the ceramic seal.
- The protective paint, Pyro-Paint, is a 1-part paint, but tends to settle. Before applying it to the seal, stir the paint.
- Apply a 2-3 mil wet film of the paint over the Ceramabond with an applicator.
- The part should again air dry at room temperature for 2 hours
- Conduct a final cure at 200° F for 2 hours before using the part

# Appendix I Functional Specification Report

October 12, 2005

Lockheed Martin-NY  
Liaison: Doug Milone

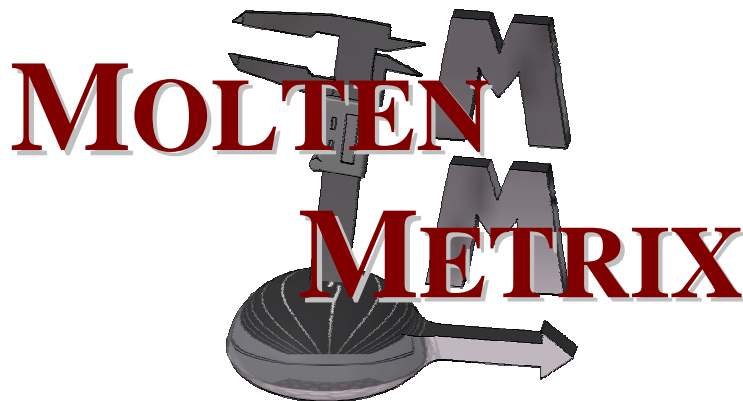

**Group #14**

Cameron Andersen · Summer Hoogendoorn · Ben Hudson  
Joseph Prince · Kendall Teichert · Jonathan Wood

**Capstone Program  
College of Engineering and Technology  
Brigham Young University**

Coach Approval: \_\_\_\_\_

## **Executive Summary**

The purpose of this project is to develop a flow meter for Lockheed Martin that measures the flow rate of molten metal. Customer needs for this product center around accurate and reliable measurements in very high temperature applications. Many prospective technologies require intimate or visual contact with the flow itself, but due to the properties of molten metal flow, leakage is a serious concern. This necessitates the use of non-intrusive metering technology.

In order to develop the best meter possible for this operating environment, target specifications have been determined for the following metrics:

- Operating temperature
- Accurate measurements
- Non-intrusive
- Compatible with different metals
- Continuous operation life
- Instrument life
- Weight
- Size
- Survivability temperature

Achieving these target specifications will ensure customer satisfaction and will enhance flow measurement technology in general.

## Table of Contents

Introduction.....	I-25
Mission Statement.....	I-26
Customer Needs.....	I-27
Ideal and Target Specifications.....	I-28
Acceptance Test Procedures.....	I-29
Change Procedure.....	I-30
Glossary.....	I-31
References.....	I-31
Bibliography.....	I-32

## *Introduction*

The use of molten metals today is very widespread. Casting, electronics, and power are only a few of the industries which are often dependent upon liquid metals. It can be a great struggle to fulfill the requirements for increased efficiency, accuracy and reliability demanded by these modern applications. A robust, accurate liquid metal flow meter plays an integral part in satisfying these demands.

Measuring the flow of liquid metal presents some unique challenges. Typical methods for flow measurement require instrumentation that would be liquefied at the operating temperatures of liquid metals. Furthermore, the high temperature, density and surface tension of most liquid metals make containment a serious functional and safety hazard.

Our assignment is to develop a meter capable of delivering accurate flow measurement despite these challenges. This report will present the mission statement and the fundamental requirements of this project. Customer needs, product specifications, procedures for implementing project changes, and acceptance testing procedures are presented. Finally, a glossary, a list of references, and a detailed schedule are given.

## **Mission Statement**

<b>Mission Statement</b> <b>High Temperature Liquid Metal Flow Meter</b>	
<b>Product Description</b>	Accurate and robust liquid metal flow meter capable of operating non-intrusively at 300° C
<b>Key Business Goals</b>	Serve as a basis for development of future high temperature flow meters
<b>Primary Market</b>	Lockheed Martin
<b>Secondary Market</b>	N/A
<b>Assumptions and Constraints</b>	Non-intrusive measurement of fluid velocity, mass flow rate or volume flow rate Accuracy of ±5% Operating temperature of 300° C (572° F) Survivability at temperatures up to 800°C (1472° F) Minimum continuous operation: 10 hours Minimum instrument life: 100 hours Compatibility with different liquid metals Ability to upgrade to higher temperatures and larger flows
<b>Stakeholders</b>	Lockheed Martin



## Customer Needs

Customer needs have been established, weighted relative to importance, and placed in a hierarchal listing (see Table 1).

**Table 1: Hierarchal listing of customer needs**

No.	Importance	Need
1	5	Meter accurately measures flow
2	5	Meter operates at high temperature
3	5	Meter is non-intrusive
4	5	Meter survives exposure to high temperatures
5	4	Meter is able to be up-scaled to larger flow
6	4	Meter does not require optical access to fluid
7	3	Meter is compatible with different liquid metals
8	3	Meter is able to run continuously for adequate time
9	3	Meter has an adequate overall life time
10	3	Meter has no moving parts
11	2	Meter is compatible with Window's based data acquisition system
12	2	Meter is small
13	1	Meter is light weight

### Explanation of Needs

1 Accuracy of measurement is of critical to this project. The reliability of the measurement is a limiting factor of the design.

2,4 Intended application of the meter necessitates the operation at high temperatures.

3,6,10 Due to the high temperatures and the possibility of leakage, the meter needs to be non-intrusive.

5,7 The meter needs the capability of being up-scaled to higher temperatures and the ability to work with different metals to accommodate various applications of the customer.

8,9 The meter needs to have adequate runtime and lifetime durations in order to justify implementation of projects.

11 Compatibility with a Window's based data acquisition system is required in order to comply with the customer's current technologies

12,13 The flow meter needs to be as small as possible to fit in congested environments.

### *Ideal and Target Specifications*

In order to define the target operational specifications and insure that the customer needs are met, metrics were correlated with needs and assigned acceptable target and ideal values (see Table 2).

**Table 2 Listing of ideal and target specifications of product metrics**

<b>Needs No.</b>	<b>Metric</b>	<b>Acceptable</b>	<b>Ideal</b>
1	Accurate measurements	+/- 8%	+/- 5%
3	Non-intrusive	Pass	Pass
7	Compatibility with different metal	Gallium, Lead	Gallium, Lead, Lead-Bismuth
2, 4	Operation temperature	300° C (572° F)	800° C (1472° F)
10, 3	No moving parts	Pass	Pass
8	Min. continuous operation	8 hrs.	10 hrs.
9	Instrument life	100 hrs.	500 hrs.
13	Weight	<20 lbs	<10 lbs
12	Size	<1 sq. ft.	<0.5 sq. ft.
6	No optical access	Pass	Pass
4	Max. Survivability temperature	800° C	1000° C

## Acceptance Test Procedures

<b>Metric</b>	<b>Verification Test</b>
Accurate measurements	Place traditional flow meter into test circuit to calibrate and test accuracy at various flow rates
Non-intrusive	If meter operates without contact of the fluid and without any leakage paths.
Compatibility with different metal	Determining the limitations with different metals based on properties
Operating temperature	1 <sup>st</sup> option: Contact a foundry that will allow us to use their flow to test the accuracy and operational temperature of our meter. 2 <sup>nd</sup> option: Use vacuum or other furnace to heat loop to target temperature
No moving parts	Pass/Fail
Continuous operation life	Once system is set up, allow meter to run continuously for target time (10 hours) and determine if variation occurs (either by knowing steady flow, or by comparison with traditional flow meter)
Instrument life	Run 4-10 hour tests and determine deterioration of output and extrapolate to target 100 hours
Weight	Weigh with traditional scale
Size	Measure volume
No optical access	No window required
Survivability temperature	Heat test loop to target temperature (either at foundry or in furnace) and then bring back down to operational temperature and determine variation of temperature (either with known flow or with traditional flow meter)

## *Change Procedure*

When our team encounters problems in our specifications or concepts, we will incorporate the following procedure to make changes:

Define the problem. Break down the problem into sub-functions so that the root of the problem is easily identifiable.

Form possible solutions through internal & external research.

Hold a brainstorming session to develop solutions using team synergy.

Rank solutions according to feasibility. Keep in mind parameters such as: time, cost, material, & labor.

After narrowing down the possible solutions to the most promising, we will make our final decision by majority vote, and coach's approval.

OR

If the necessary changes will greatly impact the project as a whole: We will consult our liaison, offering our possible solutions and allow him to make the final decision.

OR

If the necessary changes will impact the Capstone program: We will contact Capstone administration for consultation. Making sure that all affected persons are informed of the changes & supportive of them.

## *Glossary*

**Non-intrusive:** No physical contact with fluid flow

**Gallium:** “A rare metallic element that is liquid near room temperature, expands on solidifying, and is found as a trace element in coal, bauxite, and other minerals. It is used in semiconductor technology and as a component of various low-melting alloys” (answers.com).

## *References*

Lockheed Martin project work statement

Capstone Team 8 '04-'05 reports

Other research was done by last year's team and was compiled into a Bibliography. Continuing research is being done to extend that bibliography and will be provided in the following section.

## *Bibliography*

Hofmann, Friedrich. “Fundamental Principles of Electromagnetic Flow Measurement.”

[http://www.krohne-mar.com/fileadmin/media-lounge/PDF-Download/Magmeters/HB\\_MID\\_e.pdf](http://www.krohne-mar.com/fileadmin/media-lounge/PDF-Download/Magmeters/HB_MID_e.pdf).

Lohöfer, Georg. “Electrical Resistivity Measurement of Liquid Metals.” *Measurement Science and Technology* 16 (2005) 417-425.

Nathenson, Richard D. “Electromagnetic Flow Control Valve for a Liquid Metal with Built-In Flow Measurement.” (November 27, 2001) *US Patent No. 6,321,766*.

Washington, DC: U.S. Patent and Trademark Office.

# Appendix J Concept Generation and Evaluation

November 4, 2005

Lockheed Martin-NY  
Liaison: Doug Milone

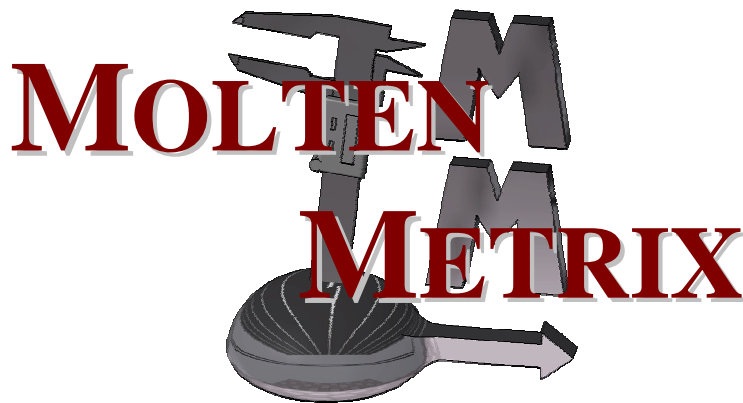

## Group #14

Cameron Andersen · Summer Hoogendoorn · Ben Hudson  
Joseph Prince · Kendall Teichert · Jonathan Wood

**Capstone Program**  
**College of Engineering and Technology**  
**Brigham Young University**

Coach Approval: \_\_\_\_\_

## **Executive Summary**

The purpose of this project is to develop a flow meter for Lockheed Martin that measures the flow rate of molten metal. Key functional specifications for this project include  $\pm 5\%$  accuracy,  $300^\circ$  operating temperature,  $800^\circ$  survivability temperature, 10 hour continuous run time, and 100 hour instrument life. Many prospective technologies require intimate or visual contact with the flow itself, however due to the properties of molten metal flow, leakage is a serious concern. This necessitates the use of non-intrusive metering technology.

A number of different concepts for measuring molten metal flow have been found and developed, including x-ray radiology, electromagnetic, ultrasonic, coriolis, and a simple venturi tube. Selection criteria were chosen (i.e. cost, accuracy, temperature range, etc.) by which each concept was rated. After screening all concepts, the two highest scores (electromagnetic and ultrasonic) were then tested again with weighted importance of the selection criteria. The conductive electromagnetic flow meter scored better than the other concepts and consequently has been selected for more extensive development.



# **Table of Contents**

**Executive Summary J-34**

**Introduction J-36**

**Concept Generation J-36**

**Concept Evaluation J-38**

**Selected Concept Explanation J-40**

**Analysis and Proof-of-Concept Hardware J-40**

**Appendix H1 J-44**

## *Introduction*

The use of molten metals today is very widespread. Casting, electronics, and power are only a few of the industries which are often dependent upon liquid metals. It can be a great struggle to fulfill the requirements for increased efficiency, accuracy, and reliability demanded by these modern applications. A robust, accurate liquid metal flow meter plays an integral part in satisfying these demands.

Measuring the flow of liquid metal presents some unique challenges. Current products use ultrasonic, electromagnetic, and other technologies to measure flow, but the majority of these cannot operate at significantly high temperatures. Furthermore, the high temperature, density, and surface tension of most liquid metals make containment a serious functional and safety hazard.

This purpose of this project is to develop a meter capable of delivering measurements with  $\pm 5\%$  accuracy, with a  $300^\circ$  operating temperature,  $800^\circ$  survivability temperature, 10 hour continuous run time, and 100 hour instrument life. This report will present the methodology that was used both to generate concept designs and to select the most feasible flow meter concept.

## *Concept Generation*

In order to find the concept that best met the functional specifications of this project, the overarching task of developing a flow meter was broken down into inputs and outputs of a flow measurement system.

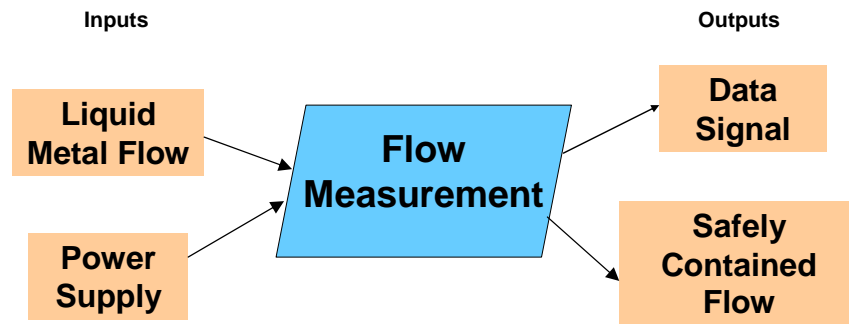

**Figure 1. Liquid metal flow meter functional decomposition**

Figure 1 shows the different components of the project represented as inputs and outputs of the flow measurement system. The system itself will eventually need to be broken down further after concept selection, to identify points of future focus.

Various concepts for the flow meter were generated. Different methods were employed to enhance the team’s ability to find the most diverse set of concepts possible. These included the searching of patents, communication with lead users, study of published literature, and an observation of the specifications of existing flow meters.

During the concept generation process the team brainstormed concepts together and separately using information gathered in research. The main flow measurement methods explored were ultrasonic, electromagnetic, coriolis force, x-ray radiology, and pressure difference. We used the theories behind these methods to develop possible solutions to our flow meter design. Basic sketches and descriptions of the concepts that were generated are located in the Appendix.

## Concept Evaluation

After creating a pros and cons list for each of the flow meters, engineering judgment was used to select five flow meters to be compared more closely in a screening matrix. The screening matrix used criteria based on the functional specifications of the project. The matrix can be seen in Table 1.

**Table 1. Flow meter screening matrix.**

Selection Criteria	Electromagnetic	Ultrasonic	Coriolis (Reference)	Venturi	X-Ray
Cost	0	0	0	+	--
Accuracy	0	+	0	0	-
Temperature range	0	-	0	-	+
Flow Media	-	-	0	0	-
Corrosion/Chemical Reaction	+	+	0	-	+
Thermal/Electrical Insulation	0	-	0	-	+
Signal/amplification required	0	0	0	0	-
Pipe Connections	+	+	0	-	+
Cooling Req.	0	0	0	0	+
Size	+	+	0	+	--
<b>Total Score</b>					
	2	1	0	-2	-2
<b>Rank</b>					
	1	2	3	4	4
<b>Continue?</b>					
	Yes	Yes	No	No	No

The screening matrix allowed the five meters to be ranked according to compliance with the selection criteria. The meters were all compared to the coriolis flow meter, which was chosen as the reference. After completing this analysis, the electromagnetic and the ultrasonic flow meters were chosen for further comparison.

To determine which would be the best of these two meters, a scoring matrix with weighted criteria was used. The scoring matrix can be found in Table 2.

**Table 2. Flow meter scoring matrix.**

Selection Criteria	Weight	Electromagnetic Meter		Ultrasonic Meter	
		Scoring	Weighted score	Scoring	Weighted score
Cost	5%	2	0.1	2	0.1
Accuracy	10%	2	0.2	3	0.3
Temperature range	25%	2	0.5	1	0.25
Flow Media	20%	1	0.2	1	0.2
Corrosion/Chemical Reaction	10%	3	0.3	3	0.3
Thermal/Electrical Insulation	10%	2	0.2	1	0.1
Signal/amplification required	5%	2	0.1	2	0.1
Pipe Connections	5%	3	0.15	3	0.15
Cooling Req.	5%	2	0.1	2	0.1
Size	5%	3	0.15	3	0.15
Total Score		2.00		1.75	
Rank		1		2	
Continue?		Yes		No	

The electromagnetic flow meter scored better than the ultrasonic meter because of its larger temperature range, lower cost, and ease with which it can be thermally insulated. Due to the close scores, however, the team voted to make the final decision, and the electromagnetic flow meter was selected for development.

## *Selected Concept Explanation*

The electromagnetic flow meter concept that was selected is based on Faraday's Law for conductive electromagnetic force. A schematic of how the concept works is shown in Figure 2.

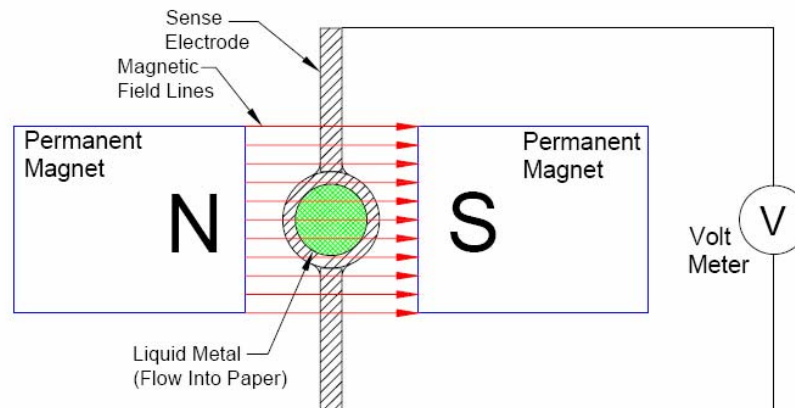

**Figure 2. Schematic of basic concepts. [ [www.creativeengineers.com](http://www.creativeengineers.com) ]**

The two permanent magnets create a magnetic field across the tube. Two electrodes are attached to the sides of the pipe. When a liquid metal passes through the magnetic field into the page, a voltage difference is generated across the electrodes that can be measured and calibrated.

## *Analysis and Proof-of-Concept Hardware*

The purpose of the first proof-of-concept hardware was to verify that a substantial voltage can be measured using conductive electromagnetism. We developed the idea for this concept by observing the flow of liquid metal through an existing electromagnetic

pump prototype composed of five stages (see Figure 3). After running tests with the electromagnetic pump to generate a constant state of flow, we anticipated that measurements could be taken from the electrodes of the pump to obtain a voltage reading as the liquid metal passed through the pump. The electrodes of one stage of the five-stage pump were wired to a voltmeter to gather these measurements. Then, the five-stage pump was filled with gallium to half of its capacity, and the liquid metal was passed through the pump from end to end by changing the angle of the pump.

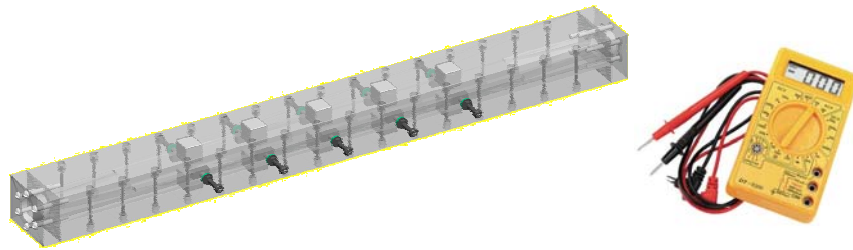

**Figure 3. The five-stage pump used to measure the flow passing through the magnetic field of the permanent magnets.**

This movement past the electrodes generated readings of approximately  $\pm 30$  millivolts on the voltmeter that was connected to the electrodes. This proved that a flow meter based on conductive electromagnetism would be feasible.

The next proof-of-concept hardware was developed to analyze what influence using a conductive steel pipe has on the ability to measure a voltage. The main concern was that there might be a short across the pipe that would inhibit a substantial voltage difference from being created. Figure 4 shows a photograph of the hardware that was developed using a simple schematic obtained from an electromagnetic flow meter manufacturer (<http://www.creativeengineers.com/>).

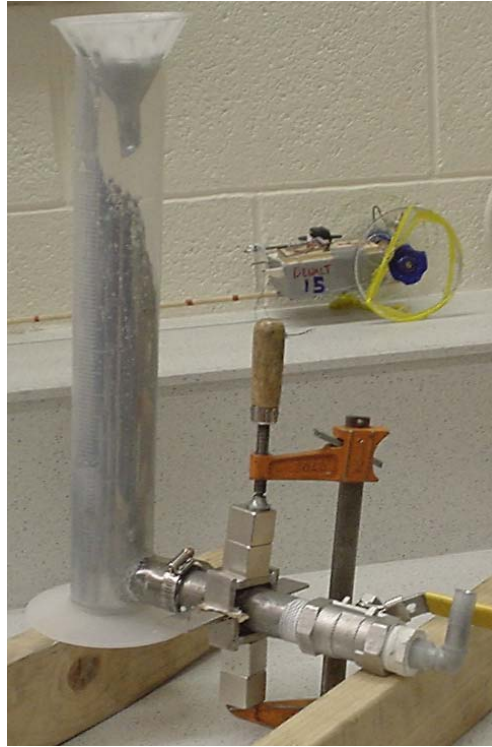

**Figure 4. Prototype built to test if a conductive pipe would create any problems.**

As seen in Figure 4, a graduated cylinder was used to create a flow through the flow meter, and the resulting outflow was captured in a beaker. A voltmeter was then attached to the electrodes welded to the pipe.

An analytical model was designed to predict the magnitude of the signal voltage to be obtained from this prototype. The governing equation for signal voltage ( $e_s$ ) is defined in Lorenz's Law (Equation 1):

$$e_s = kDB_f\overline{V}_f \quad (1)$$

“k” is a constant of proportionality, D is the magnetic gap,  $B_f$  is the magnetic flux density, and  $\overline{V}_f$  is the average flow velocity. In order to obtain an analytical model for the predicted output voltage, we solved this equation using approximate and assumed



values from our prototype as shown in Table 3. “k” was set arbitrarily at unity, “D” was dependent on setup,  $B_f$  was given by the permanent magnets used, and  $\overline{V}_f$  was an approximated assumption based on expected rates of flow. With these values, our predicted signal voltage was equal to 3.3mV.

**Table 3: Analytical Model Assumptions**

Variable	Value Assumed
k	1
D	1.5 in
$B_f$	0.18 T
$\overline{V}_f$	0.5 m/s

Both gallium and saltwater were passed through the meter to test the voltage generated between the electrodes. No signal was noted on the voltmeter in either case. This confirmed that either the voltage was shorted out across the conductive pipe or that the induced voltage was too low to be measured.

Current efforts are being focused on understanding and solving this problem. One idea is to use a non-conductive plastic or ceramic pipe and insert the electrodes through the pipe. Another proposed solution is to use powerful electromagnets instead of fixed magnets, so that it does not matter if some of the signal shorts across the pipe. A part of the team is also in contact with various experts to refine our understanding and design.

## Appendix J1

The following sketches show the various concepts generated.

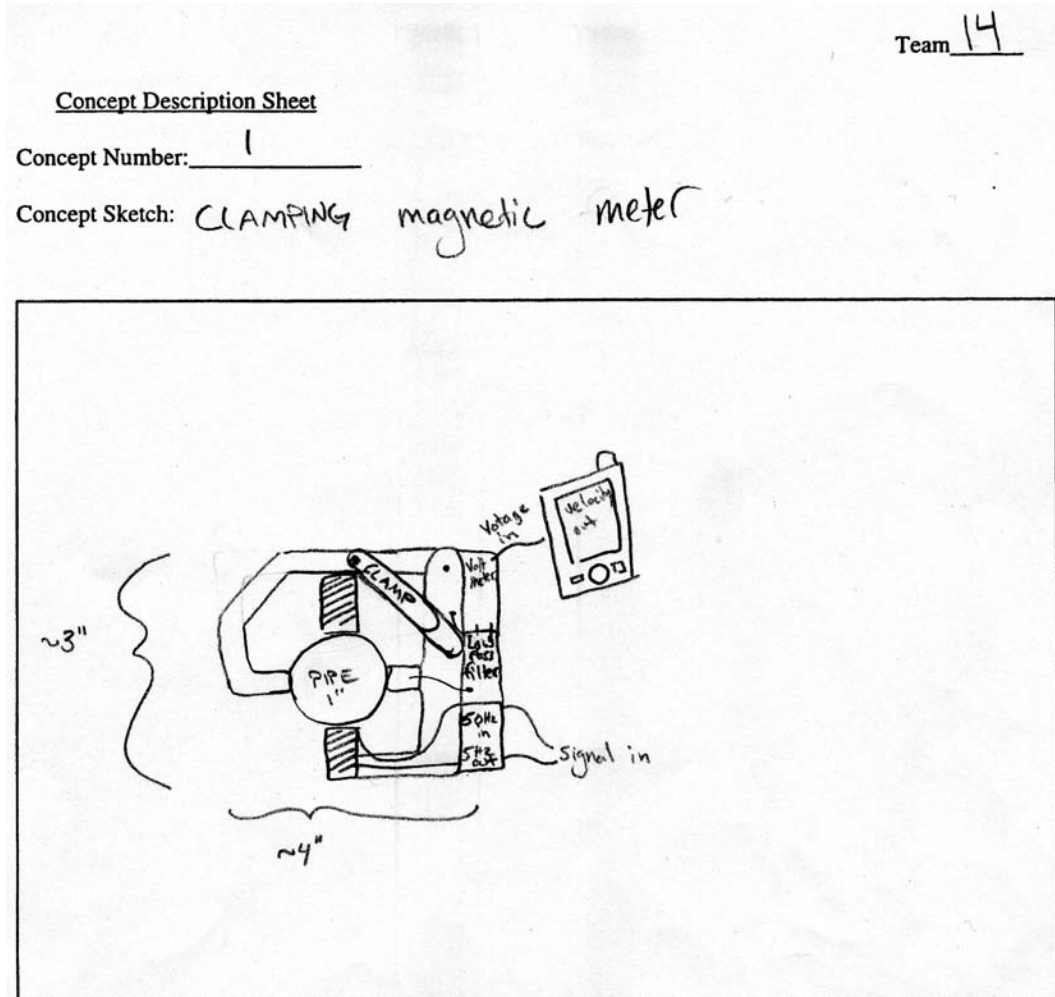

- Concept Description:
- opens wide enough to go easily over pipe
  - clamping mechanism to create intimate contact
  - Frequency modifier to create low frequency magnetic field
  - Low Pass Filter to remove "noise"
  - Voltmeter with output to PDA
  - PDA converts output voltage to average velocity

Concept Description Sheet

Concept Number: 2

Concept Sketch: ULTRA SONIC COOLING SYSTEM

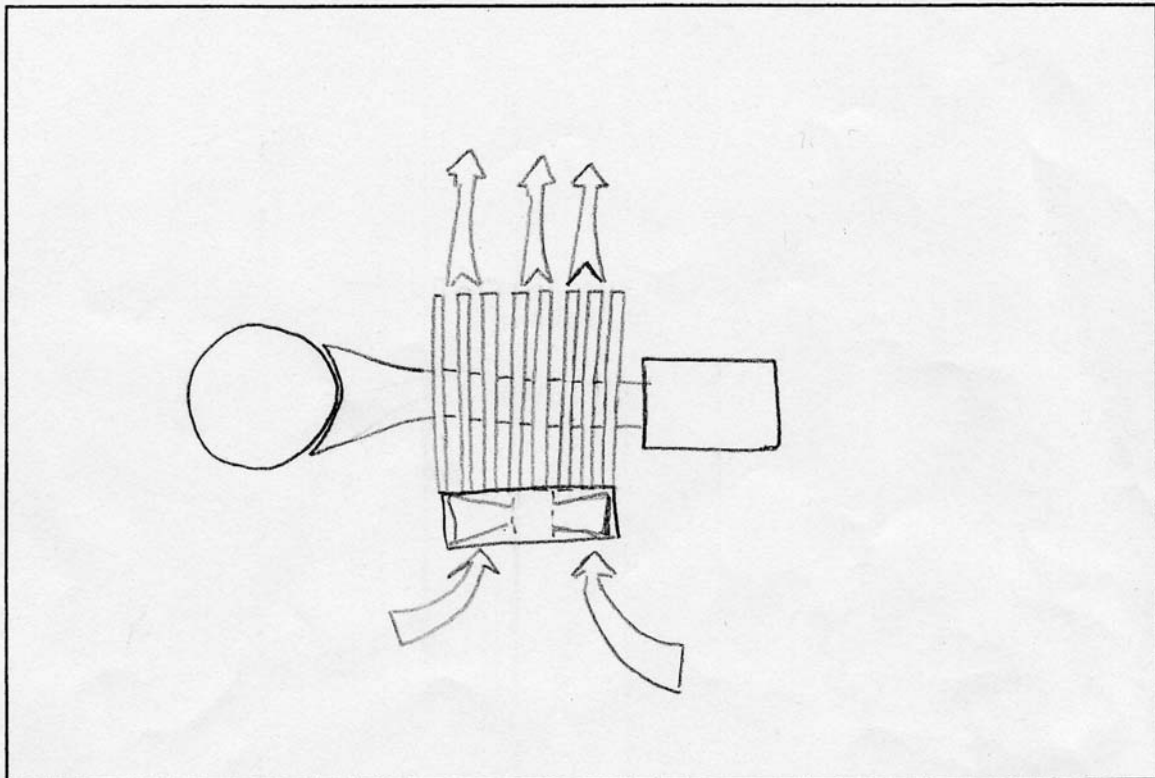

Concept Description:

- ACTIVE Air Cooling to maintain safe operating temperature for ultra sonic meter
- solid metal core to transfer Ultra Sonic signal the pipe

Concept Description Sheet

Concept Number: 3

Concept Sketch: Heat transfer flow meter

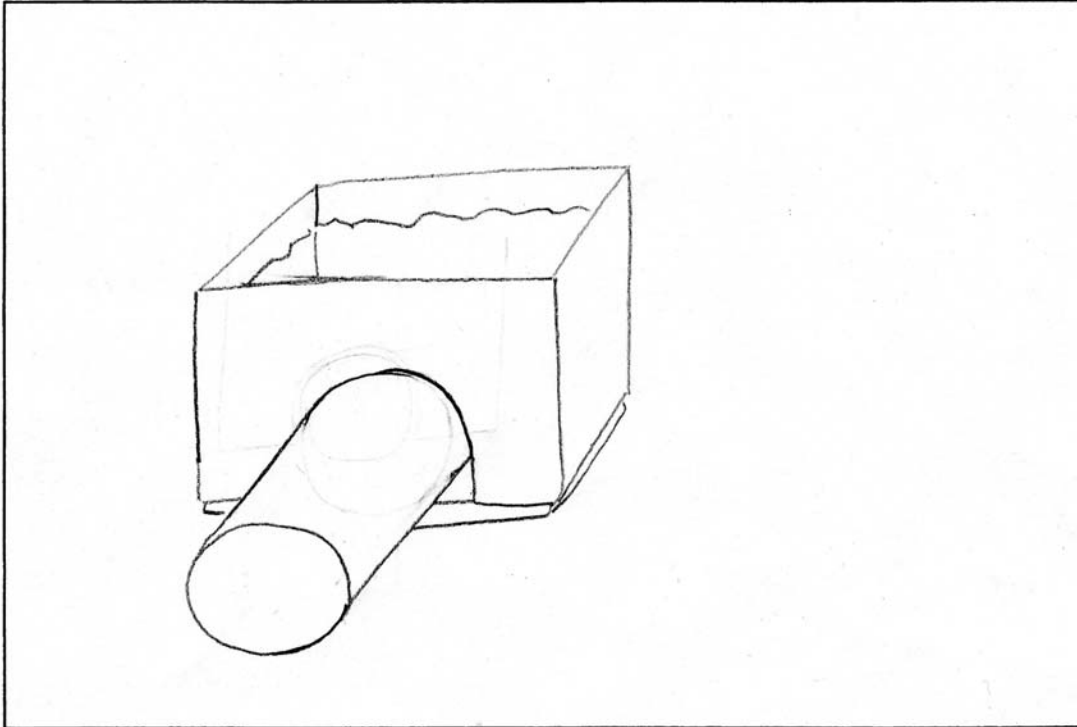

Concept Description:

- Clamp on a pot of water
- Flow rate determined by the time it takes for the water to boil.

Concept Description Sheet

Concept Number: 4

Concept Sketch: Water jacket for ultrasonic meter

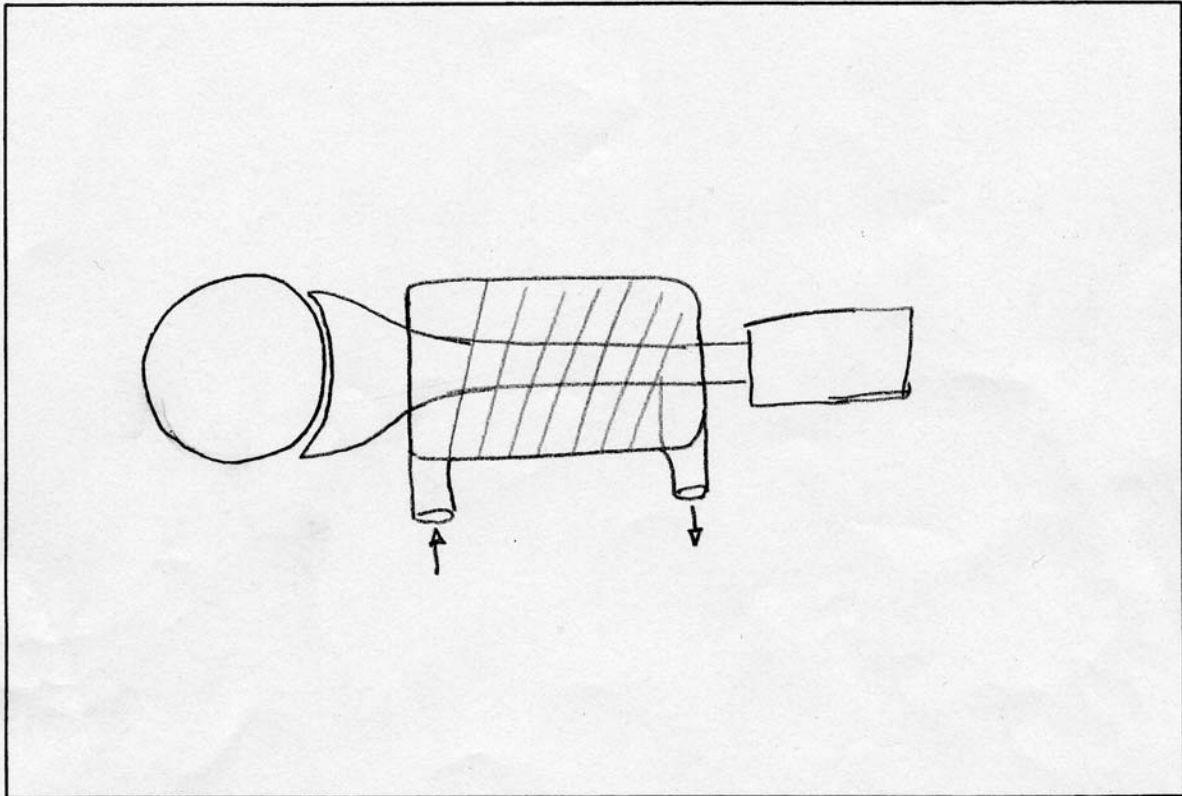

Concept Description: Water jacket circulates water to cool probe

Concept Description Sheet

Concept Number: \_\_\_\_\_

Concept Sketch: Heat transfer/Buoyancy driven Meter with Fins

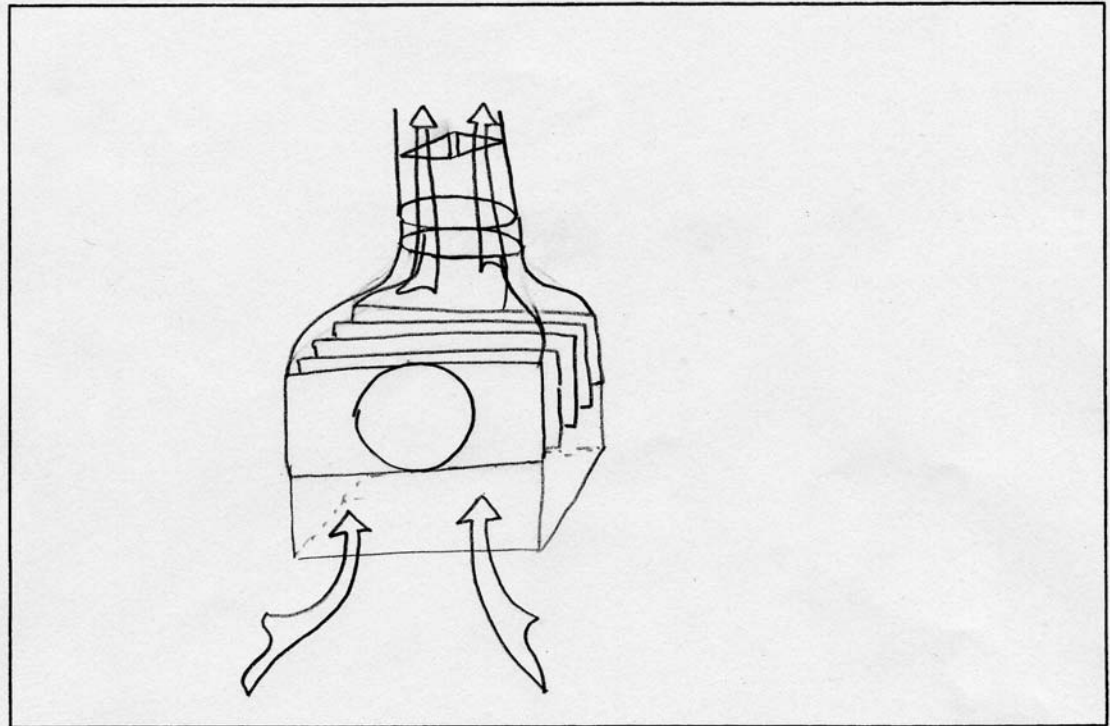

Concept Description: Invasive flow meter measures buoyancy driven flow, which corresponds to the velocity of the pipe flow. Fins added to increase the flow tempera

# Appendix K Design Proposal Report

December 8, 2005

Lockheed Martin-NY  
Liaison: Doug Milone

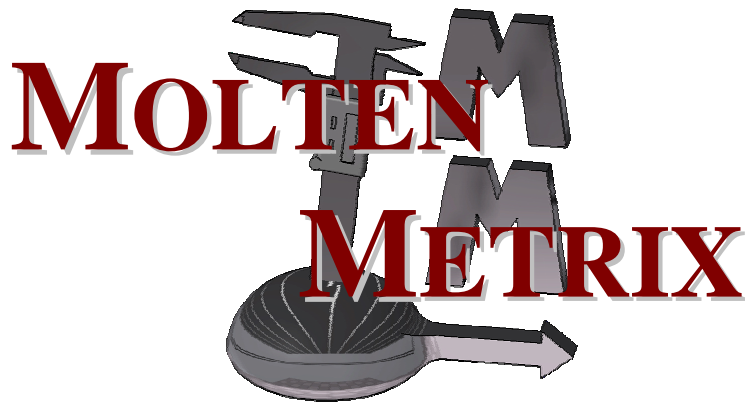

**Group #14**

Cameron Andersen · Summer Hoogendoorn · Benjamin Hudson  
Joseph Prince · Kendall Teichert · Jonathan Wood

**Capstone Program  
College of Engineering and Technology  
Brigham Young University**

Coach Approval: \_\_\_\_\_

## TABLE OF CONTENTS

Executive Summary	K-51
Introduction	K-52
Preliminary Design	K-52
Concept Justification Analysis	K-53
Analytical Flow Meter Model	K-53
Analytical Pump Model	K-55
Concept Justification Hardware and Experimentation	K-56
Design Questions	K-60
Test Loop	K-60
Calibration	K-60
Upgrading	K-60
Economic Analysis	K-60



## *Executive Summary*

The purpose of this project is to develop a flow meter for Lockheed Martin that measures the flow rate of molten metal in conduit. Key functional specifications for this project include  $\pm 5\%$  accuracy,  $300^{\circ}\text{C}$  operating temperature,  $800^{\circ}\text{C}$  survivability temperature, non-intrusive operation, 10 hour continuous run time, and 100 hour instrument life. Various concepts for measuring liquid metal flow have been examined and evaluated. These concepts and methods include: x-ray radiology, electromagnetism, ultrasonic shift, Coriolis force, and Venturi pressure difference. The conductive electromagnetic flow meter proved superior to the other concepts and was selected for this project.

After significant prototyping and analysis efforts, a preliminary design has been developed. This design includes an electrically non-conductive pipe with electrical taps. Output will be measured using the voltage difference caused by the motional EMF principal, which is directly dependent on velocity.

A detailed report of past analysis and hardware prototyping has been made. Several design questions have been addressed, including up-scaling procedures and setup for test loop for verification of concept and calibration. A financial analysis of the design predicts a savings of approximately \$10,000 after the development of two meters. A schedule outlining the project has also been developed to ensure we complete the required tasks in a timely manner.

It is clear that significant progress has been made towards successful project completion. Increased team understanding of the governing physical principles and improved team processes will ensure realization of our objectives.

## *Introduction*

Measuring the flow of liquid metal presents serious challenges. Current flow meters use ultrasonic, electromagnetic, and other technologies to measure flow, but the majority of these cannot operate at high temperatures. Furthermore, the high temperature, density, and surface tension of most liquid metals make containment a serious concern, both for safety and functionality. Despite the fact that the exact implications and applications of this technology are proprietary to the company, the development of a flow meter that can operate accurately at extremely high temperatures without the leakage will be a great asset to Lockheed Martin.

This project is to develop a flow meter that can operate at these elevated temperatures. Research has been done to explore the different types of technologies available. With this background a concept has been selected. This concept is based on electromagnetic principles. Initial testing of this concept has been completed with positive results. Theoretical and analytical justification has also been developed. This concept is here presented for proposal.

## *Preliminary Design*

The selection of electromagnetic technology for the flow meter design focused the scope of our preliminary design to a consolidated number of possibilities. Electromagnetic flow measurement technology is governed by an application of Faraday's Law called Motional EMF. This law states that a conductor, such as liquid metal, moving through a magnetic field will generate a voltage difference related to the velocity of the conductor (refer to Concept Justification Analysis for further explanation).

Several prototypes and analyses were performed prior to selection of the current design (see Concept Justification and Hardware for further explanation). The proposed flow meter design shown in Figure 1 consists of a section of nonconductive plastic piping with external permanent magnets and electrodes mounted on perpendicular axes on the sidewall of the piping. The electrodes penetrate the sidewall and maintain intimate contact with the flow medium (refer to Appendix 2 for detailed drawings of the proposed design).

This design is the result of a great deal of research and experimentation, but is yet incomprehensive and limited in several ways. First, the plastic piping is incapable of functioning at 300 to 800°C, which is the final temperature range specified. Future designs will require a pipe that is electrically nonconductive and capable of surviving these elevated temperatures. The most promising solution is currently a ceramic pipe.

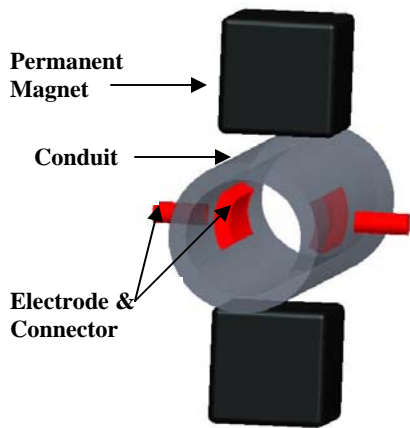

**Figure 1:** Current Flow Meter Design (left) and Prototype (right)

A second concern is that the plastic piping may leak fluid along the penetrating electrodes. Investigation is currently underway regarding the restraint of this possible leakage in both the plastic and ceramic designs. In the plastic design, the use of significant clamping force, washers and Teflon tape is expected to provide effective sealing. In the ceramic design, the electrodes will likely be sintered directly into the sidewall of the ceramic. Because the electrode is composed of stainless steel, which has greater thermal expansion than the ceramic, it is expected that such a press-fit seal will tighten at higher temperatures, provided the stresses remain within the strength of the ceramic.

Another concern deals with possible signal drift associated with the use of permanent magnets as the source of magnetic flux. The use of electromagnets with pulsed excitation voltage to provide magnetic flux would be a likely solution to this problem. The pulsed nature of the excitation will allow for bias compensation. If signal drift occurs, use of electromagnets will be implemented in the proposed design.

A final concern is the small magnitude of the output voltage generated in the flow sensor. The voltage output of the one inch inner diameter flow meter operating with flow speeds of three to five meters per second is expected to be less than 100 micro volts. As demonstrated by the developed hardware, the implementation of an amplifier into the data acquisition system converts this small voltage to easily readable levels.

## *Concept Justification Analysis*

### **Analytical Flow Meter Model**

As described above, the theory of electromagnetic flow measurement is derived from an application of Faraday's Law called Motional EMF. The governing equation of Motional EMF is given in vector Equation 1.

(1)

$$\vec{\varepsilon} = l\vec{B} \times \vec{v}$$

$\varepsilon$  = voltage generated

$B$  = magnetic field strength

$l$  = distance between electrodes

$v$  = velocity of the conductor (fluid)

Figure 2 shows a schematic used in the generation of this analytical model.

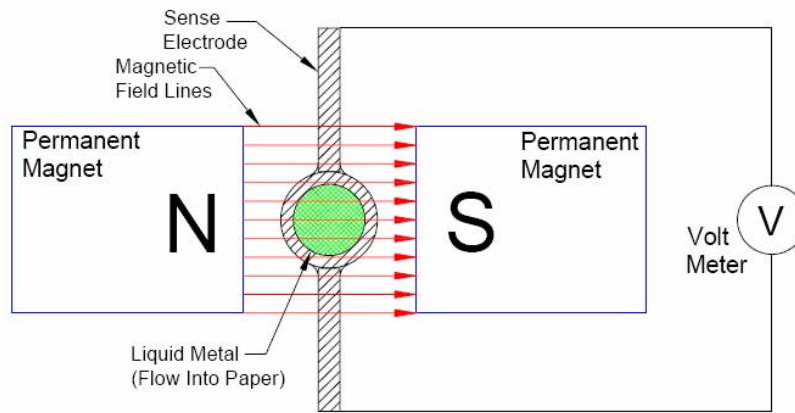

**Figure 2:** Initial Design Schematic. Source: <http://www.creativeengineers.com>

In this specific application, because the magnetic field and the fluid flow are orthogonal to one another, this vector equation simplifies to scalar Equation 2.

$$\varepsilon = lBvk \tag{2}$$

$k$  = constant determined by calibration

Equation 2 serves as the current analytical model of the flow meter. Using the values given in Table 1, a predicted output voltage of 2.75mV was obtained.

**Table 1: Analytical Flow Meter Model Values**

Variable	Value	Justification
$k$	1	assumed
$l$	1.5 in	measured
$B$	0.15 T	measured
$v$	0.5 m/s	assumed
$\varepsilon$	<b>2.75 mV</b>	calculated

Unfortunately, the assumption of the value for  $k$  proved to be incorrect and the predicted output voltage was much too high. Upon further experimentation, it became clear that  $k$  in this application is approximately equal to 0.001, and that expected voltage output is to be in the microvolt range. This experimentation is described in more detail in Concept Justification Hardware and Analysis.

### *Analytical Pump Model*

In the actual experimentation performed with this prototype, a simple electromagnetic pump was used to create the required flow. Electromagnetic pumps operate by forcing an electrical current through a conductive fluid in the presence of a magnetic field. The principle governing this reaction is called the Lorentz Force Law and is demonstrated in vector Equation 3.

$$\vec{F} = i\vec{l} \times \vec{B} \quad (3)$$

$F$  = magnetic force exerted on fluid

$i$  = electrical current in fluid

$l$  = distance between electrodes transmitting current through fluid

$B$  = magnetic field strength

As before, this equation simplifies in this application because of the orthogonal topology inherent in the pump design. The simplified version is shown in scalar Equation 4.

$$F = ilB \quad (4)$$

Table 2 shows the values used in the analysis of the electromagnetic pump. These values yield a force of 0.088 N.

**Table 2: Analytical Pump Model Values**

<b>Variable</b>	<b>Value</b>	<b>Justification</b>
$i$	15 A	measured
$l$	1.5 in	measured
$B$	0.15 T	measured
$F$	<b>.088 N</b>	calculated

Current experimentation is being performed with liquid gallium, which has a convenient melting temperature just above room temperature (by running tests with Gallium it is possible to achieve similar properties to those of other molten metals without the elevated temperatures). Gallium has a density of  $6100 \text{ kg/m}^3$  at its melting temperature, and approximately 0.15 kg of gallium would experience the force simultaneously based on the geometry of the pump section. By Newton's first law, when experiencing a force of 0.088 N, the gallium would be accelerated at approximately  $0.02 \text{ m/s}^2$ . After experiencing viscous drag and other losses, this acceleration can be assumed to produce an appropriate velocity.

### *Concept Justification Hardware and Experimentation*

We developed the idea for this concept by observing the flow of liquid metal through the pre-existing electromagnetic five-stage pump prototype shown in Figure 3. The body of the pump is constructed of non-conductive Plexiglas. At each pump stage, two stainless steel electrodes are mounted inside, on opposite sides, and two permanent magnets are mounted above and below the channel. This pump was developed by a previous Capstone team to generate a steady rate of flow using liquid metals. This five stage pump has been a major part of our initial concept experimentation.

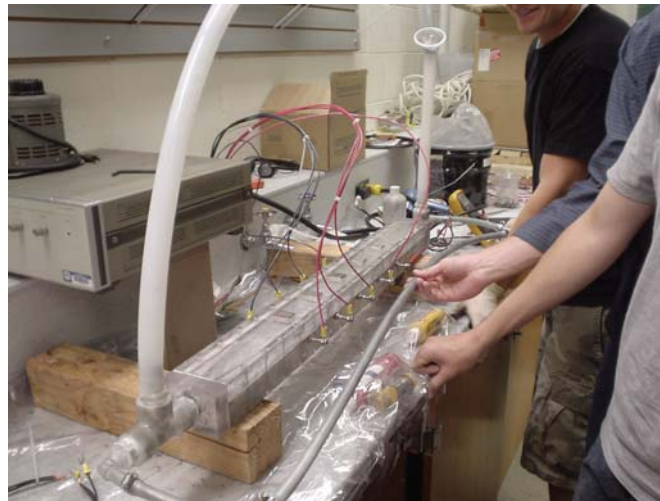
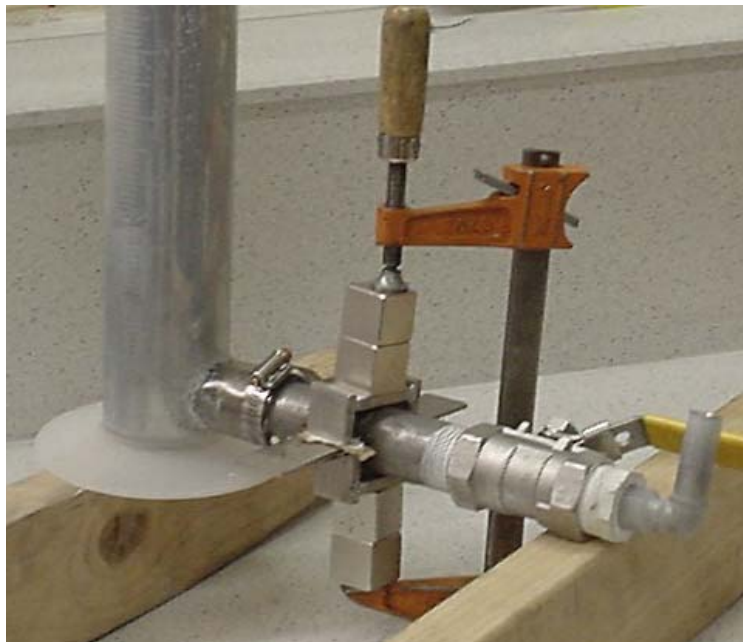

**Figure 3.** The five-stage pump used to measure the flow passing through the magnetic field of the permanent magnets.

The five-stage pump operates by the same principles detailed earlier. It was anticipated that measurements could be taken from the electrodes of the pump to obtain a voltage reading as the liquid metal passed through the pump. In an early experiment, the electrodes of one stage of the five-stage pump were wired to a voltmeter to measure the generated voltage. Then, the five-stage pump was filled with gallium to half of its capacity, and the liquid metal was passed through the pump from end to end by changing the angle of the pump.

This flow across the electrodes generated readings of approximately  $\pm 30$  millivolts on the voltmeter connected to the electrodes. It is assumed that the voltages measured here were much higher than analytically predicted because of the different geometry and flow rates of the five-stage pump. This experiment indicated that the development of a flow meter based on conductive electromagnetism would be feasible. However, operation of the five-stage pump and flow meter in a static head test, as shown in Figure 3 did not produce a measurable signal.

The next proof-of-concept hardware was developed to analyze what influence using a conductive steel pipe would have on voltage measurements. This prototype was constructed by welding electrodes onto the external side wall of a 1 inch inner diameter stainless steel pipe section. Permanent magnets were also mounted externally onto the pipe. The insertion of the prototype into the lower portion of a graduated cylinder allowed for gravity-driven liquid metal flow through the flow meter. The resulting outflow was captured in a beaker. A voltmeter was then attached to the electrodes welded to the pipe. Figure 4 shows this test set-up.



**Figure 4:** Initial Design Prototype

In separate tests, saltwater and gallium were passed through the flow meter to test the voltage generated between the electrodes. No signal was noted on the voltmeter in either case. This confirmed that either the voltage had been shorted across the conductive pipe or that the induced voltage was too low to be measured.

After this experimentation, a very simple design was tested. This design included a small circular trough milled from an acrylic base. The trough included two stations, each with



electrodes and permanent magnets: one functioned as the pump and one functioned as a meter. In this simple manner, flow was both generated and measured using the principle of conductive electromagnetism (see Figure 5). This simple arrangement provided visible confirmation of flow in the channel.



**Figure 5:** Two Station Acrylic Test Loop

After failing to record measurable voltage when testing with salt water, we modified this same setup using principles of inductive measurement. We wrapped wire coils around each permanent magnet and attached a voltmeter to the coils to gather readings (Figure 6).

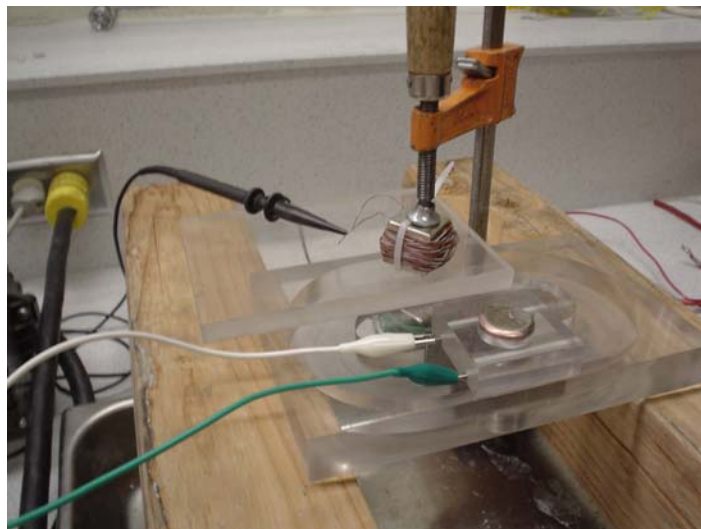
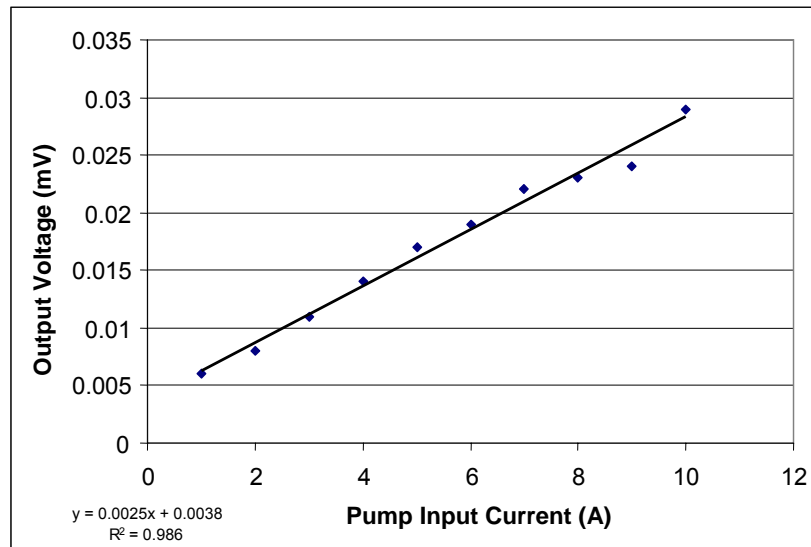

**Figure 6:** Inductive Measurement Experimentation



It was anticipated that this technique would induce eddy currents in the flow of the fluid, changing the magnetic field and corresponding voltage reading. This method proved to be ineffective with both saltwater and liquid gallium, as we discovered that there were no substantial readings generated in the process.

Through further analysis and analytical modeling we assumed that the use of a more sensitive voltmeter was required to measure the flow signal. The previous tests each employed a millivolt meter. After acquiring a microvolt meter, we repeated the experiment with gallium in the acrylic test loop and recorded steady voltages related to the flow rate. Figure 7 shows output voltage versus current input to the pump. The pump current input, as described earlier, can be directly related to the flow rate of the fluid. As shown in the figure, the output voltage is linearly related to the pump current with a correlation coefficient value of  $R^2 = 0.986$ .



**Figure 7:** Output Flow Meter Voltage in Focused Physical Prototype

Our most recent prototype design is composed of flexible low density PVC piping with two stainless steel electrodes positioned inside the pipe. A rod connected to each electrode penetrates through the pipe to allow for voltage measurements. Two permanent magnets have also been positioned in a perpendicular orientation to the electrodes. Although testing has not yet been performed with this prototype, it is expected that it is a reasonable representation of the final design.

The extensive prototyping and experimentation performed have greatly increased the team's understanding and confidence. Each model led to adjustments which have led to the current design. As explained earlier, there remain significant limitations to the current design, but the team is confident that the modifications necessary can be implemented to overcome any limitations.

## *Design Questions*

### **Test Loop**

*What materials will we use in our final test loop?*

Our test loop must be able to withstand high temperatures, a maximum of 800 C. At least a small section (the test section) needs to be nonconductive. No leakage is also a requirement, thus the thermal coefficient of expansion of the materials is also a concern. We are considering building our test loop of stainless steel with the test section consisting of ceramic. Before we purchase the materials we must do further research and analysis to ensure the stainless steel will not cause the ceramic to crack.

### **Calibration**

*How will we calibrate our flow meter?*

Our meter must be accurate within  $\pm 5\%$ . We need a fairly precise method of calibration. Our future plans for calibration include using a gear pump that has an output reading. Gear pumps are positive displacement. The flow rate generated is linear with RPM. We feel this will be an efficient method as the pump will create flow of known flow rate, determined by RPM measurement, thus limiting our instrumentation. We plan to purchase the gear pump before the semester's end.

### **Upgrading**

*What modifications must be made within our current concept to meet the high temperature specifications?*

To start, we are not designing our initial flow meter for high temperature applications. We are using materials such as PVC that cannot withstand high temperatures. However, we must consider the high temperature requirements in the near future. Our plans for modification include designing and creating a cooling jacket or heat sink for our meter, which will separate the instrumentation from the extreme heat. We also plan to use ceramic or stainless steel piping, which are durable in high temperature applications.

*How will we test at high temperatures?*

We must test our meter at temperatures as high as 800 C. Our large electromagnetic pump will not be able to sustain high temperatures due to the wiring. We have yet to come up with a solution to this problem. Our ideas for high temperature testing include: locating a foundry that would be willing to allow us to do testing in their facility, or using a furnace to heat our material, while keeping the electrical components outside the furnace.

### **Economic Analysis**

To analyze the economics of the liquid metal flow meter, we have taken into consideration the cost of its design and production. The meter will not be sold commercially, but will be implemented internally at Lockheed-Martin for research and

development purposes. Thus, no analysis of sales revenue and other related figures will be performed. However, we must consider the amount of time it will take for the sponsor to recover funds invested in our project. Research and development is an instrumental element of Lockheed-Martin's mission to maintain their position as a technological leader in their industry. Lockheed-Martin has several divisions focused on research and development. This flow meter will be used for experimentation purposes to further the research efforts in one of these divisions.

Lockheed-Martin will recover their incurred costs over the useful life of the flow meter. Lockheed-Martin has put forth \$18,500 thus far towards the completion of this flow meter. Molten Metrix has been allotted \$1,200 of that sum for hardware. Current expenditures have remained within the boundaries of this budget. We have not built extensive hardware, and plan to incur most of our cost in the coming months as we turn our research and analysis into working models.

We are confident that our flow meter will provide economic benefit to Lockheed Martin as it is implemented in their research operations. The only flow meter that has been found on the market that meets the required specifications is through Creative Engineers. This flow meter was quoted at \$18,000. Although this is less than Lockheed Martin has already placed into this project, the main benefit for this project is to provide the technology that can be implemented into several different areas. The actual manufacturing of each additional meter is expected to cost \$1000 or less. Thus after only implementing two meters (including the original product delivered by capstone) Lockheed Martin will have saved over \$10,000.

# Appendix L Design Analysis and Experimentation Report

February 17, 2006

Lockheed Martin-NY  
Liaison: Doug Milone

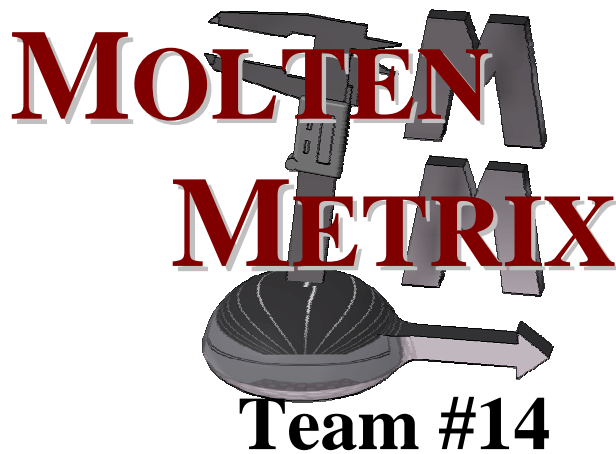

Cameron Andersen · Summer Hoogendoorn · Benjamin Hudson  
Joseph Prince · Kendall Teichert · Jonathan Wood  
Dr. Ken Chase

Capstone Program  
College of Engineering and Technology  
Brigham Young University

Coach Approval: \_\_\_\_\_

## TABLE OF CONTENTS

Analytical Flow Meter Model.....	L-72
Model of Interference Fits.....	L-73
Heat Transfer Model for Test Loop .....	L-75
Prototype Hardware.....	L-77

## *Executive Summary*

The purpose of this project is to develop a flow meter for Lockheed Martin Corporation that measures the flow rate of molten metal in a conduit. Customer needs for this product center around accurate and reliable measurements in high temperature applications. Many prospective technologies require intimate or visual contact with the flow itself, but due to the properties of molten metal flow, leakage is a serious concern. This necessitates the use of non-intrusive metering technology.

In order to develop the best meter possible for a high temperature operating environment, key functional specifications have been determined as follows:

Operating temperature of 300° C

Survivability temperature of 800° C

Accurate measurements within  $\pm 5\%$

Non-intrusive

Compatible with different materials including: lead, lead bismuth, molten salt, and sodium potassium

Continuous operation life of 10 hours

Instrument life of 100 hours

Achieving these target specifications will ensure customer satisfaction and will enhance flow measurement technology in general.

After in-depth research, the conductive electromagnetic flow meter proved superior to the other concepts and was selected for this project. The team developed a preliminary prototype as discussed in the Prototype Hardware section of this report. After significant design and analysis efforts, a final design has been developed. This design includes an electrically non-conductive pipe with electrical taps, operating in a strong magnetic field, orthogonal to the flow. During this semester, we have focused our efforts to determine the details of this final design. The high temperature requirements and highly reactive material usage cause challenging concerns in material selection. This report outlines the steps taken to reach the advanced concept of the final design.

The output of the flow meter will be measured using the voltage difference caused by the motional EMF principal, which is directly dependent on flow velocity. This concept is further discussed within this analysis.

A detailed report of the analyses performed is included in this report. During our design efforts, analytical models have been essential. Performing mathematical analysis has reduced design iteration and has proven a reliable way to get important information quickly. At times, hands-on experimentation has been conducted to ensure, in physical terms, that the design is capable of performing. These analysis and experimentation efforts are outlined within the text of this report.

As the project nears completion, the team faces high temperature design issues. These issues are discussed along with other up-scaling procedures involved in the construction of a fluid circuit for verification of concept and calibration of the prototype.

The attached appendix provides detailed information on our design and analysis. A schedule outlining the project has also been developed to ensure we complete the required tasks in a timely manner.

It is clear that significant progress has been made and will continue towards successful project completion. Essentially, all critical parameters of the design have been well researched and a proposed solution is in place for each of those parameters. The next two months will be spent testing these solutions to ensure their accuracy. It is with much optimism that the team presents this report. We feel confident in our ability to succeed in completing this project.

## Introduction

Measuring the flow of liquid metal presents serious challenges. Current commercial flow meters use ultrasonic, electromagnetic, and other technologies to measure flow, but many complications are encountered at high temperatures. These include the safety and usability concerns of containment at high temperatures for most liquid metals. This has necessitated the development of a high temperature flow meter, capable of measuring flow of liquid metals.

This project has been to develop such a flow meter. This meter will operate continuously at 300° C. Accuracy of +/- 5% will be obtained, along with a compatibility with various liquid metals and other materials. Other functional specifications include a survivability temperature of 800° C. The meter will have the ability to run continuously for 10 hours and have a 100 hour instrument life. Research has been carried out to explore the different technologies available, and a specific concept has been selected. Initial testing of this concept at room temperature has been completed with positive results. Theoretical and analytical justification has also been developed.



**Figure 1. Current Flow Meter Design**

The design for the flow meter incorporates electromagnetic technology. A ceramic section of pipe has been designed to provide a high temperature-compatible solution for the thermal environment. Ceramic was also chosen because of its low reactivity with most materials. This section will interface to the test flow loop using a Kovar™ (low thermal expansion metal) sleeve to eliminate cracking. Electrodes will be placed in the side wall of the ceramic pipe to measure the voltage difference in the moving

metal.

This design coupled with material selection, will meet the design specifications of temperature range and corrosion resistance, as well as eliminate concerns of thermal expansion. Analytical models have been developed to determine and justify several critical design specifications, such as: the interference fit between Macor™ and Kovar, as well as between Kovar and Stainless Steel; the losses to be incurred in the flow and thus



what output voltage can be expected; heat transfer capabilities needed to reach specified temperatures, and electrode size requirements. This report will provide legitimate justification for each element of the design that has been selected.

## Design Questions

*What materials will be used in our final test loop?*

The test loop must be able to withstand high temperatures, with a maximum temperature of 300°C. Corrosion is a severe challenge with molten metals at these high temperatures. Additionally, the flow meter section needs to be electrically resistant to ensure that the voltage generated by the flow will not be shorted. No leakage is also a requirement, thus the thermal coefficient of expansion of the materials is also a concern. With these specifications, in-depth research and analysis has been carried out to lead to a good match in material.

Over a foot of stainless steel piping was inherited from last year's electromagnetic pump project. Because of this availability and because of the desirable corrosion resistance and strength properties, the decision was made to use these supplies in our test loop.

The molten metal chosen for the test loop is gallium. It was chosen because it melts at a temperature just above room temperature, making it ideal for preliminary room temperature testing. However, gallium is reactive with most metals at room temperature and highly reactive at elevated temperatures. Stainless steel is one of the few metals with which gallium does not react appreciably at room temperature, and testing demonstrates that it is resistive to corrosion up to 300°C.

Because of the high electrical conductivity of stainless steel, another material was needed for the flow meter section. After a brainstorming session and a material reactivity study, it was decided that ceramic would be the most viable material for the flow meter. The flow meter would consist of a ceramic tube with diametrically-opposed electrical feedthroughs. Macor, a machinable ceramic, was selected for its desirable corrosion resistance, thermal expansion, and electrical resistance properties.

In designing an effective seal to connect a ceramic flow meter section to a stainless steel flow circuit, many options were considered. After consultation with academic and professional experts, a design was selected using a Kovar interface sleeve between the Macor and stainless steel (*see Appendix B for complete drawings*).

Material	CTE ( $\times 10^{-6}/^{\circ}\text{F}$ )
Stainless Steel	9.6
Kovar	2.85
Tungsten	2.4
915 Macor	5.2
M Glass Ceramic	5.2
960 Alumina	4.3
56L Graphite	3.1
902 Alumina Silicate	1.8

**Table 1. Coefficients of Thermal Expansion**

To ensure that Macor would meet the specifications, analysis was done to observe the difference in thermal expansion rates of Macor and Kovar (*see page 11 for analysis*). Table 1 and Figure 2 show some coefficients of thermal expansion for potential metals and ceramics. It was concluded from the Interference Fit analysis that these materials' rates of expansion were similar enough to provide confidence in the design.

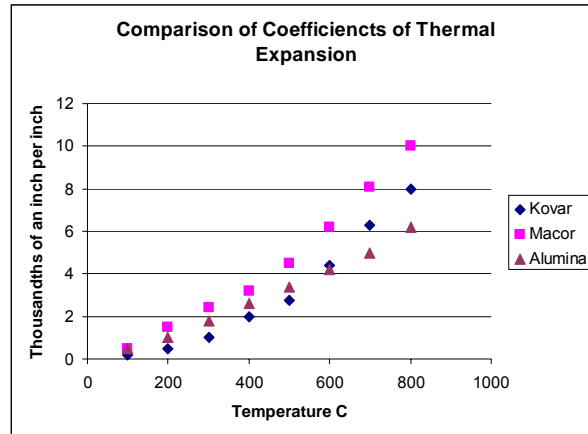

**Figure 2. Thermal Expansion Rate vs. Temperature**

Macor's rate of thermal expansion is slightly greater than that of Kovar. Considering this, Macor will be put into compression as the materials are heated. Ceramics can withstand substantial compression. Macor also has strong bonding capabilities. Macor is easily machined with the use of ordinary machine tools.

*How will we calibrate the flow meter?*

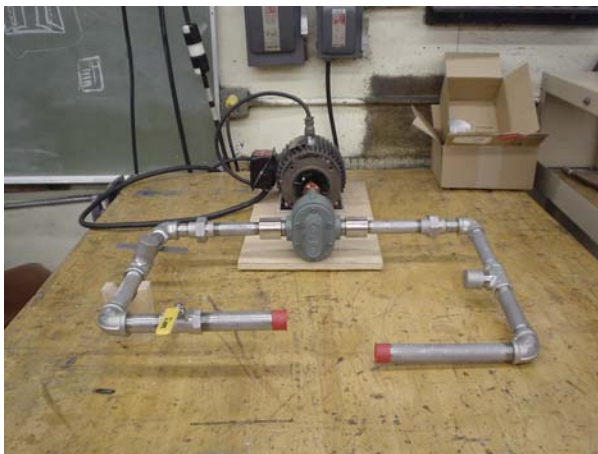

**Figure 3. Test Loop Setup**

The meter must be accurate within  $\pm 5\%$ . This will be accomplished using a precise method of calibration. We have developed the setup needed for the calibration of the flow meter, and are awaiting the completion of last year's electromagnetic pump to use in the final, high temperature testing.

As an interim method of generating flow we have selected a positive displacement gear pump, coupled with a 2 horsepower DC motor with a digital speed controller. Preliminary tests with water indicate that the flow rate generated is directly and

linearly related to the rotations of the motor. From our test results, we can measure the volume displacement per revolution, which will allow us to find the flow rate of the

Gallium. We feel this will be an efficient method, as the pump will create flow of known flow rate, determined by RPM measurement, thus limiting our instrumentation.

*What signal output will the meter have?*

In initial testing with permanent magnets and low flow rates, the output voltage was measurable in microvolts (*see Flow Meter model and testing*). With the use of an electromagnet and higher flow rates, the meter should increase the voltage up to 10 times.

A second concern is the issue of noise interfering with the signal output. Through research, it has been determined that using an electromagnet will greatly increase the signal-to-noise ratio and eliminate bias. Permanent magnets are steady-state, producing a DC signal subject to drift. The electromagnet is AC. It should be more stable. Permanent magnets are steady-state, producing a DC signal subject to drift. The electromagnet is AC and should be more stable. If testing shows otherwise, a filter can be used to distinguish the signal.

*What magnetic field source should be used?*

Thus far, permanent magnets with a high magnetic strength have been used in testing. As high temperature testing is conducted, the curie temperature of the permanent magnets may be reached or passed. Also, permanent magnets only offer a maximum magnetic strength of 0.2 Tesla.

These problems will be solved by using an electromagnet with a low resistance return path for the magnetic flow circuit. Most electromagnets on the market today can operate at temperatures up to 500 C. As the electromagnet will not be in direct contact with the actual flow loop, its environment temperature will not exceed 500 C. Electromagnets can offer up to ten times the magnetic strength of permanent magnets. These conditions justify the use of an electromagnet. The electromagnet designed to be used as the driving force in electromagnetic pump at high temperatures is shown in Figure 4. Before the electromagnet will be used in that application, we will use it as an electromagnet to power our flow meter.

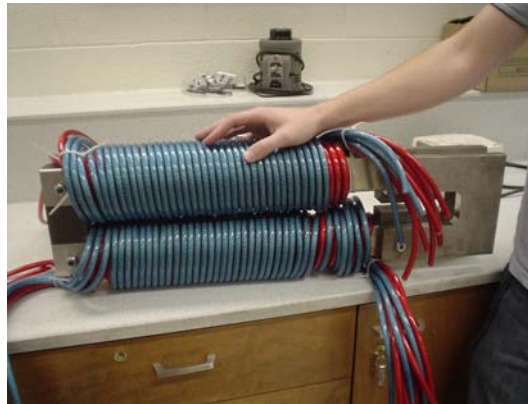

**Figure 4. Electromagnet**

*How will we heat our circuit to 300 C?*

A brainstorming session was held, the top ideas included: using Bunsen burners, a heat gun, blow-dryer, heat tape, barbeque or blow torch. Individual team members were assigned different methods to be explored. In the end heat tape was selected as our method of circuit heating. Analysis has been conducted to determine how much wattage is needed to heat the test circuit (*see Heat Transfer analysis*). The determined wattage needed is approximately 200 watts per meter of pipe length. The heat tape that has been purchased will be more than adequate to fulfill this requirement with a wattage of 328 watts per meter.

*What size must the electrodes be?*

Initially stainless steel plates measuring approximately ½ inch by 1 inch were used in testing as electrodes. The question arose recently in the design of the ceramic flow meter: Do we actually need plates? Will metal rods suffice? This is a considerable concern as design would be greatly simplified if rods could be used. A test was conducted to determine the difference in signal output when using a plate and a rod (*see Electrode analysis*). From this testing, it was concluded that the difference in voltage output is insignificant. Thus, the design was simplified to include stainless steel rods as electrodes.

*What size pump is needed to generate needed flow?*

The liquid metal must flow at three to five meters per second. To generate this flow at low temperatures, a positive displacement gear pump has been selected that can generate flow of at least 3 meters per second. To further analyze the possibilities of flow rate, an analysis of the flow circuit losses was conducted (*see Fluid analysis*).



**Figure 5. Positive Displacement Gear Pump**

## *Analysis and Experimentation*

### *Analytical Flow Meter Model*

In order to estimate what voltage will be read by the flow meter at different velocities, we used an equation derived from an application of Faraday's Law called Motional EMF. The governing equation of Motional EMF is given in vector Equation 1.

$$\vec{\varepsilon} = l \vec{B} \times \vec{v} \quad (1)$$

$\varepsilon$  = voltage generated

$B$  = magnetic field strength

$l$  = distance between electrodes

$v$  = velocity of the conductor (fluid)

In this specific application, because the magnetic field and the fluid flow are orthogonal to one another, this vector equation simplifies to scalar Equation 2.

$$\varepsilon = lBvk \quad (2)$$

$k$  = constant determined by calibration

Equation 2 serves as the current analytical model of the flow meter. Using the values given in Table 2, a predicted output voltage of 17mV was obtained.

<b>Variable</b>	<b>Value</b>	<b>Justification</b>
$k$	1	assumed
$l$	1.5 in	measured
$B$	0.15 T	measured
$v$	3 m/s	required
$\varepsilon$	<b>17 mV</b>	calculated

**Table 2. Analytical Flow Meter Model Values**

In the table above, the results assumed a  $k$  value of 1.0. After the ceramic flow meter has been built and tested, a more accurate  $k$  value can be determined experimentally. In proof of concept testing a value 3.2 mV was obtained, at low velocities. However, those tests were conducted using a slightly different geometry, and could not be used to predict the constant for the final flow meter.

### Model of Interference Fits

In order to answer the question of what type of materials should be used in interfacing between the ceramic pipe and the stainless steel pipe, it was very important to derive a model that could predict the stresses that would be induced through thermal expansion.

The model was created by analyzing interference fits between two concentric cylinders that begin with no interference at room temperature. Figure 6 shows a graph of the maximum stresses that would be expected because of thermal expansion while raising the temperature to 800°C.

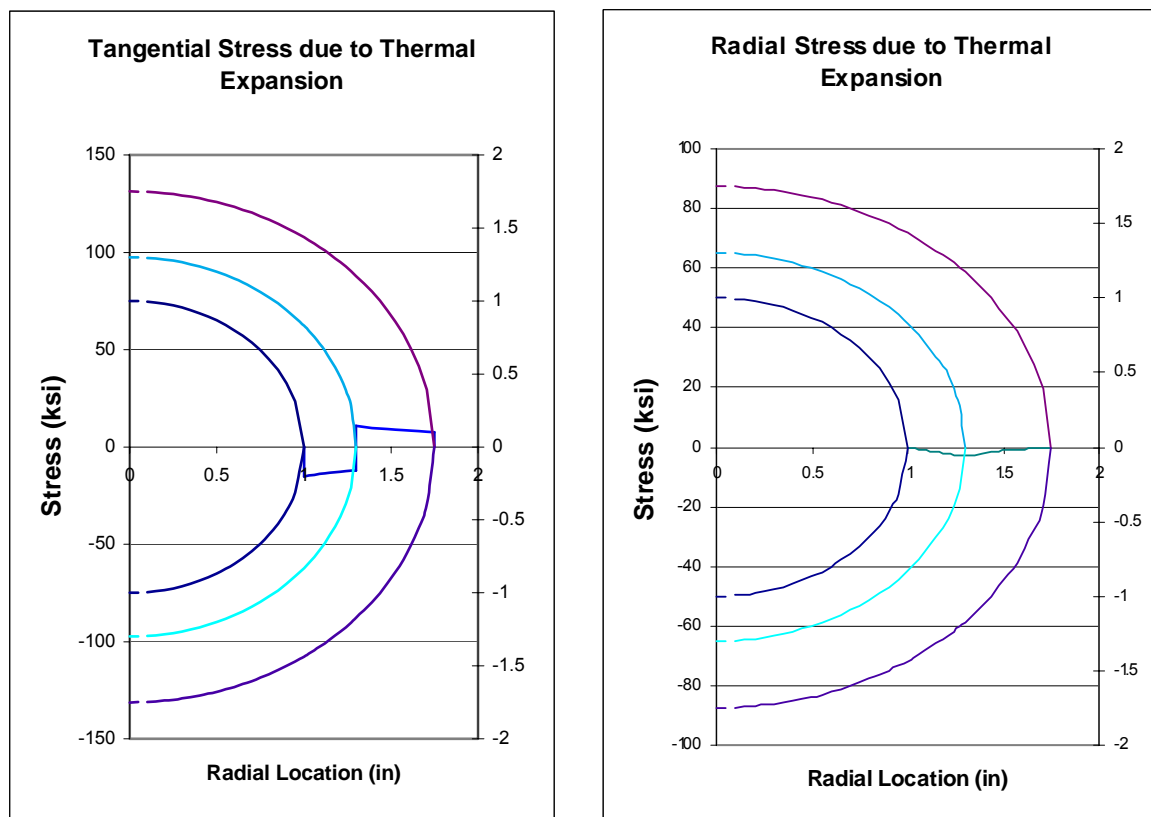

**Figure 6. Radial and Tangential Stress between Macor and Kovar**

It can be noted from Figure 6 that the maximum stress due to thermal expansion from room temperature to 800°C is much less than the compressive strength of Macor which is 50 ksi. A safety factor for the Macor was determined to be 3.3 (*see Appendix for complete model*).

### Fluid Model of Flow Losses

In determining what type of pump to purchase for the flow loop, it was important to know how much power would have to be delivered to overcome losses at the maximum flow rate of 31 gallons per minute. The mechanical energy equation was used to determine how much pump head would be required to maintain the flow rate at 3 m/s.

The required pump head was found to be 37 psi. This pressure was then multiplied by the area and the velocity of the flow to determine how much power would be required by the pump. The power requirements for the pump were determined to be 1 Hp (*see Appendix for complete model*).

#### *Experimentation to Determine the Necessity of Electrodes*

In order to determine if large plate electrodes were necessary, we first looked at the analytical model that was derived from Faraday's law for determining the voltage difference across an electromagnetic flow meter. It was not apparent from the model that large plate electrodes would be necessary. Because it was such an important design parameter that directly affected the manufacturing processes we chose, we decided that it would be valuable to run some tests using the racetrack prototype (*see Figure 7*) both with and without plate electrodes. The testing is shown below in Figure 7.

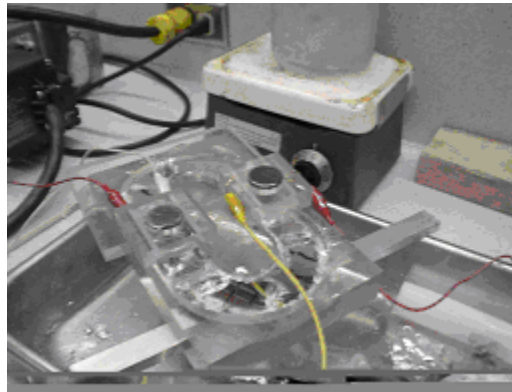

**Figure 7. Electrode Testing with Racetrack Prototype**

Figure 8 shows the test results.



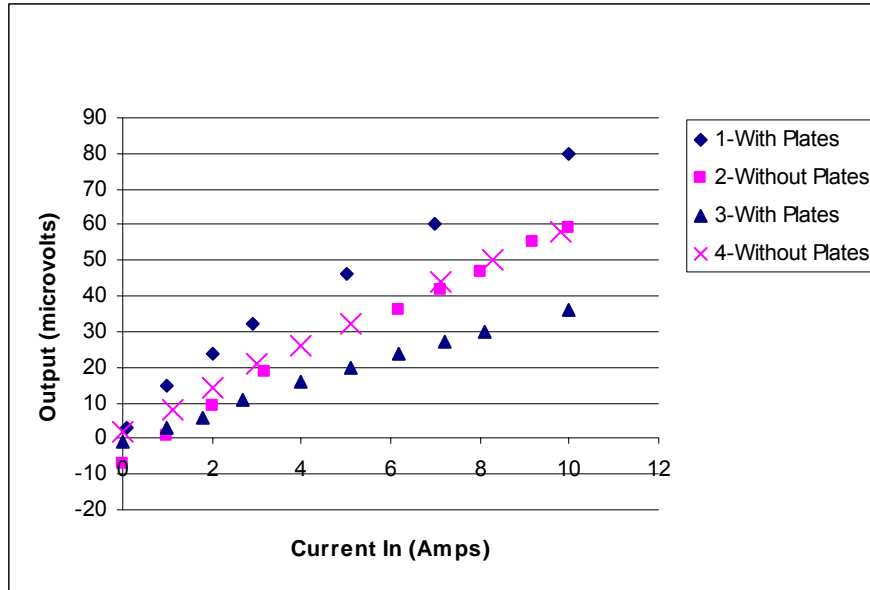

**Figure 8. Voltage Output with and without Plate Electrodes**

It is clear from Figure 8 that there is no direct correlation between the magnitude of the voltage and the use of large plate electrodes. This evidence gave us the confidence to proceed in designing a flow meter that does not require the use of large plate electrodes.

*Heat Transfer Model for Test Loop*

In order to address the question of how to heat the flow circuit, we surveyed a few ideas ranging from modifying a barbecue to using heat tape. Because of the low-cost and quick setup of heating tape, we determined that it would be the most feasible way to heat the circuit. In order to determine the required power input, we developed a heat transfer model to calculate how much power would be needed to maintain the loop at various temperatures.

Because of the high thermal conductivity and high velocity of the liquid metal, the pipe was assumed to be a constant temperature along its length. The pipe was then treated as a heated cylinder, cooled by natural convection and radiation. While this analysis has several simplifying assumptions, it provides a “worst-case” scenario so we know what range of heat transfer to expect. The governing equations are as follows:

$$Ra_D = \frac{g\beta(T_s - T_\infty)D^3}{\nu\alpha}$$

$$\overline{Nu}_D = \left[ 0.60 + \frac{0.387Ra_D^{1/6}}{\left[ 1 + (0.559 / Pr)^{9/16} \right]^{8/27}} \right]^2$$

$$\bar{h} = \frac{k}{D} \overline{Nu_D}$$

$$q' = q'_{conv} + q'_{rad} = \bar{h}\pi D(T_s - T_\infty) + \varepsilon\sigma\pi D(T_s^4 - T_\infty^4)$$

Where properties and constants are calculated at the film temperature, which is the average of the surface and free stream temperatures. Solving these equations at various temperatures produced the relationship between surface temperature and heat flux shown in Figure 9.

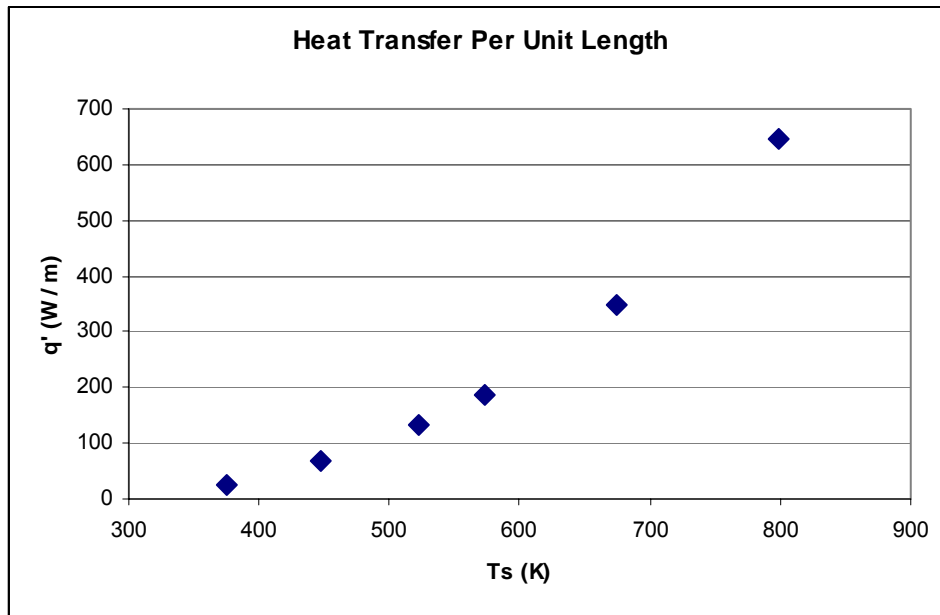

**Figure 9. Relationship between surface temperature and heat flux**

After looking at this model and the prices of different types of heating tape, we chose to buy two sections of heating tape each 4 feet long and delivering 600 Watts. These tapes will allow us to quickly heat the fluid system, and easily make up for any thermal losses from both the tape, and the heated pipe. Once the heating tape is installed, we can determine experimentally how much current should be applied to maintain a specific desired temperature, using this thermodynamic model as an initial reference (*see Appendix for complete model*).

## Prototype Hardware

Numerous prototypes and experiments have influenced the current design. The current prototype design (see *Figure 10*) is composed of flexible low density PVC piping with two stainless steel electrodes positioned inside the pipe. A rod connected to each electrode penetrates through the pipe to allow for voltage measurements. Two permanent magnets have also been positioned in a perpendicular orientation to the electrodes.

This design is very similar to the final design which will consist of a ceramic pipe section composed of Macor, a material that meets our design criteria for maximum temperature, thermal expansion and corrosion.

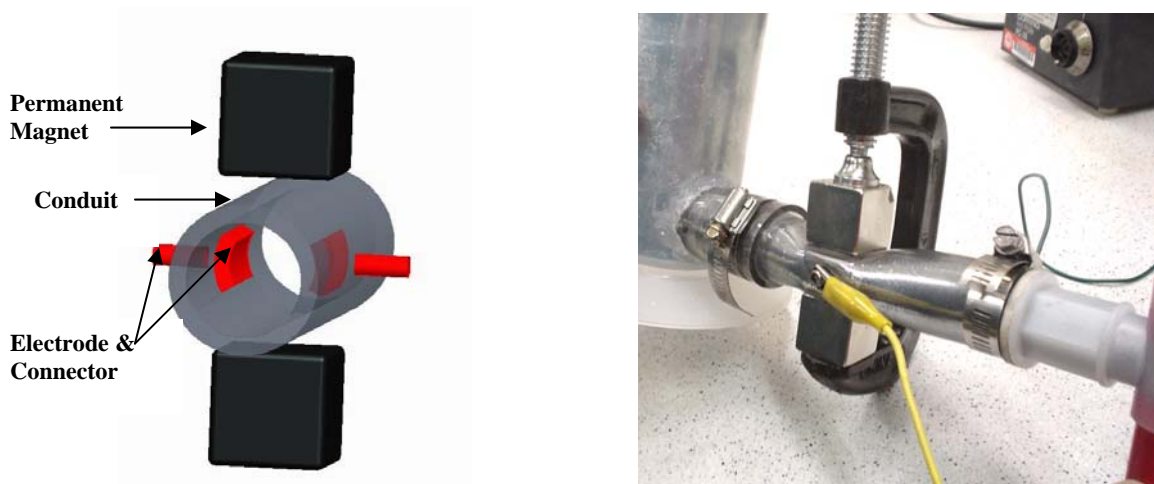

**Figure 10: Preliminary Flow Meter CAD Design (left) and Prototype (right)**

The prototype design is limited in several ways, but we are confident that the necessary modifications can be implemented to overcome any limitations.

First, the PVC piping is incapable of functioning from 300 to 800°C, which is the final temperature range specified by our sponsor. Our final design must include a pipe that is electrically nonconductive and capable of surviving at elevated temperatures. Our current solution to this problem is the inclusion of a ceramic tube section composed of Macor.

A second concern is that the plastic piping may leak fluid along the penetrating electrodes. In the prototype design, the use of clamping force, washers and Teflon tape has provided sufficient sealing. In the ceramic design, the electrodes will be bonded to the ceramic with Ceramabond coupled with a layer of Pyropaint applied to the outer surface to prevent wetting. The electrodes are composed of stainless steel, which has greater thermal expansion than most ceramics. The ceramic material, Macor, has a coefficient of thermal expansion that is close to stainless steel. Through interference fit modeling, it has

been determined that this characteristic will eliminate any potential problems associated with material matching.

Another concern deals with the possible signal drift associated with the use of permanent magnets as the source of magnetic flux. The use of electromagnets with pulsed excitation current to provide magnetic flux is a possible solution to this problem. The pulsed nature of the excitation will allow for bias compensation. If signal drift occurs, the use of electromagnets will be implemented in the proposed design. Initially, we are planning to use a custom electromagnet, designed last semester, to eliminate the anticipated signal drift. This electromagnet was initially designed for pump applications and is too large for the flow meter. For final testing a smaller custom electromagnet will be designed.

A final concern is the small magnitude of the output voltage generated in the flow sensor. The voltage output of the flow meter operating with flow speeds of three to five meters per second is expected to be less than 100 micro volts. As demonstrated by the developed hardware, the implementation of an amplifier in the data acquisition system converts this small voltage into easily readable levels.