

Report
To the U.S. Department of Energy
Small Business Innovation Research (SBIR)

Grant No: DE-FG02-03ER83740

Development of a Method for Measuring Carbon Balance in Chemical Sequestration of CO₂

A Report Submitted to:

Dr. John Shen,
Program Manager
U.S. Department of Energy
John.shen@hq.doe.gov
Tel: (301) 903-4344

Submitted by:

Dr. Zhongxian Cheng
Dr. Wei-Ping Pan
Institute for Combustion Science and Environmental Technology
Western Kentucky University, Bowling Green, KY 42101
Tel: (270) 780-2532, Mobile: (270) 792-3776, Fax: (270) 780-2569
E-mail: wei-ping.pan@wku.edu

and

Dr. John T. Riley
Paras Research Corporation
1511 Woodhurst Street, Bowling Green, KY 42104
Tel: (270)842-2757
E-mail: bgrileys@incsigthbb.com

September 6, 2006

EXECUTIVE SUMMARY

Anthropogenic CO₂ released from fossil fuel combustion is a primary greenhouse gas which contributes to “global warming.” It is estimated that stationary power generation contributes over one-third of total CO₂ emissions. Reducing CO₂ in the atmosphere can be accomplished either by decreasing the rate at which CO₂ is emitted into the atmosphere or by increasing the rate at which it is removed from it. Extensive research has been conducted on determining a fast and inexpensive method to sequester carbon dioxide. These methods can be classified into two categories, CO₂ fixation by natural sink process for CO₂, or direct CO₂ sequestration by artificial processes.

In direct sequestration, CO₂ produced from sources such as coal-fired power plants, would be captured from the exhausted gases. CO₂ from a combustion exhaust gas is absorbed with an aqueous ammonia solution through scrubbing. The captured CO₂ is then used to synthesize ammonium bicarbonate (ABC or NH₄HCO₃), an economical source of nitrogen fertilizer. In this work, we studied the carbon distribution after fertilizer is synthesized from CO₂. The synthesized fertilizer in laboratory is used as a “CO₂ carrier” to “transport” CO₂ from the atmosphere to crops. After biological assimilation and metabolism in crops treated with ABC, a considerable amount of the carbon source is absorbed by the plants with increased biomass production. The majority of the unused carbon source percolates into the soil as carbonates, such as calcium carbonate (CaCO₃) and magnesium carbonate (MgCO₃). These carbonates are environmentally benign. As insoluble salts, they are found in normal rocks and can be stored safely and permanently in soil.

This investigation mainly focuses on the carbon distribution after the synthesized fertilizer is applied to soil. Quantitative examination of carbon distribution in an ecosystem is a challenging task since the carbon in the soil may come from various sources. Therefore synthesized ¹⁴C tagged NH₄HCO₃ (ABC) was used. Products of ammonium bicarbonate (ABC) or long-term effect ammonium bicarbonate (LEABC) were tagged with ¹⁴C when they were synthesized in the laboratory. An indoor greenhouse was built and wheat was chosen as the plant to study in this ecosystem. The investigated ecosystem consists of plant (wheat), soils with three different pH values (alkaline, neutral and acid), and three types of underground water (different Ca²⁺ and Mg²⁺ concentrations). After biological assimilation and metabolism in wheat receiving ABC or LEABC, it was found that a considerable amount (up to 10%) of the carbon source is absorbed by the wheat with increased biomass production. The majority of the unused carbon source (up to 76%) percolated into the soil as carbonates, such as environmentally benign calcium carbonate (CaCO₃). Generally speaking, alkaline soil has a higher capability to capture and store carbon. For the same soil, there is no apparent difference in carbon capturing capability between ABC fertilizer and LEABC fertilizer.

These findings answer the question how carbon is distributed after synthesized fertilizer is applied into the ecosystem. In addition, a separate post-experiment on fertilizer carbon forms that exist in the soil was made. It was found that the up to 88% of the trapped carbon exists in the form of insoluble salts (i.e., CaCO₃) in alkaline soils. This indicates that alkaline soil has a greater potential for storing carbon after the use of the synthesized fertilizer from exhausted CO₂.

Table of Contents

1. Background.....	3
1.1 Global Warming and Carbon Dioxide Green House Gases (GHG)	3
1.2 Approach Applied in this Work- Sequestration in the ecosystem.....	4
1.2.1 CO2 Capture.....	5
1.2.2 Short Term Storage.....	6
1.2.3 Long Term Storage.....	7
2. Experimental Development.....	8
2.1 Sampling Plan Development.....	8
2.1.1 Sample Selection.....	8
2.1.2 Greenhouse Design	10
2.1.3 Sampling Plan	13
2.2 Analytical Methods.....	14
2.2.1 Experiment Protocols.....	14
2.2.2 Instruments for C-14 Detection and Preparation of C-14-labeled NH_4HCO_3 ...	15
2.2.3 Analytical Method	16
3. Results and Discussion.....	21
3.1 Local Rainfall/Snow Collection and Analysis.....	21
3.2 Soil Properties.....	21
3.3 Groundwater Properties.....	22
3.4 Fertilizer Leaching Test.....	22
3.5 Synthesis of $\text{NH}_4\text{H}^{14}\text{CO}_3$ and Long-term Effect $\text{NH}_4\text{H}^{14}\text{CO}_3$ Fertilizer.....	24
3.6 Carbon Distribution.....	28
3.6.1 Carbon Stored in Soil.....	28
3.6.2 Carbon Stored in Plants.....	29
3.6.3 Carbon Stored in Underground Water.....	29
3.6.4 Carbon Released in Air or Lost.....	30
3.6.5 Different Effect on Carbon Storage between ABC and LEABC	30
3.6.6 Carbon Storage Effects among Different soils	31
3.7 Carbon Forms Existing in Soil and Calcium Availability	31
3.8 Carbon 14 Tracer Technique.....	33
4. Conclusions.....	33
5. References.....	34

1. Background

1.1 Global Warming and Carbon Dioxide Green House Gases (GHG)

It is well known that greenhouse effects lead to “global warming,” which severely threatens our environment. It is predicted that greenhouse gases such as carbon dioxide (CO₂) could increase the average global temperature 1.5 to 4.5°C and the sea level 0.25 to 0.5 m [1]. It is estimated that CO₂ makes the largest contribution (63%) to this climate change and is regarded as the primary greenhouse gas [2]. Each year, over 20 tera (20 x 10¹²) tons of CO₂ are released into the atmosphere as combustion exhaust [3]. Since the beginning of the industrial era, CO₂ concentration in the atmosphere has risen from 280 ppm to 360 ppm [4]. The famous “*Kyoto Protocol*” commits the developed countries to reduce greenhouse gas emissions by 5.2% of their 1990 level by 2012 [1].

Stationary power generation contributes over one-third of the anthropogenic CO₂ released from fossil fuel combustion [5], which raises an uncertainty about future generation of CO₂ through combustion. The goal of reducing CO₂ concentrations in the atmosphere can be met either by decreasing the rate at which CO₂ is emitted into the atmosphere or by increasing the rate at which it is removed from it [1]. Extensive research has been conducted on determining a fast and inexpensive method to sequester carbon. These methods are roughly classified into two categories [6], CO₂ fixation by natural sink processes for CO₂, or direct CO₂ sequestration by artificial processes. The natural sink processes are the formation of fuels via photosynthesis and rock weathering. The relevant options are ocean fertilization and mineral carbonate. The atmospheric CO₂ would be fixed after conversion to more stable forms such as organic matter or carbonates, to be sequestered. Weather or natural carbonation is a very slow process and may take hundreds of years. In direct sequestration, CO₂ produced from sources such as coal-fired power plants, would be captured from the exhaust gases. A number of capturing techniques including absorption/stripping, adsorption/desorption, and membrane separation [6] have been proposed and developed, including the use of chemical solvents, physical adsorption, and cryogenic methods [7,8]. Physical solvents are favored by high pressures and low concentrations of inert gases. CO₂ can be physically absorbed in a non-reactive solvent according to Henry’s Law and then regenerated using pressure reduction or heating. Chemical solvents are preferred for cases with low concentrations or amounts of CO₂ in the combustion gases and do not gain significant advantage by operating at elevated pressures. The chemical solvent methods are generally recognized as the most effective technologies at present. However the cost for separation of CO₂ is high, typically in the range \$40-200/ton of carbon [9]. The chemical solvent method also has some major problems, such as a slow absorption rate, small solvent capacity, and special equipment requirement. Currently, the monoethanolamine (MEA) process is being widely used for CO₂ capture and regeneration. But this is an expensive option. Low cost and high capacity solvent is becoming the goal for chemical separation of CO₂.

Current commercial approaches in the fertilizer industry which involves the reaction between CO₂ and NH₃ may provide an inexpensive and effective route of reducing CO₂ emissions from power plants [10]. NH₃ scrubbing capacity based on breakthrough curves is around 0.35 mol CO₂/mol NH₃ on a molar basis or 0.9-1.2 kg CO₂/kg NH₃ on a mass basis. The removal efficiency is approximately 99% and the CO₂ loading capacity can approach 1.2 kg CO₂/kg NH₃ [11-12]. The maximum CO₂ removal efficiency and loading capacity by MEA absorbent is 94% and 0.40 kg CO₂/kg MEA. A multi-pollution control concept with spraying

aqueous ammonia into actual flue gas to capture CO₂, SO₂ and NO_x emissions was proposed and developed [13] and the capture efficiency of CO₂ in the absorber was in the range of 76% - 91% at 35°C.

The products in the aqueous scrubber could include ammonium bicarbonate (NH₄HCO₃, also called ABC), ammonium carbonate (all in crystalline or aqueous solution), plus reagents CO₂, NH₃, and NH₄OH. Of these by-products, ammonium bicarbonate has been utilized by certain developing countries as a crop fertilizer [14] for over 30 years. Also the ammonia (NH₃) in ammonium bicarbonate can be regenerated easily [11]. Therefore aqueous ammonia scrubbing techniques presents many advantages such as lower cost, higher loading capacity, higher CO₂ adsorption efficiency, lower decomposition temperature and less corrosive environment for CO₂ capture over MEA.

The aqueous ammonia scrubbing process is assumed to be a very promising technique for CO₂ sequestration from flue gas. However, this type of CO₂ removal is best for systems that have the characteristics of low CO₂ concentration and operate at atmospheric pressure, high temperature and have a high volume flow rate. Continuous operation and a large capacity of CO₂ sequestration are highly desirable for practical application of this technique in power plants.

1.2 The Approach Applied in this Work -- Sequestration in the Ecosystem

In this work, we studied carbon distribution in a closed ecosystem (air, plants, soil, underground water) after NH₄HCO₃ is synthesized from CO₂. The process of CO₂ capture and storage in this work is shown in Figure 1. It consists of three stages: CO₂ capture to form fertilizer; CO₂ storage by photosynthesis to form biomass; and insoluble salt formation in soil/under groundwater. Quantitative examination of carbon distribution in an ecosystem is a challenging task since carbon contents from the original ecosystem and from the added fertilizer need to be accurately and separately measured and quantified. Instead of using regular carbon, isotopic ¹⁴C tagged NH₄H¹⁴CO₃ was synthesized in the laboratory. CO₂ in combustion exhaust gas was absorbed with aqueous ammonia solution through scrubbing. The captured CO₂ was then used to synthesize ammonia bicarbonate (NH₄HCO₃), an economic source of nitrogen fertilizer. This fertilizer was used as a “carrier” to “transport” [15] CO₂ from the atmosphere to crops. After biological assimilation and metabolism of crops applied with NH₄HCO₃, a considerable amount of the carbon source is absorbed by plants with an increase in the amount of biomass production. The majority of the unused carbon source percolates into the soil as carbonates, such as calcium carbonate (CaCO₃) and magnesium carbonate (MgCO₃). These carbonates are environmentally benign. As insoluble salts, they are found in normal rocks and can be stored safely and permanently in soil. An important point of this work is to transform CO₂, a greenhouse gas, into a profitable fertilizer.

Fertilizer NH₄HCO₃ is a white solid at room temperatures and ambient pressures. This unique feature makes the transportation and application of NH₄HCO₃ as a CO₂ carrier much easier and more cost-effective. In order to further improve the stability of NH₄HCO₃, dicyandiamide was added during the synthesis process and forms long-term effect ammonia bicarbonate (LEABC) [14]. LEABC considerably prolongs the effective time of ABC and increases its nitrogen utilization efficiency by inhibiting the natural decomposition reaction. Moreover, LEABC can enhance the chemical reactions to form insoluble carbonate salts. Thus, the total CO₂ sequestration is significantly improved.

Key questions to be answered are, after NH_4HCO_3 (ABC) or LEABC is applied to plants, how much of the carbon source can be stored in plants as uptake, how much is stored as insoluble carbonate salts in soil and in underground water, and how much is released back to the atmosphere as CO_2 gas. The radioactive isotope tracing method for monitoring the fate of carbon after the fertilizer is applied was the best choice. Fertilizer NH_4HCO_3 (ABC) and LEABC used here were ^{14}C -tagged and carbon distribution in samples can be detected using a liquid scintillation counter (LSC). Thus, the carbon distribution of the fertilizer applied to plants can be determined. A detailed protocol to study carbon distribution using radioactive isotopes was developed in this work.

The process of CO_2 capture and storage in the proposed project can be divided into three stages, which include two cycles (see Figure 1) [16]. In the first stage, CO_2 Capture, the CO_2 in power plant flue gas is captured by ammonium scrubbers and forms a fertilizer. The second stage, Short Term CO_2 Storage, focuses on how the captured carbon-fertilizer enhances plant photosynthesis to form biomass. The third stage involves another cycle, in which carbon in the soil system percolates to meet alkalis in the soil and groundwater to form a permanent storage system.

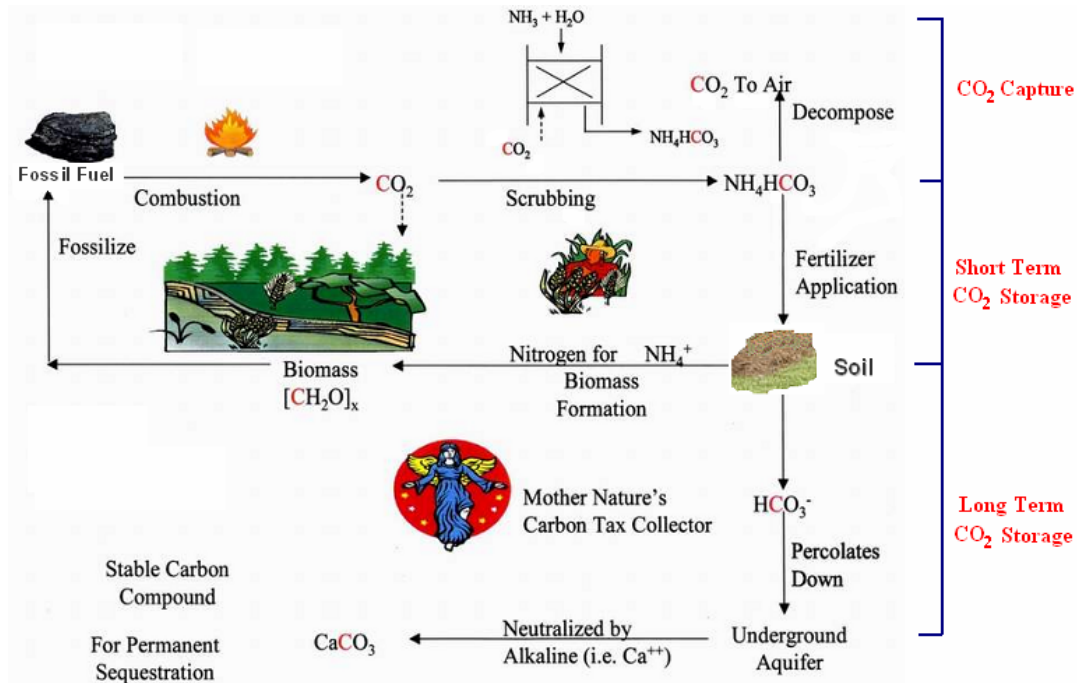

Figure 1. The proposed three stages of sequestering CO_2 by the ecosystem

1.2.1 CO_2 Capture

With regard to the high rate of CO_2 generation and relatively slow rate of converting gaseous CO_2 to organic carbon or carbohydrates, $(\text{CH}_2\text{O})_x$, by photosynthesis, research on faster CO_2 sequestration by chemical or physical means from the source of combustion (i.e. the

stationary power plants) is highly desirable. The use of inorganic chemical routes to sequester CO₂ is merely a new route to supplement the slow photosynthesis process.

By taking advantage of the acidic nature of CO₂ in aqueous media, ammonia/water liquors are good choices for chemical absorption, where NH₃ is used to scrub out CO₂ in solid forms as ammonium bicarbonate (NH₄HCO₃) and carbonate ((NH₄)₂CO₃), as illustrated by the following equations:

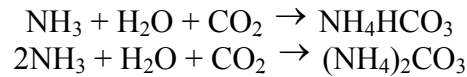

This process offers the possibility of much lower costs during the regeneration phase due to the higher CO₂ loading capacity of aqueous ammonium compared to other scrubbing solutions. In the work by Bai and Yeh [11], based on breakthrough curves, the NH₃ scrubbing capacity was calculated to be around 0.35 mol of CO₂/mol of NH₃ on a molar basis, or 0.9 -1.2 kg of CO₂/kg of NH₃ on a mass basis. The removal efficiency is approximately 99%. In the work by Smouse [17], a multi-pollution control concept involving spraying aqueous ammonia into actual flue gases to capture CO₂, SO₂ and NO_x emissions was proposed and developed. The capture efficiency of CO₂ in the absorber was in the range from 76.4-91.7% at 35°C. In addition, the aqueous ammonia flue gas scrubbing process will also remove other acid gases, such as HCl and HF, as illustrated by the following equations:

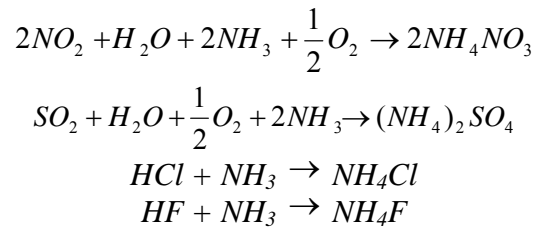

All the salts of ammonium, such as bicarbonate, carbonate, sulfate and nitrate are known to be nitrogen fertilizers. They serve as vehicles or catalysts for nature's photosynthesis process and help keep carbon in the organic form in soil, both in quantity and duration.

1.2.2 Short Term Storage

As a baseline for judging carbon sequestration potential, an understanding of inherent ecosystem productivity is necessary and important. Based on a review and analysis of micrometeorological and canopy-enclosure measurement data, Ruimy et al. [17] concluded that photosynthetic capacity per unit ground area (i.e., CO₂ uptake at high irradiation, ~1800 μmol photons PAR/m² sec) is greatest in crops. It can be predicted that there will be an enhanced interest to study the carbon absorption by crop plants.

Once the ammonium bicarbonate fertilizer is applied to the soil, it dissociates or ionizes into two ions, the ammonium (NH₄⁺) and the bicarbonate (HCO₃⁻) ions. These two ions play distinct roles in carbon dioxide sequestration. The ammonium ion participates as a nitrogen fertilizer which enhances the carbon cycle, a biological change from CO₂ and water into

biomass, $[\text{CH}_2\text{O}]_x$. With the proper application of fertilizer, more biomass can be produced due to the enhanced photosynthesis process. As a result, more CO_2 can be removed from the atmosphere and form organic carbon. The total carbon inventory in the atmosphere would be reduced. This may give the Earth a reprieve from rapid and excessive CO_2 build-up in the atmosphere. Thus, the greenhouse effect would be reduced gradually.

The management of soil fertility, including the balances of N, P, S, K, etc., in agricultural production was also studied. It has been reported that plants can take up about 833 Kg of N, 200 Kg of P, and 143 Kg of S to sequester 10000 Kg of C in soil humus. Although K is not a constituent element in soil organic matter, it can improve CO_2 photosynthesis and enhance photosynthesis transportation from above ground to root-soil.

The generated biomass either can be used as fuel, or can stay in the terrestrial system as soil organic matter. No matter whether it is used as fuel or fossil fuel, when it is burned, CO_2 is released again and eventually returns to the atmosphere. Reviewing the movement of carbon in this cycle, it is clear that it takes years, or hundreds of years, for the atmospheric carbon to be utilized by plants and then return to the atmosphere. Thus, the carbon storage in this cycle has been called “short-term carbon storage”. The net storage amount depends on the ratio of biomass production and consumption.

1.2.3 Long Term Storage

After ammonium bicarbonate fertilizer (ABC) is applied to soil, NH_4^+ is taken up by plants as a nutrient. Another part of the fertilizer, the bicarbonate (HCO_3^-) ion, most likely remains in the soil and reacts with free alkali to form precipitated salts, or move with the groundwater down into the aquifer. Since HCO_3^- is a weakly acidic ion, it may react with all free alkali. Depending on the free alkalinity of the soil, the resultant salt could be Na_2CO_3 , K_2CO_3 , CaCO_3 , MgCO_3 , and so on. Among them, CaCO_3 , ZnCO_3 and MgCO_3 are nearly water-insoluble [18]. The carbon in such chemical compounds is securely stored in natural soil.

The aquifer contains a significant amount of highly alkaline compounds. It neutralizes the bicarbonate ion and forms stable carbonate salts, i.e., calcium carbonate, or limestone, whose ample supply is seen in caves. The reaction is represented by the following equations:

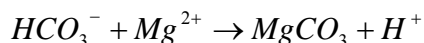
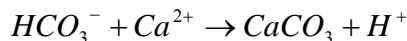

Since CaCO_3 and MgCO_3 are very stable chemical compounds, the CO_2 can be fixed in soil or groundwater. Carbon fixation through calcium carbonate or magnesium carbonate formation, therefore, is called ‘long term CO_2 storage’.

This study shows a novel idea to capture CO_2 from the atmosphere and store it into the ecosystem. Both short term storage and long term storage are part of the proposed ecosystem carbon sequestration. While each part has distinct roles, the integrated purpose is to capture CO_2 from the atmosphere and store it securely. Through fertilizer application, the approach does not require any significant cost but can win carbon credits.

2. Experimental Development

2.1 Sampling Plan Development

2.1.1 Sample Selection

The apparatus for simulating an ecosystem to study the carbon cycle and balance is a complex and dynamic physical-chemical-biological system. The challenge is how to select the testing components to represent the real world. In this research, the ecosystem is divided into four subsystems: community of crop plants being grown, soil, atmosphere and groundwater. Many reactions and interactions both within and between these subsystems are also expected. For example, the yield of a given plant species obtained from a given amount of fertilizer depends not only on nutrient availability in the surface soil, but also on nutrient availability in the subsoil, the plant population, moisture and temperature conditions and many other factors. In developing the relationships needed to interpret measurements of any variable in the system, the entire system has to be evaluated.

2.1.1.1 Soil Sample Selection

Soil is the natural medium for the growth of land plants, whether or not it has discernible soil horizons. Experience has shown that no useful generalizations about single characteristics can be made for all soils. Characteristics are given weight according to the knowledge gained through research and experience in soil genesis and the responses of soil to management or manipulation.

Soils were collected from the Western Kentucky University farm. First the samples were dried by air to reduce moisture. Based on soil distribution information in the U.S. [18] from a national cooperative soil survey and distribution of soil in the world and in the U.S. and its territories, the selected soil used for this work is close to Alfisol soil. Alfisol is mainly located in north central U.S. from semiarid to humid areas, where clay and nutrient-enriched subsoil dominates, and average annual precipitation is 500-1300 mm. It commonly has a mixed vegetative cover and is productive for most crops. Alfisol has moderate organic matter accumulation, and shows a gray to brown color. It is usually leached and acidic, and occurring where at least three months of growing season are cool and moist. Three areas are dominated by Alfisol, the hilly region north of Portland, the area northeast of Moscow; and the mountains near the eastern boundary of Idaho.

2.1.1.2 Plant Selection

Based on a review and analysis of micrometeorological and canopy-enclosed measurement data, photosynthetic capacity per unit ground area is greatest in crops, followed by grasslands and forests. Crop plants are very sensitive to the CO₂ concentration in the atmosphere, and have a great ability to absorb CO₂. In this work, wheat was selected to monitor its utilization of carbon and their response to the use of ammonium bicarbonate fertilizer. The factors used for plant selection should be popular in distribution and important in agriculture. As illustrated in Figure 2, the production of wheat, rice, corn, barley, sorghum, soybean, cotton, oats, beans and potatoes

account for the largest land use around the world [19]. Wheat, corn, rice, beans, barley are considered to be the leading plants in agriculture.

Wheat is one of the leading plants in the crop family, which needs nitrogen fertilizer during its seeding and growth. Ammonium bicarbonate is a good fertilizer for wheat. Another physiological feature of the wheat plant is that wheat has a very shallow root system and short haulm, which is suitable for growth in a green house. Wheat prefers neutral or alkaline soil. It also has reasonable temperature and humidity requirements.

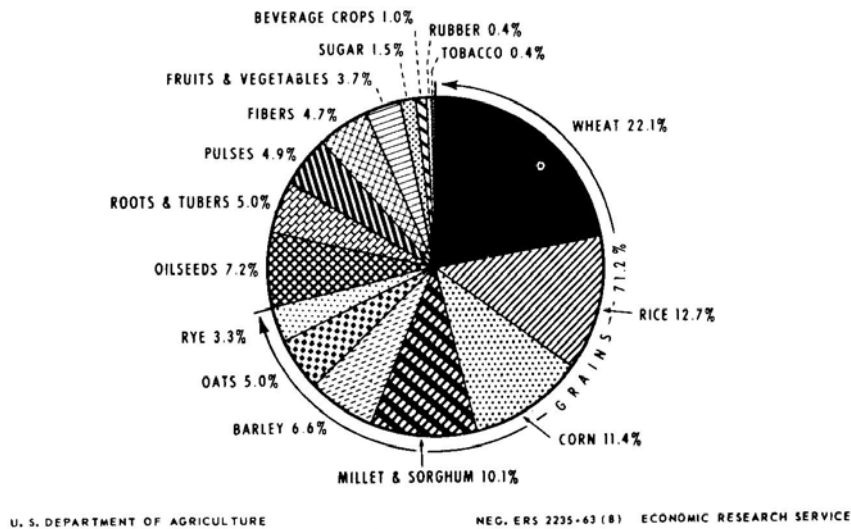

Figure 2. Field crops (exclusive of foraging) and land use.

Wheat was selected as the test plant in this research. Its response to ABC fertilizer was carefully investigated. In addition, the plant culture was also involved in the study. The best plants for carbon sequestration studies must have high carbon content, but also should have a high ratio of root to stalk. Incorporating soil organic carbon into the subsoil by growing deep-root plants can increase organic carbon mean residence time (MRT). Therefore, the physical parameters of selected crop plants was studied as well.

2.1.1.3 Groundwater Selection

It has been shown from hydrological studies that groundwater is commonly 1 to 10 meters below the soil surface in humid regions, but may be several hundred or even thousands of meters deep in arid region. Groundwater consists of both shallow groundwater and deep groundwater. Shallow groundwater serves as a recipient of downward-percolating drainage water, which in turn replenishes the deeper groundwater. When the irrigation or precipitation water moves downward and out of the soil, it first becomes shallow groundwater, but it will take a long journey to continue to move down and reach deep groundwater.

Surface water (~ 0 feet deep), underground river water (~ 350 ft deep) and cave water (~ 500 ft deep) were selected to represent three different groundwater sources from shallow to deep water for testing.

All water was sampled at the Mammoth Cave National Park. The laboratory analysis results indicated that all underground waters are weakly alkaline. The contents of Ca^{2+} and Mg^{2+} in underground river water are higher than well water.

2.1.1.4 Fertilizer Selection

Ammonium bicarbonate (ABC), as a final product for the flue gas clean-up process, has been used as a nitrogen fertilizer in many countries since the 1980's. Although modern fertilizers, such as urea, ammonium nitrate and ammonium sulfate, are formidable competitors for ABC because they contain more nitrogen and are more stable, ABC is still used widely since it is less expensive than other nitrogen fertilizers. Recently, China has produced a so-called Long-effect Ammonium Bicarbonate (LEABC), which is a stabilized form of ABC by the addition of a dicyandiamide, DCD [15]. Compared to conventional nitrogen fertilizers such as urea, ammonium nitrate and ammonium sulfate, the utilization of LEABC has generated a very favorable environmental impact.

To test ammonium bicarbonate (ABC) fertilizer utilization, as well as the comparison with long effective ammonium bicarbonate (LEABC), both ABC and LEABC were chosen as the test materials. In addition, to trace the carbon movement in the ecosystem, ammonium sulfate was also be used in study. Since the ammonium sulfate does not contain carbon, therefore, it can be a base to show the carbon movement in studies using ABC or LEABC utilization.

The amount of N, P and K nutrients needed for the soil was determined to be: 0.13 g N/kg soil, 0.08 g P_2O_5 /kg soil and 0.08 g K_2O /kg soil. The equivalent fertilizer amounts were 0.765 g NH_4HCO_3 /kg soil, 0.16 g KH_2PO_4 /kg soil and 0.064 g K_2SO_4 /kg soil. No deficiency symptom was found for N, P and K nutrition and micro-nutrition during the 40-day growth periods.

2.1.2 Greenhouse Design

In order to assure the reliability of the proposed method to securely sequester CO_2 in soil and groundwater, it was essential to verify and monitor such sequestration. A lab-scale in-door greenhouse was set up. An indoor greenhouse consists of high intensity light system, six triple-growth chambers, air supply system, CO_2 trapping system and an irrigation system. One corner of the green house is shown in Figure 3.

2.1.2.1 Growth Chambers

Each growth chamber (see Figure 4) includes three individual growth cells. The chamber size is 91 cm (length) \times 31 cm (width) \times 76 cm (height). Each individual cell of the triple-cell has soil and groundwater separated from each other, but three cells share the same air layer to reduce sampling load. The ground water layer of each cell holds a different type of water. The layout of this combined system can represent the case for crop planting in the same air system,



Figure 3. A corner of the indoor greenhouse.

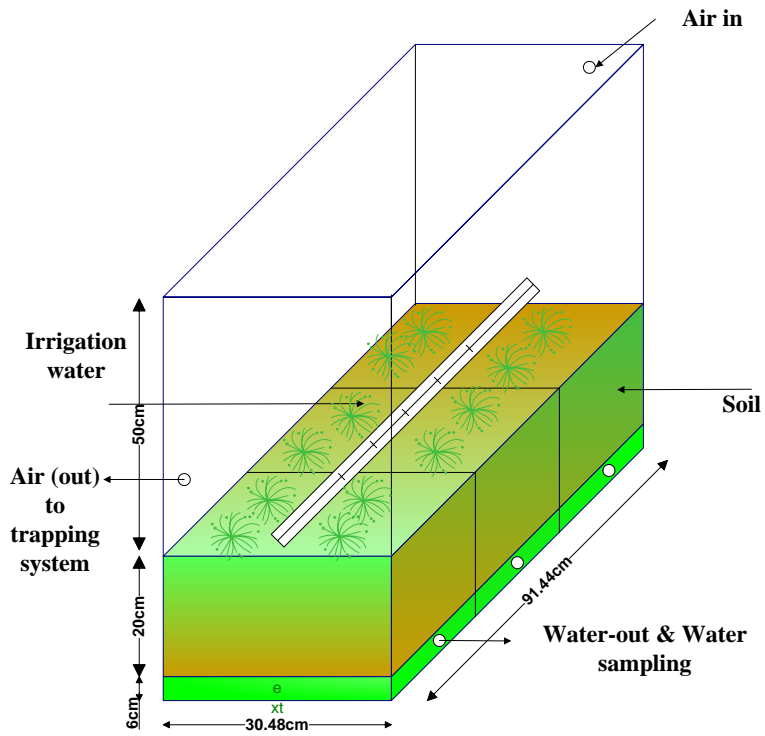

Figure 4. A schematic of the triple-growth chamber

but in different soil and groundwater ecosystems. All the ports for air and water injection were designed with one way, quick-disconnect couplings to prevent radioactive $^{14}\text{CO}_2$ leakage during operation. Plants grew in each unit cell with sufficient sunshine, nutrition and moisture.

2.1.2.2 Indoor HID Growth Lights

HID (High Intensity Discharge) growth lights were used to insure indoor crops' healthy growth. There are two types of HID growth lights used currently for horticultural lighting: metal halide and high pressure sodium. Metal halide bulbs produce an abundance of light in the blue spectrum. This wavelength of light promotes plant growth and is excellent for green leafy plant growth and keeping plants compact. It is the best type of the light to be used as a primary light source (if little or no natural sunlight is available). High-pressure sodium bulbs emit an orange-red glow. This band of light triggers hormones in plants to increase flowering/budding in plants. They are the best lights for secondary or supplemental lighting (used in conjunction with natural sunlight). This is ideal for greenhouse growing applications.

2.1.2.3 Irrigation System

It is very important to design the irrigation system properly before planting in a closed cell. Water stress occurs not only due to an insufficient supply of water, but also can result from excess water (flooding). Flooding causes plant roots to suffer from lack of oxygen that is required for proper root function. Generally speaking, a soil's moisture in the greenhouse should be kept at a level of 60-70% of the soil's water capacity in order to meet the needs of the plants for optimum growth. In order to simulate real ecosystem conditions, the average annual precipitation in the Bowling Green locality (1265 mm or 49.8 inches) was used as the criteria for the irrigation system in the growth cell.

Pipe sprinklers with parallel fine holes were made. These pipe sprinklers were placed on the soil surface. Water was injected into the pipe sprinklers with a syringe that could avoid radioactive $^{14}\text{CO}_2$ leakage and also precisely count the amount of water added.

2.1.2.4 Air Supply System

Plants need CO_2 for photosynthesis during growth as well as oxygen for the development of their roots. An air supply of 8-12 liters/day, which was by measured by mass flow controllers, was added to each growth cell. CO_2 concentration was maintained at an appropriate level. Previous research indicates that the net photosynthesis rate of leaves is positive if the CO_2 concentration is below 1000 mL/m^3 . The saturation point of CO_2 concentration for plant growth is 1600 mL/m^3 . Beyond this saturation point, plant growth may be inhibited. Therefore, the CO_2 concentration in the closed growth cell during the entire growth period was monitored closely by a portable CO_2 analyzer to maintain the concentration at the appropriate level. In order to prevent the outlet gas of this analyzer from diffusing into ambient air, the CO_2 analyzer was placed in a clear sealed plastic bag. The air in this sealed bag was sucked back to a closed growth cell by a special syringe.

2.1.2.5 *CO₂ Trapping System*

With a continuous supplement of fresh air for the closed system, the pressure could build up. In order to avoid this build up, a special CO₂ trapping system was designed to release pressure. It consists of three-stage impingers. Overflow gases that contain ¹⁴CO₂ are trapped completely in 1 M NaOH solutions after three stages. Other escaped gases from the NaOH solution are directed into fume hoods directly. Impingers also have valve-controlled openings in the bottom. Another main function of these impingers is to collect the solution with ¹⁴C during the experiment or at the end of the experiment for LSC analysis.

2.1.2.6 *Groundwater Trapping*

All of these groundwater sources are located in the Mammoth Cave National Park. Groundwater is placed under the bottom of the growth chamber. A screen with filter was placed at the bottom of the chamber to separate the soil and groundwater, which will hold soil, but allow water to seep into the soil. The groundwater used contains more Ca²⁺ and Mg²⁺ than that in rainwater in Bowling Green, KY. The concentration of Ca²⁺ and Mg²⁺ in the groundwater ranges from 46-60 ppm to 6-11 ppm.

The plants were seeded in pots according to the seeding population, which is 10 ~12 seeds/ft² for wheat. The unit cells were closed during the experimental period.

2.1.3 *Sampling Plan*

In order to simulate an ecosystem, the soil, plant, and groundwater were prepared prior to the experiment. The sampling plan includes field sampling and laboratory sampling. Field sampling includes soil and groundwater sampling from the field. Laboratory sampling includes air, plant, soil and groundwater sampling for laboratory analysis purposes.

2.1.3.1 *Soil Sampling in the Field*

Since soils are naturally variable horizontally as well as vertically, sampling techniques require careful consideration. In observing short-term changes in agricultural land (5 to 10 years), the greatest change in most crops will be in the top 0.6 ft to 1 ft. For most carbon sequestering studies, determining changes to 1.6 ft should be sufficient [20].

A 16 ft × 16 ft site was selected for sampling. The number of cores needed to constitute a single sample composite is not a fixed number but varies depending on site variability and statistical factors. Four locations in this area were set up and the sampling area for each location was 3 ft × 3 ft. The sampling depth was up to 2 ft. In addition, a completed soil column to show the soil profile in the vadose area, moisture and chemical contents distribution was taken.

The collection of soil samples was a disruptive procedure as the material is extracted from its natural environment and then transported from the site to a laboratory for analysis. Normally, in this highly variable type of material, the adjacent soil profile is not precisely the same as the sampled soil. For these reasons, when soil samples were removed, the same material cannot be collected from the site later. Therefore, an accurate record of sampling each time was well documented.

Selection of soil samplers is dependant on many factors, such as the type of sample, sample size requirements, suitability for sampling various soil types, maximum sampling depth, etc. (ASTM D 4700). A detailed soil sampling plan (for surface soil sampling and subsurface soil sampling) is given by EPA SOP 2012.

Samples for volatile or organics analysis were collected first to minimize potential loss of volatiles. The sampling methods used were ASTM D 4547 and D 6418. To minimize the potential for cross-contamination, dedicated stainless steel trowels were used at each location. Between each use, sampling equipment was decontaminated in accordance with EPA SOP 8.

2.1.3.2 Groundwater Field Sampling

Three kinds of groundwater were sampled, surface water, underground river water, and cave water. The purpose of sampling is to obtain representative water from its sources. The most critical factors necessary to achieve this are points of sampling, time of sampling and frequency of sampling. The method of sampling used is described in ASTM D 3370.

2.1.3.3 Plant Sampling

Plants are not homogeneous in their nutrient element make-up since they have leaves, stems, petioles, etc., as well as similar plant parts at different locations in the plant will differ in composition. In order to analyze the carbon content in the plant, whole sets of the plants should be sampled. The energy value of crop residues can also be measured directly using a bomb calorimeter.

2.1.3.4 Air Sampling

Ammonium bicarbonate is a relatively unstable fertilizer. Depending on temperature, soil pH, moisture and other factors, it is possible it may decompose into NH_3 and CO_2 . As illustrated by the reaction represented by the equations:



The purpose of air sampling is to test the CO_2 and NH_3 release rates from soil and fertilizer decomposition to investigate the carbon balance and ammonium fertilizer efficiency. After ABC fertilizer is applied to soil, the volatilized CO_2 is most likely taken up by plant leaves. However, there may be a small amount of CO_2 emitted into the air. In addition, there is the CO_2 released from soil organic matter decomposition, and both types of released CO_2 should be collected and trapped by chemicals, such as NaOH. By analyzing carbonate in solution, the released CO_2 can be determined.

2.2 Analytical Methods

2.2.1 Experimental Protocols

The purpose of this research is to determine the carbon balance in an ecosystem after ammonium bicarbonate fertilizer is applied to the system. A method to follow carbon throughout the ecosystem is to use a carbon tracer, which will function as a carbon indicator to track the

pathway of carbon movement. As long as ABC is applied to the soil, carbon will move throughout the ecosystem. Depending on soil pH, moisture and other properties, a portion of bicarbonate decomposes and release some CO_2 into the air. The remaining carbon will dissolve to form HCO_3^- , and move down with soil moisture where it may react with calcium or magnesium ions from soil colloids, to form bicarbonate or carbonate salts (depending on soil pH). Unreacted HCO_3^- will keep moving down into the groundwater. Groundwater contains a lot of calcium and magnesium ions, which may react with bicarbonate to form calcium carbonate and magnesium carbonate, which are stable chemical compounds. By the formation of calcium carbonate or magnesium carbonate, carbon from fertilizer will be permanently stored in the soil or under groundwater. Carbon content at each part of the ecosystem, i.e., plant, soil and groundwater will be determined individually to indicate the carbon fixation rate in plant, soil (both organic and inorganic formation) and groundwater formation.

For investigation of carbon transformations in ecosystem, the protocol of regular ABC fertilizer with dilute ^{14}C labeled fertilizer was chosen. The use of substrates labeled with C-14 will make it possible to follow the NH_4HCO_3 fertilizer behavior, such as decomposition, uptake by the plant, mixing with waters and all possible chemical reactions along its pathway. By following the movement of ABC as a fertilizer, an ecosystem was constructed containing soils and groundwater with temperature control, biomass and atmosphere with temperature control, moisture, pH and composite control. The tests focused on the carbon differences enhanced by the utilization of ABC or LEABC. Two parallel setups were used to develop the test protocol. Setups 1 and 2 used ABC and LEABC as fertilizers. The effect of ABC and LEABC on carbon sequestration was compared.

Three soils representing major farming areas and three underground waters with different compositions were selected for experiments in this work. During the experiment, the evolved CO_2 was trapped by alkali solution, and assayed for C-14 content. Soil, whole plants, and groundwater were also be sampled. Since the specific activity of C-14 in the substrate is known, the evolved CO_2 and the portioning of carbon in soils, plants and groundwater were determined.

2.2.2 Instruments for C-14 Detection and Preparation of C-14-labeled NH_4HCO_3

^{14}C is a weak β -emitter and has a half-life of about 5730 years. Like other radioactive tracers, quantitative determination is based on the ionization or excitation of matter by emitted radiation. In early work, assays were done using equipment designed for ionization of gases, for which the Geiger-Muller tube was developed. A scintillation counter is now widely used, which measures the emission of light resulting from interaction of ionizing radiation with a fluorescent substance. The Tri-Carb liquid scintillation counter was used to detect ^{14}C radiation in this project. The Tri-Carb 3100TR liquid scintillation counter is a computer-controlled benchtop liquid scintillation analyzer for detecting small amounts of alpha, beta and gamma radioactivity. The lower limit for detecting C-14 is around 5-10 DPM/sample or 2×10^{-6} microcuries/sample.

The research group is licensed to use C-14 up to 100 millicuries (mCi) once. Based on this limitation, an estimated lower carbon concentration of each part and the corresponding instrument availability was calculated.

Methods of making labeled fertilizer, $\text{NH}_4^{14}\text{CO}_3$, in laboratory are described here. C-14 labeled sodium bicarbonate was reacted with sulfuric acid in a closed system. As a result, the labeled carbon dioxide is liberated from the solution.

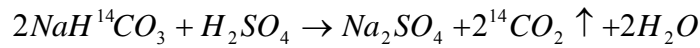

The released CO₂ is collected and pumped into a NH₄H¹⁴CO₃ synthesis system, where CO₂ will react with the ammonium and water vapor according to the reaction:

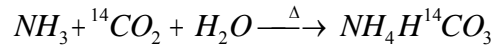

2.2.3 Analytical Procedures

2.2.3.1. Soil Analysis

Upon arrival at the lab a laboratory number is assigned to the soil sample. It is air dried in an ambient air circulating cabinet for soil drying. The minimum mass of moist material selected to be representative of the total sample is decided by particle size. The time required to bring a soil sample to an air-dried condition is determined as a function of moisture, texture, and organic matter contents. The procedure for the soil moisture test is ASTM D 2216. Soil particle size analysis is described in ASTM D 422 and D 421.

In the carbon sequestration system, the determination of bulk density is critical. It is used to evaluate total water storage capacity per soil volume, to determine if the soil layers are too compacted to allow root penetration or to provide adequate aeration. Measurement of bulk density is accomplished by taking an undisturbed block of soil (clod or soil core), determining its volume, drying it and weighing it. The formula for bulk density (ρ_B) is as follows [21]:

$$\rho_B = \frac{\text{dry soil mass}}{\text{soil volume}}$$

Pore spaces in a soil consist of that portion of the soil volume not occupied by minerals or organic solids. When soil cores are taken by a metal cylinder, the exact volume is determined by measuring the cylinder volume.

The soil pH significantly affects plant growth, primarily due to the change in availability of both the essential elements, such as phosphorus (P) and most of the micronutrients, copper (Cu), iron (Fe), manganese (Mn), molybdenum (Mo), and zinc (Zn), as well as nonessential elements, such as aluminum (Al), that can be toxic to plants at elevated concentrations [22]. The activities of microbial populations are also affected by pH as well as the activities of some types of pest chemicals applied to soils. To ensure uniform soil conditions in the experiment, alkaline and acidic soil used in this work are obtained by adding CaO and sulfur powder to neutral soil. The activities of Ca²⁺ and Mg²⁺ are particularly important in this project. As soil pH increases, the activities of Ca²⁺ and Mg²⁺ increase significantly, this increases the potential of carbon fixation. Thus alkaline soils will be more favorable to our application.

Rapid and accurate measurement of carbon in soil samples is essential for the evaluation of the amount of carbon that can be sequestered in soils. The total carbon in soils includes two parts: inorganic carbon and organic carbon. Organic carbon is present in the soil organic matter fraction, whereas inorganic carbon is largely found in carbonate minerals. The organic carbon is predominantly folic acid, microbial carbon, roots and exudates. Not all soils contain inorganic

carbon because of dissolution of carbonate minerals originally present in parent material during soil formation. Organic carbon, on the other hand, exists in all agricultural soils. Organic carbon in soil may be obtained as the difference between total carbon and inorganic carbon.

There are different methods to measure total soil carbon. High temperature combustion is one of the most popular methods and was used in this work. The sample is burned at 950°C in a stream of purified O₂. The CO₂ present in the effluent gas stream is determined by the amount of infrared radiation it absorbs. The instrument is first calibrated using Standard Reference Materials (SRMs) from the National Institute for Science and Technology (NIST).

Inorganic carbon was determined by mixing the sample with a strong acid and determining the CO₂ released by measuring the infrared radiation it absorbs. An NIST SRM is used to calibrate the instrument before use. Organic carbon was determined by the difference between the total carbon and inorganic carbon in the soil. The research group had access to automated instrumentation from LECO Corporation (St. Joseph, MI) to perform both the total carbon and inorganic carbon determination, using ASTM Method D 6316.

Carbonates have an important influence on the performance of soils in which they are present because of their relatively high solubility, as well as their alkalinity and pH buffering properties. They also play a significant role in the carbon cycle. Inorganic carbonate in soil occurs predominantly as the sparingly soluble alkaline-earth carbonates, calcite (CaCO₃) and dolomite (CaMg(CO₃)₂). Sodium carbonate and magnesium carbonate are common in evaporates or in regions of high-salt deposition in soil. The concentration of dissolved carbonate is controlled by equilibrium relations of the solid-phase carbonates and gas-phase CO₂. The concentration of dissolved carbonate is likely to be higher in systems with high partial pressures of CO₂, e.g. in flooded soils or in microenvironments of high solubility of Na₂CO₃. Also, calcite and dolomite usually control the activities of Ca²⁺ and Mg²⁺ in soils containing these minerals. If the soil has a high carbonate content, it provides less opportunity for fertilizer to capture Ca²⁺ or Mg²⁺ and form stable CaCO₃, MgCO₃.

Carbonate carbon is determined by treating a dried soil specimen with hydrochloric acid in an enclosed reactor vessel. The CO₂ gas evolved will be determined by the measuring the infrared radiation it adsorbs. An NIST RSM is used to calibrate the instrument before use. The research group has access to LECO instrumentation (LECO CHN-2000 with Carbonate Attachment) for this determination using ASTM Method D 6316.

Magnesium and calcium are abundant elements in soil and also are among the most commonly analyzed, because they are essential elements for plant growth. Calcium is essential for membrane permeability, solute transport and maintenance of cell integrity. Magnesium is required for many cellular functions including production of chlorophyll, protein synthesis, regulation of cellular pH and cation-anion balance. In this application, however, magnesium and calcium will play another important role. If there are abundant amounts of Ca and Mg in soil extracts, stable carbonate will possibly be formed and stored in soil layers.

A rapid and simultaneous procedure for the quantitative determination of Ca and Mg in soil extracts was used. Total analysis of these elements generally requires a soil digestion for complete destruction of the crystalline and organic components of the soil. The most common method is fusion with lithium tetraborate or sodium carbonate fusion, dissolution of the fused

product in acid and determining calcium and magnesium using an Inductively Coupled Plasma-Atomic Emission Spectrometer (ICP-AES) or Atomic Absorption Spectrometer (AAS).

One sample preparation system (Model 307 Perkin Elmer Sample Oxidizer) was used for ^{14}C samples. Automatic operation produces consistently reproducible, high quality samples for analysis. This technique, particularly in the case of “difficult” samples (e.g. $^3\text{H}/^{14}\text{C}$ dual label), gives better results than those associated with traditional methods. Solid samples such as soil and plants are burned conveniently and the $^{14}\text{CO}_2$ can be trapped in solution for Liquid Scintillation Counter (LSC) analysis.

2.2.3.2 Plant Analysis

Plants are not homogeneous in their nutrient element make-up since leaves, stems, petioles, and similar plant parts from different locations in the plant may have different nutrient compositions. For testing in the biological and agricultural fields, plants are separated into leaves, stems, and roots, and so on. Each part needs to be analyzed individually. Because only information on total carbon is needed in our application, the whole plant was taken for carbon evaluation.

The time of sampling must correspond to the best relationship that exists between the nutrient element concentration and the physical appearance of the plant. Based on the plant physical appearance and economic analysis of the test system (test cell is limited), plants were allowed to grow in the unit cell for 2 months (actually 50 days). After the two-month period, whole plants were taken from the closed test system and brought to the laboratory for carbon analysis.

After ^{14}C labeled ammonium bicarbonate fertilizer was applied to the soil, ^{14}C is brought into the ecosystem. Following the bicarbonate decomposition, $^{14}\text{CO}_2$ could exist in soil pores. Some was released into air above the soil surface, and participated in the photosynthesis process of the plant to form organic matter and plant tissue.

Similar to the soil ^{14}C test, ^{14}C test for plants includes carbon digestion, combustion, collection, conversion, purification, storage and counterung. The oxidizer and liquid scintillation counter is used to perform these tests.

2.2.3.3 Air Analysis

The analysis of air includes air sampling practices and trapped solution analysis. Referring to the EPA method, air was sampled from unit cell for gas analysis. CO_2 -trap solutions were sampled and analyzed for ^{14}C .

2.2.3.4 Groundwater Analysis

Total and organic carbon in water were determined by high temperature oxidation followed by coulometric titration. In the reaction zone the heat, oxidation catalyst and oxygen atmosphere convert carbonaceous matter to CO_2 . The CO_2 is determined by automatic coulometric titration. Organic carbon is determined by difference between the total carbon and the inorganic carbon. It can also be determined separately by acidifying a portion of the sample to a pH of 2 or less and

sparging with CO₂-free gas to remove carbonates, bicarbonates, and dissolved CO₂ prior to total carbon determination. The test procedure for total carbon and organic carbon is given in ASTM D 4129. Sample collection and sampling practices are given in ASTM Methods D 3370 and D 3856.

Organic carbon was also determined using a carbonaceous analyzer according to the Environmental Protection Agency (EPA) method 9060. It is used to determine the concentration of organic carbon in ground water, surface and saline waters.

It should be noted that the all pH test results in the laboratory are different from the real values for the groundwater due to the influence of pressure. CO₂ in surface waters generally contain less than 10 mg/L, except at local points of abnormal organic or mineral decomposition. However, underground water, particularly deep waters, may contain several hundred mg/L. The results from laboratory tests have to be calibrated before they can represent the real conditions. The test procedure used is given in ASTM Method D 1293 or EPA test method 9040B.

Ca and Mg contents are very important for this work. Higher Ca and Mg concentrations provide increased opportunities for bicarbonate or carbonate to react and form slightly soluble carbonates. The Ca and Mg in water were determined by Inductively Coupled Plasma-Atomic Emission Spectroscopy (ICP-AES). The test procedures are given in ASTM D 511.

Hardness is normally expressed as the total concentration of Ca²⁺ and Mg²⁺ in milligrams per liter equivalent CaCO₃. It was determined by substituting the concentration of Ca²⁺ and Mg²⁺, expressed in milligrams per liter, in the expression:

$$\text{Total Hardness} = 2.5 \times [\text{Ca}^{2+}] + 4.1 \times [\text{Mg}^{2+}]$$

Hardness can be developed as a parameter to evaluate the ability of groundwater carbon fixation. Groundwater hardness test is given in ASTM 1126.

A summary of all analytical methods used in the project is given in Table 1.

Table 1. Summary of Analytical Methods Used in the Project

Analysis	Test Method & Standards
Soil	
Soil moisture	ASTM D 2216
Soil bulk density	Ref [18]
Soil pH	SSSA method, ASTM D 4972
Soil volatile test	ASTM D 3694
Soil particle size	ASTM D 422, D 421
Soil total Carbon	SSSA method
Soil organic Carbon	SSSA method,
Soil carbonate Test	ASTM D 4373,
Soil Ca and Mg	SSSA method
Groundwater	
Groundwater pH	ASTM D 1293, EPA 9040
Groundwater Total Carbon	ASTM D 4129
Groundwater Organic Carbon	ASTM D 4129, EPA-9060
Water standardization for chemical analysis	ASTM E 200
Ca and Mg in water	ASTM D 511
Groundwater hardness	ASTM 1126
Plant carbon	ASTM D 4638, SSSA
Air carbon (trapped in solution)	ASTM D 4129

3. Results and discussion

3.1. Local Rainfall/Snow Collection and Analysis

In order to simulate the real ecosystem conditions and determine irrigation amounts needed for this work, rainfall and snow were collected in the Bowling Green, KY, area and analyzed in the laboratory. Cation analysis was done by inductively coupled plasma-atomic emission spectroscopy, anion analysis was completed using ion chromatography and the pH of the samples was measured with a digital pH meter. The test results are listed in Table 2. It should be noted that the rainfall or snow are all acidic. Rain or snow is not a significant source for Ca or Mg ions, but does influence soil pH to some degree depending on the rainfall amount and frequency. The soil pH directly influences the Ca and Mg activity in the soil.

Table 2. Elemental Composition and pH of Rain and Snow (mg/L)

Samples	K, ppm	Na, ppm	Ca, ppm	Mg, ppm	Cl, ppm	pH
Rainwater 1	0.53	9.60	1.9	1.37	7.87	5.98
Rainwater 2	<0.32	13.52	2.78	<0.01	12.58	5.90
Rainwater 3	0.64	3.90	1.64	0.16	2.92	5.05
Rainwater 4	1.69	12.9	1.5	0.347	13.2	5.64
Snow 1	0.42	3.69	2.29	0.14	4.12	5.53

Simulated rain will be used as part of the irrigation water. The amount and frequency of irrigation is determined based on yearly rainfall average in the local region.

3.2. Soil Properties

Soil samples were collected from the Western Kentucky University farm and analyzed as follows:

Table 3. Summary of Measured Values of Soils

	Average	Unit	Test method
Soil bulk density test	1460	Kg/m ³	
Soil moisture	15.8	%	ASTM D 2216
Soil pH	7.06	-	ASSS 11.10
Soil total carbon	10.35	%	ASTM D 5373
Soil inorganic carbon	0.018	%	SSSA-5- Chap.34
Soil Ca ²⁺	857	Ppm	AAS
Soil Mg ²⁺	1238	Ppm	AAS

3.3. Groundwater Properties

Groundwater samples were collected from the Mammoth Cave National Park and analyzed. The measured values are as follows:

Table 4. Summary of Test Results for Groundwater

Items	Logdon Underground River	Echo Spring Water	Green River
Sampling location	Mammoth Cave	Mammoth Cave	Mammoth Cave
Depth (ft)	350	0	Surface water
pH	7.74	7.51	7.77
Na ⁺ (ppm)	11.3	6.83	11.2
Mg ²⁺ (ppm)	9.72	6.47	10.8
Ca ²⁺ (ppm)	60	46.2	46.3
K ⁺ (ppm)	0.467	1.67	4.75
Cl ⁻ (ppm)	12.2	5.98	12.6

3.4. Fertilizer Leaching Test

The purpose of this experiment is to determine the percentage of the additional contribution to carbon fixation that occurs from the ammonium fertilizer application. Two parallel experiments were conducted. Setup-1 was used to test de-ionized water infiltration (the operating procedure is the same as infiltration experiment), while the other setup (Setup-2) tested ABC solution infiltration. After ABC is applied to the soil, NH₄⁺ or HCO₃⁻ could infiltrate with moving water, and react with materials in the soil. By testing Ca²⁺ and Mg²⁺ concentrations in the percolate, it is possible to know the portion of Ca and Mg that is fixed in the soil by the ABC application. It could be inferred that the concentrations of these ions in the percolate are a measure of how much the carbon dioxide is stored in the soil by ABC utilization only. Tests were done in both Columns A and B. The operating conditions used are listed in Table 5.

Table 5. Operating Conditions for Fertilizing Leaching Tests

	Column A		Column B	
	Water	ABC Solution	Water	ABC Solution
Add in (mL)	1800	1800	3400	3400
percolate (mL)	862	844	1642	1414
Ca (ppm)	106	17.1	64.2	23.1
Mg(ppm)	9.6	3.27	7.31	3.61

Figure 5 shows that the infiltration rate for water alone is much faster than the infiltration rate of the ABC solution under the same operating conditions. This implies

that the chemicals in ABC may change soil pore structure, resulting in longer infiltration times. The Ca^{2+} and Mg^{2+} are no longer in solution, they do not counteract the effects of Na^+ and problems related to high exchangeable sodium percentages may occur. This results in an increase in soil pH and a corresponding decrease in water quality and soil infiltration. CaCO_3 and MgCO_3 may coagulate and block some of the soil pores, which may cause infiltration to become slower. As the water moves down, Ca^{2+} and Mg^{2+} may be captured and stored in the soil, H^+ is then released into the water or solution. Therefore, the percolate shows an increased acidity, which causes the reaction to become slower. The infiltration time is increased exponentially as the added water amount becomes larger.

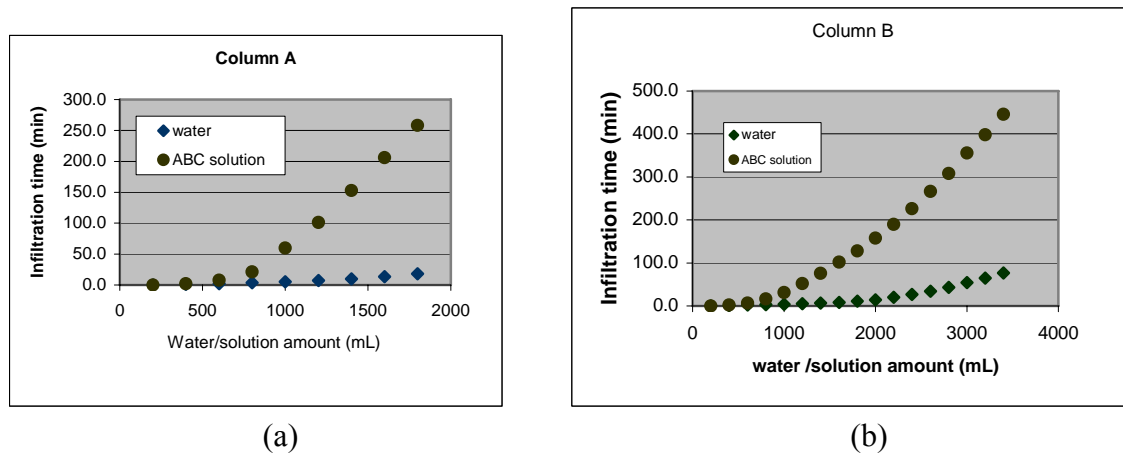

Figure 5. Comparison of water infiltration and ABC solution infiltration.

Upon testing the leached Ca and Mg contents in the percolates, a portion of the Ca^{2+} and Mg^{2+} appears to remain in the soil following the ABC application. In other words, carbon could be fixed in soil in the form of calcium carbonate or magnesium carbonate. The same amount of water and ABC solution were added to the soil columns, and similar amounts of percolated water were collected in the bottom of the soil columns. However, the Ca and Mg concentrations are very different, as shown in Figure 6.

Compared to water infiltration, only a small amount of Ca and Mg was leached from the column when the ABC solution was used, indicating Ca and Mg have been fixed in the soil. The fixing rate of Ca^{2+} and Mg^{2+} in Column A is 2608 g/inch soil, while it is 1233g/inch soil in Column B, which indicates that the fixing rate will be gradually reduced with the infiltration depth.

The ABC infiltration test gives a quick look at the soil structure. It shows that soil itself has a great ability to fix carbon in the form of stable carbonates, and to reduce the rate of irrigation water and fertilizer infiltration, which is beneficial for agriculture applications.

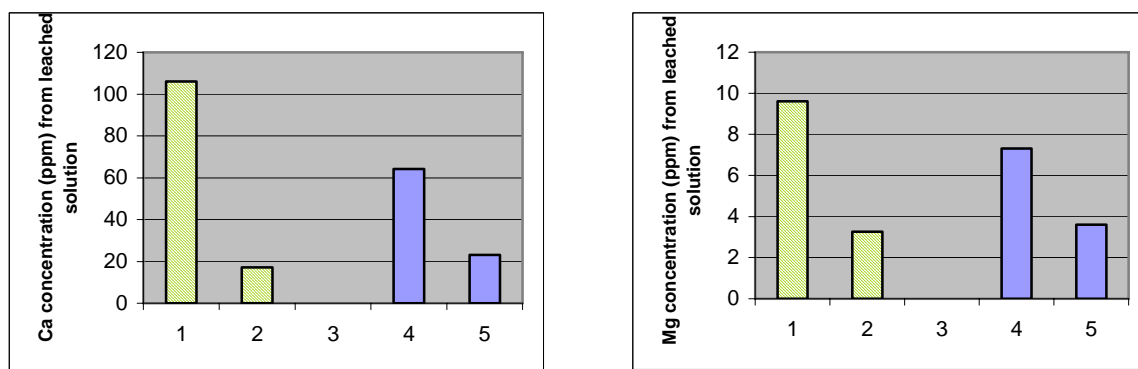

Figure 6. Comparison of Ca and Mg concentrations in percolated water; (a) Ca concentration from leached solution, (b) Mg concentration from leached solution; 1-Column A, using water infiltration; 2-Column A, using ABC solution infiltration; 3-Column B, using water infiltration; 4-Column B, using ABC solution infiltration; 5-Column B, using ABC solution infiltration.

3.5 Synthesis of $NH_4H^{14}CO_3$ and Long-Term Effect $NH_4H^{14}CO_3$ fertilizer

Although the aqueous ammonia scrubbing process is an attractive way to capture low concentrations of CO_2 from flue gas, chemical reactions among CO_2 , ammonium and H_2O are very complex and poorly understood - many species co-exist in the solution in an unstable transition. These species could include, but are not limited to, ammonium bicarbonate, ammonium carbonate, and ammonium carbamate (all in crystalline and aqueous solution forms), plus CO_2 , NH_3 , and NH_4OH . Previous work [23] in the research group used various analytical techniques to determine ABC in the products of a bench-scale aqueous ammonia CO_2 scrubbing system. Fourier transform infrared spectroscopy (FT-IR) and X-ray diffraction (XRD) were used to qualitatively distinguish ABC from ammonia carbonate (ACN) and ammonia carbamate (ACM). CHN elemental analysis and Near-IR spectroscopy were used to quantify the ABC and show that an acoustooptical tunable filter (AOTF)-based Near-IR spectrometer is an ideal tool for on-line measurement of ABC. The principle reason for the success of the Near-IR spectrometer is that this technology allows for fast scanning with no moving parts and there is no need recalibrate the system. Current work has its unique characteristics and it is unsafe and non-economical to do all analysis for ^{14}C tagged products. Instead, an exact replica of the same system as shown in Figure 7 was built in parallel to do synthesis work with regular $NaHCO_3$ (not $NaH^{14}CO_3$). In this way the products can be analyzed as described in reference [23].

The synthesis process is performed under initial conditions of ambient pressure and room temperature and the procedure shown in Figure 7 is followed. It was found that the CO_2 concentration changes from 0% to be saturated. The solubility of CO_2 in water is 1:0.4 (1.45%) and the solubility of NH_3 is 1:702 (34%). The possible carbonates in solution are NH_4HCO_3 , $NH_4HCO_3 + (NH_4)_2CO_3 \cdot H_2O$ or $NH_2COONH_4 + NH_3$ (see Figure 8, the NH_3 - CO_2 - H_2O phase diagram). Table 6 summarizes the analytical results of

five synthesized samples (ABC or LEABC) and three standard samples. Four samples were synthesized at ambient pressure and one was synthesized at 5 lbs/in². Elemental analysis (C, H, & N) of all five samples was done. The amounts of nitrogen in all synthesized samples (ID's 4-8) were under 20%, which indicates the main component is NH₄HCO₃. The carbon concentrations for all samples are under 15% and the hydrogen concentrations for four samples are over 6.42%, which indicates more water is contained in these samples. As was shown in reference [23], the majority of the components were ABC.

It was found that the recovery rate of ¹⁴C depends on the amount of NaHCO₃ added and flowrate of H₂SO₄ added. The more regular NaHCO₃ is added in flask B₁ and the slower the H₂SO₄ is added, the higher the recovery rate will be. The recovery rates are shown in Table 7.

Table 6. Summary of CHN Elemental Analysis for Synthesized Samples and Standard Samples.

ID	Sample	Pressure (gauge pressure)	Measured results			Calculated results		
			C (%)	H (%)	N (%)	C (%)	H (%)	N (%)
1	Standard sample (NH ₄) ₂ CO ₃	-	15.46	7.51	30.41	12.50	8.39	29.16
2	Standard sample NH ₄ HCO ₃	-	15.13	6.42	17.46	15.19	6.37	17.72
3	Standard sample NH ₂ CO ₂ NH ₄	-	15.42	7.91	35.82	15.38	7.75	35.89
4	Synthesized ABC	0	11.28	6.77	17.25	-	-	-
5	Synthesized ABC	0	10.46	8.18	18.09	-	-	-
6	Synthesized ABC	5 lbs/in ²	12.11	7.29	18.99	-	-	-
7	Synthesized LEABC	0	12.28	6.98	16.40	-	-	-
8	Synthesized LEABC	0	14.02	6.35	16.69	-	-	-

Table 7. Summary of ¹⁴C recovery rate during synthesis process

Synthesized products	Input ¹⁴ C activity mCi	Recovered ¹⁴ C activity mCi	Recovery rate (%)
ABC	25.00	23.08	92.3
LEABC	25.00	17.55	70.2
ABC	25.00	24.09	96.3
LEABC	25.00	24.10	96.4

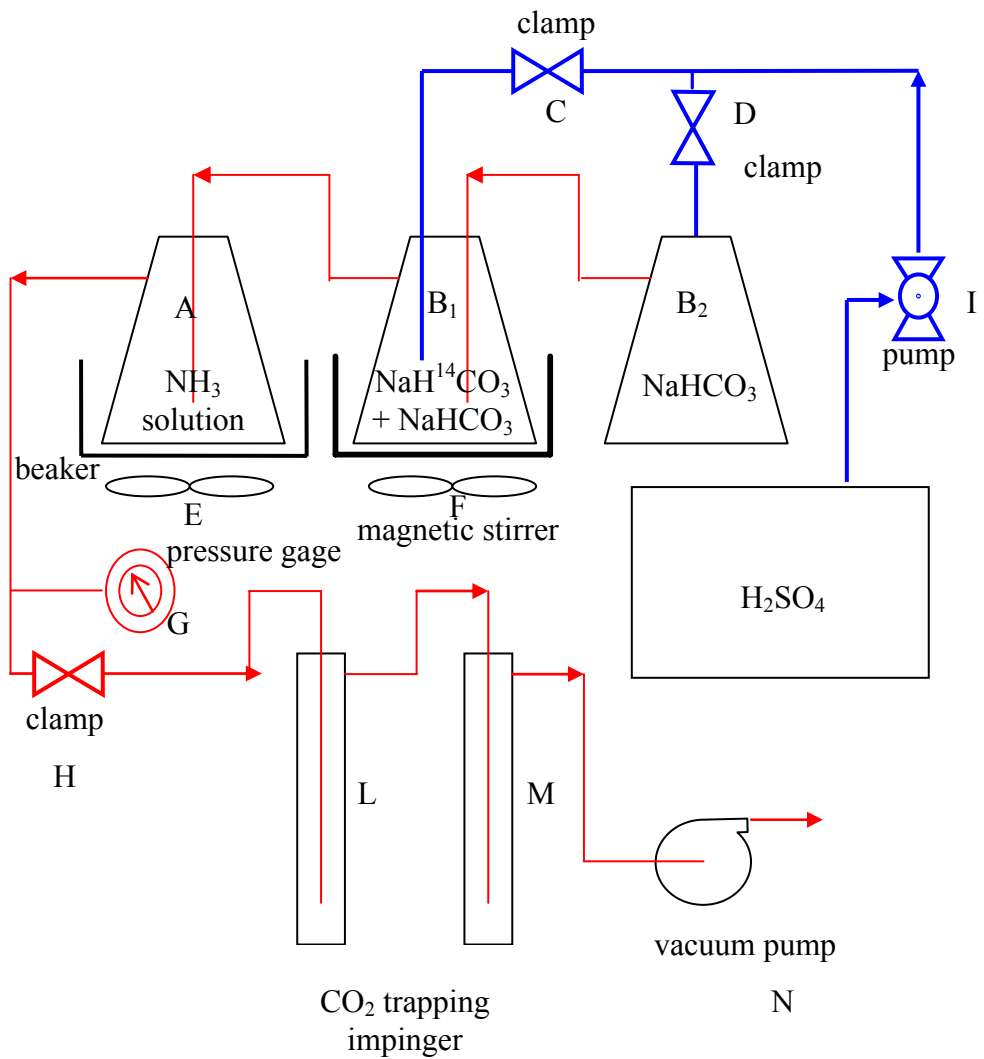

Figure 7. A schematic of the $\text{NH}_4\text{H}^{14}\text{CO}_3$ synthesis process.

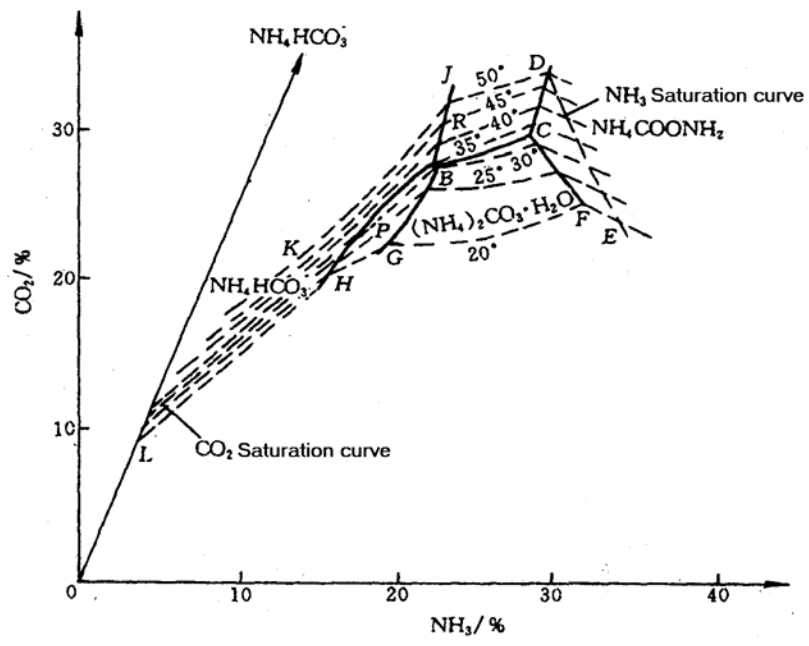

Figure 8. Gu-Pis phase diagram of $\text{NH}_3\text{-CO}_2\text{-H}_2\text{O}$ system

3.6 Carbon Distribution

Wheat was seeded in 18 unit growth cells. Each cell represents a unique growth condition which is combined by soils or underground water or fertilizer. Table 8 summarizes various experimental conditions for this work. There are one type of plant (wheat), two types of fertilizer (ABC, LEABC), three types of soil (pH value less than 7, equal to 7 and greater than 7) and three kinds of groundwater (from Echo Spring, Green River Water and Hawkins River). The cross sections of six triple-growth cells are given in Figure 9 to see the detail of the combination for experimental conditions. After a 50 day growth period, the plants were harvested. Then soil, groundwater, plant and air samples were handled for radioactive analysis by LSC. The measured ^{14}C distribution should directly represent the carbon fate from fertilizer, as reported in references [24-25]. The comprehensive experimental results for ^{14}C distribution are listed in Table 9.

Table 8. Summary of Experimental Conditions

Growth chamber ID	Plant	Fertilizer	Soil pH Value	Water source
A-1	Wheat	ABC	>7	Echo Spring
A-2			>7	Green River
A-3			>7	Hawkins River
B-1			<7	Echo Spring
B-2			<7	Green River
B-3			<7	Hawkins River
C-1			=7	Echo Spring
C-2			=7	Green River
C-3			=7	Hawkins River
D-1		LEABC	>7	Echo Spring
D-2			>7	Green River
D-3			>7	Hawkins River
E-1			<7	Echo Spring
E-2			<7	Green River
E-3			<7	Hawkins River
F-1			=7	Echo Spring
F-2			=7	Green River
F-3			=7	Hawkins River

3.6.1 Carbon Stored in Soil

Trapped carbon in soil portion varied from 38.21% to 77.29% among the 18 growth cells. For alkaline soil, there are high percentages of carbon trapped in the soil, for example, 75% (ABC) and 76.06% (LEABC). It was found that there was only a slight difference (about 1%) in trapped carbon percentage between the test using the two types of fertilizer (ABC and LEABC). For the same type soil, percentages of trapped carbon are close to each other even though there is a different fertilizer or a different groundwater. However, there are exceptions, for example the cell ID A-3 (alkaline soil, ABC, Hawkins River water) and D-2 (alkaline soil, LEABC, Green River water). It is concluded that soil pH

value affects carbon capture significantly. Alkaline soil has higher capture percentage (up to 75%), neutral soil has the second highest capture percentage, and the acidic soil has the lowest capture percentage. HCO_3^- is captured more easily in weakly alkaline conditions.

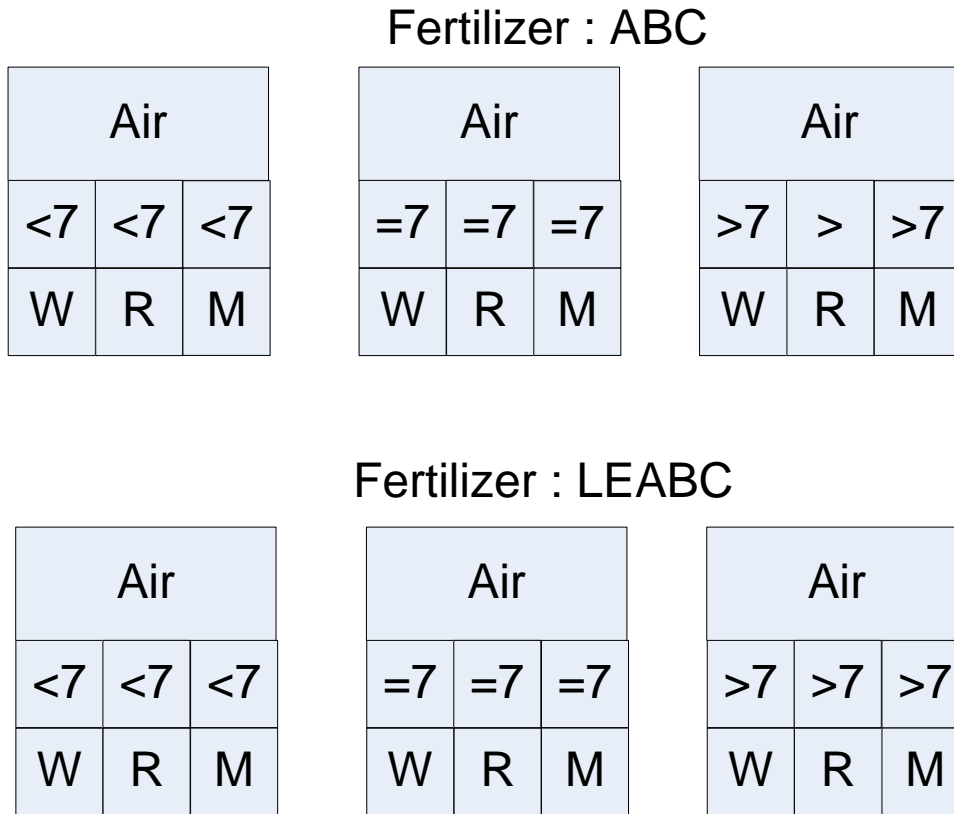

Figure 9. Cross sections schematics of six triple-growth chambers (W: Echo Spring water; R: Green River water; M: Hawkins River water).

3.6.2 Carbon Stored in Plants

The carbon from fertilizer is assimilated into plants through the photosynthesis process or root breathing process. About 10% of the carbon from fertilizer was eventually stored in wheat. The stored carbon percentage varies from 3.07% to 11.38%. Wheat grown in neutral soil has a trend to store more carbon.

3.6.3 Carbon Stored in Underground Water

Very little carbon from fertilizer percolated down to be stored in groundwater. The percentage varied from 0.64% (ID F-2, LEABC, pH = 7, Green River water) to 4.74%

(ID A-1, ABC, pH>7, Echo Spring water). No difference in carbon capture was seen as a function of groundwater under different experimental conditions.

3.6.4 Carbon Released into the Air or Lost

There were substantial losses for fertilizer carbon released into the air or lost during the whole growth period. The percentages are in the range of 20% - 50%. Carbon loss is worse for acidic soils with a loss percentage up to 52.01% (ABC, pH>7, Echo Spring water).

Table 9. Carbon Distribution in Soil, Plant, Groundwater and Air

Growth Chamber ID	¹⁴ C Trapped in Soil (%)	¹⁴ C Stored in Plants (%)	¹⁴ C Stored in Groundwater (%)	¹⁴ C Released to Air and Loss (%)
A-1	71.03	3.90	4.74	20.34
A-2	75.00	3.59	1.62	19.78
A-3	55.68	8.12	2.31	33.89
B-1	40.65	4.56	2.78	52.01
B-2	39.76	6.24	1.23	52.77
B-3	46.61	5.72	1.12	46.55
C-1	43.15	6.49	5.77	44.59
C-2	47.48	7.22	0.87	44.42
C-3	51.13	6.51	1.39	40.97
D-1	76.06	3.07	1.57	19.3
D-2	54.46	4.97	1.48	39.1
D-3	77.29	4.63	2.06	16.02
E-1	38.21	5.89	2.78	53.11
E-2	43.43	6.79	1.36	48.41
E-3	39.77	5.41	1.99	52.83
F-1	39.43	11.38	1.19	48
F-2	55.92	8.31	0.64	35.13
F-3	45.84	7.82	1.42	44.92

3.6.5 Different Effects of Carbon Storage Between ABC and LEABC

Different fertilizer (ABC or LEABC) effects on carbon storage can be observed based on the comparison for grouped samples. As shown in Table 9, sample groups A-1 and D-1 only have different fertilizers, but have the same plant, groundwater and soil. For group A-1, 71.03% ABC fertilizer carbon is stored in the soil. For group D-1, 76.06% LEABC fertilizer carbon is stored in the soil. There is only a 5% difference for the fertilizer carbon storage in soil. Similarly, when considering plants, there is less than a 1% difference for fertilizer carbon storage, and less than a 3% difference for fertilizer carbon storage when considering groundwater sources. The comparison for the rest of the

groups leads to very similar conclusions, that is, ABC and LEABC themselves do not show an obvious difference in effects of fertilizer for carbon storage, even though there is an advantage for LEABC since it is more stable.

3.6.6 Carbon Storage Effects among Different Soils

Different soil pH values have completely different capabilities for storing fertilizer carbon. As shown in Table 9, comparisons of carbon distribution among groups A, B and C or D, E, and F indicate that alkaline soils have the highest capability for storing carbon in soils, neutral soils and acidic soils have similar capabilities for carbon storage when considering experimental uncertainties. This can be explained by the fact that HCO_3^{3-} tends to combine with Ca^{2+} and Mg^{2+} in weak alkaline conditions.

3.7 Carbon Forms Existing in Soil and Calcium Availability

As mentioned earlier, a higher percentage of carbon from fertilizer is captured in the soil. What kind of carbon forms exist in the soil? After the fertilizer ABC or LEABC is applied to soil, carbon in soil can go in four directions: air, plant, soil and water or ground water, as shown in Figure 9. Fertilizer carbon enters the soil by two different ways, residues directly from the fertilizer or through photosynthesis and growth of roots from decomposed CO_2 from fertilizer. As shown in Figure 9, soil is a very important pool and fertilizer carbon exists in two forms, organic carbon and inorganic carbon. Organic matter in soil can be classified into macromolecule organic matter, carbohydrate, fat and protein etc, and low molecular weight organic matter. Inorganic carbon includes insoluble carbonate, hydrocarbonate and insoluble carbonate. After ^{14}C tagged ABC or LEABC is applied to soil over 50 days, it could be classified into three groups by washout with DI water and acid, as shown in Figure 8. The important operation parameters for this washout process are time and acid concentration. Long washing times and high acid concentrations can cause macromolecules to hydrolyze to small molecule organic matter. In this work, washing time is over one hour and HCl concentration is 0.5 N (soil used for the experiment has relative high carbonate content).

Six representative post-experiment soil samples were selected to perform carbon form experiments. The results are listed in Table 10. It is very encouraging that up to 88% of the carbon from fertilizer exists in insoluble salts (i.e. CaCO_3) in the alkaline soil, regardless of fertilizer type ABC or LEABC. However, for acid soil, the percentage of CaCO_3 in soil is low so the level is reduced to 10% to 25%.

Table 10. ¹⁴C Forms the Exist in Soils

Fertilizer Applied	Soil Type (pH Value)	Growth Chamber ID	Dissociated Carbonate or Small Organic Molecule (%)	CaCO ₃ (%)	Macromolecule Organic Carbon (%)
ABC	<7	B-3	17.75	10.98	71.27
	=7	C-3	2.33	81.85	16.62
	>7	A-2	1.22	88.91	9.87
LEABC	<7	F-3	17.82	24.27	57.91
	=7	E-2	0.06	84.85	15.09
	>7	D-3	7.62	83.41	8.97

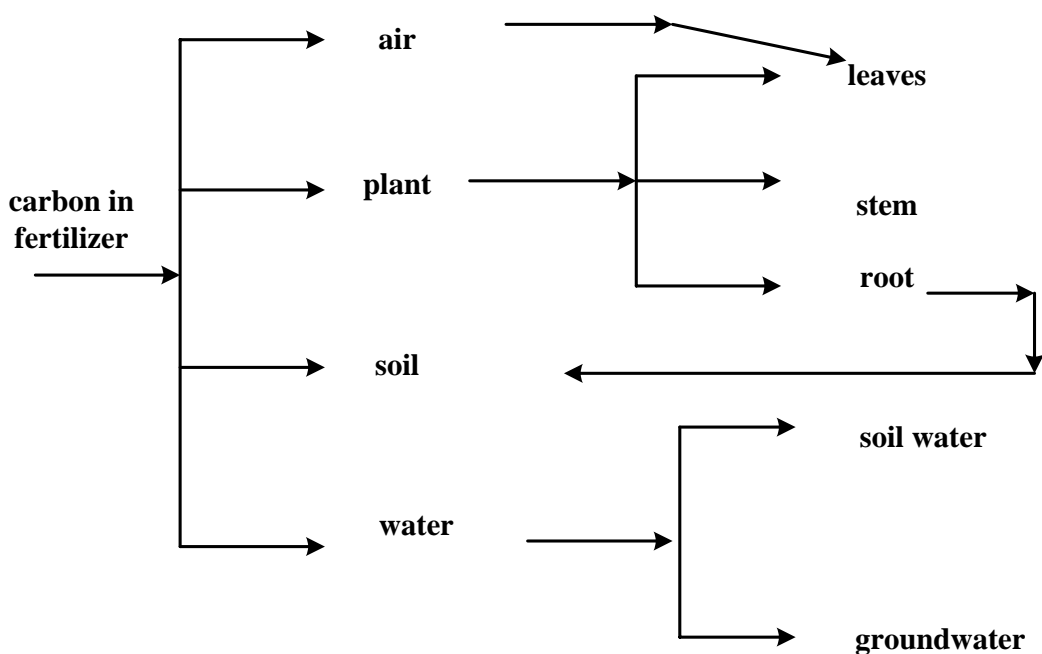

Figure 9. Fertilizer Carbon Flow Chart

As reported in Section 3.2, there is an abundance of Ca²⁺ and Mg²⁺ in the selected soil. The Ca²⁺ concentration is 857 ppm and the Mg²⁺ concentration is 1238 ppm. The availability of Ca²⁺ and Mg²⁺ in soil is a key source for storing carbon in soil.

3.8 Carbon 14 Tracer Technique

Methodology to trace carbon changes at each part of the greenhouse for evaluating a carbon balance requires carbon isotope dilution studies. Three principal isotopes of carbon occur naturally -- carbon 12 (^{12}C), carbon 13 (^{13}C) and carbon 14 (^{14}C). The mass percentage of carbon-12 is 98.89%, of carbon-13 is 1.11% and of carbon—14 is 0.0000000001%. Of these, carbon-14 is radioactive and can be used as a tracer. The limitation in determining ecosystem carbon sequestration in this study is the accuracy of the methods used to assess changes in total carbon of each portion, especially the soil and groundwater portions, because carbon entering the soil through the fertilizing process is much smaller compared to the background soil carbon. Among the three carbon isotopes, ^{14}C isotope dilution approach can overcome this problem due to its extremely low content in nature and high radioactive property. It follows the same pathway as the more abundant isotope ^{12}C .

^{14}C is not an external exposure hazard because its low-energy beta radiation will not penetrate the gloves and skin. ^{13}C is a good tracer for tracking the carbon cycle also, since it always has a consistent ratio to ^{12}C . However, its high background value required a large quantity for this research, which limited its use in the project because of its high cost.

Generally, the ^{14}C radioactive isotope technique is used in chemistry and biochemistry research to study detailed molecular structures and reaction mechanisms. In this work, this technique was successfully extended to CO_2 sequestration research involving a complex engineered ecosystem. This also can greatly contribute to other engineering technology developments and to other CO_2 sequestration research underway.

4. Conclusions

Anthropogenic CO_2 released from fossil fuel combustion is a primary greenhouse gas which contributes to “global warming.” Stationary power generation contributes over one-third of CO_2 emissions. This investigation mainly focused on the carbon distribution after a synthesized fertilizer was applied to soils. The fertilizer studied is ammonium bicarbonate, which can be produced through the capture of CO_2 by ammonia injection into power plant flue gas. ^{14}C tagged ammonium bicarbonate (ABC, NH_4HCO_3) and long-term effect ammonium bicarbonate (LEABC, NH_4HCO_3) were synthesized from $^{14}\text{CO}_2$ in the laboratory. The fertilizer (ABC or LEABC) is used as a “carrier” to transport CO_2 from the atmosphere to the crops and soil. Carbon (from fertilizer) distribution was determined by measuring ^{14}C activity in soils, plants, groundwater and air. After biological assimilation and metabolism in crops receiving ABC or LEABC, a considerable amount (up to 10%) of the carbon source is absorbed by the plants with increased biomass product. The majority of the unused carbon source (up to 76%) percolates into the soil as carbonates, such as an environmentally benign calcium carbonate (CaCO_3). The soil carbon which originally comes from fertilizer is analyzed in detail. Up to 88% of the soil carbon from fertilizer exists as insoluble carbonate, such as CaCO_3 . These findings answer the questions how carbon is distributed after synthesized fertilizer is applied into the ecosystems. In addition, a separate post-experiment on fertilizer carbon forms existing in soil was made. It was found that the up to 88% of the

trapped carbon exists in the form of insoluble salts (i.e., CaCO_3) for alkaline soil. This indicates that alkaline soil has a greater potential to store carbon after the use of the synthesized fertilizer.

5. References

1. *Report of the Conference of the Parties on Its Third Session Held at Kyoto*, Dec. 1-11, **1997**, Kyoto Protocol, FCCC/CP/1997/Add.1, United Nations, New York, NY.
2. Houghton, J. T.; Meira Filho, L. G.; Callander, B. A.; Harris, N.; Kattenberg, A.; Maskell, K., (Eds) **1996**: “*Climate Change, The Science of Climate Change*”. Cambridge University Press.
3. Dave R. et. al, Carbon Sequestration Research and Development, a report of Office of Science, Office of Fossil Energy, U.S. DOE, available on website: www.ornl.gov/carbon_sequestration, Dec. 1999.
4. Gottlicher, G. *The Energetics of Carbon Dioxide Capture in Power Plants*, U.S. Department of Energy, Office of Fossil Energy, National Energy Technology Laboratory, 2004.
5. Herzog, H.; Eliasson, B.; kaarstad, O. *Scientific American* **2000**, 282(2), 72-79.
6. Yamasaki, A. *Journal of Chemical Engineering of Japan* **2003**, 36 (4), 361-375.
7. White, C. M.; Strazisar, B. R.; Evan JJ. G.; James, S. H.; Henry, W. P. *J. Air & Waste Manage. Assoc.* **2003**, 53, 645-715.
8. Schnitzer, M. *Soil Sci.* **1991**, 151, 41-58.
9. Freund, P. “Abatement and Mitigation of Carbon Dioxide Emissions form Power Generation,” Power-gen 98 Conference, Milan, June, 1998.
10. Lee, J. W.; Li, R. *Energy Conversion & Management* **2003**, 44, 1535-1546.
11. Bai, H.; Yeh, A. C. *Ind. Eng. Chem. Res.* **1997**, 36, 2490-2493.
12. Yeh, A. C.; Bai H. *The Science of the Total Environment* **1998**, 228, 121-133.
13. Smouse, S. M.; Ekmann, J. M. “Experimental study to capture CO₂ in the flue gas from a coal-fired research facility by spraying aqueous ammonium to produce a modified NH₄HCO₃ fertilizer”, 2nd annual conference on carbon sequestration: Developing & validating the technology base to reduce carbon intensity, May 5-9, 2003, Virginia.
14. Zhang, Z. M.; Feng, Y. Q. *New Fertilizer: Long-term Effect Ammonium Bicarbonate*, Chemical Industrial Press, **1998**, Beijing, in Chinese.
15. Zhou, J.; Shang, J.; Der, V.; Li, Z.; Zhang, J.; Li, X.; Zhang, Z. “A feasibility study on a two stage benefits CO₂ sequestration Technology for fossil fuel power generation”, 1st annual conference on carbon sequestration, May 15-17, 2001, Virginia.
16. Shang, J, “Carbon sequestration by the agricultural use of ammonium bicarbonate (ABC)”
17. Smouse, S. M.; Ekmann, J., M. et al., “Experimental study to capture CO₂ in the flue gas from a coal-fired research facility by spraying aqueous ammonium to produce a modified NH₄HCO₃ fertilizer”, *Proceedings*, Second annual conference on carbon sequestration: Developing & Validating the Technology Base to Reduce Carbon Intensity, May 5-9, 2003, Virginia.
18. Solubilities in water, <http://lsd.k12.mi.us/~eastchem/soltable.html>.

19. Martin, J.H.; Leonard, W.H. and Stamp D.L. *Principles of field crop production*, Macmillan Publishing Co. Inc. 3rd edition, 1976.
20. Brady, N.C.; Weil, R.R. *The Natural Properties of Soils*, Prentice Hall, 11th edition, 1996.
21. Gardiner, D. T; Raymond, W.M., *Soil in Our Environment*, Pearson Education LTD, 2004, 10th edition.
22. Soil and plant analysis council, Inc. *Soil Analysis Handbook of Reference Methods*, CRC Press, 1999.
23. Meng, L; Burris S.; Bui, H.; Pan, W.-P. *Anal. Chem.* **2005**, 77, 5947-5952
24. Zagal, E. *Plant and Soil* **1994**, 166, 63-74.
25. Meharg, A. A; Lillham, K. *Soil Biol. Biochem* **1990**, 22 (4), 471-477.