

Lessons Learned from Case Studies of Six High-Performance Buildings

P. Torcellini, S. Pless, M. Deru, B. Griffith,
N. Long, and R. Judkoff

Technical Report
NREL/TP-550-37542
June 2006

NREL is operated by Midwest Research Institute • Battelle Contract No. DE-AC36-99-GO10337



Lessons Learned from Case Studies of Six High-Performance Buildings

P. Torcellini, S. Pless, M. Deru, B. Griffith,
N. Long, and R. Judkoff

Prepared under Task No(s). BEC31001, BEC61012

Technical Report
NREL/TP-550-37542
June 2006

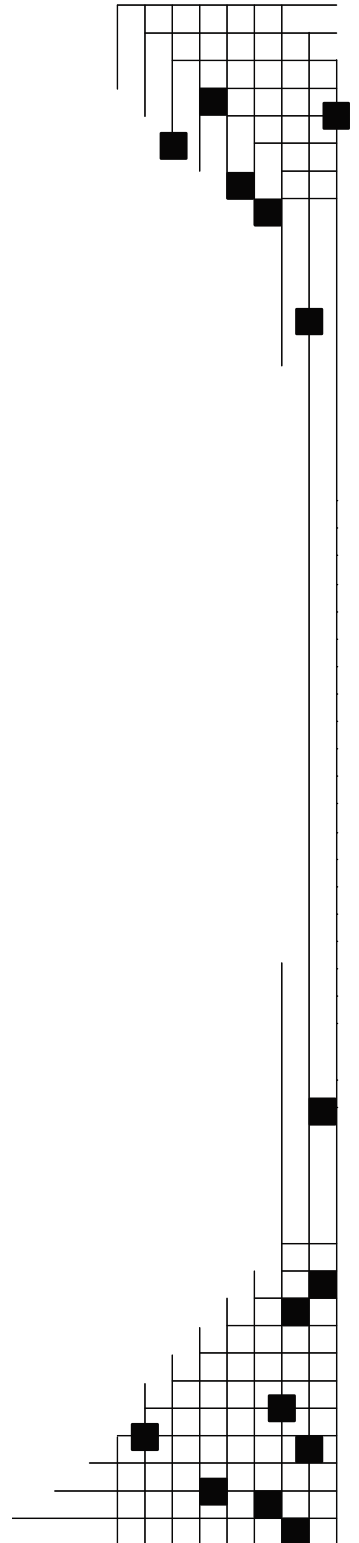

National Renewable Energy Laboratory
1617 Cole Boulevard, Golden, Colorado 80401-3393
303-275-3000 • www.nrel.gov

Operated for the U.S. Department of Energy
Office of Energy Efficiency and Renewable Energy
by Midwest Research Institute • Battelle

Contract No. DE-AC36-99-GO10337

NOTICE

This report was prepared as an account of work sponsored by an agency of the United States government. Neither the United States government nor any agency thereof, nor any of their employees, makes any warranty, express or implied, or assumes any legal liability or responsibility for the accuracy, completeness, or usefulness of any information, apparatus, product, or process disclosed, or represents that its use would not infringe privately owned rights. Reference herein to any specific commercial product, process, or service by trade name, trademark, manufacturer, or otherwise does not necessarily constitute or imply its endorsement, recommendation, or favoring by the United States government or any agency thereof. The views and opinions of authors expressed herein do not necessarily state or reflect those of the United States government or any agency thereof.

Available electronically at <http://www.osti.gov/bridge>

Available for a processing fee to U.S. Department of Energy and its contractors, in paper, from:

U.S. Department of Energy
Office of Scientific and Technical Information
P.O. Box 62
Oak Ridge, TN 37831-0062
phone: 865.576.8401
fax: 865.576.5728
email: <mailto:reports@adonis.osti.gov>

Available for sale to the public, in paper, from:

U.S. Department of Commerce
National Technical Information Service
5285 Port Royal Road
Springfield, VA 22161
phone: 800.553.6847
fax: 703.605.6900
email: orders@ntis.fedworld.gov
online ordering: <http://www.ntis.gov/ordering.htm>



CONTENTS

Acknowledgments	vi
Executive Summary	vii
Lessons Learned Summary	viii
Best Practices for High-Performance Buildings	ix
Acronyms	xii
1 Introduction	1
1.1 Problem Definition	1
1.2 Methodology	2
1.3 Goals and Objectives	3
1.4 Report Organization	3
2 Case Studies	4
2.1 Adam Joseph Lewis Center for Environmental Studies, Oberlin College	5
2.2 Zion Visitor Center	5
2.3 Cambria Office Building	6
2.4 Philip Merrill Environmental Center, Chesapeake Bay Foundation	7
2.5 Thermal Test Facility	7
2.6 BigHorn Home Improvement Center	8
2.7 Energy Performance Summary	9
3 Lessons Learned	13
3.1 Applying a Whole-Building Design Process	13
3.1.1 <i>Owners provide the main motivation for low-energy buildings</i>	15
3.1.2 <i>Setting measurable goals is crucial to achieve low-energy buildings</i>	15
3.1.3 <i>Cost justification of integrated design</i>	19
3.1.4 <i>Using energy modeling throughout process</i>	20
3.1.5 <i>Common roadblocks to successful integrated design process implementation</i>	23
3.1.6 <i>Measured versus predicted performance</i>	24
3.1.7 <i>Monitoring leads to better management and improved performance</i>	25
3.2 Lighting and Daylighting Systems	26
3.2.1 <i>Daylighting designs</i>	27
3.2.2 <i>Daylighting and lighting controls</i>	31
3.2.3 <i>Lighting energy savings</i>	33
3.2.4 <i>Six elements of successful daylighting systems</i>	37
3.3 Integrating the Envelope and Mechanical Systems	43
3.3.1 <i>HVAC system descriptions</i>	44
3.3.2 <i>Using the architectural design and envelope to create low-energy buildings</i>	45
3.3.3 <i>Passive solar heating</i>	49
3.3.4 <i>Natural ventilation</i>	52
3.3.5 <i>Evaporative cooling and cooltowers</i>	57
3.3.6 <i>Ground-source heat pumps</i>	63

3.3.7	<i>Energy recovery ventilators</i>	65
3.3.8	<i>Electric resistance heating</i>	69
3.3.9	<i>HVAC controls</i>	69
3.4	Photovoltaic Systems	70
3.4.1	<i>Design grid-connected PV systems to have no parasitic standby loads</i>	73
3.4.2	<i>Consider an automatic monitoring system for PV system operation</i>	73
3.4.3	<i>Locate PV panels where they will not be shaded</i>	74
3.4.4	<i>Consider specifications for how a PV-based UPS system transitions to and from utility power</i>	75
3.4.5	<i>Use maximum power-point tracking controllers</i>	76
3.4.6	<i>Grid-connected PV systems and inverters should be carefully designed as an integrated system</i>	76
3.4.7	<i>Integrate PV systems with demand-responsive controls and on-site thermal storage to maximize energy cost savings and payback</i>	77
3.5	Peak Demand and Demand Management	78
3.5.1	<i>Low-energy buildings peak demand profiles</i>	81
3.5.2	<i>PV systems have had limited success reducing peak demands</i>	82
3.5.3	<i>Demand-responsive controls can save energy costs and increase load factors</i>	83
3.5.4	<i>Low-energy buildings can have low load factors</i>	86
3.6	Plug and Equipment Loads	87
3.6.1	<i>Parasitic loads should be minimized</i>	88
3.6.2	<i>Domestic hot water loads are small</i>	92
3.7	Postoccupancy Evaluation Techniques	94
3.7.1	<i>Determining whole-building energy savings</i>	94
3.7.2	<i>Measuring energy use</i>	101
3.7.3	<i>Daylighting evaluations</i>	104
3.7.4	<i>PV systems evaluations</i>	105
3.7.5	<i>Performance metrics</i>	106
4	Conclusions	109
4.1	Lessons Learned	109
4.1.1	<i>Applying a whole-building energy design process</i>	110
4.1.2	<i>Lighting and daylighting systems</i>	112
4.1.3	<i>Integrating the envelope and mechanical systems</i>	113
4.1.4	<i>Photovoltaic systems</i>	114
4.1.5	<i>Peak demand and demand management</i>	115
4.1.6	<i>Plug and equipment loads</i>	116
4.1.7	<i>Postoccupancy evaluation techniques</i>	116
4.2	Best Practices for High-Performance Buildings	118
4.3	Recommended Future Research	121
5	References	124
Appendix A: Zero-Energy Buildings: Definitions and Analysis		127
A.1	Boundary Definitions and Energy Flows	127
A.1.1	<i>Grid connection is allowed and necessary for energy balances</i>	127
A.1.2	<i>Prioritize supply-side technologies to those available on site and within the footprint</i>	127

A.2	Definitions.....	129
A.3	Low- and Zero-Energy Buildings: Examples	130
A.4	How Definition Determines Design.....	130
	<i>A.4.1 Net zero site energy building</i>	<i>130</i>
	<i>A.4.2 Net zero source energy building</i>	<i>131</i>
	<i>A.4.3 Net zero energy cost building</i>	<i>132</i>
	<i>A.4.4 Net zero energy emissions building</i>	<i>133</i>
	<i>A.4.5 ZEB definitions applied to a sample of current generation low-energy buildings</i>	<i>134</i>
	<i>A.4.6 The ZEB definition selected can have an impact on future ZEB designs.....</i>	<i>134</i>
Appendix B: National Daylighting Potential		136

ACKNOWLEDGMENTS

The authors would like to thank the U.S. Department of Energy's (DOE) Office of Building Technologies, which managed and funded this research.

The authors would also like to thank those who helped to edit and review the document: Peter Ellis, Stefanie Woodward, and Lauren Poole (NREL), Dru Crawley (DOE), Nadav Malin (BuildingGreen), Tom Wood (Montana State University), and Keith Emerson (United Power).

EXECUTIVE SUMMARY

Commercial buildings have a significant impact on energy use and the environment. They account for approximately 18% (17.9 quads) of the total primary energy consumption in the United States (DOE 2005). The energy used by the building sector continues to increase, primarily because new buildings are added to the national building stock faster than old buildings are retired. Energy consumption by commercial buildings will continue to increase until buildings can be designed to produce more energy than they consume. As a result, the U.S. Department of Energy's (DOE) Building Technologies Program has established a goal to create the technology and knowledgebase for marketable zero-energy commercial buildings (ZEBs) by 2025.

To help DOE reach its ZEB goal, the Buildings and Thermal Systems Center at the National Renewable Energy Laboratory (NREL) studied six buildings in detail over the past four years to understand the issues related to the design, construction, operation, and evaluation of the current generation of low-energy commercial buildings. These buildings and the lessons learned from them help inform a set of best practices—beneficial design elements, technologies, and techniques that should be encouraged in future buildings, as well as pitfalls to be avoided. The lessons learned from these six buildings are also used to guide future research on commercial buildings to meet DOE's goal for facilitating marketable ZEBs by 2025. The six buildings are:

- “Oberlin”—The Adam Joseph Lewis Center for Environmental Studies, Oberlin College, Ohio
- “Zion”—The Visitor Center at Zion National Park, Springdale, Utah
- “Cambria”—The Cambria Department of Environmental Protection Office Building, Ebensburg, Pennsylvania
- “CBF”—The Philip Merrill Environmental Center, Chesapeake Bay Foundation, Annapolis, Maryland
- “TTF”—The Thermal Test Facility, National Renewable Energy Laboratory, Golden, Colorado
- “BigHorn”—The BigHorn Home Improvement Center, Silverthorne, Colorado

High-Performance Buildings Case Study Reports

- [Energy Performance Evaluation of an Educational Facility: The Adam Joseph Lewis Center for Environmental Studies, Oberlin College, Oberlin, Ohio](#)
- [Evaluation of the Low-Energy Design and Energy Performance of the Zion National Park Visitor Center](#)
- [Analysis of the Design and Energy Performance of the Pennsylvania Department of Environmental Protection Cambria Office Building](#)
- [Analysis of the Energy Performance of the Chesapeake Bay Foundation's Philip Merrill Environmental Center](#)
- [Evaluation of the Energy Performance and Design Process of the Thermal Test Facility at the National Renewable Energy Laboratory](#)
- [Energy Design and Performance Analysis of the BigHorn Home Improvement Center](#)

Each of the six commercial buildings we studied has a unique purpose and function, but all have commonalities. Each building must provide visual, acoustic, and thermal comfort for the occupants. All must stand up to climatic conditions, and all must meet or exceed the programmatic requirements for their spaces. The six buildings in this study are successful in these respects, and are all good energy performers. All had owners who pushed low-energy or sustainability goals and considered energy efficiency as part of the decision-making process. The architects and engineers then created a design to implement the vision, which required a whole-building design process to achieve the goals. The whole-building design process requires that the team responsible for the building design, including the architect, engineers (lighting, electrical, and mechanical), energy and other consultants, and the building's owner and occupants—work together to set and understand the energy performance goals. The purpose of the

whole-building design approach is to enable the full design team to interact throughout the design process to fully understand the building systems' interdependencies. A systematic analysis of these interdependencies can help ensure that a much more efficient and cost-effective building is produced.

Various incarnations of the whole-building design process were used to produce the buildings documented in the case studies. For Zion, BigHorn, and TTF, we were directly involved in the design process, providing energy analysis and facilitating the design process as it applied to energy performance. We monitored all six buildings after they were built for at least one year and analyzed the data to determine their energy performance with respect to design goals.

All the buildings use innovative combinations of “state-of-the-shelf” energy technologies to reduce their energy use and minimize their environmental impacts. The buildings all have thermal envelopes that exceed current energy codes. They also use daylighting, radiant heating, natural ventilation, evaporative cooling, ground-source heat pumps, photovoltaics (PV), and passive solar strategies. All use much less energy than comparable energy code-compliant buildings. We found that the buildings' energy consumption was 25% to 70% lower than code. Although each building is a good energy performer, additional energy efficiency is required for these buildings to reach DOE's ZEB goal. We learned a great deal from these case studies about the whole-building design process and about which technologies work best under given circumstances.

Lessons Learned Summary

Below is a summary list of lessons learned that applied to all six case study buildings:

- **Owners provide the main motivation for low-energy buildings.** The owner was the driving force in each case. Each owner set the goals and made decisions to keep the project on track. The architects and engineers strived to meet the goals of the building owners, which resulted in the need for the whole-building design process.
- **Setting measurable energy saving goals at the outset of the project is crucial to realizing low-energy buildings.** In the case studies, all the owners and design teams set aggressive energy saving goals at the outset. The goals ranged from 40% better than code to net-zero energy performance. In general, the teams that set the strongest energy performance goals and used energy simulation to understand the energy impacts of design decisions had the best energy performance.
- **Many decisions are not motivated by cost.** Building owners make decisions based on values. Quite often owners will pay for features they really want in a building—this is especially true of architectural features. Conversely, if an owner does not want a feature, cost is often used as the reason to eliminate it.
- **Today's technologies can substantially change how buildings perform.** Properly applied off-the-shelf or state-of-the-shelf technologies are available to achieve low-energy buildings. However, these strategies must be applied together and properly integrated in the design, installation, and operation to realize energy savings. There is no single efficiency measure or checklist of measures to achieve low-energy buildings.
- **A whole-building design approach is a good way to lower energy use and cost.** An integrated whole-building approach begins with a design team that is committed to the energy goals. The building must be engineered as a system if the technologies are to be integrated in design and operation. This included using computer simulations to help guide the design process—these simulations can perform trade-off analysis to examine energy impacts of architecture choices and HVAC&L (heating, ventilation, air-conditioning, and lighting) designs.
- **Low-energy buildings do not always operate as they were designed.** The design community rarely goes back to see how their buildings perform after they have been constructed.

Measurements in all six buildings showed that they used more energy and produced less energy than predicted in the design/simulation stage. Several reasons were documented:

- There was often a lack of control software or appropriate control logic to allow the technologies to work well together.
 - Design teams were too optimistic about the behavior of the occupants and their acceptance of systems.
 - Energy savings from daylighting were substantial, but were generally less than expected.
 - Plug loads were often greater than design predictions.
 - Effective insulation values are often inflated when comparing the actual building to the as-designed building.
 - PV systems experienced a range of operational performance degradations. Common degradation sources included snow, inverter faults, shading, and parasitic standby losses.
- **Information leads to better management and improved performance.** Setting and following design goals or traditional commissioning does not guarantee that the goals will be satisfied in actual operations. The whole-building energy performance must be tracked and verified. Monitoring provides valuable feedback that can help maintain the efficient performance of systems to ensure design goals are met.
 - **This set of current generation low-energy buildings shows progress toward achieving a ZEB goal in actual buildings.** Each of these buildings saved energy, with energy use 25% to 70% lower than code. Although each building is a good energy performer, additional energy efficiency and on-site generation is required for these buildings to reach DOE's ZEB goal. At current levels of performance, the one-story buildings—Zion, BigHorn, and TTF—could accomplish the ZEB goal with PV systems that would fit within the building footprint. ZEBs are not feasible for the two-story buildings within their footprints unless their loads are reduced.
 - **We can replicate the lessons learned from these case studies in future low-energy buildings.** Even though every commercial building is unique, the lessons learned from these case studies can be applied to a wide variety of commercial buildings. The buildings and the lessons learned from them help to define a set of best practices. Best practices are proven real-world technologies and processes that lead to high-performance buildings. Understanding success and opportunities in the current generation of low-energy buildings can improve the energy efficiency of all commercial buildings—the best practices should be applied to future buildings.

Best Practices for High-Performance Buildings

The lessons learned from the six case studies have helped to define this set of best practices that should be applied to the design, construction, and operation of future low- and zero-energy buildings.

1. **Use a whole-building design process to design, construct, and operate future low-energy buildings.** This includes:
 - a. Set a specific, quantifiable energy design goal that is used to guide the design process and can be verified during operation.
 - b. Include everyone involved in the project starting at the earliest stages of the design process.
 - c. Use whole building simulation tools to determine the energy performance of the building at all stages of design, construction, and occupancy. The whole-building design process is a simulation-based, quantitative, and qualitative method to help architects and engineers create low-energy buildings. The energy use and energy cost of a building depend on the complex interaction of many parameters and variables—best studied with computerized energy

- simulation software to thoroughly evaluate all interactions between the building envelope, HVAC system, and design features.
- d. Design the building envelope such that it can be used to meet as many loads as possible. The envelope should be the first method of creating low-energy buildings; the mechanical and lighting systems should then be sized to meet any remaining loads. Low-energy architecture is not effective if mechanical systems have to solve problems that result from the architectural design.
 - e. Update the design simulations from predesign through occupancy to ensure the design simulations will measure up to actual performance.
2. **Provide for a postoccupancy energy performance evaluation (POE).** Commissioning a new building is essential, but it ensures only that the building components operate as specified. All six case studies were commissioned either formally or informally. In general, the traditional commissioning did not necessarily translate to expected energy performance or verify low-energy design goals. Continual monitoring of the performance during the POE, or continuous system commissioning with key performance metrics, is important to ensure that the goals of the design are met under normal operating conditions.
 3. **Implement measurement procedures such as those developed in DOE’s Performance Metrics Research Project.** Obtaining reliable metrics for determining a building’s performance is one of the core challenges to achieving widespread adoption of high-performance buildings. Currently available procedures for determining performance metrics are available in the following documents:
 - a. *Procedure for Measuring and Reporting Commercial Building Energy Performance* (Barley et al. 2005)
 - b. *Procedure to Measure Indoor Lighting Energy Performance* (Deru et al. 2005b)
 - c. *Procedure for Measuring and Reporting the Performance of Photovoltaic Systems in Buildings* (Pless et al. 2005)
 - d. *Procedure for Developing a Baseline Simulation Model for a Minimally Code-Compliant Commercial Building* (Pless, Deru, and Torcellini 2006)
 - e. *Standard Definitions of Building Geometry for Energy Evaluation Purposes* (Deru and Torcellini 2005)
 - f. *Procedure to Determine Source Energy and Emissions for Energy Use in Buildings* (Deru and Torcellini 2006)
 4. **Integrate daylighting into the envelope and lighting systems.** Controlling the electric lighting when daylighting is available works in all climates and in almost any type of building. A good daylighting design should result from an integrated design process. The daylighting system has to be integrated with the envelope and trade-offs with heating and cooling understood to maximize whole-building energy savings. Use the following best practices to integrate daylighting with the lighting systems:
 - a. Design daylighting into all occupied zones adjacent to an exterior wall or ceiling.
 - b. Provide integral glare mitigation techniques in the initial design.
 - c. Provide automatic, continuously dimming daylighting controls for all daylit zones.
 - d. Design interiors to maximize daylighting distribution (no dark surfaces).
 - e. Integrate the electrical lights with the daylighting system.
 - f. Commission and verify postoccupancy energy savings.
 5. **Use economizers in conjunction with energy recovery ventilators (ERVs).** The control and systems integration of economizers, natural ventilation, and ERVs needs to be very carefully

designed and implemented. Natural ventilation or ERVs, as implemented in the buildings we studied, were not as good as the conventional economizers they replaced. Systems with ERVs and ground-source heat pumps should have economizers for when conditions warrant. ERVs should be operated when recovered energy is a net saving to the building. In addition, ERVs should be used only when needed, as part of a demand-responsive ventilation system.

6. **Use evaporative cooling systems in dry climates.** All cooling requirements in dry climates can be met with evaporative cooling systems. If more thermal and latent control is needed, evaporative cooling can be used as a first stage.
7. **Design natural ventilation systems with the following best practices:**
 - a. Design natural ventilation to rely primarily on stack effect unless wind direction and speeds are reliable.
 - b. Separate natural ventilation supply and relief from the fenestration and use relief dampers for the passive ventilation.
 - c. Use automatic supply and relief controls that do not rely on occupant interaction.
 - d. Minimize use of enclosed spaces.
 - e. Do not use natural ventilation systems as a replacement for conventional economizers.
8. **Use demand-responsive controls that integrate on-site storage, daylighting, and energy production to reduce peak demand charges and increase load factors.** An efficient building that uses very little energy could still have large demand charges. Load factors are low primarily because PV systems reduce energy use, but may not reduce peak demands. The same is true of daylighting and strategies to reduce ventilation. Demand-responsive strategies that integrate on-site generation with the thermal capacity of the building require controls that allow the building temperature to float based on instantaneous consumption and production. Using PV generation to further reduce peak demands is typically the most cost-effective use of this resource.

Future Research Recommendations

To help DOE reach its ZEB goal by 2025 and to continue to reduce the energy consumption in commercial buildings, we recommend the following, based on our experience with the six case study buildings. Details of each recommendation are included in Section 4.3.

1. Standardized methods should be used to collect data and determine energy savings to report building performance.
2. Future research efforts should start with the lessons learned from the six case studies.
3. Future ZEB research efforts should contain an element to focus on building owners and developers.
4. Develop integrated HVAC equipment, systems, and control packages.
5. Develop integrated whole-building lighting system packages.
6. Use simulation tools to develop technology option sets.
7. Develop regional time-dependent valuations for a time-of-day source electricity conversion rate throughout the country.
8. Investigate methods to further increase the energy efficiency of equipment and plug loads.
9. Evaluate the technical viability of and marketability of key successful strategies for wide-scale deployment.
10. Study the degradation of long-term whole-building energy performance.
11. Study the ability for PV systems combined with on-site storage and advanced control to minimize peak demand charges.

ACRONYMS

AC	Alternating Current
ASHRAE	American Society of Heating, Refrigerating, and Air-Conditioning Engineers
CBECS	Commercial Building Energy Consumption Survey
CBF	Chesapeake Bay Foundation
CMU	Concrete Masonry Unit
DAS	Data Acquisition System
DC	Direct Current
DEP	Department of Environmental Protection
DHW	Domestic Hot Water
DOE	U.S. Department of Energy
ECI	Energy Cost Intensity
EMS	Energy Management System
ERV	Energy Recovery Ventilator
EUI	Energy Use Intensity
HVAC	Heating, Ventilation, and Air Conditioning
HVAC&L	Heating, Ventilation, Air Conditioning, and Lighting
IESNA	The Illuminating Engineering Society of North America
LEED	Leadership in Energy and Environmental Design
LPD	Lighting Power Density
MPPT	Maximum Power Point Tracker
NPS	National Park Service
NREL	National Renewable Energy Laboratory
POE	Postoccupancy Evaluation
PV	Photovoltaic
SHGC	Solar Heat Gain Coefficient
TDV	Time-Dependent Valuation
TTF	Thermal Test Facility
UPS	Uninterruptible Power Supply
USGBC	United States Green Building Council
VSD	Variable Speed Drive
ZEB	Zero Energy Building

1 INTRODUCTION

Commercial buildings have a significant impact on energy use and the environment. They account for approximately 18% (25.9 quads) of the total primary energy consumption in the United States (DOE 2005). The total for all buildings is more than one-third of the primary energy consumption and approximately 70% of the electricity consumption (see Figure 1-1). Buildings in the United States are responsible for 38% of U.S. and 9% of global carbon dioxide (CO₂) emissions.

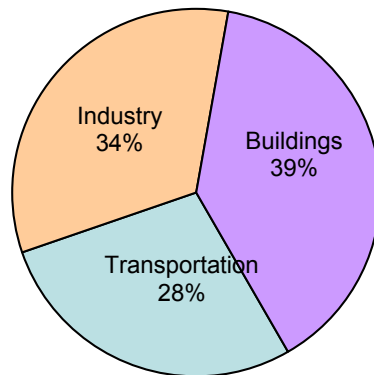

Figure 1-1 Energy use by sector in the United States

Building energy consumption will continue to increase in the near future. Electricity consumption in the commercial building sector doubled between 1980 and 2000, and is expected to increase another 50% by 2025 (EIA 2005a.) Furthermore, new buildings are added to the national building stock faster than old buildings are retired. The percentage share attributed to the building sector is also increasing because of reduced growth in the industrial sector.

Reducing energy consumption in commercial buildings through energy efficiency and renewable energy technologies would significantly reduce primary energy consumption in the United States (EIA 2005a). Toward this end, the U.S. Department of Energy (DOE) has set an aggressive goal to create the technology and knowledge base for marketable and cost-effective commercial zero-energy buildings (ZEBs) by 2025. ZEBs are high-performance buildings designed to generate as much energy as they use over the course of a year to result in net-zero energy consumption.

To help DOE reach its ZEB goal, the Buildings and Thermal Systems Center at the National Renewable Energy Laboratory (NREL) studied six high-performance buildings over the past four years to evaluate and understand their operating energy performance. Each building was designed to minimize energy and environmental impacts and used a variety of low-energy technologies. The buildings represent a range of climates and uses. They are all good energy performers. Understanding the energy performance of the current stock of high-performance buildings is an important step toward reaching the ZEB goal.

1.1 Problem Definition

A problem with getting high-performance buildings into the marketplace is that owners and designers hesitate to try new innovative technologies and processes that have not yet been adopted by the mainstream. Owners are unsure what potential energy savings goals are achievable. Someone always has to be first to use a technology. A few building owners and designers have made great strides to significantly change the way commercial buildings use energy. They have documented the performance of sustainable buildings with respect to energy and identified lessons learned from their experience. These case studies illustrate owners and designers who have been early adopters. Publishing case studies

and summarizing lessons learned encourages others to build low-energy buildings and can help to prevent errors from being repeated. Additionally, postoccupancy evaluation (POE) of these leading-edge buildings demonstrates the progress toward achieving DOE goals in real-world examples.

1.2 Methodology

NREL documented the design process and operating performance of the six buildings in separate detailed case study reports. The objectives of the case studies were to develop, analyze, evaluate, and document the technologies, processes, and methods by which high-performance buildings can be reliably produced. These case studies provide detailed building descriptions, documentation, and evaluation of monitored and simulated energy performance, as well as lessons learned about designing, operating, and evaluating each building.

NREL completed the case study reports in FY 2005. The reports include:

- *Energy Performance Evaluation of an Educational Facility: The Adam Joseph Lewis Center for Environmental Studies, Oberlin College, Oberlin, Ohio*
www.nrel.gov/docs/fy05osti/33180.pdf
- *Evaluation of the Low-Energy Design and Energy Performance of the Zion National Park Visitors Center*
www.nrel.gov/docs/fy05osti/34607.pdf
- *Analysis of the Design and Energy Performance of the Pennsylvania Department of Environmental Protection Cambria Office Building*
www.nrel.gov/docs/fy05osti/34931.pdf
- *Analysis of the Energy Performance of the Chesapeake Bay Foundation's Philip Merrill Environmental Center*
www.nrel.gov/docs/fy05osti/34830.pdf
- *Evaluation of the Energy Performance and Design Process of the Thermal Test Facility at the National Renewable Energy Laboratory*
www.nrel.gov/docs/fy05osti/34832.pdf
- *Energy Design and Performance Analysis of the BigHorn Home Improvement Center*
www.nrel.gov/docs/fy05osti/34930.pdf

Each case study developed a list of lessons learned and recommendations relevant to that unique building. This report combines the overarching lessons learned. Although the case studies represent a variety of designs and climates, we looked at all six together to understand common successes and failures. We then distilled these and other wisdom acquired along the way into a set of lessons learned.

The term *lessons learned* refers to positive and negative aspects of a project that have clear messages and might help subsequent low-energy building projects. The lessons learned are intended as recommendations either for changes to these buildings or for concepts that should be applied to the next generation of low-energy buildings. Members of future building projects should keep these lessons in mind and realize that they should be considered jointly along with the goals for saving energy. Lessons learned are key educational components. They should help design teams avoid repeating problems and identify where the process of delivering buildings needs to be changed to promote and realize low- and zero-energy buildings.

We then used these buildings and their lessons learned to help identify and define a set of *best practices*—proven, real-world low-energy building technologies and processes that should be carried forward in future buildings.

1.3 Goals and Objectives

The goal of this report is to combine and highlight the primary overarching lessons learned from the case studies to help inform and direct future design studies and implementations to work towards ZEBs. The specific objectives are to:

- Summarize lessons learned from the six case studies and show common trends and gaps in technologies, design methodologies, energy performance, and operational strategies.
- Identify the forces that drive decision making related to energy efficiency and integrated design.
- Identify limitations in the application of innovative technologies and plan investigations of subtopics such as integrated daylighting, natural ventilation, performance degradation over time, and demand-responsive controls.
- Evaluate instrumentation and analysis techniques for POEs.
- Develop a list of best practices to guide the design of future high-performance buildings.
- Identify research areas where the case study buildings and existing instrumentation could be leveraged for further study.

1.4 Report Organization

The report is presented in four sections: Section 1 introduces the problem definition and methodology used in this research; Section 2 describes the design, low-energy features, and energy performance of the six case study buildings; Section 3 describes the lessons learned as they relate to the low-energy design process, low-energy building technologies, and evaluation techniques; and Section 4 summarizes our findings, formulates a list of best practices, and offers recommendations for future research.

Additional information on defining a zero energy building and a national daylighting potential analysis is located in the appendices. We also encourage the reader to consult the individual case study reports via the links provided in Section 1.2.

2 CASE STUDIES

NREL analyzed the energy performance of six commercial buildings constructed over the past decade to understand how they performed and to verify their design goals. Each building design team included sustainability among its initial project goals and worked to minimize the energy and environmental impacts of the project. From the beginning, the teams set aggressive energy-saving goals that ranged from 40% better than code to net-zero energy performance. Some teams also had ambitious goals in other areas of sustainability such as water management, building materials selection, or obtaining a high LEED® (Leadership in Energy and Environmental Design) score (USGBC 2004). All buildings have thermal envelopes that exceeded the then-current versions of the building energy code (ANSI/ASHRAE/IESNA Standard 90.1) at the time of construction. In addition, a variety of other energy-saving strategies were used, such as daylighting, radiant heating, natural ventilation, evaporative cooling, ground-source heat pumps, photovoltaic (PV) systems, and passive solar heating. The buildings studied include:

- “Oberlin”—The Adam Joseph Lewis Center for Environmental Studies, Oberlin College
- “Zion”—The Visitor Center at Zion National Park, Springdale, Utah
- “Cambria”—The Cambria Department of Environmental Protection Office Building, Ebensburg, Pennsylvania
- “CBF”—The Philip Merrill Environmental Center, Chesapeake Bay Foundation, Annapolis, Maryland
- “TTF”—The Thermal Test Facility, National Renewable Energy Laboratory, Golden, Colorado
- “BigHorn”—The BigHorn Home Improvement Center, Silverthorne, Colorado

NREL was directly involved during the design process for three of the buildings (BigHorn, TTF, and Zion). Computer simulations of energy performance were used to help guide each design: first by evaluating envelope options, then by designing mechanical systems that matched the building’s predicted loads. The case studies include an evaluation of the whole-building design process. We did not participate in the design process for Oberlin, CBF, or Cambria.

Postoccupancy evaluations were performed for all six buildings, including intensive monitoring for at least one year. The monitoring procedure measured energy flows for the whole building, including major subloads, such as lighting, heating, ventilation, air-conditioning, and plug and equipment loads. In some cases, additional monitoring further disaggregated end-use loads to better characterize the building. Measured data were later used to calibrate simulation models of the building energy performance. Code-compliant baseline and calibrated as-built models were simulated to determine site, source, and energy cost savings.

Performance metrics were established to evaluate and compare building energy performance. On-site energy generation from a PV system makes it important to distinguish between total and net energy use. *Site energy* refers to the total energy consumed by the building but does not include on-site generation. *Net site energy* refers to the total energy consumed by the building minus the energy produced by on-site generation; this is what the utility meter measures under a net-metering arrangement. Different fuel types, i.e., electricity and natural gas, make it necessary to distinguish between site and source energy. *Net source energy* represents primary energy use and is calculated from *net site energy* by applying national site-to-source conversion factors of 3.215 for electricity and 1.072 for natural gas (EIA 2005). All numbers are reported as facility totals and include plug loads and site lighting.

A brief description of each building and its energy performance follows. A summary of the energy performance for all six buildings appears at the end of this section.

2.1 Adam Joseph Lewis Center for Environmental Studies, Oberlin College

The Adam Joseph Lewis Center for Environmental Studies at Oberlin College in Oberlin, Ohio, is a two-story, 13,600-ft² (1,265-m²) classroom and laboratory building. The building contains four classrooms, a small auditorium, atrium, staff offices, and kitchenette. The design team envisioned a building with the potential to develop into a ZEB as technologies improve. The objective was to promote innovative technologies and create an educational tool for the Environmental Studies Program at the college.

The integrated building design includes daylighting to offset lighting loads, natural ventilation to offset cooling loads, massive building materials to store passive solar gains, a ground-source heat pump system to meet the cooling and heating loads, an energy management system (EMS), and a system to process wastewater without sending the waste to the municipal sewage treatment plant. Because of the zero-energy vision, the building was designed to be all electric, such that on-site energy generation could offset 100% of the energy consumed. The roof is covered with a grid-tied, 60-kW PV array (Figure 2-1).



Figure 2-1 South elevation of Oberlin showing roof-mounted PV array

Measured annual site energy use was 29.8 kBtu/ft² (338 MJ/m²), or 47% less than the whole-building simulation of an ASHRAE Standard 90.1-2001 comparable code-compliant building. PV panels provided 45% of the total electric load of the building for a net site energy use of 16.4 kBtu/ft² (186 MJ/m²). As a point of reference, the energy use is less than half that of the average Midwestern educational building: 79 kBtu/ft² (897 MJ/m²) (EIA 2005a). The source energy requirements of Oberlin are also very low at 39.7 kBtu/ft² (451 MJ/m²), or 77% less than the code-compliant building.

These results show that a high-performance academic building with heating and cooling loads is possible in a humid climate. However, a ZEB in this climate will be very difficult to realize, especially with on-site wastewater treatment loads. Additional PV capacity that extends beyond the footprint of the building and better control algorithms would be required to meet the zero-energy vision with today's technology. The complete case study report (Pless and Torcellini 2005) is available at www.nrel.gov/docs/fy05osti/33180.pdf.

2.2 Zion Visitor Center

The Visitor Center Complex at Zion National Park in southwestern Utah exemplifies the National Park Service's commitment to promote conservation and minimize impact on the natural environment. The building design incorporates energy-efficient features such as daylighting, natural ventilation, cooltowers, passive solar heating, solar load control with engineered overhangs, computerized building controls, and an uninterruptible power supply (UPS) system integrated with the 7.2-kW PV system (Figure 2-2).

Two conditioned buildings were constructed: an 8,800-ft² (820-m²) main Visitor Center building that contains a retail bookstore, a visitor orientation area, and support areas; and a 2,756-ft² (256-m²) restroom facility. Landscaping in the outdoor exhibit areas and between the buildings creates outdoor rooms that increase the effective space available for visitor amenities without increasing energy consumption.

The innovative heating and cooling systems eliminated all ductwork and fuel storage from the project. Passive solar heating augmented with localized electric heating systems met the heating needs. The electric heating systems are controlled to purchase electricity when demand charges will not be incurred. The cooltowers eliminated the need for conventional air-conditioning. The cooltowers use a wetted medium at the top of a tower. Cool air naturally falls down the tower and into the building without fans. Two fractional horsepower water pumps drive the entire cooling system. Because there is less heating, ventilation, and air-conditioning (HVAC) equipment, the building was constructed at a slightly lower cost than a conventional national park visitor center.

The building's energy performance has been evaluated since May 2000. The integrated design resulted in a building complex that costs \$0.43/ft² (\$4.63/m²) to operate and consumes 27.0 kBtu/ft² (307 MJ/m²). During the monitored year, the PV system produced a net 7,900 kWh or 8.5% of the annual energy use. The complete case study (Torcellini et al. 2005a) is available at www.nrel.gov/docs/fy05osti/34607.pdf.



Figure 2-2 North elevation of the Zion Visitor Center showing cooltowers and plaza

2.3 Cambria Office Building

The Cambria Office Building in Ebensburg, Pennsylvania, has an area of 34,500 ft² (3,205 m²) and serves as the district office for Pennsylvania's Department of Environmental Protection (DEP). The design team used the U.S. Green Building Council's LEED 2.0 requirements as design guidelines and goals. Among the low-energy design features used in this building are ground-source heat pumps, an under-floor air distribution system, heat recovery ventilators, an 18.2-kW PV system, daylighting, motion sensors, additional wall and roof insulation, and high-performance windows (Figure 2-3). Pennsylvania's DEP further reduces the impact of the building operations by purchasing 100% utility-based renewable energy. The selection of finishes, including carpets, walls, furniture, and paints, was based on recycled content and low emissions.

The integrated energy design of this all-electric building produced an energy saving of 40% and an energy cost saving of 43% compared to ASHRAE Standard 90.1-2001. The lighting and HVAC efficiencies accounted for most of the savings. Some daylighting was used, but saved minimal energy. The PV array covers about 40% of the roof and provides approximately 2.7% of the annual energy. Operational problems with the PV system have been corrected and the energy production is expected to double. The complete case study (Deru et al. 2005) is available at www.nrel.gov/docs/fy05osti/34931.pdf.



Figure 2-3 South elevation of the Cambria Office Building

2.4 Philip Merrill Environmental Center, Chesapeake Bay Foundation

The Chesapeake Bay Foundation (CBF) in Annapolis, Maryland, is dedicated to restoring and protecting the resources of the Chesapeake Bay. CBF built the 31,000-ft² (2,900-m²) Philip Merrill Environmental Center on previously disturbed land. Native and recycled materials were used throughout the construction.

CBF uses a ground-source heat pump system for heating and cooling. Forty-eight wells, each 300 ft (91 m) deep, use the ground as a heat sink in the summer and as a heat source in the winter. A glazed wall of windows on the south contributes daylight and passive solar heating. Operable windows are used for natural ventilation; the natural ventilation can be augmented with fans. The shed roof collects rainwater for fire protection, landscape watering, and clothes and hand washing (Figure 2-4). Composting toilets also minimize water use.



Figure 2-4 North elevation of the Philip Merrill Environmental Center

CBF was assessed by comparing measured performance to ASHRAE Standard 90.1-2001. For the monitoring period, the total site energy use saving was 24.5%, the source energy saving was 22.1%, and the energy cost saving was 12.1%. The complete report (Griffith et al. 2005) is available at www.nrel.gov/docs/fy05osti/34830.pdf.

2.5 Thermal Test Facility

The TTF at NREL in Golden, Colorado, is a 10,000-ft² (930-m²) steel-frame building that is typical of many small professional buildings, industrial parks, and retail structures. The building was designed to

be an example of an economical and simple low-energy building. Efficiency features include extensive daylighting through clerestory windows, two-stage evaporative cooling, overhangs to minimize summer solar gains, T-8 lamps, instantaneous water heaters, and a well-insulated thermal envelope (Figure 2-5).



Figure 2-5 Thermal Test Facility at NREL

The integrated design and energy features of the TTF have resulted in an energy cost saving of 51% and a site energy saving of 42% as compared to the Federal Energy Code 10 CFR 435 (DOE 1995). Daylighting provided the most significant energy saving. The lighting design and daylight harvesting reduced lighting energy by 75%. In this dry climate, two-stage evaporative cooling provides sufficient cooling capacity for less energy than conventional cooling systems. The building was built at a similar cost to a conventional building; however, an overall evaluation of the project by an independent estimator showed an approximate increase of 3.5% because of the energy features. Like the other projects, some of these features were integral to the architecture of the building. The complete case study (Torcellini et al. 2005b) is available at www.nrel.gov/docs/fy05osti/34832.pdf.

2.6 BigHorn Home Improvement Center

The BigHorn Home Improvement Center in Silverthorne, Colorado, consists of an 18,400-ft² (1,710-m²) hardware store retail area and a 24,000-ft² (2,230-m²) warehouse (Figure 2-6). The owner was committed to using renewable energy and a building design optimized for minimal energy use. Reduced internal gains from lighting and smart envelope design in the retail area allowed for the use of natural ventilation to meet all cooling loads. The lighting load is reduced by extensive use of daylighting facilitated by the switching arrangement of the fluorescent lights. The retail area uses a hydronic radiant floor system with natural gas-fired boilers. An EMS controls the lights, natural ventilation, and heating system. A transpired solar collector and gas radiant heaters heat the warehouse.



Figure 2-6 BigHorn Home Improvement Center

The integrated design of BigHorn yielded source energy savings of 54% and energy cost savings of 53%; annual energy costs were \$0.43/ft² (\$4.63/m²) as compared to ASHRAE Standard 90.1-2001. The lighting design and daylighting reduced electric lighting use by 93% in the warehouse and 67% in the retail and office areas. The PV system provides 2.5% of the annual electrical energy; the highest monthly percentage was 7.3% in July 2002. The additional building cost was approximately 10% greater than conventional construction. Some of the energy-related costs substantially enhanced the architecture of the building. The complete case study (Deru, Torcellini, and Pless 2005) is available at www.nrel.gov/docs/fy05osti/34930.pdf.

2.7 Energy Performance Summary

Several performance metrics are used to summarize the annual energy results in the six case studies. The absolute energy performance is summarized in terms of energy use intensity (EUI) and energy cost intensity (ECI) (see Figure 2-7). EUI and ECI are normalized by the building floor area. The net source EUI and ECI numbers include PV; site EUI does not. When considering net source EUI, keep in mind that Oberlin, Zion, and Cambria are all-electric buildings; CBF is primarily electric with propane backup; and TTF and BigHorn use natural gas heating systems.

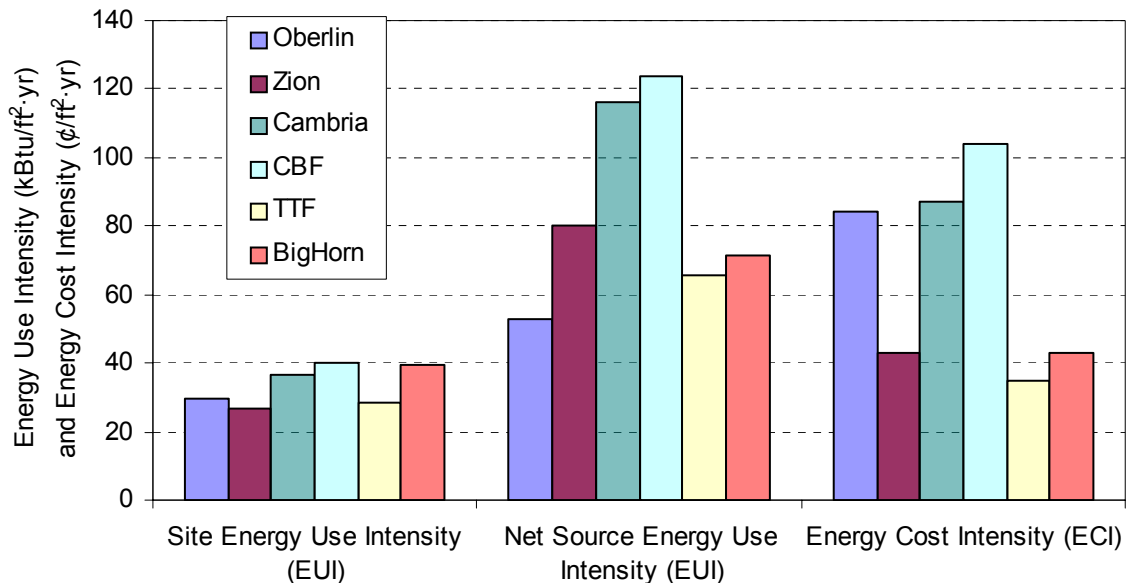

Figure 2-7 Summary of energy performance metrics

Energy-efficient technologies are not the only influences on energy performance for these buildings. Although low site EUI is directly related to the efficiency measures in each building, source EUI and ECI are influenced by external factors. As shown in Figure 2-7, site EUIs over all the buildings range from 27 kBTu/ft² to 40 kBTu/ft² (307 MJ/m² to 454 MJ/m²); ECIs and net source EUIs have a much greater distribution over the buildings. ECIs vary widely, ranging from \$0.35/ft² to \$1.04/ft² (\$3.77/m² to \$11.19/m²). The lowest source EUI is 53 kBTu/ft² (602 MJ/m²) and the highest is 124 Btu/ft² (1,408 MJ/m²). Differences in utility rate structures, peak demand profiles, fuel types and associated source energy conversions, and on-site production contribute to the variability in ECI and source EUI metrics, despite comparatively consistent site energy use among the buildings.

All three metrics are necessary for determining and comparing the energy performance of these buildings. However, the relative importance of each metric depends on the building's design goals. TTF, BigHorn,

Cambria, and Zion were designed to reduce energy costs. Oberlin was designed to reduce net source energy. CBF was designed to obtain a LEED V1.0 Platinum rating. Further comparison of operating energy performance to design goals is provided in Section 3.1.2.2.

Energy savings provide another layer of performance metrics to consider when evaluating and comparing energy performance. Relative energy performance for each of the case studies is summarized in terms of energy savings in Figure 2-8. Energy savings are determined by comparing the actual energy use to a standard benchmark, such as the energy use of a conventional building that just meets a minimum building energy code. Figure 2-8 shows net source, net site, site, and cost savings for each building. The net source, net site, and energy cost savings metrics include PV production, while the site energy savings metric does not include PV.

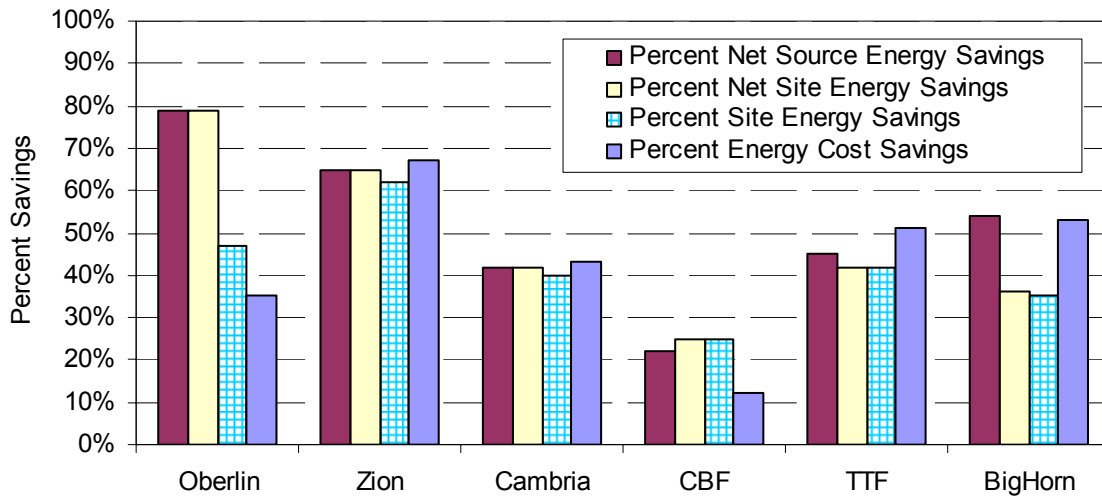

Figure 2-8 Summary of savings performance metrics

All these buildings are considered low energy, with a wide range of savings, depending on the metric selected. Zion saved 60% to 67% over all the savings metrics, and is one of the better energy performers in this set. Aggressive demand management controls at Zion, which none of the other buildings used, resulted in significant energy cost savings. Additionally, the integrated design process was successful at Zion, which integrated the HVAC and lighting systems with the building envelope. Oberlin had the greatest net source energy savings, primarily because of the large PV system. CBF set and achieved a design goal of a LEED V1.0 Platinum certification. Saving energy was a design consideration, but was not the primary design goal.

These buildings were further investigated to determine additional PV system requirements to meet ZEB goals. PV system array area and system capacity requirements for meeting a site, source, cost, and emissions ZEB goals were analyzed in each case. See Appendix A for details of these ZEB definitions as applied to the case studies and a discussion of the design impacts of the definition used.

Table 2-1 Summary of Energy Use, Savings, and Design Goals for each of the Six Case Study Buildings

Metric		Oberlin	Zion	Cambria	CBF	TTF ¹	BigHorn
Benchmark	ASHRAE Standard 90.1 Version	2001	1995 ²	2001	2001	1995 ²	2001
Annual Performance³	Energy Cost \$/ft ²	0.84	0.43	0.87	1.04	0.35	0.43
	Site Energy Consumption kBtu/ft ² (MJ/m ²)	29.8 (338)	27.0 (307)	36.8 (418)	40.2 (457)	28.5 (324)	39.5 (449)
	PV Production kBtu/ft ² (MJ/m ²)	13.4 (152)	2.3 (26)	0.9 (10)	0.3 (3)	0 ⁴ (0)	0.4 (5)
	Net Site Energy kBtu/ft ² (MJ/m ²)	16.4 (186)	24.7 (281)	36.0 (409)	39.9 (453)	28.5 (324)	39.2 (445)
	Net Source Energy kBtu/ft ² (MJ/m ²)	52.7 (598)	79.3 (901)	115.7 ⁵ (1314)	124.0 (1408)	65.7 (746)	71.3 (810)
	PV Contribution to Site Energy, %	45%	8.5%	2.7%	0.7%	0% ⁴	2.3%
Savings⁶	Net Source Energy Saving, %	79%	65%	42%	22%	45%	54%
	Net Site Energy Saving, %	79%	65%	42%	25%	42%	36%
	Site Energy Saving, %	47%	62%	40%	25%	42%	35%
	Energy Cost Saving, %	35%	67%	43%	12%	51%	53%
Project Goal Comparison	Design Goal or Predicted Performance	Net site energy use: 0.0 kBtu/ft ²	Energy Cost Saving: 80%	Energy Cost Saving: 66% ⁷	LEED 1.0 Platinum rating	Energy Cost Saving: 70% ⁸	Energy Cost Saving: 60% ⁸
	Measured or Simulated Performance	Net site energy use: 16.4 kBtu/ft ²	Energy Cost Saving: 67%	Energy Cost Saving: 44%	LEED 1.0 Platinum rating	Energy Cost Saving: 51%	Energy Cost Saving: 53%

Notes:

1. TTF was monitored for select periods. Actual data were used to calibrate simulations.
2. Code used was 1995 Federal Energy Code, 10 CFR 435 (DOE 1995). Based on ASHRAE 90.1-1989 (ASHRAE 1989) with more stringent lighting power densities.
3. TTF annual performance data are based on simulations verified with actual data and run with typical weather. All other annual performance data are based on monitored performance.
4. No PV installed on building.
5. The Cambria office building purchases 100% green power (nonhydro renewable energy); therefore, the source energy could be calculated assuming only a 9% loss for transmission and distribution (EIA 2005).
6. Oberlin, Bighorn, TTF, and Cambria energy savings were calculated with simulations of as-built and base-case buildings with typical weather data. Zion and CBF savings calculated with measured data and base-case simulations run with measured weather data.
7. The predicted energy costs were calculated before construction and may not indicate future performance because of volatile energy prices.
8. Goal was set on savings excluding plug loads.

3 LESSONS LEARNED

This section discusses the lessons learned from the six case studies. Findings are presented and categorized as they relate to the low-energy design process, low-energy building technologies, and evaluation techniques. The term *lessons learned* refers to positive and negative aspects of a project that have clear messages and might help subsequent low-energy building projects. They are intended as observations that can help identify best practices, either for improvements to these buildings, or concepts that worked and should be applied to future buildings. Readers should remember that these lessons and best practices must be considered together with the goals for saving energy. They should help to identify where the process of delivering buildings needs to be changed to promote and realize extremely low-energy buildings.

3.1 Applying a Whole-Building Design Process

In the traditional building design process, the architectural team works with the owner to create a building program that specifies the needs for the building and parameters that should be considered in the design. The architect designs the building to satisfy the program requirements, and then the project engineers design the electrical and mechanical systems and evaluate compliance with energy codes and acceptable levels of environmental comfort. However, because many important architectural decisions are set at this point, few changes can be made that would improve energy performance. Typically, no performance goals are established. The architect and engineers may try to design efficient systems, but they have little interaction or goals to direct the design, so the results are usually mediocre.

In contrast to the traditional building process, the whole-building design process requires the team—the architect, engineers (lighting, electrical, and mechanical), energy and other consultants, and the building's owner and occupants—to work together to set and understand the energy performance goals. The purpose of whole-building design approach is to enable the full design team to interact throughout the design process to fully understand the building systems interdependences. The full design team focuses from the outset on energy and energy cost savings. The process relies heavily on energy simulation, includes design charrettes involving all members of the design team, and establishes energy goals early in the process. The whole-building design process begins with predesign, where often little more than the building size, type, location, and use are known. To be effective, the process must continue through design, construction, and commissioning.

The best time to develop performance targets is at the beginning, before any design concepts have been developed. Once everyone has committed to an energy saving goal, the process can be used to guide the team toward good decision-making and trade-off analysis without sacrificing programmatic requirements. Team members must commit to an energy goal early in the process so they thoroughly understand the interdependencies of the architecture and systems and can create more efficient and cost-effective buildings. To realize low-energy buildings, the project team must not only set a low-energy performance goal, but must *commit* to it. Each member is encouraged to find solutions and offer suggestions that benefit other disciplines, the process, and ultimately the building design.

Whole-building energy simulations guided the designs of all the buildings. Energy simulation in pre-design helps to set quantified goals, and identifies areas with high potential for energy savings and peak reductions. In addition, energy simulations are a crucial tool for understanding the impact of design decisions on energy performance. Experience has shown that the chances of energy analysis affecting the design of a building decrease rapidly as the design proceeds.

During the commissioning and occupancy phases, the design team cooperates to ensure that integrated architectural features such as daylighting, managed solar gains, and engineered building systems are built and function as originally designed. Ideally, once the building is occupied, the design team supports the operators as they learn how the building is intended to operate. Finally, the team must understand how the building operates over time so this and future buildings can realize energy savings over the long term.

The “green” building industry has generally recognized the value of whole-building design. The *Whole Building Design Guide* (NIBS 2006) offers up-to-date tools, design guidance, and technologies related to applying the whole-building design process. Further details of the whole building design process have been previously documented, and are outlined in Table 3-1 (Torcellini 1999).

Table 3-1 Ten-Step Process for Designing and Constructing Low-Energy Buildings

<p>Predesign</p>	<ol style="list-style-type: none"> 1. Set specific and measurable energy performance goals, which may include percent energy savings, percent energy cost savings, and emission reductions. The entire team must understand these goals and how they are affected by design features. Also at this stage, the design team should develop a thorough understanding of the building site, local weather patterns, and building functional requirements. At this point, the design team should brainstorm energy solutions, especially those that affect the architecture. Each building is unique and will have a different minimization strategy. Energy simulation at this stage helps to set quantified goals, and identifies areas with high potential for energy savings and peak reductions. 2. Create a base-case building model to quantify base-case energy use and costs. The base-case building is solar neutral (equal glazing areas on all wall orientations) with equivalent floor area and meets the requirements of applicable energy efficiency codes such as ASHRAE Standard 90.1 (ASHRAE 2004). When building designs and operations change, the baseline has to evolve along with the building under consideration. 3. Complete a parametric analysis of the base-case model to determine sensitivities to specific load components. Sequentially eliminate loads such as conductive losses, lighting loads, solar gains, and plug loads from the base-case building. 4. Develop preliminary design solutions. The design team brainstorms possible solutions, which may include strategies to reduce lighting and cooling loads by incorporating daylighting or to meet heating loads with passive solar heating.
<p>Schematic Design</p>	<ol style="list-style-type: none"> 5. Incorporate preliminary design solutions into a computer model of the proposed building design. The energy impact and cost effectiveness of each variant are determined by comparing the calculated energy performance with the original base-case building and to the other variants. Variants with the most favorable results should be incorporated into the building design. 6. Prepare a preliminary set of construction drawings. These drawings are based on the decisions made in Step 4. Architectural decisions made during the schematic design phase can have the greatest impact on the long-term building energy performance.
<p>Design Development</p>	<ol style="list-style-type: none"> 7. Identify the HVAC system that will meet the predicted loads. The HVAC system should complement the building architecture and exploit the specific climatic characteristics of the site for maximum efficiency. Often, the HVAC system capacity is much less than in a typical building. Verify that baseline and design simulations are updated with design changes.
<p>Construction Documents and Bid</p>	<ol style="list-style-type: none"> 8. Finalize plans and specifications. Ensure that the building plans are properly detailed and that the specifications are accurate. The final design simulation should incorporate all cost-effective features. Savings that exceed 50% from a base-case building are frequently possible with this approach.
<p>Construction</p>	<ol style="list-style-type: none"> 9. Rerun simulations before changes are made to the design during construction. Verify that changes will not adversely affect the building’s energy performance.
<p>Postoccupancy Evaluation</p>	<ol style="list-style-type: none"> 10. Commission all equipment and controls. Educate building operators. Only a properly operated building will meet the original energy efficiency design goals. Building operators must understand how to properly operate the building to maximize its performance. Measure and evaluate actual energy performance to verify design goals were met.

Various styles of the whole-building design process were used to produce the buildings documented in the case studies. For Zion, BigHorn, and TTF, NREL was directly involved in the design process, providing energy analysis and facilitating the design process as it applied to energy performance. The whole-building design process was first documented and tested as part of the TTF design, and then further refined during the Zion and BigHorn designs (Torcellini et al. 1999). Oberlin, Cambria, and CBF each had a design team consisting of energy consultants, architects, engineers, and whole-building design process facilitators. Results from POE of the buildings generated lessons learned and revealed common roadblocks in applying the process.

3.1.1 Owners provide the main motivation for low-energy buildings

The owner was the driving force in each case. The architect, engineer, or energy consultant alone did not provide the impetus for achieving a low-energy building. These low-energy designs required a committed owner who was willing to lead an integrated design process. Each project benefited from an owner who set aggressive goals and made educated decisions to keep the project on track. The owners pushed everyone involved in the design process to meet these goals. The architects and engineers had then to meet the goals and implement the vision. Additionally, the owners in each case were the primary decision makers in the low-energy design process. Dedicated owners made educated design decisions, and architectural and engineering firms were willing to use a whole-building design process to achieve low-energy goals. We can reasonably conclude that future owners and developers will be primary players in the industry and should be targeted with future research and development dollars for low-energy buildings.

3.1.2 Setting measurable goals is crucial to achieve low-energy buildings

The design of most buildings is typically driven by a set of minimum criteria including budget constraints, time scheduling, functionality requirements, safety regulations, and energy codes. This process typically produces buildings that meet *only* these criteria. The design team needs to focus on measurable energy performance goals to achieve better than average or exceptional performance. The goal-setting process should begin as early in the design process as possible for ease of implementation and best results.

Establishing concrete energy goals early enabled the design teams to achieve greater energy savings. Concrete goals provided a true target for the design and a way to evaluate success. Measurable performance goals translate into efficient building performance. Setting such goals enables owners to make decisions that align with the goals. From the outset, all the owners and design teams set aggressive energy-saving goals that ranged from 40% better than code to net-zero energy performance. Some also had ambitious goals about other dimensions of sustainability such as water management, building materials selection, or obtaining a high LEED score.

Effective goals are clearly stated and understood by the design team, construction staff, and occupants, and progress toward them should be measurable. Goals that are not clear and measurable are open to interpretation, which limits their effectiveness. Measuring success requires baselines or benchmarks and performance metrics to quantify the progress. Well-defined performance metrics allow the design team to easily evaluate its success throughout the design and operation of the building (Hitchcock 2003).

3.1.2.1 Goal-setting process

The process starts with a vision statement, such as:

This project will design and construct a building that can be operated to provide a healthy and productive work environment and minimizes the use of nonrenewable material and energy resources in a cost-effective manner.

The vision statement should be used throughout the life of the building to help guide key decisions about material selection, design, and system operation and maintenance. It is a broad declaration about the final performance, which should be broken down into topic areas that can be implemented by the design team and later used by the operators to assess performance. For example, the above vision statement can be divided into the following areas: *environmental loading*, *economics*, *service quality*, and *occupant health and safety*. Each topic area should be further divided into subtopics. Examples of topic and subtopic areas are shown in Figure 3-1. The *Whole-Building Design Guide* (NIBS 2006) provides another example of dividing building performance into eight “objective areas” with further division into subtopic areas.

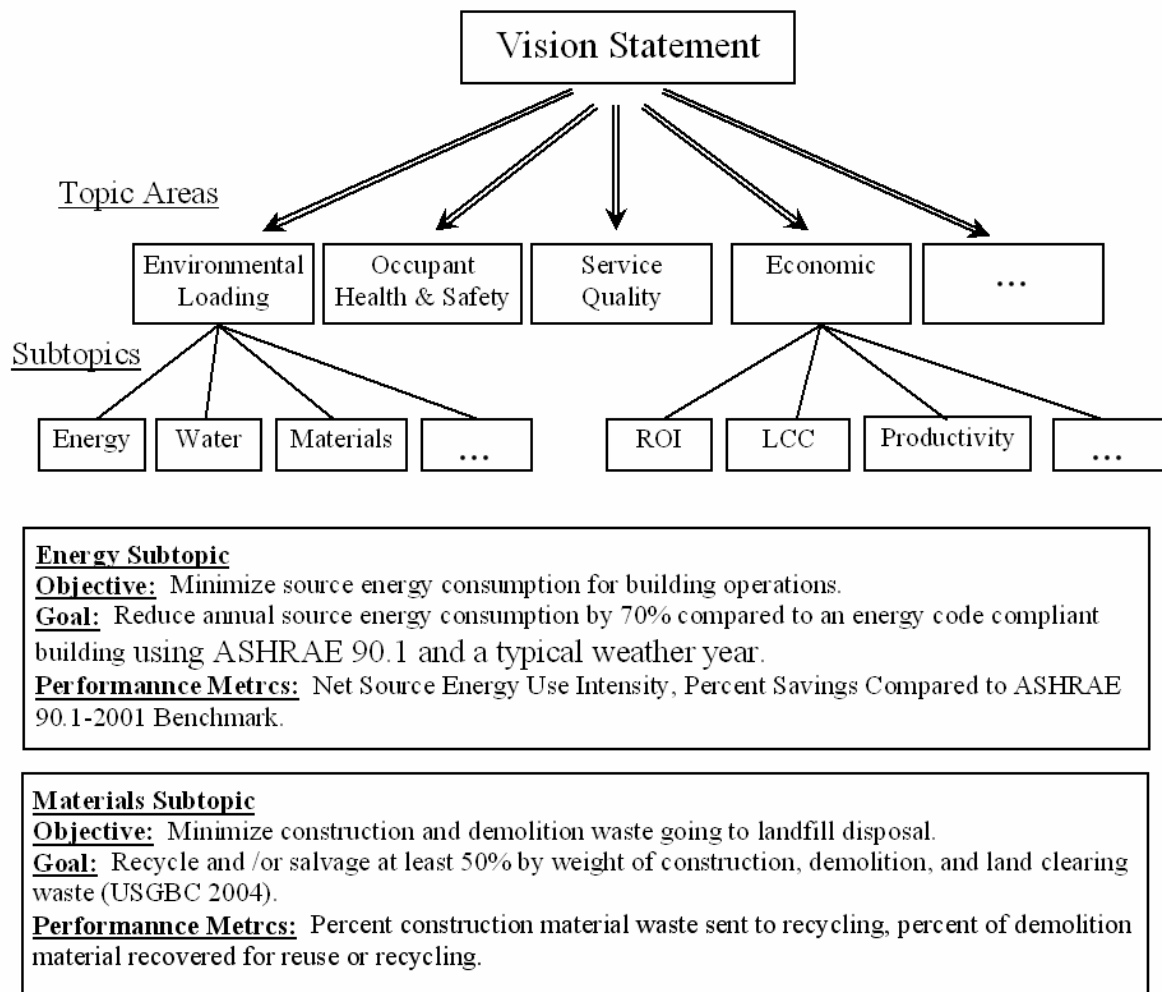

Figure 3-1 Schematic of the performance-based design process

Creating a single goal across topic areas is difficult. For example, water and energy use cannot be aggregated into a single value. However, financial comparisons, such as the costs of water and energy, can be made. The LEED rating system uses implicit weighting factors to combine the subtopic areas into a single performance indicator (USGBC 2004). Other tools such as GBTool and MCDM-23 rely on user-selected weighting criteria to combine subtopic metrics into aggregate performance indicators (iiSBE 2000, IEA 2002).

The next step in the goal-setting process is to define objectives—general statements about the desired outcome—for each subtopic area. Specific goals are then developed from these statements. Developing

goals is often an iterative process during the conceptual design phase. Setting realistic goals involves engineering and economic analysis to determine what is possible and how much it will cost.

Once the goals are established, the design team can identify obstacles and find solutions. This process can include computer simulations, consultations with technical experts, communications with product manufacturers, and research into similar projects. The goal-setting process can be summarized as follows:

1. Develop a vision statement as a guide for design, construction, and operation.
2. Divide the vision statement into topic and subtopic areas to address specific details.
3. Define the objectives for each subtopic area.
4. Establish clear and measurable goals (may be an iterative process).
5. Define performance metrics to measure the progress toward achieving the goals.
6. Develop and carry out a plan for monitoring performance throughout the design and operation of the building.

The final, most important step requires the most effort and is often not carried out completely. If the performance is not verified, there is no way to know whether the goals are satisfied or how the building is performing. The monitoring plan should specify responsible parties and reporting requirements. The basic tenet behind this design process is that “you get what you ask for.” When a clear vision of the desired outcome is broken down into objectives and goals, there is a greater chance for producing a high-performance building.

3.1.2.2 Buildings performance driven by design goals

An important lesson learned from these projects is that performance is driven by design goals (Deru and Torcellini 2004). The design performance goals and measured building performance of the six projects are summarized in Figure 3-2 and Table 3-2.

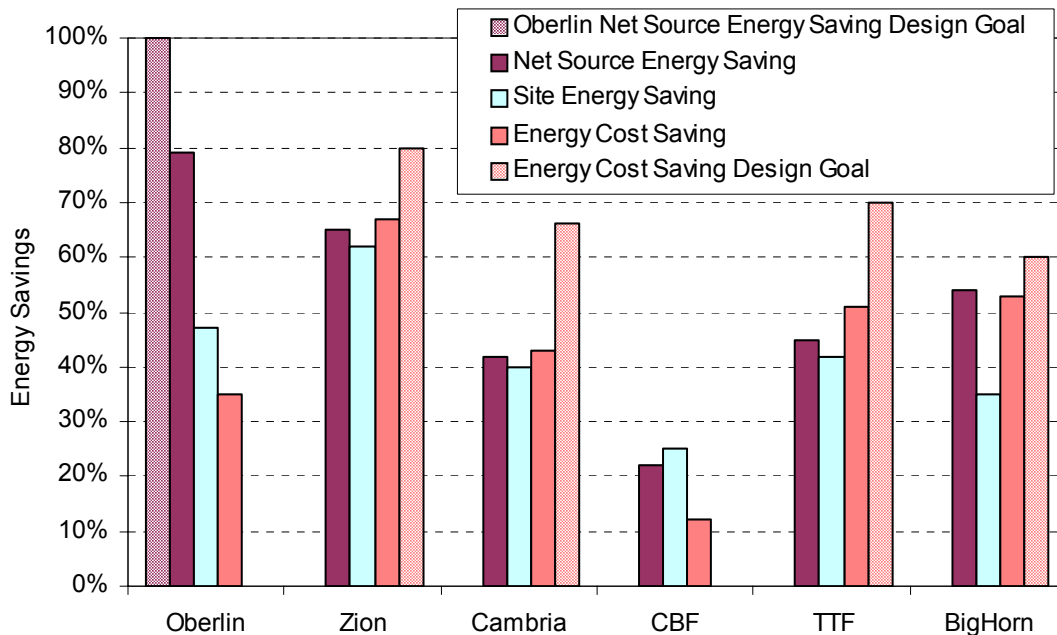





Figure 3-2 Energy savings compared to design goals

Note: PV production is included in the energy savings numbers, except for site energy savings.

Table 3-2 Performance Goals and Measured Performance

Building	Performance Goals	Performance Category				
		Net Energy Cost	Net Energy Use	Water Use	Material Selection	Site Impact
Oberlin	Net zero energy building	☀	☀	☀	☀	☀
Zion	70% energy cost saving	☀	☀	☀	☀	☀
Cambria	LEED Gold, 66% energy cost saving, 33% water saving, material selection, low site impact	☀	☀	☀	☀	☀
CBF	LEED Platinum, 50% energy cost saving, low water consumption, material selection, low site impact	☀	☀	☀	☀	☀
TTF	70% energy cost saving	☀	☀	☀	☀	☀
BigHorn	60% energy cost saving, reduce site impact	☀	☀	☀	☀	☀

 High Performance (50% or greater savings)
  Better Performance (20% to 49% savings)
  Standard Performance (0% to 19% savings)

Note: Water use, material selection, and site impact metrics were not evaluated in the separate case studies; these performance categories were evaluated based on design documents and/or LEED submittals.

All the buildings had aggressive energy saving goals, and each performs well with respect to the design goals. Three saved more than 50% in energy costs; Oberlin and Cambria saved less than 50% in energy costs. Cambria and CBF had aggressive water use reduction goals that strongly influenced the design process and goals for materials selection, which guided the selection of materials considered sustainable within the LEED framework. However, studies indicate that buildings that earn more LEED credits do not necessarily provide more environmental benefits than those that earn fewer credits (Stein and Reiss 2004). The United States Green Building Council (USGBC) is currently researching life-cycle assessment methods to enhance the LEED rating system to account for long-term energy and environmental impacts over the life of the building.

A building that meets its goals might not fare as well compared to other buildings that used other metrics for goals. Each building performs with varying levels of success, depending on the metric the owner uses. As an example, CBF had a goal of constructing a LEED 1.0 Platinum building. It met this goal; however, energy was not a primary goal. The building is a good energy performer, but its energy use is greater than that of some of the other buildings. Oberlin had the most aggressive energy goal, which is evident in the results, but did not do as well in the energy cost category (which was not its goal). Oberlin’s goal was a net-zero energy building, which would result in 100% net source energy savings and 100% net site energy savings. The building was not designed for high energy cost savings, which is shown in Figure 3-2. Figure 3-2 shows that the selecting site, source, or energy cost as a design goal can greatly affect the performance of the building. The design goals are also evident in the management philosophy. For example, Oberlin does not aggressively manage demand, and the large PV system does not reduce the substantial demand charges that affect overall costs. Zion is at the other end of the scale with few demand charges.

The design teams for Zion, TTF, BigHorn, and Oberlin established low energy as a priority at the outset. As shown in Figure 3-2, these aggressive energy goals produced buildings with excellent energy performance. In general, each building performs well in the areas that had clear goals set from the beginning of the design process. The performance in the other sustainability areas is slightly better than standard practice. These projects show that defining specific goals helps the design team achieve better results.

3.1.3 Cost justification of integrated design

Building owners make decisions based on values. Quite often they pay for features—especially architectural ones—they really want. Conversely, if an owner does not want a feature, cost is often used as the reason to eliminate it. In addition to energy cost savings, cost effectiveness should be expanded to include marketability of a green building, image, disaster resistance (for example, the ability to function if no grid power is available), and other value-added features. Each case study can justify low-energy solutions by means other than standard payback techniques. Regardless of the criteria for making decisions, all team members must understand the goals. The best way to reduce the cost of low-energy features and ensure successful integration is to incorporate them into the architecture early. If low-energy features such as daylighting clerestories or cooltowers can be integrated into the architectural statement, they can be included as part of the architecture costs.

The cost of low-energy features can be reduced by using the architectural design and envelope to save energy and enhance comfort. Architectural features such as form, shading, space layout, envelope constructions, materials, sizing, orientation, and glass all have significant impacts on energy, lighting, and comfort. The total cost to construct the Zion Visitor Center was less than originally budgeted. Integrating energy features into the envelope at Zion increased total envelope cost; however, reducing infrastructure and mechanical systems (which included eliminating the mechanical room and duct work) reduced costs.

Low-energy buildings often defy industry norms for equipment sizing, such as ft²/ton. Lower loads resulting in downsized equipment can substantially reduce construction cost and the savings can often be used to pay for other energy features. There will be some trade-off during the design process between mechanical system decisions and architectural features. Although the energy design process may increase costs to design the building compared to the traditional design process, the increased cost is often offset by a reduction in errors and decreased mechanical system cost. Fewer errors occur because careful attention was paid throughout the design process and more emphasis is placed on checking and review. In addition, small mechanical systems require less space in the building, which reduces construction costs. The best example of this was at BigHorn. Internal gains were reduced by integrating daylighting, enhanced insulation, and natural ventilation into the envelope design. This eliminated the need for a conventional air-conditioning system.

The BigHorn owners have successfully marketed the green image of the building to offset additional project costs. The construction costs were approximately 10% higher than for a conventional building. Some were energy related, but these were an integral part of the architectural image. Anecdotal evidence suggests that increased costs for low-energy features have been offset by increased customer traffic. The project received significant press coverage as the first low-energy hardware store in the area. This publicity increased customer traffic at the old store, even before the new “green” hardware store was constructed. The low-energy design has become a value-added feature, as it resulted in free advertising for BigHorn.

At Zion, low-energy features are integrated into the high-value UPS. National Park Service staff members were concerned about the unreliable power at the park. A UPS was included in the original plan for the electrical system, which was designed to allow a grid-tied PV system to offset energy use and provide battery charging capacity during power outages. The PV-integrated UPS circuit allows the building to remain operational during daylight hours when no power is available by providing power to

the computer equipment, cash registers, window actuators, cooltower pumps, telephone switch, and BAS. The daylighting system provides enough light during most typical business hours. This value-added system allows the Visitor Center to continue normal business activities in a comfortable, lit space during the frequent power outages when every other business in the area is inoperable.

Another value-added feature at Zion is the cooltowers. Most cooling systems are hidden and designed to be inconspicuous, but visitors to Zion congregate around the cool air outlets. They find the towers fascinating and give them the type of attention often given to large fireplaces in public areas. This interaction provides an unexpected amenity that a traditional cooling system would not.

3.1.3.1 Construction costs

This set of low-energy buildings represents a wide range of building types in different climates, at varying construction costs. Construction costs ranged from \$93/ft² (\$1,001/m²) to more than \$400/ft² (\$4,306/m²), primarily because of programmatic requirements. The higher cost buildings such as Zion and Oberlin were more expensive—not solely because of energy features, but because of project requirements such as long life, high durability, or specialized laboratory spaces. In many “green” buildings, other architectural elements add to the cost, and separating architectural amenities from the “green” elements is difficult.

At a construction cost of \$93/ft² (\$1,001/m²), the Cambria office building shows that extra attention can be paid to systems and materials to build a “green” office building within the same cost range as a conventionally constructed one. The building is economically viable in this location, as it was developed by a private developer who was looking for a good return on investment. This kept the costs in check.

Experience with the TTF project showed that a low-energy commercial building can be constructed within the constraints of a fixed budget. Although construction analysis shows a 3.9% increase in costs directly related to energy efficiency improvements, the costs would probably have reached the maximum allowed under the fixed budget had the building been built without regard for energy consumption. The TTF represents an economically practical approach to achieving high performance, with construction costs at \$119/ft² (1995 dollars) (\$1,281/m²) and 52% energy cost savings.

3.1.4 Using energy modeling throughout process

Whole-building energy simulations guided the designs of all the buildings. Energy simulation in pre-design helped to set measurable goals, and identified areas with high potential for energy savings and peak reductions. The design team used energy models to determine the minimum energy targets, incorporate the climate and the program goals, evaluate envelope options and architectural designs, and design mechanical systems that matched the predicted loads. Finally, NREL used simulations to evaluate postoccupancy performance and verify design goals. Simulation tools used for design analysis and POEs for these buildings included DOE-2.1E, DOE-2.2, and EnergyPlus.

The energy use and costs of a building depend on the complex interaction of many parameters and variables. The problem is far too complex for rules of thumb or hand calculations. Computerized energy simulation software can thoroughly evaluate all interactions between the envelope, HVAC system, and design features. The best time to develop performance targets is at the beginning, before any design concepts have been developed, because energy analysis affects design less and less as the design proceeds. Yet energy analysis, if done at all, typically starts about the time of design development and is typically used for code compliance or selection of HVAC type—not for designing the building envelope.

An “elimination” parametric analysis helps designers understand the sensitivity of total energy performance at specific loads. A parametric analysis is performed by eliminating loads—conduction losses, people, solar gains, and plug loads—one at a time from the simulation. As loads are eliminated, the designer determines their impact on the total energy performance by comparing energy use with and without each load. For example, if eliminating all conductive heat transfer through the envelope has little

effect on energy consumption and energy costs, there would be little reason to increase insulation levels to exceed code. Similarly, the exercise may demonstrate an upper limit to the amount of insulation before internal loads begin to increase cooling loads. The design team may discover that finding an optimal insulation level allows money otherwise spent on additional insulation to be used elsewhere, with a greater impact on the total energy picture. If, however, eliminating all solar gains greatly affects energy performance, solar-related issues such as window area, orientation, window solar heat gain coefficient, and facade shading geometry (such as window overhangs) are worth exploring. An energy goal for the climate and building type should be established based on this analysis, and all team members should agree on its feasibility.

In all cases, energy simulations played an important part in understanding the forces that drive energy performance and allowed many design alternatives to be investigated. At BigHorn, additional windows were added that vastly improved daylighting in the building. At the TTF, clerestory heights and overhangs were optimized, minimizing cooling loads while maximizing daylighting.

3.1.4.1 Setting energy baselines in the low-energy design process

A standard performance metric for low-energy buildings is often percent savings. The first problem with this is determining the baseline or reference point for comparison. Most often, baselines are based on a comparable code-compliant building. For the six buildings studied, the design predictions used baselines that included ASHRAE 90.1-1989 (ASHRAE 1989), 1999 (ASHRAE 1999), 2001 (ASHRAE 2001), and 10 CFR 435 (DOE 1995). For consistency among the case studies, actual energy savings were determined for most of the buildings in comparison with ASHRAE 90.1-2001.

An essential element of the case studies has been defining and analyzing baseline models that are used to determine energy and energy cost savings. We used baselines to analyze energy performance for buildings from predesign stages to postoccupancy as-built buildings. When building designs and operations change, the baseline has to evolve along with the building under consideration.

Three classifications of baselines were used depending on the design progress and purpose of the baseline (see Table 3-3). The baseline classifications used include:

- **The Predesign Baseline** is used in the initial stages of the low-energy design process. This is a theoretical building based on basic information known about a proposed building in the pre-design phase. Basic inputs of building function, size, and location are used to define the predesign baseline, which is then used to estimate annual loads and peak electrical demands for heating, cooling, lighting, plug loads, and HVAC system fans and pumps. In general terms, a pre-design baseline building is “solar neutral.” For a typical commercial building, a predesign baseline design is a rectangular floor plan with an aspect ratio of 1.75 that uses a simplified zoning scheme with windows distributed equally at all four cardinal orientations. An “elimination” parametric analysis is performed to help building designers understand the driving forces and sensitivities of energy performance and energy costs in the climate under consideration.
- **A Proposed Design Baseline** is used to determine the energy performance of a building during the design process. It represents a minimally code-compliant version of the proposed design. When the design of the proposed building has progressed to the point where floor plan, layout, and other physical fabric characteristics have been determined, the proposed design baseline is modeled in four orientations by rotating the baseline model 90° four times, and then averaging the results. This baseline includes features of the building design such as location, size, footprint, building use, fuel types, and expected schedules. Appendix G of ASHRAE 90.1-2004 provides a method for determining the annual energy performance of a proposed design baseline along with the proposed design (ASHRAE 2004).
- **The Existing Building Baseline** can be used to evaluate the energy performance of existing buildings. The need to verify design goals during occupancy is increasing, especially for the current

generation of low-energy commercial buildings. Often, the as-built building has significantly different physical and operational characteristics than the building design. Thus, the baseline comparison for the existing building must be updated to reflect actual operation during typical occupancy. Assumptions made for the design baseline, such as occupancy schedules, equipment loads, weather, and set points, are measured in the existing building and included in the existing building baseline. Further evaluation techniques for existing buildings are discussed in Section 3.7.

Table 3-3 Baseline use in the low-energy design process

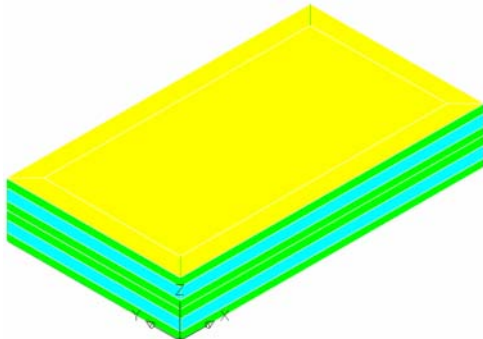
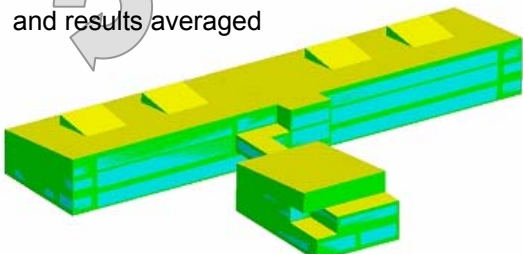
Rendering of Baseline Models	Design Process	Baseline Use
 <p>Solar Neutral Predesign Baseline</p>	<p>Predesign and Programming</p>	<ul style="list-style-type: none"> • To develop an understanding of the building site, local climate, and functional requirements. • To help set measurable design goals that are reasonable and attainable. • To complete a parametric analysis to determine sensitivities to specific load components.
<p>Rotated four times and results averaged</p>  <p>Proposed Design Baseline and Existing Building Baseline</p>	<p>Schematic Design</p> <p>Design Development</p> <p>Construction Documents</p> <p>Construction</p> <p>Occupancy</p>	<ul style="list-style-type: none"> • To evaluate preliminary design solutions. Energy and cost effectiveness of each energy design feature is determined by comparing the proposed design to the Proposed Design Baseline. • To determine predicted savings of the finalized design, which incorporates all energy saving features to be included in the construction documents. • To ensure changes made during construction do not adversely affect the energy performance. • To verify the existing building meets the design goals.

3.1.4.2 Modeling in postoccupancy evaluations

Whole-building energy performance modeling was essential for determining energy savings and developing recommendations to address identified problems. To calculate the energy savings of a building, a model must be calibrated against actual building data. In most cases, too many changes occurred from design to occupancy to use the design-based models as accurate predictors of energy consumption. Schedules and plug loads vary widely from original assumptions. The base-case model must be modified to reflect the as-built schedules and plug loads. A calibrated as-built simulation compared to a conventional base case can provide a confident prediction of annual site, source, and cost

savings. Using typical meteorological year weather data allows long-term savings calculations with relatively short-term data.

Energy saving uncertainties can be minimized when savings are determined from the comparison of one simulation to another (e.g., base-case to as-built). Because difficult-to-know inputs are held the same in both simulations, such comparisons remove much of the uncertainty inherent in an hourly building energy simulation. Variables that change throughout the year, such as inconsistent occupancy, set point changes, and equipment performance degradation, are difficult to account for in an annual building energy simulation. Comparing a base-case model to an as-built model with the same schedules reduces the uncertainty. Further lessons learned in using simulations for design and evaluation purposes are discussed in Section 3.7.

3.1.5 Common roadblocks to successful integrated design process implementation

Various styles of the whole-building design process were used to produce each building documented in NREL's case studies. For Zion, BigHorn, and TTF, NREL was directly involved in the design process, providing energy analysis and facilitating the design process as it applied to energy performance. Results from each POE performed by NREL provided lessons learned and common roadblocks in applying the process.

3.1.5.1 The energy models are not updated as design development progresses

The simulations from predesign through occupancy must be maintained. Important changes to the design and siting of the Zion Visitor Center occurred late in the design development stage. Changes to the locations and orientations of offices reduced energy performance. For example, offices were located adjacent to the Trombe wall and far from the cooltowers, which caused localized comfort problems. In addition, cooltowers were removed. Had each design change been reanalyzed with detailed simulations and updated thermal zoning, the comfort problems may have been identified and corrected (e.g., by adding cooltowers that had been removed back into the design or moving the offices).

3.1.5.2 Energy features are incorrectly installed

We uncovered many examples of design features that were missing, installed incorrectly, or a lower quality product substituted. For example, the TTF foundation was missing insulation that designers specified. Perimeter slab insulation was specified on the inside of the foundation for ease of installation; however, this was not installed during construction. By the time it was discovered, adding it would have been too costly. As a result, a 6-in. (15-cm) thermal bridge around the perimeter of the concrete slab affects occupant comfort. We also determined that the construction team did not install the window and door frame thermal breaks as specified. The reasons are unclear for the error, but there are increased thermal losses. Door and window frames must be carefully specified with resistance values, and construction management must have a mechanism for evaluating such products in the field to ensure they are installed according to design.

At Zion, the electrical lighting circuiting was not installed as designed, which limited the daylighting control strategy. The stepped daylighting controls have been problematic, as the stepped control resulted in uneven distribution and occupant complaints of on-off sequencing. The design of the stepped operation called for every other fixture to be on a separate circuit. Instead, every other row was installed on a separate circuit, which resulted in uneven light distribution during stepped control operation.

Inspecting buildings with vigilant field verification of how the building is constructed with a concern for the building's energy features can help to ensure that intended energy features are actually included in the building. An understanding of how the building differs from its design can be invaluable in assessing the reasons why the building displays a certain level of performance. In the case of TTF, knowing that proper foundation perimeter insulation was not installed helped designers understand how envelope heat losses could affect heating and comfort conditions.

3.1.5.3 Problems simulating innovative features in an integrated whole-building model

A common limitation of the simulation tools was calculating energy costs. This was most evident when we tried to assess the impact of PV. To fully realize the cost implications in commercial buildings, PV must be integrated into the simulation engine to fully determine whether any demand savings are achieved. By using a simulation tool that models energy use, PV production, and peak demand on a 15-minute time step, we can research and develop demand-responsive controls that enable on-site PV production to reduce peak demand and optimize energy costs. Neither DOE-2.1E nor DOE-2.2 can model PV power production directly.

In the analysis of Zion, uncertainties with Trombe wall thermal models, difficulties modeling the as-built operation of subhourly demand-responsive controls with integrated PV production, and lack of building-integrated modeling techniques for the energy use and cooling capacity of cooltowers prevented the simulation of an as-built model of the Visitor Center and Comfort Station. With capabilities available today in EnergyPlus, models could be developed for further study of demand-responsive controls with on-site generation, water use in evaporative cooling systems, and enable an as-built to base-case simulation comparison for determining energy and cost savings (EnergyPlus 2005). These capabilities also enable a more realistic prediction of peak demands, which can be greater than 50% of the total energy costs.

3.1.6 Measured versus predicted performance

Comparing the measured performance to the design phase predicted performance is useful to the designers and energy researchers. The designers want to know how well the energy-efficient design features perform so they can design better buildings. The energy researchers are interested in how well the energy-efficient features perform and want to know how well the energy simulations can predict performance. Our experience with the low-energy buildings shows a disconnect between actual buildings and the simulated predictions. We have observed that real buildings, when compared to the design simulations, use more energy, produce less power with the PV system, and have worse controls.

All six buildings used more energy and produced less energy than the design simulations predicted. Often this is due to the assumptions made in the simulations on building operation and schedules. These always vary from actual building operation. Simulations create idealistic controls—actual performance showed different set points and less setup and setback of space temperatures. Another reason is the lack of innovative controls for the innovative technologies. Appropriate control systems can successfully integrate the low-energy technologies and allow a building to operate at its design potential. The key is to maintain controls that function in harmony with building design intent.

Another problem is that many energy-saving technologies have backups, so when they fail, there is no motivation to maintain the technologies or even verify their operation. Examples include natural ventilation and CO₂ sensors at Oberlin that are not used, a desiccant heat recovery system at CBF that is not used, daylighting controls that are improperly used in some cases (lights are on when daylighting provides enough light). Additionally, PV systems were down for months at a time at Cambria and BigHorn because occupants were unaware of system status. See Section 3.4 for further discussion of performance degradation in PV systems. When these systems fail, detailed monitoring is required to detect the failures and ensure proper operation.

Even though each building is a good performer, the energy performance was less than expected during design. Design teams were a bit too optimistic about the behavior of the occupants and their acceptance of systems. Energy consumption was higher and energy production was lower than simulations predicted. In particular, daylighting saving was less than predicted, which meant more electrical lighting was used. See Section 3.2 for a discussion of daylighting energy savings.

In addition, plug loads were often greater than design predictions. The results from the CBF analysis indicate that the performance predictions made during design development were too optimistic, primarily from underestimating the amount of electricity drawn by plug loads. Plug and miscellaneous loads were

twice those assumed for the predictions. Underestimated loads included information technology equipment in the offices and server room and miscellaneous loads such as exterior lighting, mechanical room accessories, and the elevator. At BigHorn, a major omission in the design model was the lighting display area. During the design the lighting display area was not expected to be a large load; however, the installed display lights increased over time as light fixtures became large sale items. These data are hard to obtain in advance and need to be assumed for design. Efforts to improve the accuracy of predictions of whole-building energy performance during the design phase should focus on better methods of developing assumptions for receptacle and miscellaneous electrical loads.

Total insulation values are often inflated during building design. Thermal bridging was partially accounted for in the models during the design process, but it is often an optimistic value compared to actual construction techniques. For example, the thermally broken window frames were not installed at TTF. In all the buildings, thermography indicated thermal leaks, especially at corners and areas where the building touches the ground—very difficult areas to insulate. In one case, a retaining wall was attached to the building for structural integrity and acted as a fin, reducing the integrity of the thermal envelope. These results are similar to those found by other researchers (Branco 2004, Norford 1994).

3.1.6.1 Update design simulations from predesign through occupancy to ensure the design simulations will measure up to actual performance

For Zion, an energy cost-saving goal of 70% was set at the beginning of the design process and used as an energy saving target throughout the process. Computer simulations showed that an energy saving goal of 80% was achievable. However, actual measured data indicated that the building energy cost saving was 67% because some construction and design changes were made before we could perform energy simulations to determine their energy impacts. Partway through the design development process step, the building site changed. The entrance to the building was relocated to the north side to facilitate pedestrian flow through the Visitor Center Complex, which allowed the south facade to be unobstructed and increase passive solar gains. The offices and break room were moved to the south side of the building, adjacent to the Trombe wall and far from the cooltowers. The number of cooltowers was reduced to three, two for the Visitor Center and one for the Comfort Station. The building engineer concluded that there would be enough airflow with fewer towers. For architectural reasons, the amount of north and west glass increased, although the tree canopy and building shading keep these surfaces shaded most of the summer. Finally, the outdoor cooltower was removed, so the two cooltowers were expected to condition inside and outside spaces. Had each design change been reanalyzed with detailed simulations and updated zoning, negative energy impacts may have been predicted and corrected. In addition, the design simulations would have more closely matched actual performance. The simulations must be maintained from predesign through occupancy to ensure the actual performance will match the design simulations and the energy goal.

3.1.7 Monitoring leads to better management and improved performance

Setting and following design goals does not guarantee that the goals will be satisfied in actual operations. The performance must still be tracked and verified. Many items were corrected because of the information gained through monitoring. The key is to maintain controls that function in harmony with building design intent. A good building quickly becomes a “bad” building with poor control strategies. Commissioning a new building is essential, but ensures only that the building components operate as specified. All six of these low-energy buildings were commissioned, formally or informally, before occupancy. Various degrees of continuous commissioning occurred during the postoccupancy monitoring as well. In general, the traditional commissioning process did not translate to expected energy savings, as we still found significant deficiencies.

Continual monitoring of energy performance, or continuous commissioning with key energy-saving performance metrics, is important to ensure that the goals of the design are met under normal operating conditions. In all the buildings, adjustments in controls, equipment, and operation were made to better

align the performance with the design goals. Oberlin was a dramatic example of improved energy performance because of better information obtained from monitoring. Monitoring at Oberlin resulted in controls and equipment changes that reduced initial site energy use by 37%, from 47.5 to 29.8 kBtu/ft² (539 to 338 MJ/m²). The improvement in performance, shown in Figure 3-3, was due to correcting problem areas identified by the metering. Metering started in March 2001, reducing the initial excessive energy use as shown by the utility bills.

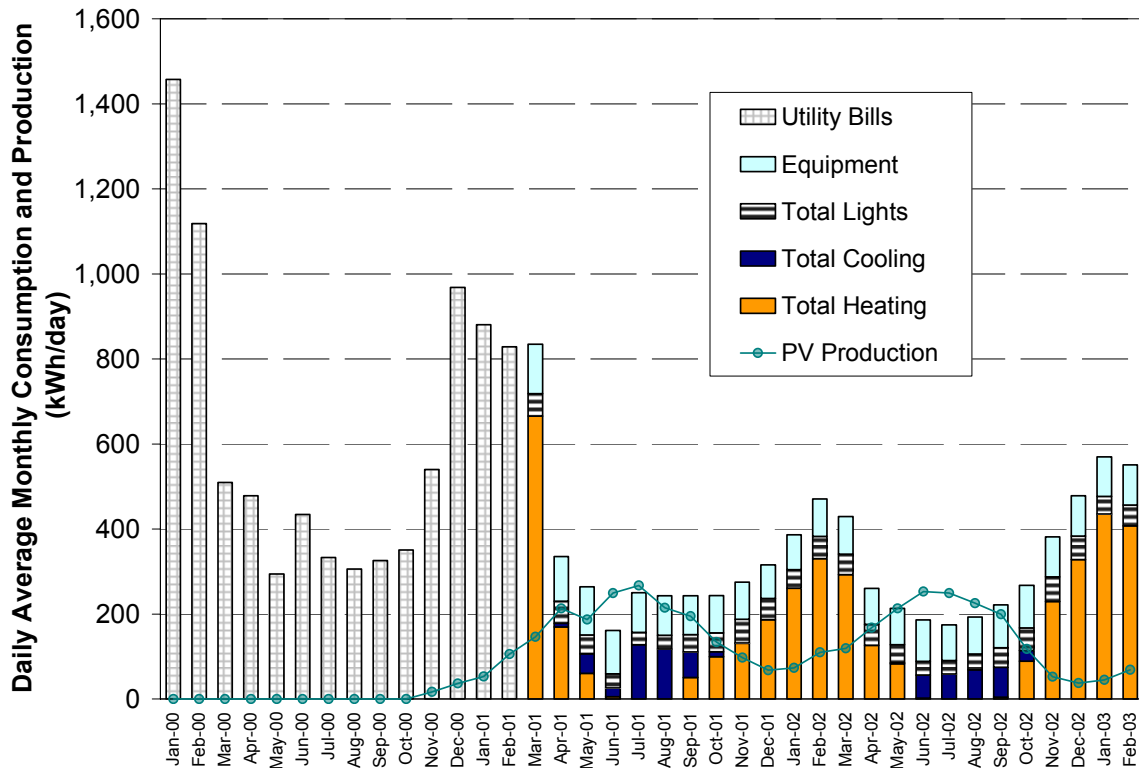

Figure 3-3 Oberlin monthly site energy use and production, January 2000–February 2003

Achieving and maintaining a high-performance building requires a continual and concerted effort, which is absent in most buildings. Continually tracking building performance is expensive and requires a motivated staff. However, advances in metering technology, computerized communications, and automated controls are reducing the costs of monitoring building performance. Additional research is needed to further reduce costs, better optimize control strategies, and improve reliability to realize the full energy savings potential of high-performance buildings.

3.2 Lighting and Daylighting Systems

Lighting uses 30% of the total energy in commercial buildings, making it the largest single end use. From a national perspective, the potential for daylighting savings is significant. Based on the Commercial Building Energy Consumption Survey (CBECS) data set (EIA 2005a), nearly 80% of all commercial building floor area has an exterior ceiling or is within 15 ft (4.6 m) of an exterior wall, and therefore has the potential to be daylit. (See Appendix B for further discussion on determining the national daylighting potential in commercial buildings with the CBECS database.) Through toplit or sidelit daylighting designs, daylighting could be provided to a significant portion of the total floor area in the commercial building sector. With just toplit daylighting designs, 60% of all commercial buildings floor area has daylighting potential. Thus, lessons learned about applying daylighting design and controls to minimize lighting energy use are valuable to the industry and to future ZEB designs.

We believe daylighting is critical to high performance in buildings. All six buildings feature daylighting design, and all have experienced problems. Some lacked energy savings, experienced unacceptable glare, or had lower than anticipated lighting levels. Daylighting is a classic systems integration challenge; if five of the six elements necessary to good daylighting are done correctly, but one is not, energy savings may not result. Glazing and good lighting design are necessary, but are not enough to save substantial energy. Good daylighting can offer dramatic electrical energy savings benefits. Daylighting was the best resource for total energy savings at Zion, Oberlin, BigHorn, and TTF.

Each daylighting and lighting system was evaluated as part of the POE. In each case, equipment or operational changes were made to the daylighting systems to increase energy savings and lighting quality. The goals of the daylighting evaluations in the case studies were to:

- Determine the amount of electrical lighting offset by lighting design, daylighting, and occupancy controls compared to the baseline.
- Analyze the operation of the lighting and daylighting controls and optimize their performance.
- Document successes and weaknesses of the daylighting and lighting systems to expand the knowledge base in this area.

The evaluation team performed an annual daylighting analysis based on a monitoring protocol developed by the International Energy Agency Solar Heating and Cooling Programme (IEA/SHC) Task 21 (Atif 1997). This protocol offers guidelines for measuring daylighting performance, predicting performance, and evaluating control parameters. The performance measurement section of this protocol outlines recommended techniques for monitoring the daylighting contribution to indoor illuminance and the corresponding electrical lighting displacement. Per the daylighting analysis protocol, we measured horizontal illuminance in selected daylit zones during varying sky conditions for typical summer, winter, and fall/spring seasons. Recommended illuminance levels for each lighting zone were analyzed in accordance with the *Lighting Handbook of the Illuminating Engineering Society of North America* (IESNA 2000). External horizontal illuminance and electrical lighting consumption must be simultaneously monitored to complete the daylighting measurements.

3.2.1 Daylighting designs

Toplit daylighting through clerestories and high windows is integral to each daylighting system. The daylighting design of all the buildings used clerestories, elongated east-west axes, and south glazing. South-facing clerestories are the primary sources of daylighting at Zion, Cambria, the BigHorn retail zones, and TTF (Figure 3-4), with some sidelit contribution. Sidelit daylighting is the primary daylighting source at CBF and Oberlin; north-facing clerestories are used for daylighting-specific zones.



Figure 3-4 TTF daylighting with clerestory

Daylighting is provided in the BigHorn warehouse primarily through skylights (insulated translucent glazing panels) along the ridgeline (Figure 3-5). One large dormer, two smaller dormers, and small windows on the south and east walls provide additional natural lighting to the warehouse space.



Figure 3-5 Translucent skylights in the roof of the BigHorn warehouse

The warehouse daylighting design is very effective, as it requires no electric lights during most of the daylight hours. The translucent skylights work well in this application where lighting is more important than the thermal issues of overheating in the summer and heat loss in the winter. This space was not cooled and only minimally heated. Daylighting strategies in the BigHorn retail area include north- and south-facing clerestory windows that run the length of the store; three dormer windows on the north side; high windows on the east and west ends; and a borrow window from the warehouse. The walls, floor, and vaulted ceiling of the retail area were painted white to distribute the daylight and make the space look brighter.

Cambria's east-west orientation is an important part of its daylighting system. Virtually all fenestration faces either north or south. The second floor is primarily open office plan and houses most of building occupants. Clerestory windows face north and south along the center of the building. The south-facing

clerestory windows are equipped with motorized sunscreens controlled by a photosensor to block direct-beam radiation. Overhangs shade the second-floor windows on the south elevation. Light shelves are installed on the south-facing first-floor windows. These light shelves, combined with shading devices, help reflect the light to the ceiling plane and minimize direct gain through the view glass (see Figure 3-6). The interior finishes were selected to improve the light reflection and provide contrast. The first floor ceiling tiles have a light reflectance of 89%, the second floor has high vaulted white ceilings with an open truss construction, the bottom 2.5 ft (0.8 m) of the walls are a light, natural wood color, the top portion of the walls are painted off-white (light reflectance of 75%), and the cubicle dividers are off-white. The carpets and desktops are black (see Figure 3-7).



Figure 3-6 Cambria first floor light shelves



Figure 3-7 Cambria second floor clerestory showing dark floors and high vaulted white ceilings with an open truss

A combination of electric lighting and daylight illuminate TTF. The amount of electric light provided at any time depends on occupancy and the availability of daylight. The building's clerestory or stair-stepped design is integral to the lighting plan. Daylight enters the building through a row of windows that line the south facade of the open office areas and two additional rows of clerestory windows in the mid- and high-bays. To provide some bidirectional light, six 2.5-ft by 2.5-ft (0.76-m by 0.76-m) north windows are located in the high-bay. In addition, the service core south wall allows for reflection of mid-bay clerestory light into the office (low-bay) area. All windows were specified to maximize daylighting transmittance. NREL selected clerestory windows with a high visible transmittance of 72%. View glass windows in the open office area and conference room were chosen with a slightly gray tint with a visible transmittance of 38% to reduce glare.

As shown in Figure 3-8, the primary source of light at Zion is daylight that enters through clerestory windows and a strip of windows high on the walls. Electric lighting provides additional light. We selected T-8 lights for most of the main open floor areas, with fixtures that are 88% indirect with 11% direct.



Figure 3-8 Zion daylighting with fixtures that are 88% indirect and 11% direct

At Oberlin, we calculated the percentage of daytime hours when daylighting alone could provide all the required illuminance (according to IESNA recommendations) to various spaces. The classrooms, shown in Figure 3-9, could be completely daylit for 52% to 73% of the daytime hours, depending on seasonal differences in available daylight and solar angles. The corridors and offices could be completely daylit for 83% of the daytime hours over a year. Figure 3-10 shows the northern clerestory windows and second-floor office windows.



Figure 3-9 Oberlin second-floor daylit classroom

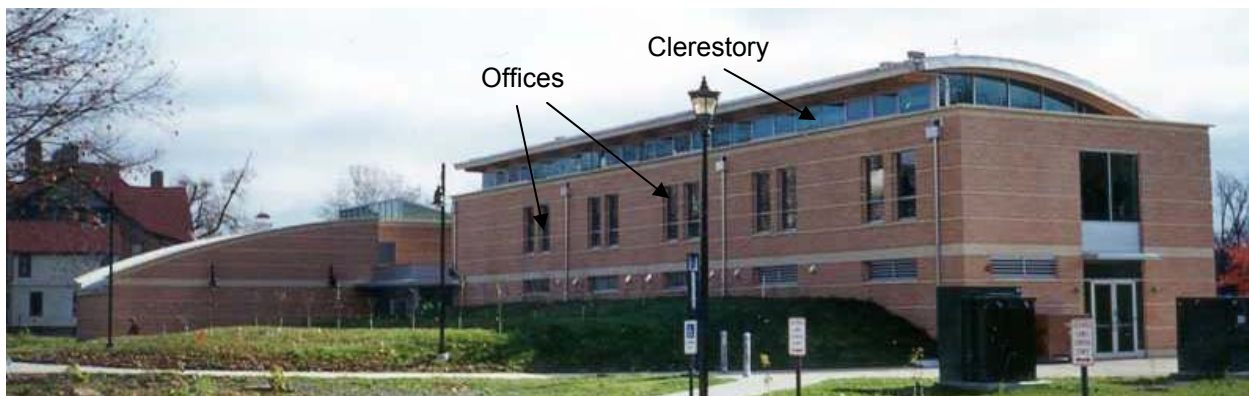

Figure 3-10 Oberlin north facade

3.2.2 Daylighting and lighting controls

For daylighting to save energy, the electric lighting must be dimmed or turned off in response to natural light. All six of the daylighting systems had problems operating the lights in response to available daylight, from underdimming, overdimming, distracting on/off switching, or sensor installation problems. Each building used different daylighting control strategies:

Cambria

The luminaires in the open office areas are indirect fixtures with 32-W T-8 fluorescent lamps and an installed capacity of 0.75 W/ft^2 (8.1 W/m^2). The LPD of the task lighting in the office areas is approximately 0.5 W/ft^2 (5.4 W/m^2). The luminaires in the second-floor offices have dimmable ballasts controlled by lighting sensors in each office area. Under-cabinet task lighting in each cubicle is controlled by a motion sensor connected to a power strip. CFLs are used in other areas of the building such as the restrooms and lobby. Occupancy sensors are installed on the restroom lighting. Timing

circuits in the breaker boxes control the building ambient and exterior lighting systems with override switches near the main entrance.

BigHorn

Daylighting controls provided by the EMS use three light sensors (exterior, retail, and warehouse). The luminaires in the retail/office area and the warehouse use eight 42-W CFLs. The lamps can be controlled two at a time to provide five lighting level steps for each fixture as an energy-efficient way of matching the available daylighting. Sixteen circuits are available to control the lights: four are used for the exterior lights, four for the warehouse lights, seven for the retail/office lights, and one is reserved for future use. The lighting control circuits in the retail/office area are wired to provide even illuminance levels throughout the store. The lighting controls are configured to turn on some lights in the darker areas first (contractor sales and outside edges of the retail space), then more lights are turned on toward the center of the store as the natural light levels decrease.

CBF

The first-floor office lighting is provided by indirect T-8 lamps with electronic ballasts. The first row of lights on the south side of the building near the windows is dimmable and controlled by photocells. The second-floor office luminaires are 50% direct and 50% indirect. The first two rows of lamps on the south side are controlled by photocells. Task lighting is provided at all workstations. The lights in the normally occupied areas are enabled by the building automation system during occupied hours and have manual/timed override switches. These controls are in parallel, such that if one is on, the lights are on. The timed override switches are push buttons—when the button is pushed, the switch enables the lights for a set time interval.

Oberlin

Corridor lighting is controlled with an occupancy/daylighting hold sensor so the occupancy sensor will not turn on the lights if sufficient daylighting is available. Similar occupancy/daylighting hold sensors combined with manual dimmers control lights in the classroom and offices. As installed, the daylighting hold was not used and postoccupancy rewiring was required to enable the daylighting hold. The atrium and auditorium lights are manually controlled with a continuous dimmer. Restrooms and kitchen lights are controlled with occupancy sensors.

TTF

Daylit zones use ceiling-mounted occupancy sensors connected to the EMS. In addition, a single open-loop analog photocell in the clerestory of the high-bay provides lighting levels to the EMS. The EMS uses the lighting level information to turn the lights on or off. At the time of design, dimming technologies were not available at a reasonable cost. Each zone was calibrated against the single photocell to provide set points for controlling the lights. When light levels drop below the threshold, lights turn on. The lights will turn off only if the minimum light level for each zone has been met for a certain time. This prevents short cycling on variably cloudy days. When motion is sensed, a zone is enabled to come on. After a programmed time delay of no motion, lights are turned off. The lights will come on only if the light level is below the set point and if there is motion. The EMS-based lighting controls provide the ability to change delay times and set points without accessing the sensor directly. It was important that the lighting controls be easily manipulated because of the ceiling heights and accessibility of the sensors. The exception to this control scheme is the hallway located between the offices and the service core. This hallway is served by an integrated motion and daylight sensor that provides security lighting for the building; its lights are not connected to the EMS. When the building is not occupied, no lighting is on. As soon as the front door is moved, the security lighting is triggered on, unless there is ample daylighting. Security lighting is off when daylighting is available.

Zion

The EMS uses stepped controls to manage six zones of T-8 fluorescent strip lighting, which covers most of the open area of the visitor center. The design of the stepped operation called for every other fixture to be on a separate circuit; however, every other row was installed on a separate circuit, which resulted in uneven distribution during stepped control operation. Each zone has a minimum threshold for operation as well as a time delay to prevent excessive cycling. In addition, the EMS controls HID spotlights that highlight the Trombe wall, wall displays, and cooltowers. The offices, back hall, break area, storeroom, and restroom use fluorescent fixtures connected to motion sensor controls. Even though these are on daylighting control, the delay from on to off is long to account for the lamp type. HID is not recommended with daylighting systems because of the long restrike time and the lamp color shifting as the lamps come on.

The Comfort Station uses fluorescent fixtures with T-8 lamps. Compact fluorescent cans are located in the entryway and over the sink area. The sink can be considered a task lighting area and these lights are left on during occupied periods. The entire Comfort Station is split into seven zones of lights controlled with the BAS based on occupancy and available daylighting.

3.2.3 Lighting energy savings

3.2.3.1 Lighting design energy saving

The lighting design energy saving results from the design of the lighting design only with no occupancy or daylighting controls. It compares the maximum LPD allowed by code to the installed LPD. For the case studies, ASHRAE Standard 90.1-2001 was used to determine the maximum allowable LPDs. The lighting design energy saving is not the actual energy saving; it is only a measure of the effectiveness of the lighting design. Some of this saving is from the daylighting design that allows for less electrical lighting to be incorporated into the design. The lighting design savings were the greatest at Zion because of a relatively high LPD code requirement for retail/display lighting of 2.2 W/ft² (23.7 W/m²), as specified by 10 CFR 435. The actual LPD is near 1.0 W/ft² (10.8 W/m²), which significantly reduced installed lighting power.

3.2.3.2 Daylighting and occupancy controls energy savings

The daylighting energy saving represents the actual energy saving and includes the savings that result from the occupancy controls and the daylighting controls while maintaining the minimum illuminance levels as specified by IESNA. It can be calculated by two methods.

- Use the installed LPDs and the operating schedule to compare the measured lighting energy use to the expected use. This approach uses measured data, but the accuracy of the expected energy use is based on an approximation of the annual operating schedule.
- Calculate the energy savings from the calibrated whole-building energy simulations of the As-Built Baseline Model and the As-Built Model. This approach uses the same operating schedules, but the simulation may not exactly represent the as-built daylighting conditions.

3.2.3.3 Total lighting energy saving

For each building we calculated lighting energy savings from daylighting and lighting design. The total lighting energy saving is the sum of the lighting design and daylighting savings (see Figure 3-11 and Table 3-5). For Oberlin, Zion, TTF, and BigHorn, the total lighting saving represented the largest source of the total energy saving. Total lighting energy savings ranged from 93% in the BigHorn warehouse to 30% at CBF.

The total lighting energy saving at Cambria was solely due to the reduced LPD. Minimal daylighting savings were documented, as measurements have shown that the illuminance levels with full daylighting and undimmed electrical lights are at or below the IESNA recommended minimum illuminance level of

30 f.c. (323 lux) for a horizontal work surface in an office (IESNA 2000). The illuminance levels were low because of lower than expected daylight contributions combined with low LPDs, indirect lighting used throughout the building, and high ceilings on the second floor. On the second floor, light from the clerestory windows does not penetrate beyond the first row of cubicles. Too little light enters through the windows and the roof trusses block some of the light. The daylighting along the perimeter walls is not very good because the windows are not high enough, the glass area is too small, the large wood frames limit the glass area and block some of the light, and the first row cubicle walls are too high and block daylight entering these cubicles. In addition, the light shelves on the first floor do not provide enough light to the space. The ceilings are too low, there is not enough glass area, and the reflectance off the light shelves is too low to provide adequate light. Cambria demonstrates how all the necessary daylighting pieces were included in the design, but still failed to deliver significant lighting savings. Daylighting design should be analyzed carefully to ensure a high level of performance. The daylighting design at Cambria incorporated good daylighting design principles and elements (orientation, clerestories, high reflectance ceilings, open office design, and light shelves), but the details were not analyzed to determine likely performance. Small changes, such as more direct lighting (and less indirect lighting with high dark ceilings) and additional fenestration area could have improved the performance.

All six high-performance buildings we studied use daylighting systems to offset electrical lighting energy use. In four cases, daylighting systems were responsible for the largest source of energy savings. The percentage of the total building energy savings that was attributed to daylighting ranged from 32% to 79%, as shown in Table 3-4. Although all these daylighting systems realized various levels of savings, each had problems. Some lacked predicted energy savings, had unacceptable glare, or had lower than anticipated lighting levels. Postoccupancy evaluations addressed some of these problems, which increased energy savings and occupant satisfaction.

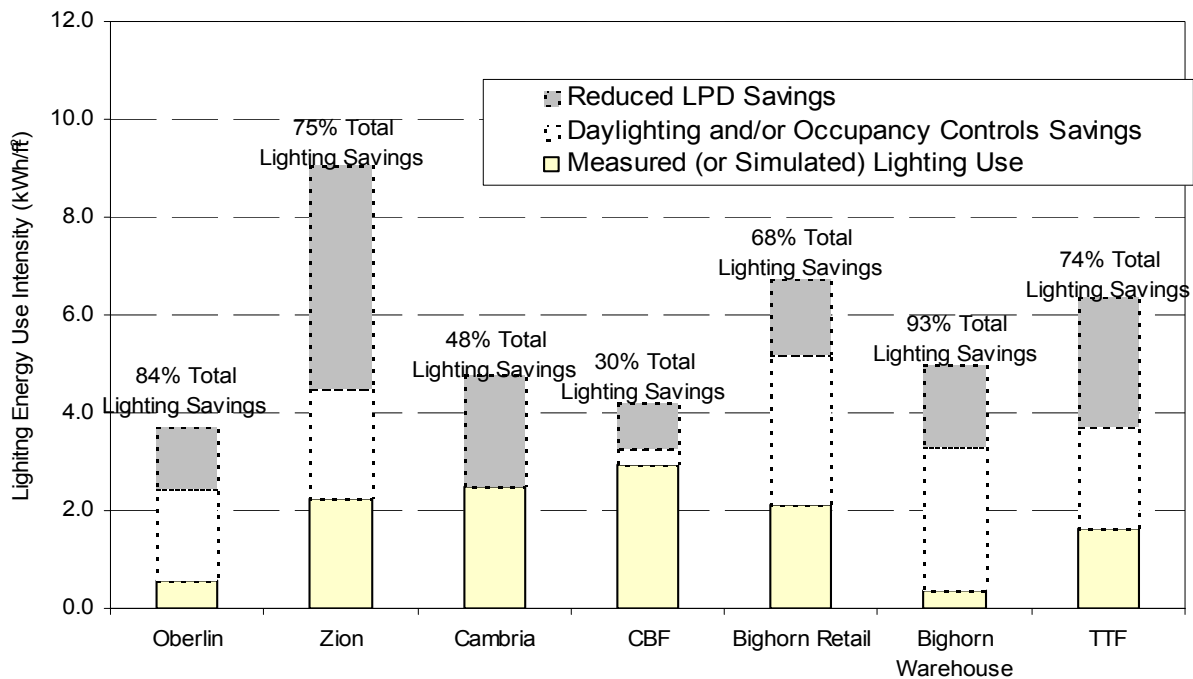

Figure 3-11 Lighting energy savings summary

Table 3-4 Daylighting and Lighting Energy Savings

	Oberlin	Zion	Cambria	CBF	TTF	Bighorn
Baseline total site energy use (kBtu/ft ²) (MJ/m ²)	56.2 (638)	71.1 (807)	61.3 (696)	53.6 (609)	49.1 (558)	60.8 (691)
Total site energy use (kBtu/ft ²) (MJ/m ²)	29.8 (338)	27.0 (307)	36.8 (418)	40.2 (457)	28.5 (324)	39.5 (449)
Lighting energy use (kBtu/ft ²) (MJ/m ²)	2.0 (23)	7.8 (89)	8.5 (97)	9.9 (112)	5.5 (62)	3.8 (43)
Total energy savings (kBtu/ft ²) (MJ/m ²)	26.4 (638.2)	44.1 (638.2)	24.5 (638.2)	13.4 (638.2)	20.6 (638.2)	21.3 (638.2)
Total lighting energy savings (kBtu/ft ²) (MJ/m ²)	10.6 (638.2)	23.2 (638.2)	7.8 (638.2)	4.4 (638.2)	16.2 (638.2)	15.7 (638.2)
Percent of total savings due to lighting savings	40%	53%	32%	33%	79%	74%
Daylighting largest source of total energy savings?	Yes	Yes	No	No	Yes	Yes

Table 3-5 Lighting Energy Savings Summary

Annual Lighting Metrics	Bighorn ¹		Cambria		CBF		Oberlin		TTF		Zion	
	kWh	kWh/ft ²	kWh	kWh/ft ²	kWh	kWh/ft ²	kWh	kWh/ft ²	kWh	kWh/ft ²	kWh	kWh/ft ²
Baseline Lighting Use	R:123,700 W:119,400	R: 6.7 W: 5.2	164,981	4.8	130,563	4.2	50,282	3.7	63,815	6.4	104,981	9.1
Actual LPD Baseline Lighting Use	R: 95,249 W: 78,804	R: 5.2 W: 3.3	85,913	2.5	101,257	3.3	33,100	2.4	37,200	3.7	52,130	4.5
Measured (or Simulated) Lighting Use	R: 39,300 W: 8,400	R: 2.1 W: 0.4	85,913	2.5	90,855	2.9	7,922	0.6	16,287	1.6	26,157	2.3
Total Daylighting and Lighting Design Savings	Retail: 68% Warehouse: 93%		48%		30%		84%		74%		75%	
Actual LPD (W/ft ²)	Retail Warehouse Whole Building	1.3 0.8 1.0	Offices	0.75	1st-Floor Offices 2nd-Floor Offices Conference Room	1.2 1.6 1.4	Offices Classrooms Corridors/Other Whole Building	0.9 1.2 0.5 0.8	Offices and Lab	0.8	Offices Retail/Display Comfort Station	1.0 0.9 1.0
Baseline LPD (W/ft ²)	Retail Warehouse Whole Building	1.6 1.2 1.4	Offices	1.3	1st-Floor Offices 2nd-Floor Offices Conference Room	1.5 1.5 1.5	Offices Classrooms Corridors/Other Whole Building	1.5 1.6 0.7 1.2	Offices and Lab	1.5	Offices Retail/Display Comfort Station	1.4 2.2 1.0

Notes:

1. BigHorn lighting energy use displayed as Retail (R) and Warehouse (W), as these are significantly different space types

3.2.4 *Six elements of successful daylighting systems*

We have defined six elements necessary to achieve energy savings through daylighting. If five of the six elements necessary to good daylighting are done correctly, but one is not, energy savings may not result. A good daylighting design should result from an integrated design process. The daylighting system has to be integrated with the envelope and trade-offs with heating and cooling understood to maximize whole-building energy savings. Even with the good integrated design in each building, the following six elements of a daylighting system are needed to maximize daylighting savings:

1. Design buildings to provide daylighting to all possible zones.

Design daylighting systems into all occupied spaces in a one-story building. In multistory buildings, daylighting should be designed into all occupied spaces on the top floor and all other zones adjacent to an exterior wall. At Oberlin, areas such as the auditorium suffered from lack of daylighting design. At TTF, the nondaylit restrooms and service areas are highly used and could have been easily daylit with tubular daylighting devices and shared daylighting systems (glazing on the interior of the building). At Cambria, some daylighting was designed into all occupied spaces, but minimal savings have been realized because of problems with other daylighting elements. Designing buildings to provide daylighting to all possible zones is the first element to maximizing daylighting savings.

Typically, all zones within 15 ft (4.6 m) of an exterior wall can use perimeter daylighting to reduce lighting loads. Locate minimally used spaces such as storage and mechanical rooms in zones that cannot be daylit. In many cases, restrooms, copier rooms, and hallways are used frequently and typically don't need careful lighting control. These areas are often considered "minimal use spaces." In reality, they are used during most of the building's occupied hours.

Daylighting systems can be designed to meet all the lighting requirements in the daylit zones for most of the daytime hours. The best way to realize lighting energy savings is to turn the lights off. It is better to overdesign daylighting systems so daylight can offset the entire lighting load for most of the daytime occupied hours. Generally, the daylighting should be designed to provide twice as much illuminance as the electrical lighting system. Sufficient daylighting can be achieved with relatively small aperture areas. Oversized apertures are counterproductive, especially in zones where cooling loads dominate. Daylight modeling and whole-building energy simulation tools are recommended for proper design of daylighting systems.

Systems that require the full daylighting contribution and the electrical lights to operate and provide sufficient illuminance will be more likely to have inadequate lighting levels. For example, classrooms at Oberlin could be completely daylit (without electrical lighting) for 52% to 73% of the daytime hours, depending on the time of year. In contrast, full electrical lighting combined with the full daylighting contribution at Cambria was required to provide sufficient illuminance levels in the offices.

2. Provide for glare mitigation techniques in the initial design.

All the case studies documented glare problems. Attempts to address these problems in response to occupant complaints often resulted in reduced daylighting contributions. Blinds are often manually adjusted in response to unwanted glare. Typically the blinds on the clerestories high above the occupants were completely closed. The problem occurred when they were not readjusted, as they were hard to access. This completely disabled the clerestory daylighting. Techniques that do not require occupant interaction for glare mitigation, such as diffusing glass, light-deflecting panels, full shading overhangs, and light shelves should be considered for all south-facing clerestories. Other daylighting techniques that do not have a direct-beam component, such as north-facing clerestories and tubular daylighting devices, should also be considered in the daylighting design.

The first glare example at Zion (Figure 3-12) shows excessive glare on the bookstore checkout counter and staff. This occurred during an early morning in December from direct solar gain through the clerestories. Glare can overwhelm staff and customers because the checkout stands, whose location was determined shortly before the building was occupied, are poorly placed relative to direct solar gain. In the rest of the areas, direct solar gain and glare do not cause problems because occupants are not focused on a single area and can move around to avoid glare. When the checkout counter glare was identified as a problem, diffusing film was placed on the clerestory glass to control direct solar gain.



Figure 3-12 Zion bookstore checkout counter glare from clerestories

The second glare example at Zion (Figure 3-13) shows excessive direct solar gain in the southeast office on a December afternoon. This glare is the result of direct gain through the unshaded southern windows above the Trombe wall. The occupants typically use a temporary shading device (cardboard) when glare is a problem. Adjustable blinds or diffusing film would provide a permanent solution.

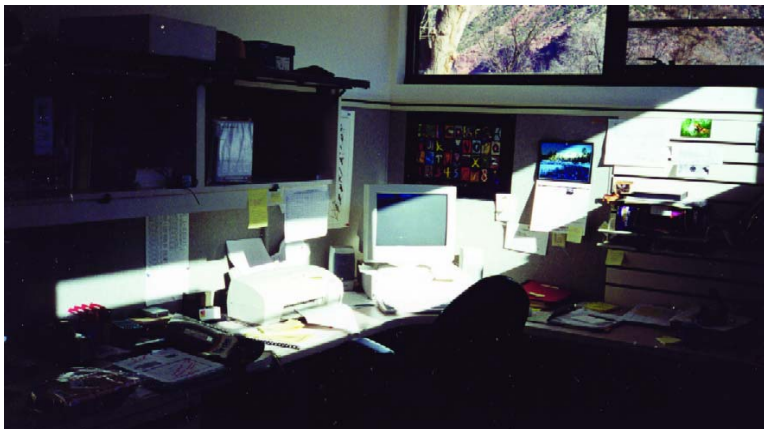

Figure 3-13 Zion office afternoon glare

Daylighting at CBF penetrates across the second floor, but glare problems are evident, as shown by illuminance readings higher than 186 f.c. (2,000 lux) and observations of occupants setting up makeshift shading devices (see Figure 3-14). The CBF glare problem suggests that a more robust solution for reducing glare should be explored. The broad expanse of windows along the south

facade has more area than is needed for daylighting alone. (This wall probably also creates additional cooling and heating loads.) There are several solutions to this problem. Placing diffusing films on the glass is the easiest solution; however, this would reduce the view of the bay. The diffusing films and light-deflecting devices would help light the ceiling. Hanging translucent shades would minimize the glare. Flat screen computer monitors would reduce glare and plug loads.



Figure 3-14 CBF glare mitigation solution

At Cambria, the south-facing clerestory windows can cause undesirable lighting conditions. At low sun angles, they can admit direct beam radiation, and they can be very bright at other times, causing contrast and glare problems. Automatic sunshades, which are controlled by an exterior photosensor, are specified on the interior of the windows to block the direct beam radiation. The sunshades block too much light and defeat the purpose of the clerestory windows. Other options for these windows are to diffuse the incoming light with frosted or patterned glass or a light-diffusing film on the glass, or direct the beam radiation to the ceiling with a louver system.

The manually operated brushed-aluminum blinds on the TTF clerestory windows are further examples of misapplied glare mitigation techniques that reduce daylighting. The original plan for operating these blinds was to manually adjust the mid-bay blinds according to seasonal solar angles. In theory, this operation would deflect direct solar gains up to the ceiling during the winter and allow diffuse daylighting in the summer. In reality, the blinds have been difficult to operate as they are 12 ft (3.7 m) above the floor. The blinds remain closed and not adjusted, which defeats the mid-bay daylighting. In response, we installed diffusing films and light-deflecting panels so the daylighting success does not depend on occupant interaction.

If glare mitigation techniques are not addressed in the initial design, typical solutions such as blinds defeat the daylighting systems and there will be no benefit. Diffusing films and light-deflecting panels have successfully eliminated most of the glare on work surfaces without defeating daylighting. Some types of deflecting panels will actually increase daylighting performance by reflecting more light deeper into the lighting zone. The drawback of these solutions is the view of the sky can be lost.

3. Provide automatic, continuously dimming daylighting controls for all daylit zones.

Automatic, continuously dimming daylighting controls should be used to maximize savings for all daylit zones that have daylighting contributions. Occupants cannot be relied on to dim the lights in response to available daylight. The lighting controls in the open second-floor office at CBF are manual on/off (except for the first two rows, which are dimmable and connected to photocells). More of the lighting on the second floor could be controlled to harvest daylight. Daylighting provides considerable underused natural light to the second-floor offices, the conference pavilion, and the lobby. The operator currently switches banks of lights off (sometimes by removing lamps), but automatic controls would represent a better long-term solution. At Oberlin, appropriate manual control of the electrical lighting is necessary to realize daylighting savings in the classroom, corridor, atrium, and offices. The controls, as installed, would turn the lights on to 50% when the zones were occupied. The daylighting controls were then dependent on the occupants to dim the lights in response to daylighting. In the classrooms and corridors, the occupancy sensors were rewired for a daylighting hold so that the electric lights did not automatically turn on if there was enough daylighting. The manual dimming controls in the atrium and auditorium were generally managed appropriately, although periods of mismanagement were identified. For typical occupants who are less aware of their building operations, this type of daylighting control would not result in significant daylighting savings. Continuously automatic dimming daylighting controls, combined with occupancy sensors, would be the optimal control solution.

Automatic controls that dim and energize lighting circuits according to available daylight are typically better than stepped controls. Dimmers that are fairly linear in the relationship of light output to energy use should be specified. The occupants tend to be distracted when the electric lights switch on and off in a stepped fashion. Stepped daylighting controls have had varying degrees of success at TTF, BigHorn, and Zion, but continuously dimming T-8 fluorescent systems would be better in each case. For intermittently occupied daylit zones such as corridors and restrooms, occupant sensors combined with a daylighting sensor have successfully reduced lighting energy use. In these areas stepped controls are typically acceptable.

When a manual override for automatic daylighting controls is needed, a maximum illuminance set point should be included in the manual control strategy. This will ensure that even when the lights are manually controlled to be on, daylighting can still offset lighting energy use. Occupancy sensors should be used to disable the manual override when the zone is unoccupied.

Central lighting controls tended to work better than distributed controls, and overly complex systems were problematic. The complex systems with sensors in each zone were difficult to calibrate, as oscillations frequently occurred when the sensors detected light from a neighboring zone. A simpler solution that used a single sensor to measure daylight availability was often easier to calibrate. This worked when the primary source of daylight was from the south-facing fenestration, and data from a single sensor could be used to provide separate control for each individual zone. The lighting level set points with respect to this sensor are unique for each lighting zone and set to provide necessary light levels.

4. Design interiors to maximize daylighting contribution.

Daylighting and indirect lighting fixtures benefit from lightly colored interior surfaces that reflect light. Dark colors are counter to design for daylighting. Dark ceilings and structural elements were common reasons for reduced savings and poor daylighting distribution. Figure 3-15 shows the relatively dark colors in CBF's interior because of unfinished wood products, the rough surface of OSB and laminated beams, and exposed ductwork. Finishing the interior, especially the ceiling, would provide surfaces with higher reflectivity and brighten the space, which would allow for increased use of daylighting and less waste from the indirect fluorescents.

Measurements indicate that daylight is sufficient because of the large amount of glazed area. The dark colors absorb much of the light and provide contrast to the bright outdoors. This results in a visually difficult environment. The distribution of natural daylight and indirect electric lighting would be improved with lighter colored interior finishes.

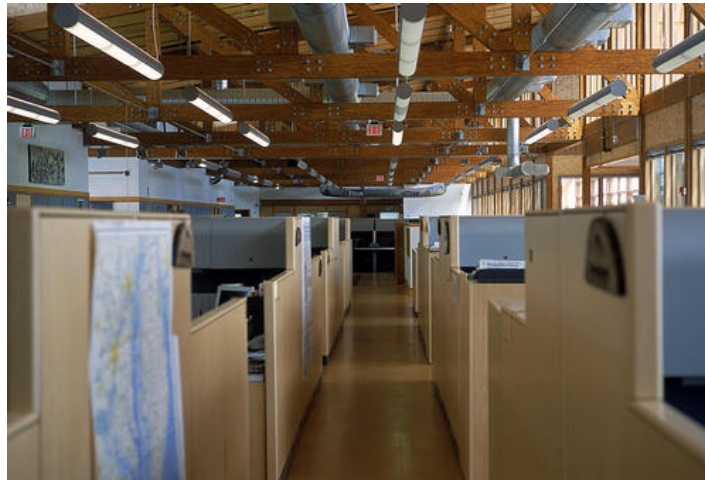

Figure 3-15 CBF second-floor ceiling, beams, and ducts

The exposed beams in the ceiling structure often blocked daylighting from entering into the space. Dark structural elements reduced daylighting savings and distribution at Zion, Oberlin, CBF, Cambria, and TTF. The distribution of natural daylight and indirect electric lighting would be improved with lighter colored interior finishes that have a reflectance greater than 90% and can effectively diffuse direct beam daylighting. Highly specular interior surfaces should only be used to reflect direct beam up to the ceiling (such as a light shelf), where glare is not an issue. At Zion, the dark structural beams throughout the buildings were not considered when the daylighting features were designed. These beams absorb and block significant portions of the clerestory daylighting and uplighting (see Figure 3-16).



Figure 3-16 Zion's 88% uplighting with T-8 fixtures (note the dark ceilings and beams combined with minimal down lighting)

At TTF, ceilings, walls, furniture, and floors should be bright white to help reflect daylighting. If possible, smooth surfaces should be used to prevent shadowing on the ceilings, making the ceilings appear brighter. A high-reflective (greater than 80%) white finish was added on interior surfaces to support the daylighting features; however, cubicle walls, furniture, and carpeting placed in the open office area have a reflectance of less than 50%.

Interior daylighting design should include high reflectivity nonspecular (diffuse) finishes to spaces that are daylit or have indirect light fixtures. In addition:

- Cubicle partitions were not designed to maximize daylighting at the work surface. Lighter partition walls and cubicles that are oriented to optimize daylighting can result in increased daylighting savings. Cubicle walls, furniture, and carpeting should all have light, highly reflective colors.
- Anticipate and design for unavoidable elements that will reduce daylighting aperture and transmittance, such as light absorbing merchandise and shelving in retail spaces, cubicle walls, window openers, frames, mullions, and screening.
- Specify actual visible daylighting areas, not just fenestration areas. Frames, screens, window openers, and mullions can all reduce the visible fenestration area.

5. Integrate the electrical lights with the daylighting system.

The rows of electrical lighting circuits should run parallel to the daylighting source. Each circuit should be controlled separately so that they can be dimmed as necessary in response to the daylight levels that vary with distance from the source.

Uplighting in daylit spaces with high ceilings should be used sparingly and not at all with high dark ceilings. Integrating uplighting into daylit systems with high ceilings has been difficult, as effectiveness and illuminance levels have suffered. If combined with downlighting, controls should be provided so that the uplighting can be separately controlled. Indirect lighting works best close to highly reflective ceilings.

Lower LPDs are possible in daylit buildings, if task lighting is provided at the critical work surfaces. The daylighting system should be designed to exceed the recommended light levels, such that it is not noticed when the electric lighting is off. The electric lighting design should use LPDs for night use and should account for the contrast between dark exterior lighting and the interior environment. Task lighting should be used for critical lighting needs. Appropriate placement and use of occupant-controlled task lighting is essential for daylit buildings with reduced LPDs, especially for detailed task work.

6. Commission and verify postoccupancy energy savings.

Commissioning a daylighting system that consists of adjusting photosensors and ensuring proper sensor placement is required so the electric lighting system responds properly to daylight. Verifying lighting energy savings according to NREL's lighting measurement procedure (Deru et al. 2005) is a good method to determine whether all six elements have been successfully implemented. Postoccupancy daylighting evaluations in all six case studies resulted in changes to the daylighting systems, which addressed occupant complaints and increased daylighting savings. Each building had glare problems. Clerestory glare problems were addressed with diffusing films, and adjustable blinds recommended for occasional use. We added more task lighting in critical areas, as the stepped controls, uplighting, and daylighting did not provide adequate illuminance levels for detailed work.

Table 3-6 summarizes the success of these daylighting elements for each building. Daylighting elements that were partially successful are noted with a gray circle. For example, Oberlin was partially successful

in including daylighting in all possible zones, as the building was completely daylit except for the auditorium.

Table 3-6 Six Elements Required to Maximize Daylighting Savings

	Oberlin	Zion	Cambria	CBF	TTF	Bighorn
1. Daylighting to all possible zones?	<input type="radio"/>	<input checked="" type="radio"/>	<input type="radio"/>	<input checked="" type="radio"/>	<input type="radio"/>	<input checked="" type="radio"/>
2. Glare mitigation in initial design?	<input type="radio"/>	<input type="radio"/>	<input type="radio"/>	<input type="radio"/>	<input type="radio"/>	<input type="radio"/>
3. Automatic daylighting controls?	<input type="radio"/>	<input checked="" type="radio"/>	<input type="radio"/>	<input type="radio"/>	<input checked="" type="radio"/>	<input type="radio"/>
4. Interiors designed to maximize daylighting contribution?	<input type="radio"/>	<input type="radio"/>	<input type="radio"/>	<input type="radio"/>	<input type="radio"/>	<input type="radio"/>
5. Lighting systems integrated with daylighting system?	<input checked="" type="radio"/>	<input type="radio"/>	<input type="radio"/>	<input type="radio"/>	<input checked="" type="radio"/>	<input checked="" type="radio"/>
6. Postoccupancy energy savings commissioned and verified?	<input checked="" type="radio"/>	<input checked="" type="radio"/>	<input checked="" type="radio"/>	<input checked="" type="radio"/>	<input checked="" type="radio"/>	<input checked="" type="radio"/>

- Yes
- Limited to partial application or success
- No

3.3 Integrating the Envelope and Mechanical Systems

Heating is responsible for 25% of the total energy consumption in office buildings, cooling uses 9%, and ventilation uses 5% (Figure 3-17) (EIA 2005a). Combined HVAC loads are responsible for 39% of the total energy consumption in office buildings. Thus, lessons learned about applying efficient HVAC design and controls to minimize energy use are valuable to the industry and to future ZEB designs.

An integrated approach to building design is the best way to lower energy use and cost. The building must be engineered as a system if the technologies are to be integrated. Each building first reduced HVAC loads with increased insulation and tightened envelopes, engineered windows and overhangs, reduced internal gains with daylighting, and an east-west axis with an optimal orientation. Envelope-integrated HVAC technologies, including Trombe walls, natural ventilation, passive solar gains, and cooltowers, met some of the remaining HVAC loads. Additional energy-efficient HVAC technologies, including ground-source heat pumps, evaporative cooling, and energy recovery ventilators (ERVs) were then used to meet any remaining HVAC loads.

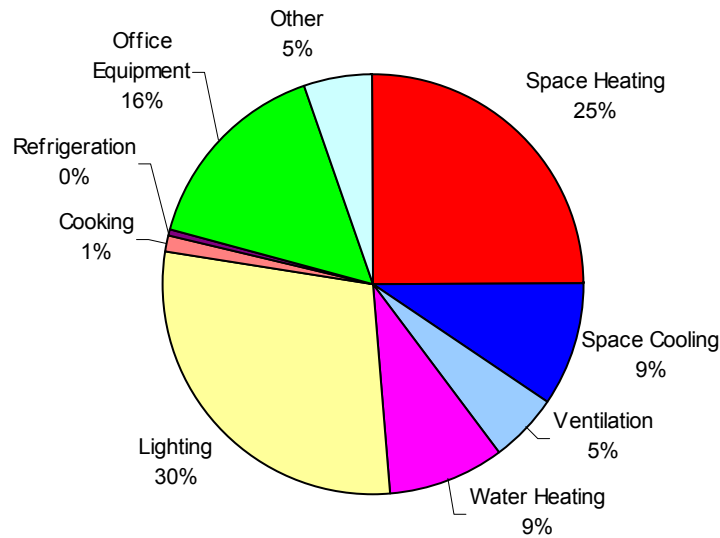

Figure 3-17 Typical site end uses for office buildings (percent of total) (EIA 2005a)

3.3.1 HVAC system descriptions

The case study buildings use a variety of different HVAC systems. Ground-source heat pumps with ERVs are the primary heating and cooling sources for Oberlin, CBF, and Cambria. Water-source heat pumps exchange energy with the ground to provide heating and cooling at higher efficiencies than traditional air-source heat pumps. Various forms of natural ventilation were designed into the buildings and HVAC systems at Oberlin, BigHorn, CBF, and Zion. Direct and indirect evaporative cooling systems meet all the cooling needs for TTF and Zion. Oberlin and BigHorn use radiant heating in-floor slabs and unit heaters. Each of these systems, except for Cambria, is controlled with an EMS. Table 3-7 summarizes the HVAC and control systems for each building.

Table 3-7 HVAC Systems in High-Performance Buildings

Building	Heating Systems	Cooling Systems	Ventilation Systems	Controls
Oberlin	Ground-source heat pump loop with central variable speed drive (VSD) ground loop circulation pump		100% outdoor air with ERVs	EMS under facilities control via a contractor
	Hydronic radiant units Limited passive solar gains	Limited natural ventilation	Limited natural ventilation	
Zion	Trombe walls Electric radiant ceiling panels Passive solar gains	Natural ventilation Direct evaporative cooltowers	Natural ventilation	EMS under researcher control
Cambria	Ground-source heat pump loop with distributed ground loop circulation pumps for each heat pump		ERVs	Independently controlled by zone thermostats under occupant control
CBF	Ground-source heat pump loop with central VSD ground loop circulation pump		Natural ventilation	EMS under local manager control (owner)
	Propane boiler for hydronic fin and tube radiators	Natural ventilation	ERVs	
TTF	Campus hot water coils in variable air volume boxes Passive solar gains	Direct/indirect evaporative cooling Dry-bulb economizer	Mixed return and outdoor air	EMS under campus facilities control (owner)
BigHorn	Gas-fired boilers for hydronic in-floor slab radiant heat	Natural ventilation	Natural ventilation	EMS under owner control

3.3.2 Using the architectural design and envelope to create low-energy buildings

The architectural design and envelope have major impacts on building energy, lighting, and comfort performance. Envelope features include form, shading, daylighting, choice of materials, sizing, orientation, and glass specification. Too often, an inefficient envelope design must be compensated for with more energy-intensive (and costly) mechanical and lighting systems. Therefore, the envelope design should be the first step in creating low-energy buildings. The mechanical and lighting systems can then provide the remaining (smaller) thermal and lighting comfort needs. Low-energy architecture is not effective if mechanical and lighting systems have to solve problems created by inadequate envelopes.

Each building reduced HVAC energy use through increased insulation levels and tightened envelopes, engineered windows and overhangs, reduced internal gains with daylighting, and an east-west axis with an optimal orientation. Envelope-integrated HVAC technologies, including Trombe walls, natural ventilation, passive solar gains, and cooltowers, met some of the remaining loads.

By using the mechanical system to make up for what cannot be accomplished by architectural features and envelope alone, the mechanical system does not have to correct for an architectural design that is climatically ill conceived. The Zion Visitor Center is a good example of this concept: daylighting was designed into the roof structure through clerestories, the cooling system was integrated into the vertical tower elements, Trombe walls were designed into the south-facing walls, and natural ventilation is provided through operable windows. At BigHorn, a conventional cooling system was not needed because the building had increased envelope insulation and reduced internal gains. All cooling could then be provided through natural ventilation.

3.3.2.1 Watch out for overglazing

Glass has a very strong impact on energy, comfort, and lighting performance, which can be positive or negative depending on many factors. Simulations allow us to optimize glass optical and thermal properties, sizing, orientation, placement, and shading. Additional glass is often added to achieve transparency—a common architectural desire. However, the strong exterior contrast from the sun combined with reflections often prevents the desired transparency, even with lots of glass. Transparency creep is evident at Zion, Oberlin, and CBF. Zion is overglazed on the north façade, Oberlin on the east side, and CBF on the south side. Additional shading would help to reduce cooling requirements caused by excessive glazing at both CBF and Oberlin. The structure outside the south-facing glass at CBF might be refitted with additional shading. A vine trellis on the east side of Oberlin’s atrium was designed to provide summer shading, but was never installed. Before adding shading, a detailed analysis should be conducted that takes into account increased heating loads, reduced PV output, decreased daylighting, and glare problems.

3.3.2.2 Minimize thermal bridging

HVAC loads are affected by the overall thermal performance of the building envelope. Although high levels of thermal insulation are important, two- and three-dimensional heat flows through construction details can also have an important impact; these heat flows are referred to as thermal bridges.

Although designers took care to develop designs that would minimize thermal bridging, four problem areas at the TTF were identified that add to its thermal loads.

- The window frames form a thermal bridge. Figure 3-18 shows a sample of infrared images used to determine that the window and door frames installed were not thermally broken as specified. Compared to the baseline TTF model, as much as 13.6 MMBtu/yr (3,986 kWh/yr) are lost through the window frames because they are not thermally broken.

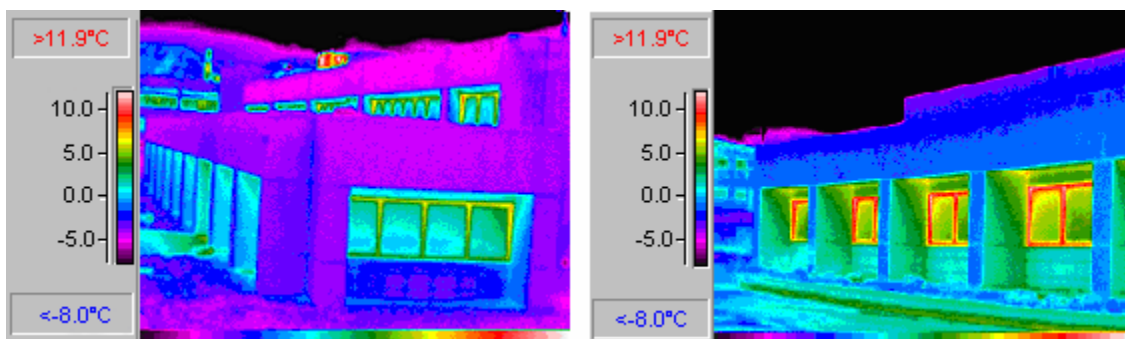

Figure 3-18 TTF infrared thermal images showing heat loss through window frames

- There is a thermal bridge where a retaining wall meets the building. Although the impact of this thermal bridge on the annual heating and cooling performance is minimal, multiple incidences of thermal bridging can offset savings from the low-energy envelope. This flaw was built according to plan and should have been identified during the design phase.
- During construction, the foundation insulation was relocated for structural reasons. As a result, 6 in. (15 cm) of insulation was removed, which created a thermal bridge that is approximately 390 ft (119 m) long by 6 in. (15 cm) wide. NREL estimates that an additional 4.3 MMBtu/yr (1,260 kWh/yr) are lost through this thermal bridge. Figure 3-19 shows infrared thermal images that indicate heat loss through the foundation.

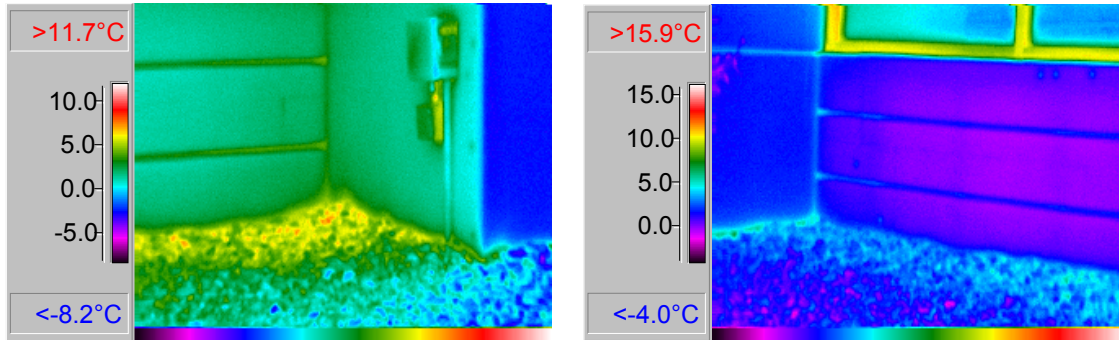

Figure 3-19 TTF infrared thermal images showing heat loss at the foundation

- The high-bay garage door is a significant thermal bridge. Figure 3-20 shows the temperature distribution of the high-bay roll-up door during a summer morning. Incident morning sun heats this door, which causes summer comfort problems in this section of the high-bay. The interior surface of the east garage door in the high-bay of the TTF can exceed 110°F (38°C) during morning summer hours. As shown in Figure 3-20, the floor-to-ceiling temperature distribution can exceed 30°F (16.7°C) in the high-bay, which results in localized discomfort and additional cooling loads. A high-reflectivity and high-emissivity exterior paint, combined with a low-emissivity interior paint, would reduce the heat absorbed by the door and reduce heat emitted to the space. Reducing heat emitted from this door would improve thermal comfort at the east end of the high-bay. Other solutions include external shading. Although more expensive, replacing the door with a well-sealed R-25 ($R_{SI}=4.4$) panel garage door would be the optimal solution, and would align with the design intent for the rest of the TTF envelope.

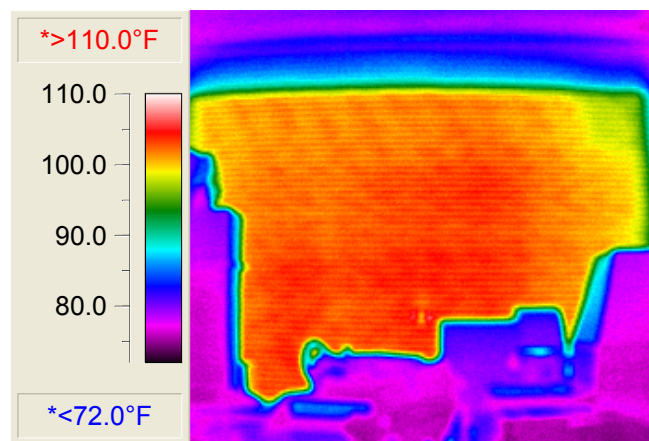

Figure 3-20 TTF high-bay insulated roll-up door thermal bridging

Another example of a significant thermal bridge is in a small, unconditioned storeroom at Zion. This storeroom often overheats because its dark brown metal double doors collect heat during the morning. The internal temperature of the doors radiates to employees in the storeroom (see Figure 3-21). The doors could not be painted white because the exterior color of the building had to follow NPS standards, which is dark brown. To help cool and ventilate this zone, several small fans were installed along the floor vents. Designing the steel door with increased insulation and a radiant barrier would have been a better solution, in line with the design intent used for the rest of the building. A uniform thermal envelope that includes well-insulated storeroom and garage doors can eliminate comfort problems and unnecessary heating and cooling loads.

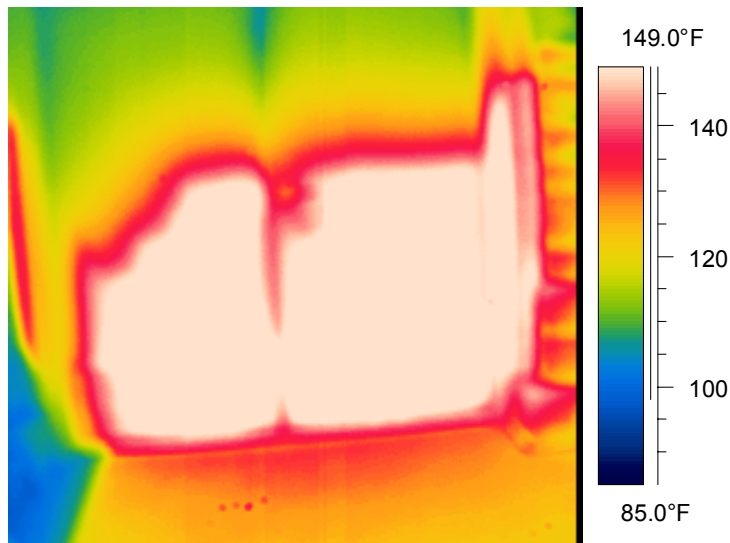

Figure 3-21 Zion infrared image showing interior surface of storeroom door overheating from solar radiation

Ground heat transfer is another area with complex three-dimensional heat flows. Many questions surround modeling heat transfer through slab-on-grade floors. The common practice of insulating only the perimeter of the slab is justified only if the ground under the center portion of the slab will eventually reach an equilibrium temperature under the influence of the controlled environment above the slab. Through STEM tests (Subbarao et al. 1989) and thermography, NREL found that more heat is lost through the floor and window frames than models predicted. Based on other work (Deru and Kirkpatrick 2001), researchers suspect that the ground under the center of the slab is not reaching equilibrium. Additional work would be required to determine the benefits and costs of insulating the entire slab. One impact of slab heat transfer losses is comfort. Based on thermal comfort models, a cold floor adversely affects foot temperature which is a critical component for occupant comfort. Insulating floors will result in warmer floors and may result in lower overall building temperatures because people with warmer feet can be more comfortable at lower zone temperatures.

Designing the envelope to minimize thermal bridging is good practice. An otherwise well-insulated envelope can suffer if a single component lacks appropriate thermal properties. Additional consideration is typically needed to ensure that doors are well insulated (especially those that have significant direct gains), window frames are installed with thermal breaks, and the insulation at the interface with ground-coupled surfaces has been appropriately specified. Ensuring insulation details are included in the specifications and then implemented during construction is essential to achieving a thermally uniform envelope.

3.3.3 *Passive solar heating*

Traditionally, passive solar heating is not beneficial for commercial buildings because they have abundant internal heat gains from large numbers of people, lights, and equipment, and, except for morning warmup, require cooling much of the year. However, this convention breaks down for daylit buildings in which the electric lights no longer provide significant heat gains because they are often turned off during the day. Zion, BigHorn, Oberlin, TTF, and Cambria are heating-dominated buildings. Passive solar heating through indirect gain Trombe walls provide a significant portion of the heating at Zion, and passive solar direct gains contribute to the heating at TTF.

Many passive solar features were integrated into the TTF final design. The design team took advantage of Colorado's sunny climate by carefully selecting, orienting, and placing windows and clerestories. The passive solar and daylighting design of the building incorporates 88% (1,134-ft² [105.4-m²]) of its total window area as a single row of view glass (492 ft² [45.7 m²]) and two rows of clerestories (642 ft² [59.6 m²]) along the southern facade. An additional 8% of the total view glass area is on the east (56 ft² [5.2 m²]) and west (56 ft² [5.2 m²]) facades; the remaining 1% is positioned on the north wall (38 ft² [3.5 m²]).

NREL engineered the building to provide passive solar gain during the winter months and minimize this gain during the summer months. The selected glass type allows solar energy to enter the building for passive heating energy. South-facing clerestory windows have a high solar heat gain coefficient (SHGC) of 0.68 (shading coefficient of 0.76); all others have a lower SHGC of 0.45 (shading coefficient of 0.51). The ground-level windows were designed for viewing and are larger than needed from an energy perspective. To avoid overheating and glare from direct gain through these windows during the winter, the view windows have a lower shading coefficient than the clerestory windows. All windows were engineered with a low-e coating to increase thermal resistance. Engineered overhangs were designed to block direct solar radiation during the warm summer months when sun angles are high. Although not a prominent design feature, thermal mass in the floor and north wall helps to minimize temperature swings. Opaque envelope components for the TTF were selected to be highly insulating and to expose thermal mass to the interior.

Direct gains are used at the TTF to provide a portion of the heating needs. The building typically requires heating only during the early morning hours to warm up from nightly temperature setback. Although the temperature set point is set back to 64°F (19°C) every night, the temperature in the TTF rarely drifts that low. Heating loads on a cloudy day and a sunny winter day were examined to understand the direct solar gain benefit (see Figure 3-22). For both days, the set point was 64°F (19°C) from 5:00 p.m. to 12:00 a.m.; the remainder of the day was set to 70°F (21°C). After the morning warmup, passive solar heating and internal gains met most of the building's heating requirements.

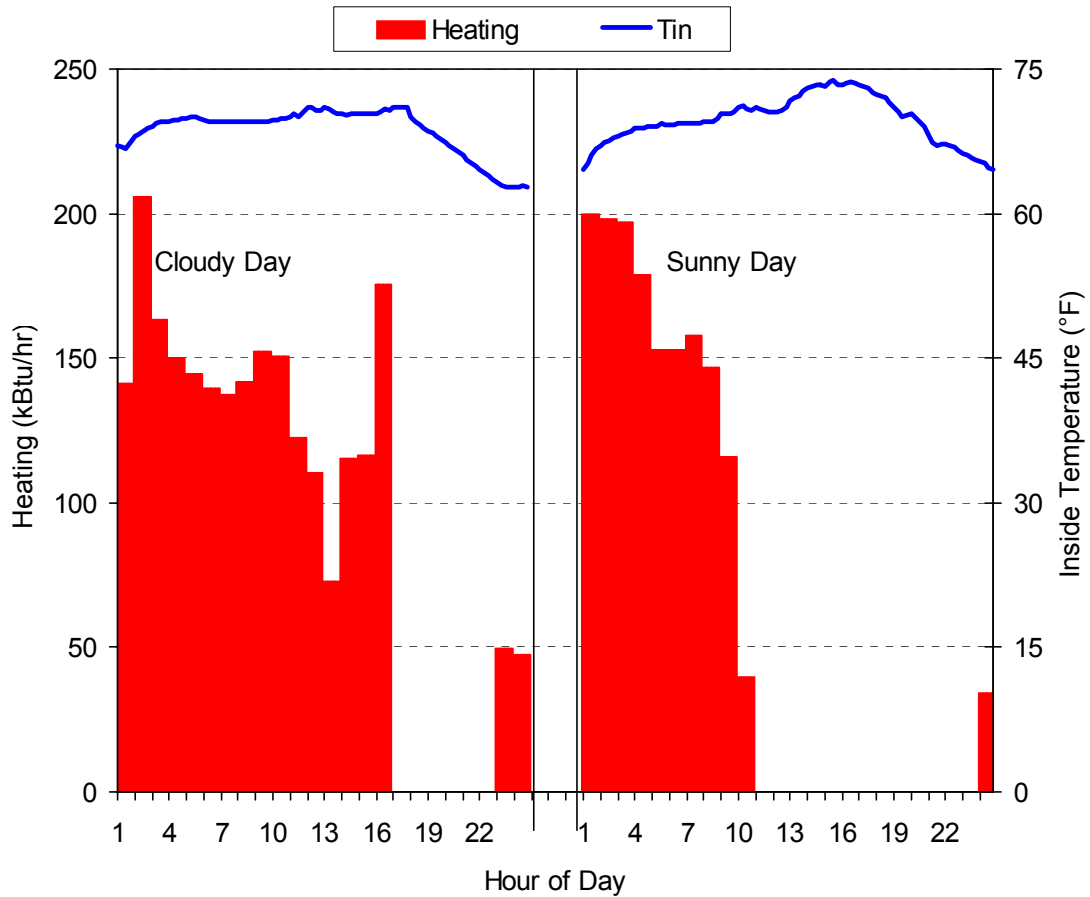

Figure 3-22 TTF heating loads on a cloudy day compared with heating loads on a sunny day

3.3.3.1 Passive solar heating with Trombe walls

The only building in the case studies to use a Trombe wall was the Zion Visitor Center. The Trombe wall was integrated into the envelope to provide a passive radiant heating source. Design details for this Trombe wall are shown in Figure 3-23. The 6-ft (1.8-m) high Trombe wall (740-ft² [68.7-m²] total area) is located on the entire length of south-facing walls. The wall makes up 44% of the south-facing wall area. The Trombe wall is constructed of 8-in (20-cm) grout-filled concrete masonry units (CMUs) with an R-value of 2.5 hr·ft²·°F/Btu (0.4 K·m²/W). The other walls are 6-in (15-cm) framed walls with an R-value of R-16 hr·ft²·°F/Btu (2.8 K·m²/W). The Trombe wall has a single layer of high transmittance patterned glass installed on a thermally broken storefront system.

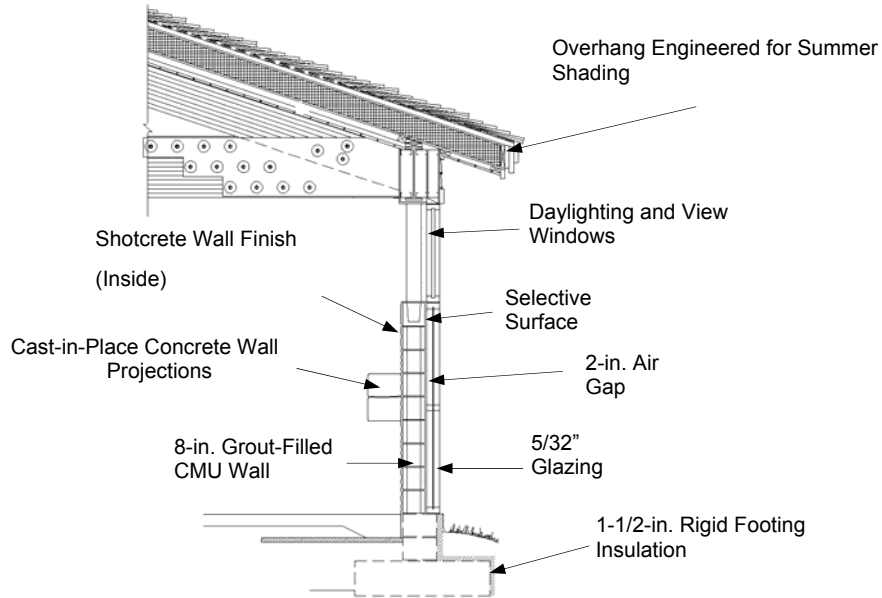

Figure 3-23 Cross-section details of Zion Trombe wall

3.3.3.2 Thermal and construction details of Trombe walls are important

A major benefit of the Trombe wall is its ability to provide a uniform radiant heating source. This improves thermal comfort during the heating season. Also, as the heat transfer is governed by the thermal difference and the thermal resistance, the thermal resistance on the interior of the wall must be minimized. The interior of the Zion Trombe wall includes in the design cast-in place concrete projections. These projections could be used as shelves to display product. The hope was to minimize the occupant's desire to place bookcases or other obstructions in front of the wall. This has worked fairly well; however, the occupants have had a strong urge to place objects in front of the wall.

To reduce the thermal resistance, we verified construction of the CMU wall to ensure the concrete block cores were completely filled. This appears to have been effective. A problem area has been the shotcrete used as a finish material on the inside of the wall. Although a massive building material, there were air gaps between the material and the CMUs on the wall. These problems were detected using thermography as cooler temperatures on the wall surface. Placement of the footing insulation was also verified during the construction process to ensure proper installation. The location of this insulation is critical, as three-dimensional heat transfer to the ground can diminish Trombe wall performance. By thermally decoupling the footings from the ground with insulation, unnecessary heat loss is avoided and more heat from the Trombe wall is supplied to the building. This was effective as shown by minimal stratification of temperatures through the Trombe wall.

3.3.3.3 Trombe walls can meet a significant portion of the heat load

The Zion Trombe wall daily performance during the 2001–2002 heating season is shown in Figure 3-24. The electric radiant heating system used 22,680 kWh during the course of one year and the Trombe wall contributed 20% of the total heating to the building. The Trombe wall imposed a heating load on the building for only two of the 151 days of the 2001–2002 heating season. For the other 149 heating days, the wall was net positive. The peak heat flux through the wall was 11.2 W/ft² (89 W/m²), or 8.3 kW over the entire Trombe wall area. The average efficiency of the wall over the 2001–2002 heating season (defined as the heat delivered to the building from the Trombe wall divided by the total solar radiation incident on the exterior of the wall) was 13%.

During the first three months of the 2002–2003 heating season, the total electrical heating energy used was 5,389 kWh, while the Trombe wall provided approximately 41% of the energy or 3,800 kWh. This percentage was greater than the 2001–2002 heating season of only 20% because of improved controls of the electrical heating system and differences in weather.

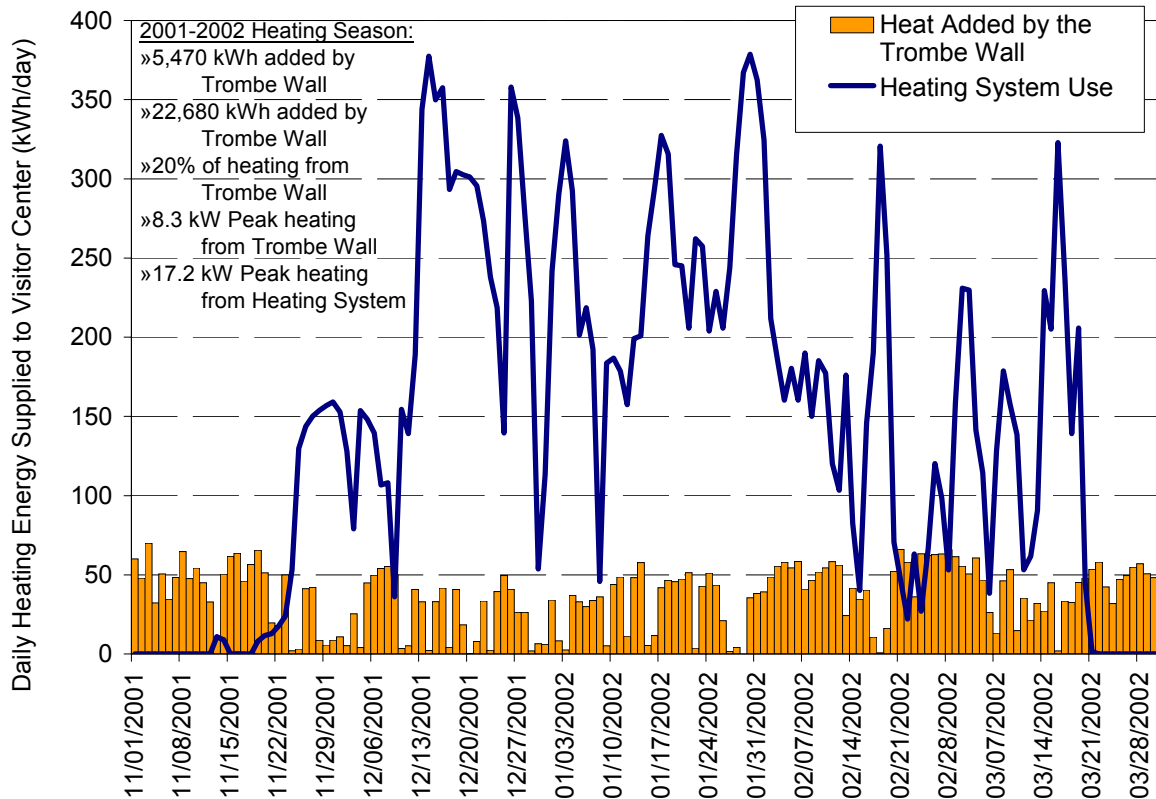

Figure 3-24 Zion Visitor Center Trombe wall and heating system performance, 2001–2002 heating season

3.3.3.4 Consider net annual performance when designing Trombe walls

A potential design issue to consider with the Trombe wall is overheating in the summer and swing seasons. The overhangs are designed to shade the Trombe walls during the cooling season. Even though the Trombe walls are shaded in the summer, the walls impose an additional cooling load on the buildings. This is because early morning and late afternoon radiation is not shaded and diffuse and reflected radiation is not negligible. Additionally, the insulation values of these walls are low. For Zion, the additional cooling loads do not impact performance, as the passive direct evaporative cooling system provides an abundance of cooling. The annual net effect of the wall has to be considered in its design, as the additional cooling loads can affect the cooling system performance. For buildings with conventional air-conditioning systems, careful Trombe wall design is essential so summer gains are minimized. If buildings are flushed with evaporative cooling, the summertime cooling loads generated by the Trombe walls do not pose a problem.

3.3.4 Natural ventilation

Four of the buildings used natural ventilation for cooling and providing outdoor air requirements when outdoor conditions are favorable. Table 3-8 provides control schemes and cooling types for each case study. Zion was designed to be entirely naturally ventilated with a stack effect that is primarily driven by

cool air provided by the cooltowers. The EMS mechanically operates windows in the clerestory. Natural downdraft cooltowers that require no fans are also considered natural ventilation; pumps are controlled by the EMS. Lower manually operated windows complete the scheme.

CBF uses a similar strategy with manually operated lower windows and high windows operated by the EMS. Signs, lit by the EMS, help direct staff to open the lower windows (as shown in Figure 3-26). In practice, the so-called natural ventilation at CBF is often operated as a hybrid system with the aid of exhaust fans.

BigHorn has motor-actuated clerestory windows that are controlled either by the EMS or by wall switches. The front doors, which open during normal business hours in the summer, provide supply air to complete the scheme. BigHorn has excellent stack effect, which makes the natural ventilation very effective and eliminates the need for conventional air-conditioning.

Oberlin uses EMS-controlled windows for the atrium and second-floor hallway to provide natural ventilation to the atrium and corridors. Manually operated low windows in the classrooms can also provide limited natural ventilation.

TTF had no natural ventilation provisions, although there was design intent to have some natural ventilation. The design intent of TTF was to use a high relief damper to release hot air from the building. However, during construction, this damper was installed much lower than desired, which renders the natural exhaust system ineffective.

Active cooling was provided at Oberlin and CBF for backup if natural ventilation was not effective or could not meet all the cooling loads. Natural ventilation (or natural ventilation coupled to cooltowers) provides all the cooling at Zion and BigHorn. The only metric for measuring the performance of the natural ventilation is the comfort in the spaces: if the occupants are comfortable, the natural ventilation system is considered successful.

Table 3-8 Natural Ventilation Controls in High-Performance Buildings

Building	High Window Control	Low Window Control	Active Cooling
Oberlin	EMS in north clerestory	EMS in atrium, with manually operated windows in classrooms and offices	Yes
Zion	EMS	Manual	No
Cambria	None	None	Yes
CBF	EMS	Manual (EMS indicators)	Yes
TTF	Relief damper (EMS)	none	Yes
BigHorn	EMS (with manual override)	Manual (doors)	No

3.3.4.1 Natural ventilation can provide significant fan and air-conditioning energy saving

The natural ventilation systems at Zion and BigHorn were mostly successful, providing all the outdoor and cooling requirements (Zion's cooltowers are an evaporative cooling system driven by natural ventilation). Savings were realized by not using fans to provide outdoor air to supply ventilation air or conditioned air. When combined with evaporative cooling, the energy savings were even greater, eliminating all fans and conventional air-conditioning equipment. Limited success was observed at CBF, as the system typically operated in hybrid mode with exhaust fans. The natural ventilation system is a hybrid or mixed-mode system in that fans are often used to help move ventilation air. These fans exhaust air on the north side. A fan on the second floor exhausts air at a rate of 2,800 cfm (1.32 m³/s). A fan on the first floor exhausts air at a rate of 5,600 cfm (2.64 m³/s). Minimal natural ventilation is used at Oberlin because of difficulties developing and implementing appropriate controls.

3.3.4.2 Natural ventilation should be designed to rely primarily on stack effect

Oberlin's and BigHorn's natural ventilation systems were designed to operate primarily on the stack effect, driven by temperature differences between warm air inside and cool air outside. The warm air in the room rises and exits at the ceiling or ridge, and enters via lower openings in the wall. At Zion, natural ventilation is combined with evaporatively cooled air, designed to operate by stack-driven temperature differences.

The natural ventilation at CBF was designed to take advantage of prevailing winds off the bay that flow from south to north, as shown in Figure 3-25. The design of the building's operable fenestration and intended natural ventilation airflow pathways were based on a single wind direction. Low- and mid-height windows on the south side are grouped in banks of four and operated with hand cranks. Windows high on the north side have motorized operators that are controlled by the building's EMS. In reality, this system has limited functionality because the wind direction is very changeable. Measured data confirmed that winds in the area tend to flow from the northwest when outdoor conditions are good for natural ventilation. They also come from the east as often as from the south. The monitoring data show that designers should not have assumed that the winds from the south (off the bay) would be the most important winds for natural ventilation cooling. Although winds do not come from the north, designing for cross ventilation in the east to west and west to east directions would have been an improvement. The discrepancy between expected and measured wind directions also suggests that engineered natural ventilation systems should be designed to operate by stack forces rather than by wind. Winds are important resources for daytime, natural cross ventilation. For CBF, passive cross ventilation should have been designed for multiple airflow paths and natural stack effect.

Natural ventilation should be designed to rely primarily on stack effect unless wind direction and speeds are reliable and well understood. Even with reliable winds, passive cross-ventilation should be engineered for a variety of airflow pathways and wind directions.

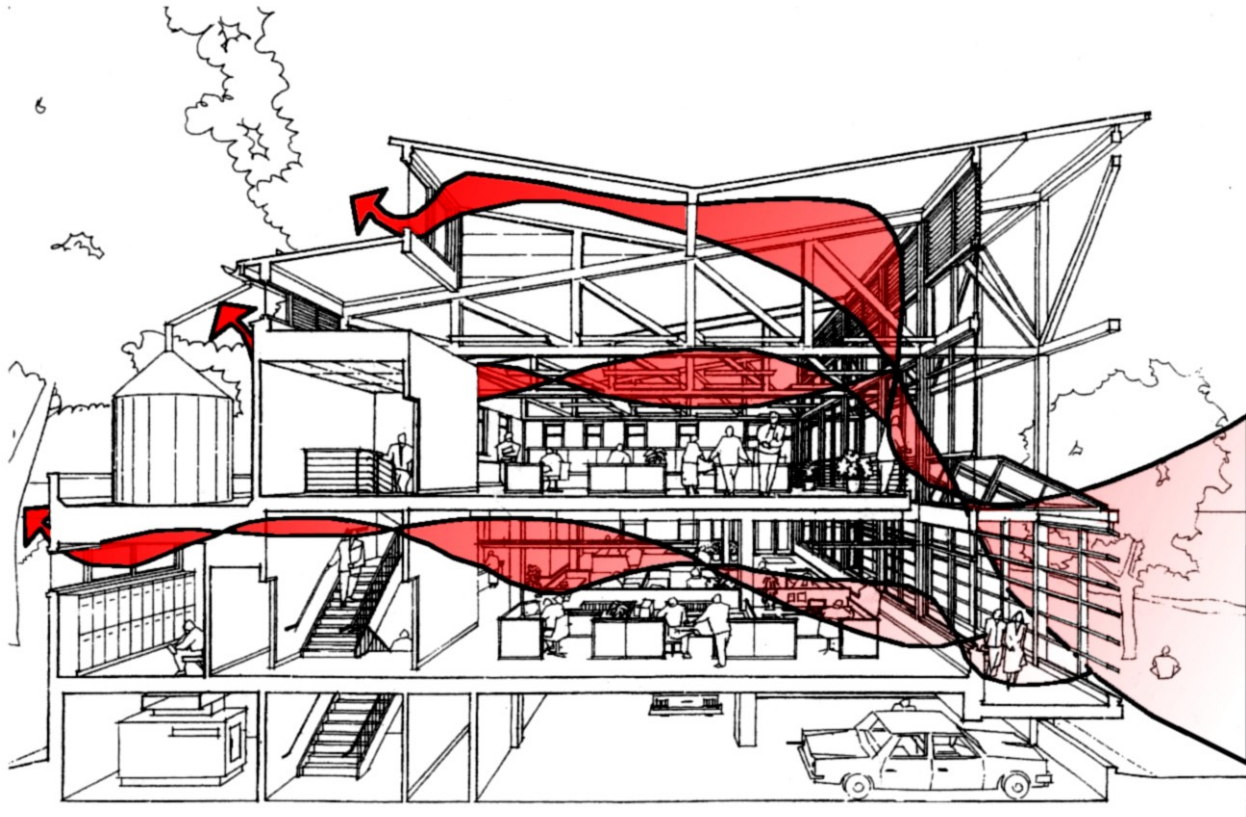

Figure 3-25 Intended airflow pathways for natural ventilation from the design phase

3.3.4.3 Separate natural ventilation supply and relief from the fenestration and use relief dampers for the passive ventilation

Operable windows form an important part of the natural ventilation systems at Oberlin, CBF, Zion, and BigHorn. The windows near the ground at Zion and CBF are operated manually; clerestory windows are on automated actuators. Experience showed that occupants do not consistently operate the manual windows. In addition, windows are not considered typical HVAC equipment, so how the operable windows interface with the controls system was an issue in all cases. Commercial-grade window actuators were used at Zion, Oberlin, and CBF. Motorized window actuators were prone to failure. Custom wiring and control algorithms had to be developed to operate the windows. The EMS does not know when the windows are fully open or closed and does not shut off power to the device. The windows at Zion are cycled once daily in the summer to help ensure they are synchronized with the status as indicated by the EMS. Using dampers with typical HVAC control actuators would reduce maintenance and integration issues without reducing natural ventilation performance.

Operable windows require more frame area than fixed windows, and the screens reduce both the effective open area and the visible transmittance important for the daylighting. In addition, the operable windows have very little open area when “fully open,” as the actuators were limited to about 6 in. (15 cm) of throw.

Based on these lessons learned from the natural ventilation system at Zion, residential window actuators were specified at BigHorn. No actuator problems have been reported with this application. The operable windows are on the north side of the clerestory to minimize the effects of the screens and the larger frame area on the daylighting.

3.3.4.4 *Use automatically controlled supply and relief controls that do not rely on occupant interaction*

The occupants of commercial buildings do not interact consistently with the windows as a natural ventilation control strategy. EMS typically control operable windows better than occupants do for natural ventilation purposes. For example, the operable lower windows at Zion are often not opened, even when outdoor conditions are favorable. Whether the problem is the height of the windows, security concerns, or lack of interest, the bottom line is that the windows are not opened.

CBF experienced some of the same issues. Low- and mid-height windows on the south side are grouped in banks of four and operated with hand cranks. Windows high on the north side have motorized operators that are controlled by the EMS. Figure 3-26 shows a photograph of one of the signs in the office areas that reads “Open Windows.” It is used to inform occupants when conditions are appropriate to open the manually operated windows. Even when the EMS indicates to open the windows, occupants do this only occasionally. Interest in operating them has waned somewhat since the building first opened. There was more enthusiasm to work with the windows when the building was new.



Figure 3-26 Signage at CBF directs occupants to operate windows

At Oberlin, the HVAC system must be manually switched off when the classroom windows are manually opened. Provisions must be made to ensure HVAC systems do not turn on during natural ventilation operation. Experience shows that occupants do a poor job of operating the manual windows. Additionally, occupant control of windows can cause the HVAC system to operate when the windows are open.

3.3.4.5 *Provide multiple opportunities for passive airflow*

Carefully design interior partitions, floor plan, and fenestration to promote good circulation of naturally induced airflow and limit passive airflow disturbances. Enclosed spaces tend to overheat because of insufficient airflow caused by naturally induced low-pressure ventilation.

As a special class of passive natural ventilation, the use of cooltowers requires careful design of interior partitions and fenestration to promote good circulation of cooled air. The enclosed offices at Zion tend to overheat because of insufficient airflow and continual heat gains from the Trombe wall. Exhaust fans

originally installed in the office area were not sufficient to move air through these spaces to counteract the heat gains from Trombe walls. As with many passive systems, moving air mechanically should be avoided.

At BigHorn, the private offices on the mezzanine often do not receive enough natural ventilation. During design, the suggestion was made to add windows as high as possible to the office wall to use shared light from the clerestory windows. These windows would also allow ventilation air to circulate by natural convection. This suggestion was not incorporated and the offices require additional lights and fans during the summer to move the stuffy air.

3.3.4.6 Natural ventilation systems should not replace conventional economizers

One way to think about passive natural ventilation is that it essentially economizes without fans, and, if it is fan assisted, it is much like running an economizer. However, from a thermal comfort point of view, it is limited to moderate temperatures and humidity. An economizer-based system can control supply air temperature to provide thermal comfort for a wider range of outdoor temperatures.

In practice, the natural ventilation at CBF is often operated as a hybrid system with the aid of exhaust fans, which run a significant amount of the time. The system essentially fits the role of an economizer, but without the controlled air distribution provided by ductwork and registers or the control afforded by controlling air temperature through mixing. This mode of hybrid operation could be more efficient because of lower static losses. The exhaust fans are used in the winter when the windows are closed and makeup air comes from infiltration. This type of system operation makes up for the lack of economizer operation. However, an economizer would be better because it is controlled to a mixed air set point and could be expected to provide more uniform comfort. The issue is that potentially cool air is not mixed with space air and cool drafts are felt. Infiltration does little to ensure that cooling effects are evenly distributed; it also increases static pressure, which causes the exhaust fan to work harder. Further analysis also found that considerable energy is being expended for heat pump cooling during the swing seasons and the winter, which indicates that natural ventilation systems do not always deliver cooling during the heating season. Measured data allowed NREL to examine how much of the cooling energy is consumed when outdoor air conditions would be favorable for economizer operation (were the building to have this feature). For this examination, we sorted and summed HVAC cooling energy use for times when the outdoor air temperatures fall below 58°F (14.3°C). The analysis revealed that of the 71.4 MWh of electricity used for cooling, 15% was used when the outdoor temperatures were favorable for economizer use and not for natural ventilation use.

3.3.5 Evaporative cooling and cooltowers

3.3.5.1 Use evaporative cooling systems in dry climates

All cooling requirements were met with evaporative cooling systems in the dry climates at Zion and TTF. In a dry climate, direct/indirect evaporative cooling can provide sufficient cooling capacity with less energy use than refrigerant-based cooling systems. The TTF uses a direct/indirect variable speed supply fan evaporative cooling system, and Zion uses a passive downdraft cooltower system, which is functionally equivalent to a direct evaporative cooling without fans.

The TTF evaporative cooling system was designed to meet the building's normal cooling loads and keep humidity levels within the comfort range without conventional cooling coils. Figure 3-27 diagrams the main air handler. The main supply fan is variable speed and rated for 10,500 cfm (4,956 L/s). The evaporative cooler is a two-stage, direct/indirect unit sized for an airflow rate of 10,000 cfm (4,720 L/s). The direct section of the evaporative cooling unit has a rated effectiveness of 90%; the indirect portion has a rated effectiveness of 75% (S.A. 1993). Air for the secondary side of the indirect section is drawn from the building and then exhausted outside using a 5,300-cfm (2,501-L/s) variable-speed fan. The evaporative cooling system is equipped with two, 0.16-hp (0.12-kW) water pumps to wet the cooling medium. Separate pumps allow for independent control of the two evaporative stages.

The TTF main air handler is used only for cooling; it is turned off when cooling is not needed. There are four different operating modes for the air handler: (1) economizer, (2) direct evaporative cooling, (3) direct/indirect evaporative cooling, and (4) indirect evaporative cooling. When outside conditions are favorable, the air handler meets cooling loads by economizing where outside air and return air (drawn from the east mid-bay) are mixed to meet a control supply temperature.

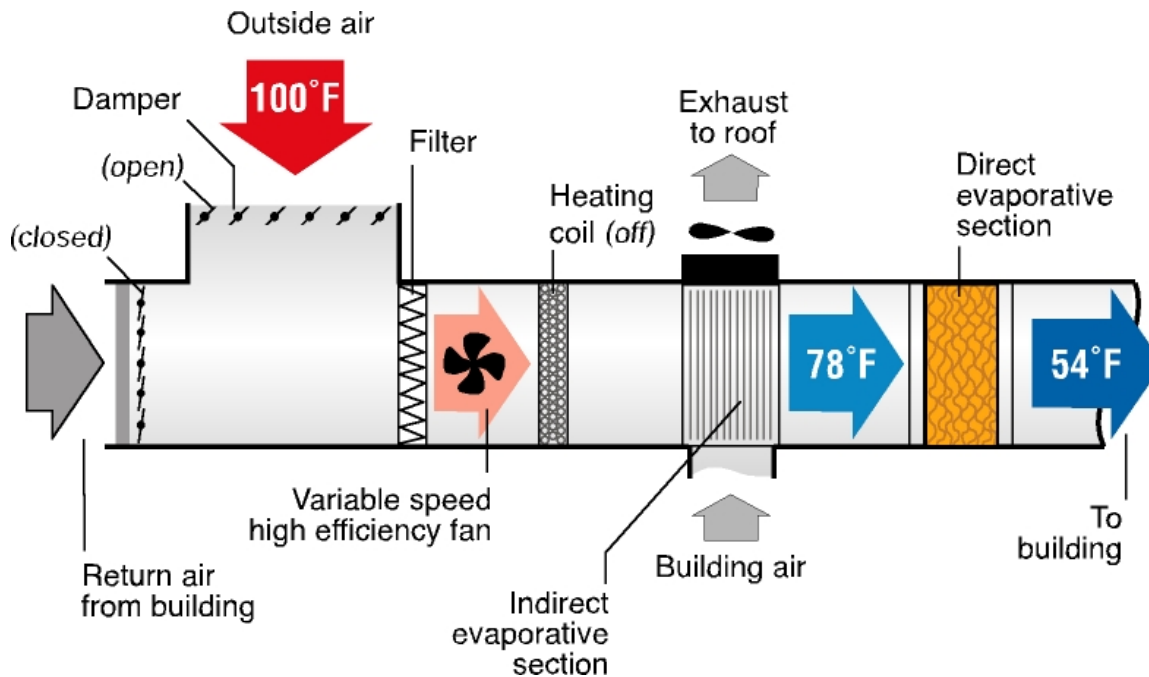

Figure 3-27 Main air handler with direct/indirect evaporative cooling

Reducing the cooling load daylighting and enhanced envelope and then meeting the remaining cooling needs with the evaporative cooling system had the second-largest impact on TTF's total energy savings. The cooling load energy cost was reduced by 77% compared to the baseline model, which saved \$480 in annual cooling energy costs. The main contributors to the saving were daylighting, which reduced the internal gains from operating electric lights, and overhangs on south-facing windows, which block direct solar gains during the cooling season. Additional savings were achieved by using a two-stage evaporative cooler.

Even though more fan energy use and airflow were required for the TTF evaporative cooling system, overall the system still saved significant energy costs. An advantage of using a 100% outdoor air-conditioning system at TTF is that the system flushes the building and can handle very large loads (and variations of loads) that can be part of laboratory experiments. This would have been difficult with a traditional cooling system unless it were sized for 100% outside air.

Both TTF and Zion evaporative cooling systems run all the time on hot days. This leads to issues about the comfort expectations of these systems. Although the buildings are maintained at ASHRAE comfort standards, the buildings are cooler in the mornings and warmer in the afternoons. Recovery from a mechanical or control issue can take 24 hours.

3.3.5.2 *Cooltowers work as well as a direct evaporative cooling system*

The Zion cooltowers function in two stages. The first stage occurs when the clerestory windows open and natural ventilation cools the space. When natural ventilation is inadequate, the first stage is augmented by

using the cooltowers to further reduce indoor temperature (second stage). We designed the cooltowers to operate on natural convection driven by buoyancy forces and prevailing winds. The cooltowers have evaporative cooling pads on all four sides at the top and large operable shutters on all four sides at the bottom. Air is cooled by pumping water over the evaporative cooling pads. This cool, dense air “falls” through the tower and exits through the large openings at the bottom of the towers, as shown in Figure 3-28. The cool air drawn into the building by the cooltowers causes the hot air inside the space to rise and exit the building through the open clerestory windows.

There are no fans in either tower. The only energy required for each tower is a 1/3-hp (249-W) pump for water circulation to the evaporative pads. The building’s energy management computer controls the operable clerestory windows, shutter doors, and pumps. The shutter doors on the exterior of the building were intended for cooling the patio area, but they are rarely used because the air entering the patio area dissipates quickly and is not effective. In addition, using the exterior doors degrades the interior performance. Figure 3-29 and Figure 3-30 show the installed towers from outside and inside the building.

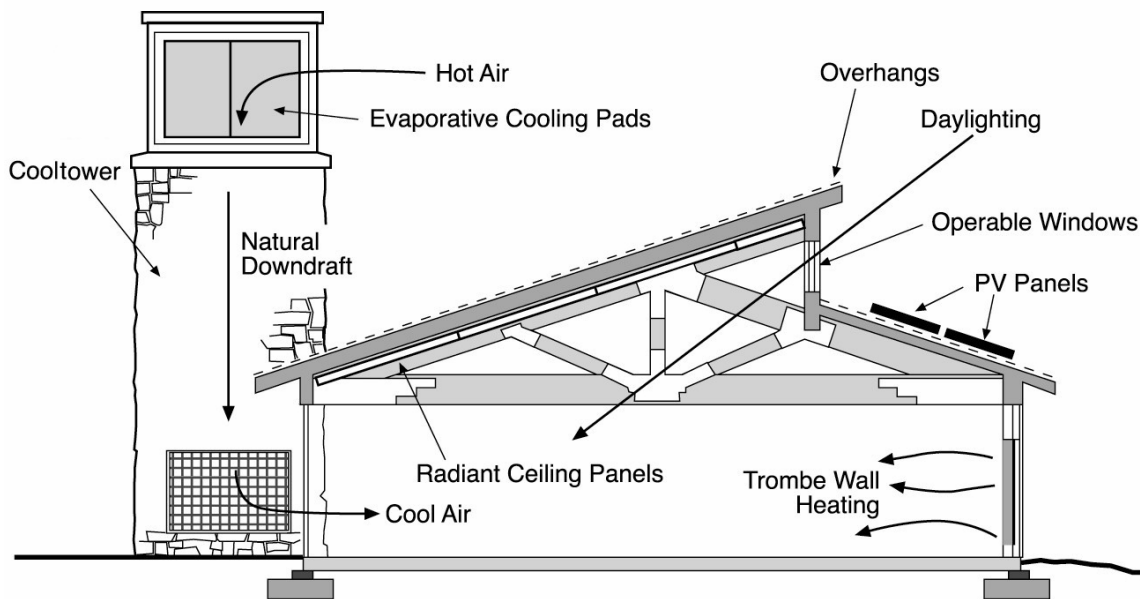

Figure 3-28 Illustration of how the cooltowers work at the Zion Visitor Center

Ceiling fans, controlled by the EMS, are in the main zone of the Visitor Center and in the break room. The fans are controlled based on zone temperatures, and help to keep air moving. We put small fans in the offices to provide additional circulation if needed. These fans exhaust air from the office and dump it into the exhibit area. During the winter, the cooltower doors are closed.

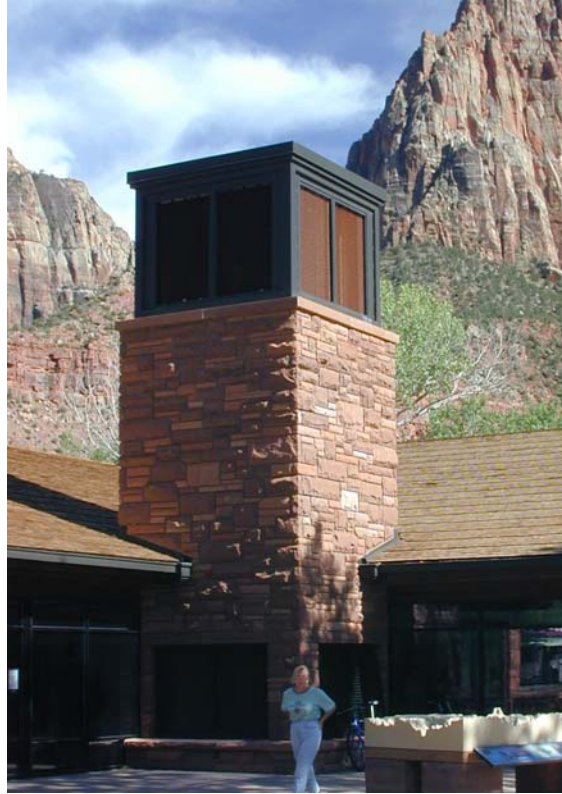

Figure 3-29 Natural downdraft cooltowers—exterior view



Figure 3-30 Interior view of a cooltower showing operable shutters that allow cool air to enter the building through the bottom louvers

The natural ventilation and cooltowers have provided adequate cooling for the Visitor Center Complex, with occasional periods of overheating and low flow rates. The Zion cooltowers work as well as a direct evaporative cooler. There were periods when the cooltowers could not meet the desired comfort range. This is typical of direct evaporative cooling. The system requires discharge into open areas because of the very low pressure drops. It does not work well in the enclosed offices at the fringe of the building.

Floor fans that blow air into these spaces have provided some relief. The problem is compounded with the Trombe wall summer gains (see Section 3.3.3). There are no issues with the Trombe wall and its interaction with the cooltowers in the open spaces. The building probably could have used a tower in the enclosed office area of the building, but it was eliminated during the design.

The cooltowers produce more than 1.5 cfm/ft² (7.6 L/s/m²) of evaporatively cooled supply air, which is comparable to a fan-forced system. Measured airflows from each tower are approximately 6,000 to 8,000 ft³/min (2,382–3,776 L/s) during typical operation. (This number is only an approximation because of measurement difficulties for very low-pressure systems.) The cooltowers cool the Zion building with only a small water circulation pump and circulation fans that help push cool air into the enclosed office areas of the building. The cooling energy intensity was 1.28 kBtu/ft² (14.5 MJ/m²), which was 77% less than a typical building in the western United States that uses 5.5 kBtu/ft² (62.5 MJ/m²) (EIA 2005a). The cooltower in the comfort station works very well, as exact control is not needed.

3.3.5.3 Provide multiple opportunities for passive airflow

As a special class of passive natural ventilation, cooltowers require careful design of interior partitions and fenestration to promote good circulation of cooled air. The enclosed offices at Zion tend to overheat because of insufficient airflow and heat gains from the Trombe wall. Exhaust fans originally installed in the office area were not sufficient to move air through these spaces to counteract the heat gains from Trombe walls. As with many passive systems, moving air mechanically should be avoided. The Trombe wall is shaded in the summer, but the diffuse component of the solar radiation still heats the wall. In the initial building design, the Trombe walls were to be adjacent to open spaces, not to the enclosed offices. Late in the design process, the interior layout of the building was changed to place enclosed offices on the south side of the building adjacent to the Trombe walls. Even in the winter, this Trombe wall provides more heat than needed to the office spaces. As a result, circulation fans were installed between the public and private spaces to help induce additional air flow. These fans improved the comfort of the office spaces; however, they also increased the fan energy use and noise.

3.3.5.4 Consider water use in an overall assessment of evaporative cooling systems

Evaporative cooling systems use large quantities of water. The implications of water consumption for evaporative cooling versus water used at a power plant to generate electricity need to be factored into an overall assessment (Torcellini et al. 2003). Water consumption is a concern because of the semi-arid climate and the scarcity of water resources. From the installed water meters, 111,200 gal (420,938 L) of water were consumed during 2002 for the two cooltowers in the Visitor Center. Flaws in the design of the cooltower plumbing resulted in unnecessary water use, which occurred when the sump pit would overflow during on/off pump cycling. The pump cycling and sump pit overflow resulted in a 10% increase in water consumption. The cycling occurred during the swing season when the cooling was not required all the time. During this time, the pumps would run and saturate the pads and the sump pit would fill. The pumps would turn off because cooling was no longer needed and all the water in the pads would drain into the full sump pit and cause the pit to overflow.

Another measure of cooltower success and excess water consumption is the effectiveness of delivering the evaporative cooled air to the building. By design, the dry air enters the building and picks up moisture. However, some of the air may exit through the pads into the environment driven by evaporation on the exterior of the pads or cross-flow through the top of the tower, which results in more evaporation than would be expected with traditional evaporative technologies. The towers contain a simple internal diagonal blocking device to minimize this effect (see Figure 3-31).

No shading was designed into the cooltowers to shade the medium from direct exposure to sunlight, which increases the evaporation rate. Although the consequences were not quantified, researchers suspect that solar shading would reduce water consumption. The shading also reduces UV degradation of the media surface and the visible dissolved solids that accumulate on the exterior of the surface.

As an estimate, based on in-situ airflow, temperature, and humidity measurements, 50% of the total water used in the cooltowers is not used to cool the building. Much more detailed measurements are needed to validate and fine-tune this number. It does result in the conclusion that the efficiency of the towers should be improved with respect to water consumption.



Figure 3-31 Plastic blocking device for cooltowers

3.3.5.5 Verify installation and equipment quality of evaporative cooling systems

Both the TTF and Zion evaporative cooling systems had setup problems related to the quality of the equipment and the installation. Evaporative systems must be designed for proper maintenance. The Zion system had problems with the size of the sump pit, the size of the drain lines, and the design of the frame holders, which allowed leaves to collect. The cooltowers trays that collect excess water extend about 1.5 in. (3.8 cm) beyond the cooling medium. Leaves are caught in the trays and then migrate past the cooling medium at the corners and enter the water circulation system. The bleed valve has clogged on occasion because leaves collect in the system. Although improved details may reduce the debris, the water circulation system needs to be robust enough to handle it. Drains were poorly detailed and undersized, which resulted in overflows. To avoid wasting water, systems should be sized to avoid overflows. The cooltowers include a sump pit that was sized too small to hold all the in-transit water. The installed sump pit has a 20-gal (76-L) capacity. The trays and media, when wetted, hold about 20–30 gal (76–114 L) of water, which enables about 10–15 gal (38–57 L) of water to overflow the drain when the pump cycles off. This water is made up with fresh water when the pumps turn back on.

The TTF evaporative cooling unit underwent many alterations to improve its efficiency and reliability. When the building was first occupied, the cooling system did not operate properly. The engineer responded that an evaporative system could not meet the load; however, NREL staff monitored the system and observed that the unit's performance was significantly lower than specified by the manufacturer. Finally, NREL staff dismantled the unit to find that the direct section was not plumbed properly and the cooling medium was not wet. Only a small amount of the cooling medium was being hit with pumped water; the rest was completely dry. Although the direct suction pump operated normally, the nozzle responsible for spraying water onto the evaporative medium was never properly attached. The

investigation was complicated by the fact that the medium was not accessible as indicated in the specifications. This inaccessibility affects maintenance and commissioning of the building.

The TTF's evaporative cooling unit's drain pan failed. The on-site fabricator of this drain pan used steel bolts to attach the pan to the evaporative unit. These bolts rusted through and resulted in a substantial leak. Although the mechanical room is outfitted with drains, expansion joints in the floor were located between the pan and the drain. Water leaked to the floor below the mechanical room and caused some damage to the copy room and restrooms. Stainless steel bolts and a replacement seal were used to repair the drain pan. All these failures can be attributed to system design—units such as these should be factory assembled and tested. None of these failures are attributed to the direct/indirect technology, which was successful in this building.

3.3.5.6 Use outdoor air for the indirect section of an evaporative cooling system

Several improvements could be made to the TTF's evaporative cooling system. The indirect part of the system currently scavenges air from inside the building, but using outdoor air would be better. Because the TTF has a built-up central air handler, using indoor air was simpler than using outdoor air because it involves less ducting. However, the outdoor humidity is usually lower than that inside the TTF because of the direct evaporative cooling and process loads (especially when the desiccant test loop is operating). The indirect evaporative section would likely be more effective with outdoor air. The air handler draws outdoor air from the south side of the building, which is preheated by the roof. The air would be cooler if it were drawn from the north side. The evaporative cooler control is currently based on dry-bulb temperatures; more sophisticated controls based on a real-time psychrometric analysis of the various air streams could improve the determination of the most efficient means of cooling. They require minimal maintenance if drains are properly sized from the pads, pad trays are designed so that debris will not clog them, and pads can be examined and replaced if necessary.

3.3.6 Ground-source heat pumps

3.3.6.1 Carefully size heat pumps and ground loops

Ground-source heat pumps with ERVs are the primary heating and cooling sources at Oberlin, CBF, and Cambria, and each heat pump system had performance issues related to either equipment or ground capacity sizing.

The Cambria heat pump system has a slow response time, which results in small temperature setbacks and long startup periods. The heat pump cooling capacity is 54 tons (189 kW), which may be slightly undersized because it takes a long time to recover from a setback. This situation is compounded by the control of the ERVs, which should not be used on cold winter mornings until occupants arrive, and could be used in warmer weather to help cool the building before occupants arrive.

A study of the effectiveness of the under-floor air distribution system at Cambria was completed by Lawrence Berkeley National Laboratory researchers in 2004 (Fisk et al. 2004). They found that the air change effectiveness was about the same as a zone with well-mixed air, but the pollutant removal efficiency for CO₂ was 13% better than expected in a zone with well-mixed air. The thermal stratification in the zones during cooling mode operation was only 2°F–4°F (1°C–2°C) between just above the floor and the return air registers. This low thermal stratification is caused by higher than necessary supply airflow rates and low internal gains (partially occupied building). The thermal stratification would probably increase if the building were fully occupied or if there were a variable air volume system that reduced airflow with reduced zone loads. Thermal stratification is desirable because it can lead to energy savings during cooling.

Based on the measured energy performance, the CBF ground well field may be undersized for the actual loads. This lesson stems from findings from the CBF analysis that shows temperatures in the ground loop fluctuate widely and are often higher than expected. The sizing calculations should be redone to include

the unused desiccant dehumidification system. Finally, follow-on efforts should verify that the field has been installed as designed and that all wells have the appropriate flow rates.

The monitored data also provide a way to compare the ground-loop supply temperatures to the outside air temperature. The temperatures of heat sinks largely determine the thermodynamic efficiency of heat pump cooling. The purported advantage of a ground-loop arrangement that uses water-to-air heat pumps over rooftop packages with air-to-air direct expansion mechanical cooling is that ground-loop temperatures are expected to be lower than air temperatures and lead to more efficient cooling. NREL analyzed this assumption at CBF by comparing the ground loop and outdoor air temperature data for the model analysis year. We analyzed the data to determine how outdoor air dry-bulb temperatures compared to the ground-loop temperature. The data show that for 61% of the time, cooling occurred and the outdoor air was actually cooler than the ground loop that supplies the heat pumps. Analysis of energy use shows that of the 71.4 MWh of electricity used for cooling, 42% was used when the outdoor temperature was cooler than the ground-loop supply.

As part of a follow-up evaluation of the CBF ground-source heat pump system, the addition of a cooling tower should be considered. Currently, outdoor air temperatures are cooler than the ground-loop temperatures 61% of the time (mostly during the winter and shoulder seasons) and about four times more heat is added to the ground for cooling than is extracted for heating. With such a California-style heat pump arrangement, the ground-source heat pumps would be used only when ground temperatures are more favorable than ambient conditions. Further analyses should be performed to study the rainwater collection system to determine whether a wet cooling tower would be feasible; otherwise, a dry cooling tower would need no water.

The Oberlin heat pumps were not specified correctly, as they are not rated for ground-source water temperatures. Extended-range rather than standard-range heat pumps at Oberlin would have been the proper system for ground-source water temperatures. The installed standard range heat pumps typically operate outside the recommend ground-source water temperature range. In addition, a backup electric boiler is needed if the standard range heat pumps need additional capacity. Specifications for heat pumps must work with appropriate ground water temperatures. Appropriately rated ARI-330 ground-source heat pumps would increase the operational efficiency and provide operational capacity (ARI 2003).

3.3.6.2 Use models with short-term response when designing ground-source heat exchangers

Ground-source heat exchangers and heat pumps have been promoted for low-energy buildings. Experience with the CBF ground-source system indicates that although the system can deliver good space comfort, temperature fluctuations in the ground loop are wider than expected. Monitored data for fluid temperatures that return from the ground heat exchanger clearly show that loop temperatures can be high and show considerable seasonal and daily fluctuations. When modeling is used to design such systems, the models typically use constant fluid temperatures for each month. Although such analysis attempts to ensure that the field can perform over a long period (years), they do not capture the fluctuation of temperatures over the short term. The next-generation design tools for ground-source heat pumps, such as those now available in EnergyPlus (EnergyPlus 2005), should be applied as these systems are evaluated and designed.

3.3.6.3 Provide for part-load groundwater pump control

VSD pumps at Oberlin and CBF circulate the glycol-water mix through ground wells and to the heat pumps. The ground-loop pumps are controlled to provide a constant pressure difference between the water supply and return. As various heat pump packages cycle on or off, that portion of the water loop is opened or closed, which affects the pressure. When there is no demand for the ground-source loop, the VSD controls the pumps to 5% of full rated pump power. The groundwater circulation pumps at Cambria are mounted in series to match the flow and head requirements of each heat pump. This configuration is not the most efficient, but it is often used because pump sizes may have limited availability and many contractors want to use only one type of pump. The pumps are rated at 230 W each, but they were

measured to draw approximately 200 W each. The pumps run continuously; however, they need to operate only when the compressor is running. There was a concern that the capacitance effects of the ground might adversely affect the system when the pumps run in a cycling mode. According to a study done by Kavanaugh and Rafferty (1997), this is not a concern, and the best method of operating the circulation pumps in this configuration is to tie them to the compressor operation. A conservative estimate is that the compressors run an average of 50% of the time. The annual saving of linking the pumps with the compressor operation would be 18 MWh and approximately \$1,300.

As part of this recommendation, the control algorithms for VSD ground-loop pumps should be examined. Perhaps loop pump flow should be controlled based on supply temperatures (or temperature differences) with limits set by pressure. Such research should seek to balance pump energy, ground heat exchanger effectiveness, and heat pump efficiencies.

3.3.7 Energy recovery ventilators

ERVs were designed into the HVAC systems at Cambria, CBF, and Oberlin to recover energy from exhaust air to preheat or precool supply outdoor air. ERVs are often used to save energy required to condition incoming air. A properly controlled ERV can realize energy savings; the same ERV improperly controlled may actually increase energy use and cost.

3.3.7.1 ERVs should be designed in conjunction with economizers

Commercial buildings need a mechanism to utilize outdoor air for “free cooling”, especially when outdoor air is 50°F–70°F (10°C–21°C) and the building needs cooling. In this range, ERVs provide minimal heat recovery and add energy to systems that should use less energy. Design teams view ERVs as big energy savers and discard well-proven economizer concepts. Cambria, Oberlin, and CBF all had ERVs with no economizer cycle and high swing season loads.

ERVs should include bypass dampers to use outside air for cooling for economizer operation without the overhead of the ERV fans. A schematic of an outdoor air heat pump system with an ERV bypass is shown in Figure 3-32. At Cambria, a conservative outdoor air temperature range for not operating the ERVs is 50°F–60°F (10°C–16°C), which represented about 13% of the weekday hours between 5:00 a.m. and 5:00 p.m. in 2002 and 2003. Above 55°F (13°C), the heat pumps may have to provide some cooling, but the ERV fans would not have to be used. Above 60°F (16°C), the outside air may have high moisture levels that would have to be removed by the heat pumps. Enthalpy control on the economizer would expand the economizer operation range and provide more hours for using outside air for cooling, although caution must be used with this option as enthalpy controls often are not reliable. Standard 90.1-2004 (ASHRAE 2004) specifies economizer types for climates and HVAC systems.

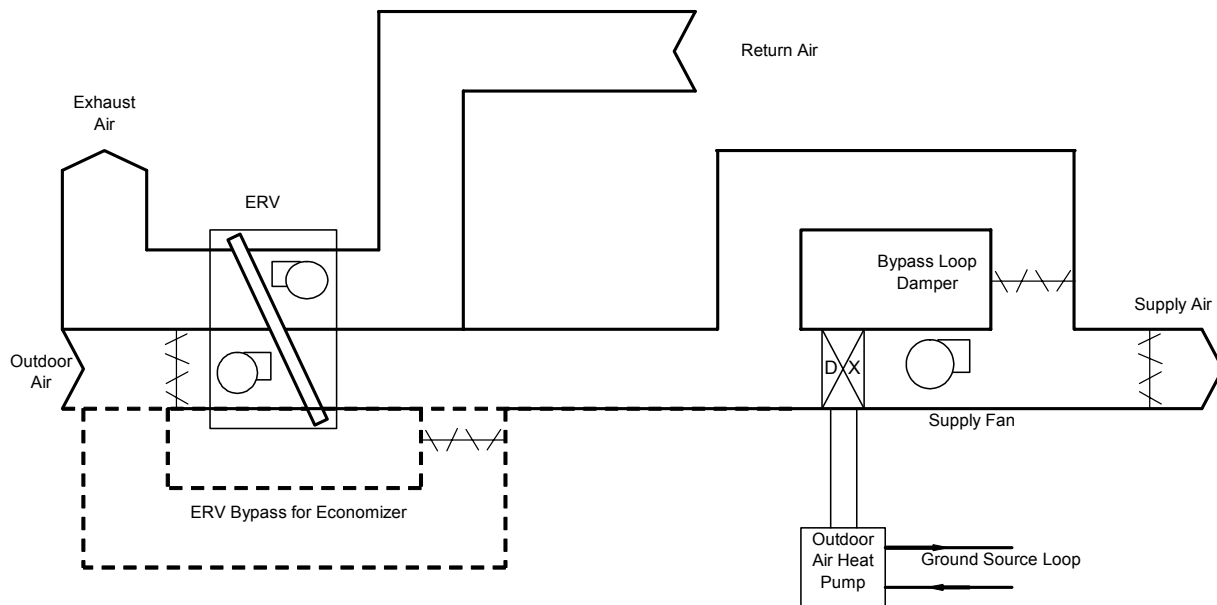

Figure 3-32 Heat pump outdoor air system with ERV bypass for economization cycle

The energy recovery desiccant wheel dehumidification system at CBF is not used as designed and its potential benefits should be evaluated. If the wheels are not going to be used, they should be removed because they increase the pressure drop and fan energy used to provide fresh air. One option is to use the wheels in a heat recovery mode without using the desiccant regeneration coil. If the wheels are retained for use and an economizer system is added, the air handler should be reconfigured to allow the wheels to be bypassed during economizer operation to minimize fan energy.

3.3.7.2 Control ERVs to recover energy only when it is a net saving to the building and when outdoor air is needed

ERVs can represent one of the largest factors in HVAC energy use. The ERV fans consume a considerable amount of fan energy to bring in large amounts of outside air, which must be conditioned. The first step in reducing energy use associated with outdoor air should be a demand-responsive ventilation system in conjunction with an economizer cycle that supplies outdoor air only when and where it is needed. An ERV that operates continuously can result in significant fan energy use. In addition, it may recover energy when outdoor air is not needed, thereby increasing heating or cooling energy use. ERVs integrated with a demand-responsive ventilation system can then save further energy when outdoor air is needed, contingent on an economizer cycle and controls that allow for appropriate operation.

The Cambria ERVs initially provided outdoor air continuously. They were reprogrammed to run only during occupied hours, which reduced the fan and heat pump energy required to condition the extra outdoor air. This simple control change resulted in an estimated 13% energy savings as shown in Table 3-9. In addition, the ERVs at Cambria are more than twice as large as they need to be for outside air requirements. Reducing the ERV flow rate by one-half would reduce the fan energy consumption to about one-eighth of its current value because fan power is related to the cube of the fan flow rate. Additional savings could be achieved with a demand-responsive ventilation system that supplies outdoor air only when needed. A similar outdoor air system would also be effective at Oberlin.

Table 3-9 Cambria Energy Impacts of Changes to the ERV Control

Model	Annual Energy (MWh)	Annual Energy Cost	Energy Savings	Cost Savings
As-Built Model	344	\$35,473		
As-Built Model with ERVs running continuously	397	\$39,737	-13%	-\$4,260
As-Built Model with ERVs replaced by airside economizers	315	\$32,533	8%	\$2,940

ERVs effectively precondition outside air, but should be used only if the recovered energy is greater than the energy required to operate the ERV unit and can recover energy at greater efficiency than the heating or cooling equipment. For example, at Oberlin, the power requirements of the supply fan, return fan, and enthalpy wheel in the ERV were 1.7 kW. As Figure 3-33 shows, the Oberlin ERV uses more energy than it recovers when the outdoor temperatures are 70°F–87°F (21°C–31°C). In addition, the outdoor air heat pump is rated at a coefficient of performance (COP) of 3.3. For the ERV to be a net energy benefit, the recovery efficiency has to be greater than the heat pump efficiency. In this case, the energy recovery efficiency is greater than the heat pump efficiency when the outdoor air temperature is less than 55°F–60°F (13°C–16°C); therefore, it should be operated only at outdoor air temperatures lower than this.

A portion of the 1.7 kW that the supply fan motor and enthalpy wheel motor of the ERV consumes is directly added to the supply air in the form of heat, because these motors are located in the supply air duct. This motor placement is beneficial during the heating season, as the heat from the motors is directly added to the supply air stream. During the cooling season, this added motor heat counteracts the cooling energy recovered from the exhaust air. When heat is added to the recovered cooling energy supply, it is only possible to recover more cooling energy than is required to operate the ERV at outdoor temperatures greater than 87°F (31°C).

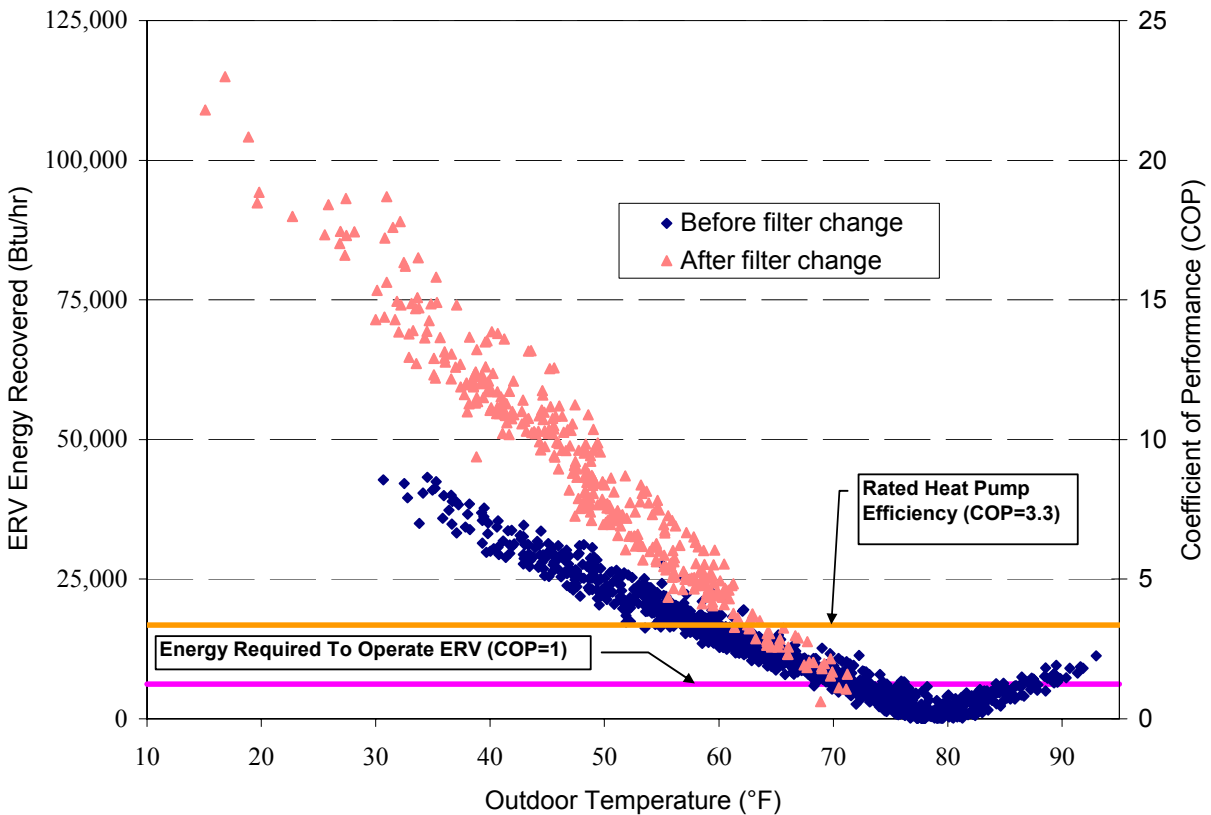

Figure 3-33 Calculated Oberlin ERV energy recovery as a function of outdoor temperature

A properly controlled ERV can realize energy savings; the same ERV improperly controlled may increase energy use and cost. ERVs should not replace proper controls for the amount and scheduling of outdoor air, appropriate equipment sizing, or for conventional economizer cycles. ERV recovery should be used when recovered energy is a net saving and only be used when needed, integrated with a demand-responsive ventilation system with an economizer cycle.

3.3.7.3 Consider energy recovery for all exhaust air streams

The air flow balance between supply and exhaust in an ERV is critical to effective energy recovery. Often, energy in exhaust flows from bathrooms, kitchens, and process loads is not recovered. This can create an imbalance in the ERV unit that limits recovery effectiveness. In addition, the unrecovered energy from exhaust air can be significant compared to the outdoor air flow and reduce the overall energy recovery from a building's exhaust flow.

At Oberlin, we considered the overall recovery effectiveness of the total building exhaust and supply, assuming rated ERV recovery effectiveness and flow rates. The separate exhaust fans in the wastewater treatment, bathrooms, kitchen, and mechanical rooms are rated to exhaust conditioned room air directly outside; this accounts for up to 3,345 cfm (1,579 L/s) with no energy recovery. These exhaust fans create an airflow imbalance in the ERV that diminishes total building recovery capacity. Based on a balance of rated supply and exhaust flows into and out of the building, only half of the potential return air is exhausted through the energy recovery units. The room air that is exhausted through the wastewater treatment, kitchen, and bathrooms has no heat recovery, or a recovery effectiveness of 0.0. Combined, the total rated building exhaust recovery effectiveness is 46%.

ERVs must have balanced air flows for optimal exhaust recovery. This requires that restrooms, kitchens, and other exhaust flows be exhausted through the ERV. This may limit the type or configuration of ERVs used, as they could be staged between wheel types and fixed heat exchanger types to prevent cross-contamination.

3.3.8 *Electric resistance heating*

An electric radiant heating system was used at Zion because it offered several advantages. The Visitor Center Complex buildings require little heat, and a ducted air system was not used for cooling. Therefore, adding a mechanical air system and the associated ductwork for a small amount of heating was considered too costly and complex. We arranged electric radiant heaters to direct heat at the locations where staff would spend the most time. Results show that occupants allowed lower thermostat temperature set points; this is most likely because the radiant heating can provide comfort at lower dry-bulb temperatures. Electric radiant heaters also allow for a more cost-effective and precise temperature control because many thermal zones can be created. Although the electric heaters contribute to demand charges, they are simple to control. The costs of propane and associated transportation were key considerations in the creation of an all-electric building. The key is heating the building without incurring additional demand charges. This decision is highly dependent on the metrics used to measure success. The solution was successful on a cost basis, but was less favorable on a source energy basis.

Electric boilers were originally designed into the hydronic under-floor radiant system at Oberlin. However, the design of the electric boiler hydronic system did not meet the design intent of the rest of the building. This design flaw, combined with original inadequate advanced controls, resulted in the initial limited energy savings and high demand charges. The unstaged 112-kW electronic boiler was replaced with water heating water-source heat pumps. An electric boiler was still used for backup capacity for the ground loop. Electric boilers can be used as a backup source, if they are used sparingly and they do not cause excessive demand charges on the building. Controls and staging are essential to integrate such limited use systems.

3.3.9 *HVAC controls*

3.3.9.1 *Design the control system to be fully integrated with the capabilities of equipment and building operators*

Innovative controls are often crucial to achieving the potential of a low-energy building. In many cases, the energy savings comes from integration of standard technologies—the integration is accomplished with innovative sequencing and control strategies. Not having whole building control algorithms often results in non-optimal performance—that is, buildings that fall short of their design goals. In some cases a low-energy building may have a unique design philosophy and nonstandard equipment and sensors that require special emphasis on designing control systems. A traditional approach to designing control systems may not meet the needs of coordinating HVAC and lighting systems in a low-energy building. For example, the TTF fans inside the fan-powered VAV boxes could not be turned off (these are used for heating, but not for cooling—this can also be considered a specification issue). The human-building relationship must also be considered during design and implemented properly so occupants and operators can interact with the low-energy features.

There are trade-offs in using simple controls versus a complicated, yet flexible EMS. At Cambria, the simple HVAC controls included thermostats on each heat pump. The thermostats are less expensive and easier to program than a centralized control system. However, keeping the time and set points on all of the thermostats is difficult. The current system would work well if one or two people with proper training had access to the thermostats. On multiple occasions innovative systems were not used or optimized because of difficulties in understanding the complex algorithms needed to integrate the systems. For example, at Oberlin, a lack of staging on the electric boilers resulted in significant demand charges. Carbon Dioxide sensors were installed, but not programmed to control outdoor air. Natural ventilation

was designed into the atrium, but never used because of difficulties developing and implementing appropriate controls. In all cases, daylighting controls were tuned to increase lighting savings. In the three buildings with ERVs, controls were changed or changes recommended that would result in additional energy savings.

Using the EMS for data collection was problematic, as discussed in Section 3.7.2.2, but direct access to the building controls was beneficial to researchers for understanding and influencing how the building was controlled. At Zion, researchers had access to and control of the EMS and were able to improve energy management strategies such as implementing and testing various demand-responsive strategies. Access to the EMS allowed us to reduce the demand charges to the building and facilitated continuous commissioning activities. Another advantage of EMS access and control is having a full understanding of the various set points and control strategies to use as inputs into building energy simulation.

3.3.9.2 Budget for postcommissioning controls, tuning, and alterations

The usual commissioning activities do little to improve the operation of a building beyond its design capabilities. Follow-up procedures that are intended to tune, alter, and adjust building operation are equally important. Experience with the TTF shows that after a building is constructed (and has been commissioned to verify its system components are as designed) there is a significant need to adjust or change lighting and HVAC controls to further reduce energy use and improve occupant satisfaction. Predictive capabilities during the design phase are not perfect, and once the building is up and running there should be an opportunity to revisit the design and make changes. Preprogrammed controllers do not always take full advantage of potential energy-saving measures and may need to be reprogrammed.

The obvious expense of postcommissioning tuning and alterations, which for TTF took a “fleet of PhDs” as one engineer commented, suggests the need to develop more advanced control systems to facilitate such activities. The “black box” method of control could work with simple interfaces, if they are designed to maximize the energy saving potential. Robust controllers need to be developed that are related to technologies used in this building—evaporative cooling, daylighting systems, demand-responsive controllers, and variable-speed supply fan systems—for implementation in other buildings.

3.4 Photovoltaic Systems

For the ZEB goal to become a reality, energy production through PV systems on the roofs of buildings will have to produce more energy than the building uses. Future ZEBs will not only require efficient energy use, they will need to maximize energy production. Therefore, lessons learned and best practices related to maximizing PV systems energy output are valuable for future generations of ZEBs. Five of the six buildings in the case studies used PV systems connected to the building’s electrical system to offset electricity use, as shown in Figure 3-34. The Zion PV system is integrated with an uninterruptible power supply (UPS), as shown in Figure 3-35. PV system AC capacities are shown in Table 3-10.

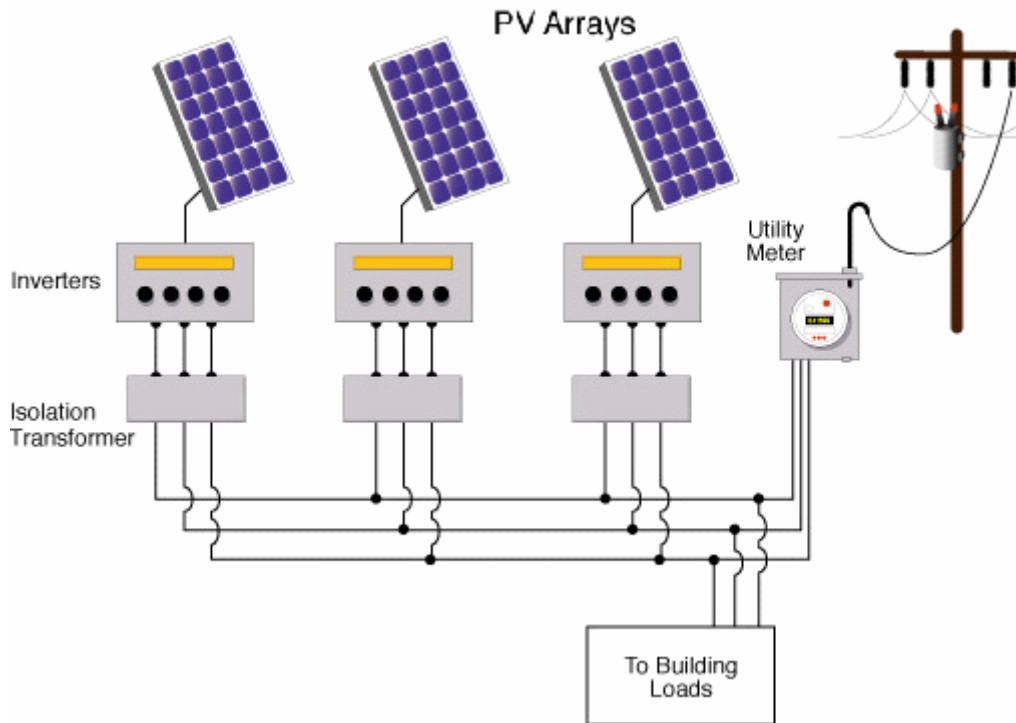

Figure 3-34 Grid-connected PV system configuration with isolation transformers

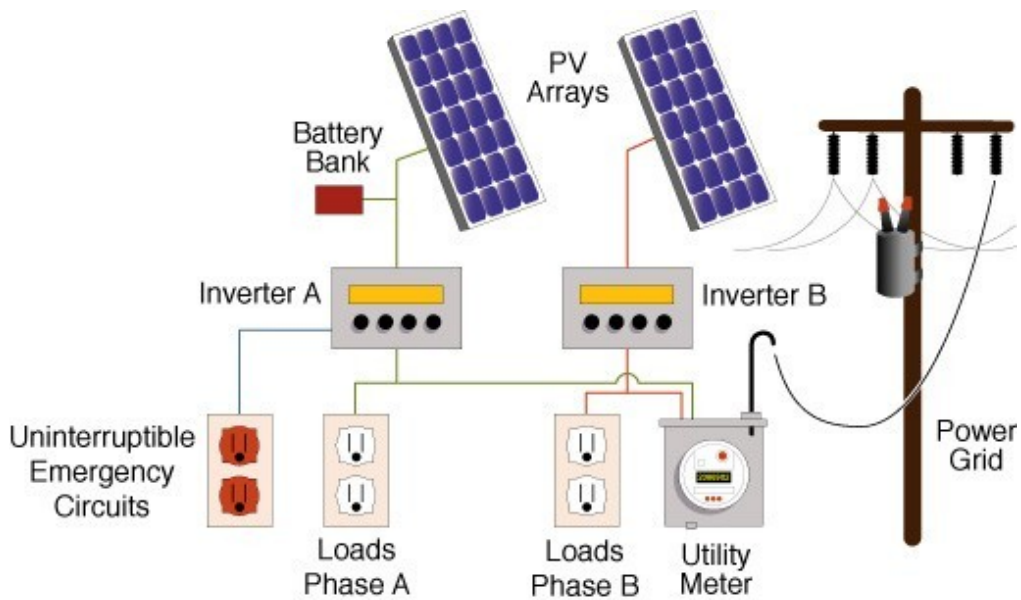

Figure 3-35 UPS grid-connected PV system configuration

For each PV system, we compared measured system performance to predicted performance to better understand the effects of the system failures and sources of performance degradation. We determined expected production without degradation losses in each case. We simulated annual output with measured weather to determine performance with maximum power-point trackers (MPPTs), without shading, inverter faults, or standby losses. Degradation losses, measured output, and expected performance are

summarized in Table 3-10. All systems produced less than expected. Each system output was degraded because of balance of system components or operational problems and shading, which reduced overall output from 14 to 68%. PV system output ranged from 0.43 to 1.09 kWh/W_R.

Table 3-10 PV Systems Performance Summary

		Oberlin	Zion	Cambria	CBF	Bighorn
PV System DC Rated Capacity (kW _R)		60 kW	7.2 kW	17.2 kW	4.2 kW	8.9 kW
Measured Annual Net PV Production (Total PV Production — Standby Losses) (kWh/yr)		55,154	7,861	7,912	2,676	3,800
Measured PV Production per Rated Watt of DC Capacity (kWh/W _R)		0.92	1.09	0.46	0.64	0.43
PV System Standby Use (kWh/yr)		4,364 (7% of total)	minimal	4,647 (37% of total)	minimal	minimal
Significant Performance Degradation Sources	Snow	X		X		X
	Shading		X		X	
	Inverter Operational Faults	X	X	X		X
	No Maximum Power Point Tracking		X			X
	Standby Use	X		X		
Production Reduced due to System Degradation Losses (percent reduction)		14%	19%	56%	48%	68%
Expected Production per Rated Watt of DC Capacity without Degradation Losses (kWh/W _R)		1.07	1.35	1.04	1.22	1.34

3.4.1 Design grid-connected PV systems to have no parasitic standby loads

During nighttime hours when the Oberlin or Cambria PV system was in standby mode, the inverters and transformers consumed electricity. The inefficiency of the isolation transformers in these systems results in a power draw of approximately 300 W per 15 kVA transformer. At Oberlin, this standby parasitic load of the three inverters and isolation transformers was a constant 900 to 1000 W during times of no PV production. The primary purpose of the isolation transformers was to transform the three-phase AC 208-delta output of the inverters to utility-compatible, three-phase AC 208-wye/120. The Oberlin no-load transformer inefficiency of 2% of rated capacity resulted in a standby loss of 4,363.5 kWh/yr, or 7.3% of the total PV production. This does not include transformer losses when the PV system is generating power.

Cambria's inverter faults caused considerably greater standby losses. The causes of the inverter faults were a high AC voltage and high temperature. The high temperature fault was the most severe because the system would have to be manually reset. The inverter was removed and sent to the manufacturer in December 2003 and replaced with a new unit in February 2004. From May 31, 2002 to December 31, 2003, the main PV system produced no energy on 50% of the days because of inverter problems. On many other days the system was operational for only part of the day because of inverter problems. From May 31, 2002 to December 31, 2003, the parasitic load on the PV system equaled 40% of the energy delivered to the building by the main PV system. Most of the parasitic load (37%) occurred when the PV system was down at night or because of an inverter fault; the other 3% were transformer losses during PV system operation. From the time the inverter was replaced on February 20, 2004 to December 31, 2004, the main PV system was down only three days because the whole system was shut down. During this same period, the parasitic load of the isolation transformer was 18% of the total energy delivered to the building. The monthly parasitic load varies from 11% in summer to more than 50% in winter.

If the inverters have near optimal operation throughout the year, nighttime parasitic losses were 7% of the total PV output. With some additional downtime caused by snow and inverter faults, about 18% of the total output is needed for standby losses. A worst-case scenario, 37% of the total PV output was needed for standby losses. An automatic disconnect circuit that disconnects the PV system from the grid when the PV system is down and reconnects when the PV system is operational should be implemented. Disconnect controls should be added to these systems to avoid the large losses when the PV system is down, or an inverter system that does not have high parasitic loads should be used.

3.4.2 Consider an automatic monitoring system for PV system operation

Occupants and operators were often unaware of extended down times, which limits useful output. There is no way to know whether a grid-tied PV system is operating correctly without manually checking the inverter output on its display terminal or unless someone downloads and examines the power data from the detailed monitoring system. Continual manual monitoring is not practical, so a simple automated system should be put in place that alerts the building operators when the system is down. A simple method or monitoring technique that provides feedback to the owners and occupants about PV generation effectiveness or performance ratio would address the simple problem of inverter faults that require manual restarts. This fault, typically caused by system integration issues, has been a primary source of PV system downtime in the case studies.

For example, the BigHorn PV system was estimated to be fully functional for only about one-third of the days during the two-year monitoring period and operated with only one of the three inverters for half the time. During periods of high output by the PV panels, the DC current exceeds the breaker limit (60 A) and trips the inverters offline. An additional intermittent problem, which became worse after the arrays were rewired, is that the battery circuitry occasionally fails to provide the proper power to the inverters when they are not producing power. This causes them to lose their memory and shut down. Because of the overcurrent and the battery circuit problems, one or both inverters shut down frequently. Because there is no automated means of alerting the building operators when an inverter has failed, they must be

manually checked. Relying on manual checking and resetting the inverters has led to long periods when the system is not fully operational.

3.4.3 *Locate PV panels where they will not be shaded*

Each PV array experienced shading that resulted in energy penalties of 2% to 44% output reduction. Sources of shade included trees, canyon walls, snow, and the building structure. PV panels should be located where they will not be shaded. The annual performance of the Zion PV system is degraded by 7% because a tree partially shades the west set of modules late in the afternoon (see Figure 3-36). CBF's PV array is shaded by the building's exterior structure (see Figure 3-37). The building shading accounts for all known system degradations, reducing output by 44%. Peak summer output of the CBF array has been reduced by shading to the point that the system provides more energy in the winter and swing seasons than the summer.



Figure 3-36 Tree shading of Zion PV array



Figure 3-37 PV array and shading caused by CBF building structure

Snow reduced the overall annual PV production by about 1.2% at Oberlin. Figure 3-38 is a photograph of accumulated snow on the flat sections of the Oberlin PV array, which typically have more snow accumulation than the tilted sections. Although not quantified, snow also shaded BigHorn's and Cambria's PV systems. The BigHorn PV system consists of amorphous silicon panels that are laminated onto the conventional standing-seam metal roofing. Some of the BigHorn PV panels showed signs of deteriorating after three years. The plastic laminate separated from the PV material in small areas spread over the PV panels. This problem occurred only on the 120-W panels in the area that has the most snow and ice coverage.



Figure 3-38 Oberlin PV array partially covered with snow

3.4.4 Consider specifications for how a PV-based UPS system transitions to and from utility power

The Zion PV system is a high-value feature even though it displaces only a small part of the total energy load. During daylight hours, the system can provide power for business operations without relying on power stored in the UPS system battery bank. This system handled 40 power outages that ranged from 1 second to 8 hours during the monitoring period. From February 2001 through May 2002, the building power was monitored to verify the operation of the UPS system. Because of the unreliable power in the area, the power shut off many times. A couple of times, the UPS system could not maintain clean power. If the grid shut down for less than 0.5 seconds, the scan rate on the EMS did not record the power failure. We believe that the panel had many split-second disturbances that the EMS could not record. The total time the grid was unavailable and the UPS system was functional during the evaluation period was 107.4 hours or 2.6% of the time. The UPS maintained power to the building and the EMS during all but two of these instances. For example, in one case the power turned on and off 40 times in less than 5 seconds before disconnecting. The main UPS system has thus had difficulties determining when to disconnect from and reconnect to the utility power. The reliability of the PV system has been excellent, but its use as a UPS has not been satisfactory. As a result, some smaller, self-contained UPS systems were installed on critical devices, creating additional parasitic loads. Future efforts to use PV systems for building-wide UPS systems should carefully investigate how the equipment responds to the types of power failures the building is likely to experience.

3.4.5 Use maximum power-point tracking controllers

A performance-limiting feature of the Zion PV system is the fixed-array voltage control required for UPS battery charging. The PV array operating voltage is set at 53.6 VDC, as this is the float-voltage set point of the inverters. The maximum power point (MPP) of the array is often greater than the fixed-voltage set point. An MPPT voltage controller would increase performance of the Zion PV system by 16% as compared to the fixed operating voltage control of 53.6 VDC. For summer weather conditions of 104°F (40°C) and a wind speed of 3.28 ft/s (1 m/s), the MPP is 54 VDC to 59 VDC, depending on solar insolation and cell temperature. For winter weather conditions of 32°F (0°C) and a wind speed of 9.8 ft/s (3 m/s), the MPP is 69 VDC to 73 VDC, depending on insolation and cell temperature.

The BigHorn inverters also do not have MPPT ability. The inverters were not designed to operate in a grid-tied system; therefore, circuitry was included to couple the inverters to the grid. This circuitry includes four 12-V batteries used to maintain the inverter memories at night. The battery backup system is tied to the Phase-A inverter to maintain the battery charge. Charging the external battery backup requires the Phase-A inverter float voltage to be set at 50 VDC. The Phase-B and Phase-C inverters were also set at 50 VDC to match the Phase-A setting. Cell temperature affects the output of the amorphous-silicon PV modules only slightly; however, the peak power-point voltage drops as the cell temperature rises. Because the modules are integrated into the insulated roof of the BigHorn Center, there is little heat loss through the backs of the modules and cell temperatures can exceed 170°F (77°C). The annual average AC Generation Effectiveness values were 3.3% for the BigHorn PV system without inverter faults and 3.9% for the same PV array and an MPPT inverter, which is a 20% annual improvement with the MPPT inverters over the use of fixed voltage inverters.

3.4.6 Grid-connected PV systems and inverters should be carefully designed as an integrated system

Numerous problems with the original BigHorn PV system design have limited its useful output. We have recommended that the PV system inverters be replaced with ones that are designed to be grid-tied to significantly improve system reliability and performance. The Cambria inverter was replaced because of frequent faults that significantly reduced overall output. The new inverter has minimized downtime and increased system output.

The Oberlin balance of system components have had limited operational issues. A performance degradation issue arose because the inverters shut down near peak operating limits, as illustrated in Figure 3-39. Occasionally, when the inverters operated at the maximum power output of 15 kW AC, they automatically tripped off, and then restarted after five minutes. To identify this inverter fault, minute data collected on PV system performance were considered. Because the automatic restart after an inverter fault of this type was 5 minutes, an identifiable pattern in PV production displayed by the minute was evident. Figure 3-39 shows a day when this occurred multiple times with all three inverters. Displaying the AC PV production in hourly averages does not identify this inverter fault pattern. To fix this problem, the inverter maximum allowable utility voltage output set point was increased, as the error code from the inverter indicated a high AC line voltage fault.

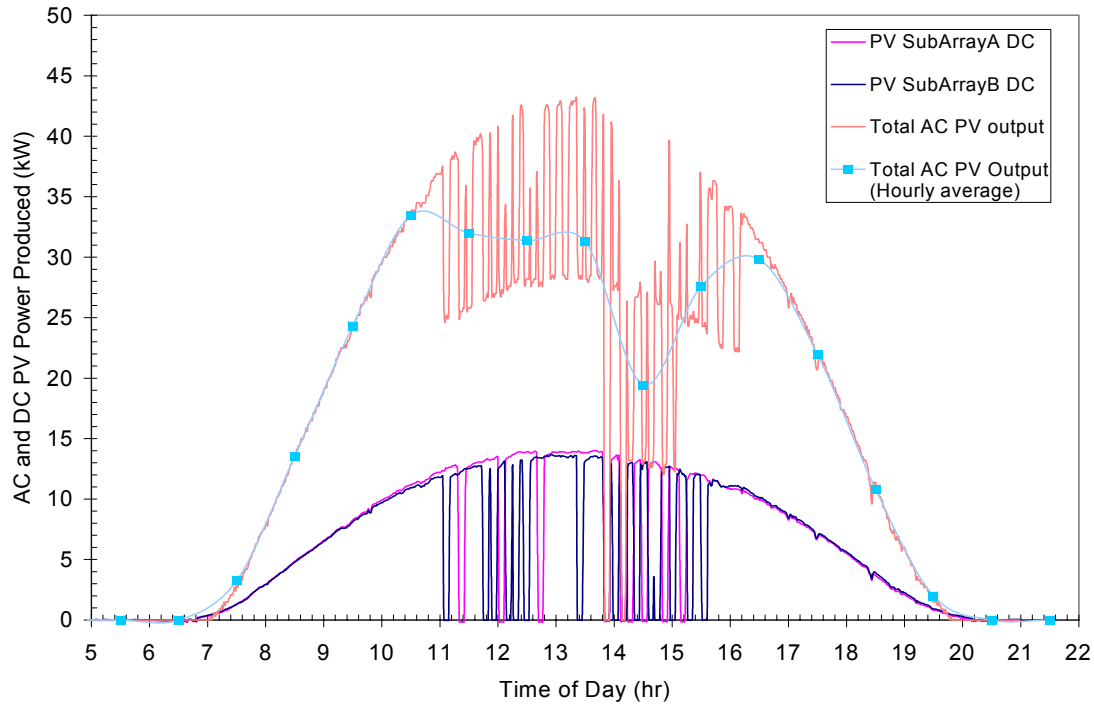

Figure 3-39 Oberlin inverter shutdown example with minute and hourly PV performance

Other Oberlin PV system component faults included occasional AC PV circuit breaker trips and additional unidentified inverter faults. A single case of circuit breaker faults was documented. The cause of the breaker faults probably involved a high inrush current required to energize the isolation transformers during a loss of grid power to the PV system. We calculated that 707.9 kWh, or 1.2% of the annual PV production, was lost because of PV system downtime related to system component faults. This time was minimized because continuous monitoring detected trips and inverters were quickly reset by attentive occupants. Without monitoring, these downtimes may have been much longer.

3.4.7 Integrate PV systems with demand-responsive controls and on-site thermal storage to maximize energy cost savings and payback

The economic payback of PV systems depends on the net metering and interaction with demand charges. PV systems reduce building peak electrical demands very little. One of the largest variable electric loads in these daylight building is the lights, which are needed most when the sun is down. The peak summer building electric load is typically in the late afternoon to early evening; the PV peak output is in the middle of the day. This means that the PV system output does not correspond well with the building load profile. Therefore, the payback for the PV system is poor because it offsets only electricity energy charges, which are typically only \$0.02–\$0.05/kWh. See Section 3.5 for further discussion of peak demand profiles.

As PV typically does not significantly reduce peak demand charges, alternative methods for reducing peak demands in future ZEBs that have large PV systems will have to be considered. The Oberlin PV production does reduce energy consumption charges; however, the electricity demand costs in this all-electric building are not typically reduced. Cost justifying the PV system solely on energy cost reductions is difficult. There is a great potential for reducing peak demands and demand charges with the PV system in the case of the Oberlin’s 60-kW PV system. Reducing peak demands with Oberlin’s PV system would require demand responsive controls that limit electrical loads during periods of minimal PV production

(during cloudy periods or at night). Additional demand reduction cost savings that result from the PV system would increase the cost-justification of the PV system.

In future ZEBs, energy use will decrease and site energy production will increase, which will result in significantly lower net site energy use. In contrast, peak electrical demands are not reduced at the same rate as the net site energy use, as PV does not offset peak demand as it does with energy use. The building's peak electrical demand and associated charges will become even larger components of the overall energy costs. Therefore, technologies to reduce peak demands in future ZEBs, such as demand-responsive controls and ice storage systems, will become more important in realizing energy costs savings that are comparable to energy savings.

The net metering rate structures will become even more important in future ZEBs, as the size of PV systems on buildings increases and energy use decreases. For net metering agreements that credit only exported PV energy at the same rate (or less) than the utility charges per kilowatt-hour, the full value of the PV energy is not realized. On-site storage systems such as ice storage combined with demand-responsive EMS will be required to realize the full economic value of the energy and power produced by the PV systems. With on-site storage, a significant PV system, and demand-responsive controls, future ZEBs will be able to use the full potential of PV systems to reduce demand charges and energy charges. In terms of a ZEB goal, on-site storage may be in conflict with this vision, as the primary purpose of storage is to reduce peak demands and energy costs, not energy use. Without net metering utility rates that do not account for the full value of on-site generation, using some amount of the PV energy to reduce demand first, and then supplying excess PV to the grid, is more cost effective. The balance of when to use PV for storage for reducing demand and when to supply excess PV to the grid to offset energy use to reach the ZEB goals should be investigated further.

3.5 Peak Demand and Demand Management

The easiest method to reduce energy cost in a commercial building is to reduce the peak demand charges. As seen in Figure 3-40, the Oberlin demand charges contribute more than 50% of the total costs. The BigHorn electrical demand charges and associated taxes constitute a significant part (59–80%) of the monthly electricity bills. An efficient building that uses very little energy could still have large demand charges. The peak demands and demand savings for each building are shown for heating and cooling seasons in Table 3-11. Evaporative cooling, reduced LPD, and HVAC equipment downsized to meet reduced thermal loads are the best ways to guarantee peak demand reductions. All these techniques reduce peak demands because even if they are all being used, the peak consumption is still less than the baseline equivalent. Technologies such as daylighting, Trombe walls, PV systems, and natural ventilation that depend on the solar resource are not always available to reduce energy use. Therefore, they cannot be relied on for peak demand reduction unless advanced controls are used to dynamically adjust building energy use to account for the variability of the solar resource.

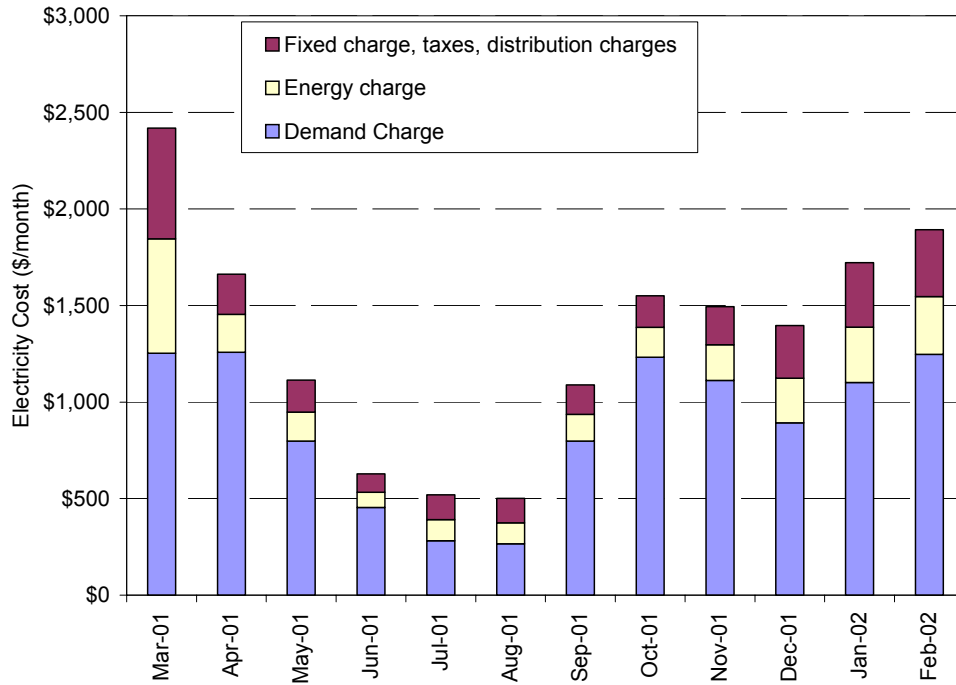

Figure 3-40 Oberlin monthly energy cost by charge type, March 2001–February 2002

The greatest demand savings were at Zion—a primary reason for the largest energy cost savings. CBF had the lowest energy cost savings because it had higher demand charges than the baseline. CBF used heat pumps with propane backup; the baseline used a propane heating system as the primary heating source. Oberlin also had high heating demand charges because it occasionally used backup electric boilers that limited energy cost savings. When the electric boiler operated at 112 kW for 15 min, the demand charges of \$8.59/kW resulted in high utility bills. The monthly demand charge for operating this unit for 15 minutes was \$962.

Table 3-11 Peak Demand Performance Summary

Demand Metrics	All-Electric Buildings						Electric and Gas Buildings					
	Oberlin		Zion		Cambria		CBF		BigHorn		TTF	
	winter peak	summer peak	winter peak	summer peak	winter peak	summer peak	winter peak	summer peak	winter peak	summer peak	winter peak	summer peak
Baseline Seasonal Peak Demand (Peak kW and W/ft ²)	136 kW	56 kW	108 kW	89 kW	249 kW	90 kW	64 kW	57 kW	131 kW	124 kW	24 kW	40 kW
	10.0 W/ft ²	4.1 W/ft ²	9.3 W/ft ²	7.7 W/ft ²	7.2 W/ft ²	2.6 W/ft ²	2.1 W/ft ²	1.8 W/ft ²	3.1 W/ft ²	2.9 W/ft ²	2.4 W/ft ²	4.0 W/ft ²
As-Built Peak Demand (Peak kW and W/ft ²)	142 kW	20 kW	28 kW	15 kW	99 kW	84 kW	136 kW	132 kW	68 kW	49 kW	17 kW	20 kW
	10.4 W/ft ²	1.4 W/ft ²	2.4 W/ft ²	1.3 W/ft ²	2.9 W/ft ²	2.4 W/ft ²	4.4 W/ft ²	4.3 W/ft ²	2.2 W/ft ²	1.2 W/ft ²	1.7 W/ft ²	2.0 W/ft ²
Annual Energy Cost Savings	35%		65%		43%		12%		53%		51%	
Time of As-Built Peak Demand	1/4 9:00 am	8/9 4:00 pm	12/24 9:00 am	8/4 8:00 am	N.A.	N.A.	2/5 9:00 am	6/24 11:30 am	12/20 6:00 pm	7/11 9:00 pm	1/20 9:00 am	9/9 6:00 pm
Peak Demand Savings Including PV (kW savings and percent savings)	-6 kW	36 kW	80 kW	74 kW	150 kW	6 kW	-72 kW	-75 kW	63 kW	75 kW	7 kW	20 kW
	-5%	65%	74%	83%	60%	6%	-113%	-132%	48%	60%	30%	49%
Load Factor (average monthly demand/peak 15-minute demand)	0.09	0.06	0.40	0.53	0.45	0.42	0.26	0.34	0.35	0.35	0.32	0.28
Peak Demand Savings due to PV	0.0 kW	10.0 kW	NA	NA	NA	NA	0.8 kW	0.9 kW	0.0 kW	0.0 kW	NA	NA
PV Demand Savings Performance Ratio (PV Demand Savings/AC PV capacity)	0.00	0.22	NA	NA	NA	NA	0.24	0.27	0.00	0.00	NA	NA

1. For Zion peak demands, PV does not directly reduce demand. However, demand-responsive controls used PV production and building thermal mass to offset demand.
2. For CBF, baseline peak demands are lower than as-built because of the baseline propane heating system; the actual system was primarily heat pumps with propane backup.

3.5.1 Low-energy buildings peak demand profiles

Peak demands in low-energy buildings often occur at atypical times of the day. The conventional commercial building has summer peak demands in the late afternoon when cooling and lighting loads are the greatest. Well-daylit buildings reduce lighting and peak cooling loads by shifting peaks to atypical times of day. The TTF annual peak was shifted from the peak cooling day to a swing season day. The annual TTF peak occurred late in the day when some cooling was required combined the full lighting load, which occurred during a period of minimal daylighting. When energy efficiency technologies are combined with large PV systems, as at Oberlin, the demand profiles are almost opposite the energy use patterns in typical buildings. During the summer months, large PV systems in commercial buildings can export electricity from 8:00 a.m. to 6:00 p.m., as shown in Figure 3-41. From the utility perspective, the building was a net positive during daylight hours in the summer and provided power when it was most needed by the grid. Low-energy buildings can shift when a peak demand is met, but may not necessarily reduce the overall peak demand.

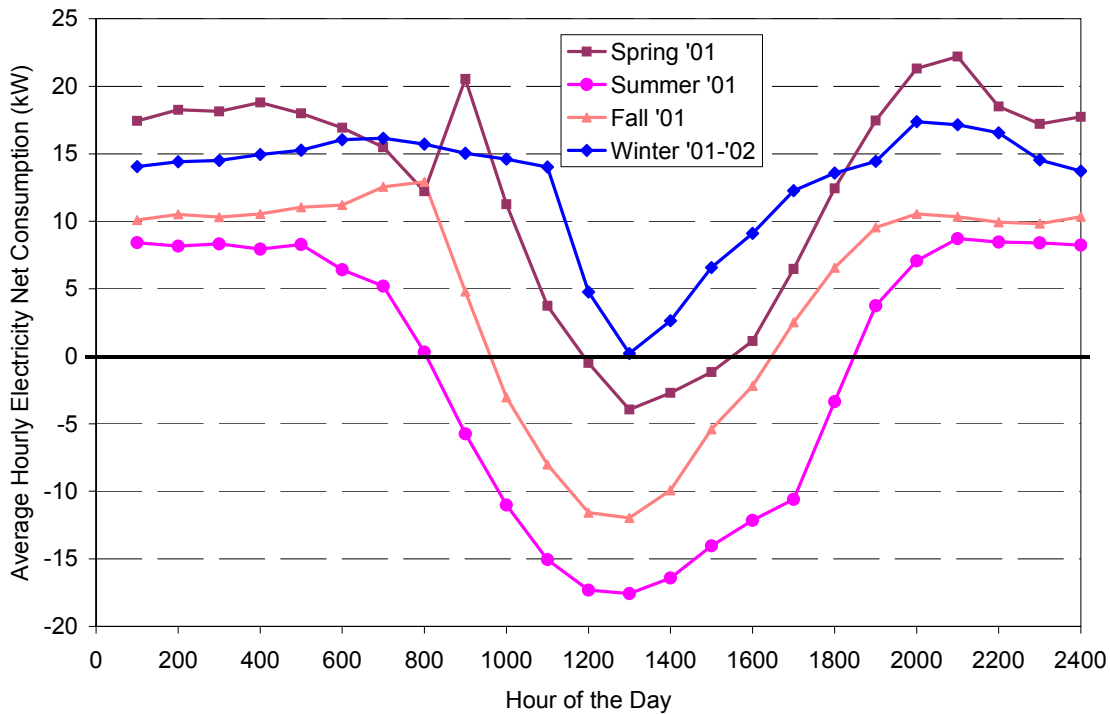

Figure 3-41 Daily average net electricity consumption load shape by season, with PV production

An examination of the peak demand days at BigHorn revealed that the peak demand typically occurs during one of four scenarios:

- During normal business hours in the winter after the sun sets and most of the interior and some exterior lights automatically come on
- During normal business hours when dark clouds cover the sun and more interior lights come on
- After store hours when the cleaning crew turns on most of the interior and exterior lights

- If the electric forklift is plugged in for charging when the power draw is already high, which sometimes occurs at the same time as one of the first two scenarios.

In the first two scenarios, little can be done to reduce the demand because the lights are required for normal business operation. Fortunately, these have the smallest peak demand. The third scenario is preventable with some training of the cleaning crew to avoid turning on all the lights at the same time; however, this requires retraining with each new crew. The fourth scenario is preventable by charging the forklift at night. However, this would require a timer on the charging station circuit or someone to come in late at night after the exterior lights are turned off. Each of the scenarios could also be addressed by using the energy management system to manage loads, such as the forklift and pumps.

The electrical power profiles for typical peak demand days at BigHorn during the summer are shown in Figure 3-42. The heavy black line is the purchased electrical power. When this line is below the top of the graph, the PV system provided some of the building electrical load. In Figure 3-42, the PV system provides some power during the day; however, the PV system was operating on only one of three inverters on this day, and did not offset the demand when a peak was met.

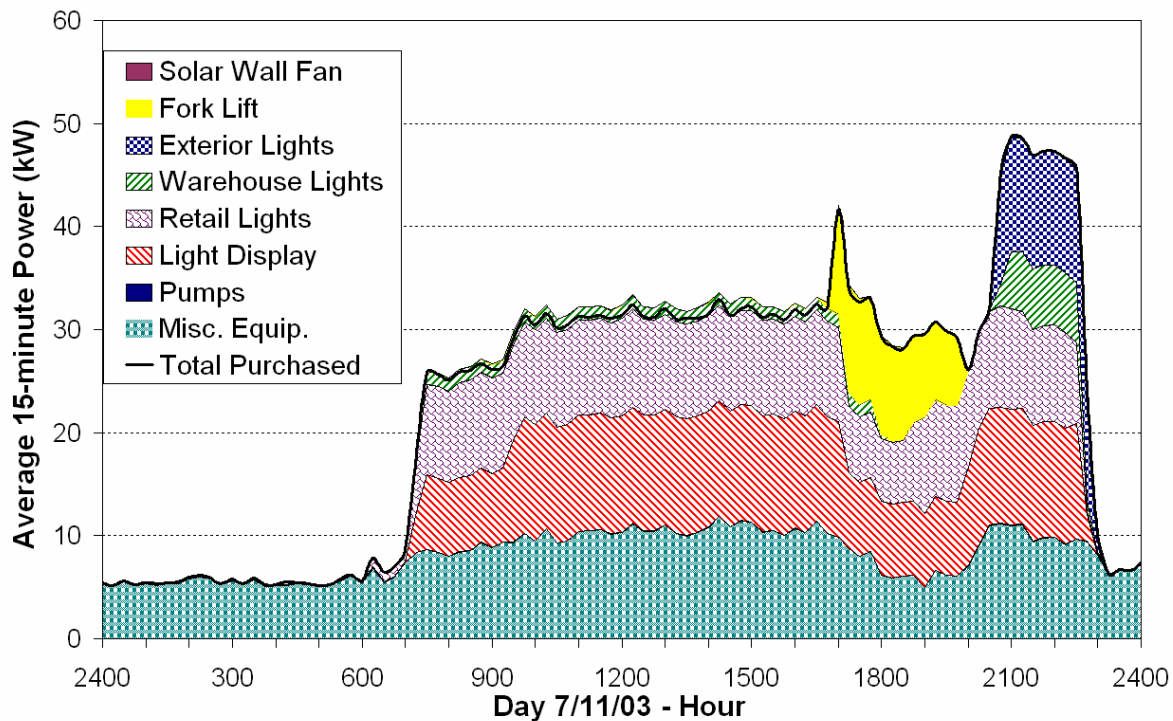

Figure 3-42 Electrical power profile on the peak demand day in July 2003

The peak demand in Figure 3-42 occurred after the store was closed when the cleaning crew came in and turned on most of the lights, including the entire lighting display. Earlier in the day, the forklift was plugged in for charging right before closing time, which raised the power draw by nearly 10 kW but still allowed it to remain below peak.

3.5.2 PV systems have had limited success reducing peak demands

The PV systems in this set of low-energy buildings have not significantly reduced building demands. In these buildings, any small demand reduction from PV is from load diversity, as shown in Table 3-11. Figure 3-43 demonstrates that the Oberlin PV system did not significantly reduce peak electrical demand.

For July and August, the peak demand would have been 10 kW greater without a 60-kW PV system. The peak demand for these months was reduced because the peak consumption was coincident with PV production. For the other months of the year, the peak demand occurred when no PV production was present. Similar peak demand trends were documented for all the other PV systems in the case studies (see PV Demand Savings Performance Ratio in Table 3-11). Peak demands often occurred during atypical times that did not coincide with PV production, when daylighting was not available for demand reduction.

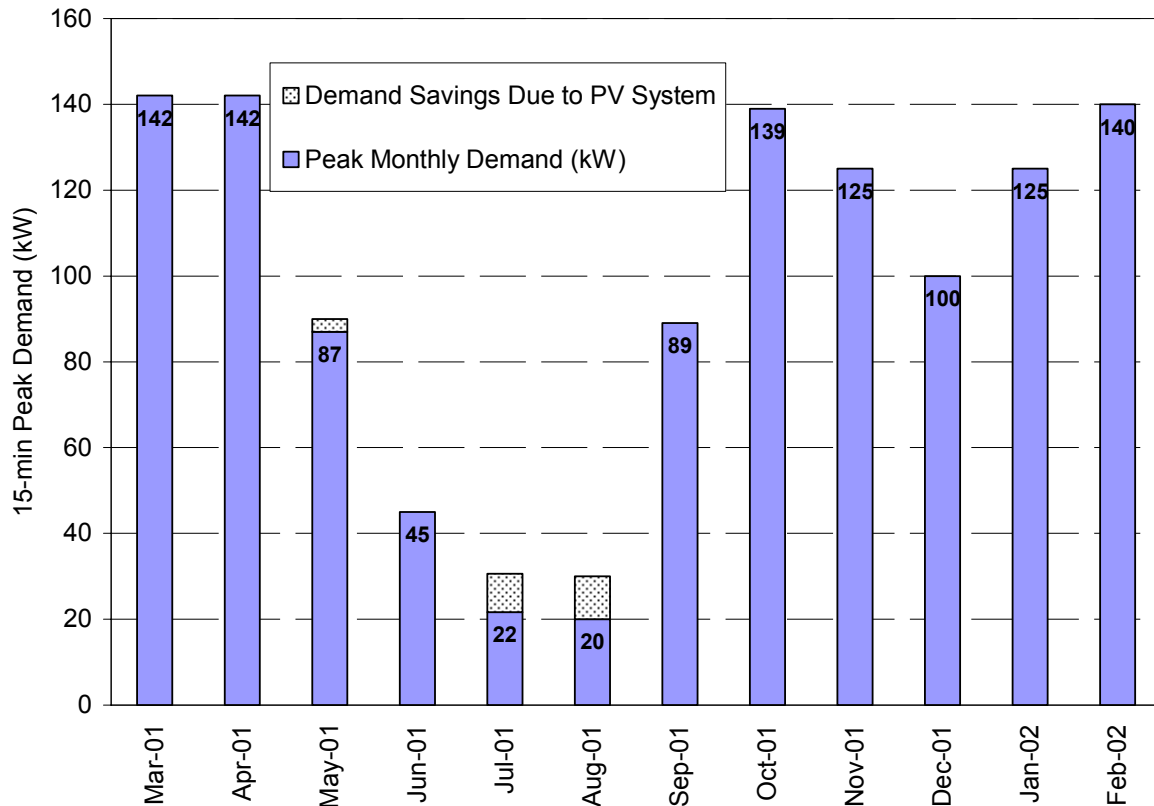

Figure 3-43 Oberlin peak 15-minute demand by month (includes PV production)

3.5.3 Demand-responsive controls can save energy costs and increase load factors

The largest energy cost savings of all the buildings was at Zion because of its aggressive demand management, which the other buildings did not use. The load factor was also consistently higher than the other buildings. Demand management combined with on-site storage (building mass) was the best use of on-site generation for reducing peak demands. Oberlin was the least successful at using PV for demand reduction, because of its high peak demands and large PV system that reduced energy use, but not at times of peak demand. This combination resulted in low load factors.

At Zion, we analyzed all the building loads and determined typical use trends to minimize the demand costs. Once the end uses that typically contributed to peak demands were identified, we determined which loads might be shifted until a peak had passed.

The cost associated with demand can be found by multiplying the maximum power draw over a 15-minute window by the \$8.10/kW demand charge. The typical peak demand during the winter can exceed 44 kW, when all end uses, including the hot water, lighting, and some heating, were on at the same time. Although the key contributor to the increase in peak demand was turning on lights in the morning, the

heat was also on, partly because of the recovery from night setback. The hot water, lighting, and heating were at a maximum for the day during the demand peak. These types of loads offer the most potential for limiting the peak demand because they are not considered essential for short-term operation of the building. Hot water and heating systems can be temporarily turned off during potential periods of peak demand. During periods of low demand, the hot water and heating systems are turned on. The nighttime heating is used only if the building can be returned to a comfortable temperature without incurring a demand charge. This type of control strategy can also take advantage of on-site generation for potential demand reduction by offsetting the utility power draw with on-site generation. Demand is limited by continuously adjusting the heating set point of the Visitor Center based on the measured building demand. The EMS can reduce the temperature set point by 0.2°F (0.11°C) every 20 seconds when the demand is near the monthly peak demand. The maximum set point reduction is 10°F (12°C).

The domestic hot water (DHW) units in the Zion Visitor Center and Comfort Station have demand-responsive controls. The DHW is disabled if the instantaneous building demand exceeds the weekly 10-minute peak demand. These units remain off for at least 8 minutes in an attempt to shift the load. If the building demand is less than the weekly peak demand, the DHW units are enabled. The DHW is mainly used for cleaning, usually early in the morning. The hot water is not considered essential to the normal operation of the building. Before demand-responsive controls were installed, the cleaning crew emptied the water heater for cleaning, which caused a spike early in the morning when the system tried to recover just as other loads peaked. The strategy shifts the hot water recovery to a more advantageous time based on demand and rate structure.

Figure 3-44 shows the energy consumption of a heating day after demand-responsive controls were implemented. Most noteworthy is that when the lights came on in the morning, the heating was reduced to maintain a flat profile. Heating consumption was decreased by 6 kW until daylighting reduced the electrical lighting loads and the PV system provided sufficient energy to limit demand. The heating energy consumption over the day is similar to that of a building without demand limiting because the load was shifted to a period when the heating system would not incur a peak demand. This load shifting strategy is an effective application of demand-responsive controls because the building still used the same energy but over a longer period; the controls were effective because the peak was reduced significantly. In addition, the DHW load, which can peak at 3.3 kW in the morning, was also shifted to later in the day. The building may be underheated when the demand-responsive controls reduce the heating set point. Zone temperature fluctuations were reduced during the load-shedding period by not setting back the nighttime set point, which allows for increased heat storage in the building thermal capacitance during periods of low demand. Again, the equipment and lighting loads could not be shifted or limited because they are necessary for building operation.

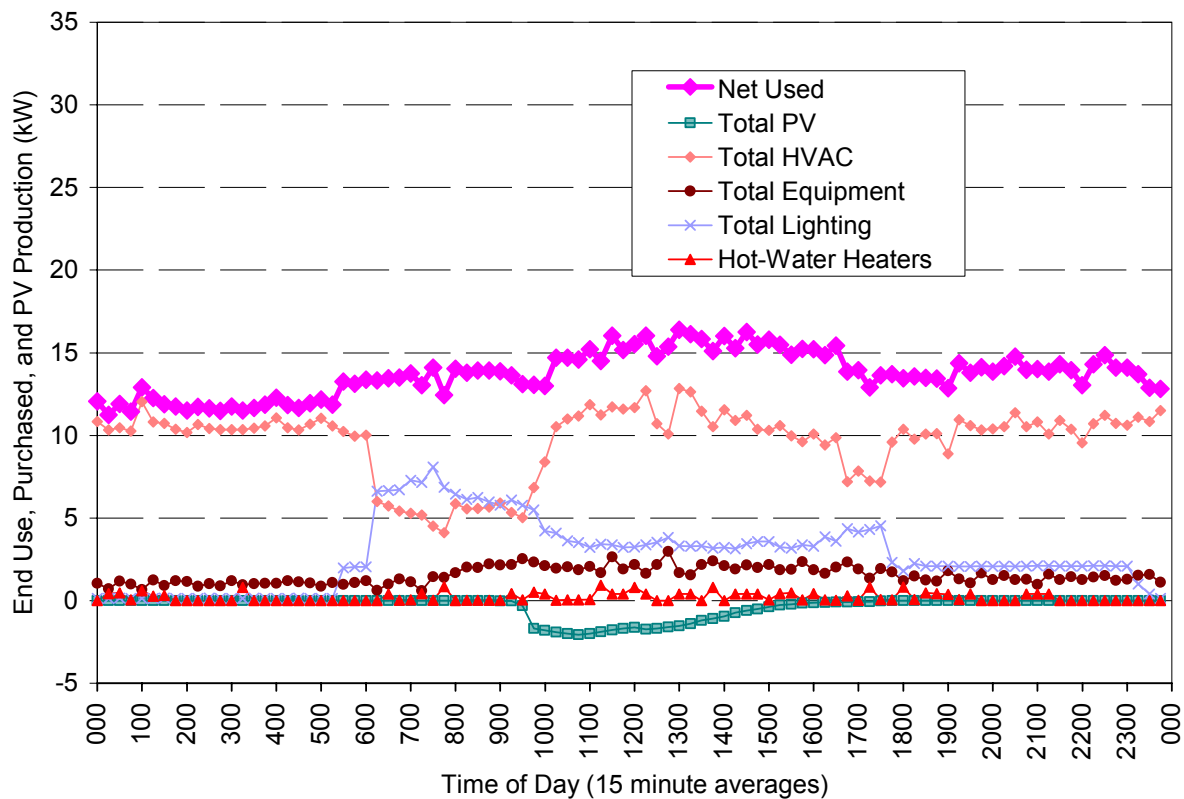

Figure 3-44 Zion demand-responsive controls example

In general, by identifying short-term, nonessential end uses that contribute to peak demand charges, we developed a control strategy to shift these loads to significantly reduce demand charges. After overcoming some initial control implementation problems, we have been able to keep the peak demand at less than 30 kW for the entire year. Peak demands for previous heating seasons without demand-responsive controls exceeded 44 kW. Understanding the optimal demand controls involves understanding the interaction of on-site generation, daylighting, and precooling and preheating techniques to charge the thermal mass of the building during off-peak hours.

When backup electric resistance heating is used in heat pumps, as reserve capacity for ground loops, or in radiant panels, these systems must be carefully staged and controlled to realize peak demand savings. If these systems can be used as part of a demand-responsive control system so they are not responsible for a building setting a peak demand, they can be successfully used as backup heating systems. The annual peak demand at Oberlin occurred during a high heating load day when the 112-kW electric boiler operated during the morning warmup period, as shown in Figure 3-45. PV production did not offset this peak demand at 9:00 a.m. Significant cost savings could be realized by sequencing the heating equipment to meet the heating loads and operate within demand-responsive constraints. This may use slightly more energy, but significantly even out the loads. The building could be preheated when PV demand is available maximizing the benefit of this system. Similar benefits could be achieved during the summer by precooling the building when extra on-site generation is available.

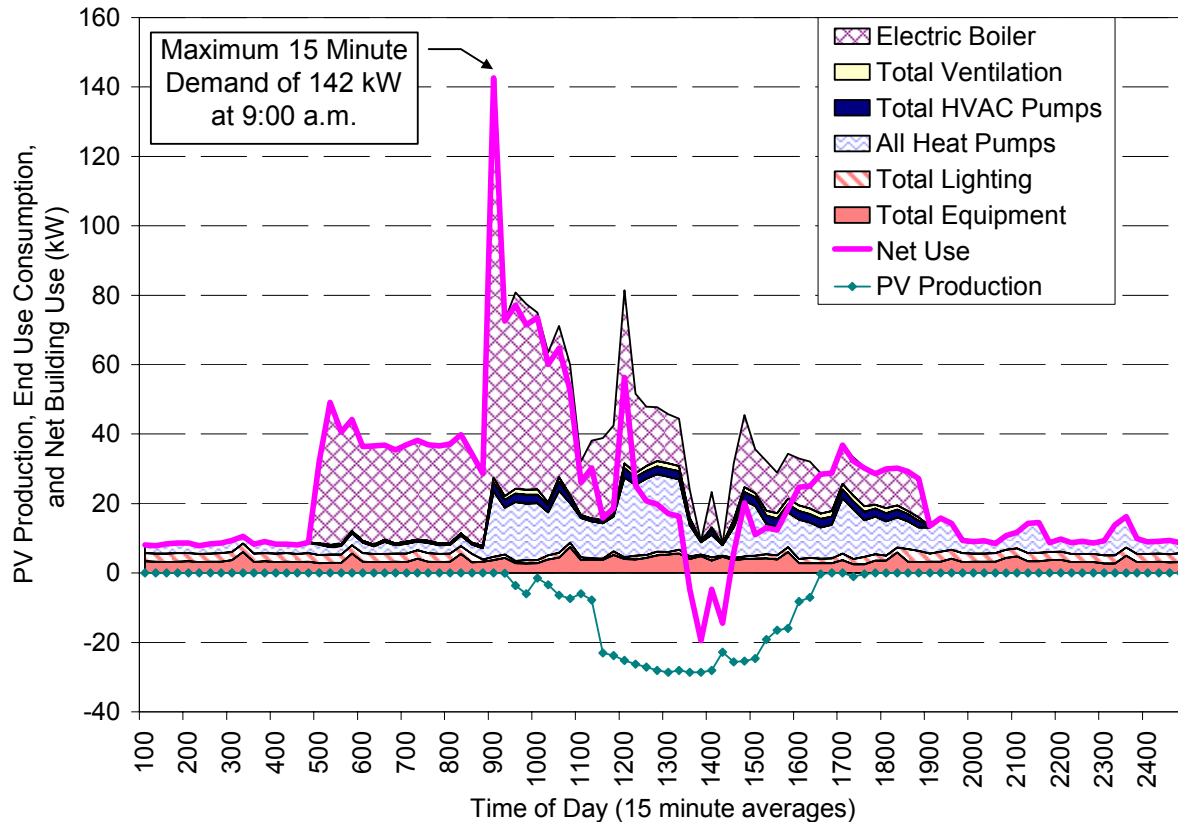

Figure 3-45 Oberlin peak heating season utility demand, PV production, and end use

3.5.4 Low-energy buildings can have low load factors

Building energy managers use peak electrical demand and load factor performance metrics to determine how well they balance the building energy use with peak demands; utilities use these to determine how much extra capacity they need to meet all the electrical loads of buildings. The peak electrical demand is typically defined as the highest average power over any 15-minute window in a month. The load factor is a dimensionless number and is the ratio of the average electrical energy and the peak electrical demand. Buildings often have load factors around 0.5, which means that the peak demand is twice as high as the average power. Utilities charge for peak demand to support the extra capacity needed in the system. Demand charges can be more than half the electric utility bill; therefore, reducing peak demands is in the best interest of the building owner.

Energy-efficient buildings strive to lower energy consumption; however, they often do not reduce the demand by the same amount. If the energy use is reduced more than the peak demand, the load factor decreases. This means that the utilities will have to supply less energy, but there is no reduction in capacity requirements. Therefore, the utilities still have to maintain the same expensive generation, transmission, and distribution capacities. Keeping power plants in spinning reserve as they wait for higher demands requires energy, so even though a building may reduce site energy consumption, the source energy consumption may not be reduced by the same amount. Even buildings with on-site electricity generation from PV systems rarely reduce demand by more than a few percent. Energy-efficient buildings should manage peak demand with demand-responsive controls and possibly on-site energy storage.

Buildings that employ energy efficiency and PV systems to approach zero net energy can export electricity to the grid when the PV systems produce more than the buildings use. If a building exports

more energy than it uses over a month or a year, the load factor can be negative depending on how it is defined. A negative load factor has a very different meaning from a utility point of view. It tells the utility that the building exported electricity, but not the capacity needed to meet the building loads.

The building closest to a ZEB (Oberlin) also has the worst load factor of all the buildings, with a load factor less than 0.1. The load factor, or the proportion of energy use to peak demands, is extremely unbalanced when PV systems offset significant energy use, but do not offset peak demands. For widespread adoption of future ZEBs, these buildings will need demand management controls integrated with on-site storage. This will ensure proportional energy and demand savings. Future ZEBs may shift peak demands and reduce absolute peak demands with efficiency technologies, but there will be significant unrealized utility impact reduction if the on-site generation technologies are not used to further help reduce a building's impact on the grid. In addition, relying on the grid to provide annual storage for net meter accounting in a widespread ZEB adoption scenario may not be sufficient. Future work in this area is required to understand the utility infrastructure needed to allow for widespread adoption of net-metered buildings. Integrated storage at the building or grid level may be needed to allow a large number of net-metered buildings to be connected to the utility grid.

Future work should focus on increasing load factors of ZEBs with significant PV systems. In addition, an effective load factor needs to be used in ZEBs that are net producers for any given month. Standard methods for calculating load factor when the average monthly energy use is negative do not provide useful results for understanding the demand-to-use ratio. Therefore, the effective load factor should consider either the building with no on-site generation or, alternatively, the ratio of energy supplied to the building to the actual peak demand.

3.6 Plug and Equipment Loads

Energy used in commercial buildings is very diffuse, with many types of end uses other than HVAC&L loads. In office buildings, energy used for office equipment is 16% of the total energy use, water heating uses 9%. Plug and equipment loads continue to grow in absolute energy use as they become a larger piece of the overall energy use pie as efficient HVAC&L systems become more prevalent. Thus, lessons learned and recommendations for future research concerning efficient plug and equipment load design and controls are becoming more valuable to the industry and to future ZEB designs.

The plug and equipment loads in the case studies included non-HVAC&L loads such as computers, monitors, printers, task lights, server equipment, other office equipment, elevators, DHW, emergency equipment such as egress lighting, PV system standby loads, laboratory process loads, display lighting, forklift charging, refrigerators, vending machines, and miscellaneous plug loads. Table 3-12 shows the equipment and plug load use percent of the total source use, use intensity, and ratio of average night to average day use for each building.

Table 3-12 Plug and Equipment Loads in High-Performance Buildings

Building	Equipment Use Percent of Total Source Use	Average Daily Peak and Nightly Minimum Equipment Use W/ft² (W/m²)	Average Night-to-Day Equipment Use Ratio	Issues
Oberlin	28%	0.32 night (3.4) 0.29 day (3.1)	1.1	High lab process loads, PV system night standby losses
Zion	33%	0.16 night (1.7) 0.37 day (4.0)	0.43	Demand-responsive controls limit when DHW can operate
Cambria	24%	0.26 night (2.8) 0.49 day (5.3)	0.5	High nighttime load caused by electronic equipment—computers, monitors, printers, and copiers—that is being left on Even in standby mode, the sum of all equipment still consumes a significant amount of energy
CBF	41%	0.34 night (3.7) 0.66 day (7.1)	0.52	High information technology equipment loads in the offices and server room that operate continuously
TTF	35%	0.25 (2.7)	N.A.	Equipment use based on simulation
BigHorn	39%	0.16 night (1.7) 0.50 day (5.4)	0.32	High lighting display loads during the day

3.6.1 Parasitic loads should be minimized

Parasitic loads are problematic in commercial buildings because they use energy even in standby mode. Even when a parasitic load is off, it still uses energy. The ratio of average night-to-day equipment and plug loads in Table 3-12 can indicate excessive consumption during unoccupied periods. The isolation transformers on PV systems at Oberlin and Cambria are prevalent parasitic loads. At Oberlin, the nightly PV system standby load results in more equipment and plug load energy use at night, which results in a night-to-day use ratio greater than 1.0 (see Figure 3-46).. See Section 3.4.1 for further PV system parasitic load analysis.

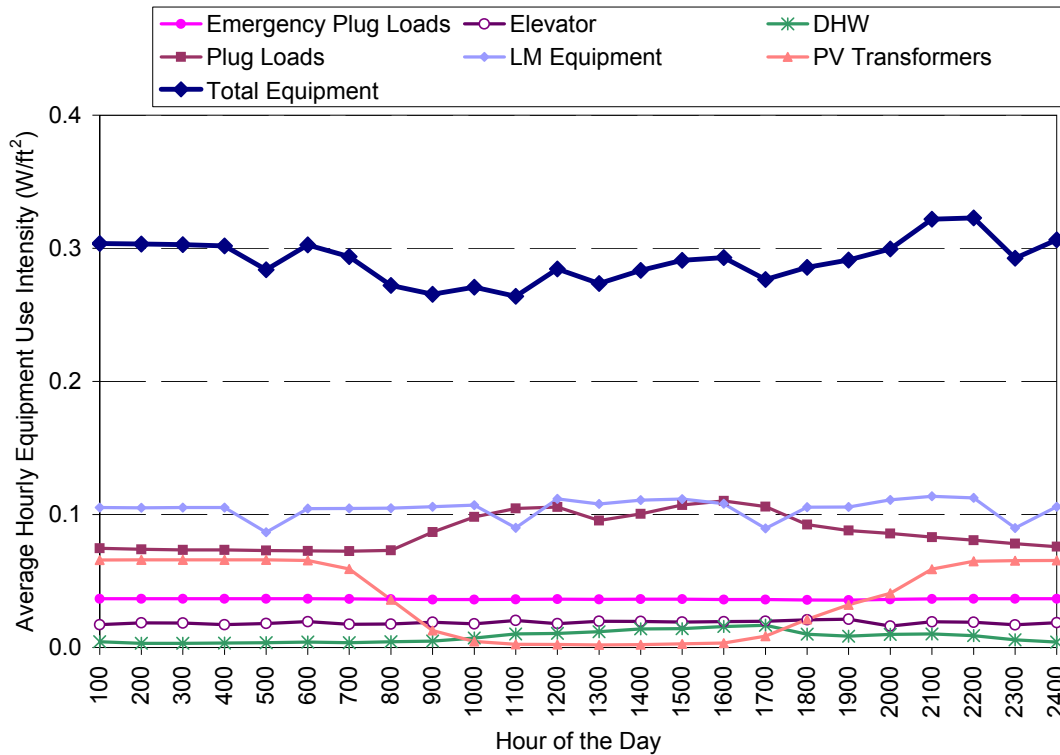

Figure 3-46 Oberlin equipment use intensity load shape

Equipment and plug loads at CBF include energy use for the elevator, the exterior and garage lighting, plug loads, and the mechanical room and storage room receptacles. Equipment and plug loads are the largest energy end-use category at CBF, followed closely by HVAC. Miscellaneous loads are significant and show seasonal dependence that indicates there could be heating loads associated with the elevator (oil heating) and the ground-floor receptacles. The results in Figure 3-47 show that CBF off-hour equipment loads are about half of what they are during the day, which indicates that equipment is being left on when not in use. Presumably, this is because a large amount of information technology equipment operates in the offices and server room. The off-hour plug loads in the Merrill Center are typical of contemporary offices, but they could be considered an opportunity for improving the energy performance of the building. Methods such as communicating with employees about the value of shutting down equipment, deploying new network-based software products that monitor and reduce computer power, and replacing equipment with energy-saving sleep mode, should be investigated to reduce off-hour plug loads.

Weekday daily load profiles at Cambria for the process and equipment loads are shown in Figure 3-48. The total load is very consistent and varies between 9 kW at night (normalized to 0.26 W/ft² [2.8 W/m²]) and on weekends to approximately 17 kW (0.49 W/ft² [5.3 W/m²]) during the occupied hours. The plug load profile closely reflects the occupant behavior. Most of the occupants arrive between 7:00 a.m. and 8:00 a.m. and leave between 3:00 p.m. and 4:00 p.m. The lunch break is consistently from about 11:30 a.m. until 1:00 p.m. The nighttime load is approximately half the daytime load, which is much higher than was anticipated during the design phase of the building. The high nighttime load is caused by electronic equipment including computers, monitors, printers, and copiers that are left on. Much of this equipment goes into a standby mode, which still consumes a significant amount of energy when all the equipment in the building is considered. The weekend/holiday plug daily load profile is flat and at the same level as the weekday nighttime load profile.

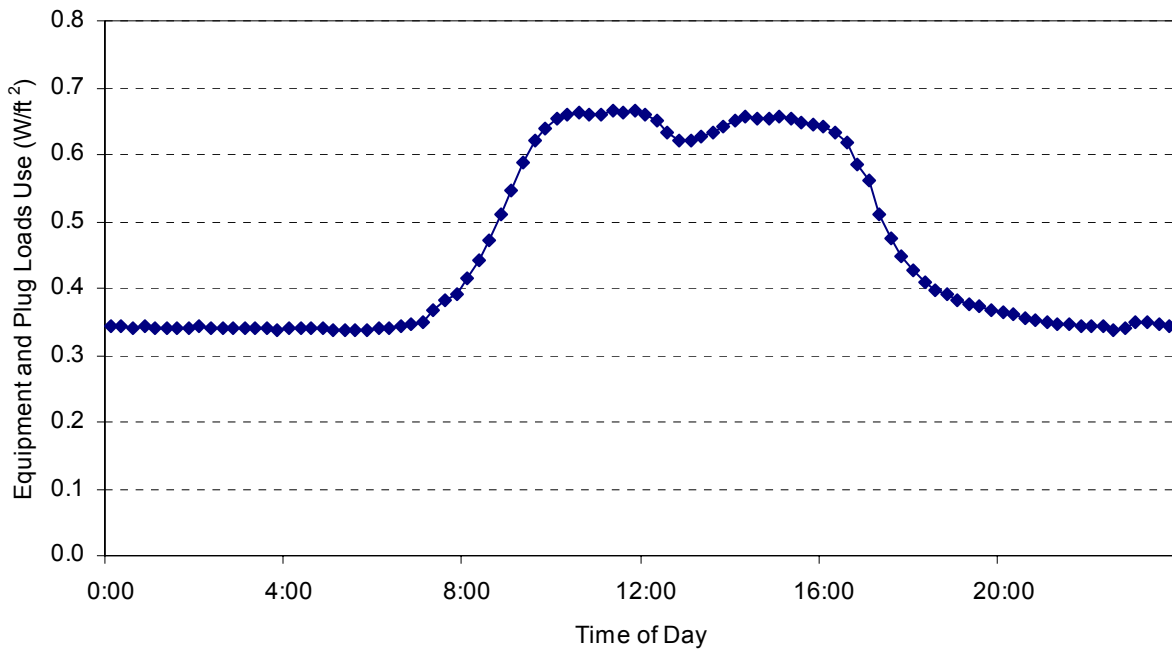

Figure 3-47 CBF average equipment and plug load use intensity

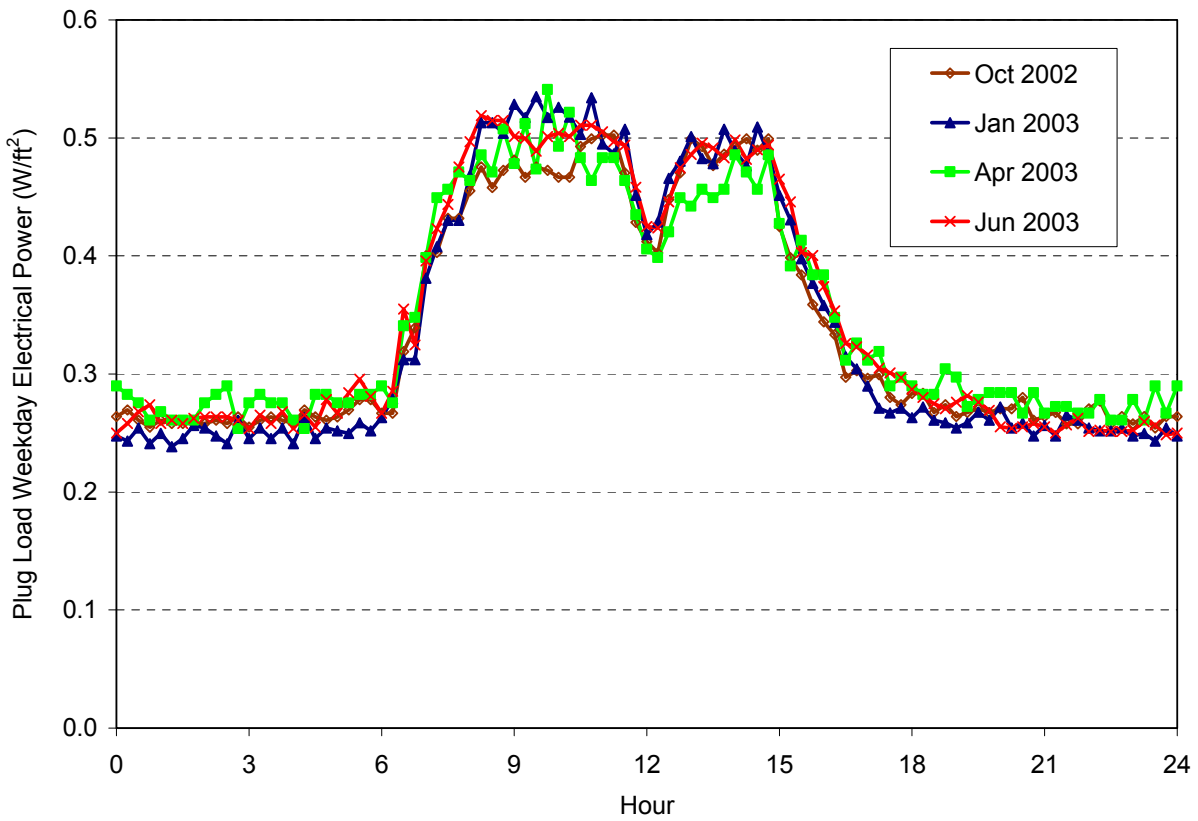

Figure 3-48 Cambria daily plug load profiles for weekdays

A significant part of the equipment and plug loads in all these buildings comprises idle computers. Energy savings can be realized by making the machines ENERGY STAR® enabled to shut them down during periods of inactivity. However, standby modes can consume a substantial amount of energy. The numbers and types of equipment left on or in standby mode were noted during an after hours survey. Most desktop computers were left on and were in standby mode. Their exact power draw is not known, but most desktop computers draw 40 to 80 W in normal operation. Most operating systems have a power management feature that will put the computer in standby mode after a certain period; however, these features reduce the power consumption by only about one-third when they are in operation. In addition, power management software could be installed on all computers. This type of program can be easily installed and controlled over a local area network. Annual energy savings are 100 to 300 kWh per computer.

Many CRT monitors in standby mode use 3 to 10 W; however, older monitors do not have a standby mode and use around 40 W when turned on with a blank screen. The computer and monitor energy consumption can be reduced with manual or automatic control. Manual control relies on users to turn off their computers and monitors at night. If this approach is not successful, power management software options can be implemented and controlled over a local network. Computer power management software can effectively reduce energy consumption during unoccupied periods. Energy savings average 200 kWh/yr per computer. Flat screen LCD monitors should also be used for added energy savings.

Computers are not the only large plug load; there are numerous printers at Cambria—nearly every occupant on the second floor has one. Each printer consumes energy even on standby. Replacing 80% of these printers with five central networked printers would save money in the purchasing, maintenance, and operation of the printers. One more opportunity to save energy is to power of vending machines. Savings can be substantial, but vary with the type of vending machine (Deru et al. 2003).

A major electrical end use at BigHorn is the lighting display area, which displays all the lighting fixtures and other interior decorating items. The displays are often changed to show new fixtures and new light bulbs. Even with efforts to control the energy consumption of this area with compact fluorescent lights (CFLs), the energy consumption is about the same as the lighting for the entire retail and office spaces. BigHorn has the lowest night-to-day ratio of equipment use, as display lighting is a large daytime use without a parasitic load, as these lights are turned off nightly. There are considerable plug and other electrical loads at BigHorn, including 37 computers; 22 CRT monitors; 8 LCD monitors; 7 printers; 17, 9-pin dot matrix printers; 2 copiers; 3 cash registers; accent lighting; 2, 10-gal domestic water heaters; 1, 500-W air conditioner in the server room; ceiling fans; 500 W of roof ice melt; 2 electric space heaters; 2 refrigerators; 3 vending machines; 2 microwave ovens; and other plug loads. These loads change continually as new equipment and plug-in lighting are added or removed. The accent lighting load comprises display lights and other plug-in lights that are used to accent products or features. Electric ice melt is required on some parts of the roof and roof drain structures to avoid ice damming, which can damage the roof and prevent proper drainage. At the beginning of the monitoring period, there was 500 W of roof ice melt; however, this number increased to approximately 6 kW because of persistent ice damming problems. Designing roofs to minimize ice dams is typically a better solution than melting the ice with electric resistance heaters.

Equipment and plug loads continue to grow in absolute energy use as well becoming a greater piece of the overall building energy use pie as efficient HVAC&L systems become more prevalent. Parasitic loads that use energy during standby or off modes are of particular concern, as they have been problematic in each of the case studies. Even in standby mode, equipment can consume a substantial amount of energy. Future work is needed in this area to understand the energy penalty of each plug load that includes an AC-to-DC conversion device and investigate potential solutions for limiting energy use when equipment is not needed. Potential energy-saving technologies, such as switching transformers or a DC plug load electrical infrastructure that leverages on-site DC generation, should be investigated.

3.6.2 Domestic hot water loads are small

DHW loads are fairly small compared to other end uses in these buildings, as demonstrated in the Oberlin and Zion end use data (see Figure 3-50 and Figure 3-51). DHW loads were responsible for 0.3 kBtu/ft² (3.4 MJ/m²) at Oberlin and 1.0 kBtu/ft² (11.4 MJ/m²) at Zion. Tankless water heaters at the TTF and solar collectors at CBF have successfully met the DHW loads.

Two natural gas tankless water heaters provide DHW for the kitchen and restrooms at the TTF. These units have an advertised thermal efficiency of 80%. These heat-on-demand systems were selected because they reduce energy consumption by diminishing standby tank losses, which can be 15% to 20% of a conventional system.

The solar hot water system at CBF consists of four arrays of 30 evacuated-tube solar collectors on the roof of the main building (see Figure 3-49). A glycol loop circulates fluid from the roof to two hot water tanks that are plumbed in parallel. One tank is for potable and the other for nonpotable water. The tanks have electric backup heaters. The system provides DHW for sinks, showers, two dishwashing machines, and a clothes washing machine. Because the overall water use is very low, all the DHW needs of the building are met by the solar collectors; the backup heating coils have never come on.



Figure 3-49 CBF evacuated-tube solar collector arrays

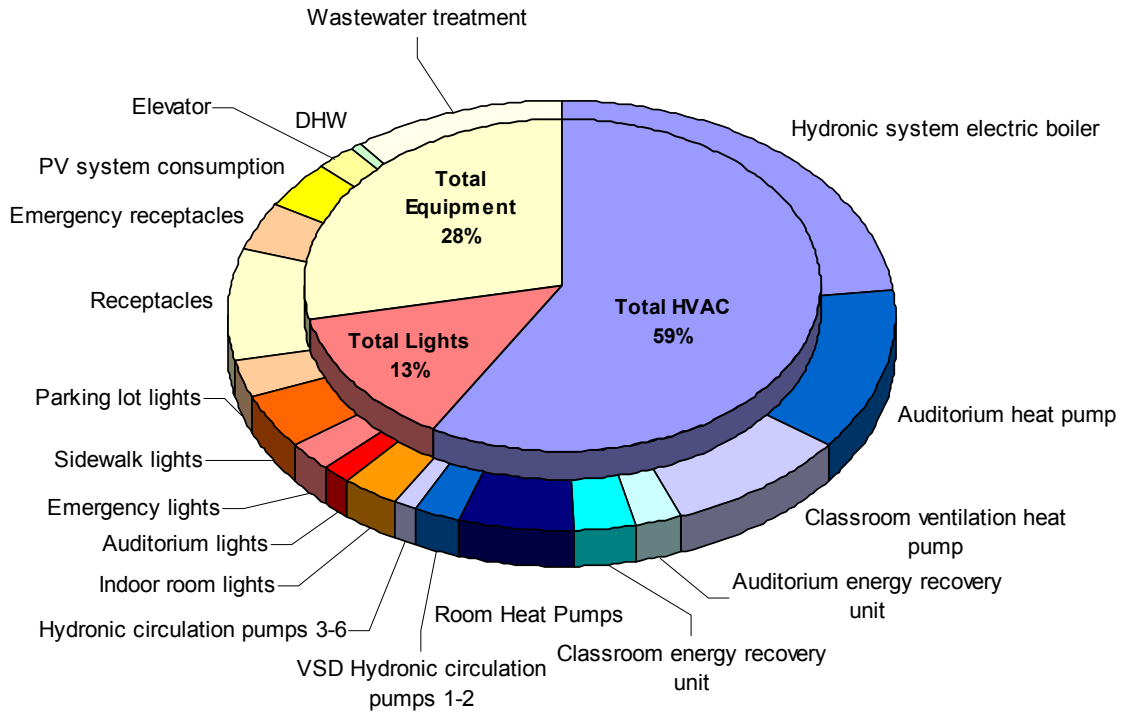

Figure 3-50 Oberlin energy end uses, 2002

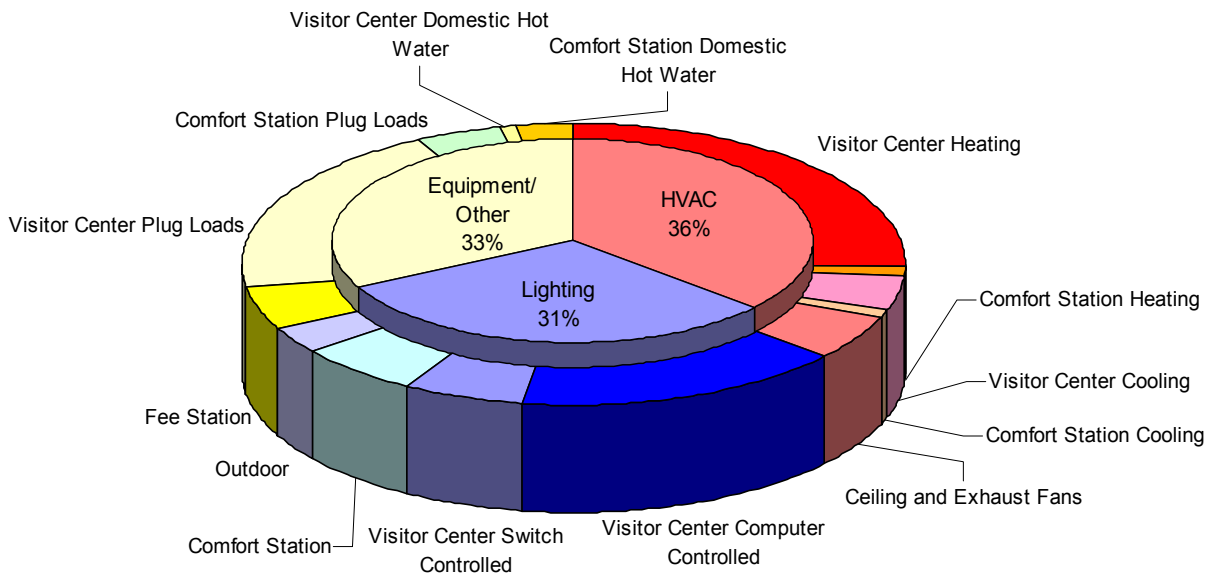

Figure 3-51 Zion energy end uses, 2002

3.7 Postoccupancy Evaluation Techniques

The purpose of the postoccupancy evaluation (POE) case studies was to determine actual energy performance of current generation of low-energy buildings to verify design goals and document real-world energy savings. Additionally, the POEs provided lessons learned in the design, technologies, operation, and analysis techniques to ensure these and future buildings operate at a high level of performance over time. A whole-building POE should consist of a combination of monitored energy use data and hourly building simulations. The POE for each case study included measuring actual energy performance of the building for at least a year during typical occupancy, simulating calibrated as-built and baseline models, and calculating whole-building energy savings. Additionally, specific technologies, including daylighting, HVAC, and PV systems, were evaluated in each building. Each POE provided valuable feedback to maintain or improve building performance. A POE is similar to equipment commissioning, but on a whole-building scale during occupancy. Standard equipment commissioning is valuable, but it does not guarantee each component will perform properly as part of an efficient system.

3.7.1 Determining whole-building energy savings

When discussing low-energy buildings, it has become common to characterize performance with the term *percent savings*. A calibrated as-built simulation compared to a conventional base-case model can provide a confident prediction of annual site, source, and cost savings. For each POE, we attempted to determine energy savings according to the following method:

1. Monitor site weather conditions and energy use for the whole building and at each end use over a year during typical occupancy. Aggregate end uses by HVAC&L and equipment/plug loads. (See Section 3.7.2 for details on measuring energy use.)
2. Update the design model to reflect as-built features and operation. Verify that the as-built model represents actual performance, which may require calibrating the as-built simulation, driven by measured weather data, to ensure confidence in the model. (See Section 3.7.1.3 for details on the calibration process.)
3. Extract calibrated schedules and equipment loads from the as-built model for use in the baseline model. Process loads, operational schedules, and set points should be the same in the baseline and as-built models to ensure a fair comparison. No credit should be taken for differences in building function or operation.
4. Determine annual site energy use, source energy use, and energy costs for both the calibrated as-built model and the updated baseline for a typical weather year.
5. Compare annual predictions of the calibrated as-built and baseline models to determine site energy use savings, source energy use savings, and energy cost savings.

This method is outlined in Figure 3-52.

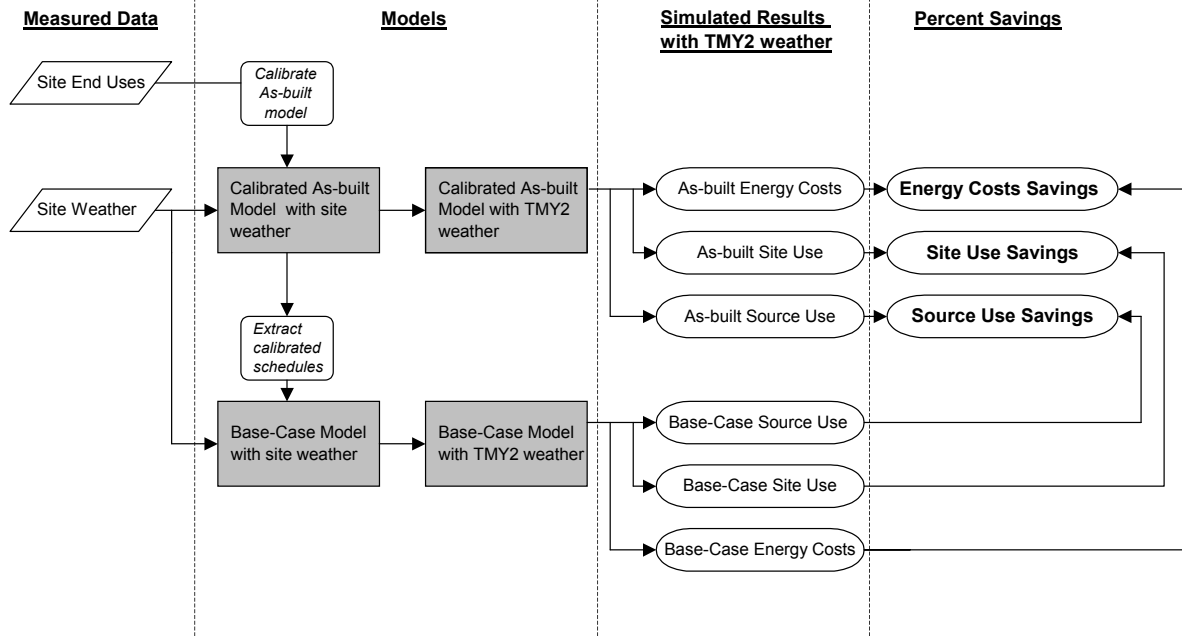

Figure 3-52 Evaluation flow chart comparing as-built to baseline models

Energy cost savings were set as the design goal for four of the six buildings. Energy cost saving design goals from 60% to 80% were set for Zion, BigHorn, TTF, and Cambria. Oberlin set a site energy savings goal and CBF set a LEED platinum design goal. (See Section 3.1.2.2 for further discussion of performance-based design goals.) If the team sets energy cost saving goals during design, verifying these design goals during actual operation may be difficult because energy prices can change. At BigHorn, natural gas prices varied by 40% during the three-year monitoring period and electrical prices varied widely, mainly because of new pollution regulations and a partial shift from coal to natural gas for electricity production. Site or source energy savings goals are easier to measure and typically are less susceptible to external fluctuations such as energy prices.

In each case where currency units are used, the years during which the expenditures occurred, as well as the utility rates during the period of energy costs reporting, should be noted. When energy costs are compared between two buildings that have been analyzed at different times or in different places, several factors may bias the comparison. These include:

- Changes in energy prices over time
- Differences in energy prices from place to place
- General inflation during the time interval.

3.7.1.1 Source energy

There are two forms of site energy use, net and total, where *net* gives credit for on-site production from PV panels. Source energy use is determined from net site energy use with assumed multipliers. One way we have estimated these multipliers is to use yearly national averages for different energy sources. Electricity conversion efficiency was assumed at 31.1%. Natural gas and propane conversion efficiency is assumed at 93.3%. The level of these assumptions was determined from data in the Energy Information Agency's *Annual Energy Outlook* (EIA 2005). In this report, source energy consumed for electricity is determined from net (purchased) electricity, which gives credit for the PV generated on site. (See further discussion on complexities of calculating accurate source energy multipliers in Appendix A.) *The Procedure to Determine Source Energy and Emissions for Energy Use in Buildings* (Deru and

Torcellini 2005a) provides additional source energy multipliers by the three interconnect regions in the United States.

Table 3-13 2004 Site-to-Source Energy Conversions

Energy	Source-to-Site Efficiency	Site-to-Source Conversion
Natural Gas	93.3%	1.072
Electricity	31.1%	3.215

Comparing the consumption of different forms of energy at the building site is difficult. For example, heating with gas, electricity, or district heat cannot be compared, because electricity and district heat are nearly 100% efficient. This comparison does not account for the energy used to generate and deliver the electricity or district heat to the site. A better comparison is to calculate the source (or primary) energy used to generate and deliver the energy to the site. But many of the important issues necessary to calculate source energy, including energy source mix, generation efficiencies, and distribution and transmission efficiencies, are often unknown at the local utility level. Time-of-day and season can also change the source-to-site conversion efficiency (CEC 2005). A solution is to use primary energy based on total energy generation and consumption data for the United States. Using national average data is a good approach because the energy distribution network in the United States is highly interconnected. National energy data are compiled by EIA (2005). The site-to-source conversion efficiencies for natural gas and electricity are shown in Table 3-13.

The delivery efficiency of natural gas for 2004 was approximately 93.3%, or the source energy is 1.072 times the site energy consumption. This number represents the total natural gas delivered to the consumers divided by the total consumption of natural gas. The inefficiency in delivery represents natural gas consumed at the well, in processing plants, and in distribution. However, the number does not account for other energy forms such as gasoline, diesel fuel, and electricity, which are consumed in extracting, processing, and distributing products. The magnitude of these other energy forms is not easily obtainable and would require a full life-cycle assessment of the natural gas extraction-to-delivery process. The information used here comes from Diagram 3, Natural Gas Flow, 2004 in the *Annual Energy Review 2004* (EIA 2005).

The average generation and delivery efficiency of electricity for 2004 was approximately 31.1%, or source energy is 3.215 times site energy consumption. Electricity efficiency is calculated by dividing end-use electricity by energy consumed to generate electricity and accounts for conversion, transmission, and distribution losses. It is based on the average of all sources of electricity generation and distribution in the nation, as reported in the *2004 Annual Energy Review* (EIA 2005). This number does not account for precombustion energy—energy to extract, transport, and process fuels used to generate electricity.

3.7.1.2 Baseline modeling

Everyone wants to report the percent savings for a building as a metric. The first problem with this is determining the baseline. Most often, baselines are based on a comparable code-compliant building. For the six buildings studied, this baseline varied from ASHRAE 90.1-1999 (ASHRAE 1999) to 10 CFR 435. (See Table 3-14 for the baseline energy code used for each case study.) The baselines included all process, equipment, and plug loads that were in the as-built model, even if design goals were determined against HVAC&L. For consistency, most of the buildings were compared to ASHRAE 90.1-2001. Although it is consistent, it forces one to ask, “Is it fair to evaluate a building against a standard that is higher than the original code that the building was designed against?” On the other hand, evaluating a building for its performance against old standards will not move low-energy design forward. The lack of a standard comparison technique points to the conclusion that there is a real need to create a standard benchmark. DOE’s residential program has established a benchmark for Building America, and a similar

tool is needed for commercial buildings. A first step in establishing a standard commercial building's benchmark is a procedure developed in the Performance Metrics task, *Procedure for Developing a Baseline Simulation Model for a Minimally Code-Compliant Commercial Building* (Pless, Deru, and Torcellini 2005). This procedure documents assumptions and identifies modeling inputs necessary for simulating a baseline for comparison purposes, from predesign through postoccupancy. We used baselines to analyze energy performance for buildings from predesign stages to postoccupancy as-built buildings. When building designs and operations change, the baseline has to evolve along with the building under consideration.

Energy savings uncertainties can be minimized when savings are determined from the comparison of one simulation to another simulation (e.g., baseline to as-built). Because difficult-to-know inputs are held the same in both simulations, such comparisons remove much of the uncertainty inherent in an hourly building energy simulation. Variables that change throughout the year, such as inconsistent occupancy, set point changes, and equipment performance degradation, are difficult to account for in an annual building energy simulation. Comparing a baseline model to an as-built model with the same schedules reduces the uncertainty.

3.7.1.3 Model calibration process

To calculate energy savings of a building, a model must be calibrated against actual building data. Too many changes occurred to use the design-based models as accurate predictors of energy consumption. Schedules and plug loads vary widely from original assumptions. The baseline model must also be modified to reflect the as-built schedules and plug loads. A calibrated as-built simulation compared to a conventional baseline can provide a confident prediction of annual site, source, and cost savings. Using typical meteorological year weather data allows long-term savings calculations with relatively short-term data.

To verify that an as-built model and accompanying assumptions were adequate, the as-built model's energy performance was compared to the actual measured energy performance over a full year. For a proper comparison, the measured local weather data from this year was used as the weather file in the as-built simulation. Each of the primary measured end uses (HVAC&L and equipment) was compared to the simulated end uses for model calibration. To calibrate the model, assumptions such as heating and cooling schedules, occupancy schedules, and unoccupied infiltration were slightly tuned until the energy performance of the calibrated as-built model described the measured energy performance. We also used daily load shape profile comparisons of the lighting, equipment, and HVAC to ensure appropriate as-built model representation of daily use patterns. These calibrated schedules were also used in the comparison baseline model. For the model to describe the actual building energy performance within expected simulation accuracy, the difference between modeled and measured monthly energy totals should be less than 10%.

Where appropriate, specific measured equipment performance parameters were compared to simulated predictions. For example, in the Oberlin heat pump ground loop, actual flow rates, ground supply, and return temperatures were compared to simulated ground temperatures and flow rates. The highly variable and relatively unknown thermal properties of the ground were adjusted to ensure the simulated ground-source temperatures were similar to measured values. In general, the calibration process allows for greater confidence in the many modeling assumptions required to simulate whole-building performance.

3.7.1.4 Energy saving uncertainty

The uncertainty of the annual performance metrics based on simulations, such as the site energy saving and site EUI for a typical weather year, are difficult to estimate with direct calculations. The processes used in the POEs attempted to reduce uncertainty related to building simulations. To reduce the uncertainty of the annual simulation metrics, NREL calibrated the models with measured end uses and site weather. NREL considers a building simulation to be calibrated when the simulated monthly end uses (heating, cooling, lighting, equipment) is within $\pm 10\%$ of the measured monthly energy use. This

±10% criterion can be assumed to represent a base level of uncertainty in annual performance metrics based on simulation results.

Input perturbation methods can also be used to model the uncertainty in whole-building energy simulations, but these methods require an extensive level of effort to prepare hundreds of input files and process results. Such efforts have produced error estimates of about ±14% (Griffith et al. 2005). Based on these two methods, NREL estimates the uncertainty of the annual performance based on simulation (site energy use, source use, and energy costs) to be ±12%. Although not quantified, uncertainties are much lower for percent saving metrics (site energy savings, source energy savings, and energy cost savings), which result from comparing one simulation to another.

3.7.1.5 *Alternative methods*

For each POE, the ideal whole-building evaluation technique was to compare the baseline site energy use, source energy use, and energy costs to an as-built model to calculate savings for a typical weather year. Although this method is very straightforward, several issues surfaced when we attempted to determine energy savings for each building. For Zion and CBF, we were only able to compare the actual measurements to a well-calibrated baseline model because of limitations in the whole-building simulation tools. We used monitoring data for weather and operational schedules to develop a baseline model of a conventional energy code-compliant building. We attempted to account for the inherent uncertainty involved in comparing measured data to a simulation by calibrating the baseline model with measured weather data, measured equipment loads, and operation schedules. Table 3-14 shows the energy savings calculation method used for each case study.

At CBF, an as-built model of the building could not be developed for this project because of the complexity of the HVAC systems and the late addition of water source heat pumps in EnergyPlus. In the analysis of Zion, an as-built model was not completed because of limitations in DOE-2.1E modeling capabilities. These limitations include nonexistent building integrated modeling techniques for the energy use and cooling capacity of cooltowers, difficulties modeling the as-built operation of subhourly demand-responsive controls with integrated PV production, and uncertainties with Trombe wall thermal models. The flow chart in Figure 3-53 shows how the measured data were used in the models and the process used to obtain the simulation results for Zion and CBF.

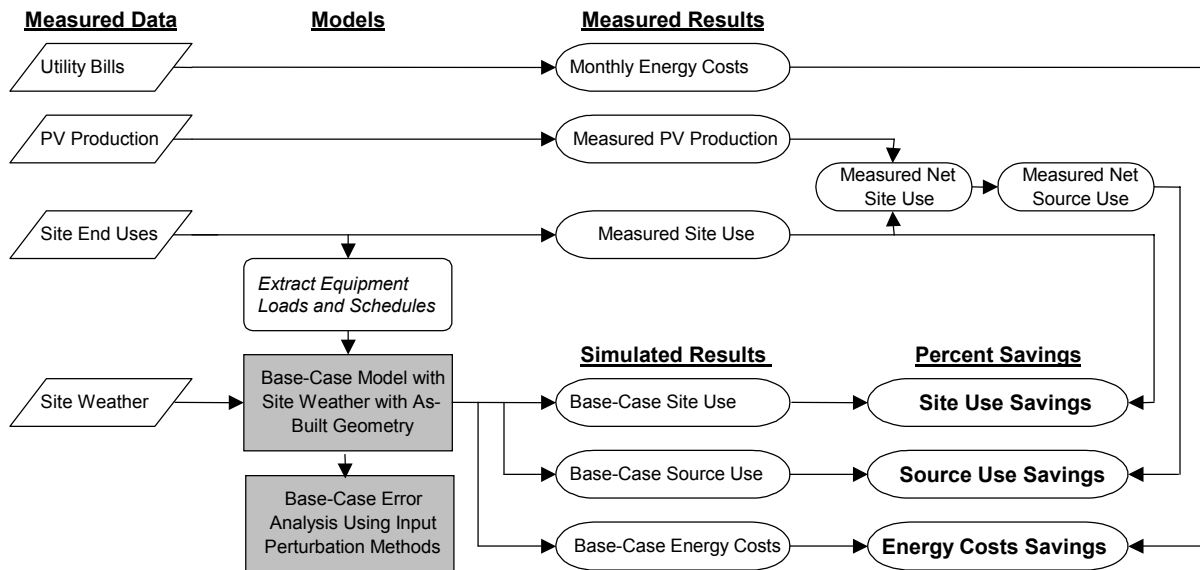

Figure 3-53 Evaluation flow chart comparing measured data to baseline model

Difficulties with modeling as-built energy costs at Oberlin resulted in a similar evaluation technique. Measured energy costs were compared to baseline energy costs to determine energy cost savings. Although we were able to adequately model as-built and baseline site and source energy use, the limitations of the DOE-2 simulation program prevented us from modeling the as-built energy costs and accurately predicting peak demands on a 15-minute time step with integrated on-site generation. The peak demand modeling limitation also prevented us from developing and quantifying savings of demand-responsive controls that enable on-site PV production to reduce peak demand and optimize energy costs.

Another method of characterizing energy savings levels is to consider only the energy used for HVAC&L by removing that energy used by the occupants. This method of comparing energy use was used in the Energy Cost Budget of ASHRAE Standard 90.1-2001 (ASHRAE 2001). The USGBC has also used this method in its original LEED V1.0 rating system. However, some researchers and professionals in the building industry disapprove of this method because it tends to overstate the level of savings and overlook critical energy efficiency opportunities in reducing plug and equipment loads. In addition to whole-building energy savings, HVAC&L savings (without equipment loads) were determined for the TTF and CBF for an assessment of design predictions. The energy savings design goals for the TTF and CBF were determined without considering plug loads. A significant difficulty arises when we try to remove plug loads from the energy costs because of their contribution to demand charges. Therefore, energy costs without plug loads were modeled by subtracting the contribution from plug loads from the overall costs using a virtual electricity rate that was determined from a year of billing data.

Although the methods used to determine actual energy savings used are straightforward, several issues arose during the evaluation of the case studies, limiting the application and consistency of the evaluation techniques. These issues points to the need to develop a standardized process that can be consistently applied to measuring energy savings in commercial buildings. A standardized process would include guidance for combining Appendix G of 90.1-2004 (ASHRAE 2004) with measured energy performance end use data to report measured energy savings of occupied buildings.

Table 3-14 Postoccupancy Evaluation Techniques Summary

	Oberlin	Zion	Cambria	CBF	TTF	Bighorn
Site, Source, and Cost Savings Calculation Methods	For site and source savings calibrated as-built model compared to baseline model with typical weather. For energy cost savings, utility bills compared to baseline model run with measured weather file	Measured energy use compared to baseline model run with measured weather file	Calibrated as-built model compared to baseline model run with typical weather file	Measured energy use compared to baseline model run with measured weather file	Calibrated as-built model compared to baseline model run with typical weather file	Calibrated as-built model compared to baseline model run with typical weather file
Whole-Building Simulation Tools	DOE-2.2 (PowerDOE)	DOE-2.1E	DOE-2.2 (PowerDOE)	EnergyPlus V1.1	DOE-2.1E	DOE-2.1E
Baseline Codes	ASHRAE 90.1-2001	ASHRAE 90.1-1999	ASHRAE 90.1-2001	ASHRAE 90.1-2001	1995 Federal Energy Code 10 CFR 435	ASHRAE 90.1-2001
Energy Monitoring Methods	Two dedicated data loggers	EMS	Dedicated data logger for PV and indoor space conditions PowerLogic and utility meters for electrical measurements	Two dedicated data loggers	EMS combined with PC for data logging	Originally EMS, upgraded to dedicated data logger

3.7.2 *Measuring energy use*

Monitoring end uses over a full year can be expensive, but it is critical for identifying problem areas and providing feedback to facility operators and building designers on actual performance versus predicted performance. Measured performance is necessary for documenting real-world energy savings and provides a means for validating energy simulation models. Each building was monitored for at least a year during typical occupancy.

3.7.2.1 *Develop a performance monitoring plan*

A key first step for each monitoring system installed was to determine a performance monitoring plan. The monitoring plan should be carefully laid out early, beginning with a list of specific questions the evaluation will address. The most suitable performance metrics are then chosen, which leads to the data and analysis techniques required. This plan ensures that unneeded data and the associated expense of excessive measurements will not be incurred. Guidance for monitoring and reporting the energy performance of commercial buildings can be found in the *Procedure for Measuring and Reporting Commercial Building Energy Performance*.

An example of an energy monitoring plan follows:

The overall goal of the energy monitoring analysis was to measure and evaluate the building energy use patterns. This goal was broken down into the following objectives for the energy-monitoring plan:

1. Evaluate the whole-building energy performance and compare this with the design expectations.
2. Analyze the monthly electrical demand and cost profiles.
3. Evaluate the lighting system performance, including the effects of daylighting.
4. Evaluate the PV system performance.
5. Compare the building energy performance to a building that meets the minimum standards of the energy code.
6. Generate a list of lessons learned to apply to other buildings.

To satisfy these objectives, a data monitoring plan was developed and the following measurements were taken:

- Surveys of electrical equipment in the building, including spot measurements of power
- Monthly building utility bills for natural gas and electricity
- Total electrical energy at 15-minute increments
- Sub-metering of major electrical energy end uses at 15-minute increments
- Electrical energy delivered to the building by the PV system in 15-minute increments
- Temperature and flow of the radiant floor water loop
- Solar radiation incident on the PV system and temperature of the PV cells.

3.7.2.2 *Data logging systems*

The data acquisition systems (DAS) used to monitor energy performance in the case study evaluations at Oberlin, BigHorn, Cambria, and CBF consisted of Campbell Scientific data loggers with battery backup, various pulse and voltage measurement multiplexers, a network or modem interface, and all the necessary sensors for measuring electrical and gas energy flows. The monitoring equipment for the electrical measurements consisted of current transformers (CTs) and watt-hour transducers. The CTs were sized based on the expected load on the circuits from the building electrical drawings, rather than breaker capacity. The watt-hour transducers have a pulse output relative to the energy consumed by the circuit.

The data loggers take measurements every 20 seconds and report totaled or averaged results every 15 minutes. Electrical systems should be monitored with watt-hour (energy) meters and not pure watt (power) meters. Watt meters that are read every 15 minutes provide only a snapshot of the instantaneous power and do not give a true measure of the energy used over the previous 15 minutes.

At Oberlin, during the two-year period of monitoring minute and hourly end-use data, 0.6% of the collected hourly data were incomplete or missing using dedicated data loggers. Of the 56 variables that were collected on an hourly basis, only 6,000 data points were missing or incomplete over the two years. At CBF, the measurements with the dedicated data loggers were reliable with no periods when data were lost or uncollected.

We used the EMSs at Zion and TTF to collect energy performance data. Table 3-14 shows the data logging system used for each case study. For the monitoring systems that used the EMS, frequent downloads to personal computers were required to archive continuous energy use data because the EMS had limited memory dedicated to data storage. Additional data parsing and management were also required because some data formats were difficult to process. At the TTF, we had difficulties with the long-term reliability of custom archiving routines and EMS to PC communications. We had limited success at Zion with long-term data archiving to a remote PC, which required considerable operator oversight. The process required automatically scheduled download of trend logs twice daily, processing trend files, and archiving performance data in a usable format.

EMS data collection, logging, and retrieval methods were problematic and should be avoided. With current EMS and building automation systems there appears to be a low probability of obtaining contiguous, error-free, measured data sets over a long period. A better solution is to use dedicated, self-contained DAS that are designed for unattended remote operation and do not use operating systems designed for PCs.

Initially, the watt-hour transducers at BigHorn were connected to the building EMS for data logging purposes. However, using the EMS to log data caused many difficulties. First, the format of the data was difficult to process. Second, downloading and archiving the data were difficult. Finally, the system has limited memory dedicated to data storage, which resulted in lost data. For these reasons, a dedicated data logger was used for all the instrumentation installed by NREL. It was connected to a cellular phone for remote access and the all the data storage and retrieval operations were automated.

Although using the EMS for datalogging was problematic, direct access to the building controls was beneficial to researchers for understanding and influencing how the building was being controlled. At Zion, researchers had access to the EMS. Researchers were able to improve energy management strategies such as implementing and testing various demand-responsive strategies. Access to the EMS allowed us to reduce the demand charges to the building and facilitated continuous commissioning activities. Another advantage is that EMS access and control provide a full understanding of the various set points and control strategies to use as inputs into building energy simulation.

3.7.2.3 Data acquisition system accuracy

Setting up the monitoring system to allow for an energy balance calculation was important for ensuring monitoring system accuracy. An energy balance at the main distribution panel was used as the error checking procedure to verify that each meter was measuring properly. The energy balance helps identify any errors in the metering installation and DAS programming. Figure 3-54 illustrates an example of this check and shows the overall accuracy of the metering system.

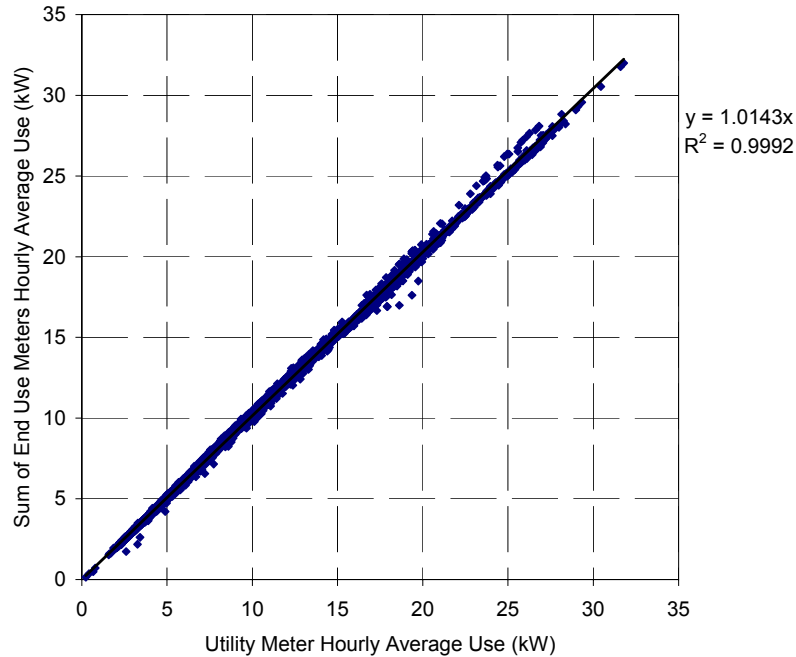

Figure 3-54 Energy balance of calculated building electricity end uses versus utility meter electricity supply

The expected accuracy of the sensors used in each monitoring system is determined from product specifications and is shown in Table 3-15. Individual electricity measurements are $\pm 0.5\%$ based on the manufacturer's data. Totaled values are a summation of individual measurements, but the errors are assumed to be independent and to not increase the level of uncertainty. Based on the expected uncertainty of the energy use measurements and the reliability of the long-term DAS, NREL expected the uncertainty of the annual performance metrics based on measured energy use to be $\pm 1\%$.

Table 3-15 Measurement Type Accuracy

Measurement Type	Sensor Accuracy
WattNode watt-hour meter for electrical end use measurements	$\pm 0.5\%$
Standard type T thermocouple for PV cell temperatures, ERV air temperatures, and heat pump ground loop temperatures	$\pm 0.5^\circ\text{C}$
Temperature and RH probes for ambient, atrium, and wastewater treatment environmental conditions	$\pm 3\%$ RH for 10–90% RH, $\pm 6\%$ for 90–100% RH, 0.5°C
Empro DC current shunts for DC current of PV Systems	$\pm 0.25\%$
Voltage dividers for DC voltage of PV system	$\pm 1.0\%$
LiCor solar radiation pyranometer for outdoor horizontal and vertical insolation	$\pm 5.0\%$

3.7.2.4 *Site weather conditions*

Weather information is important for high-performance building projects that are often more weather dependent. Preferably, weather data should be measured on site, but a nearby reliable weather station with the required data can also be used. On-site weather data are needed in the as-built model calibration process and was valuable for modeling baseline performance when an as-built model was not simulated. Monitored weather at each building included:

- Dry-bulb ambient temperature
- Relative humidity
- Global horizontal solar radiation
- Wind speed and direction.

The global horizontal solar radiation is the most useful solar radiation measurement. Most simulation programs are written to use this value of solar radiation along with direct normal and horizontal diffuse, both of which can be estimated from the global horizontal value combined with a cloud cover variable. If the measurement plan includes a PV system, measuring the solar radiation in the plane of the PV panels may be useful. If two pyranometers are available, both the global horizontal solar radiation and the PV plane solar radiation should be measured.

3.7.2.5 *Plan for monitoring system during design*

The electrical panels should group like loads, such as HVAC, lighting, and plug loads. The electrical panels at BigHorn are not well organized, which made it difficult to operate and maintain the building and extremely difficult to monitor energy performance by end use.

Because CBF and Oberlin were built before the monitoring effort was conceived, flow meters could not be installed on the ground loop. Flow rates and loop temperatures are required to measure energy rejection or extraction from the ground. The initial measurement plan called for ultrasonic flow meters to monitor the flow rates, but the pipe configuration was not suitable. Future monitoring efforts on buildings with ground-source loops should attempt to change or otherwise influence mechanical plumbing designs so that relatively long, straight, horizontal sections of pipe are available to form suitable locations for ultrasonic flow meters. An alternative is to design and install flow meters as part of the system design.

3.7.2.6 *Filling missing data*

Using a dedicated monitoring system to collect evaluation data was functional, practical, and very reliable. The reality of long-term experimental research is that missing data are possible even with reliable and dedicated equipment and sensors. A typical error was a missing hour of all end-use variables. To account for this type of error, NREL inspected diurnal, weekly, and seasonal patterns in the end uses, combined with a driving variable, such as weather and occupancy, to estimate the missing data points.

3.7.3 *Daylighting evaluations*

The lighting systems in each building were evaluated to determine the energy savings and to evaluate the quality of the light delivered by the lighting design. The *Procedure to Measure Indoor Lighting Energy Performance* (Deru et al. 2005b) provides performance metrics for evaluating lighting design, including daylighting. The goals of the daylighting evaluations were to:

- Measure the energy consumption by the lighting systems.
- Determine the energy savings that result from the lighting design without daylighting controls.
- Determine the amount of electric lighting offset by daylighting and the energy saved in lighting.
- Analyze the operation of the lighting design and optimize its performance.

- Quantitatively assess the quality of the lighting and daylighting designs.
- Document the successes and weakness of the lighting design.

Seasonal illuminance measurements were taken as recommended in the International Energy Agency protocol established under Daylight in Buildings Task 21 (Atif et al. 1997). Daylighting was measured with photometers to evaluate how well the building is lit by daylight that enters the building through the windows. In contrast to continuous monitoring over a year, we obtained these ancillary measurements over short periods and used a mixture of handheld and continuous measurements, which were closely supervised by researchers. The intent of this analysis is to understand how well this resource is being used by determining the extent to which daylight might meet the lighting needs. Recommended illuminance levels for each lighting zone were determined in accordance with the *Lighting Handbook of the Illuminating Engineering Society of North America* (IESNA 2000). Recommended lighting levels are 30 to 50 f.c. (300 to 500 lux) depending on space type, and where daylight can provide the recommended lighting levels, the analysis shows where electric lighting can be reduced.

Daylighting was measured over the course of three site visits at different times of the year. The measurements include horizontal illuminance in selected daylit zones during varying sky conditions for typical summer, winter, and fall/spring seasons. External horizontal illuminance and electrical lighting energy use had to be monitored simultaneously to complete the daylighting measurements. During each visit, data loggers were set up to continuously collect data from photometers at 5-minute intervals. Additional measurements were taken with handheld photometers to collect supplementary data that cover a wider distribution of locations in the building.

As each building has a low LPD, ensuring that the daylighting and lighting systems can provide recommended illuminance levels is important. We want to avoid claiming daylighting savings when lights are off and illuminance levels are lower than recommended. The seasonal illuminance measurements, both handheld and 5-minute continuous interval, were necessary to verify that the lighting systems (daylighting combined with electrical lighting) could provide sufficient lighting levels.

3.7.4 PV systems evaluations

The PV systems in each building were evaluated to determine the energy they produced, their effect on the building purchased electrical energy, and their performance. The *Procedure for Measuring and Reporting the Performance of Photovoltaic Systems in Buildings* (Pless et al. 2005) provides guidance on evaluating the performance of PV systems in the built environment. Additional measurements were taken for a more detailed evaluation of the system performance. Evaluations of PV systems in future buildings should:

- Measure the delivered energy production from the PV system.
- Determine the percentage of the building electrical energy consumption offset by the PV system.
- Determine building electrical demand offset by the PV system and the energy cost savings.
- Determine the performance of the PV system compared to the expected performance.

Bidirectional electrical meters are required to determine net PV energy production. Standby losses can be a significant portion of the total PV system production that requires electrical energy meters that can measure energy to and from PV systems. Additional PV measurements that are valuable for system analysis included insolation in the plane of the PV array and PV module operating temperature. Short-term current-voltage measurements were valuable for understanding maximum power point settings.

All PV systems were modeled with an annual modeling tool to evaluate measured energy production and to identify and quantify system degradations. We used the PV system simulation tool PVSyst v3.3 (Mermoud 1996) to calculate the expected annual performance of the PV system and determine the

effects of degradations on total output. Inputs to this model include PV panel size and operational characteristics, inverter size and operational characteristics, array configuration and wiring details, array tilt and azimuth, and hourly weather data. System specific inputs such as shading and array wiring losses were also simulated. The simulation approximated the cell temperatures based on the default thermal properties of the specific mounting configuration. When available, measured PV cell temperature was used to calibrate the site-specific thermal properties of the mounting configuration.

Hourly or 15-minute data were collected for all PV systems. One-minute data were also collected for system diagnostic purposes. Careful examination of the Oberlin PV system performance shows the value of collecting PV performance data on a 1-minute interval. On some days, the inverters would shut down repeatedly for short periods (Figure 3-55). Daily hourly average power production data appeared to show that a cloud had passed by in mid-afternoon, not that there was a system performance issue. The system performance problem was seen when the minute-by-minute performance data were reviewed. On cool, sunny days, the PV system supplied more power to the inverter than it could invert. The result was an overvoltage fault that temporarily shut down one, two, or all three inverters for 5 minutes at a time.

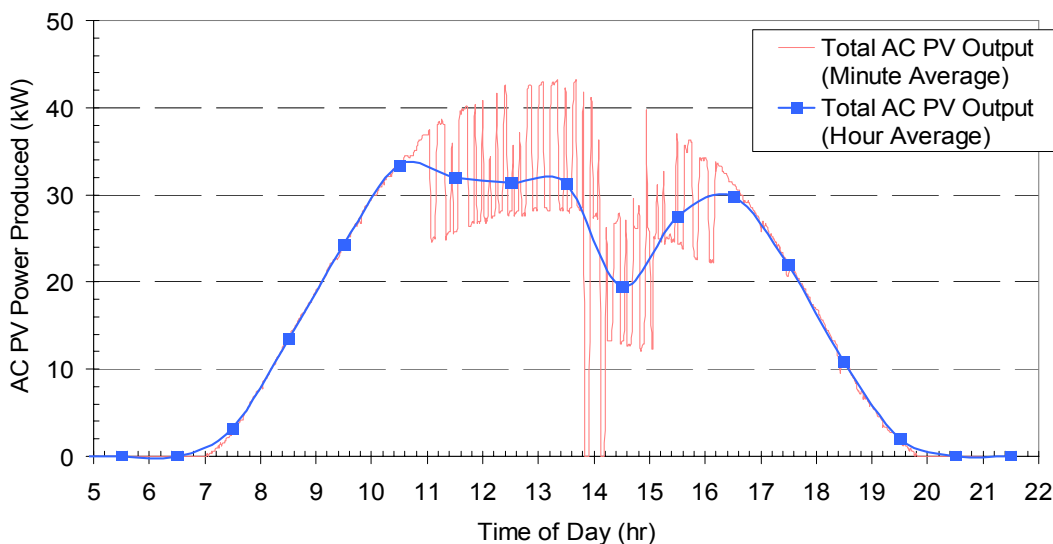

Figure 3-55 PV AC power output for Oberlin’s three subarrays on April 28, 2001

3.7.5 Performance metrics

Obtaining reliable metrics to determine a building's performance is one of the core challenges to achieving widespread adoption of high-performance buildings. Building professionals should plan to implement the measurement procedures as described in DOE’s Performance Metrics Research Project. The current suite of procedures was developed in parallel with the case studies, as the need for standardized procedures and metrics was evident early in the POE process.

Currently available procedures for determining performance metrics include:

Procedure for Measuring and Reporting Commercial Building Energy Performance

The purpose of this procedure is to establish a standard method for monitoring and reporting on the energy performance of commercial buildings. It determines the energy consumption, electrical energy demand, and on-site energy production in existing commercial buildings of all types for the facility and end uses. The performance metrics determined here may be compared against benchmarks to evaluate performance and verify that performance targets have been achieved. This procedure includes definitions of the performance metrics obtained, detailed steps for quantifying performance, and a list of suggested monitoring equipment (Barley et al. 2005). Uses may include:

- Compare performance with the design intent.
- Compare performance with other buildings.
- Evaluate building performance rating systems.
- Perform economic analysis of energy-efficient strategies in buildings.
- Establish long-term performance records that enable maintenance staff to monitor trends in energy performance.

Procedure to Measure Indoor Lighting Energy Performance

This document provides standard definitions of performance metrics and methods to determine them for the energy performance of building interior lighting systems. It can be used for existing and proposed buildings. Typical results from the use of this procedure are the monthly and annual energy used for lighting, energy savings from occupancy or daylighting controls, and the percent of the total building energy use that is used by the lighting system. The document is not specifically intended for retrofit applications. However, it does complement measurement and verification protocols that do not provide detailed performance metrics or measurement procedures (Deru et al. 2005b).

Procedure for Measuring and Reporting the Performance of Photovoltaic Systems in Buildings

This procedure provides a standard method for measuring and characterizing the long-term energy performance of PV systems in buildings and the resulting implications to the building's energy use. The performance metrics determined here may be compared against benchmarks for evaluating system performance and verifying that performance targets have been achieved (Pless et al. 2005). Uses may include:

- Compare performance with the design intent.
- Compare with other PV systems in buildings.
- Economic analysis of PV systems in buildings.
- Establish long-term performance records that enable maintenance staff to monitor trends in energy performance.

Procedure for Developing a Baseline Simulation Model for a Minimally Code-Compliant Commercial Building

This procedure provides a standard method for developing a baseline simulation model of a minimally code-complaint commercial building for the purposes of whole-building energy simulations. It provides various classifications of baselines based on the design and operation status of the building under construction. Three major baselines are defined: Pre-Design, Proposed Design, and Existing Building. The procedure also tells users how to use each of these three baselines with an integrated design process (Pless, Deru, and Torcellini 2006).

Standard Definitions of Building Geometry for Energy Evaluation Purposes

This procedure provides definitions and metrics of building geometry for use in building energy evaluation. Building geometry is an important input in the analysis process, yet there are no agreed-upon standard definitions of these terms for use in energy analysis (Deru and Torcellini 2005). The metrics can be used to:

- Characterize building geometry.
- Calculate energy performance metrics.
- Conduct energy simulations.

Procedure to Determine Source Energy and Emissions for Energy Use in Buildings

This procedure provides the fuel and emission factors to calculate the source (primary) energy and emissions for electricity, fuels, and thermal energy delivered to a facility, and combustion of fuels at a facility on an annual basis. The fuel and emission factors provided in this procedure account for the energy and emissions associated with extracting, processing, and delivering the fuels to the electrical power plants or directly to the buildings. In addition, the breakdown of the fuel used to generate electricity is provided on the national level, three interconnection levels, and the state level for Alaska and Hawaii (Deru and Torcellini 2006).

4 CONCLUSIONS

Each of these six commercial buildings has its unique purposes and functions, and all have commonalities. All must provide protection against varying climatic conditions and acceptable comfort for the occupants. The six buildings in this study are successful in these respects, and they are all good energy performers. All had owners who pushed low-energy or sustainability goals and considered energy efficiency as part of the decision-making process. The architects and engineers then met and implemented the vision. This vision required an integrated design process to achieve the goals. All the buildings use innovative energy technologies to reduce their energy use and minimize their environmental impacts. Some use technologies that may seem inapplicable to other types of buildings. However, there is substantial evidence that these buildings represent a broad cross-section of the commercial sector. Direct replication is not possible, as each commercial building is unique. One must think of how these technologies might adapt to the design of other commercial buildings.

Examples of this replication thought process might include:

- TTF is a steel frame building typical of much of the commercial one-story building stock. Daylighting, evaporative cooling, enhanced thermal envelope, and overhangs would work well in similar structures.
- The Zion Visitor Center is an excellent example of a small retail space, and of museum and park visitor centers that can easily be replicated.
- The Zion Comfort Station is a good example of a rest area facility and any restroom in any building.

Significant energy savings were realized for this set of low-energy buildings constructed in a wide range of climates in the United States. We found that the buildings' energy consumption was 25% to 70% lower than code. At current levels of performance, the one-story buildings—Zion, BigHorn, and TTF—could accomplish the ZEB goal with PV systems on their roofs. ZEBs are not feasible for the two-story buildings within their footprints unless their loads are reduced further. Further ZEB analyses and definitions are provided in Appendix A.

Each case study report developed a list of lessons learned and recommendations relevant to that unique building. This report combines the overarching lessons learned. Although the case studies represent a variety of designs and climates, we stepped back and looked at all six together to understand common successes and failures. We then distilled successes and failures and other wisdom acquired along the way into a set of *lessons learned*.

The term *lessons learned* refers to positive and negative aspects of a project that have clear messages and might help subsequent low-energy building projects. The lessons learned are intended as recommendations and best practices, either for changes to these buildings or for concepts that should be applied to the next generation of low-energy buildings. Members of future building projects should keep these lessons in mind and realize that they should be considered jointly along with the goals for saving energy. Lessons learned are key educational components. They should help design teams avoid repeating problems and identify where the process of delivering buildings needs to be changed to promote and realize low- and zero-energy buildings.

We then used these buildings and their lessons learned to help identify and define a set of *best practices*—design elements and techniques that should be avoided in commercial buildings, as well as elements that should be carried forward to additional buildings. Best practices are proven, real-world technologies and processes that can lead to high-performance commercial buildings.

4.1 Lessons Learned

Lessons learned from these projects, from the design process through the operation of the building, will help to improve all buildings. Based on good design and effective operation, buildings can be constructed

that use significantly less energy than code-compliant buildings. As with all building projects, not everything the design teams desired was achieved.

4.1.1 Applying a whole-building energy design process

Each building established energy goals from the beginning of the design process and saved energy as a result. Whole-building energy simulations were a great help in goal setting, informing the design process, and evaluating the impact of design and construction decisions. The envelope was designed first, and the remaining loads were met with HVAC equipment. Successful daylighting was vital to reducing lighting and HVAC loads.

Measured data provided valuable feedback to building owners and design teams about the success of their buildings. The monitoring results were used to compare results against the goals and identify areas that needed to be corrected to improve the energy performance. All the buildings' energy performance benefited from postoccupancy fine-tuning of the system operations.

Based on our evaluations, here are the significant lessons learned related to the whole-building design process:

- **Owners provide the main motivation for low-energy buildings.** The owner was the driving force in each case. Each owner set the goals and made decisions to keep the project on track. The architects and engineers strived to meet the goals of the building owners, which resulted in the whole-building design process.
- **Setting measurable energy saving goals at the onset of the project is crucial to realizing low-energy buildings.** In the case studies, all the owners and design teams set aggressive energy saving goals at the outset. The goals ranged from 40% better than code to net-zero energy performance. Some also had ambitious goals about other dimensions of sustainability such as water management, building materials selection, or obtaining a high LEED score. People are motivated to achieve when they set the goals. Setting such goals enables owners to make decisions that align with the goals. In general, the teams that set the strongest energy performance goals and used energy simulation to understand the energy impacts of design decisions had the best energy performance. These projects show that defining specific, measurable energy saving goals early in the design process helps the design team achieve better results.
- **Many decisions are not motivated by cost.** Building owners make decisions based on values. Quite often owners will pay for features they really want in a building—this is especially true of architectural features. Conversely, if an owner does not want a feature, cost is often used as the reason to eliminate it.
- **Today's technologies can substantially change how buildings perform.** Properly applied off-the-shelf or state-of-the-shelf technologies are available to achieve low-energy buildings. However, these strategies must be applied together and properly integrated in the design and operation to realize energy savings. There is no single efficiency measure or checklist of measures to achieve low-energy buildings.
- **A whole-building design approach is a good way to lower energy use and cost.** An integrated whole-building approach begins with a design team that is committed to the energy goals. The building must be engineered as a system if the technologies are to be integrated in design and operation. The integrated design process starts with predesign and is applied through construction and operation, ensuring that the building is built to plan. Whole-building energy simulation is a great help in setting goals, informing the design process, and evaluating the energy impacts of design and construction decisions. The envelope should meet as many needs as possible and be the first method of creating a low-energy building. The mechanical and lighting

systems should provide the remaining thermal and lighting comfort needs. Low-energy architecture is not achievable if mechanical systems have to solve problems from inadequate envelopes.

The best way to reduce the cost of low-energy features and ensure successful integration is to incorporate them into the architecture early. If low-energy features such as daylighting, clerestories, or cooltowers can be integrated into the architectural statement, they can be included as part of the architecture costs.

The weak point in realizing low energy is not necessarily in the technologies, but rather in the lack of a widely used and cost-effective design and construction processes that can integrate these technologies from a systems engineering perspective. This process includes integrating the technologies with advanced control hardware and control sequences. The final step in the whole-building design process includes verifying postoccupancy performance so the building operates as designed. The probability that a low-energy building will be achieved is improved by adopting the whole-building design process.

- **Low-energy buildings do not always operate as they were designed.** The design community rarely goes back to see how their buildings perform after they have been constructed. Measurements in all six buildings showed that they used more energy and produced less energy than predicted in the design/simulation stage. Several reasons were documented.
 - There was often a lack of control software or appropriate control logic to allow the technologies to work well together. Appropriate control systems can successfully integrate the low-energy technologies and allow a building to operate at its design potential.
 - Design teams were a bit too optimistic about the behavior of the occupants and their acceptance of systems.
 - Energy savings from daylighting were substantial, but were less than expected.
 - Plug loads were often greater than design predictions.
 - Effective insulation values are often inflated when comparing the actual building to the designed building.
 - Thermal bridging was partially accounted for in the models during the design process, but construction details and specifications are not always implemented as designed; in some cases the designs did not include specifications about thermal bridging.
 - Operational failures in many energy-saving technologies go unnoticed because they have backups. Therefore, when these systems do not operate as intended, comfort is not affected. For example, if a daylighting sensor fails, sufficient lighting is still provided with the electrical lighting system, but the expected daylighting energy savings are not realized. Sophisticated submetering is often required for detection and to keep the systems operating properly.
 - PV systems experienced a range of operational performance degradations. Common degradation sources included snow, inverter faults, shading, and parasitic standby losses.
- **Monitoring leads to better management and improved performance.** Setting and following design goals or traditional commissioning does not guarantee that the goals will be satisfied in actual operations. The whole-building energy performance must still be tracked and verified. Many items, such as daylighting controls, PV system faults, and equipment sequencing were corrected because of the knowledge gained through metering and submetering. Especially with Oberlin, there was a dramatic improvement in performance with monitoring and correcting some problem areas identified by the metering. There is a performance gap between what today's

technologies have provided and the potential performance of state-of-the-shelf technologies. Commissioning a new building is essential, but it ensures only that the building components operate as specified. All six of these low-energy buildings were commissioned, formally or informally, before occupancy. Various degrees of advanced commissioning occurred during the postoccupancy monitoring as well. In general, the traditional commissioning did not translate to expected energy performance or verify low-energy design goals. Continual monitoring of the performance, or continuous commissioning with key performance metrics, is important to ensure that the goals of the design are met under normal operating conditions. In all the buildings, controls, equipment, and operation were all adjusted to better align the performance with the design goals.

- **This set of current generation low-energy buildings shows progress toward achieving a ZEB goal in actual buildings.** Each of these buildings saved energy, with energy use 25% to 70% lower than code. Although each building is a good energy performer, additional energy efficiency and on-site generation is required for these buildings to reach DOE's ZEB goal. At current levels of performance, the one-story buildings—Zion, BigHorn, and TTF—could accomplish the ZEB goal with PV systems that would fit within the building footprint. ZEBs are not feasible for the two-story buildings within their footprints unless their loads are reduced.
- **We can replicate the lessons learned from the case studies in the future generation of low-energy buildings.** Even though every commercial building is unique, the lessons learned from the case studies can be applied to a wide variety of commercial buildings. The buildings and their lessons learned define a set of best practices. This includes design elements that should be avoided in commercial buildings as well as elements that should be carried forward to additional buildings. Understanding success and opportunities in the current generation of low-energy buildings can improve the energy efficiency of all commercial buildings—the best practices should be applied to future buildings.

4.1.2 Lighting and daylighting systems

Lighting is the largest single end use in commercial buildings, at 30% of the total energy used. From a national perspective, the potential for daylighting savings is significant. Based the 1999 CBECS data set, nearly 80% of the total floor area in commercial buildings has an exterior ceiling or is within 15 ft (4.6 m) of an exterior wall and therefore has the potential to be daylight.

We believe daylighting is critical to creating low-energy buildings. Good daylighting can offer dramatic electric energy savings benefits. All six high-performance buildings use daylighting systems to offset electrical lighting energy use. Top-lit daylighting through clerestories and high windows are integral to each daylighting system. Daylighting is the best resource for total energy savings at Zion, Oberlin, BigHorn, and TTF. All six buildings feature daylighting design, and all have experienced problems. Some lacked the expected energy savings, experienced unacceptable glare, or had lower than anticipated lighting levels. Postoccupancy evaluations addressed some of these problems, increasing energy savings and occupant satisfaction.

Six elements were defined to achieve energy savings through daylighting. If five of the six elements necessary to good daylighting are done correctly, but one is not, energy savings may not result. A good daylighting design should result from an integrated design process. The daylighting system has to be integrated with the envelope and trade-offs with heating and cooling understood to maximize whole-building energy savings. Even with the good integrated design in each building, the following six elements of a daylighting system are needed to maximize daylighting savings.

- Design buildings to provide daylighting to all possible zones.
- Provide for glare mitigation techniques in the initial design.

- Provide automatic dimming daylighting controls for all daylit zones.
- Interior designs should compliment the daylighting.
- Integrate the electrical lights with the daylighting system.
- Commission and verify postoccupancy energy savings.

4.1.3 *Integrating the envelope and mechanical systems*

Energy use in commercial buildings is very diffuse. Some larger components are combined with many smaller end uses that add up to significant energy use at the whole building level. Therefore, there is no single technology or even a set of innovative technologies for realizing low-energy buildings. A diffuse set of solutions in the design and operation must be successfully applied and integrated. Low-energy buildings must be system engineered from a whole-building perspective to integrate the innovative technologies throughout the design process through occupancy and operation.

We learned the following lessons from working with the building envelopes and mechanical systems of the six case study buildings.

- **Use the envelope as the first method of creating low-energy buildings.** Engineer the envelope to reduce loads with features such as increased insulation, window tuning, and self-shading, and at the same time integrate passive solar heating, cooling, daylighting, and natural ventilation technologies. Then size HVAC equipment to meet the remaining loads. Use the mechanical system to make up for what cannot be accomplished by architectural form and envelope, not to correct for an architectural design that is climatically ill conceived.
- **Design the envelope to minimize thermal bridging.** An otherwise well-insulated envelope can be ineffective if a single component lacks appropriate thermal properties. Additional consideration is typically needed to ensure the doors are well insulated (especially those that experience direct solar gains), window frames are installed with thermal breaks, and the insulation at the interface with ground-coupled surfaces has been appropriately specified. Ensuring proper insulation details are included in the specifications and then implemented during construction is essential to achieving a thermally uniform envelope.
- **Consider Trombe walls and direct solar gains for passive heating.** We found Trombe walls to be an effective integrated envelope technology that can provide a significant portion of the heating needs. The annual net effect has to be considered when designing a Trombe wall, as the additional cooling loads can affect the cooling system performance. Properly designed direct solar gains can also provide space heating, if direct beam is acceptable. Zion, BigHorn, Oberlin, TTF, and Cambria are clearly heating dominated buildings. Passive solar heating has not been used often for commercial buildings because conventional wisdom indicates that such buildings are cooling dominated. However, low-energy commercial buildings tend to require more heating because of reduced internal and solar heat gains.
- **Natural ventilation can provide significant fan and air-conditioning energy savings.** Four of the buildings used natural ventilation for cooling and ventilation. The systems at Zion and BigHorn were mostly successful. They provided all the outdoor and cooling requirements (Zion's cooltowers are considered an evaporative cooling system driven by natural ventilation). Limited success was observed at CBF, as the system typically operated in hybrid mode, using exhaust fans. Minimal natural ventilation is used at Oberlin because of difficulties developing and implementing appropriate controls.
- **Use evaporative cooling systems in dry climates.** All cooling requirements were met with evaporative cooling systems in the dry climates of Zion and TTF. In a dry climate, two-stage (direct plus indirect) evaporative cooling can provide sufficient cooling capacity with less energy

use than refrigerant-based cooling systems. TTF uses a two-stage evaporative cooling system with a variable speed supply fan, and Zion uses a passive downdraft cooltower system that is functionally equivalent to direct evaporative cooling.

- **Consider electric resistance heating carefully.** Electric resistance heating can be used successfully in low-energy buildings, if it is used sparingly and does not cause excessive demand charges on the building. No ductwork or mechanical rooms are required with radiant panels, and radiant heat can be provided directly to where it is needed. Electric radiant heating panels worked at Zion because Trombe walls were a significant heating source, and demand-responsive controls ensured electric heating did not cause excessive peak demands. Heat pumps are often better for the primary heating system, with electric resistance as backup.
- **Use ERVs in conjunction with economizers and only when recovered energy is a net energy saving.** A properly controlled ERV can realize energy savings; the same ERV improperly controlled may actually increase energy use and cost. ERVs should not replace proper controls for the amount and scheduling of outdoor air, appropriate equipment sizing, or conventional economization cycles. Systems with ERVs and ground-source heat pumps suffered from the lack of an economizer. ERV recovery should be used when recovered energy is more than the fan energy for the unit and only when the recovered energy benefits the building. These outdoor air systems should also be incorporated with an economizer cycle.
- **Carefully size heat pumps and ground loops.** Ground-source heat pumps with ERVs are the primary heating and cooling sources at Oberlin, CBF, and Cambria; each heat pump system had performance issues related either to equipment or to ground capacity sizing. Part-load controls for groundwater loop pumps should be considered to save on pumping energy when capacity is not needed. Additional work is needed to understand the ground characteristics as it is believed wells are underperforming. Additional work is needed to control the systems to minimize pump energy. In some cases, ground temperatures were less favorable than outdoor air temperatures.
- **Design the control system to be fully integrated with the capabilities of equipment and building operators.** Innovative controls are often the critical glue for integrating a diffuse set of energy efficiency solutions, allowing a low-energy building to reach its potential. As each low-energy building is a prototype that includes state-of-the-shelf efficiency technologies, the lacking technologies are often in the whole-building control algorithms (software) required to ensure the building operates as a system.

4.1.4 Photovoltaic systems

For DOE's ZEB goal to become a reality, buildings will have to produce more energy than they use with PV systems on the roofs. Future ZEB will not only require efficient use of energy, but they will also need to maximize energy production. All systems produced less than expected because of performance degradation sources such as shading, parasitic losses, inverter faults, and lack of power-point tracking. Each system output was degraded because of balance of system component integration problems, operational problems, and shading. Combined, they reduced overall output 14% to 68%.

Our experience with PV systems in buildings taught us the following:

- **Design grid-connected PV systems to not have parasitic standby loads.** During nighttime hours when the Oberlin or Cambria PV system was in standby mode, the inverters and transformers consumed electricity. Nighttime parasitic PV system losses accounted for 7% to 37% of the total PV output depending on how often each system was in standby mode. An automatic circuit that disconnects the PV system from the grid when the PV system is down and reconnects when the PV system is operational should be implemented when isolation

transformers are used. This strategy applies for systems where loads are created by the PV system at night, usually a result of the choice of inverter.

- **Consider an automatic monitoring system for PV system operation.** Occupants and operators were often unaware of extended downtimes; this lack of awareness can result in even longer downtimes. When the system is down, it is not easily noticed as the grid power meets any building load. A simple method or monitoring technique that provides feedback to the owners and occupants about PV generation effectiveness or performance ratio would address the simple problem of inverter faults that require manual restarts. This fault, typically caused by system integration issues, has been a primary source of PV system downtime in the case studies.
- **PV panels should be located where they will not be shaded.** Each PV array experienced shading, resulting in a range of energy penalties from 2% to 44% output reduction. Sources of shade included trees, canyon walls, and the building structure.
- **Consider specifications for how a PV-based UPS system transitions to and from utility power.** The Zion PV/UPS system is a high-value feature, even though it displaces only a part of the total energy load. During daylight hours, the system can provide power for business operations without relying on power stored in the UPS system battery bank. Additionally, this central UPS system entirely eliminates the need for additional small UPS systems in the building—a source of additional plug loads because of their poor efficiency. However, the Zion UPS system has had some difficulties determining when to disconnect from and reconnect to the utility power. Future efforts to use PV systems for a building-wide UPS should carefully investigate how the equipment responds to the types of power failures the building is likely to experience.
- **Use maximum power-point tracking controllers.** An MPPT voltage controller would increase performance of the Zion PV system by 16% compared to the fixed operating voltage control of 53.6 VDC. The annual average AC Generation Effectiveness values were 3.27% for the BigHorn PV system without inverter faults and 3.92% for the same PV array and an MPPT inverter, which is a 20% annual improvement with the MPPT inverters over the use of fixed voltage inverters.
- **Integrate PV systems with demand-responsive controls and on-site thermal storage to maximize energy cost savings and payback.** The economic payback of PV systems depends on the net metering and interaction with demand charges. PV systems contribute very little to reducing building peak electrical demands. Therefore, the payback for the PV system is poor because it offsets only electricity energy charges, typically \$0.02–\$0.05/kWh. Additional demand reduction cost savings because of the PV system would increase the cost justification of the PV system. On-site storage systems such as ice storage, combined with demand-responsive EMS, will be required to realize the full economic value of the energy and power produced by PV systems in future ZEBs.

4.1.5 Peak demand and demand management

The easiest method to reduce energy cost in a commercial building is to reduce the peak demand charges. Electric demand charges can contribute to more than 50% of the total utility costs. An efficient building that uses very little energy could still have large demand charges with poor control.

The following lessons learned provide valuable insight into understanding peak demands in low-energy buildings:

- **Low-energy buildings do not have typical load shape profiles.** Peak demands in low-energy buildings are often occur at atypical times of the day. The conventional commercial building has summer peak demands in the late afternoon when cooling and lighting loads are the greatest. Well-daylit buildings reduce lighting and peak cooling loads, shifting peaks to atypical times. Low-energy buildings can shift when a peak demand is met, but they do not necessarily reduce

the overall peak demand. Evaporative cooling, reduced LPD, and HVAC equipment that have been downsized to meet reduced thermal loads are the best ways to guarantee peak demand reductions. Each of these techniques reduces peak demands because even if they are all on, the peak consumption is still less than the baseline equivalent. Technologies that depend on a solar resource such as daylighting, Trombe walls, PV systems, and natural ventilation are not always available to reduce energy use. Therefore, they cannot be relied on for peak demand reduction, unless controls are used to adjust building energy use to account for the solar availability.

- **PV systems have had limited success reducing peak demands.** The PV systems in this set of low-energy buildings have not significantly reduced the building demand. In these buildings, any small demand reduction caused by PV is from load diversity. Peak demands often occurred during atypical times that were not coincident with PV production, when daylighting was not available for demand reduction.
- **Demand-responsive controls can save energy costs and increase load factor.** The largest energy cost savings of all the buildings was at Zion because of aggressive demand management, which the other buildings did not use. The load factor was also consistently higher than the other buildings. Demand management combined with on-site storage (building mass) was the best use of on-site generation for reducing peak demands. Oberlin was the least successful at using PV for demand reduction because of high peak demands and a large PV system that reduced energy use but not peak demands, which resulted in low load factors.
- **Low-energy buildings can have low load factors.** Energy-efficient buildings strive to lower energy consumption; however, they often do not reduce the demand by the same amount. If the energy use is reduced more than the peak demand, the load factor decreases. A low load factor means that the utilities will have to supply less energy, but there is no reduction in capacity requirements. Therefore, the utilities still have to maintain the same capital structure: generation, transmission, and distribution capacities. Keeping power plants in spinning reserve while they wait for higher demands requires energy, so even though a building may reduce site energy consumption, the source energy consumption may not be reduced by the same amount. Even buildings with on-site electricity generation from PV systems rarely reduce demand by more than a few percent. Energy-efficient buildings should manage peak demand with demand-responsive controls and possibly on-site energy storage to ensure demand savings are in line with energy savings.

4.1.6 Plug and equipment loads

Minimize parasitic loads. A significant part of the equipment and plug loads in all these buildings consists of idle computers. Energy savings can be realized by turning equipment off or forcing it into “sleep mode” during periods of inactivity. Power management software should be installed on all computers. Flat screen monitors should also be used for added energy savings. Vending machines can be turned off during periods of inactivity. EnergyMisers save 30% to 50% in energy use and typically have a payback period of two years.

4.1.7 Postoccupancy evaluation techniques

The following lessons learned are derived from our experiences with applying POE processes:

- **Determine whole-building energy savings with as-built and base-case model comparisons.** Ideally, the base-case site energy use, source energy use, and energy costs should be compared to an as-built model to calculate savings for a typical weather year. Energy savings uncertainties can be minimized when savings are determined from the comparison of one simulation to another simulation (e.g., base case to as-built). Because difficult-to-know inputs are held the same in both simulations, such comparisons remove much of the uncertainty inherent in an hourly

building energy simulation. Variables that change throughout the year, such as inconsistent occupancy, set-point changes, and equipment performance degradation are difficult to account for in an annual building energy simulation. By comparing a base-case model to an as-built model with the same schedules, the uncertainty caused by these inconsistent variables is reduced.

- **Modeling tools that can simulate baseline and as-built low-energy buildings should be used to ensure consistent evaluation techniques.** To perform complete POEs, a whole-building simulation tool should be used that can adequately model all features and operations in an integrated manner, including subhourly energy use, innovative HVAC and control systems, site utility costs, and on-site production. A common limitation of the simulation tools was calculating energy costs. This problem was most evident when we tried to assess the impact of PV. To fully realize the cost implications in commercial buildings, PV must be integrated into the simulation engine to fully determine demand savings potential.
- **Measure performance against design goals.** Energy savings depend on how savings are defined. A complete high-performance building should result in significant energy savings in the following metrics: site energy savings, source energy savings, and energy cost savings. A building can excel in the energy performance indices most important to the building owners, but fall short or exaggerate other performance indices. Oberlin performed well in site savings, realized minimal energy cost savings, and excelled in source savings (mostly because of PV production and benchmarking techniques). A building energy performance evaluation should focus on the metric the building was designed to optimize, but it should also consider other significant performance indices. If the team sets energy cost savings goals during design, verifying these design goals during actual operation may be difficult because energy prices may change. Site or source energy savings goals are easier to measure and typically less susceptible than energy cost savings to external fluctuations such as energy prices.
- **Use performance metrics procedures to standardize measurement and reporting for POEs.** The commercial building industry needs to develop standardized and repeatable whole-building POE techniques. As more commercial buildings are designed to be “green,” the industry will need to validate real-world energy savings. An integral part of a standardized POE is a commercial buildings benchmark.
- **Use dedicated, self-contained data acquisition equipment to monitoring energy performance.** Performance monitoring systems need to be robust and maintained by someone locally or monitored remotely, with someone local to handle problems. Personal computers should not be exclusively relied upon for data retrieval and archiving, as they are unreliable compared to systems dedicated to data logging. A dedicated DAS for monitoring energy performance can provide 99% data availability over a two-year monitoring period. A complete energy balance on metering is essential to find faults in monitoring. Missing data can be minimized with error checking routines and reasonable data filling techniques. Fifteen-minute data logging is appropriate for a wide-range of evaluations. In cases where equipment issues were found (such as a five-minute PV inverter cutout), data sets that are more detailed were collected for limited periods.
- **The current methods for calculating electricity source energy use are too general.** Additional work is needed to account for hourly, daily, and regional variations in electricity generation heat rates and supply mix. Regional time-dependent valuations for determining time-of-use source energy are needed throughout the country to account for variations in when and where energy is used.

4.2 Best Practices for High-Performance Buildings

Much can be learned from these case studies. Each of these six commercial buildings has its unique purpose and function, and all have commonalities. All must stand up to climatic conditions, and all must provide acceptable comfort for the occupants. All are successful in these respects, and all are good energy performers. All had owners who pushed low-energy goals and considered energy efficiency as part of the decision-making process. The architects and engineers then met and implemented the vision. This vision required an integrated design process to achieve the goals. All the buildings use innovative energy technologies to reduce their energy use.

We captured a set of best practices that result from the lessons learned from these six buildings. Best practices are not lessons learned; rather, the best practices are derived from the lessons learned. Best practices are proven real-world technologies and processes that lead to high-performance buildings. This list is the result of our research experience with the six case study buildings—this is not an attempt to create an exhaustive list.

The following best practices should be applied to future low- and zero-energy buildings:

1. **Use a whole-building design process to design, construct, and operate future low-energy buildings.** This includes:
 - a. Set a specific, quantifiable energy design goal that is used to guide the design process and can be verified during operation.
 - b. Include everyone involved in the project at the earliest stages of the design process.
 - c. Use whole building simulation tools to determine the energy performance of the building at all stages of design, construction, and occupancy. The whole-building design process is a simulation-based, quantitative, and qualitative method to help architects and engineers create low-energy buildings. Low-energy design is not intuitive. The energy use and energy cost of a building depend on the complex interaction of many parameters and variables. The problem is far too complex for “rules of thumb” or hand calculations. The interactions are best studied with computerized energy simulation software to thoroughly evaluate all interactions between the building envelope, HVAC system, and design features.
 - d. Design the building envelope such that it can be used to meet as many of the loads as possible. The envelope should be the first method of creating low-energy buildings; the mechanical and lighting systems should then be sized to meet any remaining loads. Low-energy architecture is not effective if mechanical systems have to solve problems from the architectural design.
 - f. Update the design simulations from predesign through occupancy to ensure the design simulations will measure up to actual performance.
2. **Plan for an energy performance POE.** A POE includes disaggregating the energy use of major end use categories. The best time to ensure ease of end use monitoring is in the design and construction phase, when like loads can be arranged together in the wiring panels. Providing for a POE also allows evaluators access to the energy management system to develop and test innovative control strategies. Commissioning a new building is essential, but it ensures only that the building components operate as specified. All six case studies were commissioned either formally or informally. In general, the traditional commissioning did not necessarily translate to expected energy performance or verify low-energy design goals. Continual monitoring of the performance during the POE, or continuous system commissioning with key performance metrics is important to ensure that the goals of the design are met under normal operating conditions. In all the buildings, adjustments were made to better align the performance with the design goals. In addition, feedback on actual performance to the engineers and architects is important for improving future designs.

3. **Implementing measurement procedures such as those developed in DOE's Performance Metrics Research Project.** Obtaining reliable metrics for determining a building's performance is one of the core challenges to achieving widespread adoption of high-performance buildings. Currently available procedures for determining performance metrics are available in the following documents:
 - a. *Procedure for Measuring and Reporting Commercial Building Energy Performance*
 - b. *Procedure to Measure Indoor Lighting Energy Performance*
 - c. *Procedure for Measuring and Reporting the Performance of Photovoltaic Systems in Buildings*
 - d. *Procedure for Developing a Baseline Simulation Model for a Minimally Code-Compliant Commercial Building*
 - e. *Standard Definitions of Building Geometry for Energy Evaluation Purposes*
 - f. *Procedure to Determine Source Energy and Emissions for Energy Use in Buildings.*(See Section 3.7.5 for details and references of these procedures.)
4. **Integrate daylighting into the envelope and lighting systems.** Controlling the electric lighting when daylighting is available works in all climates and in almost any type of building. A good daylighting design should result from an integrated design process. The daylighting system has to be integrated with the envelope and trade-offs with heating and cooling understood to maximize whole-building energy savings. Use the following best practices to integrate daylighting with the lighting systems:
 - a. **Design daylighting into all occupied zones adjacent to an exterior wall or ceiling.** Design daylighting systems into all occupied spaces in a one-story building. In multistory buildings, daylighting should be designed into all occupied spaces on the top floor and all other zones adjacent to exterior walls. Typically, all zones within 15 ft (4.6 m) of an exterior wall can use perimeter daylighting to reduce lighting loads. Greater daylighting penetration depths can be achieved with architectural elements such as light shelves or other devices that reflect light onto ceilings. Sufficient daylighting can be achieved with relatively small aperture areas. Making openings larger than needed for daylighting is counterproductive, especially in locations where cooling loads dominate. Daylight modeling and whole-building energy simulation tools are recommended for proper design of daylighting systems.
 - b. **Provide for integral glare mitigation techniques in the initial design.** Techniques such as diffusing glass, light-deflecting panels, full shading overhangs, and light shelves that do not require occupant interaction for glare mitigation should be considered for all south-facing clerestories. Other daylighting techniques such as north-facing clerestories and tubular daylighting devices that do not have direct solar-beam components should also be considered
 - c. **Provide automatic, continuously dimming, daylighting controls for all daylit zones.** For all daylit zones that have a daylighting contribution, continuously dimming controls should be used to maximize daylighting savings. Occupants cannot be relied on to control the lights in response to available daylight. Automatic controls that dim and energize lighting circuits according to available daylight are typically better than stepped controls. Dimmers should be specified that are fairly linear in the relationship of light output to energy use. When a manual override for automatic daylighting controls is needed, a maximum illuminance set point should be included in the manual control strategy. This control sequence will ensure that even when the lights are manually controlled to be on, daylighting can still offset lighting energy use. Occupancy sensors should be used to disable the manual override when the zone is unoccupied. On/off daylighting controls are acceptable for hallways, restrooms, and areas where constant lighting levels are not critical.

- d. **Design interiors to maximize daylighting distribution.** Install highly reflective nonspecular finishes in all daylit zones, especially when indirect lighting is used. Dark ceilings and structural elements are common reasons for poor daylighting distribution and reduced savings. Anticipate for how occupants, furniture, and other features such as light absorbing merchandise and shelving in retail spaces, window frames, actuators, mullions, and screening will reduce daylighting aperture, transmittance, and distribution.
 - e. **Integrate the electric lights with the daylighting system.** Design the daylighting system to exceed the recommended light levels, such occupants do not notice when the electric lighting is off. The rows of electrical lighting fixtures (and circuits) should run parallel to the daylighting fenestration. Each circuit should be controlled separately so that they can be dimmed as necessary in response to the daylight levels that vary with distance from the fenestration. Use uplighting sparingly in daylit spaces with high ceilings and not at all with high dark ceilings. Lower LPDs are possible in daylit buildings if task lighting is provided at the critical work surfaces. The electric lighting design should use lower LPDs for night use and should account for the contrast between the dark exterior and interior environment. This implies that reduced lighting levels are adequate at night, compared to the day. Appropriate placement and use of occupant-controlled task lighting is essential for daylit buildings with reduced LPDs, especially for detailed task work.
 - f. **Commission and verify postoccupancy energy savings.** Commissioning a daylighting system that consists of adjusting photosensors and ensuring proper sensor placement is required so the electric lighting system responds properly to daylight. Verifying lighting energy savings according to NREL's lighting measurement procedure (Deru et al. 2005) is a good method to determine whether all six elements have been successfully implemented. Postoccupancy daylighting evaluations in all six case studies resulted in changes to the daylighting systems, which addressed occupant complaints and increased daylighting savings.
5. **Use economizers in conjunction with ERVs.** The control and systems integration of economizers, natural ventilation, and ERVs needs to be very carefully designed and implemented. Natural ventilation or ERVs, as implemented in the buildings we studied, were not as good as the conventional economizer cycle they replaced. Systems with ERVs and ground-source heat pumps should have economizers for when conditions warrant. ERVs should be operated when recovered energy is a net saving to the building. In addition, ERVs should be used only when needed, as part of a demand-responsive ventilation system.
 6. **Use evaporative cooling systems in dry climates.** All cooling requirements in dry climates can be met with evaporative cooling systems. If more thermal and latent control is needed, evaporative cooling can be used as a first stage of cooling.
 7. **Design natural ventilation systems with the following best practices:**
 - a. **Design natural ventilation to rely primarily on stack effect unless wind direction and speeds are reliable.** Even with reliable winds, passive cross-ventilation should be engineered for a variety of airflow pathways and wind directions.
 - b. **Separate natural ventilation supply and relief from the fenestration and use relief dampers for the passive ventilation.** Use dampers with typical HVAC control actuators to reduce maintenance and integration issues. Motorized window actuators are prone to failure and are difficult to interface with the controls system. Furthermore, operable windows do not fully open and window screens reduce the effective opening, limiting both daylighting and natural ventilation.
 - c. **Use automatic supply and relief controls that do not rely on occupant interaction.** The case studies showed that occupants cannot be relied on to operate the manual windows.

Failure of the occupants to control windows properly can cause the HVAC system to operate when the windows are open.

- d. **Minimize the use of enclosed spaces.** Carefully design interior partitions, floor plan, and fenestration to promote good circulation of naturally induced airflow. Enclosed spaces tend to overheat because naturally induced low-pressure ventilation has difficulties providing sufficient airflow.
 - e. **Do not use natural ventilation systems as replacements for conventional economizers.** One way to think about passive natural ventilation is that it essentially economizes without fans. If it is fan assisted, it is much like running an economizer. However, from a thermal comfort point of view, it is limited to moderate temperatures. An economizer-based system can control supply air temperature through mixing to provide more uniform thermal comfort for a wider range of outdoor temperature and humidity, especially in buildings with high internal gains.
8. **Use demand-responsive controls that integrate on-site energy production, energy storage, and daylighting to reduce peak demand charges and increase load factors.** An efficient building that uses very little energy could still have large demand charges. Load factors in the current generation of low-energy buildings are often lower than typical buildings because of a disproportionate ratio of average energy use to peak demand. Load factors are low primarily because PV systems reduce energy use, but may not reduce peak demands. Demand-responsive strategies that integrate on-site generation with the thermal capacity of the building require advanced controls that allow the temperature of the building to float based on instantaneous consumption and production. Using PV generation with demand-responsive controls to further reduce peak demands is typically the most cost-effective use of this resource.
 9. **Minimize parasitic loads.** A significant fraction of the equipment and plug loads in all these buildings is made up of idle computers. Energy savings can be realized by making the machines EnergyStar enabled to shut them down during periods of inactivity. Power management software should be installed on all computers. Flat screen monitors should also be used for added energy savings. Vending machines should be turned off during unoccupied hours.

4.3 Recommended Future Research

To help DOE reach its ZEB goal by 2025 and to continue to help owners and design teams realize high-performance buildings, we recommend the following based on our experience with the six case study buildings:

1. **Standardized methods should be used to collect data and determine energy savings to report building performance.** There is currently no industry standard for reporting building energy savings in the built environment. A POE should include calculating site energy, source energy, and energy cost savings in a consistent and repeatable manner. An important part of a standardized energy savings calculation method is the comparison benchmark. Standard benchmark buildings need to be developed to identify consistent starting points and performance metrics. A standardized method, similar to that used for the residential program (Building America) should be used to create a fixed minimally code-compliant building. These methods will form a starting point for evaluating energy performance that does not change as energy efficiency standards become more stringent.
2. **For future research efforts, start with the lessons learned from the six case studies.** We do not need to relearn these lessons. Future test buildings should use the best practices developed as part of these case studies as a starting point. Additional test buildings should focus on showing the industry that we can construct and operate commercial ZEB. Future case studies may identify additional best practices.

3. **Include an element in future ZEB research efforts to focus on building owners and developers.** Future ZEB research is needed to move the ZEB concept forward from prototype to market adoption. Future work should contain an element that is directed toward building owners, as they have had the greatest influence on producing the current generation of low-energy buildings.
4. **Develop integrated HVAC equipment, system, and control packages.** The weak point in integrating the HVAC system in the case studies was the control system. Innovative systems often require integrated controls to realize energy savings. Controls problems were primarily software and algorithm related, and not hardware related. Each HVAC system is a unique application that requires specialized controls to integrate each component to realize energy savings. Detailed POEs identified EMS reprogramming needs for each case. Integrated HVAC packages designed for energy savings could remove the prototype application in future ZEBs. An integrated HVAC system design package could also reduce the need for detailed postoccupancy tuneups to realize savings.
5. **Develop integrated whole-building lighting system packages.** The best method to ensure the electrical lighting system is integrated with the daylighting is to develop lighting system packages. These design packages would provide a system-engineered envelope and daylighting design, glare mitigation practices, interior designs, electrical lighting design, and the controls necessary to ensure the lights turn off when sufficient daylighting is available.
6. **Use simulation tools to develop technology option sets.** Optimization research and tools are needed to develop technology option sets that provide robust support information to help designers make good decisions that affect energy performance. Within the goal of increasing the market penetration of high-performance buildings, technology option sets are envisioned as a means of improving the convergence of building energy analysis tools and the building design process. Optimization based on pre-defined options has the potential to provide more useful results, and at the same time, be more accessible to the building design team. Technology option sets should consist of specific guidance on optimal combinations of energy design measures for fabric and equipment and be determined by using optimization methods on building models that include the program and form details available during design development.
7. **Develop regional time-dependent valuations for a time-of-day source electricity conversion rate throughout the country.** Additional work is needed to account for hourly, daily, and regional variations in electricity generation heat rates and supply mix. The current methods for calculating source energy use are too general. TDVs were developed by the California Energy Commission to determine the hourly value of delivered energy in California (CEC 2005). Regional TDVs are needed to accurately calculate source energy use and savings throughout the country to provide a more accurate way to credit the value of energy savings than traditional flat valuation methods because they account for variations in source energy conversion rates related to time of day, seasons, geography, and fuel type. Buildings designed under TDVs will be more economical for building owners because they will consume less energy during peak conditions and reduce the need for additional power plants and distribution systems.
8. **Investigate methods to further increase the energy efficiency of equipment and plug loads.** Equipment and plug loads continue to grow in absolute energy use and become a greater piece of overall building energy use as efficient HVAC&L systems become more prevalent. A particular concern is parasitic loads that use energy during standby or off modes. Future work in this area is needed to understand the energy penalty of each plug load that includes an AC-to-DC conversion device and potential solutions for limiting energy use when equipment is not needed. Potential energy savings technologies such as switching transformers or a DC plug load electrical infrastructure that leverages on-site DC generation should be investigated. In addition, as these

loads were often underestimated in the design, future efforts should focus on improving the accuracy of the equipment and plug load assumptions made during the design phase.

9. **Evaluate the technical viability of and marketability of key successful strategies for wide-scale deployment.** Technologies such as cooltowers, natural ventilation, and daylighting should be investigated further to determine optimal design solutions and appropriate applications. There is a need in the design community to identify better designs and controls for natural ventilation systems. We need to identify the research and development needs to facilitate the wide-scale deployment of daylighting, as the technology and controls have improved to the point where almost 80% of the commercial floor area could be daylighted. As more buildings produce energy from PV, the grid implications of large amounts of exported PV energy must be investigated. This evaluation would also include developing better methods to evaluate each technology and the energy savings potential.
10. **Study the degradation of long-term, whole-building energy performance.** Determine how low-energy buildings perform over time and investigate how continuous commissioning and operator education can ensure continued energy savings over the long-term operation of a low-energy building. Identify technologies that suffer from performance degradation over time. For example, this could include understanding the long-term capacity of the ground wells in the ground-source heat pump systems. This study should also include maintainability of the systems.
11. **Study the ability of PV systems to minimize demand with controls.** Further analysis of the potential value added by demand-responsive controls integrated with on-site generation is needed to understand the best use of excess PV energy production. This work could include developing peak demand-shifting algorithms for minimizing electrical cost to fully benefit from energy efficiency devices (especially daylighting) and on-site generation capacity. These algorithms could be researched with the planned releases of EnergyPlus that will have the capability to model demand-responsive controls integrated with thermal storage, daylighting, and PV systems on a 15-minute time step. As more buildings have PV production, it is also necessary to understand the grid implications of large amounts of exported PV energy.

5 REFERENCES

- ARI. (2003). *ARI Standard 330*. www.ari.org/std/standards.html. American Refrigeration Institute, Virginia. Last accessed October 2004.
- ASHRAE. (1989). *ANSI/ASHRAE/IESNA Standard 90.1-1989 Energy Standard for Buildings Except Low-Rise Residential*. Atlanta, GA: American Society of Heating, Refrigerating and Air-Conditioning Engineers.
- ASHRAE. (1999). *ANSI/ASHRAE/IESNA Standard 90.1-1999 Energy Standard for Buildings Except Low-Rise Residential*. Atlanta, GA: American Society of Heating, Refrigerating and Air-Conditioning Engineers.
- ASHRAE. (2001). *ANSI/ASHRAE/IESNA Standard 90.1-2001 Energy Standard for Buildings Except Low-Rise Residential*. Atlanta, GA: American Society of Heating, Refrigerating and Air-Conditioning Engineers.
- ASHRAE. (2004). *ANSI/ASHRAE/IESNA Standard 90.1-2004 Energy Standard for Buildings Except Low-Rise Residential*. Atlanta, GA: American Society of Heating, Refrigerating and Air-Conditioning Engineers.
- ASHRAE. (2005). *2005 ASHRAE Handbook of Fundamentals*. Atlanta, GA: American Society of Heating, Refrigerating and Air-Conditioning Engineers.
- Atif, M.R.; Love, J.A.; and Littlefair, P. (1997). *Daylighting Monitoring Protocols and Procedures for Buildings. A Report of IEA Task 21/Annex 29 Daylight in Buildings*. T21/D2.1/97-01. Ottawa, Ontario, Canada: Institute for Research in Construction.
- Barley, C.D.; Deru, M.; Pless, S.; Torcellini, P. (2005). *Procedure for Measuring and Reporting Commercial Building Energy Performance*. www.nrel.gov/docs/fy06osti/38601.pdf. Technical Report NREL/TP-550-38601. Golden, CO: National Renewable Energy Laboratory, 102 pp.
- Branco, G., Lachal, B.; Gallinelli, P.; Weber, W. (2004). *Predicted versus Observed Heat Consumption of a Low Energy Multifamily Complex in Switzerland Based on Long-Term Experimental Data*. *Energy and Buildings*, Vol. 36, Issue 6, pp. 543–555.
- CEC (2005). *Time Dependent Valuation (TDV) Economics Methodology*. www.energy.ca.gov/title24/2005standards/archive/rulemaking/documents/tdv/. Sacramento, CA: California Energy Commission.
- City of Boulder. (2006). *Solar Access Guide, Building Services Center, Boulder, Colorado* <http://joomla.ci.boulder.co.us/files/PDS/codes/solrshad.pdf>, last accessed May 2006.
- Deru, M.; Blair, N.; Torcellini, P. (2005b). *Procedure to Measure Indoor Lighting Energy Performance*. Technical Report NREL/TP-550-38602. www.nrel.gov/docs/fy06osti/38602.pdf. Golden, CO: National Renewable Energy Laboratory, 72 pp.
- Deru, M.; Kirkpatrick, A. (2001). *Ground-Coupled Heat and Moisture Transfer from Buildings Part 2: Application: Preprint*. www.nrel.gov/docs/fy01osti/29694.pdf. Conference Report NREL/CP-550-29694. Presented at the American Solar Energy Society (ASES) National Solar Conferences Forum 2001 in Washington, D.C., April 21–25, 2001. Also published in the *Journal of Solar Energy Engineering*, ASME, Vol. 124, No. 1, pp. 17–21, 2002. Golden, CO: National Renewable Energy Laboratory.
- Deru, M.; Torcellini, P. (2006). *Procedure to Determine Source Energy and Emissions for Energy Use in Buildings*. Technical Report NREL/TP-550-38617. Golden, CO: National Renewable Energy Laboratory. Unpublished draft: expected publication date May 2006.
- Deru, M.; Torcellini, P. (2005). *Standard Definitions of Building Geometry for Energy Evaluation Purposes*. <http://www.nrel.gov/docs/fy06osti/38600.pdf>. Technical Report NREL/TP-550-38600. Golden, CO: National Renewable Energy Laboratory.

- Deru, M.; Torcellini, P. (2004). *Improving Sustainability of Buildings Through a Performance-Based Design Approach: Preprint*. www.nrel.gov/docs/fy04osti/36276.pdf. Conference Report NREL/CP-550-36276. Presented at the World Renewable Energy Congress VIII, Denver, CO, August 29–September 3, 2004. Golden, CO: National Renewable Energy Laboratory, 8 pp.
- Deru, M.; Torcellini, P.; Ault, R.; Bottom, K. (June 2003). *Analysis of NREL Cold-Drink Vending Machines for Energy Savings*. <http://www.nrel.gov/docs/fy03osti/34008.pdf> NREL Report No. TP-550-34008. Golden, CO: National Renewable Energy Laboratory, 20 pp.
- Deru, M.; Torcellini, P.; Pless, S. (2005). *Energy Design and Performance Analysis of the BigHorn Home Improvement Center*. www.nrel.gov/docs/fy05osti/34930.pdf. Technical Report NREL/TP-550-34930. Golden, CO: National Renewable Energy Laboratory, 120 pp.
- Deru, M.; Torcellini, P.; Sheffer, M.; Lau, A. (2005). *Analysis of the Design and Energy Performance of the Pennsylvania Department of Environmental Protection Cambria Office Building*. www.nrel.gov/docs/fy05osti/34931.pdf. Technical Report NREL/TP-550-34931. Golden, CO: National Renewable Energy Laboratory, 85 pp.
- DOE. (1995). *Code of Federal Regulations 10 – Energy*. Washington, DC: Office of the Federal Register, National Archives and Records Administration.
- DOE. (2005). *2005 Buildings Energy Databook*. buildingsdatabook.eren.doe.gov/. Washington, DC: U.S. Department of Energy.
- EIA. (2005). *Annual Energy Review 2004*. www.eia.doe.gov/emeu/aer/contents.html. Washington, DC: U.S. Department of Energy, Energy Information Administration.
- EIA. (2005a). *Commercial Buildings Energy Consumption Survey: Consumption and Expenditures Tables*. <http://www.eia.doe.gov/emeu/cbecs/> Washington, DC: U.S. Department of Energy, Energy Information Agency.
- EnergyPlus. (2005). *EnergyPlus User's Manual, V1.2.3*; December 2005. Engineering Document. Washington, DC: U.S. Department of Energy. www.energyplus.gov/. Last accessed April 2006.
- Fisk, W.; Faulkner, D.; Sullivan, D.; Chao, C.; Wan, M. P.; Zagreus, L.; Webster, T. (2004). *Performance of Underfloor Air Distribution: Results of a Field Study*. LBNL-56257. Berkeley, CA: Lawrence Berkeley National Laboratory.
- Griffith, B.; Deru, M.; Torcellini, P.; Ellis, P. (2005). *Analysis of the Energy Performance of the Chesapeake Bay Foundation's Philip Merrill Environmental Center*. www.nrel.gov/docs/fy05osti/34830.pdf. Technical Report NREL/TP-550-34830. Golden, CO: National Renewable Energy Laboratory, 145 pp.
- Hitchcock, R. (2003). *Standardized Building Performance Metrics – Final Report*. LBNL No. 53072. California Energy Commission, Public Interest Energy Program. Berkeley, CA: Lawrence Berkeley National Laboratory.
- IEA. (2002). Multi-Criteria Decision Making MCDM-23, International Energy Agency – Solar Heating and Cooling Programme, Task 23, Subtask C. www.iea-shc.org/task23/. Last accessed May 2004.
- IESNA. (2000). *The IESNA Lighting Handbook: Reference & Application*, ninth edition. New York, NY: Illuminating Engineering Society of North America.
- iiSBE. (2000). Green Building Tool. www.greenbuilding.ca/gbc2k/gbc-start.htm. Last accessed September 2005.
- Kavanaugh, S. P.; Rafferty, K. (1997). *Ground Source Heat Pumps*. Atlanta, GA: American Society of Heating, Refrigerating and Air-Conditioning Engineers.

- Mermoud, A. (1996). *PVSYST Version 3.3. User's Manual*. Geneva, Switzerland: University of Geneva, University Center for the Study of Energy Problems. www.pvsyst.com/. Last accessed September 2005.
- NIBS. (2006). *Whole Building Design Guide*. National Institute of Building Sciences. www.wbdg.org. Last accessed April 2006.
- Norford, L. K.; Socolow, R. H.; Hsieh, E. S.; Spadaro, G. V. (1994). *Two-to-One Discrepancy between Measured and Predicted Performance of a Low-Energy Office Building: Insights from a Reconciliation Based on the DOE-2 Model*. *Energy and Buildings* Vol. 21 (2), pp. 121–131.
- Pless, S.; Deru, M.; Torcellini, P. (2006). *Procedure for Developing a Baseline Simulation Model for a Minimally Code Compliant Commercial Building*. Technical Report NREL/TP-550-38604. Golden, CO: National Renewable Energy Laboratory. Unpublished draft: expected publication date July 2006.
- Pless, S.; Deru, M.; Torcellini, P.; Hayter, S. (2005). *Procedure for Measuring and Reporting the Performance of Photovoltaic Systems in Buildings*. www.nrel.gov/docs/fy06osti/38603.pdf. Technical Report NREL/TP-550-38603. Golden, CO: National Renewable Energy Laboratory.
- Pless, S.; Torcellini, P. (2005). *Energy Performance Evaluation of a Low-Energy Academic Building—Adam Joseph Lewis Center for Environmental Studies, Oberlin College, Oberlin, Ohio*. www.nrel.gov/docs/fy05osti/33180.pdf. Technical Report NREL/TP-550-33180. Golden, CO: National Renewable Energy Laboratory, 150 pp.
- SA. (1993). Specification Sheet for Stage II Indirect/Direct Evaporative Cooling Module. Canutillo, TX: SPEC-AIR.
- Stein, J.; Reiss, R. (2004). *Ensuring the Sustainability of Sustainable Design*. Boulder, CO: Platts Research and Consulting.
- Subbarao, K.; Burch, J.D.; Balcomb, J.D.; Hancock, C.; Lekov, A. "Short-Term Energy Monitoring, STEM-1.1 User Manual", SERI, TR-254-3613, December, 1989.
- Torcellini, P.A.; Hayter, S.J.; Judkoff, R. (1999). *Low-Energy Building Design—the Process and a Case Study*. NREL Report No. 26144. ASHRAE Transactions, V 105, Part 2, 1999, pp. 802-810. Golden, CO: National Renewable Energy Laboratory.
- Torcellini, P.; Long, N.; Pless, S.; Judkoff, R. (2005a). *Evaluation of the Low-Energy Design and Energy Performance of the Zion National Park Visitor Center*. www.nrel.gov/docs/fy05osti/34607.pdf. Technical Report NREL/TP-550-34607. Golden, CO: National Renewable Energy Laboratory, 156 pp.
- Torcellini, P.; Pless, S. (2004). *Trombe Walls in Low-Energy Buildings: Practical Experiences*; Preprint. www.nrel.gov/docs/fy04osti/36277.pdf. Conference Report NREL/CP-550-36277. Presented at the World Renewable Energy Congress VIII, Denver, CO, August 29–September 3, 2004. Golden, CO: National Renewable Energy Laboratory, 8 pp.
- Torcellini, P.; Pless, S.; Griffith, B.; Judkoff, R. (2005b). *Evaluation of the Energy Performance and Design Process of the Thermal Test Facility at the National Renewable Energy Laboratory*. www.nrel.gov/docs/fy05osti/34832.pdf. Technical Report NREL/TP-550-34832. Golden, CO: National Renewable Energy Laboratory, 144 pp.
- Torcellini, P.; Long, N.; Judkoff, R. (2003). *Consumptive Water Use for U.S. Power Production*. www.nrel.gov/docs/fy04osti/35190.pdf. Conference Report NREL/CP-550-35190. Presented at the ASHRAE Winter Meeting, Anaheim, California, January 24–28, 2004, Paper #4677. Golden, CO: National Renewable Energy Laboratory, 11 pp.
- USGBC. (2004). Leadership in Energy & Environmental Design Version 1.0. United States Green Building Council. www.usgbc.org. Last accessed September 2005.

APPENDIX A: ZERO-ENERGY BUILDINGS: DEFINITIONS AND ANALYSIS

In concept, a net zero energy building (ZEB) is a building with greatly reduced energy needs through efficiency gains such that the balance of the energy needs can be supplied by renewable technologies. Despite our use of the phrase “zero energy,” we lack a common definition—or a common understanding—of what it means. In this appendix, we use our sample of current generation low-energy buildings to explore the concept of zero energy—what it means, why a clear and measurable definition is needed, and how we have progressed toward the ZEB goal.

Using ZEB design goals takes us out of designing low-energy buildings with some percent energy savings goal into the realm of a sustainable energy endpoint. The goals that are set and how those goals are defined are critical to the design process. The definition of the goal will influence designers who strive to meet it (Deru and Torcellini 2004). Because design goals are so important to achieving high-performance buildings, the way a ZEB goal is defined is crucial to understanding the combination of applicable efficiency measures and renewable energy supply options.

A.1 Boundary Definitions and Energy Flows

At the heart of the ZEB concept is the idea that buildings can meet all their energy requirements from low-cost, locally available, nonpolluting renewable sources. At the strictest level, a ZEB generates enough energy annually to equal or exceed its annual energy use. The following concepts and assumptions have been established to help guide definitions for ZEBs:

A.1.1 Grid connection is allowed and necessary for energy balances

A ZEB typically uses traditional energy sources such as the electric and natural gas utilities when on-site generation does not meet the loads. When the on-site generation is greater than the building’s loads, excess electricity is exported to the utility grid. By using the grid to account for the energy balance, excess production can offset later energy use. Achieving a ZEB without the grid would be very difficult, as the current generation of storage technologies is limited. Despite the electric energy independence of off-grid buildings, they usually rely on outside energy sources such as propane (and other fuels) for cooking, space heating, water heating, and backup generators. Off-grid buildings cannot feed their excess energy production back onto the grid to offset other energy uses. As a result, the energy production from renewable resources must be oversized. In many cases (especially during the summer), excess generated energy cannot be used.

We assume that excess on-site generation can always be sent to the grid. However, in high market penetration scenarios, the grid may not always need the excess energy. In this scenario, on-site energy storage would become necessary.

A.1.2 Prioritize supply-side technologies to those available on site and within the footprint

Various supply-side renewable energy technologies are available for ZEBs. Typical examples of technologies available today include PV, solar hot water, wind, hydroelectric, and biofuels. All these renewable sources are favorable over conventional energy sources such as coal and natural gas; however, we have developed a ranking of renewable energy sources in the ZEB context. Table A-1 shows this ranking in order of preferred application. The principles we have applied to develop this ranking are based on technologies that:

- Minimize overall environmental impact by encouraging energy-efficient building designs and reducing transportation and conversion losses.
- Will be available over the lifetime of the building.
- Are widely available and have high replication potential for future ZEBs.

Table A-1 ZEB Renewable Energy Supply Option Hierarchy

Option Number	ZEB Supply-Side Options	Examples
0	Reduce site energy use through low-energy building technologies	Daylighting, high-efficiency HVAC equipment, natural ventilation, evaporative cooling, etc.
On-Site Options		
1	Use renewable energy sources available within the building's footprint	PV, solar hot water, and wind located on the building.
2	Use renewable energy sources available at the site	PV, solar hot water, low-impact hydro, and wind located on-site, but not on the building.
Off-Site Options		
3	Use renewable energy sources available off site to generate energy on-site	Biomass, wood pellets, ethanol, or biodiesel that can be imported from off site, or waste streams from on-site processes that can be used on-site to generate electricity and heat.
4	Purchase off-site renewable energy sources	Utility-based wind, PV, emissions credits, or other "green" purchasing options. Hydroelectric is sometimes considered.

This hierarchy is weighted toward renewable technologies that are available within the building footprint and at the site. Rooftop PV and solar water heating are the most applicable supply-side technologies for widespread application of ZEBs. Other supply-side technologies such as parking lot-based wind or PV systems may be available for limited applications. It can be argued that renewable energy resources from outside the boundary of the building site could also be used to achieve a ZEB. While this approach may achieve a building with net zero energy consumption, it is not the same as one that generates the energy on site and should be classified as such. We will use the term "off-site ZEB" for those buildings that use renewable energy from sources outside the boundaries of the building site.

A good ZEB definition should first encourage energy efficiency, and then use renewable energy sources available on site. A building that buys all of its energy from a wind farm or other central location has little incentive to reduce building loads, which is why we refer to this as an off-site ZEB. Efficiency measures or energy conversion devices such as daylighting or combined heat and power devices cannot be considered on-site production in the ZEB context. Fuel cells and microturbines do not generate energy; rather they typically transform purchased fossil fuels into heat and electricity. Passive solar heating and daylighting are demand-side technologies and are considered efficiency measures. Energy efficiency is usually available for the life of the building; however, efficiency measures must have good persistence and should be "checked" to make sure they continue to save energy. It is almost always easier to save energy than to produce energy.

Determining a project's boundary, which can be substantially larger than the building footprint, is an important part of defining on-site generation sources. The question arises as to whether this larger area should be considered for on-site renewable energy production. Typically, the only area available for on-site energy production that a building has guaranteed as "its own" over its lifetime is within its footprint. To ensure this area is available for on-site production, many states, counties, and cities have existing solar access ordinances, which declares that the right to use the natural resource of solar energy is a property right. For example, the city of Boulder, CO has a solar access ordinance, which guarantees access to sunlight for homeowners and renters in the city. This ordinance protects solar access of existing buildings by limiting the amount of shadow new development may cast on neighboring buildings, maintaining the potential for using renewable energy systems in buildings (City of Boulder 2006). Using a neighboring

field to generate electricity is not as favorable as a roof-mounted PV system; the area outside the building's footprint cannot be guaranteed to provide long-term generation because of the possibility of future development.

Wind resources for ZEBs are limited because of structural, noise, and wind pattern considerations, and are not typically installed on buildings. Some parking lots or adjacent areas may be used to produce energy from wind, but this resource is site specific and not widely available. Similar to PV generation in an adjacent parking lot, the wind resource is not necessarily guaranteed because it could be superseded by future development.

Renewable sources imported to the site, such as wood pellets, ethanol, or biodiesel can be valuable, but do not count as on-site renewable sources. Biofuels such as waste vegetable oil from waste streams and methane from human and animal wastes can also be valuable energy sources, but these materials are typically imported for the on-site processes.

The final option for supply-side renewable energy sources includes purchasing “green credits” or renewable sources such as wind power or utility PV systems that are available to the electrical grid. These central resources require infrastructure to move the energy to the building and are not always available. Buildings employing resources 3 and 4 in Table A-1 to achieve zero energy are considered off-site ZEBs. For example, a building can achieve an off-site ZEB for all of these definitions by purchasing wind energy. Although becoming an off-site ZEB can have little to do with design and a lot to do with the different sources of purchased off-site renewable energy, an off-site ZEB is still in line with the general concept of a ZEB.

A.2 Definitions

A zero energy building can be defined in several ways, depending on the boundary and the metric. Different definitions may be appropriate depending on the project goals and the values of the design team and building owner. For example, building owners typically care about energy costs. Organizations, such as DOE, are concerned with national energy numbers, and are typically interested in primary or source energy. A building designer may be interested in site energy use for energy code requirements. Finally, those who are concerned about pollution from power plants and the burning of fossil fuels may be interested in reducing emissions. Four commonly used definitions are: net zero site energy, net zero source energy, net zero energy costs, and net zero energy emissions.

- **Net Zero Site Energy:** A site ZEB produces at least as much energy as it uses in a year, when accounted for at the site.
- **Net Zero Source Energy:** A source ZEB produces at least as much energy as it uses in a year, when accounted for at the source. Source energy refers to the primary energy used to generate and deliver the energy to the site. To calculate a building's total source energy, imported and exported energy is multiplied by the appropriate site-to-source conversion multipliers.
- **Net Zero Energy Costs:** In a cost ZEB, the amount of money the utility pays the building owner for the energy the building exports to the grid is at least equal to the amount the owner pays the utility for the energy services and energy used over the year.
- **Net Zero Energy Emissions:** A net-zero emissions building produces at least as much emissions-free renewable energy as it uses from emissions-producing energy sources.

Each definition uses the grid for net use accounting and has different applicable renewable energy sources. Note that the definitions do apply for grid independent structures. For all definitions, supply-side option 2 can be used if this resource will be available for the life of the building. Off-site ZEBs can be achieved by purchasing renewable energy from off-site sources, or in the case of an off-site zero emissions building, purchasing emissions credits. In support of DOE's ZEB research needs, the following definition discussion refer to ZEBs that use supply side options available on site. For ZEBs

that have a portion of the renewable generation supplied by off-site sources, these buildings are referred to as “off-site ZEBs.”

A.3 Low- and Zero-Energy Buildings: Examples

To study the impacts of these ZEB definitions, we examined the six low-energy commercial buildings with respect to these definitions. These buildings were further investigated to determine additional PV system requirements to meet the ZEB goals. PV system array area and system capacity requirements for meeting site and source ZEB goals were determined in each case (see Table A-2). Annual electricity and natural gas site-to-source conversion multipliers (3.2 for electricity and 1.07 for natural gas) were applied to each building to determine source energy use (EIA 2005). For the all-electric buildings (Oberlin, Zion, and Cambria), the site ZEB and source ZEB are the same. CBF used a minimal amount of propane, and the TTF and BigHorn used natural gas for heating and water heating. Zion, TTF, and BigHorn are single-story buildings; Oberlin, Cambria, and CBF are two stories. We used the PV system simulation tool PVSyst v3.3 (Mermoud 1996) to calculate the expected annual performance of the PV system. Single-crystalline PV modules were modeled with 0.0° tilt, as we assumed the PV system would be mounted on a flat roof of each building. These modules provide the best available output per unit area of commercially available PV modules.

Table A-2 ZEB Example Summary

Building and PV System (DC Rating Size)	Site Energy Use (w/o PV) (MWh/yr)	Source Energy Use (w/o PV) (MWh/yr)	Actual Roof Area (footprint) (ft²) (m²)	Flat Roof Area (ft²) (m²) Needed for Source ZEB and Site ZEB with PV	PV System DC Size Needed for Source ZEB and Site ZEB
Oberlin-60 kW	118.8	380.2	8,500 (790)	10,800 (1,003)	120 kW
Zion-7.2 kW	91.6	293.1	11,726 (1,089)	6,100 (567)	73 kW
Cambria-17.2 kW	372.1	1,190.7	17,250 (1,603)	37,210 (3,457)	415 kW
CBF-4.2 kW	365.2	1,142.0	15,500 (1,440)	25,316 (2,352) Source ZEB 25,640 (2,382) Site ZEB	282 kW Source ZEB 286 kW Site ZEB
TTF-No PV	83.5	192.5	10,000 (929)	4,010 (373) Source ZEB 5,550 (516) Site ZEB	45 kW Source ZEB 62 kW Site ZEB
BigHorn-8.9 kW	490.4	901.0	38,923 (3,616)	18,449 (1,714) Source ZEB 31,742 (2,949) Site ZEB	206 kW Source ZEB 354 kW Site ZEB

A.4 How Definition Determines Design

Depending on the ZEB definition, the results can vary substantially. Each definition has advantages and disadvantages, which are discussed below.

A.4.1 Net zero site energy building

A site ZEB produces as much energy as it uses, when accounted for at the site. Generation examples include roof-mounted PV or solar hot water collectors (Table A-1, Option 1). Other site-specific on-site generation options such as small-scale wind power, parking lot-mounted PV systems, and low-impact

hydro (Table A-1, Option 2), may be available. As discussed earlier, it is preferable to have the on-site generation be within the building footprint.

A limitation of a site ZEB definition is that the values of various fuels at the source are not considered. For example, one energy unit of electricity used at the site is equivalent to one energy unit of natural gas at the site, but electricity is more than 3 times as valuable at the source. For all-electric buildings, a site ZEB is equivalent to a source ZEB. For buildings with significant gas use, a site ZEB will need to generate much more on-site electricity than a source ZEB. As an example, the TTF would require a 62-kWDC PV system to be a site ZEB, but only a 45-kWDC PV system for a source ZEB (Table A-2); this is because gas heating is a major end use. The net site definition encourages aggressive energy efficiency designs because on-site generated electricity has to offset gas use on a 1 to 1 basis.

A site ZEB can be easily verified through on-site measurements, whereas source energy or emissions ZEBs cannot be measured directly because site-to-source factors need to be determined. An easily measurable definition is important to accurately determine the progress toward meeting a ZEB goal.

A site ZEB has the fewest external fluctuations that influence the ZEB goal, and therefore provides the most repeatable and consistent definition. This is not the case for the cost ZEB definition because fluctuations in energy costs and rate structures over the life of a building affect the success in reaching net zero energy costs. For example, at BigHorn, natural gas prices varied 40% during the three-year monitoring period and electricity prices varied widely, mainly because of a partial shift from coal to natural gas for utility electricity production. Similarly, source energy conversion rates may change over the life of a building, depending on the type of power plant or power source mix the utility uses to provide electricity. However, for all the ZEB definitions, the impact of energy performance can affect the success in meeting a ZEB goal.

A building could be a site ZEB but not realize comparable energy cost savings. If peak demands and utility bills are not managed, the energy costs may or may not be similarly reduced. This was the case at Oberlin, which realized a 79% energy saving, but did not reduce peak demand charges. Uncontrolled demand charges resulted in a disproportionate energy cost saving of only 35%.

An additional design implication of a site ZEB is that this definition favors electric equipment that is more efficient at the site than its gas counterpart. For example, in a net site ZEB, electric heat pumps would be favored over natural gas furnaces for heating because they have a coefficient of performance from 2 to 4, while natural gas furnaces are about 90% efficient. This was the case at Oberlin, which had a net site ZEB goal that influenced the design decision for an all-electric ground source heat pump system.

A.4.2 Net zero source energy building

A source ZEB produces as much energy as it uses as measured at the source. To calculate a building's total source energy, both imported and exported energy are multiplied by the appropriate site-to-source energy factors. To make this calculation, power generation and transmission factors are needed. *Source Energy and Emission Factors for Energy Use in Buildings* (Deru and Torcellini 2006) used a life cycle assessment approach and determined national electricity and natural gas site-to-source energy factors of 3.37 and 1.12. Site gas energy use will have to be offset with on-site electricity generation on a 3.37 to 1 ratio (one unit of exported electricity for 3.37 units of site gas use) for a source ZEB. This definition could encourage the use of gas in as many end uses as possible (boilers, domestic hot water, dryers, desiccant dehumidifiers) to take advantage of this fuel switching and source accounting to reach this ZEB goal. For example, the higher the percent of total energy used at a site that is gas, the smaller the PV system required to be a source ZEB. At BigHorn, for a source ZEB, 18,500 ft² of PV are required; however, 31,750 ft² of PV are required for a site ZEB (Table A-2). In this case, almost twice the amount of PV is needed for a source ZEB over a site ZEB.

This definition also depends on the method used to calculate site-to-source electricity energy factors. National averages do not account for regional electricity generation differences. For example, in the

Northwest, where hydropower is used to generate significant electricity, the site-to-source multiplier is lower than the national number. In addition, national site-to-source energy factors do not account for hourly variations in the heat rate of power plants or how utilities dispatch generation facilities for peak loading. Electricity use at night could have fewer source impacts than electricity used during the peak utility time of day. Further work is needed to determine how utilities dispatch various forms of generation and the corresponding daily variations of heat rates and source rates. Regional time-dependent valuations (TDVs) for determining time-of-use source energy is one method used to account for variations in how and when energy is used. TDVs have been developed by the California Energy Commission to determine the hourly value of delivered energy for 16 zones in California (CEC 2005). Similar national TDVs would be valuable to accurately calculate source energy use to determine a building's success in reaching a source ZEB goal. A first step in understanding regional site-to-source multiplier differences is available (Deru and Torcellini 2006), with multipliers provided for the three primary grid interconnects and for each state.

There may be issues with the source ZEB definition when electricity is generated on site with gas from fossil fuels. The ZEB definitions state that the building must use renewable energy sources to achieve the ZEB goal; therefore, electricity generated on site from fossil fuels cannot be exported and count toward a ZEB goal. However, this is unlikely, because buildings are unlikely to need more heat than electricity and the inefficiencies of on-site electricity generation and exportation make this economically very unattractive. The best cost or energy pathways will determine the optimal combination of energy efficiency, on-site cogeneration, and on-site renewable energy generation.

The issue of unmanaged energy costs in a site ZEB is similar for a source ZEB. A building could be a source ZEB and not realize comparable energy cost savings. If peak demands and utility bills are not managed, the energy costs may or may not be similarly reduced.

A.4.3 Net zero energy cost building

A cost ZEB receives as much financial credit for exported energy as it is charged on the utility bills. The credit received for exported electricity (often referred to net energy generation) will have to offset energy, distribution, peak demand, taxes, and metering charges for electricity and gas use. A cost ZEB provides a relatively even comparison of fuel types used at the site as well as a surrogate for infrastructure. Therefore, the energy availability specific to the site and the competing fuel costs would determine the optimal solutions. However, as utility rates can vary widely, a building with consistent energy performance could meet the cost ZEB goal one year and not the next.

In wide-scale implementation scenarios, this definition may be ineffective because utility rates will change dramatically. As energy-efficient building technologies and renewable energy installations increase, the effects of large numbers of energy-efficient buildings must be considered in a given utility's service area. In addition to purchasing fuel to generate electricity, electric utilities must provide dependable service, maintain capacity to meet potential loads, meet obligations for maintaining and expanding infrastructure, and provide profitability for shareholders. The fixed costs associated with these activities result in rate structures that provide only limited incentive for consumers to create cost ZEBs. Trends in other utility sectors, such as water districts, indicate that as buildings become more efficient, and consequently have lower consumptive charges, the costs associated with infrastructure are increased. If significant numbers of buildings achieved a zero energy cost, then financial resources would not be available to maintain the infrastructure, and the utility companies would have to raise the fixed and demand charges.

For commercial buildings, a cost ZEB is typically the hardest to reach, and is very dependent on how a utility credits net electricity generation and the utility rate structure the building uses. One way to reach this goal in a small commercial building might be to use a utility rate that minimizes demand charges. For example, at Zion, for a site and source ZEB at current performance levels (about 65% energy savings without PV), a 73-kW PV system is needed. To be a cost ZEB, with the utility providing credit for net

electricity generation at avoided generation costs, a 100-kW PV system would be needed. A cost ZEB may be technically possible in this case, but the following characteristics would all be required to achieve this ZEB definition:

- High energy savings (Zion’s measured energy savings approach 65%).
- Aggressive demand management to allow PV to help offset demand. Without demand-responsive controls, PV systems cannot be relied upon to reduce peak demand charges. Additionally, the low peak demands enable the building to qualify for the small commercial rate structure.
- A favorable utility rate structure weighted toward energy use, not peak demand charges. Standard commercial rate structures often result in electricity charges that are typically split between peak demand and energy charges. The small building commercial rate structure for Zion, which has comparatively low peak demand rates and higher consumption rates, would not apply if the building used more than 35 kW for any 15-minute period over any time of the year. This small commercial rate includes a low demand charge of \$6.30/kW for all usage that exceeds 15 kW, and an energy charge of \$0.08/kWh for the first 1500 kWh and \$0.045/kWh for all additional kilowatt-hours. A time-of-use rate would also be advantageous for a cost ZEB.
- A net-metering agreement that credits excess electricity generation at avoided generation costs (\$0.027/kWh in this case), without capacity eligibility limits to PV system sizes. Avoided generation costs refer to how the utility credits the customer for net generation and is based on the costs associated with the utility not having to generate this energy. A far more favorable net-metering agreement would credit the net generation at the full retail rate. This is considered “true” net metering, and would be the favored net metering arrangement in a cost ZEB. The net-metering agreement also must allow the excess generation credit to be used for offsetting energy-related and nonenergy charges, such as monthly meter charges, demand charges, and taxes.

In the Zion net cost ZEB example, a PV system 30% larger than a site or source ZEB PV system would be required to reach the net cost ZEB goal. For utility rates that do not allow the net generation credit to be applied to nonenergy charges, a net cost ZEB would not be possible, irrespective of the size of the PV system, the energy or demand savings, or how the rates weight energy and nonenergy charges.

If demand charges account for a significant portion of the utility bills, a net cost ZEB becomes difficult. For example, Oberlin’s rate structure is not weighted toward energy rates combined with minimal demand savings. A 430-kW PV system would be required for a cost ZEB at Oberlin at current levels of performance. This is 3.6 times the size of the PV system Oberlin would need to be a site or source ZEB. For this 13,600 ft² building to be a net cost ZEB, a PV system approaching 40,000 ft² would be required—much larger than the building footprint.

If two-way or net metering is not available, on-site energy storage and advanced demand-responsive controls to manage peak demand charges should be included in the design and operation of cost ZEBs. It may be more effective to store excess PV energy and use it at a later time to reduce demand charges rather than export the energy to the grid.

A.4.4 Net zero energy emissions building

An emissions-based ZEB produces at least as much emissions-free renewable energy as it uses from emissions-producing energy sources. An on-site emission ZEB offsets its emissions using supply-side options 1 and 2 in Table A-1. If an all electric building gets all of its electricity from an off-site zero emissions source (such as hydro, nuclear, or large scale wind farms), then it is already zero emissions and does not have to generate any on-site renewable energy to offset emissions. However, if the same building uses natural gas for heating, then it will need to generate and export enough emissions-free

renewable energy to offset the emissions from the natural gas use. Purchasing emissions offsets from other sources would be considered an off-site zero emissions building.

Success achieving an emissions ZEB depends on the generation source of the electricity used. Emissions are highly variable depending on the source of electricity, ranging from nuclear, coal, hydro, and other utility generation sources. One could argue that any building built in an area that has a large hydro or nuclear contribution to the regional electricity generation mix would have fewer emissions than a similar building in a region with a predominantly coal-fired generation mix. Therefore, an emissions ZEB would need a smaller PV system in areas with a large hydro or nuclear contribution as compared to a similar building supplied by a utility with a large coal-fired generation contribution.

The net zero emissions ZEB definition has similar calculation difficulties previously discussed with the source ZEB definition. Many of these difficulties are related to the uncertainty in determining the generation source of electricity. Like the source definition, one would need to understand the utility dispatch strategy and generation source ratio to determine emissions from each of these sources.

A.4.5 ZEB definitions applied to a sample of current generation low-energy buildings

Each of these leading-edge case study buildings demonstrates the progress toward achieving ZEB goals in real-world examples. The one-story buildings—Zion, BigHorn, and TTF—could achieve ZEB within their roof areas for all the definitions except cost ZEB. ZEB is not feasible for the two-story buildings unless their loads are further reduced. For Oberlin (the building currently closest to meeting a ZEB goal), the annual PV production is still less than the best-case energy consumption scenario. Oberlin is currently installing another 100-kW PV system in the parking lot (total installed DC capacity will be 160 kW), which will be tied into the building's electrical system. We expect that the building will achieve a site, source, and emissions ZEB, but that a cost ZEB will be difficult to reach without further demand management controls. To accomplish a ZEB, the PV system has been extended past the building footprint.

None of the buildings could clearly be cost ZEBs with the current rate structures. Zion could be the closest because of its aggressive demand management, favorable utility rate structure, and efficient use of energy. A cost ZEB is the most difficult ZEB goal to reach because typical commercial rate structures do not allow for net metering such that exported electricity can offset all other utility charges. To reach a cost ZEB goal, the credit received for exported electricity would have to offset energy, distribution, peak demand, taxes, and metering charges for both electricity and gas use.

A.4.6 The ZEB definition selected can have an impact on future ZEB designs

The zero energy definition affects how buildings are designed to achieve the goal. It can emphasize energy efficiency, supply-side strategies, purchased energy sources, utility rate structures, or whether fuel-switching and conversion accounting can help meet the goal. Table A-3 highlights key characteristics of each definition.

A source ZEB definition can emphasize gas end uses over the electric counterparts to take advantage of fuel switching and source accounting to reach a source ZEB goal. Conversely, a site ZEB can emphasize electric heat pumps for heating end uses over the gas counterpart. For a cost ZEB, demand management and on-site energy storage are important design considerations, combined with selecting a favorable utility rate structure with net metering. An emissions ZEB is highly dependent on the utility electric generation source. Off-site ZEBs can be reached just by purchasing off-site renewable energy, no demand or energy savings needed. Consistent ZEB definitions are needed for those who research, fund, design, and evaluate ZEBs.

Table A-3 ZEB Definitions Summary

Definition	Pluses	Minuses	Other Issues
Site ZEB	<ul style="list-style-type: none"> • Easy to implement. • Verifiable through on-site measurement. • Conservative approach to achieving ZEB. • No externalities affect performance, can track success over time. • Easy for the building community to understand and communicate. • Encourages energy-efficient building designs. 	<ul style="list-style-type: none"> • Requires more PV export to offset natural gas. • Does not consider all utility costs (can have a low load factor). • Not able to equate fuel types. • Does not account for nonenergy differences between fuel types (supply availability, pollution). 	
Source ZEB	<ul style="list-style-type: none"> • Able to equate actual value of fuel types used at the site. • Better model for impact on national energy system. • Easier ZEB to reach. 	<ul style="list-style-type: none"> • Does not account for nonenergy differences between fuel types (supply availability, pollution). • Source calculations too broad (do not account for regional or daily variations in electricity generation heat rates). • Source energy use accounting “gaming” can have a larger impact than efficiency technologies. • Does not consider all energy costs (can have a low load factor). 	<ul style="list-style-type: none"> • Need to develop site-to-source conversion factors that require significant amounts of information to define.
Cost ZEB	<ul style="list-style-type: none"> • Easy to implement and measure. • Market forces result in a good balance between fuel types. • Encourages demand-responsive control. • Verifiable from utility bills. 	<ul style="list-style-type: none"> • May not reflect impact to national grid for demand, as extra PV generation can be more valuable for reducing demand with on-site storage than exporting to the grid. • Requires net-metering agreements such that exported electricity can offset energy and nonenergy charges. • Highly volatile energy rates make for difficult tracking over time. 	<ul style="list-style-type: none"> • Offsetting monthly service and infrastructure charges require going beyond ZEB. • Net metering is not well established, often with capacity limits and at buyback rates lower than retail rates.
Emissions ZEB	<ul style="list-style-type: none"> • Better model for green power. • Accounts for nonenergy differences between fuel types (greenhouse gases, pollution). • Easier ZEB to reach. 		<ul style="list-style-type: none"> • Need appropriate fuel factors for emissions.

APPENDIX B: NATIONAL DAYLIGHTING POTENTIAL

We used currently available CBECS buildings and national weighting factors (EIA 2005a) to determine total square footage in all commercial buildings in the United States that have daylighting potential. Data used in CBECS include total floor area, number of floors, and the building-weighting factor. We used an internally developed CBECS analysis tool “NREL CBECS Data Analyzer, Version 1.0.0.12” with CBECS Public Use Data for 1999. The CBECS Data Analyzer program enabled us to extract and analyze data on 5,430 commercial buildings and apply results with weighting factors to the full commercial building sector.

The assumptions required to use the CBECS data set included:

- Aspect ratio of 1, 3, or a random aspect ratio of 1 to 3 applied to each of the CBECS buildings, evenly distributed (average of 2)
- Daylighting potential in all 15-ft (4.6-m) perimeter zones (shown in Figure B-1)
- 100% daylighting potential on top floor, through toplit and sidelit daylighting
- No daylighting potential in first- and second-floor core zones
- For CBECS buildings classified as 15–25 floors, random number of floors between 15 and 25
- For CBECS buildings with more than 25 floors, a 50-floor building is assumed
- Identical floor area for each floor
- 1999 CBECS square footage and number of floors data combined with weighting factors to determine national commercial building stock daylighting potential

From the CBECS dataset and associated weighting factors, the following daylighting potential results are provided:

- Seventy-seven to eighty-two percent of all square footage in the commercial building stock has the potential to be daylit through a combination of toplit and sidelit systems, in zones within 15 feet (4.6 m) of an exterior wall or the top floor with a roof.
- The range of potentially daylit square footage depends on assumed aspect ratio. If all buildings in CBECS were square (aspect ratio of 1), 77% of all square footage could be daylit. If all buildings had an aspect ratio of 3, the percentage increases to 82%. Using a random distribution of aspect ratio (with an average of 2), 80% of all square footage has daylighting potential.
- Sixty percent of all square footage in commercial buildings could be toplit through an exterior ceiling, as shown in Figure B-2.

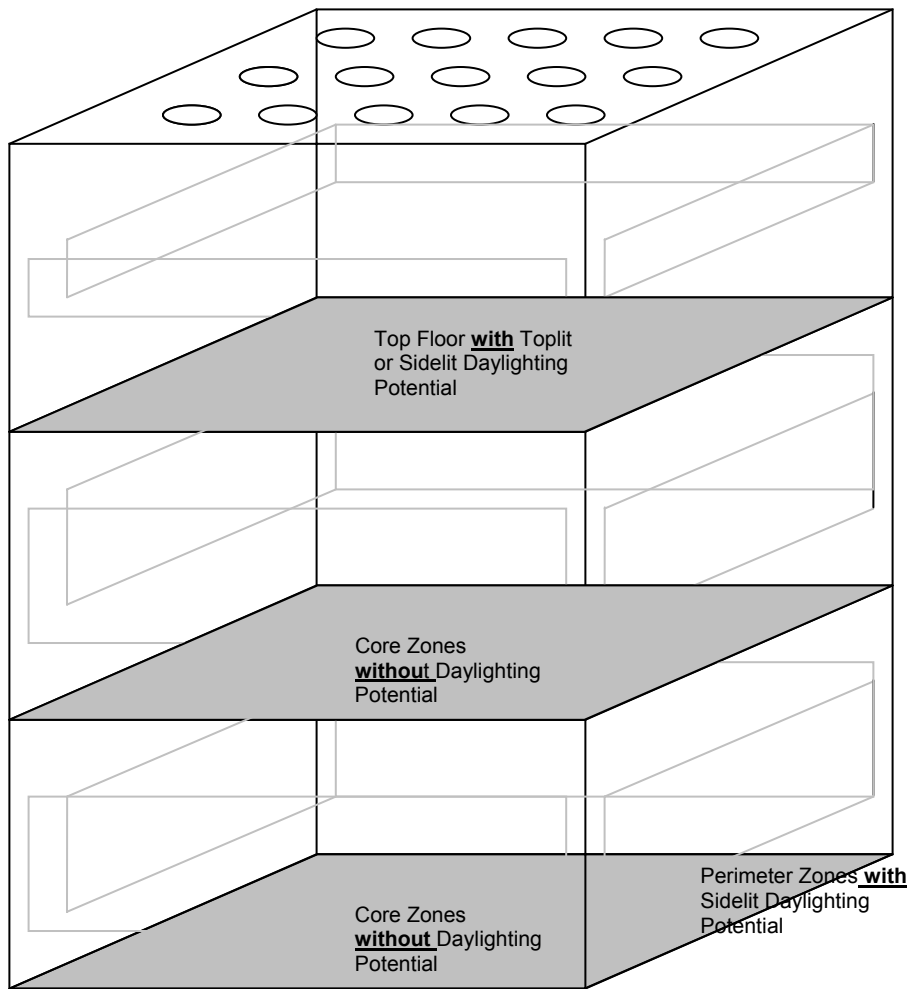

Figure B-1 Perimeter and core zones daylighting potential

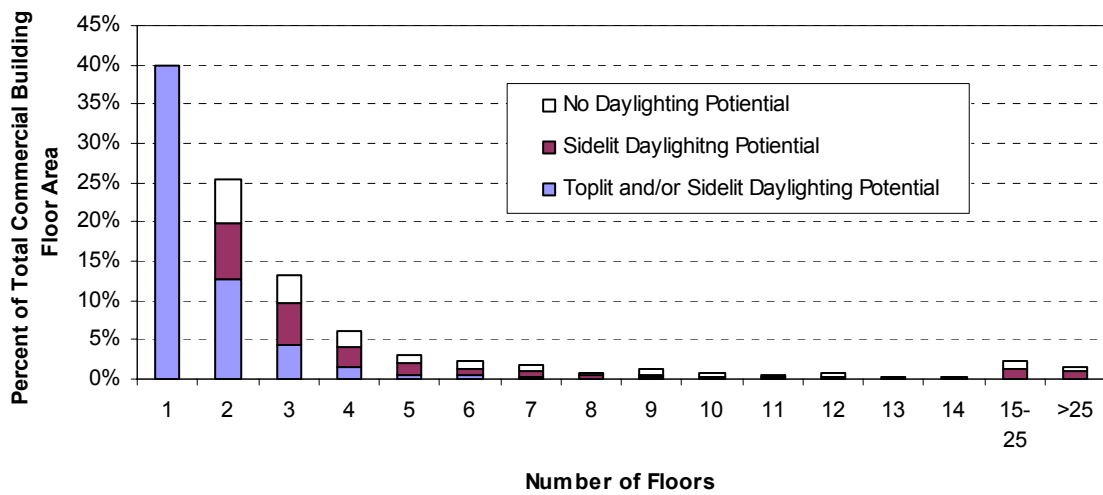

Figure B-2 Toplit and sidelit daylighting potential by number of floors

REPORT DOCUMENTATION PAGE

Form Approved
OMB No. 0704-0188

The public reporting burden for this collection of information is estimated to average 1 hour per response, including the time for reviewing instructions, searching existing data sources, gathering and maintaining the data needed, and completing and reviewing the collection of information. Send comments regarding this burden estimate or any other aspect of this collection of information, including suggestions for reducing the burden, to Department of Defense, Executive Services and Communications Directorate (0704-0188). Respondents should be aware that notwithstanding any other provision of law, no person shall be subject to any penalty for failing to comply with a collection of information if it does not display a currently valid OMB control number.

PLEASE DO NOT RETURN YOUR FORM TO THE ABOVE ORGANIZATION.

1. REPORT DATE (DD-MM-YYYY) June 2006			2. REPORT TYPE Technical Report		3. DATES COVERED (From - To)	
4. TITLE AND SUBTITLE Lessons Learned from Case Studies of Six High-Performance Buildings				5a. CONTRACT NUMBER DE-AC36-99-GO10337		
				5b. GRANT NUMBER		
				5c. PROGRAM ELEMENT NUMBER		
6. AUTHOR(S) P. Torcellini, S. Pless, M. Deru, B. Griffith, N. Long, and R. Judkoff				5d. PROJECT NUMBER NREL/TP-550-37542		
				5e. TASK NUMBER BEC61012		
				5f. WORK UNIT NUMBER		
7. PERFORMING ORGANIZATION NAME(S) AND ADDRESS(ES) National Renewable Energy Laboratory 1617 Cole Blvd. Golden, CO 80401-3393				8. PERFORMING ORGANIZATION REPORT NUMBER NREL/TP-550-37542		
9. SPONSORING/MONITORING AGENCY NAME(S) AND ADDRESS(ES)				10. SPONSOR/MONITOR'S ACRONYM(S) NREL		
				11. SPONSORING/MONITORING AGENCY REPORT NUMBER		
12. DISTRIBUTION AVAILABILITY STATEMENT National Technical Information Service U.S. Department of Commerce 5285 Port Royal Road Springfield, VA 22161						
13. SUPPLEMENTARY NOTES						
14. ABSTRACT (Maximum 200 Words) Commercial buildings have a significant impact on energy use and the environment. They account for approximately 18% (17.9 quads) of the total primary energy consumption in the United States (DOE 2005). The energy used by the building sector continues to increase, primarily because new buildings are added to the national building stock faster than old buildings are retired. Energy consumption by commercial buildings will continue to increase until buildings can be designed to produce more energy than they consume. As a result, the U.S. Department of Energy's (DOE) Building Technologies Program has established a goal to create the technology and knowledgebase for marketable zero-energy commercial buildings (ZEBs) by 2025.						
15. SUBJECT TERMS zero energy building; ZEB; energy consumption; commercial building; zion national park visitor center; oberlin; bighorn; thermal test facility; chesapeake bay foundation; pennsylvania department of environmental protection						
16. SECURITY CLASSIFICATION OF:			17. LIMITATION OF ABSTRACT UL	18. NUMBER OF PAGES	19a. NAME OF RESPONSIBLE PERSON	
a. REPORT Unclassified	b. ABSTRACT Unclassified	c. THIS PAGE Unclassified			19b. TELEPHONE NUMBER (Include area code)	

Standard Form 298 (Rev. 8/98)
Prescribed by ANSI Std. Z39.18