

Evaluation of a High-Performance Solar Home in Loveland, Colorado

Journal Article
NREL/JA-550-40374
August 2006

Preprint

R. Hendron and M. Eastment
National Renewable Energy Laboratory

E. Hancock and G. Barker
Mountain Energy Partnership

P. Reeves
Partnership for Resource Conservation

To be published in the Journal of Solar Energy Engineering
(Paper No. SOL-05-1063)

NREL is operated by Midwest Research Institute • Battelle Contract No. DE-AC36-99-GO10337



NOTICE

The submitted manuscript has been offered by an employee of the Midwest Research Institute (MRI), a contractor of the US Government under Contract No. DE-AC36-99GO10337. Accordingly, the US Government and MRI retain a nonexclusive royalty-free license to publish or reproduce the published form of this contribution, or allow others to do so, for US Government purposes.

This report was prepared as an account of work sponsored by an agency of the United States government. Neither the United States government nor any agency thereof, nor any of their employees, makes any warranty, express or implied, or assumes any legal liability or responsibility for the accuracy, completeness, or usefulness of any information, apparatus, product, or process disclosed, or represents that its use would not infringe privately owned rights. Reference herein to any specific commercial product, process, or service by trade name, trademark, manufacturer, or otherwise does not necessarily constitute or imply its endorsement, recommendation, or favoring by the United States government or any agency thereof. The views and opinions of authors expressed herein do not necessarily state or reflect those of the United States government or any agency thereof.

Available electronically at <http://www.osti.gov/bridge>

Available for a processing fee to U.S. Department of Energy and its contractors, in paper, from:

U.S. Department of Energy
Office of Scientific and Technical Information
P.O. Box 62
Oak Ridge, TN 37831-0062
phone: 865.576.8401
fax: 865.576.5728
email: <mailto:reports@adonis.osti.gov>

Available for sale to the public, in paper, from:

U.S. Department of Commerce
National Technical Information Service
5285 Port Royal Road
Springfield, VA 22161
phone: 800.553.6847
fax: 703.605.6900
email: orders@ntis.fedworld.gov
online ordering: <http://www.ntis.gov/ordering.htm>



**EVALUATION OF A HIGH-PERFORMANCE
SOLAR HOME IN LOVELAND, COLORADO**

Robert Hendron

National Renewable Energy Laboratory
Golden, CO

Mark Eastment

National Renewable Energy Laboratory
Golden, CO

Ed Hancock

Mountain Energy Partnership
Boulder, CO

Greg Barker

Mountain Energy Partnership
Boulder, CO

Paul Reeves

Partnership for Resource Conservation
Boulder, CO

Abstract

Building America (BA) partner McStain Neighborhoods built the Discovery House in Loveland, Colorado, with an extensive package of energy-efficient features, including a high-performance envelope, efficient mechanical systems, a solar water heater integrated with the space-heating system, a heat-recovery ventilator (HRV), and ENERGY STAR™ appliances.

The National Renewable Energy Laboratory (NREL) and Building Science Consortium (BSC) conducted short-term field-testing and building energy simulations to evaluate the performance of the house. These evaluations are utilized by BA to improve future prototype designs and to identify critical research needs.

The Discovery House building envelope and ducts were very tight under normal operating conditions. The HRV provided fresh air at a rate of about 35 l/s (75 cfm), consistent with the recommendations of ASHRAE Standard 62.2. The solar hot water system is expected to meet the bulk of the domestic hot water (DHW) load (>83%), but only about 12% of the space-heating load. DOE-2.2 simulations predict whole-house source energy savings of 54% compared to the BA Benchmark [1]. The largest contributors to energy savings beyond McStain's standard practice are the solar water heater, HRV, improved air distribution, high-efficiency boiler, and compact fluorescent lighting package.

Nomenclature

ACH	Air changes per hour
AFUE	Annual fuel utilization efficiency
AH	Air handler
BA	Building America
CAE	Combined annual efficiency
DHW	Domestic hot water
EF	Energy factor
EqLA	Equivalent leakage area
HRV	Heat recovery ventilator
kWh _t	Kilowatt-hours of thermal energy
RMC	Remaining moisture content
SEER	Seasonal energy efficiency ratio
SHGC	Solar heat gain coefficient
TRNSYS	TRaNsient SYstems Simulation

Introduction

Building America is a partnership between the U.S. Department of Energy (DOE) and the building industry to develop production-ready building systems that lead to whole-house energy savings of 50% by 2010 and 90% by 2020. McStain Neighborhoods is a partner to BSC, one of five Building America industry teams. Targeting 40-50% energy savings, McStain and BSC designed and built the Discovery House in Loveland, Colorado, with a large number of energy-efficiency measures. The Discovery House is a 233-m² (2512-ft²), two-story home with a 59-m² (636-ft²) conditioned basement (Figure 1). In addition to a high-performance envelope and efficient mechanical systems, this home utilizes a passive solar design, a solar hot water loop integrated with the space-heating system, an HRV, compact fluorescent lighting, and energy-efficient appliances. Other key design specifications are summarized in Table 1. Features that are not part of McStain's standard practice in the Denver metropolitan area are presented in italics. For this particular project, NREL began its participation after the design and construction had been completed. A more complete description of the Discovery House and the design philosophy behind it can be found in an article published by McStain Neighborhoods [2].



Figure 1. McStain Discovery House (view from south)

Table 1. McStain Discovery House Key Specifications

Ceiling	R-44+ dry-blown cellulose
Walls	2x6 61-cm (24-in) on-center (oc), R-3.3 m ² ·K/W (R-19 ft ² ·h·°F/Btu) damp-spray cellulose insulation and R-0.7 m ² ·K/W (R-4 ft ² ·h·°F/Btu) 1.9-cm (3/4-in) XPS, 1.1-cm (7/16-in) OSB exterior; R-3.3 m ² ·K/W (R-19 ft ² ·h·°F/Btu) cellulose 2x6 61-cm (24-in) oc to garage
Basement walls	R-1.9 m ² ·K/W (R-11 ft ² ·h·°F/Btu) fiberglass batts with vinyl facers draped on walls
Basement slab	2.5-cm (1-in) R-0.9 m ² ·K/W (R-5 ft ² ·h·°F/Btu) XPS and 15-cm (6-in) EPS void material, radiant slab heating
Windows	Vinyl frame, Low-E, spectrally selective double-glazing, U = 2.0 W/m ² ·K (0.35 Btu/h·ft ² ·°F), SHGC = 0.34, movable awnings, thermostatically-controlled motorized windows
Space heating	Gas boiler in basement, 29 kW (100 kBtu/hr), 0.90 CAE, solar assisted, radiant basement slab, heating coil in air handler
Space cooling	19.2 SEER split system, two 472 l/s (1000-cfm) whole-house fans, manual control
DHW	Gas boiler, 0.90 CAE, 29 kW (100 kBtu/hr), 129-liter (34-gal) tank, solar assisted, drainback system, three 1.2 m x 2.4 m (4 ft x 8 ft) collectors, 681-liter (180-gal) solar tank, recirculation loop on timer
Ducts	Uninsulated metal with mastic in basement, floor joist spaces, and interior walls; fully ducted returns (first and second floors)
Ventilation	Heat recovery ventilator, 58 l/s (123 CFM), 60-66% sensible effectiveness, fan-cycling control for intermittent mixing, temperature-controlled window operation
Other	90% compact fluorescent lighting (CFL) package and ENERGY STAR appliances (weight sensing horizontal axis clothes washer, soil sensing dishwasher, dryer with temperature and moisture feedback)

Both field testing and modeling are important components in the evaluation of any prototype house. Modeling provides the generalized energy calculations necessary to compare a prototype house to a standard point of reference, such as the BA Benchmark. Because weather, occupant behavior, and miscellaneous electric loads can dramatically affect actual energy use, it is essential that simulations be used to separate the objective performance of a prototype house from the effects of these uncontrolled variables. Modeling also allows the evaluation of “what-if” scenarios, where alternative design features are compared to those of the as-built prototype house. However, short-term field evaluations of actual prototype building systems provide information that modeling alone cannot. Field testing increases confidence in building models by improving accuracy in areas that are difficult to know without direct measurements, such as duct and envelope air leakage, solar collector efficiency, and even the whole-building heat loss coefficient (UA) [3, 4]. Longer-term monitoring of occupied houses can also be used to examine

the interactions between building systems, people, and weather, and to help calibrate the model if desired [5]. NREL formulates detailed test and simulation plans based on the specific research questions being addressed for each project [6].

For the Discovery House, NREL conducted energy simulations that were informed by a series of short-term tests conducted in June 2004. These tests focused on characterizing the air infiltration, duct leakage, ventilation system, solar combo system, and appliances. Once the house became occupied in March 2005, NREL initiated long-term monitoring to provide insights and interpretations that would not be available through short-term testing or simulation. The results of this long-term monitoring program (including direct measurements, utility bills, and homeowner interviews) will be documented in a follow-up publication.

Short-Term Field Test Results

Air Infiltration and ventilation

Building envelope and duct leakage tests were conducted by BSC personnel using a blower door and duct blaster. A summary of the measurements, adjusted for altitude and temperature, is shown in Table 2.

Table 2. Air Leakage Characteristics Measured by BSC

Test	Description	Value
Blower Door	l/s @ 50 Pa (CFM50)	549 (1162)
	Estimated ACH _{nat}	0.180
Duct Blaster	l/s leakage @ 25 Pa (CFM25 _{total})	190 (403)
	l/s leakage to outside @ 25 Pa (CFM25 _{outside})	11 (23)
	l/s supply leakage @ 25 Pa (CFM25 _{total, supply})	151 (319)
	l/s supply lkg to outside @ 25 Pa (CFM25 _{outside, supply} (l/s))	10 (22)

These measurements verified compliance with the BSC air-leakage specifications of less than 1057 l/s @ 50 Pa (2239 CFM50), or 16 cm² (2.5 in²) EqLA per 9.3 m² (100 ft²) of surface area, and less than 5% duct leakage to the outside, corresponding to 28 l/s (60 cfm) based on 566 l/s (1200 cfm) total airflow. The design target of 10% total duct leakage, or 57 l/s (120 cfm), was not met during initial testing, but additional air-sealing steps taken by the builder reduced duct leakage from 136 l/s (289 cfm) to about 64 l/s (135 cfm) on the supply side. Total duct leakage was not measured after these improvements were made, but it is safe to say that the target level of 57 l/s (120 cfm) was not quite met.

The NREL multi-zone tracer-gas monitoring system was installed in the Discovery House from June 13 to 17, with sample points on each floor, including the basement. Air exchange rates were measured for several different operating conditions, with and without the air-handler fan and HRV operating. The measured hourly average air exchange rates are displayed in Figure 2. The outside temperature during the test period was fairly mild and peaked as high as 35°C (95°F) on some days while remaining below 16°C (60°F) on other days (usually when overcast). Active space conditioning was unnecessary and was not employed during the test period.

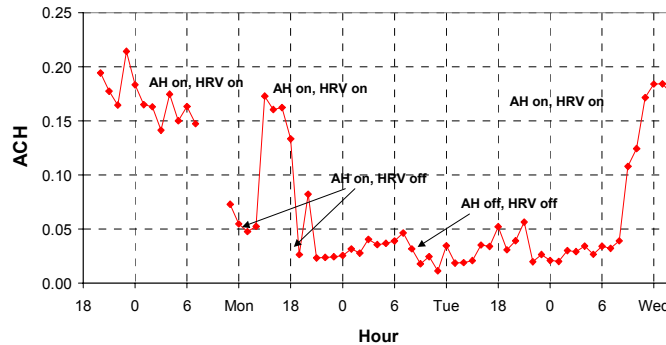

Figure 2. Tracer gas measurements at the Discovery House

From 1800 h Sunday, June 13, through 0700 h Monday, June 14, the house was in normal operating mode with the HRV on at low speed and the air-handler operating continuously. The measured air exchange rate during this period was between 0.15 and 0.20 air changes per hour (ACH), depending on wind speed and temperature difference. The HRV was turned off at 0800 h on Monday, turned on again at 1400 h and off again at 1800 h. This is commonly referred to as a "bump" test. The difference between the on and off periods was about 0.12-0.13 ACH (33-35 l/s, or 69-75 cfm) and represents the net air exchange attributable to operation of the HRV. Another bump test was performed on Wednesday with similar results. From 1800 h Monday until 0800 h Wednesday, the house operated without ventilation. The measured air-exchange rate without ventilation was between 0.02 and 0.05 ACH. Additional ventilation was clearly an important and necessary feature of this house. The design ventilation rate for the HRV was 35 l/s (75 cfm) at low speed and 83 l/s (175 cfm) at high speed. Based on a conditioned floor area of 292 m² (3148 ft²), including a basement and three bedrooms, the ventilation rate recommended by ASHRAE Standard 62.2 is 35 l/s (75 cfm). The design target appears to have been met within the accuracy of the tracer gas measurements.

The air handler (AH) was turned off from 0800 h on Tuesday, June 15, until 0800 h on Wednesday, June 16. The effect on ACH was negligible, perhaps 0.01-0.02 ACH (3-6 l/s, or 6-12 cfm). This is consistent with our expectations for ducts located in conditioned space and is also consistent with the duct blaster results measured by BSC (11 l/s, or 23 cfm @ 25 Pa).

The interior temperatures of the house during the test period are shown in Figure 3. Because the heating and cooling functions were not active during the test period, these profiles suggest that the air was well mixed during the tracer gas test. In addition, the energy efficiency

measures appeared to be effective in keeping the interior temperature stable during mild weather conditions without the need for space conditioning.

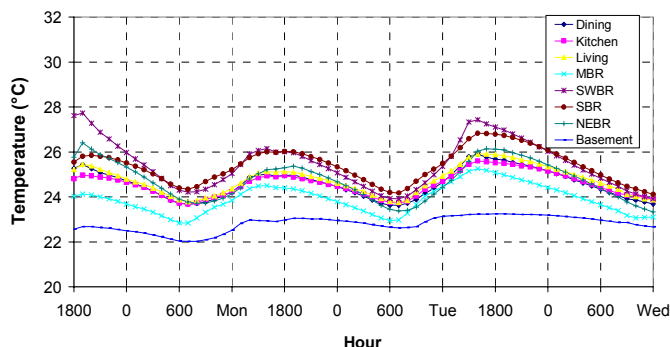

Figure 3. Interior temperatures during the first week of short-term testing

Appliances

Three of the energy-efficient appliances (dishwasher, clothes washer, clothes dryer) used in the Discovery House were evaluated as part of this test. Because occupant behavior can have such a large effect on energy and hot water use for these appliances, NREL was interested in characterizing their performance beyond the basic information provided on the EnergyGuide labels.

The clothes washer in the Discovery House was an ENERGY STAR-rated, 0.09-m³ (3.18-ft³) horizontal-axis machine with a thermostatic control valve to adjust the ratio of hot and cold water entering the tub, an internal heater to boost the hot-water temperature for the “sanitary” cycle, and a weight sensor to adjust water level based on the size of the load. The washer was run with 1.4 kg (3 lb) and 3.2 kg (7 lb) test loads using each of the five available wash/rinse cycles (cold/cold, warm/cold, warm/warm, hot/cold, extra hot/cold). This series of tests was intended to duplicate as nearly as possible the DOE standard appliance test procedures, used as the basis for calculating the information published on the EnergyGuide label. The test loads consisted of clean white 100% cotton t-shirts; laundry detergent was not used.

The measured hot water and machine energy use during the tests are shown in Figures 4 and 5. All test cycles consumed significantly less hot water than the BA Benchmark, and all of the cycles except the sanitary wash cycle (extra hot/cold) used less machine energy. (In fact, the sanitary cycle not only used a large amount of energy to heat the water to about 66°C (150°F), but the cycle duration exceeded 2 hours.) As expected, the automatic water-level control feature significantly reduced the amount of hot water consumption when the smaller 1.4 kg (3 lb) test load was used. The effects of wash and rinse temperatures on hot water use can also be seen in Figure 4. It is noteworthy that this machine used a small amount of hot water during the cold wash cycle to maintain a temperature of about 21°C (70°F) for the purpose of detergent activation.

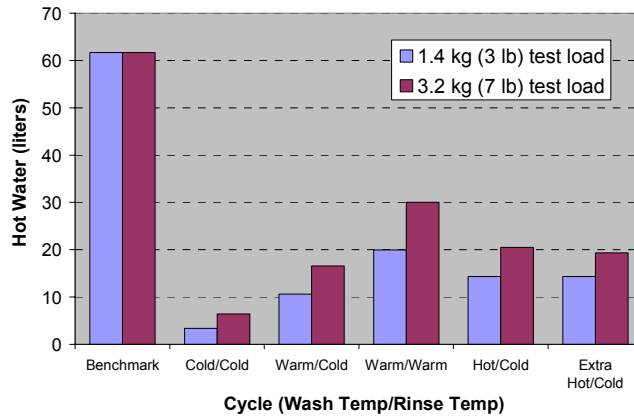

Figure 4. Clothes washer hot water use under various operating conditions; extra rinse used for Warm/Cold and 1.4 kg (3 lb) Warm/Warm cycles

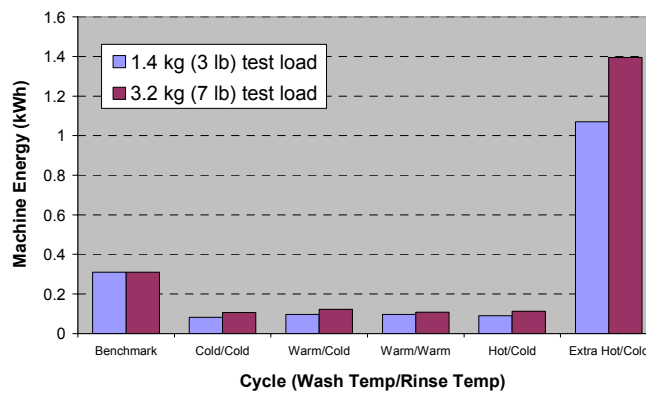

Figure 5. Clothes washer machine energy use under various operating conditions; extra rinse used for Warm/Cold and 1.4 kg (3 lb) Warm/Warm cycles

Clothes dryers do not have EnergyGuide labels and cannot qualify for ENERGY STAR. However, the dryer in the Discovery House had moisture and temperature sensors designed to reduce drying time and save energy by optimizing the amount of heat added and by automatically turning off the dryer when the clothes are dry. In addition, the ENERGY STAR clothes washer was expected to yield indirect energy savings for the dryer by reducing the remaining moisture content (RMC) in the clothes at the end of the spin cycle. RMC is defined as the weight of the water remaining in the damp clothes after the wash cycle divided by the dry weight.

Figures 6 and 7 present dryer electricity and natural gas use corresponding to the five clothes washer test cycles discussed above. The three cases identified as “Cold/High/High” were identical except for the wash temperature, which should not affect dryer energy use. Unfortunately, electricity data for one of the 1.4 kg (3 lb) cycles were accidentally overwritten following the test, and could not be reported. Energy use was substantially less than the Benchmark value for nearly all of the test cycles. However, the drying times did not seem to be faster than usual, averaging 30 minutes for the 1.4 kg (3 lb) loads and 40 minutes for the 3.2 kg

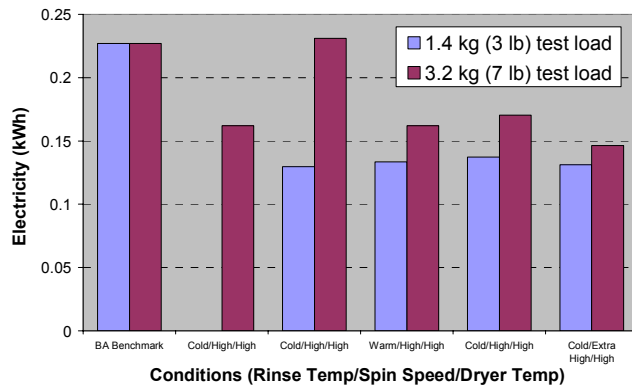

Figure 6. Clothes-dryer electricity use under various operating conditions

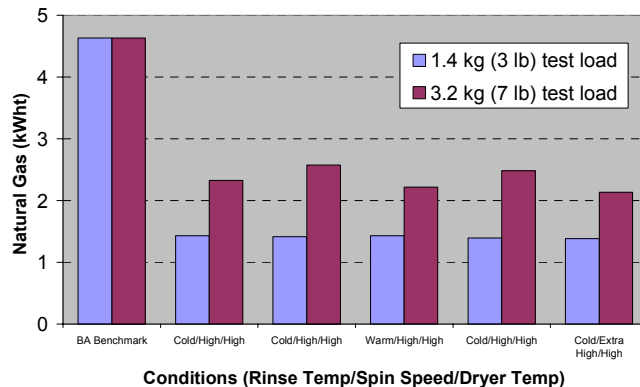

Figure 7. Clothes-dryer natural gas use under various operating conditions

(7 lb) loads. In fact, several 5.9 kg (12.9 lb) loads (full loads according to the DOE test procedures) were run, and the drying times averaged about 90-120 minutes. One of the 1.4 kg (7 lb) loads used much more machine energy than the others and tended to cycle on and off much more frequently. There was no clear explanation suggested by the data, so the unusually high dryer energy was likely caused by an anomaly in the dryer load, such as bunching or some other random effect.

The dishwasher installed in the Discovery House included five different wash levels, a soil sensor that adjusts wash time based on the dirtiness of the dishes, and a heated drying option. The dishwasher was operated using a test load consisting of eight place settings of typical ceramic dishes and stainless steel silverware. Most cycles were run with clean dishes. For cycles with dirty dishes, a controlled amount of spaghetti sauce was brushed on the dishes, which were then cooked in the microwave for about 20 seconds to simulate the effects of a typical meal.

The electricity and hot water use of the dishwasher under a variety of operating conditions are summarized in Figure 8. The dishwasher used less energy than the BA Benchmark for both the machine and hot water under each of the conditions tested. However, the results indicate that the electric heaters used in the power dry option nearly double the amount of

machine electrical energy compared to the air-dry option. The data also suggest that the soil sensor has a very large effect on both the hot water use and the machine energy. Ultimately, user-controlled operating choices will determine whether this ENERGY STAR dishwasher saves energy compared to a typical dishwasher.

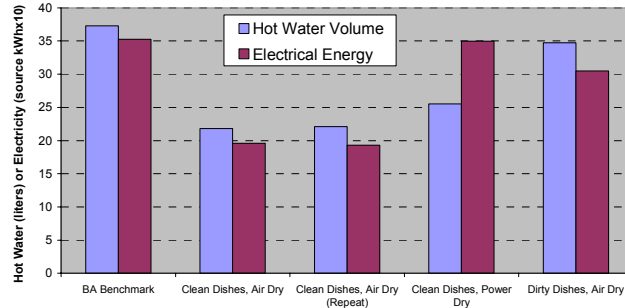

Figure 8. Dishwasher electricity and hot water consumption under various test conditions

Solar Hot Water and Space Heating

A schematic of the combined solar hot water and space heating system in the Discovery House is shown in Figure 9. The thermostat on the solar storage tank controls two solenoid valves wired in parallel, one normally open and one normally closed. When the storage tank temperature is above the thermostat setting (currently 43°C, or 110°F) and if either space heat through the air handler heating coil or space heat through the hydronic floor in the basement is called for, the respective circulation loop will be directed through the solar storage tank to collect heat. If the storage tank is not hot enough then the loop will be directed through the boiler to collect heat.

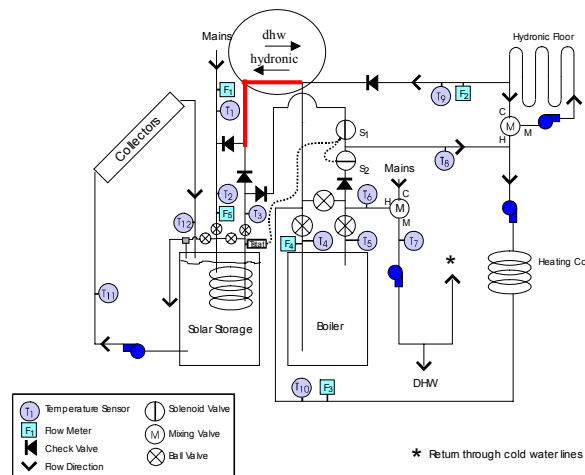

Figure 9. Schematic design of domestic hot water and space-heating system

During short-term testing of the solar hot water system, two performance issues became apparent. The system did not always begin circulating water to the collector when weather conditions indicated it should, and the system was short cycling once it got started. The short cycling problem was traced to an oversized pump, which was circulating too much flow (about 0.38 l/s, or 6 gpm) to the collector, resulting in a temperature rise that was too small. This issue was partly corrected by adjusting a valve to increase the pressure head, thereby reducing the flow rate to a more reasonable level (about 0.13 l/s, or 2 gpm). As a longer-term solution, NREL has recommended that two smaller pumps be used in place of the current pump. These pumps should be installed in series to provide sufficient pressure head during start-up, after which time one pump could be turned off to reduce the flow.

The system start-up issue appeared to be a result of temperature readings that were not representative of the actual supply and return temperatures to the solar collector. The return temperature sensor on the collector was originally located outside of the collector on the return pipe. This sensor was moved to the back of the absorber plate inside the collector to better indicate the temperature of the empty collector when the system is off for a period of time. In addition, the sensor at the bottom of the stratified solar tank, which was supposed to measure the collector supply temperature, was actually providing readings closer to the average tank temperature. The temperature sensors providing these readings have been relocated since the time of the test, and it appears that the system is now operating as intended.

Annual Energy Simulations

Appliances

Energy savings calculations for the appliances in both the Discovery House and the BA Benchmark are based on the 2005 version of an appliance analysis spreadsheet developed by NREL [7]. This spreadsheet performs energy-savings calculations using the energy-consumption data collected by the manufacturer in accordance with the DOE standard test procedures [8, 9, 10]. Usually these data can be found on the EnergyGuide label, the ENERGY STAR web site (www.energystar.gov/index.cfm?c=appliances.pr_appliances), the manufacturer's web site, or in the appliance database published by the California Energy Commission (www.energy.ca.gov/appliances/appliance). The NREL spreadsheet accepts published test results as inputs and calculates energy and hot-water consumption for the Prototype and Benchmark based on the standard Building America operating conditions and analysis guidelines [1, 11].

Energy savings predictions for the Discovery House clothes washer, clothes dryer, and dishwasher are provided in Table 3. The results suggest that substantial end-use energy savings can be expected for all three appliances. Electricity, natural gas, and hot water usage are all significantly less than the Benchmark values.

Table 3. Annual Energy Savings Calculations for Discovery House Appliances

Item	Dish-washer	Clothes Washer	Clothes Dryer
Benchmark Electricity (kWh/yr)	240	122	89
Discovery House Electricity (kWh/yr)	102	41	73
% Electricity Savings	58%	66%	18%
Benchmark Gas (kWht/yr)	N/A	N/A	1817
Discovery House Gas (kWht/yr)	N/A	N/A	850
% Gas Savings	N/A	N/A	53%
Benchmark DHW (liters/day)	22.0	66.2	N/A
Discovery House DHW (liters/day)	8.7	19.3	N/A
% DHW Savings	60%	71%	N/A

Solar Hot Water and Space Heating

TRNSYS simulations were performed to evaluate the contribution of solar energy toward meeting the DHW and space-heating loads. The heating coil in the air handler was designed to deliver the expected heating energy using a circulating water temperature of 43°C (110°F) or higher. If the temperature is lower, then the heat exchange rate at the coil may be too low to meet the load. The hydronic loop, on the other hand, can deliver heat at a lower temperature, perhaps 32°C (90°F). Because there is also a load on the storage tank to heat DHW, the tank will rarely reach 43°C (110°F) when space-heating is required. Therefore, only a small fraction of the space-heating load is likely to be met by solar energy.

Figures 10 and 11 show the predicted contribution of solar energy toward each end-use, based on the DHW volume and operating profile specified for Building America analysis [1]. Figure 10 shows the results for the system as installed, and Figure 11 shows the effect of reducing the minimum supply temperature for the hydronic floor slab to 32°C (90°F), and disconnecting the heating coil loop from the solar tank. In either case, the solar hot water system is expected to meet a very large percentage of the DHW load (83% as-built, 77% if modified), which for the purpose of this analysis includes both the energy to heat the mains water to the set point of 49°C (120°F) and the standby losses associated with the boiler tank. Based on our analysis, it appears that a greater fraction of the combined DHW and space-heating loads can be met by making the system modifications. We would expect the fraction of the basement space-heating load met by the solar system to increase from about 25% to nearly 56%. This would

represent an increase from 12% to 16% of the total space-heating load, and an increase from 28% to 30% of the combined DHW and space-heating loads.

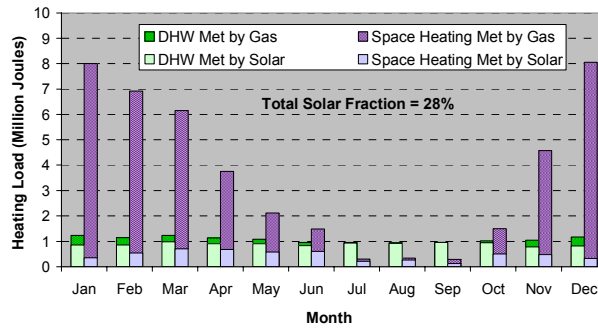

Figure 10. TRNSYS simulation results for the solar hot water system as currently implemented

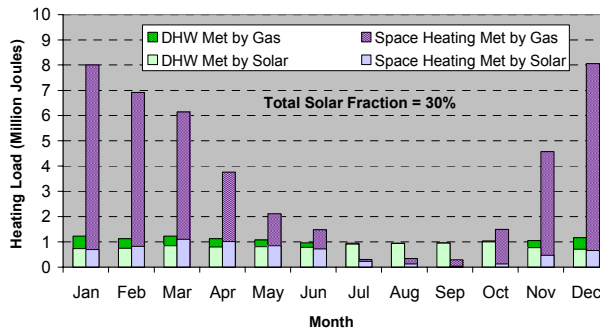

Figure 11. TRNSYS results if heating coil water does not run through the solar storage tank and the minimum supply temperature for the solar storage tank is set to 90°F (32°C)

Whole-House Energy Savings

A computer model of the Discovery House was created using the DOE-2.2 hourly simulation program. Inputs to the model were derived from the design specifications, short-term test results, TRNSYS simulations, and appliance spreadsheet calculations presented earlier in this paper. Simulations were performed in accordance with the BA Performance Analysis Procedures [11]. Graphical representations of the model generated using eQuest are shown in Figures 12 and 13.

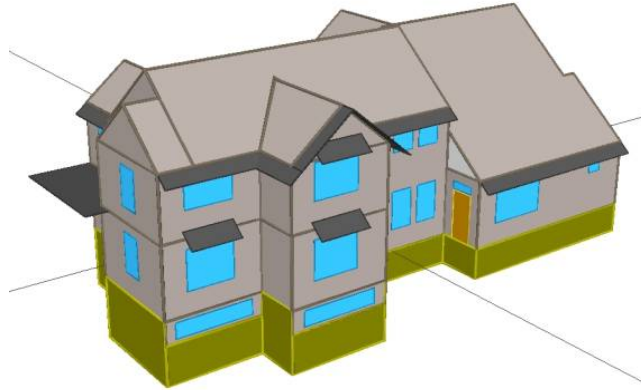

Figure 12. DOE-2 model geometry as viewed from the southwest, generated using eQuest



Figure 13. DOE-2 model geometry as viewed from the northeast with shading surfaces hidden, generated using eQuest

The Discovery House (identified in the following paragraphs as the Prototype) was compared to three base case houses: the BA Benchmark (representing typical practice in the 1990s), Regional Standard Practice, and Builder Standard Practice. The key features of these three base cases are summarized in Table 4.

Table 4. Summary of Model Inputs for the Discovery House and Three BA Base Cases

BA Benchmark

Frame walls, 2x4, R-2.5 m²·K/W (R-14 ft²·h·°F/Btu) cavity insulation, wood siding

R-5.8 m²·K/W (R-33 ft²·h·°F/Btu) ceiling insulation

Double-pane clear windows

Uninsulated vented crawlspace

R-1.8 m²·K/W (R-10 ft²·h·°F/Btu) basement walls

Infiltration rate = 0.65 ACH (annual average)

10 SEER 14 kW (4- ton) air-conditioner

78% AFUE forced-air furnace

151-liter (40-gal) Gas DHW, standard 0.54 EF

90% incandescent lighting

Standard appliances

Regional Standard Practice

Same as Benchmark except:

R-4.8 m²·K/W (R-27 ft²·h·°F/Btu) ceiling insulation

Uninsulated basement walls

Infiltration rate = 0.35 ACH (annual average)

Builder Standard Practice

Same as Regional Standard Practice except:

Frame walls, 2x6, 41 cm (16 in) oc, R-3.3 m²·K/W (R-19 ft²·h·°F/Btu) cavity insulation

R-6.7 m²·K/W (R-38 ft²·h·°F/Btu) ceiling insulation

Low-E, double-pane windows

Conditioned crawlspace and basement

R-0.9 m²·K/W (R-5 ft²·h·°F/Btu) insulated basement walls

Infiltration rate <0.35 ACH (annual average)

12-SEER air conditioner

92.1% AFUE furnace

Power-vented gas DHW, 0.58 EF

ENERGY STAR refrigerator and dishwasher

Builder Standard Practice and Regional Standard Practice were estimated based on inputs from McStain and our experience with other builders in central Colorado. The Prototype was modeled as designed (Table 1), except for infiltration, duct leakage, ventilation rate, and solar water heating efficiency, which were modeled based on measured performance. Although the stated efficiency of the prototype air conditioner was SEER 19, we modeled it as an effective SEER 16.5 based on discussions with BSC, an examination of the cooling system components, and published data from the manufacturer.

Source energy calculations sorted by end-use for the Discovery House prototype and base case houses are presented in Table 5. Source energy, or primary energy, is defined as the energy delivered to the house (site energy) plus the energy required for generation, transmission and distribution. Building America has chosen source energy as the primary metric for the calculation of energy savings because it includes important indirect energy uses that site energy does not. The national average site-to-source energy multiplier for electricity is about 3.16 and for natural gas is about 1.02 [11]. Table 5 indicates that energy for space cooling and DHW are nearly eliminated. Space heating and lighting are also significantly reduced, and there is a noticeable reduction in appliance energy. Total source energy savings for the Discovery House compared to the Benchmark is predicted to be 54%, significantly exceeding the design target of 40-50%.

Estimated energy and cost savings for packages of efficiency measures are shown in Table 6. Descriptions of the measures included in each package are listed in Table 7. The effect of each measure on end-use energy consumption is shown in Figure 14. A significant fraction of

the total savings is attributable to the quality of construction that McStain has already implemented, as indicated by the bar labeled “Builder Std.” Beyond McStain’s standard features, the most significant energy savings are associated with the high-efficiency boiler, efficient air distribution, solar hot water system, HRV, and compact fluorescent lighting package.

As often happens in a showcase home with many pieces of equipment that are donated or intended to be more educational than cost-effective, the Discovery house has a few redundant energy efficiency measures. Low solar heat gain windows, exterior shading, high-SEER air conditioner, whole-house fan, and thermostatically controlled windows are all measures that reduce summertime cooling energy for a house that already has limited cooling loads because of a tight building envelope, heat recovery ventilation, efficient lighting and appliances, and a climate with relatively few cooling degree days. NREL performed some additional simulations in an attempt to identify a more cost-effective package, but the effect of each measure on annual energy use was heavily dependent on the sequence in which the measures were ordered.

Table 5. Predicted Annual End-use Source Energy Consumption and Energy Savings for the McStain Discovery House

End-Use	Annual Source Energy				Annual Source Energy Savings					
	BA Bench kWh/yr	Region kWh/yr	Builder kWh/yr	Proto kWh/yr	Percent of End-Use			Percent of Total		
					BA Bench	Reg Base	Bldr Base	BA Bench	Reg Base	Bldr Base
Space Heating	53,932	38,303	33,554	20,881	61%	45%	38%	33%	22%	18%
Space Cooling	9,520	3,583	2,617	1,036	89%	71%	60%	8%	3%	2%
DHW	8,514	8,514	7,652	1,049	88%	88%	86%	7%	9%	9%
Lighting	8,517	8,517	8,517	3,407	60%	60%	60%	5%	6%	7%
Appliances + Plug	19,136	19,952	18,425	18,137	5%	9%	2%	1%	2%	0%
Ventilation	651	651	651	2,048	-214%	-214%	-214%	-1%	-2%	-2%
Total Usage	100,272	79,519	71,416	46,559	54%	41%	35%	54%	41%	35%
<i>Site Generation</i>	0	0	0	0				0%	0%	0%
<i>Net Energy Use</i>	100,272	79,519	71,416	46,559	54%	44%	35%	54%	41%	35%

Table 6. Predicted Annual Energy and Cost Savings for Major Energy Efficiency Measures

Increment	Annual Site Energy kWh/yr	Annual Source Energy		National Average Annual Energy Cost		Builder Standard (Local Costs)			
		kWh/yr	Savings	\$/yr	Savings	Annual Energy Cost \$/yr	Savings	Savings for Measure value (\$/yr)	Savings for Package savings (\$/yr)
BA Benchmark	65,658	100,357		\$2,828		\$2,516			
Regional Standard Practice	51,599	79,556	21%	\$2,244	21%	\$1,987			
Builder Standard Practice	45,943	71,459	29%	\$2,016	29%	\$1,778			
Improved Wall and Ceiling Insulation	43,583	68,387	32%	\$1,931	32%	\$1,695	5%	\$83	\$83
Basement Wall and Crawlspace Ceiling Insulation.	41,357	65,987	34%	\$1,865	34%	\$1,624	9%	\$71	\$154
Automatic Exterior Shading	41,477	66,026	34%	\$1,866	34%	\$1,627	9%	\$(3)	\$151
Automatic Natural Ventilation	41,855	66,196	34%	\$1,870	34%	\$1,635	8%	\$(9)	\$143
HRV	38,080	62,462	38%	\$1,769	37%	\$1,519	15%	\$116	\$259
Improved DHW	35,471	59,395	41%	\$1,684	40%	\$1,432	19%	\$87	\$346
Improved HVAC	31,000	53,679	47%	\$1,525	46%	\$1,277	28%	\$156	\$501
Improved Cooling	30,918	53,273	47%	\$1,513	47%	\$1,270	29%	\$7	\$508
Solar DHW and Space Heat	27,610	50,886	49%	\$1,451	49%	\$1,181	34%	\$89	\$597
Lighting and Appliance	26,889	46,633	54%	\$1,325	53%	\$1,109	38%	\$72	\$669

**Table 7. Descriptions of Energy Efficiency Measures included
in Each Step of the Analysis**

<i>Measure</i>	<i>Description</i>
BA Benchmark	Establishes the baseline energy use.
Regional Standard Practice	Regional Standard Practice models a building typical of the region
Builder Standard Practice	Builder Standard Practice models a building typical of this builder
Improved Wall and Ceiling Insulation	Walls improved to 2x6 with R-0.7 m ² ·K/W (R-4 ft ² ·h·°F/Btu) sheathing, Ceiling to R-7.7 m ² ·K/W (R-44 ft ² ·h·°F/Btu)
Basement Wall and Crawlspace Ceiling Insulation	Basement wall insulation increased to R-1.9 m ² ·K/W (R-11 ft ² ·h·°F/Btu) full length, Crawlspace Ceiling insulation to R-2.6 m ² ·K/W (R-15 ft ² ·h·°F/Btu)
Exterior Shading	Movable shading added
Automatic Natural Ventilation	Automatically ventilation added (windows)
HRV	70% Effective, 0.15 ACH HRV system
Improved DHW	DHW improved to a boiler with EF=0.86
Improved HVAC	Duct system 95% efficiency, electronically commutated fan motor, downsized 10.5-kW (3-ton) A/C
Improved Cooling	Improved cooling system (SEER 16.5)
Solar DHW & Space Heat	Active solar hot water system supplies heat to DHW and space heat
Lighting & Appliance	CFLs, Energy-Star appliances

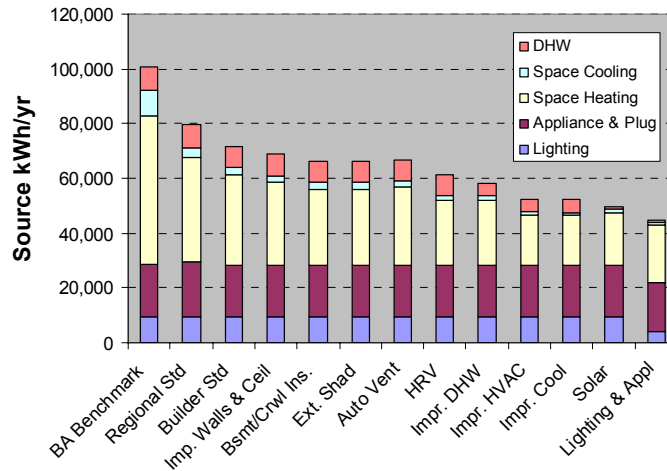

Figure 14. Influence of efficiency measures on end-use energy consumption

Other important considerations, including comfort, health and safety, durability, and physical appearance must also be factored into the trade-off analysis, along with energy and cost.

“Source Energy Savings %” and “National Average Energy Cost Savings %” are compared to the Building America Benchmark, whereas the “Local Energy Cost Savings %” and the “Package savings \$/yr” are compared to Builder Standard Practice.

National Average Electric Cost: 0.087 \$/kWh

National Average Gas Cost: 0.032 \$/kWht

Local Average Electric Cost: 0.059 \$/kWh

Local Average Gas Cost: 0.033 \$/kWht

Conclusions

Based on the test and analytical results discussed in the preceding sections, we were able to draw several conclusions about the Discovery House:

- The building envelope was very tight. Tracer-gas testing indicated about 0.02 to 0.05 ACH during mild summer weather. Blower-door tests conducted by BSC suggested an annual average infiltration of 0.16 ACH.
- Duct leakage to the outside was well within the design goal of 28 l/s (60 cfm) at 25 Pa, as measured by BSC using a duct blaster. Tracer-gas test results were consistent with duct-blaster measurements, indicating that duct leakage was less than 6 l/s (12 cfm) to the outside while the air handler was operating.
- Based on tracer-gas measurements, the HRV provided fresh air at a rate of about 35 l/s (75 cfm) when operating at low speed, consistent with the recommendations of ASHRAE Standard 62.2.
- The dishwasher, clothes washer, and clothes dryer each consumed significantly less energy than the BA Benchmark under normal operating conditions. However, certain operating modes, including the “sanitary” clothes washer cycle and the dishwasher power-dry option, used much more machine energy and/or hot water than other operating modes. The soil sensor in the dishwasher also dramatically increased energy use, while the weight sensor in the clothes washer significantly reduced energy use.
- The solar hot water system is expected to meet a large fraction of the DHW load (~83%), but only about 12% of the space-heating load. We recommended that the air handler heating coil loop be re-plumbed so that it is not allowed to circulate through the solar storage tank. The storage tank temperature setting could then be lowered to 32°C (90°F), and the basement hydronic loop could make greater use of the solar-heated water.
- DOE-2.2 simulations predict whole-house source energy savings of 54% compared to the BA Benchmark. The largest contributors to the energy savings (other than the efficiency improvements that are already standard practice for McStain) are the solar water heater, high-efficiency boiler, air-distribution improvements, HRV, and compact fluorescent lighting package.
- The measures designed to reduce cooling energy (including a high SEER air conditioner, exterior shading, low solar heat gain glass, heat recovery ventilation, tight envelope, automatic window control, and night ventilation) appear to be a bit redundant given the relatively mild summertime weather in Loveland. However, because the benefits of each measure are dependent on the order in which the measures are analyzed, it is difficult to say which are most cost-effective. Comfort, durability, and other considerations must also factor into the decision-making process when evaluating these features.

Acknowledgments

We express our appreciation to Justin Wilson, Jeff Medanich, and the rest of the team at McStain Neighborhoods for providing NREL with extensive field support, including generous access to the Discovery House during and after the test period. We would also like to acknowledge the hard work of the BSC team in assisting with the design of the Discovery House and offering their insights throughout the test and analysis phase of the project. Finally, we want to thank Ed Pollock and George James of DOE for the leadership and resources necessary to perform this work.

References

- [1] Hendron, R. 2005. Building America Research Benchmark Definition, Updated December 29, 2004. NREL Report No. 37529, Golden, CO: National Renewable Energy Laboratory.
- [2] McStain Neighborhoods. 2004. The McStain Discovery House Breaks Ground! Louisville, CO.
- [3] Balcomb, J., Burch, J., Subbarao, K. 1993. Short Term Energy Monitoring of Residences. ASHRAE Transactions, DE-93-14-3, Atlanta, GA.
- [4] Hancock, E., Norton, P., Hendron, R. 2002. Building System Performance Test Practices: Part 2, Air-Exchange Measurements. NREL Report No. TP-550-30270, Golden, CO: National Renewable Energy Laboratory
- [5] Bou-Saada, T., Haberl, J. 1995. An Improved Procedure for Developing Calibrated Hourly Simulation Models, Proceedings of Building Simulation '95, pp. 475-484, College Station, TX: Texas A&M University.
- [6] Norton, P., Hancock, E., Barker, G., Reeves, P. 2005. "Solar Patriot" House: A Case Study in Efficiency and Renewable Energy. NREL Report No. TP-550-37731, Golden, CO: National Renewable Energy Laboratory.
- [7] Eastment, M., Hendron, R. In Preparation. Method for Evaluating Energy Use of Dishwashers, Clotheswashers and Clothes Dryers Based on DOE Test Procedures. Draft NREL Technical Report TP-550-39454, Golden, CO: National Renewable Energy Laboratory.
- [8] U.S. Department of Energy (DOE). 2001. Code of Federal Regulations Title 10, Part 430, Subpart B, Appendix J – Uniform Test Method for Measuring the Energy Consumption of Automatic and Semi-automatic Clothes Washers, DOE, Washington, DC.
- [9] U.S. Department of Energy (DOE). 1981. Code of Federal Regulations Title 10, Part 430, Subpart B, Appendix D – Uniform Test Method for Measuring Energy Consumption of Clothes Dryers, DOE, Washington, DC.
- [10] U.S. Department of Energy (DOE). 2003. Code of Federal Regulations Title 10, Part 430, Subpart B, Appendix C – Uniform Test Method for Measuring Energy Consumption of Dishwashers, DOE, Washington, DC.
- [11] Hendron, R., Anderson, R., Judkoff, R., Christensen, C., Eastment, M., Norton, P., Reeves, P., Hancock, E. 2004. Building America Performance Analysis Procedures: Revision 1. NREL Report No. TP-550-35567, Golden, CO: National Renewable Energy Laboratory.

REPORT DOCUMENTATION PAGE

Form Approved
OMB No. 0704-0188

The public reporting burden for this collection of information is estimated to average 1 hour per response, including the time for reviewing instructions, searching existing data sources, gathering and maintaining the data needed, and completing and reviewing the collection of information. Send comments regarding this burden estimate or any other aspect of this collection of information, including suggestions for reducing the burden, to Department of Defense, Executive Services and Communications Directorate (0704-0188). Respondents should be aware that notwithstanding any other provision of law, no person shall be subject to any penalty for failing to comply with a collection of information if it does not display a currently valid OMB control number.

PLEASE DO NOT RETURN YOUR FORM TO THE ABOVE ORGANIZATION.

1. REPORT DATE (DD-MM-YYYY) August 2006		2. REPORT TYPE Journal Article		3. DATES COVERED (From - To)	
4. TITLE AND SUBTITLE Evaluation of a High-Performance Solar Home in Loveland, Colorado: Preprint				5a. CONTRACT NUMBER DE-AC36-99-GO10337	
				5b. GRANT NUMBER	
				5c. PROGRAM ELEMENT NUMBER	
6. AUTHOR(S) R. Hendron and M. Eastment: NREL E. Hancock and G. Barker: Mountain Energy Partnership P. Reeves: Partnership for Resource Conservation				5d. PROJECT NUMBER NREL/JA-550-40374	
				5e. TASK NUMBER BET6.8004	
				5f. WORK UNIT NUMBER	
7. PERFORMING ORGANIZATION NAME(S) AND ADDRESS(ES) National Renewable Energy Laboratory 1617 Cole Blvd. Golden, CO 80401-3393				8. PERFORMING ORGANIZATION REPORT NUMBER NREL/JA-550-40374	
9. SPONSORING/MONITORING AGENCY NAME(S) AND ADDRESS(ES)				10. SPONSOR/MONITOR'S ACRONYM(S) NREL	
				11. SPONSORING/MONITORING AGENCY REPORT NUMBER	
12. DISTRIBUTION AVAILABILITY STATEMENT National Technical Information Service U.S. Department of Commerce 5285 Port Royal Road Springfield, VA 22161					
13. SUPPLEMENTARY NOTES					
14. ABSTRACT (Maximum 200 Words) Building America (BA) partner McStain Neighborhoods built the Discovery House in Loveland, Colorado, with an extensive package of energy-efficient features, including a high-performance envelope, efficient mechanical systems, a solar water heater integrated with the space-heating system, a heat-recovery ventilator (HRV), and ENERGY STAR appliances. The National Renewable Energy Laboratory (NREL) and Building Science Consortium (BSC) conducted short-term field-testing and building energy simulations to evaluate the performance of the house. These evaluations are utilized by BA to improve future prototype designs and to identify critical research needs. The Discovery House building envelope and ducts were very tight under normal operating conditions. The HRV provided fresh air at a rate of about 35 l/s (75 cfm), consistent with the recommendations of ASHRAE Standard 62.2. The solar hot water system is expected to meet the bulk of the domestic hot water (DHW) load (>83%), but only about 12% of the space-heating load. DOE-2.2 simulations predict whole-house source energy savings of 54% compared to the BA Benchmark. The largest contributors to energy savings beyond McStain's standard practice are the solar water heater, HRV, improved air distribution, high-efficiency boiler, and compact fluorescent lighting package.					
15. SUBJECT TERMS Building America; U.S. Department of Energy; Discovery House; residential homes; energy efficient homes; high-performance envelope; National Renewable Energy Laboratory; solar water heater; heat-recovery ventilator					
16. SECURITY CLASSIFICATION OF:			17. LIMITATION OF ABSTRACT UL	18. NUMBER OF PAGES	19a. NAME OF RESPONSIBLE PERSON
a. REPORT Unclassified	b. ABSTRACT Unclassified	c. THIS PAGE Unclassified			19b. TELEPHONE NUMBER (Include area code)