

ULTRA-FAST PUMP-PROBE DETECTION USING PLASMAS*

R. Tatchyn[#], SSRL, Stanford, CA 94305, U.S.A.

Abstract

The temporal resolution of pump-flash interactions in the femtosecond-attosecond (fs-as) regime is limited by the characteristic time constants of the excited states in the detector material. If the relaxation time constant is appreciably longer than the time interval between the pump and probe signals the response of the detector material to the probe represents a temporal convolution with the pump and probe responses, setting a lower limit on the resolution to which the interval between the two pulses can be measured. In most of the solid state ultrafast detection schemes that are being considered for the ultra-short pulse x-ray sources under current development at SLAC and elsewhere the characteristic time constants are related to the bound states of the atoms comprising the material or to the relaxation times of phase transitions or charge carrier populations of the lattice, setting a probable lower limit on the attainable resolution on the order of ~ 0.1 ps. In this paper we consider a novel detection principle based on the excitation of specially prepared unbound states in an ionized plasma with high pump and probe fields, and estimate its potential for extending the lower limit of resolution into the attosecond (as) regime.

INTRODUCTION

A significant number of the upcoming or proposed 4th generation synchrotron radiation (SR) sources will be based on linac driven Ångstrom-wavelength Free Electron Lasers (FELs) operating in the Self-Amplified Spontaneous Emission (SASE) [1,2,3] regime. Some of the singular aspects of such sources include extraordinarily high peak powers (>10 GW), sub-picosecond pulse lengths, and a high degree of transverse coherence. These three parameters, in particular, are expected to enable scientific experiments heretofore inaccessible with earlier-generation SR sources. One important category of experiment will be of the "pump-probe" class, i.e., a precursor pulse (the pump) will be used to alter or perturb the state parameters of an experimental sample from their equilibrium values and a probe pulse (from the X-ray FEL) will be used to characterize the perturbed state. Clearly, with both pump and probe in the sub-picosecond range, the study of ultra-fast processes is enabled, and this in turn provides the motivation for developing ultra-fast detectors that can not only measure the pulse lengths themselves, but that can also determine the interval between the arrival times of the two pulses to a resolution significantly shorter than the characteristic time constants of the processes being studied.

* Work supported by Department of Energy Contract DE-AC02-76SF00515 and Department of Energy CRADA SLAC-9302.

[#] tatchyn@ssrl.slac.stanford.edu

To date, many schemes have been attempted or proposed for measuring the interval between ultra short pump and probe pulses (see, e.g., [4,5]). A majority of these have been based on the pump excitation of some selected ultra fast process in, typically, a solid state sample (bulk or surface) and its detection by the probe pulse. The scattered signal indicates whether or not the probe pulse is passing through a region that is being (or has been) irradiated by the pump, i.e., it gives information on the coincidence or non-coincidence of the two pulses. Clearly, the ideal circumstance would be for the detector material to be perturbed only while the pump field was actually present, as this (and only this) would unambiguously signal the (space-time) coincidence or non-coincidence of the pump and probe. However, a consideration of the techniques heretofore employed reveals that the practical limit on the temporal resolution of pump-flash interaction measurements is determined not only by the finite excitation (or activation) time constants of the detector material but also by the characteristic relaxation times of its excited states (see Fig. 1).

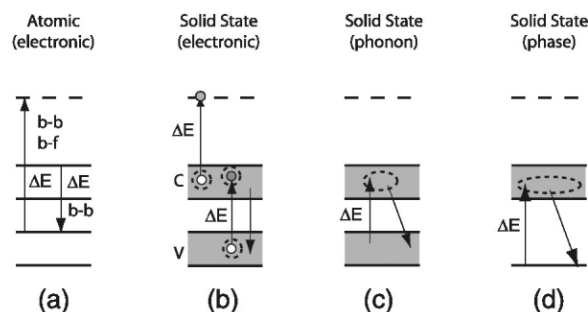

Figure 1: Various classes of excitation and relaxation processes in detector materials with activation energies ΔE (a) Atomic transitions: b-b (bound-bound); b-f (bound-free), Relaxation processes include fluorescence, Auger, etc. (b) Solid state electronic transitions (conductor, semiconductor); V-valence; C-conduction. (c) Solid state phonon transitions. (d) Solid state phase transitions. Dashed ovals denote equilibration or relaxation processes

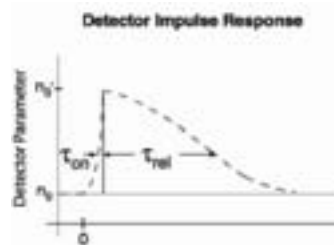

Figure 2: Temporal response of detector material to a pump impulse. The pump pulse modulates the physical parameter n_0 .

If the sum of the activation and relaxation time constants, $\tau_{\text{on}} + \tau_{\text{rel}}$ (see Fig. 2), is appreciably longer than the time interval between the pump and probe signals the response of the detector material to the probe will reflect its temporal convolution with both the pump and probe responses, necessitating model-dependent deconvolution of data to estimate the actual interval between the two pulses. In most cases this sets a lower limit on the resolution to which the interpulse interval can be reliably measured. In most of the solid state ultrafast detection schemes that are being considered or investigated for the ultra-short pulse x-ray sources under current development at SLAC and elsewhere the characteristic time constants are related to the bound state lifetimes of the atoms comprising the material or to the relaxation times of phase transitions or charge carrier populations of the lattice. The former govern the activation times (and also portions of the relaxation times) through the uncertainty principle (viz., $\Delta E \Delta t > \hbar/2$; $\tau_{\text{on}} > \hbar/2\Delta E$), while the latter, depending on the number and complexity of the processes involved, determine the relaxation durations τ_{rel} . In practical terms, both theoretical calculations and experimental work done to date indicate a probable lower limit on the attainable resolution in most cases on the order of ~ 0.1 ps [6,7]. In the following sections of this paper we consider a novel detection principle predicated on the excitation of specially prepared unbound states in an ionized plasma which feature virtually instantaneous activation and relaxation times. A cross-correlation (pulse coincidence) detector based on the activation of these states will be described and analyzed and the conditions for its potential use for extending the lower limit of resolution into the as regime will be considered. It will be shown that the method will require operation with high pump and probe fields, with equivalent powers in the GW-TW range.

ULTRA FAST CROSS CORRELATOR: CONFIGURATION

A schematized layout of the ultra fast detector is shown in Fig. 3.

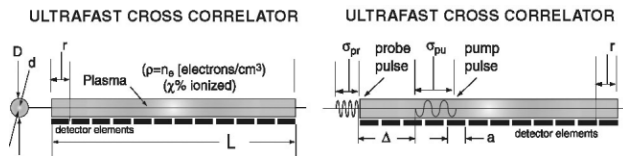

Figure 3: Ultra fast cross correlator. Pump-probe pulse coincidence is achieved via the difference in group velocities v_{pu} vs. v_{pr} . The pump modulates the Lorentz factor γ of the electrons. The Rayleigh waist diameters of the pump and probe pulses are both designated by d .

The detector material is a highly ionized plasma ($\chi\%$ ionization) with electron density $\rho = n_e [\text{cm}^{-3}]$ contained in a cylindrical cell. In operation a pump pulse with field intensity E , length σ_{pu} , angular frequency ω_1 , diameter d ,

and group velocity v_{pu} , is propagated along the axis of the cell. In the discussion to follow this pulse will be assumed to be 100% circularly polarized. The desired modulation effect is the acceleration of the plasma electrons to (constant) elevated speeds for which the electrons' Lorentz factor γ will deviate appreciably from 1. The probe pulse, of frequency ω_2 , is then sent along the cell axis with group velocity v_{pr} , where $v_{\text{pr}} > v_{\text{pu}}$. When the probe pulse, of length $\sigma_{\text{pr}} < \sigma_{\text{pu}}$, is coincident with the pump pulse its scattering off the relativistic electrons, registered by independent detector elements distributed coaxially with the cell axis, will differ from that of the electrons outside the pump probe volume.

ULTRA FAST CROSS CORRELATOR: ANALYSIS

To facilitate the analysis the basic parameters of the system are listed in Table 1. Unless otherwise noted the parameters are to be quantified in MKS units.

Table 1: Ultra fast cross correlator parameters.

Differential velocity cell length	L	[m]
Detector element length	a	[m]
Cell plasma ionization	χ	%
Plasma electron density	n_e	$[\text{cm}^{-3}]$
Resolution increment	ℓ_r	[m]
Pump pulse field	E	[V/m]
Pump pulse length	σ_{pu}	[m]
Pump pulse angular frequency	ω_1	[rad/s]
Pump pulse group velocity	v_{pu}	[m/s]
Probe pulse field	E_{pr}	[V/m]
Probe pulse length	σ_{pr}	[m]
Probe pulse angular frequency	ω_2	[rad/s]
Probe pulse group velocity	v_{pr}	[m/s]
Probe photons emitted in unpumped length ℓ_r	N_1	ph
Probe photons emitted in pumped length ℓ_r	N_2	ph

The response of the x and y motions of the plasma electrons to the circularly polarized pump field is described by the Lorentz force equation [8] where m_e is the electron mass, v_x and v_y are the transverse velocity components of the electrons, q is the electronic charge, and γ is the Lorentz factor, viz.:

$$\frac{d(\gamma m_e v_x)}{dt} = -qE \cos \omega_1 t; \quad \frac{d(\gamma m_e v_y)}{dt} = -qE \sin \omega_1 t, \quad (1)$$

The solution,

$$v_x = -\frac{qE}{m_e \gamma \omega_1} \sin \omega_1 t; \quad v_y = \frac{qE}{m_e \gamma \omega_1} \cos \omega_1 t, \quad (2)$$

yields

$$\gamma^2 = \frac{1}{1 - ((v_x^2 + v_y^2)/c^2)} = 1 + \frac{qE^2}{m_e c \omega_1^2}, \quad (3)$$

indicating that the pump pulse induces a constant inertial mass increase on the free electrons it interacts with.

An approximation to the (signal) power scattered out of the probe pulse (also assumed circularly polarized) by the

plasma electrons is given by substituting eq. (1) into the formula for total power radiated by an electron ([8], op. cit., pp.702-703), yielding

$$P_{sig}[W/el] = \frac{2}{3} \frac{q^2}{4\pi\epsilon_0 c^3} \langle \dot{v}_{xpr}^2 + \dot{v}_{ypr}^2 \rangle = \frac{1}{6\pi\epsilon_0 c} \left(\frac{q^2 E_{pr}}{m_e c \gamma} \right)^2, \quad (4)$$

where ϵ_0 is the permittivity of free space and c is the velocity of light. Here we have assumed that $\omega_1 \ll \omega_2$ and the probe-induced motions are superimposed linearly on those induced by the pump. In numerical terms, the probe power scattered per electron for $\gamma \sim 1$ is just:

$$P_{sig}[W/el] \cong 1.76 \times 10^{-31} \frac{E_{pr}^2}{\gamma^2} \cong 1.76 \times 10^{-31} E_{pr}^2. \quad (5)$$

Taking the entire probe pulse into account, the number of photons scattered in a unit of length equal to σ_{pr} is

$$N_{ph} \cong P_{sig}[W/el] \times \frac{n_e \pi^2 d^2 \sigma_{pr}^2}{2v_{pr} h \omega_2} = \frac{\pi n_e}{12\epsilon_0 c v_{pr} h \omega_2} \frac{q^2 d \sigma_{pr} E_{pr}^2}{m_e c \gamma}, \quad (6)$$

where h is Planck's constant. In numerical terms,

$$N_{ph} \cong 4.59 \times 10^{-6} \frac{n_e}{\omega_2} (d \sigma_{pr} E_{pr})^2 \cong 4.49 \times 10^3 \frac{n_e}{\omega_2} \sigma_{pr}^2 P_{pr}. \quad (7)$$

Using equ's. (3) and (4), we now define a "contrast factor" η_c , which denotes the relative difference in probe power scattered by the pump-excited vs. non-excited electrons, viz.:

$$\eta_c = \frac{P_{sig(nopump)}[W/el] - P_{sig(pump)}[W/el]}{P_{sig(nopump)}[W/el]} = \frac{qE}{m_e c \omega_1}^2 \left(1 + \frac{qE}{m_e c \omega_1} \right)^{-1}. \quad (8)$$

This factor is plotted in Fig. 4 to show its dependence on practical laser parameters. It is evident that values in the >0.01 range imply the use of pump lasers in the GW-TW class range.

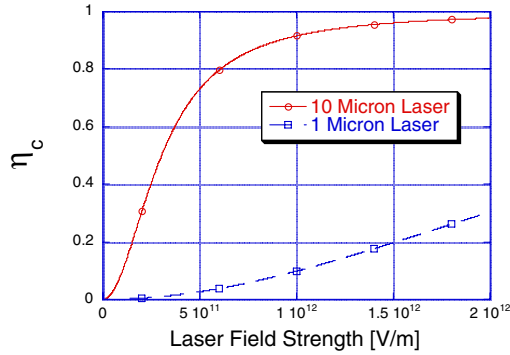

Figure 4: Dependence of the relative relativistic mass modulation η_c of electrons on laser wavelength and field strength.

Setting the condition that the difference in photon counts N_2 and N_1 detected for these two types of scattering should be equal to the sum of their standard deviations, viz., $\sqrt{N_2} + \sqrt{N_1} = \eta_c N_1$, leads to the following approximation for ℓ_r , the minimum resolution increment along the cell's longitudinal dimension:

$$\ell_r \cong 7.87 \times 10^{-21} \frac{\omega_2 \omega_1^4 d^4}{n_e \sigma_{pr} P_{pr} P_{pu}^2}, \quad (9)$$

where P_{pu} and P_{pr} are, respectively, the powers of the pump and probe pulses. For practical devices, $d < \ell_r < 1\text{cm}$.

This parameter indicates how many of its own lengths the probe pulse has to travel before generating a statistically useful number of photons. In this regard, it determines the difference in the group velocities of the pump vs. probe pulses needed to dilate the effective interaction time between them by the same factor and it can also be used to provide an estimate for Δ , the length of the individual detector elements.

In operation, upon entering the cell the pump and probe pulses will each reduce their group velocity from c to, respectively, v_{pu} and v_{pr} . If the rear-front distance between the pulses at the entrance to the cell (i.e., with the front of the second pulse just entering the cell) is designated by Δ , the pulses will start to intersect in a time τ_1 given by:

$$\tau_1 = \frac{\Delta}{v_{pr} - v_{pu}}. \quad (10)$$

The pulses will pass through each other in a distance ℓ_1 given by:

$$\ell_1 = \frac{v_{pr} \sigma_{pu} + \sigma_{pr} v_{pu}}{v_{pr} - v_{pu}}, \quad (11)$$

and the minimal length of the cell will then be approximately defined by the quantity

$$L \geq \Delta + \tau_1 v_{pu} + \frac{v_{pr} \sigma_{pu} + \sigma_{pr} v_{pu}}{v_{pr} - v_{pu}}. \quad (12)$$

KINETIC EFFECTS

It is of interest to calculate the radius of electron motion, r_{pu} , in the pump field. From equ's. (1)-(2) we obtain

$$r_{pu} = \frac{qE}{m_e \gamma \omega_1^2}. \quad (13)$$

To first order, this quantity should be smaller than the mean free path of the electrons, ℓ_{e-i} , in the plasma, viz.,

$$r_{pu} \leq \ell_{e-i} \cong \frac{1}{\sqrt{2\pi} r_{pu} d_i n_e}. \quad (14)$$

In order for the equations (1)-(9) describing the performance and parameters of the cross correlator to remain valid, it is necessary for a majority of the electrons in the volume of the probe field to maintain their circular motion (i.e., to experience no collisions) as the probe pulse passes through that volume. If criterion (14) is met, this means that the average number of ion-electron collisions in that volume during that time interval should be a sufficiently small fraction, η_{coll} , of the total number of electrons in that volume. This leads to the following criterion:

$$\frac{2\pi r_{pu} d_i n_e \sigma_{pr}}{c} \sqrt{\frac{kT}{m_e}} = 7.78 \times 10^{-20} r_{pu} d_i n_e \sigma_{pr} \sqrt{\frac{T}{m_e}} \leq \eta_{coll}, \quad (15)$$

where d_i is the ion diameter and T is the electron drift temperature in K. Its magnitude is clearly sensitive to the ionic diameter and indicates that with a $Z > 1$ -plasma a recalculation of the criterion for each species of ion taking into account its relative concentration should be performed. Nevertheless, simple estimates for $Z=1$

indicate that at the sub-picosecond regimes of both the pump and probe pulses and an ionization of ~100% the criterion should be readily fulfillable (with $\eta_{\text{coll}} \sim 0$) for electron densities as high as $\sim 10^{19} \text{ cm}^{-3}$. If (14) is not satisfied (this would apply to electron densities in excess of 10^{19} cm^{-3} and fields in excess of $\sim 1 \text{ TV/m}$) the effect of collisions in lowering the efficiency of the pump field excitation would need to be reanalyzed in more exact detail.

DISCUSSION

We have described an ultra fast cross correlator based on a novel principle of modulation: an induced deviation in the relativistic mass of electrons in an ionized lab frame plasma by a GW-TW pump laser field. Since the process can be centered to a large degree on free-free transitions, it exhibits no hysteresis, or “memory,” certainly not down to time scales at most of the order of 10^{-18} s , providing an instantaneous “signature” when – and only when – the pump and probe pulses are in exact space-time coincidence. Eq. (9) contains the basic parameters that define the design constraints and expected performance levels for the proposed device. It also points to a number of the conditions that need to be satisfied by the remaining physical parameters and constituents of the system. Perhaps the most important one of these is the selection of the appropriate gas, its density, and the degree of ionization χ required to operate the cell with a given short wavelength FEL source. To this end, the plasma parameters must be selected so that the pump and probe pulses each develop the appropriate group velocity along the cell axis. Concurrently, the temporal dispersion must also be controlled to prevent overly severe lengthening of either pulse while they are interacting inside the cell. In this regard, we note that the index of refraction seen by each pulse must be appropriately designed. If the gas is fully ionized ($\chi=100\%$), the primary absorption mechanism for each pulse will be inverse bremsstrahlung, with an associated absorption constant given by

$$\alpha(\lambda, T) [\text{cm}^{-1}] = 1.272 \times 10^{-38} Z^2 n_e n_i \lambda^3 \times \frac{(e^{1.24/\lambda T} - 1)g(Z^2 \lambda, T / Z^2)}{\sqrt{T(1 - 8.97 \times 10^{-22} n_e \lambda^2)}} \quad (16)$$

where n_e and n_i are the electron and ion numbers per cubic cm, λ is the laser wavelength in μm , T is the plasma temperature in K, and g is the Gaunt factor [9], whose numerical value should remain of the order of 10 for probably the majority of plasma conditions appropriate to cell operation. If the group velocities cannot be suitably adjusted for a fully ionized plasma then lowering the degree of ionization could be used to activate atomic (bound state) absorptive and elastic scattering transitions and these can then be used as additional degrees of freedom to help tailor the group velocity and dispersion characteristics of each pulse toward appropriate values.

A number of additional factors that represent potential sources of systematic error must be kept in mind in the design and operation of a given cell. Perhaps the two most

important ones involve gas density and ionization. In the first case moving to pressures above the Knudsen regime (0.01-1 Torr) could – depending on the type and operating mode of ionization – lead to turbulent flow and other bulk motion effects that could impact the homogeneity or symmetry of the medium. It could also impact non-linear or other high field effects such as, e.g., self-focusing [10]. Regarding the ionization, the use of relatively high densities (along with the specific value of D) could imply large amounts of power for sustained $\chi=100\%$ operation. To this end, ionizing the cell in a pulsed mode could be advantageous, particularly in view of the pulsed time structure of the sources for which it is intended. However, the specific mechanism of ionization is also critical, as care must be taken to minimize acceleration of the plasma species to energies at or above the photon energy of the probe pulse.

In summary, the proposed cross correlator is without question appropriate exclusively to ultra high power short-pulse pump lasers and radiation probes – it has little chance of working well at sub-GW power levels. On the other hand, it provides a unique metrological capability for the developing class of ultra high power, ultra short pulse FELs, whose availability will in all likelihood stimulate new and important classes of pump-probe experiments that would stand to benefit from measurement capabilities with resolutions comparable to that of our proposed technique.

REFERENCES

- [1] K.-J. Kim, "Three Dimensional Analysis of Coherent Amplification and Self-Amplified Spontaneous Emission in Free-Electron Lasers," *Phys. Rev. Lett.* 57(13), 1871(1986).
- [2] J. Arthur et al., "Linac coherent light source (LCLS) conceptual design report," SLAC-R-593; UC-414; 2002; <http://www-ssrl.slac.stanford.edu/lcls/cdr/>
- [3] TESLA Technical Design Report, DESY Report No. 2001-11, DESY, Hamburg, Germany, 2002.
- [4] B.W. Adams, "Manipulation and detection of X-rays on the femtosecond time scale (invited)," *Review of Scientific Instruments*, 73(3), 1632-6(2002).
- [5] B.W. Adams, "Femtosecond coherent control of x-rays," *SPIE Proceedings* 5194, no.1, 46-55(2004).
- [6] K.J. Gaffney, "Ultrafast x-ray studies of structural dynamics at SLAC," *SPIE Proceedings* 5971, pp 19070D-1/9.
- [7] A.L. Cavalieri et al., "Clocking femtosecond x-rays," *Phys. Rev. Lett.* 94, 114801 (2005).
- [8] P. Lorrain, D.R. Corson, F. Lorrain, *Electromagnetic Fields and Waves*, W. H. Freeman and Company, New York, 1988, p. 293 ff.
- [9] J.K. Stallcop, K.W. Billman, "Analytical formulae for the inverse bremsstrahlung absorption coefficient," *Plasma Physics* 16, 1187-1189(1974).
- [10] J.F. Reintjes, "Nonlinear Optical Processes," in *Encyclopedia of Physical Science and Technology*, Vol. II, pp. 49-102, Academic Press.