

Melter Dismantlement

Bradley S. Richardson

Oak Ridge National Laboratory

Contents

INTRODUCTION	1
DESCRIPTION OF MELTERS	1
WEST VALLEY DEMONSTRATION PROJECT	1
DEFENSE WASTE PROCESSING FACILITY.....	3
PAMELA.....	5
D&D EXPERIENCE.....	7
PAMELA.....	7
IDMS	9
OTHER RELEVANT LARGE SCALE D&D OPERATIONS	10
<i>Chicago-Pile No. 5 (CP-5) D&D.....</i>	<i>10</i>
<i>Modified Brokk Demolition Machine with Remote Console.....</i>	<i>12</i>
COMMERCIAL CAPABILITIES	14
KEIBLER-THOMPSON	14
BROKK.....	15
TOOLING	16
REMOTE CUTTING	16
GLASS REMOVAL.....	17
CP-5 EXPERIENCE	18
DISPENSATION OPTIONS	19
REFURBISHMENT	20
LONG-TERM STORAGE	20
COMPLETE D&D	21
CONCLUSIONS.....	22
REFERENCES	23

Figures

FIG. 1. WVDP SFCM SECTION.....	2
FIG. 2. IDMS MELTER SECTION.....	3
FIG. 3. DWPF MELTER SECTION.	4
FIG. 4. DWPF MELTER ASSEMBLY AND INSTALLATION.	5
FIG. 5. PAMELA VITRIFICATION PLANT.	5
FIG. 6. CROSS SECTION OF THE PAMELA MELTER.	6
FIG. 7. MELTER CELL SCHEMATIC.	8
FIG. 8. SCHEMATIC OF THE CP-5 RESEARCH REACTOR.	11
FIG. 9. DAWP WORKING ABOVE THE CP-5 RESEARCH REACTOR.....	11
FIG. 10. MODIFIED BROKK PERFORMING FACILITY D&D TASK.	13
FIG. 11. COMPACT CONSOLE CONTROLLING THE MODIFIED BROKK.	14
FIG. 12. KEIBLER-THOMPSON REMOTE SYSTEMS.....	15
FIG. 13. BROKK REMOTE CONTROLLED SYSTEM PERFORMING D&D TASKS.....	16

Tables

TABLE 1. DWPF MELTER COMPONENTS.....	4
TABLE 2. BASIC MELTER PARAMETERS.....	7
TABLE 3. MELTER DISMANTLING SEQUENCE.....	8
TABLE 4. CUTTING RATES FOR STAINLESS STEEL.....	9
TABLE 5. LESSONS LEARNED FROM DISMANTLING OF PAMELA MELTER.....	9
TABLE 6. REFURBISHMENT ISSUES.	20

Melter Glass Removal Methods

Introduction

The U.S. Department of Energy (DOE) has been utilizing vitrification processes to convert high-level radioactive waste forms into a stable glass for disposal in waste repositories. Vitrification facilities at the Savannah River Site (SRS) and at the West Valley Demonstration Project (WVDP) are converting liquid high level waste (HLW) by combining it with a glass-forming media to form a borosilicate glass, which will ensure safe long-term storage. Large, slurry fed melters, which are utilized for this process, were anticipated to have a finite life, on the order of two to three years, at which time they would have to be replaced using remote methods, due to the high radiation fields. In actuality the melters useable life span has, to date, have exceeded original life span estimates.

Initial plans called for the removal of failed melters by placing the melter assembly into a container and storing in a concrete vault on the vitrification plant site pending size reduction, segregation, containerization, and shipment to appropriate storage facilities. Separate facilities for the processing of the failed melters currently do not exist. Options for handling these melters include 1) locating a facility to conduct the size reduction, characterization, and containerization as originally planned; 2) long-term storage or disposal of the complete melter assembly; and 3) attempting to refurbish the melter and to reuse the melter assembly.

The focus of this report is to look at methods and issues pertinent to size reduction and/or melter refurbishment. In particular, removal of glass as a part of a refurbishment or for the purposes of reducing contamination levels (allowing for disposal of a greater proportion of the melter as low level waste) will be addressed.

Description of Melters

A brief description of the two melters being operated in the U.S. and the Pamela melter operated in Belgium follows.

West Valley Demonstration Project

A Functional and Checkout Testing of Systems (FACTS) program to test new equipment and processes was conducted from 1984 to 1989. While a detailed description of the FACTS testing can be found in (Carl, 1990) and the disassembly results in (Brooks, 1995), only a brief summary relevant to the purposes of this report are included here.

In the FACTS testing, a slurry-fed ceramic melter (SFCM) similar to the one currently in operation was used to make 150,000 kg of glass using materials to simulate radioactive waste. The SFCM used during the FACTS testing, (Fig. 1) is shaped like an inverted prism with the vessel walls sloped inward toward the bottom. The melter has three electrodes, two in the sides of the vessel and one in the floor at the base of the inverted prism. Normal glass inventory

during operations was 0.86 m³. Weight, while full of glass was approximately 47,200 kg. The shape of the melter was selected in part to minimize inventory in the melter in the event of a system failure. The melter is encased inside a water-cooled-jacket. Interior surfaces of the box are made from Inconel[®] 690 for corrosion resistance. The exterior of the water-cooled-jacket is made from 304 stainless steel.

Drainage of the molten glass was conducted using an “airlift” mechanism, which introduced air bubbles into the discharge passage to raise the level of the melt causing it to flow out in an intermittent rather than continuous flow. Complete draining, was performed twice using an evacuated canister suction technique following the “airlift” method. Both times, approximately 95% of the glass was removed from the melter.

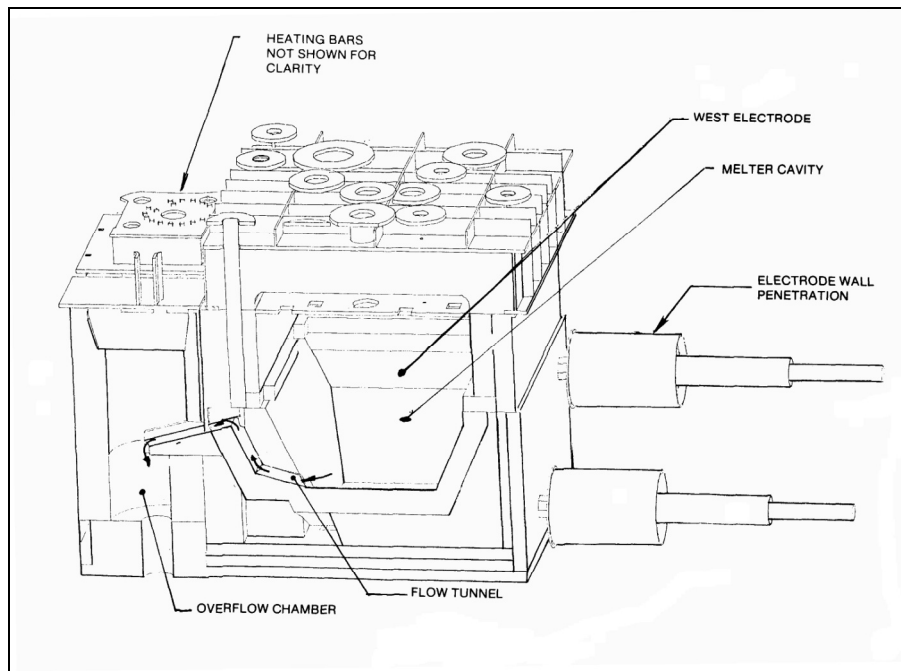

Fig. 1. WVDP SFCM Section.
(Chapman, 1988)

The SFCM used for the HLW processing is similar to the melter used in the FACTS testing. A summary description is provided here, while a more detailed description can be found in (Vance, 1997). The melter is a 3.05m x 3.05m x 3.05m (10ft x 10ft x 10ft) cube and weighs approximately 48,100 kg. The melter cavity accommodates 0.86 m³ of molten glass during normal operations. The melter is supported by painted carbon steel structure that is bolted to the floor. This melter has been processing HLW since 1996 with more than 95% of the HLW vitrified.

Defense Waste Processing Facility

The Defense Waste Processing Facility (DWPF) is located at the DOE's SRS and has been processing HLW since 1996. Prior to that, a 1/10 pilot scale melter, the Integrated DWPF Melter System (IDMS) melter (Fig. 2) was operated continuously for seven years at 1150°C (Jantzen, 1999). The IDMS was used to process simulated waste glasses from 1988 until it was shut down in 1995 so that it could be inspected to form a baseline for determining the requirements for future inspections of the DWPF melter and off-gas piping. Upon completion of the IDMS operations, the melter was inspected and data gathered on system wear and the composition of deposits remaining in the melter.

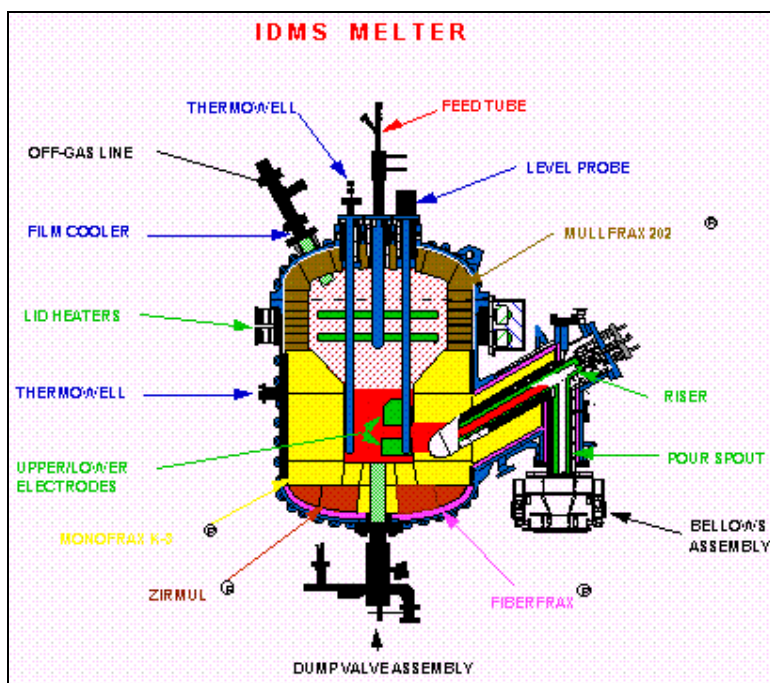

Fig. 2. IDMS Melter Section.
(Jantzen, 1999)

The DWPF melter (Figs. 3-4) is a water-jacketed, refractory-lined stainless steel vessel designed for waste vitrification at rates of 100 kg of glass per hour (Norman, 1992). Two pairs of submersed electrodes are used to pass current through the glass, utilizing the electrical resistance of the glass to generate the required heat. In addition, there are Inconel dome heaters (Fig. 4). The size of the melter and the quantity of materials that have to be dealt with in a decontamination & decommissioning (D&D) operation are quite large. Table 1 lists the components that make up the melter and their weight. The DWPF melter weights approximately 40% more than the WVDP's SFCM. In addition, the stainless steel frame structure, which is composed primarily of 3/8 in. (9.53 mm) stainless steel tubing, weighs an additional 77,000 kg. The volume of drainable glass is 2.22 m³ before any wall erosion.

Table 1. DWPF melter components.

Component	Weight (kg)
Vessel (stainless steel)	17,600
Frame(stainless steel)	12,900
Refractory	25,230
Piping	9,790
Components	1,200
Nozzle mounting materials	930
Wiring	150
Total	67,800

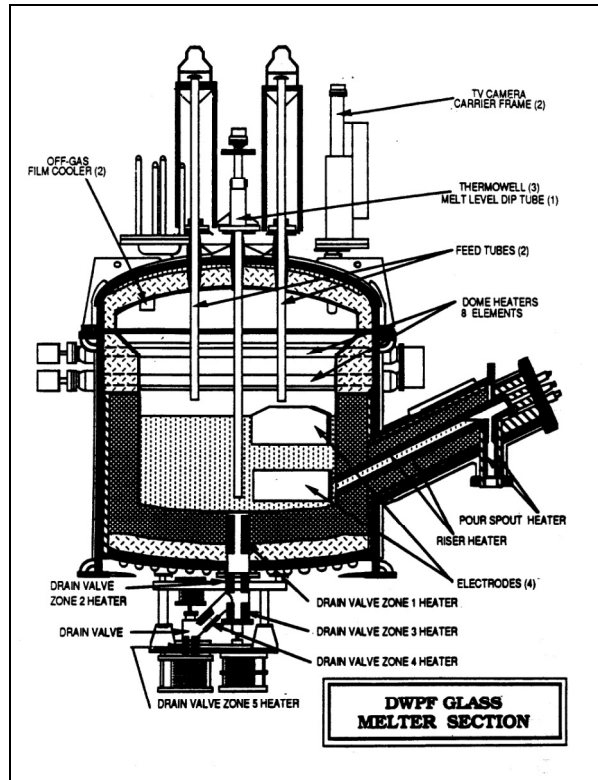

Fig 3. DWPF Melter Section.

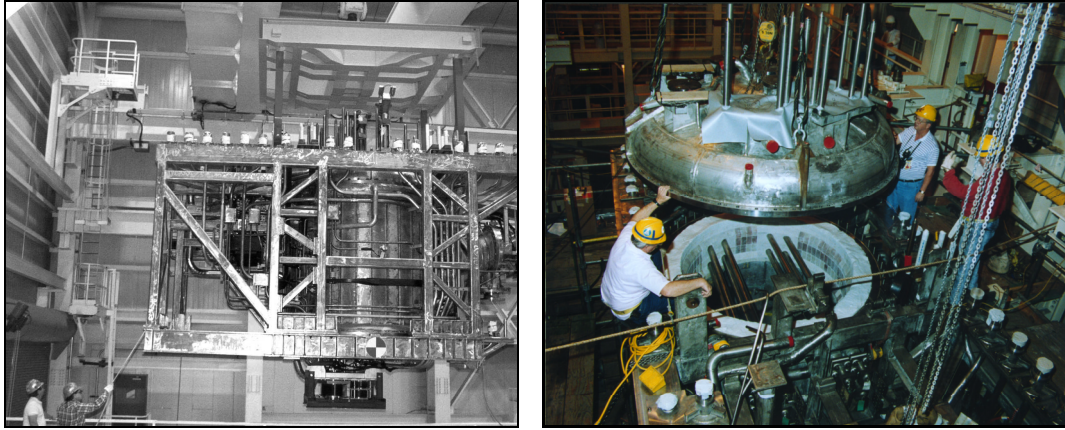

Fig. 4. DWPF Melter assembly and installation.

Pamela

The Pamela Plant (Fig. 5) in Dessel, Belgium, was used to vitrify high-level liquid reprocessing waste by using a ceramic melter. Initial vitrification operations were conducted from 1985 to 1991, with a second vitrification program to start in 1999, following D&D of the hardware components from the initial operations.

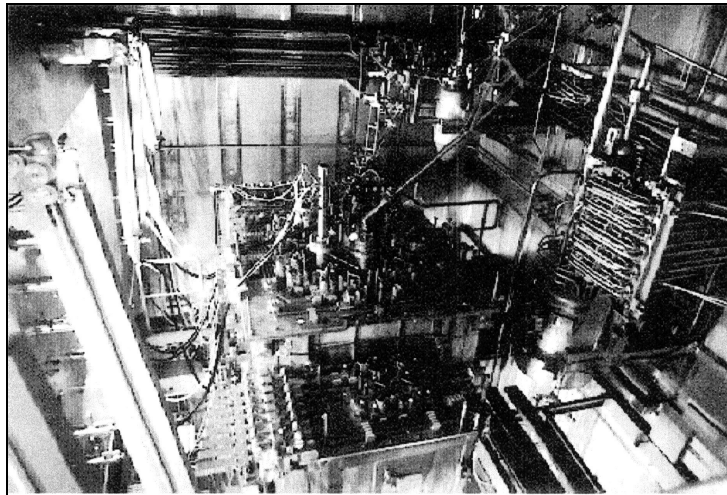

Fig. 5. Pamela vitrification plant.
(Demonic, 1994)

During the initial vitrification operations, some 900 m³ of waste concentrates were processed. In an initial feasibility demonstration, 47.2 m³ of waste concentrates from the reprocessing of power reactor fuels were incorporated into 77.8 metric tons of glass product, containing 7.67 metric tons of waste oxides (Demonic, 1994). The subsequent operations processed 777 m³ of waste

concentrates from the reprocessing of materials testing reactor fuels were incorporated into 411.7 metric tons of glass product, containing 88.94 metric tons of waste oxides (Demonic, 1994).

A cross section of the 2m x 2m x 2m cube-shaped ceramic melter is shown in Fig. 6. The total weight of the ceramic melter was 18 metric tons, with the refractory bricks (40 to 300 kg each) weighing 5 metric tons, the insulation material weighing 7 metric tons, and the stainless steel shell (3 to 20 mm thick) and additional equipment accounting for the rest (Demonic, 1994). Table 2 lists the basic components and characteristics of the melters.

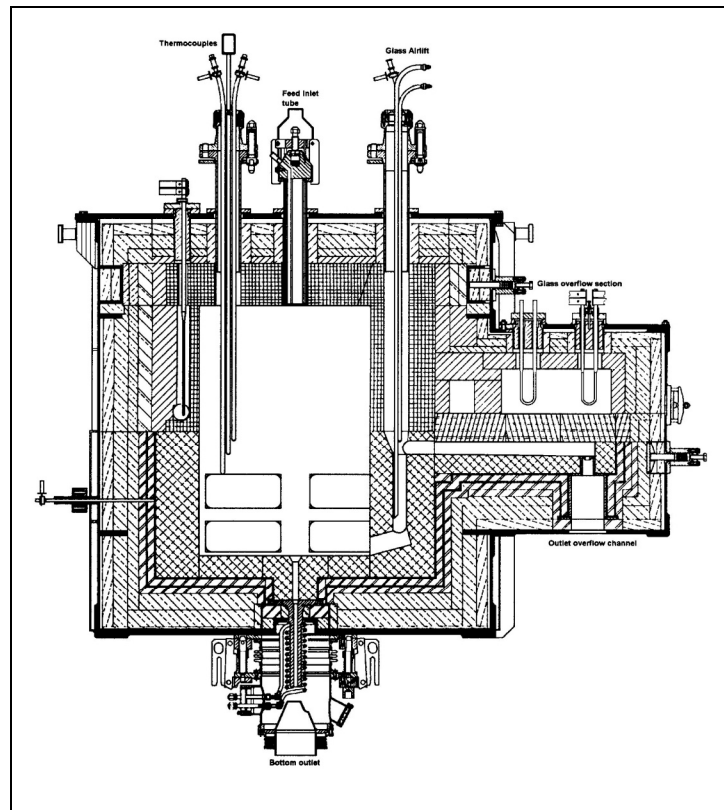

Fig. 6. Cross section of the Pamela melter.
(Demonic, 1994)

Table 2. Basic melter parameters.
(Demonic, 1994)

Melter Parameter	Dimensions, Value, or Quantity
External dimensions	2.0 x 2.0 x 2.0 m
Overflow unit dimensions	0.7 x 0.9 x 0.8 m
Refractory material (wt & volume)	5.2 metric tons 1.4 m ³
Insulation material (wt & volume)	7.3 metric tons 5.4 m ³
Built-in metallic components/devices (wt)	2.0 metric tons
Stainless steel containment (wt)	3.5 metric tons
Glass (wt & displacement)	0.8 metric tons 0.3 m ³
Total Weight	18.8 metric tons

D&D Experience

While the DWPF melter and the WVDP melter have not undergone D&D at this time, there is some relevant experience that could be beneficial. First, the remaining glass was removed from the IDMS melter prior to inspection after being shutdown in 1995. Second, the Pamela melter underwent D&D from 1992 through 1994. In addition, remote D&D operations have been performed on other types of systems. While the equipment being handled certainly varied significantly from the melters that are the subject of this report, there are common issues and concerns, including remote operations in radiation environments and the handling and size reduction of large components.

Pamela

From June 1992 through March 1994, four large components of the Pamela vitrification facility were dismantled. The equipment dismantled included one of the two ceramic melters that were used, the vitromet equipment, the wet dust scrubber, and the container lifting and weighing carriage. The details of the D&D operations are described in Demonic, 1994. A summary of the D&D operations is included here (Demonic, 1994).

The melter cell facility was used for dismantling due to the remote access already incorporated into the cell design. The cell includes 3 (1.0m x 0.8m) lead glass windows at ground level with master-slave manipulator pairs at each window. Three additional identical windows are located at a second level, 4 m higher, from which 2 are equipped with master-slave manipulator pairs. There is also one heavy duty, mast mounted, manipulator and a 2 metric ton overhead crane located in the melter cell. A schematic of the cell is shown in Fig 7.

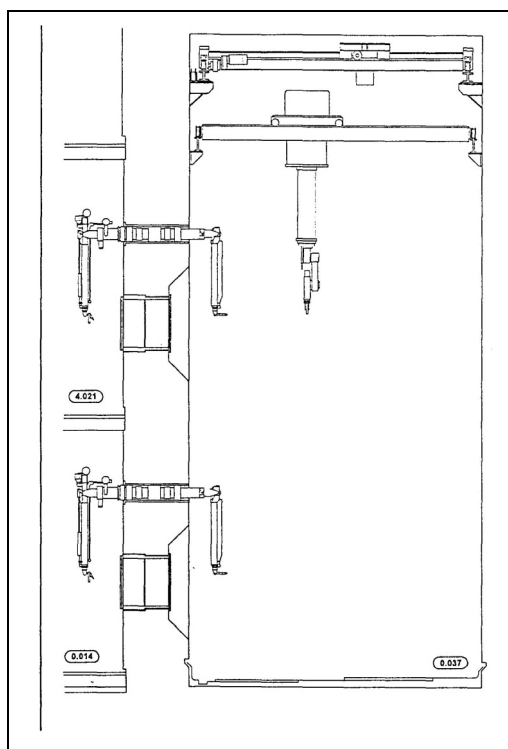

Fig. 7. Melter cell schematic.
(Demonic, 1994)

The melter and portions of the vitromet unit were size reduced in the melter cell facility prior to transport to the dismantling cell for packaging. Table 3 lists the dismantling sequence for the melter. The wet dust scrubber and the container lifting and weighing carriage were transferred as one piece prior to size reduction in the dismantling cell.

Table 3. Melter Dismantling Sequence.

Melter Dismantling Steps
1. Removal of all external and built-in devices including thermocouples, bottom outlet, electrical supply bars, piping, etc.
2. Removal of melter stainless steel lid, insulation and refractory material from glass bath ceiling, and overflow system. Transport of all dismantled parts to dismantling cell.
3. Cutting up stainless steel containment of overflow system.
4. Removal of insulation and refractory material from the melter walls.
5. Removal of insulation and refractory material from the melter floor.
6. Cutting up remaining containment and transport to dismantling cell for conditioning.

The dismantling operations were conducted using the through-the-wall manipulator systems and the mast-mounted manipulator. Traditional hand-held tools were modified and adapted for

remote operations. Tooling consisted of grinding discs, impact wrenches, hydraulic jacks, hammer drills, vacuum cleaners, and grippers. The existing ventilation system precluded the use of plasma torches for cutting of large metal structures. Diamond-tipped blades were initially used for cutting, but grinding discs were also tried and proved to be more efficient cutting stainless steel plates. Table 4 shows the approximate cutting rates for the blades and grinding discs.

Table 4. Cutting rates for stainless steel.

Tool	Thickness (mm)	Rate (mm/min)
Diamond blade	3 - 8	7 - 11
Grinding disc	3	700 - 850
Grinding disc	5	350 - 450
Grinding disc	10	180 - 230

The resulting waste was segregated based on activity level into low and medium level wastes. Medium level waste was cut up and placed in a 125 liter drums and then the drum was filled with cement. These drums were then placed in 200-liter drums, which were also filled with cement before being sealed with a double lid system.

The key lessons learned from the dismantlement of the melter and additional equipment is summarized in Table 5.

Table 5. Lessons learned from dismantling of Pamela melter.

Lessons Learned
— Dismantling requirements must be taken into account at design phase of plant.
— Access to and visual control in shielded cells must be easy.
— Manipulators must allow for operation of different tooling.
— Ventilation should not preclude the use of plasma torches.
— Larger drums should be used for packaging to reduce time-spent size reducing waste.
— Personnel retrained for dismantling must be experienced remote manipulator operators.

IDMS

As stated previously, the IDMS was shut down and inspected to gather data relevant to the DWPF melter, specifically to help in determining appropriate inspection schedules and to minimize the number of scheduled inspections. While the IDMS did not undergo D&D type activities, some of the experience gained from the inspection of the IDMS is relevant to future melter D&D activities, including the following activities (Jantzen, 1999):

2. Attempts to drain glass through the drain valve were unsuccessful due to an inoperative drain valve heater.
2. A high vacuum pour was performed to try to remove as much glass as possible. Approximately 30 cm (12 in) of glass remained in the melter after the pour.
3. The glass remaining in the bottom of the melter was core drilled. A total of 38 samples were removed for analysis.
4. The remaining glass was removed from the melter by bead blasting (like sand blasting, but with larger particles that do not damage the refractory) and chipping.
5. Remaining “blobs” of glass were then easily removed from the refractory.
6. All components in the vapor space region had yellow deposits. The melter lid, which also had the deposits prior to cleaning, was bead blasted to remove them.
7. The riser and pour spout were plugged after draining and were unplugged by drilling and bead blasting.
8. The feed tube was also plugged.

Other Relevant Large Scale D&D Operations

Chicago-Pile No. 5 (CP-5) D&D

The CP-5 research reactor, located at Argonne National laboratory, was a heavy-water-moderated and-cooled, highly enriched, uranium-fueled reactor designed to supply neutrons for research. An artist’s rendering, depicting a cutaway of the reactor block, is shown in Fig. 8. The reactor vessel itself was 1.8-m (6-ft) in diameter and 3.0-m (10-ft) long. The reactor had a power rating of 5 MW and was operated for 25 years until its final shutdown in 1979. Years of operation produced activation and contamination typical of many nuclear facilities within the DOE complex. The CP-5 remote tasks included cutting and dismantling the aluminum reactor tank, disassembling and removing the array of graphite blocks, removing boral and lead sheathing and lead bricks, and transferring these materials to a staging area for packaging. The Dual Arm Work Platform (DAWP) (Fig. 9) developed by Oak Ridge National Laboratory (ORNL) was used by the CP-5 operations staff to remove 27,000 kg (60,000 lb) of graphite blocks; 773 kg (1700 lb) of aluminum reactor vessel, piping and support bracing; 909 kg (2000 lb) of steel; 636 kg (1400 lb) of lead; and 282 kg (620 lb) of boral.

The DAWP, shown in Fig. 9, had many of the design components of the an earlier Dual Arm Work Module (DAWM), only reconfigured for CP-5. Shilling™ T3 manipulators were selected because they were more easily decontaminable than the T2’s. The DAWM style linear and rotary base platform actuators were also reused except that the Schilling™ linear actuators extended out from the base perpendicularly and the rotary joint provided a 90° change in arm base orientation from vertical to horizontal. The manipulation and base degree of freedom (DOFs) were mounted on a structure designed to be crane deployed and left either free swinging or sat down on the reactor block during task execution.

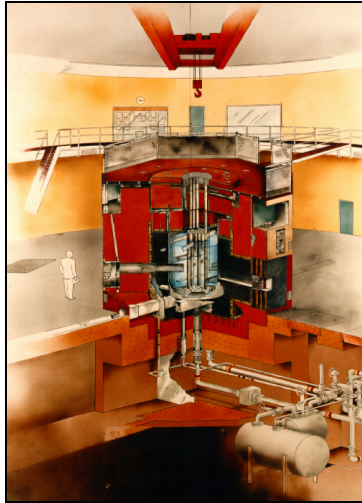

Fig. 8. Schematic of the CP-5 research reactor.

Two general comments are worth discussing (Noakes, 1998). First, operator skill level was an issue. The site required that existing union personnel be used to operate the system, despite the fact that none had any remote operating experience. While the task was completed successfully, past lessons learned on the need for experienced remote operators was clearly reinforced.

The second concerns reliability. The controls and mechanical hardware were generally reliable. The single exception was a recurring failure of the Schilling manipulator elbow joints on both manipulators. Although the cause was never firmly established, it could have been related either to the use of HoughtoSafe water-glycol hydraulic fluid or to some peculiar stresses placed on the Schillings because of the configuration of the manipulators on the DAWP base. ORNL has since gone to use of Shell Tellus mineral-oil-based hydraulic fluid in its development systems. Other failures included cameras and camera lenses, but these were caused almost exclusively to impact with the environment during placement of the DAWP or from the manipulators. Because this type of failure was expected, relatively inexpensive dome cameras were selected.



Fig. 9. DAWP working above the CP-5 research reactor.

Modified Brokk Demolition Machine with Remote Console

An integrated system, referred to as the Modified Brokk Demolition Machine with Remote Console, was deployed during D&D activities at the Idaho National Environmental & Engineering Laboratory (INEEL) South Tank Farm (STF) in January 2000. Specifically, the system was used by an operator to remotely remove, size-reduce, and stage overhead piping and facility equipment located in the basement of the STF. Prior to using the Modified Brokk Demolition Machine with Remote Console, this work was being done with the operator in the area in direct line-of-sight of the operation. The system consisted of the ORNL compact remote console (CRC) integrated with the commercially available Brokk 250, to provide a functional, relatively low cost remote D&D capability.

The Brokk 250 consists of a revolving table, which is capable of continuous rotation and mounted on a tractor-like base. Solid rubber wheels mobilize the equipment, and hydraulic outriggers extend beyond the tires to add stability during operation. The unit requires a 480-V ac, 50-A circuit for its power source. The Brokk can be operated from 400-ft away using either a tethered portable controller or a wireless radio frequency (rf) portable controller. In the baseline mode, the Brokk is controlled by an operator standing in close proximity to the machine with line-of-sight vision of the work site. Fig. 10 shows the Brokk BM 250 being used for D&D activities while using the wireless rf controller.

Following are some of the physical characteristics of the Brokk 250:

Weight:	6,750 lb. without attachments
Minimum Height:	3.61 m
Minimum Width:	1.50 m
Minimum Length:	1.19 m.
Operating width:	2.46 m
Maximum Attachment Weight:	299 kg
Hydraulic breaker energy per blow:	1356 Nm

Various tool head attachments are available for this system including a hydraulic hammer, an excavating bucket, a concrete crusher, and a La Bounty Shear, which is shown in Fig. 10. The La Bounty Shear was the primary tool head used for this demonstration and is capable of cutting rebar, pipe, and other metal and weighs approximately 600 lb. A field demonstration of a Brokk BM 150 was conducted in 1997-1998 at CP-5 Research Reactor Large-Scale Demonstration Project. An Innovative Technology Summary Report (ITSR), "Remote-Controlled Concrete Demolition System", was written in April 1998 detailing the use of the Brokk 150 versus jackhammers for concrete removal.

In order to perform D&D activities from a truly remote non-line-of-sight location, the Brokk 250 was retrofitted with two image-stabilized cameras mounted in a pan-and-tilt aluminum enclosure. The image-stabilized DRaySEE camera system is commercially available from RVision, Inc., and produces 350 lines NTSC video, pans 360°, tilts 110°, and provides 24 times image magnification (12X optical). The 12-V dc system requires separate power for the pan-and-tilt functions and a serial interface to control camera zoom features. These two cameras were

mounted on two actuated arms, which are located on the Brokk 250's cover. The actuated arm system allows the cameras to be positioned in the optimal viewing position during work activities and to be retracted while the Brokk is being moved throughout the remote area. By mounting the camera and actuator system on the cover, the Brokk 250 can easily be changed from remote-camera ready to original equipment by simply interchanging covers.

The purpose of the CRC is to condense a typical multi-monitor, multi-rack large operator control console into a single, and easy-to-relocate ergonomic station. The CRC measures 30" x 61" x 76" and consists of a 4-panel video array, which is mounted on a mast in front of an ergonomic chair. These are subsequently mounted on a base, which serves as an enclosure for associated power, video switchers, and control and fiber-optic electronics. Also mounted on a swivel arm on the CRC is a control computer with a touch-screen, which serves as an intuitive graphical user interface to the Modified Brokk Demolition Machine. Figure 11 shows the CRC with an integrated portable Brokk 250 controller and an inside view of the base enclosure. For an in-depth, detailed discussion of the CRC, see ITSR OST/TMS ID 2180, "Compact Remote Operator Console", August 2000.

The benefits from this Modified Brokk Demolition Machine with Remote Console include:

- operable by remote control, allowing the operator to be positioned at a safe distance from high radiation areas, falling debris, cold and hot temperatures, and other environmental concerns;
- working time less than half that of most manual tools, significantly reducing cost, schedule, and worker radiation exposure;
- powered by a 480-V ac, 3-phase motor, eliminating problems of exhaust fumes in containment areas;
- useful for a wide range of tasks in various work conditions from breaking, removing, and loading concrete debris to removing radioactive waste from high radiation areas;
- And durable—operated on double 10-hour shifts for weeks without failure (expected useful life is about 10 years).



Fig. 10. Modified Brokk performing facility D&D task.

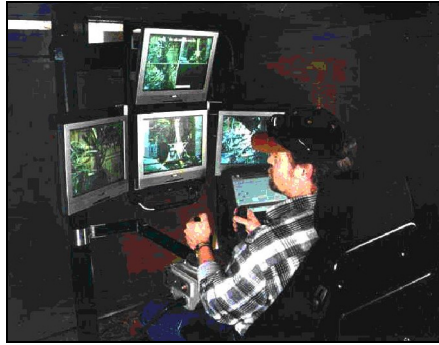

Fig. 11. Compact Console controlling the modified Brokk.

Commercial Capabilities

There are commercial suppliers of relevant hardware and services. This can take the form of components that can be made into remote systems to perform required tasks to complete systems and services based on tethered operation. Keibler-Thompson of New Kensington, Pennsylvania provides both services and hardware systems targeted at foundries, metal producers including steel mills, cement plants, glass melters and others industries. Keibler-Thompson features special remote controlled equipment and skilled operators. Other vendors, such as Brokk AB and RedZone, provide relevant hardware components and systems.

Keibler-Thompson™

Keibler-Thompson (www.keibler-thompson.com) manufactures a wide range of remotely controlled heavy-duty, industrial equipment for refractory tear-out, descaling, and other applications. They also provide a variety of attachments for use with most of their machine models. These include hydraulic and pneumatic hammers, buckets, shears, grapples, refractory profiling grinders, tap hole reamers, and other custom designed tooling.

Keibler-Thompson equipment features telescoping booms equipped with pneumatic or hydraulic hammers that allow full reach for deslagging, descaling or refractory tear-out. Some models are designed with their own stabilizing outriggers to allow them to clamp on top of or inside furnaces or tanks.

Shown below in Fig. 12 are representative Keibler-Thompson systems. Note that the systems are remotely controlled using a hand-held pendant. Systems that are floor mounted, vehicle mounted, and mounted on top of the targeted system are shown in the figure.

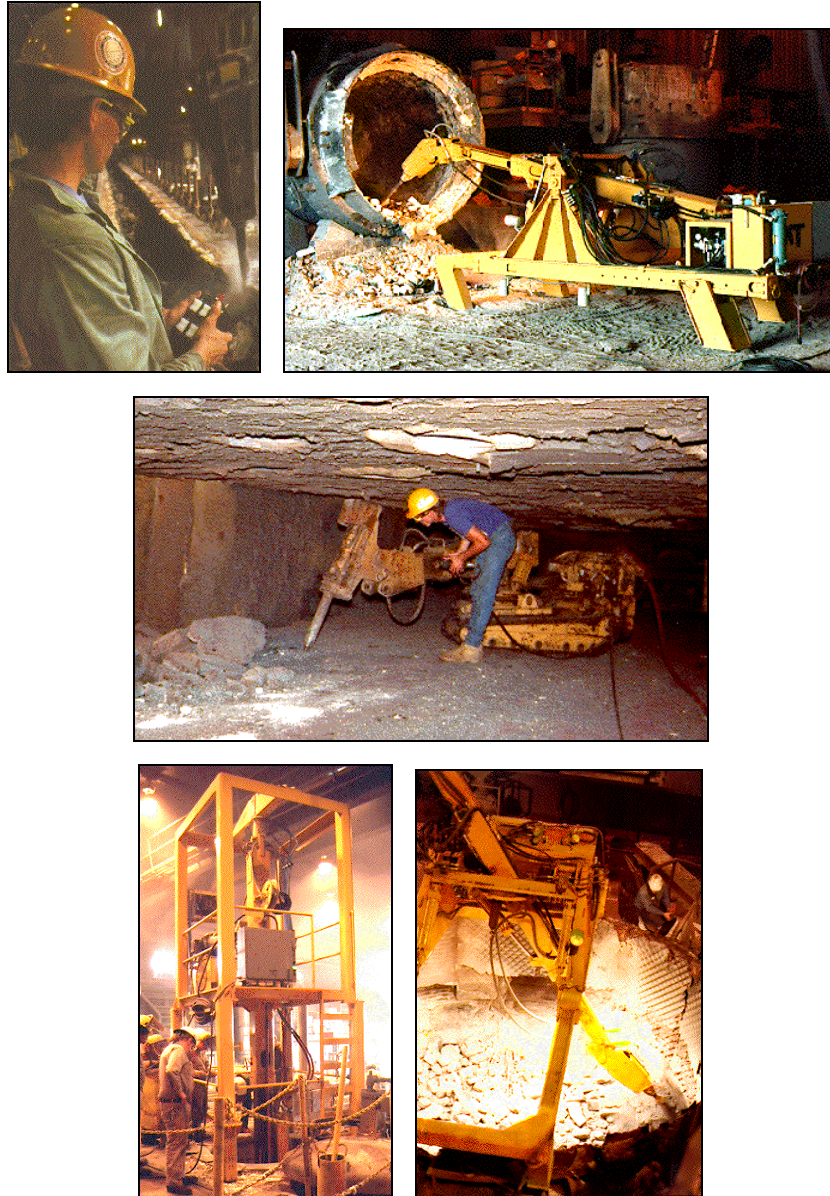

Fig. 12. Keibler-Thompson remote systems.

Brokk

Brokk is a remote-controlled, electrically driven demolition machine manufactured by Brokk AB, a fully owned subsidiary of Sorb Industri AB of Skellefteå, Sweden. Brokks come in a variety of models and sizes and can be outfitted with different tooling, including shears and jackhammers, in similar fashion to the remotely controlled mobile equipment offered by Keibler-Thompson . Figure 13 shows a Brokk 250 outfitted with a shear performing D&D activities.

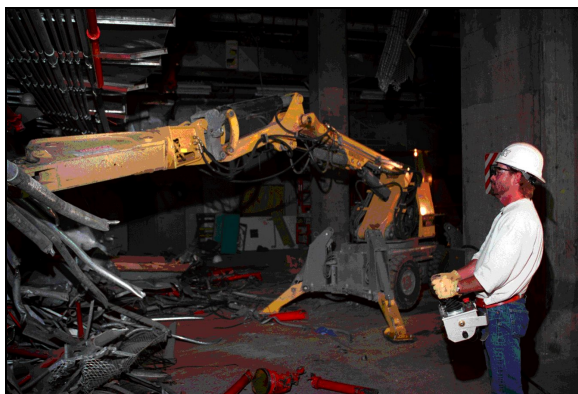

Fig. 13. Brokk remote controlled system performing D&D tasks.

Tooling

One of the primary tasks for size reduction is cutting. Cutting large structural elements remotely significantly increases the difficulty. Additionally, remote routine maintenance of the cutting tool, such as blade replacement, increases the complexity.

ORNL conducted a study of tooling requirements for remote D&D activities in 1995 (Evans, Noakes, Kwok, 1995). The report was never formally published. An emphasis of that study was remote cutting, which is pertinent to the purposes of this report. The findings and results of that study will be drawn upon in addressing issues relating to cutting here.

Remote Cutting

Cutting tools and processes generally can be categorized based on the method of cutting, namely sawing, shearing, melting/gas jet kerf removal, or ultra-high-pressure fluid impingement. There are multiple approaches to each method, and applications where each is more advantageous than the other methods.

Sawing is the simplest and most obvious method of cutting. Use of relatively inexpensive, familiar hand-held tooling with favorable operating envelopes makes saws desirable for many applications. The productivity of cutting with saws, however, is relatively low. In general, experience has shown that the use of rotary saws fare better than reciprocating saws. While different saws may be better suited to specific tasks, the ORNL study recommended the abrasive saw for general use based on the following (Evans, Noakes, Kwok, 1995):

1. Remote blade replacement is straightforward.
2. The probability of blade breakage is significantly less than with a reciprocating hacksaw and about the same as with a band saw.
3. The operating envelope is less than that of the band saw and about the same as that of a reciprocating hacksaw.
4. The effective depth of cut is similar for all three systems.
5. The productivity of the abrasive saw is superior.

This is consistent with the experience at the Pamela Plant, where they were able to increase the cutting rate of stainless steel plate by more than an order of magnitude when they changed from using diamond blades to abrasive grinding discs (Demonie, 1994).

Shearing is superior to the other methods for applications such as cutting tubing, small pipes, electrical cable and conduit. Shears have been modified for remote use with manipulator systems with good productivity. Sheet metal nibblers have also been modified for remote use and have proven to be more productive than sheet metal shears because of a greater capacity (thicker metal) and the geometric form of the kerf (Evans, Noakes, Kwok, 1995). The nibbler, is based on a punch-and-die principle and produces individual kerf pieces, while the shears produce a continuous strip which tends to foul in cabling and adjacent equipment (Evans, Noakes, Kwok, 1995).

A melt/gas jet kerf removal process is appealing because of the ease with which thicker materials can be cut and the resulting increase in productivity. Several different processes are available, including oxyacetylene torch, plasma arc cutting, and arc cutting. Noxious fumes and potential fire hazards (in the presence of a fuel) are disadvantages with these processes. Recall that one of the lessons learned from the dismantlement of the Pamela melter was that ventilation systems should not preclude the use of plasma torches. Remotely deployed collection systems, to collect or filter noxious fumes, is an issue that requires further investigation.

The oxyacetylene torch works by heating the steel to a high temperature, which causes it to readily combine with the oxygen forming oxides and the metal to be disintegrated and burn rapidly. The rate of cutting is dependent on the material thickness, tip size, and oxygen pressure. Carbon content of steel also impacts cutting, as higher carbon steels require greater preheating. Other gases, such as gasoline or hydrogen, have been used in a similar fashion. While this method of cutting works well with steel, which oxidizes readily, it does not readily cut materials such as cast iron, stainless steel, and other nonferrous materials that do not oxidize as easily. Stainless steel produces oxides that slow the melting-away process. Use of a flux-injection method to inject flux into the oxygen stream can remove the inhibiting oxides, and make the oxyacetylene torch practical for stainless steel as well.

Plasma arc cutting can be accomplished by using higher currents and gas flow rates, which are typically used for welding. Proximity of the nozzle to the cutting surface is an issue as the high velocities of the plasma jet, increased by the restricting nozzle, are used to blow the metal away as it is melted, thus making the cut. The plasma arc process is typically faster than oxygen/fuel torches. Recasting of molten metal on the edges can be a problem, but would obviously not be an issue in D&D applications.

Glass Removal

It will be desirable to remove residual glass, as it is HLW, from inside the melter, as well as that splattered outside on support structure surfaces. Mechanical chippers (such as small jackhammers or pneumatic chisels) have been previously used to remove glass from melters.

Removal of large quantities of glass using mechanical chipping can be a slow and tedious task as the glass can be difficult to chip off. Operating remotely adds to the difficulty.

Another possible approach to removing large sections of glass is to “score” the glass, effectively making a number of smaller sections as opposed to a single large section of glass. At that point, using mechanical chippers may be more productive. Whether such an approach is cost effective or operationally effective would probably require some testing to determine.

Savannah River used bead blasting to remove glass from the IDMS. Adapting for remote operation and handling the residual material will require more investigation.

CP-5 Experience

A more detailed description of tooling issues can be found in (Noakes, 1998). A summary of the key issues is discussed here. Tooling was consumed regularly and was both worn out and broken in operation, as was anticipated. The tool that was used most during reactor vessel sectioning was a heavy-duty circular saw outfitted with a carbide-tipped blade and a vegetable-oil-based cooling system. Blades had to be changed periodically, and the saws wore out frequently. Generally, the DAWP was sent into the reactor block with several saws on its deck and did not leave until all the saws were dull or broken. Because the saws were relatively inexpensive to procure locally and were simply outfitted with handles for remote operation, cost per saw was not severe. The general philosophy for remote tooling support for DAWP at CP-5 was to buy commercially available tools and to outfit them with handles compatible with the Schilling manipulator. Custom tooling or the use of the Schilling tool interface port was not pursued. Although control, positioning, and utilities for tooling would have been easier with the tool interface on the manipulators, the large number and wide array of custom tools required would have been cost prohibitive. Instead, commercially available drills, impact wrenches, cut off saws, portable band saws, air chisels, and hand tools were modified for remote operation. The only tool that showed promise but could not be adequately deployed was a 3.7 kW (5-hp) router that was fitted with a milling bit to provide a hand-held milling machine. The target application was sectioning of the reactor vessel. The operators and the Schilling arms had difficulty with the large and unwieldy tool package, and it was difficult to dial in the cutting speed on the milling bit such that it would cut the aluminum vessel but would not melt the aluminum and foul the bit. Precise positioning was also difficult. In general, tooling and efficiency of operation were an issue. Highly automated tooling would have been too costly and required too much time to adapt and test for the changing CP-5 scenarios; however, using simple tooling without operator assists can be difficult for inexperienced operators. An in-between tooling philosophy that emphasizes smarter tooling with operator assists but does not go so far as to require the costs of full automation would have worked better with the inexperienced operators.

Dispensation Options

The focus of this report is on glass removal methods and disposal strategies matching technology and optimal end states. For a failed glass melter, potential end states include (1) dismantling and repackaging for long-term storage (complete D&D); (2) long-term storage without undergoing complete D&D; and (3) refurbishment for possible reuse.

Regardless of the desired end-state, there is a real possibility that the melter will still contain a significant amount of glass like. While still operational, draining of the IDMS melter through the bottom valve failed on multiple attempts due to an inoperative drain valve heater. Approximately 12 inches of glass remained in the bottom of the 1/10 scale IDMS melter after the final pour. At the Pamela plant, both melters failed when the bottom outlet became blocked. However, at the WVDP, two attempts to drain the melter resulted in only 5% of the glass left in the melter on each occasion. Based on experience to date, there is a reasonable chance that, depending upon the melter design and other parameters, a significant amount of glass will remain in the melter when it is shut down, complicating the processing of the melter to its desired end-state.

To reduce the dose level and the subsequent storage and/or disposal requirements, would require removal of all the glass in the melter, as well as glass that might have been splattered on the support structure during operation of the melter. Mechanical chipping, with a tool such as a jackhammer or a pneumatic chisel, has been utilized for removal of glass, but with some difficulty. Savannah River, when removing a significant amount of glass from the IDMS melter, employed a number of methods. First, they core drilled the remaining glass (primarily to get samples for analysis), then they bead blasted the remaining glass. The bead blasting, which is like sand blasting but with larger particles, was able to chip away at the glass without damaging the refractory. Mechanical chipping was used to remove the remaining glass. Adapting the bead blasting and chipping for remote operations would require some issues to be addressed, namely dealing with the bead material, a pneumatic supply for the chipping tool, positioning of the tools and viewing the work surface.

There is an issue of where the processing of melters to their end-state takes place. Plans for disposal of melters from the DWPF assumed that a separate facility would be made available for D&D activities sometime after the turn of the century. It was assumed that, when designed, funded, and built, this large shielded facility would have the capability to (1) handle the gross weight of a full melter; (2) reduce the size of the assembly; (3) survey the remains and segregate them into remote-handled and contact-handled waste; (4) containerize them; and (5) ship them out to various destinations (Norman, 1992). As previously noted, the melter cell facility itself was used for D&D of the Pamela melter and other equipment. The D&D activities were completed in 2-1/2 years (only 1 of the 2 melters underwent D&D). Obviously, if the melter cell facility is used for D&D activities, subsequent vitrification activities must be done sequentially with the D&D, as opposed to in parallel.

Refurbishment

Recent results from the on-going vitrification efforts at the SRS and WVDP have shown that melter life have exceeded initial expectations. The ability to refurbish melters offers the potential of additional cost savings. Specifically, refurbishment of melters has the advantages of reusing equipment with a significant capital investment, minimizing waste, and allowing for the reduction in procurement of backup systems and the associated long lead times.

There may be multiple difficulties associated with refurbishment. Not the least of which is that the condition of the melter, and the practicality of refurbishing a particular melter may not be readily determinable until after significant effort has been expended. Based on the examination of other melters, the items listed in Table 6 may have to be addressed.

Table 6. Refurbishment issues.

Potential Refurbishment Issues
— Significant quantities of glass remaining in the melter.
— Melter openings, including the bottom drain, pour spout, and feed tubes may be plugged.
— Thinning and spalling of melt pool refractory, especially along the bottom.
— Corrosion of the bottom drain valve.
— Electrodes wear or damage.
— Cracks and thinning of melt and vapor thermowells.

Long-Term Storage

Long-term storage of the melter assembly may be possible, but may not be an acceptable solution. Plans have already been made for temporary storage of failed melters. For instance, at the DWVF the following steps have been laid out for handling of a failed melter (Norman, 1992):

- Disconnect the melter from the plant.
 - Move the assembly to a remote equipment decontamination cell (REDC).
 - Move into a rail-mounted multi-purpose container.
9. Transfer to a failed equipment storage vault for temporary storage.

If long-term storage is deemed acceptable, then issues concerning removal of HLW glass and storage location will have to be addressed. Removal of the HLW glass that remains in the melter before final packaging and the impacts on long-term storage requirements will need to be addressed. At what point are the storage requirements lessened and is the amount of effort and cost required to reach that point economically and/or otherwise justifiable?

Complete D&D

Of the melters included in this study, only the Pamela melters have undergone complete D&D, including remote sizing, packaging, and disposing of waste. Others, such as the IDMS and the SFCM have been operated, had the glass removed, and have been thoroughly inspected following shutdown. The advantages of completely resizing and repackaging the melter assembly allows for segregation of the waste and a minimization of the stored waste volume.

The primary tasks associated with complete D&D are decontamination and size reduction. Issues related to both will be briefly discussed. Also of concern is the determination of where the work will be done. Selection of a site for D&D operations and the type of equipment that will support remote operations are extremely important.

The most obvious task associated with decontamination is the removal of highly contaminated glass. As noted previously, removing the glass from the melter, especially in large quantities, and from the support structure (incidental splatter), is not a trivial task. Methods for removing glass, and the associated tooling, including mechanical chippers, grinders, and saws were discussed above in the tooling section.

For the task of remote size reduction, tooling issues are a primary concern. The ability to use the most effective cutting tools, including oxyacetylene torches and plasma arc cutters could have a significant impact on efficiency, especially when the amount of material to be handled is considered.

The approach to be taken certainly will have an impact on the tooling required as well. For instance, is the refractory removed before size reduction of the shell or are these tasks done in reverse order? Will the refractory have to be cut out using diamond-tipped saw blades, or, if the shell is removed first, can a hydraulic jack be used to break-up the refractory? The experience at Pamela was that they removed the shell first and then planned on using diamond tipped saw blades to cut out the refractory. They discovered that it was actually much easier to use a simple hydraulic jack to break apart the refractory than to cut the refractory.

The size of the container that can be used for size reduction will also have a significant bearing on operational efficiency. It will determine how much time must be spent cutting pieces up to fit in the containment vessels. Obviously from an operations standpoint, the larger the better.

Other lessons learned from the D&D experience at Pamela are certainly valid and valuable. Of particular significance is the need for the ability to use a variety of different tools and the desire to be able to use more efficient cutting tools, such as plasma torches. It was noted that larger packing drums were needed to reduce time and effort spent on size reduction. Also worth noting is the recognition that experienced remote manipulator operators are required. Efficient remote operations are highly dependent upon experience. Their findings are consistent with the experience that we have had at ORNL.

Conclusions

There are many issues related to glass removal and how to efficiently process a contaminated melter to the desired end-state. This report has addressed relevant experience and issues and concerns that need to be addressed. Compiling and briefly describing these issues is only an initial step in addressing them.

The first issue is, what is the desired end-state and what are the drivers for reaching that end-state? A related issue is, what facilities are available in which to process the melter to the desired end-state? At DWPF, for example, plans were made early in the program for size reduction and disposal at a “to be determined” facility. The REDC does not have enough room to access the melter so that it can be processed to the desired end-state condition. A similar situation existed at Pamela, where D&D activities were actually shifted to the melter cell because of an opening in their scheduled activities.

Regardless of the desired end-state, it has been assumed that removal of the glass from the melter and the support structure will be cost effective. Issues on tooling are unresolved. First, from a facility standpoint, can cutting tools such as oxyacetylene torches and plasma arc cutters be used? Are modifications to filtering systems feasible, practical, and cost effective? Second, what tools will allow for the most efficient removal of the glass and help to minimize the amount of waste that must be treated as HLW? Use of the early scale melters (that were used in simulated waste tests), in conjunction with the on-going remote D&D work supported by the Robotics Cross Cutting Program and Deactivation and Decommissioning Focus Area, could provide a means for studying tooling issues and determining the most efficient methods of remote glass removal. These same melters could also be used to determine the best methods for dismantlement and size reduction of melters.

References

Brooks, R., 1995, "Slurry Fed Ceramic Melter Disassembly Report", CMH032493, West Valley Nuclear Services Co., Inc., West Valley, New York.

Carl, D. E., J. Paul, J. M. Foran, and R. Brooks, 1990, "West Valley Demonstration Project Vitrification Process Equipment Functional and Checkout Testing of Systems (FACTS), DOE/NE/44139-64, West Valley Nuclear Services Co., Inc., West Valley, New York.

Chapman, C. C., and W. P. Drosjack, 1988, "Vitrification Process Equipment Design for the West Valley Demonstration Project", DOE/NE/44139-42, West Valley Nuclear Services Co., Inc., West Valley, New York.

Demonie, M., P. Luycx, M. Snoeckx and L. Baeten, 1994, "Experience Gained with the Dismantling of Large Components of the Pamela Vitrification Plant", Belgoprocess, Dessel Belgium.

Evans, J., M. W. Noakes, and K. Kwok, 1995, "An Assessment of Tooling Requirements for a Dual-Arm Manipulator System Performing Decontamination and Dismantlement of Nuclear Facilities", ORNL Internal Report, Oak Ridge, Tennessee.

Jantzen C. M. and D. Lambert, 1999, "Inspection and Analysis of the Integrated DWPF Melter System (IDMS) After Seven Years of Continuous Operation", WSRC-MS-99-00336, Westinghouse Savannah River Company, Aiken, South Carolina.

Noakes, M. W., 1998, "Remote Dismantlement Tasks for the CP5 Reactor: Implementation, Operation, and Lessons Learned", *Spectrum 98 Inter. Conf. on Decommissioning and Decontamination and on Nuclear Hazardous Waste Management*, Denver, Colorado.

Norman, E. C., P. J. Brackenbury, and J. King, 1992, "Disposal of Failed Melters from Defense Waste Vitrification Facilities", WHC-SA—1318, Westinghouse Hanford Company, Richland Washington.

Robotics Cross Cutting Program, Deactivation and Decommissioning Focus Area, August 2000, "Modified Brokk Demolition Machine with Remote Console", ITSR OST/TMS ID 2938, U.S. Department of Energy, Office of Environmental Management, Office of Science and Technology.

Vance, R. F., B. A. Brill, D. E. Carl, D. S. Hardip, R. A. Meigs, and M. G. Studd, 1997, "Design of Equipment Used for High-Level Waste Vitrification at the West Valley Demonstration Project", DOE/NE/44139-73, West Valley Nuclear Services Co., Inc., West Valley, New York.

Internal Distribution

1. J. N. Herndon
2. D. C. Haley
3. C. P. McGinnis
4. B. S. Richardson
5. S. M. Robinson

External Distribution

6. B. L. Burks, The Providence Group, 10330 Technology Drive, Knoxville, Tennessee 37932
7. L. D. Bustard, Sandia National Laboratories, P. O. Box 5800, MS 0728, Albuquerque, New Mexico 87185-5800
8. E. J. Cruz, U. S. Department of Energy, P. O. Box 550, MS H6-60, Richland, Washington 99352
9. F. Damerow, West Valley Nuclear Services, P.O. Box 91, WestValley, New York 14171
10. J. L. Drake, Jr., U.S. Department of Energy, 10282 Rock Springs Rd., West Valley, New York 14171
11. Tanks Focus Area Headquarters Program Lead, c/o K. Gerdes, U.S. Department of Energy Office of Science and Technology, 19901 Germantown Rd., 1154 Cloverleaf Bldg., Germantown, Maryland 20874-1290
12. P. W. Gibbons, Numatec Hanford Corporation, P. O. Box 999, MSK9-91, Richland, Washington 99352
13. D. Green, U.S. Department of Energy, Oak Ridge Operations Office, P.O. Box 2001, Oak Ridge, Tennessee 37830-8620
14. T. S. Gutmann, U. S. Department of Energy, Savannah River Operations Office, P. O. Box A, Aiken, South Carolina 29802
15. E. W. Holtzscheiter, Westinghouse Savannah River Company, Savannah River Technology Center, Bldg. 773-A, RM A-229, MS 28, Aiken, South Carolina 29802
16. J. O. Honeyman, CH2M Hill (CHG), P. O. Box 1500, MS H6-62, Richland, Washington 99352

17. J. P. Morin, Westinghouse Savannah River Company, Savannah River Technology Center, Bldg. 703-H, Aiken, South Carolina 29808
18. Tanks Focus Area Program Manager, c/o T. P. Pietrok, U.S. Department of Energy, Richland Operations Office, P. O. Box 550, MS K8-50, Richland, Washington 99352
19. M. T. Terry, Pacific Northwest National Laboratory, P. O. Box 999, MS K9-91, Richland, Washington 99352
20. T. R. Thomas, Lockheed Martin Idaho Technologies Company, P. O. Box 1625, MSIN 3458, Idaho Falls, Idaho 83415-3423
- 21-28 Tanks Focus Area Technical Team, c/o B. J. Williams, Pacific Northwest National Laboratory, P. O. Box 999, MS K9-69, Richland, Washington 99352