

The Production Process, Thermophysical Properties, and Quality Assurance Process for the Provision of Enhanced Accident Tolerant Fuels: ORNL Rodlets for the ATR ATF-1 Experiment

July 26, 2013

**G. L. Bell
M. C. Vance
K. A. Terrani
L. L. Snead
C. Shih**



DOCUMENT AVAILABILITY

Reports produced after January 1, 1996, are generally available free via the U.S. Department of Energy (DOE) Information Bridge.

Web site <http://www.osti.gov/bridge>

Reports produced before January 1, 1996, may be purchased by members of the public from the following source.

National Technical Information Service
5285 Port Royal Road
Springfield, VA 22161
Telephone 703-605-6000 (1-800-553-6847)
TDD 703-487-4639
Fax 703-605-6900
E-mail info@ntis.gov
Web site <http://www.ntis.gov/support/ordernowabout.htm>

Reports are available to DOE employees, DOE contractors, Energy Technology Data Exchange (ETDE) representatives, and International Nuclear Information System (INIS) representatives from the following source.

Office of Scientific and Technical Information
P.O. Box 62
Oak Ridge, TN 37831
Telephone 865-576-8401
Fax 865-576-5728
E-mail reports@osti.gov
Web site <http://www.osti.gov/contact.html>

This report was prepared as an account of work sponsored by an agency of the United States Government. Neither the United States Government nor any agency thereof, nor any of their employees, makes any warranty, express or implied, or assumes any legal liability or responsibility for the accuracy, completeness, or usefulness of any information, apparatus, product, or process disclosed, or represents that its use would not infringe privately owned rights. Reference herein to any specific commercial product, process, or service by trade name, trademark, manufacturer, or otherwise, does not necessarily constitute or imply its endorsement, recommendation, or favoring by the United States Government or any agency thereof. The views and opinions of authors expressed herein do not necessarily state or reflect those of the United States Government or any agency thereof.

Fusion & Materials for Nuclear Systems Division

The Production Process, Thermophysical Properties, and Quality Assurance Process for the Provision of Enhanced Accident Tolerant Fuels: ORNL Rodlets for the ATR ATF-1 Experiment

G. L. Bell, M. C. Vance, K. A. Terrani, L. L. Snead, and C. Shih

Date Published: July 2013

Prepared for the
United States Department of Energy –
Office of Nuclear Energy
under the
Light Water Reactor Sustainability Program’s
Advanced LWR Nuclear Fuels Pathway

Prepared by
OAK RIDGE NATIONAL LABORATORY
Oak Ridge, Tennessee 37831
managed by
UT-BATTELLE, LLC
for the
U.S. DEPARTMENT OF ENERGY
under contract DE-AC05-00OR22725

Intentionally Left Blank

CONTENTS

	Page
LIST OF FIGURES	v
LIST OF TABLES	vii
1. INTRODUCTION	1
1.1 DOCUMENT PURPOSE	1
1.2 BRIEF DESCRIPTION OF FCM FUEL FORM AND PATH TO LEAD TEST ROD IRRADIATION IN A COMMERCIAL LWR	1
1.3 ALTERNATIVE FUEL CLAD DEVELOPMENT	3
1.4 EXPERIMENT MATRIX	3
2. ADVANCED CLAD IRRADIATION CAPSULES	5
3. FCM FUEL IRRADIATION CAPSULES	6
3.1 KERNEL FABRICATION	6
3.2 LWR TRISO COATING	6
3.3 PELLET FABRICATION	7
3.3.1 Overcoating	7
3.3.2 Pellet Compaction	7
3.3.3 Heat Pressing	7
3.3.4 Grinding to Size	8
4. THERMOPHYSICAL PROPERTIES OF FCM FUEL	9
5. QA PROCESS	10
5.1 DESCRIPTION OF QA APPROACH AND REQUIREMENTS	10
5.1.1 Activities Grading and Work Planning, Control, and Documentation Considerations	10
5.1.2 Identification and Control of Test Articles	12
5.1.3 Data Package Compilation and Product Shipment	13
5.1.4 Fabrication of Test Rodlets	13
5.2 ATR EXPERIMENT ACCEPTANCE REQUIREMENTS	14
5.3 IRRADIATION TESTING DOCUMENT STRUCTURE	15
5.3.1 Program Documents	15
5.3.2 Irradiation Test Plan	17
5.3.3 Irradiation Test Specification	18
5.3.4 Capsule Design and Fabrication	19
5.3.5 Fuel Product Specification	23
5.4 QUALITY CONTROL	24
5.4.1 Product Inspection Plan	24
5.4.2 Data Acquisition Methods	25
5.4.3 Inspection Report Form	26
5.4.4 Final Data Package	28
6. REFERENCES	29
APPENDIX A	A-1

Intentionally Left Blank

LIST OF FIGURES

	Page
Fig. 1. Progression of the FCM fuel form from a TRISO particle in a SiC matrix to a LWR fuel bundle.	2
Fig. 2. Matrix of currently proposed irradiation tests showing the fuel form, clad type, and number and timing of irradiation cycles.	4
Fig. 3. Existing basket assembly to be adapted for use in the ATF-1 Test Series.	21
Fig. 4. Cross-section of existing basket assembly to be adapted for use in the ATF-1 Test Series.	22
Fig. 5. Existing test capsule/rodlet configuration to be adapted for use in the ATF-1 Test Series (dimensions shown in inches).	22
Fig. 6. Example flow diagram for an AGR Program product inspection plan.	25
Fig. 7. Representative Data Report Form used to document acceptance testing of the PyC density.	26
Fig. 8. Representative Inspection Report Form used to document acceptance testing of a coated particle composite.	27

Intentionally Left Blank

LIST OF TABLES

	Page
Table 1. Key variable properties of the AGR-1 TRISO fuel particles	6
Table 2. Key attribute properties of the AGR-1 TRISO fuel particles	7
Table 3. List of documents enabling irradiation testing of ORNL test rodlets in the ATR.....	16

Intentionally Left Blank

1. INTRODUCTION

The work documented in this report was performed under the Fuel Cycle Research and Development (FCRD) Program's Advanced Fuels Campaign (AFC) FY13 Work Package Number FT-13OR020222, revision 0, "Route to production and qualification of FCM fuel - ORNL." The sole milestone in this work package is M2FT-13OR020221, "Report Documenting Production Process, Thermophysical Properties, and QA Process to be Applied to First Irradiation Batch of FCM Fuels," due July 27, 2013. This report satisfies that milestone.

As described in Section 1.1 the overall purpose of this document is to provide a bridging Quality Assurance (QA) document internal to the FCRD program enabling the irradiation of test articles of interest to the program. These articles are to be fabricated at the Oak Ridge National Laboratory (ORNL) and passed to the Idaho National Laboratory (INL) for irradiation in the Advanced Test Reactor (ATR) as part of the Accident Tolerant Fuel (ATF) development effort designated the ATF-1 Test Series. These test articles include fully ceramic matrix fuel in zirconium alloy clad, as well as other potential fuel-clad systems under development including advanced steel clad and silicon carbide composite clad. The advanced steel and SiC test rodlets will each contain commercial UO₂ fuel. In each case these irradiation campaigns will represent first-time irradiation for these materials with experimental goals being irradiation stability, both in terms of dimensional stability and thermo-physical properties, as well as fuel-clad interaction. It is anticipated that post-irradiation evaluation will be carried out at hot-cell facilities at both the INL and ORNL with relevant information provided in this and other reports. This document specifically provides a high-level description of these test articles and a more rigorous description on the control and QA processes to be followed during the production of these articles.

1.1 DOCUMENT PURPOSE

The primary purpose of this report is to document the QA process to be used to ensure that the INL will accept the first batch of Fully Ceramic Microencapsulated (FCM) fuel, ATF FeCrAl/UO₂, and SiC/UO₂ to be fabricated by ORNL for the ATF-1 Test Series to be irradiated in INL's ATR. This document provides a general description of the fuel product fabrication method, the approach and anticipated documentation associated with acceptance testing of the test articles, the irradiation testing document structure, and the division of responsibility for the design and fabrication of the irradiation capsule and the execution of the irradiation test.

1.2 BRIEF DESCRIPTION OF FCM FUEL FORM AND PATH TO LEAD TEST ROD IRRADIATION IN A COMMERCIAL LWR

The FCM fuel form is being developed for Light Water Reactors (LWRs) to enhance the margin of safety in design basis accidents (DBA) and delay the threshold for fission product release during beyond-DBA conditions. FCM fuel is composed of TRI-structural-ISotropic (TRISO) fuel particles embedded in a SiC matrix to form a cylindrical fuel pellet envisioned to serve as a one-to-one replacement for current UO₂ fuel. The fuel pellet can be loaded into a standard zirconium alloy clad tube or any one of the high thermal-creep strength advanced oxidation-resistant cladding tubes (e.g. advanced steels, coated molybdenum, or SiC/SiC composite) currently under development in the AFC Accident Tolerant Fuel Development program. Qualification of a fuel-clad system for service in a commercial nuclear power plant is the responsibility of the fuel vendor with licensing of the fuel determined by the Nuclear Regulatory Commission (NRC) using a combination of Federal Regulations, regulatory guides, and evaluation of licensing topical reports. Of key interest to the current effort to support the eventual qualification and licensing of FCM fuel is the NRC's Standard Review Plan, specifically Section 4.2 Fuel

System Design [1] which describes the criteria that NRC staff intend to use in their evaluation of whether an applicant/licensee meets the NRC regulations. A critical element in the review process is the evaluation of technical data demonstrating satisfactory fuel performance under normal operating and postulated accident conditions. While the detailed NRC data requirements for licensing of nuclear fuel are well beyond the scope of this report, high-level areas of review include information on fuel design (e.g., description and drawings of the fuel assembly and components, specifications, experience, post irradiation examination), methods (codes, material properties, behavioral models), fabrication (processes and QA system) and testing. From a fuel centric perspective, the body of data needed to support licensing of a specific fuel-clad system begins with the development of the fuel, including the fabrication process and fundamental thermal and physical property measurements, and extends through stability and performance testing of fuel pins in the test reactor environment to fuel rod irradiation testing and fuel assembly irradiation testing in the commercial reactor environment. Irradiation testing in the ATR and subsequent post-irradiation examination (PIE) is expected to provide data needed to support a Lead Test Rod (LTR) irradiation in a commercial nuclear power plant (NPP) in ~2024. Successful LTR testing is expected to pave the way to Lead Test Assembly (LTA) testing in a commercial NPP. Figure 1 provides a visualization of the progression of the FCM fuel form from a TRISO particle in a SiC matrix to a fuel bundle.

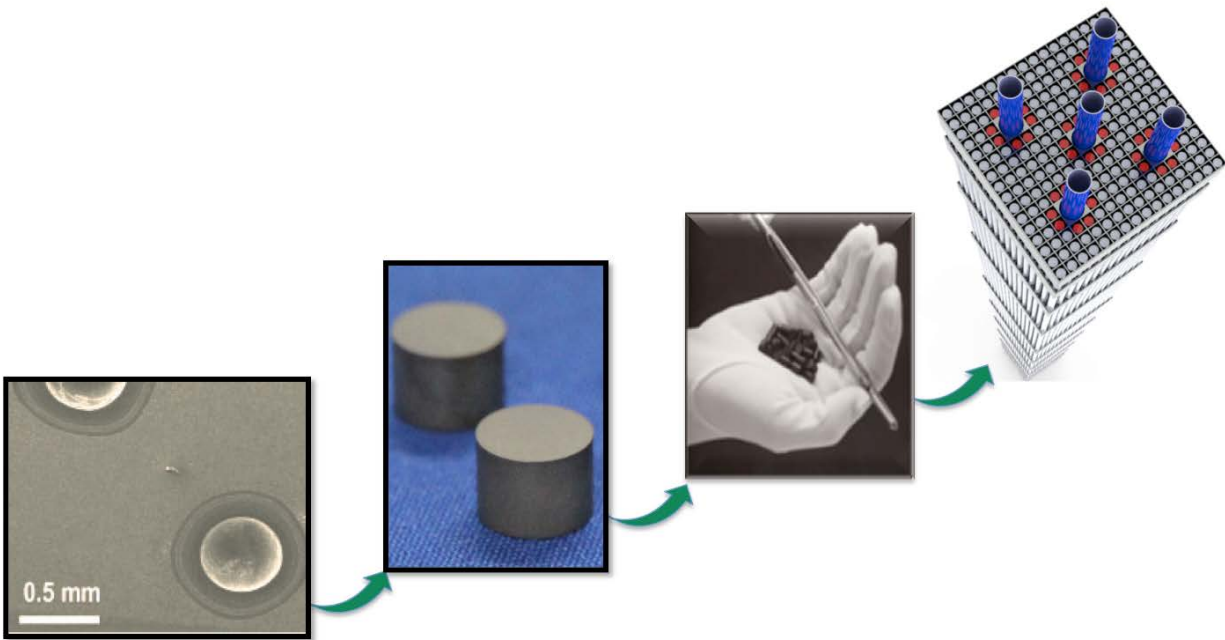

Fig. 1. Progression of the FCM fuel form from a TRISO particle in a SiC matrix to a LWR fuel bundle.

At the present time, the development of the FCM pellet fabrication process has reached the point where structurally sound pellets containing TRISO particles with packing fractions sufficient to provide linear heat generation rates and fuel temperatures approaching typical LWR service conditions have been fabricated. While the SiC matrix material is based on the Nano-infiltrated Transient Eutectoid (NITE) formulation of SiC developed to serve as an irradiation stable matrix for composites [2] and preliminary results from irradiation testing of FCM pellets with and without non-fueled (surrogate TRISO with ZrO₂ kernels) has indicated good irradiation stability [3] the irradiation performance of fueled FCM fuel pellets has not yet been examined. The principal goals of the first uranium fueled FCM pellet irradiation tests are to:

1. Measure the irradiation induced swelling of the FMC pellet under prototypic LWR conditions.
2. Provide information on pellet cracking, deformation, and physical and chemical interaction with clad materials.
3. Assess the thermochemical interaction of the UN kernel fission products with the SiC coating layer.

1.3 ALTERNATIVE FUEL CLAD DEVELOPMENT

The application of both SiC-SiC composite materials and advanced oxidation-resistant iron alloys has been proposed for use as nuclear fuel cladding in LWRs as a replacement for zirconium alloys [4, 5]. Within the AFC, work is presently underway supporting the development of both of these clad types owing to their potential advantages in terms of oxidation resistance and reduced hydrogen generation - as compared to zirconium alloys - in high temperature steam environments found in design basis loss-of-coolant accidents (LOCA) or beyond design basis station blackout accidents.

Nuclear grade SiC ceramic materials are being investigated for fuel cladding, channel box, and in-vessel components owing to their chemical inertness to very high temperatures, exceptional stability in harsh neutron irradiation environments, and high temperature strength [6, 7, 8, 9]. Work at ORNL is focused on the development of radiation tolerant joining technologies for SiC ceramics and composites with additional work underway on the development of fundamental properties data, fuel-clad chemical interaction data, and SiC mechanical property measurement standards development.

Two sets of SiC clad rodlets will be tested in the ATF-1 Test Series. The SiC clad rodlets will be assembled and sealed at ORNL in collaboration with Hypertherm HTC (now owned by Rolls Royce). SiC tubes and end caps will be fabricated by Rolls Royce and provided to ORNL under the existing Department of Energy Light Water Reactor Sustainability (LWRS) contract (Funding Opportunity Announcement or FOA) investigating the joining of SiC. Costs for materials are being born by the existing LWRS FOA contract. Commercial UO₂ fuel pellets will be placed into the Rolls Royce tubes and the end-caps sealed by two methods, one method provided by Rolls Royce and one method provided by the FCRD program. Tube sealing and associated leak and pressure testing will be carried out at ORNL prior to shipment to INL.

ORNL is also performing R&D to support the application of advanced oxidation resistant iron alloys for LWR clad applications. In particular, high temperature steam oxidation experiments [10, 11, 12, 13] with alumina- and chromia-forming iron alloys (FeCrAl) have led to the development of a high chromium ferritic alloy and a low chromium alloy. These alloys have been dubbed ORNL ATF FeCrAl-hiCR and FeCrAl-loCr and test rodlets utilizing these materials as cladding are slated for irradiation testing in the ATF-1 Test Series. The processes to fabricate thin wall tubing and perform seal welding are currently under development. The primary goals of the irradiation testing of these alloys are to acquire data on fuel-clad chemical and physical interaction and provide specimens for post irradiation examination.

1.4 EXPERIMENT MATRIX

The AFC has assigned INL the responsibility to irradiate candidate fuel and clad materials in the ATR to support development of accident tolerant fuel materials. While materials from several program participants are anticipated [14] only materials provided by ORNL are discussed here. INL is tasked with identifying test locations, performing experiment safety analyses, designing and building the experiment test fixtures for the irradiation testing, and developing the Experiment Safety Assurance Package (ESAP)

in preparation for ATR irradiation testing. The irradiation locations will be assigned based on the test objectives. The baseline design for the irradiation test capsule will be a drop-in capsule of the design previously used to conduct irradiation of fuel pins containing mixed oxide (MOX) fuel for the DOE Fissile Materials Disposition Program (FMDP). Figure 2 provides the proposed experiment matrix.

Fuel and Clad Type	Capsule Name	ATR Irradiation Cycles					
		1	2	3	4	5	6
FCM – AGR-1 TRISO, Zircaloy-4	FCM-AGR1						
	FCM-AGR2						
	FCM-AGR3						
FCM – UN TRISO, Zircaloy-4	FCM-UN1	-					
	FCM-UN2						
	FCM-UN3						
UO ₂ – FeCrAl-HfCr	FCA-HC1						
	FCA-HC2						
	FCA-HC3						
UO ₂ – FeCrAl-LoCr	FCA-LC1						
	FCA-LC2						
	FCA-LC3						
UO ₂ – SiC HyperTherm Joint	SiC-H1						
	SiC-H2						
	SiC-H3						
UO ₂ – SiC ORNL Joint	SiC-O1						
	SiC-O2						
	SiC-O3						
Cold Compact – TRISO UN, Zircaloy-4	CC-UN1	-					
	CC-UN2						
	CC-UN3						

Fig. 2. Matrix of currently proposed irradiation tests showing the fuel form, clad type, and number and timing of irradiation cycles.

2. ADVANCED CLAD IRRADIATION CAPSULES

As noted in Sections 1.3 and 1.4, SiC clad (two end cap sealing variants) and ORNL ATF FeCrAl iron alloy clad (high and low chromium variants) housing commercial UO₂ fuel are slated for irradiation testing. The test rodlets are intended to represent a miniature LWR fuel rod, will have nominally prototypic radial dimensions, will be fabricated at ORNL (He bonded), and will be shipped to the INL where the test rodlets will be sealed in 316L stainless steel capsules in preparation for insertion into the ATR [15]. The stainless steel capsule serves as the barrier between the test rodlet and the ATR coolant since the test rodlets are developmental in nature and can not be depended upon to ensure that fuel and fission products will not be released into the primary coolant where they could impede coolant flow or otherwise negatively impact reactor safety. It is important to note that the test rodlet outer diameter (O.D.) is fixed at 0.381 inches in order to provide for an appropriate gas gap (for temperature control) between the rodlet cladding O.D. and the capsule inner diameter. Approximately 76 commercially fabricated LWR UO₂ fuel pellets purchased from Westinghouse are available at ORNL for use in providing fuel for irradiation testing to examine the interaction of fuel with candidate advanced clad materials. The UO₂ fuel pellets were taken from a larger production run of Westinghouse pellets fabricated for commercial use in PWR fuel assemblies. Each pellet is nominally 0.323 inch O.D. × 0.387 inch long with dished ends. The UO₂ is 95% ± 1% theoretical density (10.98 g/cc) with 4.95 % ± 0.05% uranium-235 (U-235) enrichment.

3. FCM FUEL IRRADIATION CAPSULES

The fabrication of FCM fuel capsules is composed of first time fabrication of the FCM fuel form and then the fabrication of the test capsule. Fabrication of an FCM fuel pellet is performed in a series of steps, beginning with production of the uranium bearing microspheres and ending with grinding the final pellet form (right circular cylinder) to achieve the desired dimensions. A brief description of the entire fuel fabrication process is described in the following sections.

3.1 KERNEL FABRICATION

The microsphere at the center of the TRISO coated particle contains the fissile material and the fully sintered microsphere is typically called the fuel kernel. The kernel is produced using the internal gelation process, one of the sol-gel processes developed for the preparation of microspheres of nuclear fuel in which chilled clear broth droplets containing acid-deficient metal nitrate (ADMN), hexamethylenetetramine (HMTA), and urea are heated, causing homogenous gelation and solidification of the droplets [16]. After washing treatments, these droplets can then be dried, calcined, and sintered to produce ceramic kernels of the required density.

3.2 LWR TRISO COATING

The TRISO coatings are applied using chemical vapor deposition, a process by which gases or vapors are reacted or decomposed to produce solid layers. Fuel kernels are normally coated in a fluidized-bed using a vertical, high-temperature furnace. The carbon coatings (buffer, inner pyrolytic carbon (IPyC), and outer pyrolytic carbon (OPyC)) are deposited by cracking hydrocarbon gases such as propylene and acetylene mixed with an inert fluidizing gas such as argon. Silicon carbide is produced by the decomposition of methyltrichlorosilane (CH_3SiCl_3) with hydrogen as a reactant and fluidizing gas. Fluidization conditions, coating gas composition, and coating temperature are carefully controlled to produce coatings with microstructures and properties required to survive irradiation.

For the FCM-AGR1, -AGR2, and -AGR3 experiments, TRISO particles fabricated at ORNL for the historic Advanced Gas Reactor Fuel Development and Qualification (AGR) Program experiments will provide the fissile fuel. This fuel has demonstrated excellent performance during irradiation testing - under conditions anticipated for high temperature gas-cooled reactor operation - in the ATR for 610 full power days and is expected to provide sufficient fission heat to meet the FCM experiment goals at this stage.

Table 1 summarizes the key variable properties of the AGR-1 TRISO and Table 2 lists the upper limit of the 95% confidence interval of the defect fraction for key attribute properties of the AGR-1 TRISO fuel [17]. These values are the lowest tolerance limits for which the composite batch of AGR-1 TRISO was deemed acceptable at 95% confidence.

Table 1. Key variable properties of the AGR-1 TRISO fuel particles

Property	Mean
Average kernel diameter (μm)	349.7
Kernel envelop density (Mg/m^3)	10.924
Average buffer thickness (μm)	103.5
Average IPyC thickness (μm)	39.4
Average SiC thickness (μm)	35.3
Average OPyC thickness (μm)	41

Buffer envelope density (Mg/m ³)	1.10
IPyC sink/float density (Mg/m ³)	1.904
SiC sink/float density (Mg/m ³)	3.2075
OPyC sink/float density (Mg/m ³)	1.907
IPyC anisotropy (BAFo equivalent)	1.022
OPyC anisotropy (BAFo equivalent)	1.019

Table 2. Key attribute properties of the AGR-1 TRISO fuel particles

Property	Defect Fraction
Particles with SiC gold spot defects	$\leq 1.0 \times 10^{-3}$
Particle aspect ratio	$\leq 3.9 \times 10^{-3}$
Particles with burn-leach defects	$\leq 2.5 \times 10^{-5}$
Particles with missing OPyC	$\leq 9.6 \times 10^{-5}$

For FCM-UN1, -UN2, and -UN3, a specifically engineered LWR UN kernel TRISO compacted FCM fuel will be irradiated. For CC-UN1, -UN2, and -UN3, a cold compact (SiC matrix cold pressed, not fired) of UN fueled TRISO will be irradiated.

3.3 PELLET FABRICATION

The FCM fuel pellet is fabricated using a liquid phase sintering process known as the NITE process [18, 19] where the SiC matrix is formed around the TRISO particles. The starting material consists of SiC nanopowder blended with small quantities of oxide additives (Y₂O₃ and Al₂O₃ mixtures used as sintering aides) and TRISO particles that undergoes hot pressing.

3.3.1 Overcoating

In order to control the particle distribution within the pellets and eliminate detrimental particle-particle interaction an overcoating process is used to coat TRISO particles with NITE feedstock. This process, though considerably different in the details of its implementation, is consistent with the practices used for production of graphite matrix fuel compacts for High-Temperature Gas-cooled Reactors (HTGRs). For FCM pellet production a piezoelectric pump is used to spray a nanopowder slurry over fuel particles that are placed inside a rotating drum. The slurry consists of NITE feedstock powder produced by milling SiC and oxide additives inside an alcohol medium. The drum is heated during the process to enhance solvent evaporation. Using this process the particles are somewhat uniformly overcoated and the powder-to-particle mass ratio that determines the final particle packing fraction can be controlled.

3.3.2 Pellet Compaction

The overcoated particles are loaded into a steel die for cold compacting in the form of a tall pellet. The pressure during this step is controlled to avoid any particle damage. This cold compact forms the core region of the pellet. The core is then placed inside another cold compact in the shape of a sleeve. The sleeve is particle free and consists solely of NITE SiC powder. This structure is then loaded into a graphite die and NITE powder disk compacts are placed at each end.

3.3.3 Heat Pressing

The graphite die is placed inside a hot-press for pellet consolidation. The pressing takes place under inert atmosphere at temperatures up to 1900°C for the duration of 1 h. During the hot-pressing a pressure on

the order of 10 MPa is applied to the compact to enhance densification process. Upon completion of the hot-press the pellet is simply unloaded from the graphite die.

3.3.4 Grinding to Size

Once the hot-pressed pellets are produced, they need to be machined to meet the tight requirements on outer diameter. This is standard practice used for every UO_2 pellet that is used as commercial nuclear fuel. The machining apparatus consists of a computer controlled setup where a diamond grinding wheel is used to remove excess SiC material from the pellet. The pellet ends can be machined flat using the same setup. The tolerance demonstrated on the outer diameter of the pellets to date is $\pm 10 \mu\text{m}$.

4. THERMOPHYSICAL PROPERTIES OF FCM FUEL

The FCM fuel concept is still at an early stage of development and the final TRISO particle loading fraction of the FCM fuel to be tested in ATR under this program has not yet been determined, but is expected to be between 20 and 60 volume percent. ORNL will provide basic thermophysical properties of the FCM fuel to INL to support INL's work for safety analysis. The FCM fuel thermophysical property package will contain information from both the open literature and the unpublished ORNL internal research results. The properties provided will be given as functions of TRISO particle loading fraction, irradiation temperature and irradiation dose (when data is available). Below is the list of the properties that will be included in the FCM fuel thermophysical property package:

- Pre-irradiation density and thermal expansion
- Irradiation swelling
- Irradiated thermal conductivity
- Melting point
- Specific heat

5. QA PROCESS

5.1 DESCRIPTION OF QA APPROACH AND REQUIREMENTS

ORNL's QA approach for the gamut of technical pursuits comprising the work scope for the first irradiation batch of FCM is described in Document #QAP-ORNL-FCT-01 entitled *Quality Assurance Plan and Interface Document for Fuel Cycle Technology Research and Development Activities Conducted at Oak Ridge National Laboratory* [20] (hereafter referred to as the QAP). The QAP is established, maintained, and executed in accordance with the applicable criteria of the ORNL Quality Assurance Program Description, and is an enabling document for quality-related work associated with FCT activities to be conducted at ORNL or for ORNL by any subcontracted organizations. The ORNL QA program addresses the requirements contained in DOE Order 414.1D and in 10CFR830, Subpart A and is applied on a graded basis to all work activities at the site. ORNL's QA program also provides the flexibility and authorization to develop activity-specific programs to meet national and international quality standards and sponsor needs.

ORNL management recognizes that – though FCT activities are conducted as part of an ongoing R&D effort – successful outcomes represent potential inputs to future design and licensing decisions. The work scope described herein also requires interface with the ATR, a DOE nuclear facility. Therefore, activities shall be conducted under the QA rigor specified in both the ASME NQA-1-2008 with the NQA-1a-2009 Addendum (*Quality Assurance Requirements for Nuclear Facility Applications*, hereafter referred to as NQA-1-2008) standard and in the NRC-mandated 10CFR50 Appendix B (*Quality Assurance Criteria for Nuclear Power Plants and Fuel Reprocessing Plants*). ORNL management's intent is to ensure that this targeted quality program is satisfactory in addressing all FCRD work package milestones assigned to ORNL including those designated Quality Rigor Level 1 as described in the FCT's Quality Assurance Program Document (current version - Revision 2 effective December 20, 2012).

The requirements of the cited quality standards are imposed on a graded basis using the guidance contained in NQA-1-2008, Part IV, Subpart 4.2 (*Guidance on Graded Application of Quality Assurance for Nuclear-Related Research and Development*). Further, this plan is intended to meld the requirements contained in the previously cited national standards with those described in the FCT-issued Quality Assurance Program Document (QAPD). The FCT QAPD represents the highest-tier QA document specific to the FCT mission and applicable to the various work scopes, activities, and tasks funded at DOE-sponsored entities including ORNL.

For FCT activities conducted at ORNL, QA requirements are implemented by line and program management through a combination of the ORNL FCT QAP, associated subordinate QA procedures, and the mandates and requirements conveyed through the ORNL Standards Based Management System (SBMS). The SBMS is ORNL's web-based system for the translation and implementation of applicable laws, orders, and regulatory requirements through the deployment of Laboratory-wide subject areas and procedures. The QAP is intended, in part, to provide the framework for establishing and maintaining a QA program to fulfill the applicable requirements described in the NQA-1-2008 standard and in 10CFR50 Appendix B as they apply to FCT activities. The QAP – plus any additional referenced QA implementing procedures and SBMS documents necessary for conduct of the described work activities – constitute the ORNL FCT QA manual.

5.1.1 Activities Grading and Work Planning, Control, and Documentation Considerations

The management controls described in the ORNL QAP and in the associated implementing documents provide systems, processes, and tools that enable the ORNL FCT Program to deliver products that

effectively address the needs and requirements of the program sponsor. Quality controls shall be applied to the degree commensurate with the:

- function or end use of the publication, report, data/information set, item, service, or other final deliverable.
- consequence and probability of failure (risk) associated with the publication, report, data/information set, item, service, or other final deliverable.
- importance of the data or information being collected or analyzed.
- complexity of the equipment/software required to produce each deliverable.
- uniqueness of the deliverable or degree of standardization.
- degree to which functional compliance can be demonstrated through inspection or testing.

Activities that have the potential to impact the quality of the deliverables for which ORNL is responsible are defined as quality-affecting activities. As previously stated, the program shall provide control over quality-affecting activities to an extent consistent with their importance to results associated with the project deliverables and implementing the grading guidance provided in NQA-1-2008, Part IV, Subpart 4.2. For any future planned activities, the Program Manager (PM) and Principal Investigators (PIs), with the support of the Quality Representative (QR), determine whether work controlling documents are needed prior to the commencement of each associated activity.

Implementing documents applicable to the program scope of work shall translate the QAP requirements into work processes where the QAP does not do so directly. The ORNL FCT PM directs the activities and resources required to develop, proceduralize, and implement work controlling documents and is responsible to ensure that each PI and other staff members under their project purview consider the following elements during work planning activities:

- definition of the work scope, objectives, and a listing of the primary activities involved.
- identification and intended subsequent use of each associated deliverable.
- appropriate application of the QA requirements.
- definition of the necessary activities and how they are to be accomplished.
- identification or development of appropriate implementing documents.
- identification of equipment and software to be used.
- identification of prerequisites, special controls, environmental conditions, processes, or skills needed to complete planned work successfully.
- identification of applicable technical and management controls, required records, and verification activities.
- assignment of responsibilities.
- training and qualification.
- program closeout activities.

The technical activities undertaken to produce program deliverables are identified by program management and staff and are described in documents such as experimental/test plans, and other technical planning documents, or in the associated work breakdown structure including work package and milestone descriptions. These documents are expected to be modified to reflect changes in priorities and the course of work activities and are updated by new revisions of the original documents.

5.1.2 Identification and Control of Test Articles

Activities to ensure the correct identification and pedigree of test articles and their precursor materials and controls to ensure their traceability throughout fuel processing will be enacted for FCM kernel coating, particle pellet fabrication, and related characterization and acceptance testing activities. Test articles and any associated samples/specimens will be identified from their initial generation through final characterization and shipment to ensure that pedigree and traceability are established and maintained. Uncertainties in the test articles and samples due to past historical handling will be noted when and if they are encountered. Sample identification methods will include:

- physical marking or documentation of unique physical attributes through use of a defined numbering system;
- verification of cleanliness requirements;
- use of travelers, data sheets, and inspection plan reports throughout the processing steps including the use of a numbering system to maintain material traceability throughout all processing;
- physical separation;
- procedural control and logbook entries; and
- labels and tags on samples or containers.

For the subject FCM activities, control methods shall include tracing materials and test articles from their precursor components through final characterization using a numbering system that maintains traceability throughout all processing activities. Other controls shall include storage of items, materials, or test articles in labeled containers and storage in identified cabinets, hoods, or alternate locations. Physical marking, when used, will:

- be applied using materials and methods that provide clear and legible identification;
- not detrimentally affect the sample content or form;
- be transferred to each identified sample part when the sample is subdivided; and
- not be obliterated or hidden by surface treatments or sample preparations unless other means of identification are substituted.

Material identification and control activities shall ensure that test articles are directly traceable to the design specified in the applicable test article specification requirements.

Work control procedures shall specify and provide for the control of item or material identification consistent with the planned duration and conditions of storage. Considerations will include provisions for maintenance or replacement of markings and associated identification records due to damage during handling or aging; protection of identifications on items or materials subject to excessive deterioration

due to environmental exposure; and provisions for updating existing records. Items or materials having limited usefulness based on calendar time, operating life, or environmental conditions shall be identified and controlled to preclude use of items or materials whose shelf life or operating life has expired.

5.1.3 Data Package Compilation and Product Shipment

ORNL shall prepare a data package procedure that describes the actions necessary for effective capture and compilation of records, development of the data package, and the packing and shipping requirements associated with the planned transfer of final test pins containing the finished fuel pellets to INL. The basis for the data package shall be the product specifications and acceptance testing requirements contained in Section 4.4 of this document.

All records necessary to provide objective evidence of the successful completion of each step of the ORNL QA process and compliance with the associated product specifications shall be maintained. Each type of record required to substantiate product attributes and specification compliance shall be listed in the data package procedure. This list shall serve as the definitive content of the final data package. ORNL shall solicit INL's input to the data package procedure to ensure that all requirements necessary to facilitate irradiation in the ATR are accounted for and addressed.

5.1.4 Fabrication of Test Rodlets

Irradiation component design, manufacture, assembly, and testing at ORNL is performed by the Reactor and Nuclear Systems Division (RNSD). Activities associated with the design, fabrication, assembly, and pre-irradiation testing of test capsules are controlled in accordance with ORNL High Flux Isotope Reactor (HFIR) Procedure EG-1, latest revision, entitled *Review and Approval Process for HFIR In-Vessel and Gamma Irradiation Experiments* [21] and any additional procedures generated by the RNSD to address EG-1 requirements. HFIR is the responsibility of ORNL's Research Reactors Division (RRD). An electronic copy of EG-1 has been provided to INL's Kristine Barrett to assist with the development of program documents and EG-1 can be provided to any team member upon request to ORNL's project QA representative Mark Vance (vancemc@ornl.gov). INL can then use the current description of irradiation component controls enacted at ORNL as the basis for specifying acceptance criteria to address ATR requirements.

On the basis of the previously-described activities associated with design and development, ORNL applies the associated quality requirements on a graded basis as described in the site QA Program Description in the section entitled *Graded Approach*. Explicit requirements such as those related to ATR acceptance criteria will be used to establish the level of rigor necessary to support the planned work. Controlled test article configurations – most often defined in national or international standards and agreed to with the sponsor - shall be used in the machining of test articles.

Design and development stages for irradiation capsules are well defined through RNSD procedures. Capsule design review, verification, and validation requirements including the formulation of appropriate calculations for each development stage and the applicable responsibilities and authorities are governed by these procedures and by the requirements of RRD procedure EG-1. The interfaces among ORNL's R&D divisions, RNSD, and RRD are clearly defined in both RNSD and RRD procedures to facilitate effective communication and clear assignment of responsibility. RNSD - as the capsule design authority – updates and finalizes the capsule designs as development progresses.

The inputs applicable to capsule design are defined in both RNSD and RRD procedures. These inputs include:

- irradiation functional and performance requirements and associated performance calculations.
- applicable statutory and regulatory requirements governed through RRD as the reactor owner/operator organization.
- previous and often similar capsule designs. Most capsules currently planned or under irradiation have been verified for their adequacy over years of experience and through numerous cycles in the reactor.
- any other unique technical requirements that may be essential for effective design and development.

The RNSD and RRD procedures provide for the review for adequacy, and verification that requirements incumbent upon each capsule design are complete, unambiguous, and non-conflicting.

Outputs associated with capsule design and development are approved prior to release after verification against the design inputs. These outputs are explicitly verified to:

- meet the input requirements as defined by RNSD and verified by RRD for capsule design and development.
- provide appropriate information for the purchase of materials, sub-assembly production, capsule assembly and loading, and for any associated pre-irradiation inspections mandated by the design documents.
- define or reference capsule inspection points and acceptance criteria.
- specify the characteristics of each capsule design that are essential for its safe and compliant use in conformance to technical specifications and reactor operating requirements.

The same affected groups or organizations that reviewed and approved the original design documents shall approve any substantive design changes. Any change in organization causing a related change in ownership of the design shall include the designation of the new responsible organization.

The stages for systematic review of capsules designs are defined in RNSD and RRD governing procedures. These procedures explicitly require that design and development results be evaluated – first by RNSD personnel, and then by RRD as the reactor owner/operator – to ensure that the applicable technical and quality requirements are met prior to acceptance by RRD for subsequent irradiation. This evaluation also ensures that any associated problems are clearly identified and documented through the ORNL nonconformance control process. This process requires that applicable corrective or preventive actions be defined and addressed. The governing procedures clearly define the technical, management, and quality reviews required for this process, and each review is documented including any resulting actions. All final test rodlet data packages require two documented QA reviews prior to release to INL.

5.2 ATR EXPERIMENT ACCEPTANCE REQUIREMENTS

The as-built data package generated by ORNL will be evaluated by INL to determine whether the test articles meet ATR acceptance requirements. Appendix A of Hayes and Barrett [15] provides a summary of the requirements for acceptance of a drop-in capsule experiment of the type described in this

document. Early in the design and fabrication process, INL QA and the INL Fuel Cycle Technology Engineer will evaluate experiment materials and/or components to determine whether design mitigation is needed for ATR acceptance of the test rodlets. As previously noted, the purpose of this document is to provide advance information on the approach ORNL will use to ensure the test rodlets fabricated by ORNL will be accepted by INL for irradiation testing in the ATR. Both INL and ORNL clearly understand the expectation of the AFC sponsor that ORNL and INL will work closely together to ensure any impediments to acceptance are identified early and appropriate steps are taken to effect any changes in the test article design and fabrication process needed to support scheduled irradiation testing.

5.3 IRRADIATION TESTING DOCUMENT STRUCTURE

The family of documents to be used to plan and govern execution of the irradiation of test articles in the ATR is described in the following sections. The approach is patterned after prior irradiation testing conducted at the INL as well as the successful AGR-1 irradiation test where the fuel was fabricated at ORNL and shipped to INL where the multi-capsule test train, designed and fabricated at INL, was assembled and irradiated in the B-10 position of the ATR.

5.3.1 Program Documents

High-level program documents have been generated by the INL to describe the ATF-1 Test Series and provide planning guidance, define roles and responsibilities, and identify INL requirements associated with the preparation and execution of irradiation experiments in the ATR. Table 3 provides a quick reference table listing the current and planned documents to be used to enable project success.

Table 3. List of documents enabling irradiation testing of ORNL test rodlets in the ATR

Document Type	Title	Purpose	Document Number
Project Execution Plan – ATF Series	Project Execution Plan for the Fuel Cycle Research and Development LWR Fuels Irradiation Experiments in the ATR	Defines program objectives, technical and functional requirements, requirements for experiment fabrication and characterization, experiment irradiation details, provides team interface and responsibilities matrix, defines roles and responsibilities.	INL PLN-4401, Rev. 1 February 2013
Project Irradiation Test Plan – ATF Series	Irradiation Testing of Accident Tolerant Fuels in the ATR (The ATF-1 Test Series)	Describes program irradiation plan, defines test matrix, capsule design, and test conditions, responsibilities	INL PLN-4444, Rev. 0 April 2013
Irradiation Test Plan – ORNL specific	TBD	Provides conceptual planning to implement requirements from program planning documents and irradiation test specifications.	TBD - ORNL
Irradiation Test Specification	TBD	Defines the requirements for the irradiation phase of the experiments.	TBD - ORNL
Capsule Design and Fabrication	Not required – using existing design	Defines processes governing capsule design and defines fabrication requirements.	N/A
Fuel Product Specification and Acceptance Testing	TBD	Provides specific fuel product requirements necessary for acceptance of the fuel fabricated for irradiation testing.	TBD - ORNL

5.3.2 Irradiation Test Plan

The irradiation test plan will provide the conceptual planning needed to implement requirements from the technical program plan and the irradiation test specification (described in Section 4.3.2). This document will be produced by ORNL in partnership with INL and will provide the current state of planning for the first FCM irradiation experiment. This document will need to be periodically revised to capture the maturing details of the experiment since the fuel fabrication process is still under development and the physics and thermal design calculations being performed by INL are ongoing. The final revision of the test plan will be issued prior to the start of irradiation testing. The irradiation test plan envisioned is expected to look very much like the AGR-1 irradiation test plan [22].

The major elements of the irradiation test plan are as follows:

1. **Background**
This section will contain the test objectives and the experiment approach describing how the test objectives are to be achieved.
2. **Experiment Description**
This section will contain a detailed description of the test articles and the test train, including neutron and temperature diagnostics that may be included in the test train, any techniques used to tailor the neutron flux and spectrum, and the approach to be employed during a Powered Axial Locator Mechanism (PALM) cycle to ensure the heat generation and temperature limits of the experiment are not violated.
3. **Test Condition Requirements**
This section will describe the irradiation conditions expected for the ORNL test articles. The calculated particle power, temperature, fuel burnup, fast neutron fluence, and irradiation duration will be presented therein.
4. **Measurement Requirements**
This section will describe the measurements needed to demonstrate that the ORNL test articles achieve the irradiation goals and test specifications. These measurements may include neutron dosimetry, temperature measurements, and ATR data needed to assist physics analysis (e.g. fuel burnup, fast neutron fluence, and heat generation rates) and thermal analysis. ATR data may include core inlet temperatures, individual lobe powers, and shim cylinder positions. In addition, this section will address data acquisition, data storage, and data backup requirements and describe the method(s) to be used to validate the data and ensure it is qualified for use. Since the ATF-1 Test Series irradiations will use drop in capsules, there will be no sweep gas or fission gas release measurements required.
5. **Operational Requirements**
This section will describe the operational activities associated with the ORNL experiments. It will describe the pre-irradiation activities required prior to final test train assembly. This could include such work as confirmatory physics and thermal analyses using actual fuel acceptance testing data (dimensions, packing fraction, etc.), anticipated ATR operating conditions, and material properties data developed up to that time. Any post-assembly testing of the test train, measurement system calibration checks, and reviews needed to secure ATR experiment approval will be described. The activities required during conduct of the irradiation experiment will also be described. Examples include physics and thermal analyses to assess the potential effects of scheduled PALM cycles, periodic updates to the calculated burnup and fast neutron fluence taking into account cycle-to-cycle variations in the ATR lobe powers, and any physical

inspections of the test train that may be specified by the ATR (e.g. visual or dim dimensional inspection of the test train or the individual test pins) to ensure safe experiment and reactor operating conditions are maintained. This section should also specify what experiment data will be made available to the program participants, along with the format to be used, if possible. In addition, this section should describe the activities associated with the removal of the test train from the ATR following the completion of the irradiation or possibly, during a PALM cycle. This description should include cooling duration and reporting (e.g. a Quick Look Irradiation Test Results report and a Final Irradiation Test Results report. Results from PIE will be documented separately.

6. Safety and Quality Assurance

This section will describe the ORNL experiment requirements associated with the design, installation and operation of the irradiation test, the capsule containment tube, the mechanical design, nuclear materials accountability, and radioactive material shipments. It will describe the quality assurance compliance requirements associated with the overall ORNL ATF-1 Test Series experiments and any specific QA requirements associated with particular activities including, but not limited to, capsule design and review, capsule fabrication, operational procedures, computer software control for all activities with the potential to impact the success of the irradiation campaign, data management and validation, and reporting.

7. Irradiation Program Schedule

This section will contain the planned schedule for the experiment, including fabrication and characterization of the test articles, fabrication of the test train, irradiation, capsule cooling and disassembly, PIE, and test results reporting.

5.3.3 Irradiation Test Specification

The purpose of the irradiation test specification is to define the requirements for the irradiation phase of the ORNL assembled test rodlets. How the requirements are met will be described in the irradiation test plan (Section 4.3.1). Requirements pertaining to fuel fabrication, irradiation capsule design/fabrication/assembly/disassembly, PIE, and any other testing of the irradiated test articles subsequent to irradiation will be described elsewhere.

The irradiation test specification is expected to look very much like the AGR-1 irradiation test specification [23].

The major elements of the irradiation test specification are as follows:

1. Background

This section will provide background information and review the test objectives.

2. Test Capsule Requirements

This section will provide the requirements of the test capsule needed to provide the irradiation conditions necessary to meet the test objectives. At a minimum it will provide the requirements for the capsule design, the number of independent pins, required dosimetry, allowable material contact with the test articles, and allowable pellet-to-pellet contact.

3. Test Article Requirements

This section will specify what test articles are to be included in the ORNL ATF-1 Test Series irradiation tests and the configuration of the test articles. For example, FCM pellets produced using a specific variant of a baseline fuel fabrication process may be housed in a pin separate

from the baseline fuel. The fuel design parameters shall be listed in a table. Nominal parameters to be listed include kernel composition and U-235 enrichment, TRISO particle diameter, kernel diameter, and TRISO coating thicknesses, TRISO kernel and coating densities, U-235 loading per particle, total uranium loading per particle, pellet dimensions, number of TRISO particles per pellet, particle packing volume percent, U-235 loading per compact, and pellet matrix density.

4. Irradiation Test Condition Requirements

This section contains the required test conditions, specifically the peak temperature, time averaged peak temperature, time and volume averaged temperature, minimum pellet average burnup for each FCM pellet, the pellet average burnup goal for the majority of the fuel pellets, the minimum and maximum fast neutron fluence, and the instantaneous peak power per particle.

5. Test Operation Requirements

The LWR Fuels experiments are currently planned to be removed from the ATR during outages prior to PALM testing. Operational restrictions and limits will be identified in the LWR Fuels ESAP based on safety analysis results.

6. Test Measurement Requirements

This section will provide the requirements for recording and reporting ATF lobe powers, any special instructions for measurements during abnormal events, acceptable uncertainty on the end of irradiation neutron fluence determined by neutron monitors, and requirements on data acquisition sampling rate and test data backup and storage.

7. Documentation Requirements

This section will contain a list of reports to be generated and their frequency to ensure sufficient test information is disseminated in a timely manner. Examples of reports include informal status reports issued bi-weekly, as run data reports containing specified information (e.g. average burnup for each pellet, pellet averaged power per particle, etc.) at 50%, 75%, and 100% of test completion, a Quick Look Irradiation Test Results report issued within 6 weeks of test completion, a Final Irradiation Test Results report issued within 3 months of test completion.

5.3.4 Capsule Design and Fabrication

A separate capsule design and fabrication document is not anticipated for the ATF-1 Test Series because the test assembly is based on an existing design originally developed to test MOX fuels for the DOE FMDP [24-29]. This design is referred to by ATR designers/experimenters as the “MOX hardware” and has been used for a variety of tests at the INL to achieve prototypic LWR irradiation conditions. Since a new document is not expected to be generated, the following subsections are included for information purposes to ensure common understanding of the expectations associated with capsule design and fabrication.

5.3.4.1 Irradiation facility

The ATR test positions to be utilized for irradiation testing of the ORNL test rodlets will be determined by INL after appropriate consideration of the final test specifications and desired objectives. Based on the neutron and thermal flux characteristics and prior experience irradiating fueled experiments with representative LWR linear heat generation rates, it is anticipated that the small I positions and possibly the large B positions are the most likely candidates.

5.3.4.2 Capsule design and safety calculations

As previously noted, the baseline design for the irradiation test capsule will be a drop-in capsule of the design previously used to conduct irradiation of fuel pins containing MOX fuel. In this design, an experiment basket contains a total of 9 fuel pins in a configuration where 3 equally spaced holes in the azimuthal direction can each contain 3 vertically stacked fuel pins. Figure 3 shows the basketed assembly with three pins stacked vertically. Figure 4 presents a horizontal cross section showing the holes in the basket assembly, and Fig. 5 shows a single fuel pin. Therefore, a total of 9 fuel pins can be loaded into the basket assembly. INL and ORNL have agreed that ORNL will provide the sealed test rodlets and INL will provide the capsule and perform the capsule seal weld. In the case of the FCM fuel, the test rodlet will be composed of FCM fuel pellets in zirconium alloy clad. In the case of alternative clad materials, the clad tube will be loaded with commercial UO₂ fuel pellets.

ORNL will not produce any safety calculations. Per Barrett [14] no INL safety basis changes will be required for experiment fabrication and examination. INL will perform all neutronic, structural, and thermal analyses required to develop the capsules' ESAP. As noted in Section 4, ORNL will provide thermophysical properties data to support INL calculations.

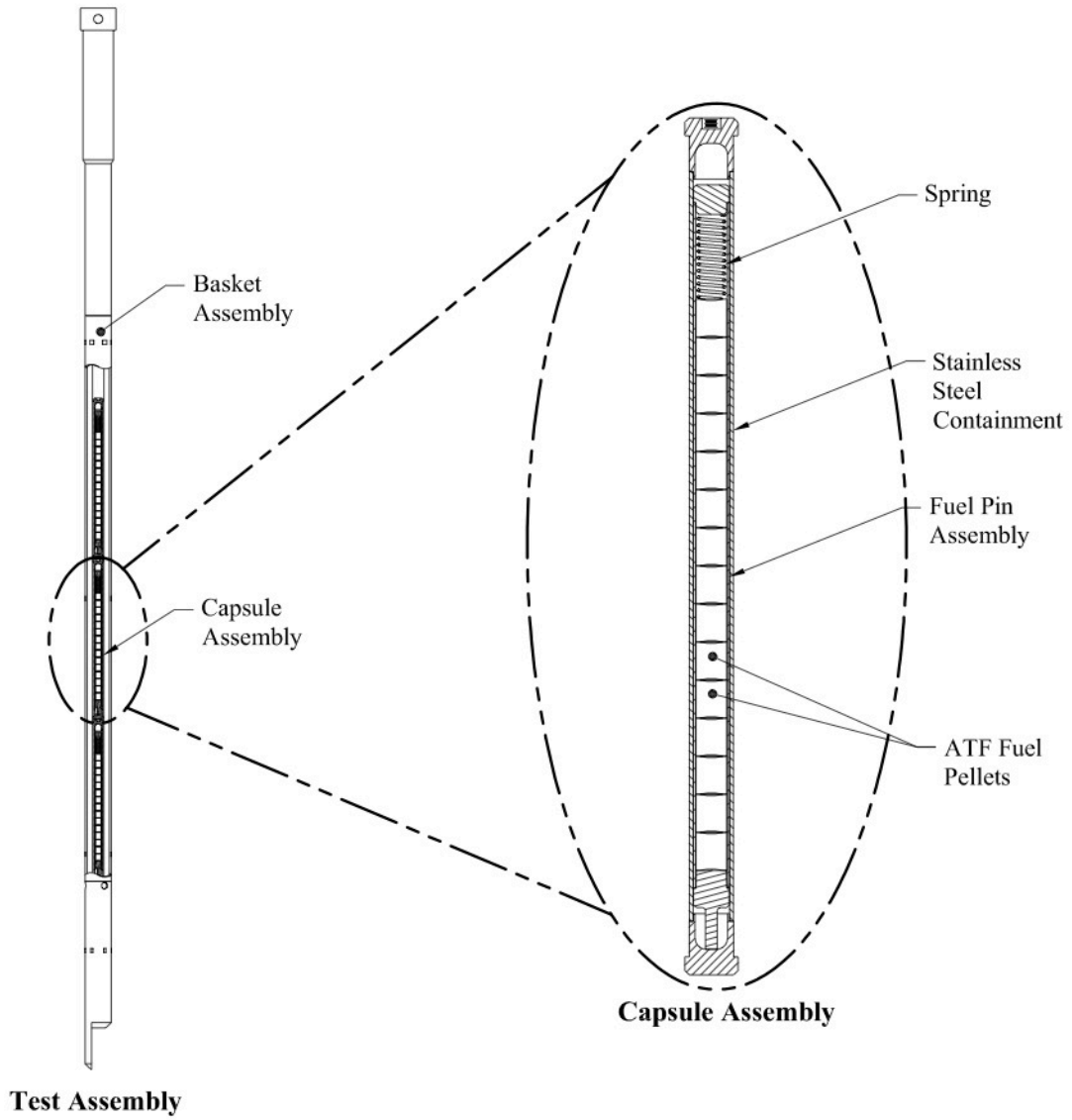

Fig. 3. Existing basket assembly to be adapted for use in the ATF-1 Test Series.

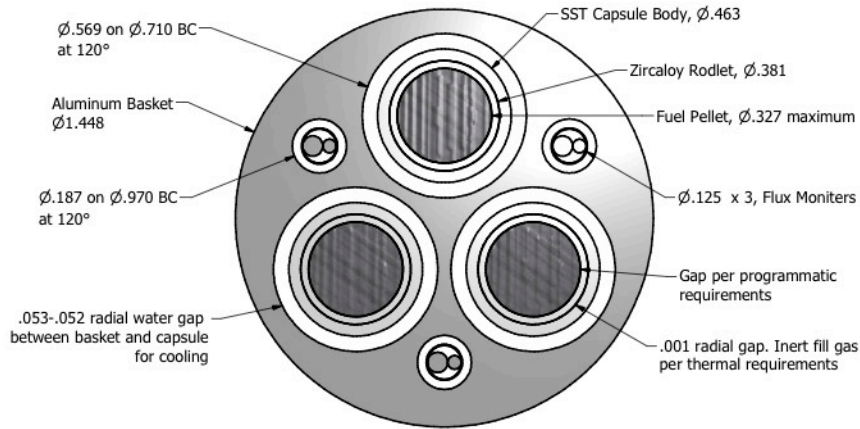

Fig. 4. Cross-section of existing basket assembly to be adapted for use in the ATF-1 Test Series.

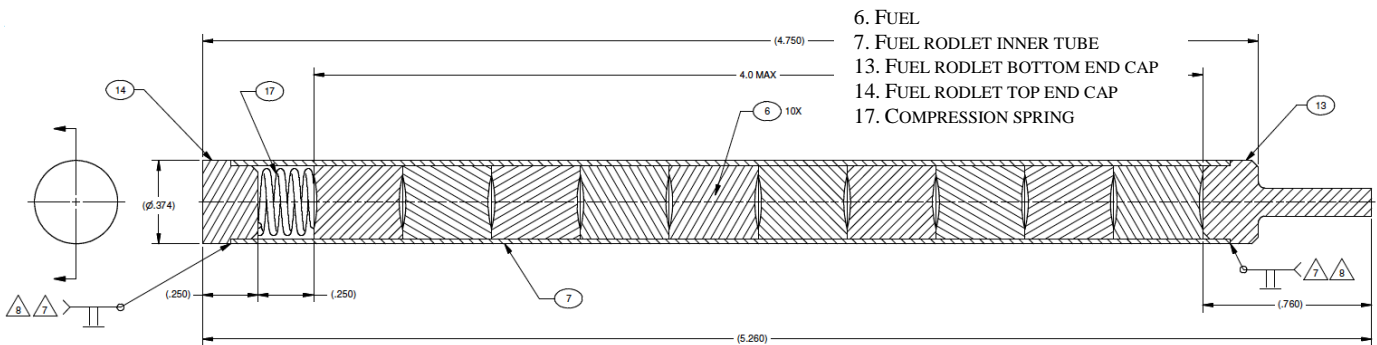

Fig. 5. Existing test capsule/rodlet configuration to be adapted for use in the ATF-1 Test Series (dimensions shown in inches).

5.3.4.3 Capsule fabrication

The test rodlet will be fabricated and assembled at ORNL. INL will fabricate the containment capsule components, and assemble the experiment capsule, with each capsule containing one fueled test rodlet suitable for ATR irradiation. The drawings to be used for the fabrication of the test rodlets will be mutually reviewed and agreed by ORNL and the INL prior to any fabrication or final safety analysis activity (excluding preliminary bounding calculations for program planning). As noted in Barrett [14], the INL principal investigator for Fuel Fabrication and Characterization has the responsibility to approve capsule and rodlet drawings. ORNL will not begin test rodlet fabrication until INL approval is documented. As previously noted, the test rodlets will be fabricated by ORNL and delivered to INL for encapsulation in a stainless steel capsule. The details of the capsule assembly are described by Hayes and Barrett [15].

5.3.5 Fuel Product Specification

The purpose of the fuel product specification document is to define the specific requirements necessary for acceptance of the fuel to be fabricated for the ATF-1 Test Series. For the FCM-AGR1, -2, and -3 experiments, the TRISO particles previously fabricated and accepted by INL for use in the AGR-1 irradiation test (AGR-1 TRISO) will be used for the fabrication of the fuel pellets. The published data reports for the AGR-1 TRISO will be referenced in the FCM data package. The fuel product specification document to be produced for the FCM fuel fabricated by ORNL will reference and be patterned after the AGR-1 fuel specification document [30].

The FCM-UN1, -2, and -3 test rodlets will contain FCM fuel pellets fabricated using a specifically engineered LWR TRISO particle with a UN kernel providing the fissile material.

The FCM fuel product specification document will need to be periodically revised to capture the maturing details of the fuel since the fuel fabrication process is still under development. The final revision of the FCM fuel product specification will be issued prior to the start of final acceptance testing of the fuel pellets. The specifications with +/- values will represent an allowable range for the mean (not the standard deviation of the specified value). The confidence level of the specified batch mean values shall be specified. Owing to the current early state of development, 95% confidence levels are not anticipated. The major elements of the fuel product specification are as follows:

1. Introduction

This section will provide background information and describe the contents of the document.

2. Quality Assurance

This section will provide the QA requirements governing the manufacturing, handling, and shipping of the fuel.

3. Fuel Kernel Specifications

This section will specify the kernel envelope density, diameter, sphericity and microstructure for individual kernel batches. The kernel composite will consist of multiple kernel batches combined and thoroughly mixed to ensure uniformity before sampling for acceptance testing. Kernel composite specifications shall include the U-235 enrichment (wt%), Nitrogen/uranium atomic ratio, oxygen/uranium atomic ratio, individual impurity content (e.g. Li, Na, Ca, V, Cr, Mn, Fe, Co, Ni, Cu, Zn, Al, and Cl (ppm-wt)), process impurities (e.g. P and S, ppm-wt), envelope density, diameter, total uranium (wt%), and sphericity (attribute property).

4. TRISO Coated Fuel Particle Specifications

This section will specify, at the coating batch level, the requirements to produce shape and size classified particles (sieving or rolling to remove undersize and oversize particles and tabling to remove aspherical particles). Batch specifications for coating thickness shall include variable properties such as buffer, IPyC, SiC, and OPyC thickness as well as attribute properties such as the fraction of particles with a missing IPyC layer.

Coated particle composites will normally include material from a number of batches. The composite quality control testing and analysis will be used to qualify the coated particle composite for irradiation testing. Fuel particle composite specification will include definition of the mean, critical region, and fraction of particle composite in the critical region, for variable properties such as coating layer thickness and density, and PyC layer anisotropy. Attribute properties such as aspect ratio, defective SiC fraction, missing OPyC layer defect fraction, particles with SiC gold spot fraction, and SiC microstructure shall also be specified.

5. Fuel Pellet Product Specification

This section will specify pellet fabrication process limits to ensure that the process (e.g. compaction or molding pressure, hot pressing pressure, heat treatment, etc.) does not damage the fuel particles being compacted and does not deviate from the acceptable range of process conditions determined during development. Specification for heat-treated pellets could include mean uranium loading, diameter, length, impurity metal content (e.g. Fe, Cr, Mn, Co, Ni, Ca, Al, Ti, V, Cl, etc.). Specification of chamfering around the pellet edges, acceptable cracking, chipping, surface finish and the like may also be provided. Attribute properties such as heavy metal contamination, defective SiC, IPyC, and OPyC coating fraction may be specified if practicable.

5.4 QUALITY CONTROL

Acceptance testing of the FCM fuel pellet will be performed using a product inspection plan. The procedures for characterizing and qualifying the fuel particles, and fuel compacts will be outlined in ORNL product inspection plans. The inspection report forms generated by the execution of the product inspection plans will document the product acceptance for the property requirements listed in the fuel product specifications. The inspection report forms are generated by procedures for a given measurement, called Data Acquisition Methods.

5.4.1 Product Inspection Plan

As noted above, a product inspection plan describes the inspections to be performed to characterize the product properties and attributes specified in the fuel product specification document. Figure 6 shows a schematic of a typical product inspection plan for a coated particle fuel composite while Hunn [31] provides the associated product inspection plan.

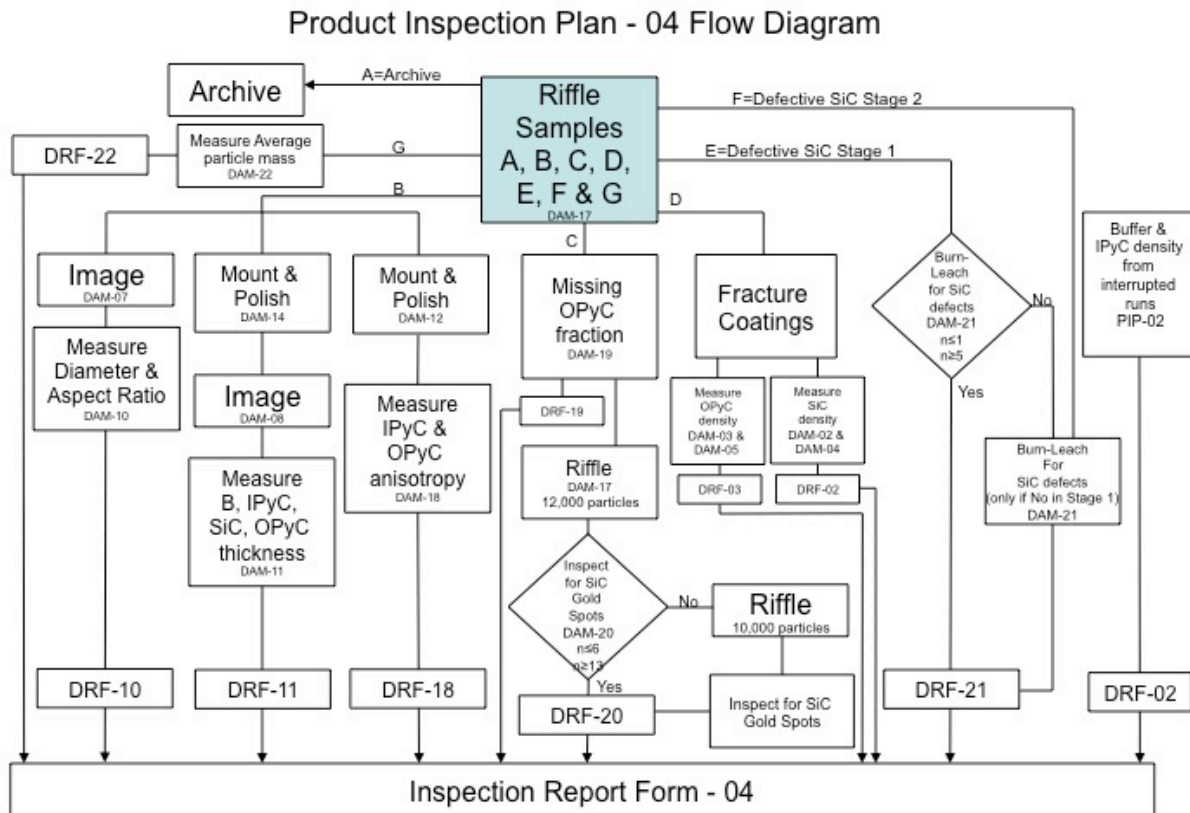

Fig. 6. Example flow diagram for an AGR Program product inspection plan.

5.4.2 Data Acquisition Methods

The data acquisition methods called out in the product inspection plan are used to document the method and procedure used to perform a given measurement of a property or attribute. Hunn [32] is an example of a data acquisition method procedure used to measure the density of a TRISO pyrocarbon layer using a density gradient column. The execution of DAM-03 produces the data used to populate the Data Report Form DRF-03. An example of a data report form from Hunn and Lowden [33] is shown in Fig. 7.

Data Report Form DRF-03: Measurement of PyC Density using a Density Gradient Column			
Procedure: AGR-CHAR-DAM-03 Rev. 1			
Operator: Dixie Barker			
Filename: \\mc-agr\AGR\DensityColumn\D05063001_DRF03R1.xls			
Sample ID: NUCO350-37BI-B			
Sample Description: IPyC/Buffer on BWXT kernel composite 69300			
Float Expiration Date: 07/2007			
Gauge Expiration Date: 01/2006			
Bath Temperature: 22.9C			

Calibrated Floats			
Density	Top of Float	Bottom of Float	Center of Mass
1.800	151.98	161.42	156.70
1.850	262.34	270.69	266.52
1.900	370.32	376.20	373.26
1.950	473.40	480.73	477.07
2.000	569.44	576.52	572.98

Linear Fit			
slope	StDev	intercept	StDev
4.79E-04	2.94E-06	1.72E+00	1.17E-03

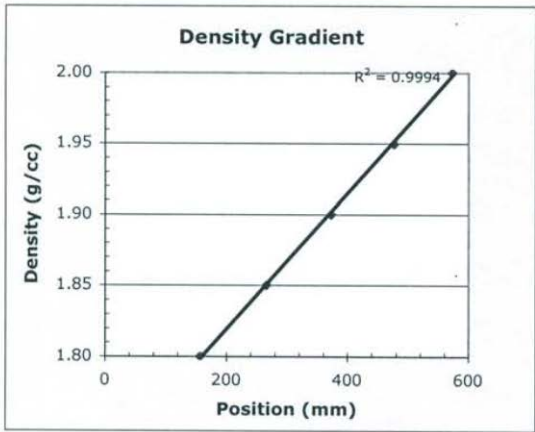

Density Gradient

$R^2 = 0.9994$

Sample Density			
Particle Number	Particle Position	Calculated Density	Standard Error
1	313.15	1.8731	0.0015
2	329.08	1.8807	0.0015
3	335.13	1.8836	0.0015
4	342.49	1.8872	0.0015
5	349.04	1.8903	0.0016
6	351.34	1.8914	0.0016
7	365.21	1.8980	0.0016
8	367.09	1.8989	0.0016
9	367.27	1.8990	0.0016
10	378.19	1.9043	0.0016
11	382.30	1.9062	0.0016
12	386.45	1.9082	0.0016
13	387.67	1.9088	0.0016
14	389.34	1.9096	0.0016
15	390.40	1.9101	0.0016
16	404.73	1.9170	0.0017
17	409.36	1.9192	0.0017
18	412.62	1.9207	0.0017
19	412.95	1.9209	0.0017
20	418.50	1.9236	0.0017
21	428.34	1.9283	0.0017
22			
23			
24			
25			
Average Density		1.9038	0.0004
Standard Deviation		0.0153	

Dixie Barker
Operator

6-30-05
Date

Fig. 7. Representative Data Report Form used to document acceptance testing of the PyC density.

5.4.3 Inspection Report Form

The end product of a product inspection plan is an Inspection Report Form. The inspection report form is used to summarize data from the various inspections and to document the acceptability of the fuel product as specified by the fuel product specification document. Figure 8 is a representative inspection report form [33].

Inspection Report Form IRF-04A: Coated Particle Composites									
Procedure: AGR-CHAR-PIP-04 Rev. 2									
Coated particle composite ID: LEU01-46T									
Coated particle composite description: Baseline Composite: TRISO on BWXT kernel composite 69302									
Property	Measured Data			k or t value	Specification INL EDF-4380 Rev. 6	Acceptance Criteria	Acceptance Test Value	Pass or fail	Data Records
	Mean (x)	Std. Dev. (s)	# measured (n)						
Average buffer thickness for each particle (µm)	103.5	8.2	213	1.652	mean 100 ± 15	A = x - ts/√n ≥ 85	102.6	pass	DRF-08 DRF-11
				2.560	dispersion ≤0.01 ≤ 55	B = x + ts/√n ≤ 115	104.4	pass	
Average IPyC thickness for each particle (µm)	39.4	2.3	233	1.651	mean 40 ± 4	A = x - ts/√n ≥ 36	39.2	pass	DRF-08 DRF-11
				2.549	dispersion ≤0.01 ≤ 30 ≤0.01 ≥ 56	B = x + ts/√n ≤ 44	39.6	pass	
Average SiC thickness for each particle (µm)	35.3	1.3	233	1.651	mean 35 ± 3	A = x - ts/√n ≥ 32	35.2	pass	DRF-08 DRF-11
				2.549	dispersion ≤0.01 ≤ 25	B = x + ts/√n ≤ 38	35.4	pass	
Average OPyC thickness for each particle (µm)	41.0	2.1	233	1.651	mean 40 ± 4	A = x - ts/√n ≥ 36	40.8	pass	DRF-08 DRF-11
				2.549	dispersion ≤0.01 ≤ 20	B = x + ts/√n ≤ 44	41.2	pass	
Buffer envelope density	See IRF-02A							pass	IRF-02A
IPyC sink/float density	See IRF-02B							pass	IRF-02B
SiC sink/float density (Mg/m³)	3.2075	0.0032	40	1.685	mean ≥ 3.19	A = x - ts/√n ≥ 3.19	3.207	pass	DRF-02
				2.941	dispersion ≤0.01 ≤ 3.17	C = x - ks > 3.17	3.198	pass	
OPyC sink/float density	See IRF-04B								IRF-04B
IPyC anisotropy (BAFo equivalent)	1.022	0.002	10	1.833	mean ≤ 1.035	B = x + ts/√n ≤ 1.035	1.023	pass	DRF-18
				3.981	dispersion ≤0.01 ≥ 1.06	D = x + ks < 1.06	1.030	pass	
OPyC anisotropy (BAFo equivalent)	1.019	0.003	10	1.833	mean ≤ 1.035	B = x + ts/√n ≤ 1.035	1.021	pass	DRF-18
				3.981	dispersion ≤0.01 ≥ 1.06	D = x + ks < 1.06	1.031	pass	
Particles with SiC gold spot defects			81507		defect fraction ≤ 1.0 × 10 ⁻³	≤6 in 12,000 or ≤14 in 22,000	66	pass	DRF-20
Particle aspect ratio			1626		dispersion ≤0.01 ≥ 1.14	≤1 in 500 or ≤7 in 1420	2	pass	DRF-07 DRF-10
Particles with SiC burn-leach defects			120688		defect fraction ≤ 1.0 × 10 ⁻⁴	≤1 in 50,000 or ≤6 in 120,000	0	pass	DRF-21
Particles with missing OPyC			31227		defect fraction ≤ 3.0 × 10 ⁻⁴	≤4 in 31,000	0	pass	DRF-19
SiC microstructure			3		comparison to visual standard	all imaged pass visual standard comparison	3	pass	DRF-23

Comments

66 out of 81507 gold spot defects passes the acceptance criterion of ≤66 in 81100 indicating ≤1E-3 defects with 95% confidence.



 QC Supervisor	3-21-06 Date
Accept coated particle composite (Yes or No): Yes	
 QA Reviewer	3/29/06 Date

Fig. 8. Representative Inspection Report Form used to document acceptance testing of a coated particle composite.

5.4.4 Final Data Package

The final data package will comprise the ORNL Certificates of Conformance and Data Compilation Reports. A certificate of conformance is a standard form issued by the FCR&D Quality Representative composed of 6 sections:

1. Item Identification
2. Part Lot and Lot Number
3. Product Definition
4. List of Approved Deviations
5. List of Applicable Nonconformance Report Numbers

The Data Compilation Report is a compilation of the various inspection report forms and summary text typically including a description and documentation of the material flow and quick reference tables for key variable properties and key attribute properties of the fuel. An example Certificate of Conformance is shown in Appendix A. An example Data Compilation Report is provided by Hunn and Lowden [33].

6. REFERENCES

1. NUREG-0800 Revision 3, U.S. Nuclear Regulatory Commission, March 2007.
2. Y. Katoh, S. M. Dong, A. Kohyama, "Thermo-mechanical Properties and Microstructure of Silicon Carbide Composites Fabricated by Nano-infiltrated Transient Eutectoid Process," *Fus. Eng. and Design*, **61**, (2002), 329.
3. L.L. Snead, et al., "Stability of SiC matrix microencapsulated fuel constituents under relevant LWR conditions," *J. Nucl. Mat.*, in preparation, (2013).
4. K. A. Terrani, S. J. Zinkle, and L. L. Snead, "Advanced Oxidation-Resistant Iron-Based Alloys for LWR Fuel Cladding," *J. Nucl. Mat.*, doi:10.1016/j.jnucmat.2013.06.041, (2013).
5. S. Bragg-Sitton, "Advanced LWR Nuclear Fuel Cladding System Development Technical Program Plan," Light Water Reactor Sustainability Program, U.S. Department of Energy. Idaho Falls, ID: Idaho National Laboratory, 2012. External Report. INL/MIS-12-25696.
6. Y. Katoh, K. Ozawa, C. Shih, T. Nozawa, R. J. Shinavski, A. Hasegawa, and L. L. Snead, "Continuous SiC Fiber, CVI SiC Matrix Composites for Nuclear Applications: Properties and Irradiation Effects," submitted to *J. Nucl. Mat* April 2013.
7. K. Yueh, D. Carpenter, H. Feinroth, "Clad in Clay," *Nucl. Eng. Int.*, **55**, (2010) 14-16.
8. K.E. Barrett, M.P. Teague, I. van Rooyen, S. Bragg-Sitton, K. Ellis, C. Glass, G. Roth, K. McHugh, J. Garnier, G. Griffith, M.C. Teague, G. Bell, L.L. Snead, Y. Katoh, "Engineering Challenges of LWR Advanced Fuel Cladding Technology in Preparation for In-Reactor Demonstration," *Trans. Amer. Nucl. Soc.*, **107**, (2012) 886-889.
9. C. P. Deck, H. E. Khalifa, B. Sammulu, T. Hilsabeck, C. A. Back, "Fabrication of SiC-SiC composites for fuel cladding in advanced reactor designs," *Prog. Nucl. Energy*, **57**, (2012), 38-45.
10. B.A. Pint, K.A. Terrani, M.P. Brady, T. Cheng, J.R. Keiser, *J. Nucl. Mater.* in press (2013).
11. T. Cheng, J.R. Keiser, M.P. Brady, K.A. Terrani, B.A. Pint, *J. Nucl. Mater.* **427**, (2012) 396.
12. B.A. Pint, M.P. Brady, J.R. Keiser, T. Cheng, K.A. Terrani, "High Temperature Oxidation of Fuel Cladding Candidate Materials in Steam-Hydrogen Environments," Proceedings of the 8th International Symposium on High Temperature Corrosion and Protection of Materials, Les Embiez, France, 2012.

13. K. A. Terrani, C. M. Parish, D. Shin, B. A. Pint, "Protection of zirconium by alumina- and chromia-forming iron alloys under high temperature steam exposure," *J. Nucl. Mater.* **438**, (2013) 64-71.
14. K. Barrett, "Project Execution Plan for the Fuel Cycle Research and Development LWR Fuels Irradiation Experiments in the ATR," PLN-4401, Idaho National Laboratory, February 2013.
15. S. L. Hayes and K. E. Barrett, "Irradiation Testing of Accident Tolerant Fuels in the ATR (The ATF-1 Test Series)," INL Document PLN-4444, April 2013.
16. R. D. Hunt and J. L. Collins, "Uranium Kernel Formation Via Internal Gelation," *Radiochim. Acta*, **92**, (2005) 909.
17. J. D. Hunn and R. A. Lowden, "Data Compilation for AGR-1 Baseline Coated Particle Composite LEU01-46T," ORNL/TM-2006/019, Rev. 1
18. Y. Katoh, A. Kohyama, T. Nozawa, and M. Sato., *J. Nucl. Mater.* **329-333**, (2004) 587-591.
19. K. A. Terrani, J. O. Kiggans, Y. Katoh, K. Shimoda, F. C. Montgomery, B. L. Armstrong, C. M. Parish, T. Hinoki, J. D. Hunn, and L. L. Snead, "Fabrication and characterization of fully ceramic microencapsulated fuels,": *J. Nucl. Mater.* **426**, (2012) 268-276.
20. ORNL Document #QAP-ORNL-FCT-01, "Quality Assurance Plan and Interface Document for Fuel Cycle Technology Research and Development Activities Conducted at Oak Ridge National Laboratory," latest revision July 2013.
21. Research Reactors Division Procedure, EG-1, "Review and Approval Process for HFIR In-Vessel and Gamma Irradiation Experiments," (2009).
22. J. T. Maki, AGR-1 Irradiation Experiment Test Plan, INL/EXT-05-00593, August 2005.
23. J. T. Maki, "AGR-1 Irradiation Test Specification," EDF-4731, Rev. 11, July 2004.
24. L. J. Ott and R. N. Morris, "Irradiation Tests of Mixed-Oxide Fuel Prepared with Weapons-Derived Plutonium," *J. Nucl. Mater.* **371**, (2007) 314-328.
25. K. R. Thoms, "Design, Functional, and Operational Requirements for the Advanced Test Reactor Mixed Oxide Fuel Irradiation Experiment ORNL/MD/LTR-76, Rev. 1, September 1997.
26. L. J. Ott, "Thermal/Hydraulic Calculations for the LWR MOX Irradiation Test Assembly at 12 kW/ft," ORNL/MD/LTR-85, October 1997.
27. J. E. Corum and K. H. Luk, "Design Calculations in Support of the Advanced Test Reactor Mixed Oxide (ATR-MOX) Fuel Irradiation Experiment," ORNL/MD/LTR-92, November 1997.

28. L. J. Ott, "Thermal/Hydraulic Calculations for Phase IV of the LWR MOX Irradiation Average-Power Test," ORNL/MD/LTR-191, July 2000.
29. C. Luttrell and T. Yahr, "Design Calculations for Phase IV of the Advanced Test Reactor Average-Power Mixed Oxide Fuel Irradiation Experiment," ORNL/MD/LTR-192, August 2000.
30. C. M. Barnes, "AGR-1 Fuel Product Specification and Characterization Guidance," INL Document EDF-4380 Rev. 8, April 2006.
31. J. D. Hunn, "Product Inspection Plan Coated Particle Composites," AGR-CHAR-PIP-04, Rev. 2, November 8, 2005.
32. J. D. Hunn, "Data Acquisition Method Measurement of PyC Density using a Density Gradient Column," AGR-CHAR-DAM-03, Rev. 2, September 20, 2005.
33. J. D. Hunn and R. A. Lowden, "Data Compilation for AGR-1 Baseline Coated Particle Composite LEU01-46T," ORNL/TM-2006/019, Rev. 1, April 2006.

Intentionally Left Blank

APPENDIX A.
ORNL CERTIFICATE OF CONFORMANCE

Intentionally Left Blank

APPENDIX A. ORNL CERTIFICATE OF CONFORMANCE

Example of an ORNL Certificate of Conformance taken from the ORNL document “Final Data Packages for AGR-1 Fuel Compacts, Rev. 1, Book 1 of 2, Includes Final Data Packages for: Baseline – Lot LEU01-46T-Z and Variant 1 – Lot LEU01-47T-Z,” September 20, 2006.

**Oak Ridge National Laboratory
Advanced Gas Reactor Fuel Development and Qualification Program
CERTIFICATE OF CONFORMANCE**

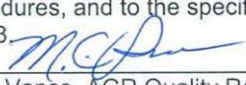
<p>1. ITEM IDENTIFICATION: AGR Fuel 2. PART LOT AND LOT NUMBER: Baseline LEU01-46T-Z 3. PRODUCT DEFINITION: a) INL EDF-4380 and b) INL EDF-4542 (Applicable revisions indicated on product Inspection Report Forms contained in Section #3 of data package) 4. LIST OF APPROVED DEVIATIONS (Deviation forms attached in Section #5 of data package): Not applicable</p>									
*Part Type	Unique Part I.D. No.	QTY	INIT.	Date	*Part Type	Unique Part I.D. No.	QTY	INIT.	Date
FC	05	1	MW	8/31/06	FC	39	1	MW	8/31/06
FC	07	1			FC	42	1		
FC	09	1			FC	43	1		
FC	12	1			FC	44	1		
FC	14	1			FC	46	1		
FC	15	1			FC	49	1		
FC	17	1			FC	52	1		
FC	19	1			FC	53	1		
FC	23	1			FC	55	1		
FC	24	1			FC	56	1		
FC	30	1			FC	57	1		
FC	32	1			FC	58	1		
FC	33	1			FC	60	1		
FC	34	1			FC	62	1		
FC	36	1			FC	65	1		
<p>5. LIST OF APPLICABLE NONCONFORMANCE REPORT NUMBERS (NCRs attached in Section #5 of data package): NCR-X-AGR-06-03, NCR-X-AGR-06-05 With the exception of the Deviations documented on the forms referenced in Item 4 and the nonconforming conditions documented on Nonconformance Reports referenced in Item 5, the listed parts have been produced and tested in compliance to the requirements of the QAP for the AGR Program at ORNL (Document # QAP-ORNL-AGR-01), its subordinate implementing procedures, and to the specified product definition prescribed in the document(s) referenced in Item 3.</p> <p align="right">  8/31/06 M. C. Vance, AGR Quality Representative Date Materials Science and Technology Division, ORNL </p>									

* FC indicates fuel compact

**Oak Ridge National Laboratory
Advanced Gas Reactor Fuel Development and Qualification Program
CERTIFICATE OF CONFORMANCE**

1. **ITEM IDENTIFICATION:** AGR Fuel
 2. **PART LOT AND LOT NUMBER:** Baseline LEU01-46T-Z
 3. **PRODUCT DEFINITION:** a) INL EDF-4380 and b) INL EDF-4542 (Applicable revisions indicated on product Inspection Report Forms contained in Section #3 of data package)
 4. **LIST OF APPROVED DEVIATIONS** (Deviation forms attached in Section #5 of data package): Not applicable

*Part Type	Unique Part I.D. No.	QTY	INIT.	Date	*Part Type	Unique Part I.D. No.	QTY	INIT.	Date
FC	67	1	<i>MEJ</i>	<i>8/3/06</i>					
FC	69	1							
FC	76	1							
FC	77	1							
FC	78	1							
FC	79	1							

5. **LIST OF APPLICABLE NONCONFORMANCE REPORT NUMBERS (NCRs attached in Section #5 of data package):** NCR-X-AGR-06-03, NCR-X-AGR-06-05

With the exception of the Deviations documented on the forms referenced in Item 4 and the nonconforming conditions documented on Nonconformance Reports referenced in Item 5, the listed parts have been produced and tested in compliance to the requirements of the QAP for the AGR Program at ORNL (Document # QAP-ORNL-AGR-01), its subordinate implementing procedures, and to the specified product definition prescribed in the document(s) referenced in Item 3.

M. C. Vance
 M. C. Vance, AGR Quality Representative
 Materials Science and Technology Division, ORNL

8/3/06
 Date

* FC indicates fuel compact Data Package Page 4