



BNL-94936-2011-CP

NSLS-II RF SYSTEMS

J. Rose, W. Gash, B. Holub, Y. Kawashima, H. Ma, N. Towne, M. Yeddulla

Presented at the 2011 Particle Accelerator Conference (PAC'11)
New York, NY
March 28-April 1, 2011

March 2011

Photon Sciences Directorate
Brookhaven National Laboratory

U.S. Department of Energy
DOE - Office of Science

Notice: This manuscript has been authored by employees of Brookhaven Science Associates, LLC under Contract No. DE-AC02-98CH10886 with the U.S. Department of Energy. The publisher by accepting the manuscript for publication acknowledges that the United States Government retains a non-exclusive, paid-up, irrevocable, world-wide license to publish or reproduce the published form of this manuscript, or allow others to do so, for United States Government purposes.

This preprint is intended for publication in a journal or proceedings. Since changes may be made before publication, it may not be cited or reproduced without the author's permission.

DISCLAIMER

This report was prepared as an account of work sponsored by an agency of the United States Government. Neither the United States Government nor any agency thereof, nor any of their employees, nor any of their contractors, subcontractors, or their employees, makes any warranty, express or implied, or assumes any legal liability or responsibility for the accuracy, completeness, or any third party's use or the results of such use of any information, apparatus, product, or process disclosed, or represents that its use would not infringe privately owned rights. Reference herein to any specific commercial product, process, or service by trade name, trademark, manufacturer, or otherwise, does not necessarily constitute or imply its endorsement, recommendation, or favoring by the United States Government or any agency thereof or its contractors or subcontractors. The views and opinions of authors expressed herein do not necessarily state or reflect those of the United States Government or any agency thereof.

NSLS-II RF SYSTEMS

J. Rose, W. Gash, B. Holub, Y. Kawashima, H. Ma, N. Towne, M. Yeddulla
BNL, Upton, NY 11073, U.S.A.

Abstract

The NSLS-II is a new third generation light source being constructed at Brookhaven Lab. The storage ring is optimized for low emittance by use of damping wigglers to reduce the emittance to below 1 nm-rad. The RF systems are designed to provide stable beam through tight RF phase and amplitude stability requirements

INTRODUCTION

The NSLS-II will produce x-ray beams with less than 1 nm-rad emittance. This will be achieved partly by adoption of a large circumference, allowing weak dipoles to reduce the quantum excitation of the beam and incorporating damping wigglers to reduce emittance. In order for users to make use of the smaller beam size, the longitudinal and transverse jitter must be proportionally smaller than in existing machines. Studies [1] have derived the limits on the RF phase and amplitude stability to be < 0.15 degrees phase and 0.05% amplitude deviations. The injector RF systems, while not contributing to the stored beam emittance, require high precision and low noise to minimize beam loss. To achieve these goals the RF system is designed with an ultra low noise master oscillator as the source, and every effort is made to preserve this low noise through the amplifier-cavity chain. Fast feedbacks are used to combat the effects of cavity microphonics on field quality. The NSLS-II ring has a beam lifetime dominated by the Touschek scattering, calculated to be 2 hours. In order to increase the lifetime to greater than 3 hours, which will allow top off injections and the resultant perturbation to stored beam to be one a 1 minute or longer, a passive, third harmonic cavity is required to lengthen the bunches and increase lifetime. The NSLS-II RF systems include the linac, booster and storage ring systems as well the Liquid liquid Helium helium and nitrogen cryogenic systems. Each of these will be briefly described along with their design approach to minimize noise on the beam.

GLOBAL SYSTEMS

Master Oscillator and Clock Generation

The Master Oscillator (MO) is an Agilent E8257D-UNIX ultra low phase noise signal generator with phase continuous frequency modulation. The frequency modulation is software programmable and will be used in a beam radial loop to correct for diurnal and annual changes in the orbit due to changes in the path length. The MO signal is split to feed multiple isolated outputs

including the timing system clock, beam diagnostics clocks, and the storage ring and injector RF systems. The MO is located in the storage ring RF hall and must be transmitted ~200m to the injector building. To minimize thermal phase drifts, two 7/8 phase stabilized coaxial lines are used between the SR RF and Injector RF buildings. The MO signal is sent down one line, split with one leg returning on the return line to a phase lock loop (PLL) that corrects for half the round trip error to stabilize the injector signal. Since the identical cables see the same thermal gradients, the PLL will improve the phase error. The MO signal in the Ring and Injector RF systems is then used to generate the 550 MHz local oscillator (LO) for up/down conversion from the RF ring and linac frequencies to the 50 MHz intermediate frequency (IF) for signal processing. The 80 MHz DAC clock is also generated directly from the MO and sent to the cavity field controller

Digital Cavity Field Controller

A common hardware platform [2] has been developed for the cavity field controllers for both the booster and storage ring systems and eventually for the linac. The field controller consists of six 500 MHz RF input channels which are down-converted to 50 MHz, digitized by ADC's clocked at $80\text{MHz}/2$. The digital signal processing is performed with a high density FPGA which computes the required output which that is sent to the DAC's for conversion to 50 MHz IF and up-converted to 500 MHz to drive the amplifier cavity chain. The turn-key linac will be commissioned with vendor-supplied equipment and will then be replaced with the NSLS-II field controller. The functional diagram is shown in Figure 1.

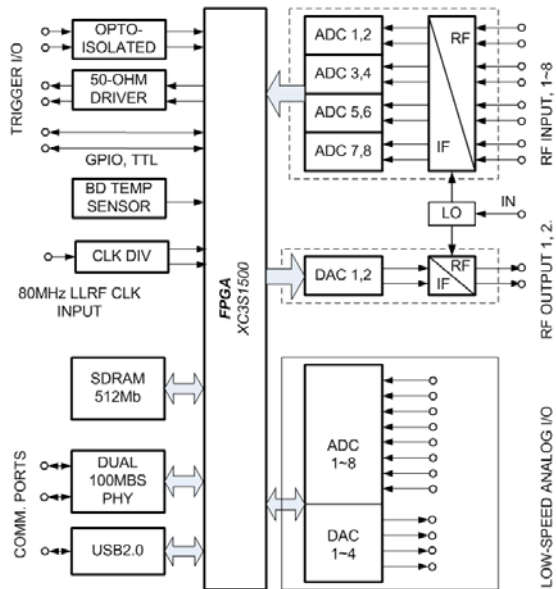

Figure 1. Functional diagram of the field controller module.

INJECTOR RF SYSTEMS

Linac

The linac bunching system consists of a 500 MHz modulated planar triode gun capable of bunch trains from 1 to 150 bunches of ~1ns length. The gun is followed by a 500 MHz subharmonic buncher and 2998MHz prebuncher that compresses the bunches to fit within single 2998 MHz linac buckets. The beam is then accelerated to 3 MeV with a 2998MHz final buncher and to 200 MeV with four 5.2 meter TW accelerating sections. The final buncher and accelerating sections are powered by two 42 MW klystrons, one feeding the final buncher and first two TW sections and the second klystron feeding the third and fourth TW sections. A third klystron “hot spare” can be switched into either position. The klystrons are powered by solid state modulators using IGBT switches at 1.2 kV feeding a split core, multi-turn primary pulse transformer [3]

Booster RF

The booster synchrotron has a single PETRA 7-cell cavity [4] located in one of four straight sections. The 7 7-cell cavity was chosen over the 5 5-cell for its higher shunt impedance, which allows the 1.2 MV accelerating voltage to be obtained with an overall cavity and beam power that fits well within the 80 kW of conventional broadcast Inductive Output Tubes (IOT).

The transmitter is a L3 80 kW IOT with a Pulse Step Modulated (PSM) HV power supply.

STORAGE RING SYSTEMS

500 MHz Fundamental RF System

The NSLS-II storage ring has two 9m 9m-long straight sections dedicated for RF. They are separated by a short low beta straight optimized for insertion device use. Each of the RF straights will consist of two 500 MHz fundamental cavities and one passive 1500 MHz bunch lengthening cavity.

The requirements of the fundamental RF system varies with the beam current and synchrotron energy loss per turn, both of which will increase from commissioning of the machine to the fully built out complement of insertion device beamlines in the future. To accommodate this variation of beam power and hence RF power required over the project lifetime, the RF cavity installation is done in two phases. In the initial project phase, only one RF straight will be populated with two 500MHz and one 2-cell 1500MHz cavity.

The Cornell CESR-B cavity has been chosen for the first two fundamental cavities. It is a proven design utilized by several existing light sources. One difference for the NSLS-II machine is the very high power coupling required due to the small ratio of cavity power to beam power

As designed by Cornell [5], the CESR-B has a Q-external of ~200,000. For NSLS-II the maximum beam-power required per cavity is 270kW, and the voltage/cavity only 1.25MV, corresponding to a cavity dissipation of ~18 watts. The coupling β is given by

$$\beta = 1 + \frac{P_{beam}}{P_{cavity}} \quad \text{and} \quad Q_{ext} \approx \frac{Q_0}{1 + \beta}.$$

This corresponds to a $\beta = 15000$ and an external Q = 65,000. We have redesigned [6] the waveguide aperture coupling to the cavity by enlarging the aperture and increasing the length and width of the coupling tongue to achieve the required Q external. Figure 2 shows the geometry and the field plots from HFSS.

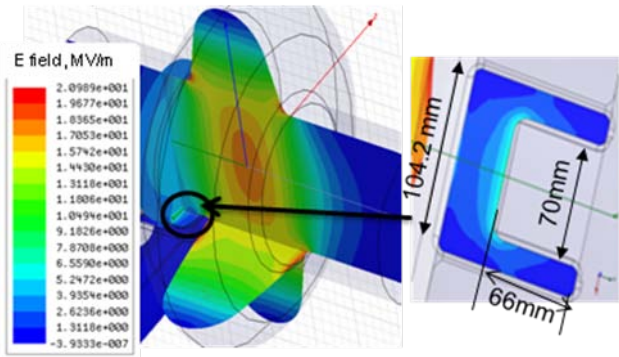

Figure 2 2. HFSS plot of the electric field intensity in the waveguide to beam pipe coupling aperture. Fields are normalized to 2.4 MV accelerating voltage.

Storage Ring Transmitter

The transmitter consists of a 300kW klystron with a pulse step modulated cathode power supply. Studies at the Canadian Light Source (CLS) using the NSLS-II cavity controller on a klystron amplifier identical to that proposed for NSLS-II identified switching sub-harmonics superimposed on the RF fields. The switching frequency is ~ 100 kHz, well out of band. However, there are 86 switching modules and frequency lines of $100\text{kHz}/86 \sim 1.16\text{kHz}$ spacing are present from the carrier to beyond a 100kHz offset. Since these may overlay the NSLS-II frequency synchrotron frequency of between 3 and 4, they have been further suppressed by improving the output filters on the switching modules for these frequency harmonics. The switching frequency may be slightly altered as well, in the unlikely event a subharmonic lies directly on the synchrotron side band.

Third Harmonic Bunch Lengthening Cavity

In order to increase the Touschek scattering dominated beam lifetime, a third harmonic cavity is used to lengthen the bunches. Approximately $1/3$ the fundamental voltage is required for optimal bunch lengthening. Since the fundamental voltage is ~ 3 MV for the initial project (one RF straight) and 5 MV for the full RF system, the harmonic cavity must provide approximately 1 MV per RF straight. Wishing to limit the gradient in the SRF cavities to less than six to eight MV/m we require at least two cavities in one of the RF straights. The need to include two 500MHz cavities and two 1500 MHz cavities in the 8m RF straight led to the necessity of including the two 1500MHz cavities in a common cryostat. Of course we could have elected to redesign the 500MHz cavities to a common cryostat, but this was considered too risky.

It was decided to use the innovative but unproven concept of using a coupled two-cell cavity for passive operation in a high current storage ring [7]. Since there are N modes in an N-cell coupled system, the difficulty is in the control of the second mode for the coupled two-cell cavities. To first order the mode separation of the zero and pi modes is a function only of the cell-to-cell coupling. By careful cavity design and independent tuning of the zero and Pi mode in the cavities, we have been able to tune the desired π -mode from minimum to design (1MV) excitation while keeping the unwanted zero mode safely between beam revolution lines without excitation. The two-cell cavity is shown in Figure 3.



Figure 3. 1500 MHz two two-cell niobium cavities with SS helium vessel end spoils.

Cryogenic system

The SRF systems require a liquid helium refrigerator system as well as a liquid nitrogen delivery system. Both of these systems can impact the performance of the RF system through microphonics, thermal and thermo-acoustical oscillations in the LHe pressure. These act directly on the niobium cavities and can detune the cavity by changing the geometry. The LHe system is designed to regulate the SRF cavity helium vessel pressure to ± 0.2 kPa. The LN2 system is not directly cooling the cavity,

but cools the thermal transitions and provides a 77K thermal radiation shield. However, fluctuations in the nitrogen pressure cause temperature changes, and the temperature variations of the thermal transition change the length of the beam pipe thermal transitions tuning that tune the cavity frequency.

INITIAL TEST RESULTS

In order to demonstrate the performance of the system, the digital cavity field controller was taken to the Canadian Light Source [7] and tested on the CESR-B cavity and PSM-powered klystron transmitter nearly identical to those being built for NSLS-II. The cavity field amplitude jitter was measured to be 0.026% rms and the phase jitter was 0.019 degrees rms, both well within the specified values. The harmonic cavity has been tested at 4.2 K and we have verified the tuning of the 0 and π -modes over a 1MHz range, which is sufficient to meet the bunch lengthening, shortening, and parked operational modes. The cavity was RF conditioned up to 400 kV, which was the limit of the 30 watt amplifier. The Q loaded was measured to be $5 \cdot 10^7$ after this minimal RF conditioning.

SUMMARY

The NSLS-II RF systems design is complete and fabrication of the subsystems is in progress. Installation of

the storage ring transmitters will begin in August of 2011, and linac installation in September of 2011. Cryogenic systems will be installed in late 2012.

REFERENCES

- [1] W. Guo et al., "Longitudinal Beam Parameter Tolerances of NSLS-II," PAC 2007
- [2] H. Ma, "The Low-Level Radio Frequency System for Superconducting Cavities of the National Synchrotron Light Source II," PAC 2011
- [3] W. Crewson et al, "Green Pulsed Power Achieved by Efficient Solid State Pulsed Power Technology", Pulsed Power Conference, Hawaii, 2010
- [4] H. Gerke et al., "Das Petra Cavity," DESY note PET-77/08, 1977
- [5] H. Padamsee et al., "Accelerating Cavity Development for the Cornell B-Factor, CESR-B," PAC 1991
- [6] M. Yedulla et al., "Design of the Coupler for the NSLS-II Superconducting Cavity," PAC 2011
- [7] J. Rose et al., "Design and Preliminary Test of the 1500 MHz NSLS-II Passive Superconducting Cavity," PAC 2011
- [8] L. Dallin et al., "The Canadian Light Source," PAC 2003