



BNL-94128-2011-CP

***The fundamental power coupler and pick-up of the
56 MHz cavity for RHIC***

Q. Wu, S. Bellavia, I. Ben-Zvi, C. Pai

*Presented at the 2011 Particle Accelerator Conference (PAC'11)
New York, N.Y.
March 28 – April 1, 2011*

Collider-Accelerator Department

Brookhaven National Laboratory

**U.S. Department of Energy
Office of Science**

Notice: This manuscript has been authored by employees of Brookhaven Science Associates, LLC under Contract No. DE-AC02-98CH10886 with the U.S. Department of Energy. The publisher by accepting the manuscript for publication acknowledges that the United States Government retains a non-exclusive, paid-up, irrevocable, world-wide license to publish or reproduce the published form of this manuscript, or allow others to do so, for United States Government purposes.

This preprint is intended for publication in a journal or proceedings. Since changes may be made before publication, it may not be cited or reproduced without the author's permission.

DISCLAIMER

This report was prepared as an account of work sponsored by an agency of the United States Government. Neither the United States Government nor any agency thereof, nor any of their employees, nor any of their contractors, subcontractors, or their employees, makes any warranty, express or implied, or assumes any legal liability or responsibility for the accuracy, completeness, or any third party's use or the results of such use of any information, apparatus, product, or process disclosed, or represents that its use would not infringe privately owned rights. Reference herein to any specific commercial product, process, or service by trade name, trademark, manufacturer, or otherwise, does not necessarily constitute or imply its endorsement, recommendation, or favoring by the United States Government or any agency thereof or its contractors or subcontractors. The views and opinions of authors expressed herein do not necessarily state or reflect those of the United States Government or any agency thereof.

THE FUNDAMENTAL POWER COUPLER AND PICK-UP OF THE 56MHZ CAVITY FOR RHIC *

Q. Wu†, S. Bellavia, I. Ben-Zvi, C. Pai

Collider Accelerator Department, Brookhaven National Laboratory, Upton, NY 11973

Abstract

A fundamental power coupler (FPC) is designed to provide fast tuning the 56MHz SRF cavity in RHIC. The FPC will be inserted from one of the chemical cleaning ports at the rear end of the cavity with magnetic coupling to the RF field. The size and the location of the FPC are decided based on the required operational external Q of the cavity. The cavity is beam driven, and the FPC is designed with variable coupling that would cover a range of power levels. It is thermally isolated from the base temperature of the cavity, which is 4.2K. A 1kW power amplifier will be used to close an amplitude control feedback loop. In this paper, we discuss the coupling factor of the FPC with the chosen design.

INTRODUCTION

The 56MHz SRF cavity is a passive quarter-wave resonator which is designed to increase the collision luminosity of the RHIC accelerator [1]. The Fundamental Power Coupler (FPC) for this beam-driven cavity is designed as a fast tuner to stabilize the amplitude at an optimized value when the cavity's resonant frequency changes. Together with the Pick-Up (PU), the feedback loop also contains a 1kW power amplifier and electronic controls. The FPC frequency tuning is a fast response supplementary to the tuning plate, which the response time is limited to the mechanical movement of the piezo materials.

Both the FPC and the PU will be located at the end of the cavity which is opposite of the accelerating gap, and are inserted through the chemical cleaning ports to avoid extra modification to the cavity itself. Figure 1 shows the location of the FPC and the PU respective to the cavity.

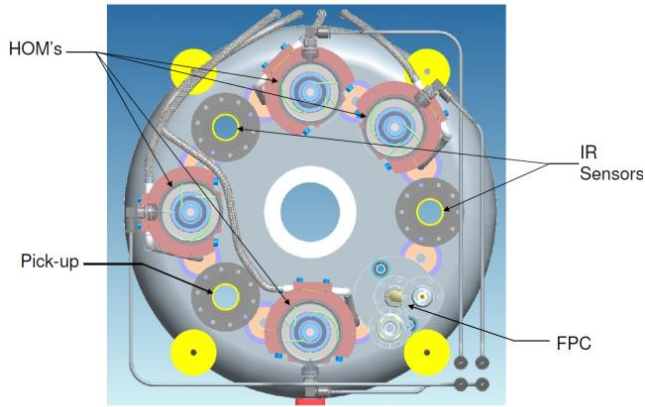

Figure 1: Location of each insertion components at the

*Work supported by Brookhaven Science Associates, LLC under Contract No. DE-AC02-98CH10886 with the U.S. DOE.
†qiuwu@bnl.gov

chemical cleaning ports.

Due to the fact that the chemical port is located at the maximum magnetic field region with barely any electric field, the FPC and the PU are loop-shaped for inductive coupling.

THEORETICAL CALCULATION

The coupling factors for both the FPC and the PU are critical for frequency tuning. With a given amplifier power, the FPC location should be optimized for maximizing the tuning ability. As of the PU, the power coupling out of the cavity should be limited for the safety of the following feedback circuit. The calculation based on an equivalent circuit is shown below to obtain the external Q of both components.

FPC

Figure 2 shows the equivalent circuit of the scenario of the FPC drives the cavity along with the beam in presence.

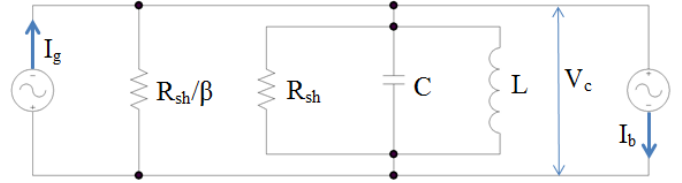

Figure 2: Equivalent circuit of FPC in the cavity.

In Figure 2, I_b is the beam current, and I_g is the generator current. L , C and R_{sh} are the cavity's RLC equivalent parameters. β is the coupling factor of the FPC.

The admittance of the system is

$$\tilde{Y}_L = \frac{\beta + 1}{R_{sh}} + \frac{2j\delta}{R_{sh}/Q_0}$$

where $\delta = 2 \frac{\omega - \omega_0}{\omega_0}$. The voltage on the cavity is then contributed from both the generator current and beam current

$$\tilde{V}_c \tilde{Y}_L = \tilde{V}_c \left(\frac{\beta + 1}{R_{sh}} + \frac{2j\delta}{R_{sh}/Q_0} \right) = \tilde{I}_g - \tilde{I}_b$$

Since we operate well off resonance, with the cavity below the beam frequency (for stability against the Robinson instability), the phase difference between the beam current I_b and the cavity voltage is

$$\varphi = -\frac{\pi}{2}$$

If we take the cavity voltage vector to be the real axis, then the generator current can be expressed as

$$\tilde{I}_g = I_{gr} + jI_{gi} = V_c \left(\frac{\beta + 1}{R_{sh}} + \frac{2j\delta}{R_{sh}/Q_0} \right) - jI_b \quad (1)$$

where the subscripts (r) and (i) correspond to the real and imaginary components.

Therefore

$$I_{gr} = \frac{(\beta + 1)V_c}{R_{sh}} \quad (2)$$

$$I_{gi} = \frac{2\delta V_c}{R_{sh}/Q_0} - I_b \quad (3)$$

For a given generator power P_g , the amplitude of the generator current I_g is

$$|I_g| = \sqrt{\frac{8\beta P_g}{R_{sh}}} \quad (4)$$

To obtain the most efficient tuning of the cavity, we need to maximize I_{gi} by optimizing the coupling factor β . Substituting Eqn. (4) to Eqn. (1), the amplitude of the imaginary part of the generator current is then

$$I_{gi}^2 = I_g^2 - I_{gr}^2 = \frac{8\beta P_g}{R_{sh}} - \frac{(\beta + 1)^2 V_c^2}{R_{sh}^2}$$

The I_{gi} maximizes at $\beta_{opt} = \frac{4P_g R_{sh}}{V_c^2} - 1$ with the value of

$$I_{gi} = \frac{4P_g}{V_c} \sqrt{\frac{\beta_{opt} - 1}{\beta_{opt} + 1}}$$

For 56MHz cavity, we have the parameters as shown in the table below.

Table 1: Parameters for 56MHz cavity

Parameter	Unit	Value
Q0		2×10^9
$\frac{R_{sh}}{Q_0}$	Ohm	40
Gap Voltage	MV	2
Amplifier Power	kW	1

The optimum coupling factor β_{opt} is 79. The corresponding external Q for the FPC is 2.5×10^7 .

With $\beta \gg 1$, I_{gi} is simplified to

$$I_{gi} \approx \frac{4P_g}{V_c} \quad (5)$$

We can then obtain the maximum tuning range of the FPC with 1kW amplifier.

The detuning of the cavity δ consists of two components, contributed from the beam and the generator respectively. We assume the contribution from the generator is a small perturbation of the frequency. This compensation results in an amplitude change of gap voltage, which is then used as the real time correction of the gap voltage. From Eqn. (3) we have

$$I_b = \frac{V\delta_0}{R_{sh}/Q_0} \quad (6)$$

$$I_{gi} = \frac{V\xi}{R_{sh}/Q_0}$$

From Eqn. (5) and (6), we can obtain the detuning due to the generator current ξ as a function of the cavity parameters

$$\xi = \frac{4P_g R_{sh}/Q_0}{V_c^2}$$

It is important to notice that under the optimum detuning setup, the detuning ability of the FPC is solely dependent on the cavity characteristics, i.e. the beam does not affect the FPC detuning.

With the parameters in Table 1, the tuning ability of the 1kW amplifier ξ at optimum working point is 4×10^{-8} , and the corresponding tuning range Δf is 1.13Hz.

PU

The power from the PU will only be used to feed in the feedback loop of the frequency tuning control, therefore 1W is sufficient for the purpose and should be safe for the LLRF circuit.

The calculation for the PU follows the same method as shown in the FPC section. With 1W of power, the coupling factor should be 0.08, and the corresponding external Q is 2.5×10^{10} .

SIMULATION

With the result from the theoretical calculation, 3D simulations are carried out via MicroWave Studio [2] to set the location of the FPC and PU loops with respect to the cavity.

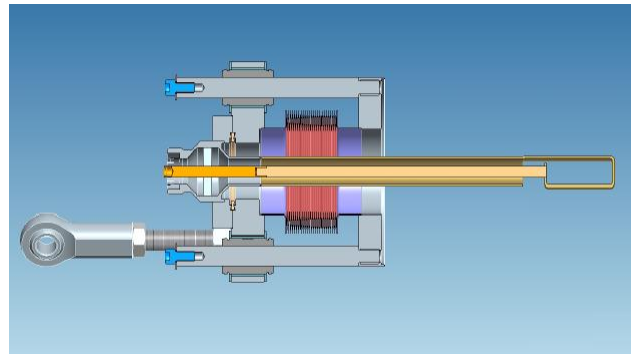

Figure 3: 3D model of the FPC setup with adjustment elements.

The current design of the FPC is shown in Figure 3. The adjustment of the loop location is made feasible by mechanical step motor. The motion resolution can be as small as micron range. For simplicity, the PU will use the same design. The motion system will be used for initial set up of the components. Once the cavity start operating, real time tuning of the frequency is achieved by the feedback circuit and driving amplifier. Table 2 lists the design parameters of the FPC.

Table 2: Geometry of the FPC.

Parameter	Value [cm]
loop length	3
loop height	1.6
loop width	1.1

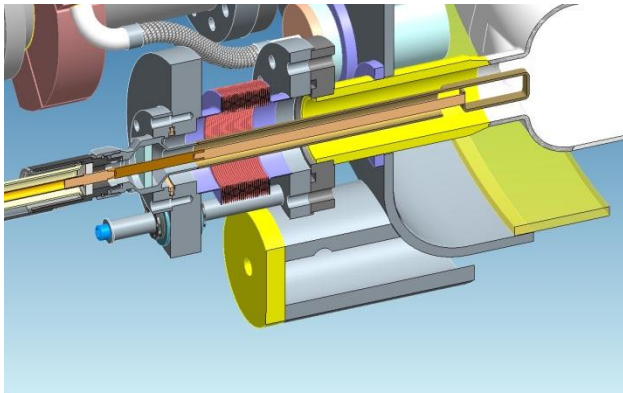

Figure 4: Installed FPC with respect to the cavity.

Figure 4 shows the 3D view of the installed FPC. Matching windows are carefully designed to prevent RF reflection.

The simulation is done with MWS under 50Ω port matching scheme. Length D is defined as the distance between the start point of the inner conductor of the FPC and the end of the cavity, as shown in Figure 5.

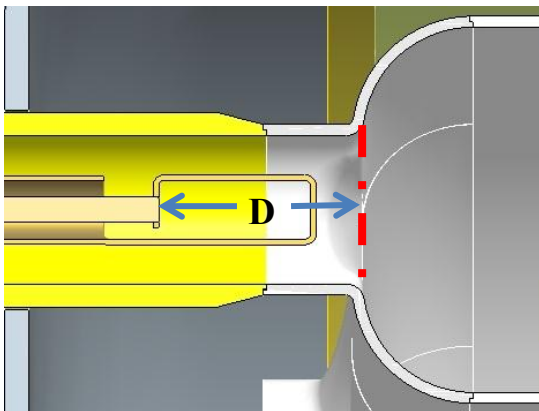

Figure 5: Close up view of the FPC installation in the cavity.

The external Q of the FPC port increases as the FPC loop retracts out from the cavity, i.e. the D increases. From the simulation result shown in Figure 6, to satisfy the optimum tuning, the FPC is retracted 4cm from position which the loop is fully inside the cavity, i.e. $D = 4cm$.

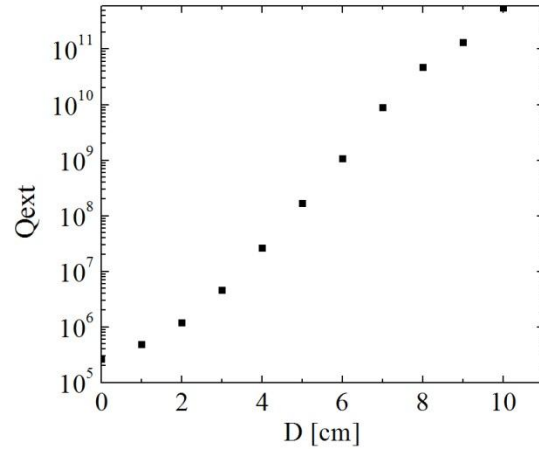

Figure 6: External Q of the FPC port versus the change in FPC location.

The field in between the outer conductor of the FPC and the chemical cleaning tube wall is less than 10 gauss, and even less for the PU. Thus the flange area should not be heat up and saved cooling efforts.

The PU shares the same design as of the FPC, therefore, from Figure 6 we can also conclude the location of the PU is $D = 7.8cm$.

CONCLUSION

The FPC and the PU of the 56MHz SRF cavity for RHIC can share the same design with different locations in the cavity. With 2MV gap voltage, the optimum tuning range for the current FPC design is 1.13Hz.

REFERENCES

- [1] I. Ben-Zvi, *Superconducting Storage Cavity for RHIC*, Tech. Rep. 337 (Brookhaven National Laboratory, Upton, NY 11973 USA, 2004).
- [2] CST Microwave Studio Suite 2010.