

TEST OF A COAXIAL BLADE TUNER AT HTS/FNAL

Y. Pischalnikov#, S.Barbanotti, E.Harms, A.Hocker, T. Khabiboulline, W. Schappert
 FNAL, Batavia, IL 60510, USA
 A.Bosotti, C.Pagani, R.Paparella
 INFN/LASA, Milano, Italy

Abstract

A coaxial blade tuner [1] has been selected for the 1.3GHz SRF cavities of the Fermilab SRF Accelerator Test Facility [2]. Results from tuner cold tests in the Fermilab Horizontal Test Stand [3] are presented.

INTRODUCTION

Fermilab is constructing the SRF Accelerator Test Facility [2], a facility for accelerator physics research and development. This facility will contain a total of six cryomodules, each containing eight 1.3 GHz nine-cell elliptical cavities. Each cavity will be equipped with a Slim Blade Tuner [1] designed by INFN Milan.

The blade tuner incorporates both a stepper motor and piezo actuators to allow for both slow and fast cavity tuning. The stepper motor allows the cavity frequency to be statically tuned over a range of 500 kHz with an accuracy of several Hz. The piezos provide up to 2 kHz of dynamic tuning for compensation of Lorentz force detuning and variations in the He bath pressure.

The first eight blade tuners were built at INFN Milan, but the remainder are being manufactured commercially following the INFN design. To date, more than 40 of the commercial tuners have been delivered.

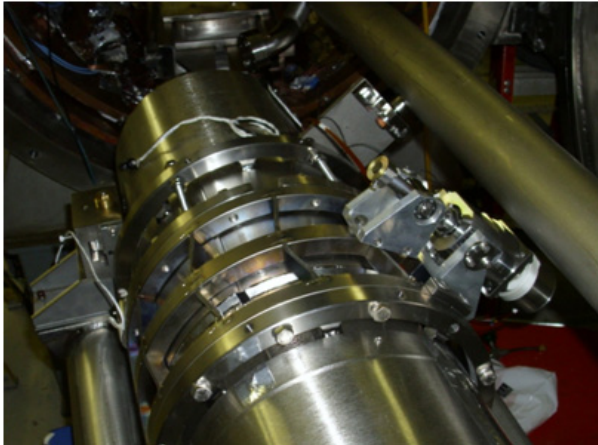

Figure 1: Blade Tuner Equipped CM2 Cavity Prior to HTS Testing

CM2 Piezo Capsules

Piezo actuators can be damaged if they are subject to excessive shear forces. To limit shear, each actuator for the CM2 cavities was encased in a stainless steel capsule

*This manuscript has been authorized by Fermi Research Alliance, LLC under Contract N. DE-AC02-07CH11359 with U.S. Department of Energy.
 #pischaln@fnal.gov

as shown in Figure 2.

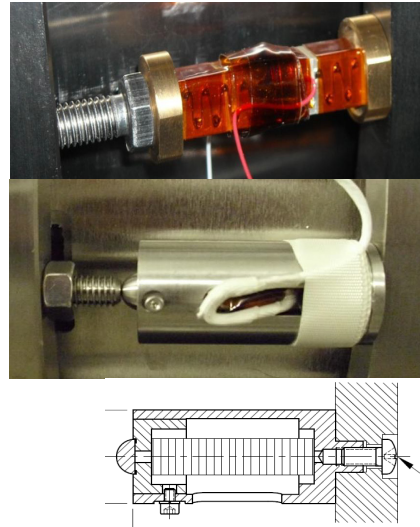

Figure 2: Un-encapsulated and encapsulated piezo actuators

TUNER TESTING IN THE HTS

Following installation of the tuner on each dressed cavity, the assembly is cold tested in the Fermilab Horizontal Test Stand (HTS) to ensure it meets CM2 performance requirements [4].

A dedicated HTS Tuning Control System has been developed to allow the performance of each tuner to be characterized and to provide compensation for Lorentz force detuning during other HTS operations. The compensation system can track changes in the cavity resonant frequency as operating conditions (e.g. gradient, pressure, etc.) change and can adapt the piezo drive waveform to keep the cavity on resonance.

Those steps of the overall HTS test procedures related to the tuner performance evaluation are listed in Table 1.

To date a total of 10 CM2 cavities have undergone testing in the HTS.

Table 1: Tuner Related Test Procedures

1.	The room temperature cavity resonant frequency is measured prior to cool-down using a network analyzer.
2.	The cavity is cooled to its operating temperature of 2K and the resonant frequency is again measured using a network analyzer.
3.	The tuner stepper motor is exercised to ensure that the cavity can be set to any frequency within the

	required slow tuning band.
4.	The cavity is tuned to the nominal operating frequency of 1.3GHz using the stepper motor.
5.	The cavity is connected to the pulsed RF system and the maximum operating gradient is established following coupler conditioning.
6.	The cavity gradient is set to 5 MV/m and the piezo actuators are exercised to ensure the cavity can be set to any frequency within the required fast tuning band.
7.	The gradient is increased in 5 MV/m steps up to the maximum gradient and the piezo actuators are exercised at each step.
8.	The gradient of the cavity is set several MV/m below the maximum gradient and the piezo actuators are driven with short pulse 10 ms prior to the arrival of the RF pulse. The piezo-RF delay for the next pulse is shortened to 9.5 ms and this process is repeated until the piezo pulse arrives 10 ms following the RF pulse.
9.	The results of the previous delay scan are used to calculate the piezo waveform needed to compensate for Lorentz force detuning and the fast tuning compensation system is turned on.
10.	The cavity gradient is increased while the piezo compensation system remains active and the level of residual Lorentz force detuning during the RF flatop at maximum gradient is recorded

SLOW TUNER PERFORMANCE

Figure 3 shows the frequency of one cavity, AES009, as the stepper motor is exercised. The response of the cavity frequency is linear to within several % as the stepper motor is rotated.

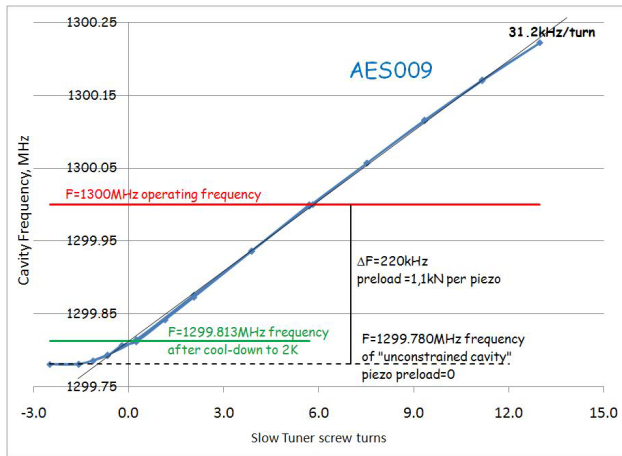

Figure 3: Cavity frequency as a function of tuning motor steps. One turn of the slow tuner screw is equivalent to 17600 steps of the stepper motor.

Table 2 provides a summary of the measured slow tuner performance parameters for all cavities tested to date.

The slow tuner tests also provide useful information about the piezo actuator preload. Piezo actuators can lose stroke if they are subject to forces higher than their specified blocking force, but can be damaged if they are operated with no load. The blade tuner is designed to maintain a preload of between 25% and 75% of the 4 kN blocking force for the actuators.

Table 2: Summary of Cavity/Tuner measured performance parameters

Cavity ID #	Frequency before tuner installation (MHz) 1bar, 300K	Frequency after cool-down (MHz) He -23torr, 2K	Slow Tuner slope (kHz/turn)	Piezo-to-Cavity Sensitivity, Hz/V	Dynamic LFD Hz/s/(MV/m) ²
ACC013	1297.385	1299.900	26.5	7.2	-970
AES009	1297.388	1299.813	31.2	2.7	-1240
ACCEL8	1297.321	1299.750	-	6.5	-860
AES010	1297.200	1299.793	27.9	8.5	-950
AES008	1297.175	1299.735	26.5	7.3	-1600
ACC016	1297.415	1299.899	28.1	10.5	-880
RI029	1297.106	1299.757	-	14	-650
AES007	1297.338	1299.791	26.3	10.4	-740
RI018	1297.417	1299.882	27.9	13	-740
Average	1297.336	1299.813	27.8	9.7	-960
σ	0.116	0.065	1.7	2.8	295

As the AES009 stepper motor is driven below the nominal zero point, the cavity frequency approaches a “knee” at 1299.780MHz. At the knee, the blades no longer exert any force on the cavity. The frequency of the knee allows the piezo preload at the cavity operating frequency to be estimated. The AES009 preload of 1.1kN per piezo is within the acceptable range.

FAST TUNER PERFORMANCE

The piezo bias scans described in steps 5 through 7 of Table 1 measure

- The static sensitivity of the cavity frequency to the piezo drive voltage;
- Piezo hysteresis;
- The dynamic sensitivity of the cavity to the Lorentz force.

Figure 4 compares cavity detuning throughout the course of the RF pulse at two gradients as the piezo drive voltage is varied. In both cases, the frequency of the cavity closely tracks the piezo bias. While the cavity frequency changes very little during the RF pulse at the

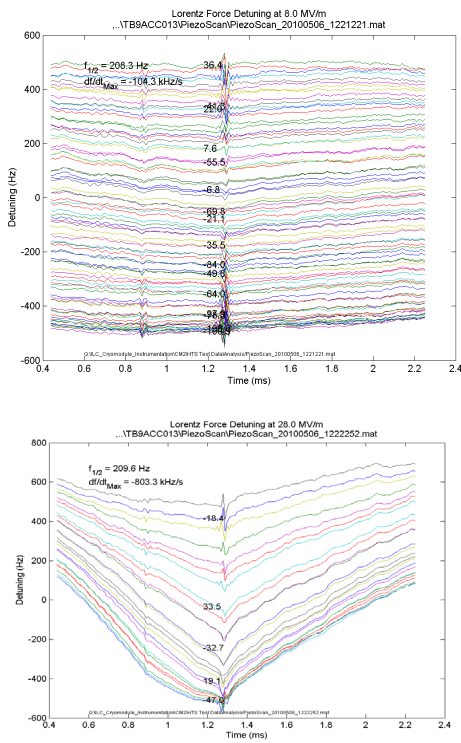

Figure 4: Cavity frequency during the RF pulse at gradients of 8 and 28 MV/m as the piezo bias is varied.

lower gradient, at the higher gradient the effects of the Lorentz force are clearly visible.

Figure 5 shows the hysteresis in the cavity frequency at a low gradient as the piezo bias is raised from 0V to 200V and then lowered back to the starting point.

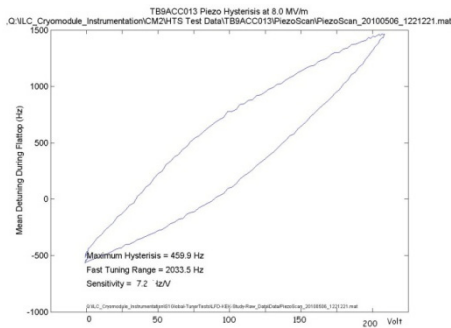

Figure 5: Piezo Hysteresis at $E_{acc}=8\text{MV/m}$.

Figure 6 shows the Lorentz force detuning of cavity ACC13 for different gradients up to the maximum of 27MV/m.

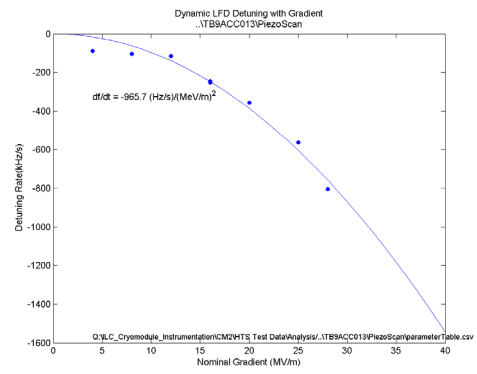

Figure 6: Lorentz Force Detuning as a Function of Gradient.

LORENTZ FORCE DETUNING COMPENSATION

The delay scan described in steps 8 and 9 of Table 1 measures the response of the cavity frequency to the Lorentz force and to the piezo actuator. Using this information, the compensation system determines the piezo drive waveform required to compensate for Lorentz force detuning [5].

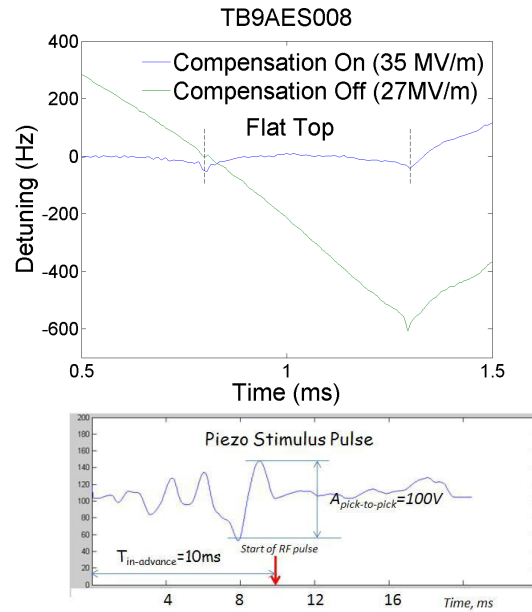

Figure 7: Lorentz Force Detuning compensation. The green and blue lines of the upper plot show the detuning of a cavity before and after compensation for Lorentz force detuning. The lower plot shows the piezo waveform.

Once the tuner performance has been characterized, the compensation system is routinely used to stabilize the cavity resonance during heat load measurements. These measurements can require several hours of stable operation at each load point [3].

CONCLUSION

Cavities for the CM2 cryomodule are subject to a battery of tests to verify that both the slow and fast tuners meet performance specifications.

REFERENCES

- [1] C.Pagani *et. al.*, "The Coaxial Tuner for ILCTA_NML at Fermilab", EPAC2008, Genoa, Italy
- [2] J. Leibfritz *et al*, "Status and Plans for a SRF Accelerator Test Facility at Fermilab", PAC2011, New York, USA
- [3] A.Hocker *et. al.*, "High power tests of dressed superconducting 1.3GHz RF cavities", PAC2011, New York, USA
- [4] C.Ginsburg *et. al.*, "1.3GHz superconducting RF cavity program at Fermilab", PAC2011, New York, USA
- [5] W.Schappert and Y.Pischalnikov, "Resonance Control in SRF cavities at FNAL" PAC2011, New York, USA