

C-A/AP/#371
January 2010

R&D ERL: Diagnostics

D. Gassner



**Collider-Accelerator Department
Brookhaven National Laboratory
Upton, NY 11973**

Notice: This document has been authorized by employees of Brookhaven Science Associates, LLC under Contract No. DE-AC02-98CH10886 with the U.S. Department of Energy. The United States Government retains a non-exclusive, paid-up, irrevocable, world-wide license to publish or reproduce the published form of this document, or allow others to do so, for United States Government purposes.

R&D ERL - Diagnostics

D. Gassner

Abstract

The Energy Recovery Linac (ERL) prototype project is currently under development at the Brookhaven National Laboratory. The ERL is expected to demonstrate energy recovery of high intensity beams with a current of up to a few hundred milliamps, while preserving the emittance of bunches with a charge of a few nanocoulombs produced by a high current SRF gun. To successfully accomplish this task the machine will include beam diagnostics that will be used for accurate characterization of the three dimensional beam phase space at the injection and recirculation energies, transverse and longitudinal beam matching, orbit alignment, beam current measurement, and machine protection. This report outlines requirements on the ERL diagnostics [1] and describes its setup and modes of operation.

Introduction

The BNL Prototype ERL [2] is an R&D effort aimed at reducing risks and costs associated with the proposed RHIC II electron cooler [3] and eRHIC collider [4]. The ERL will serve as a test bed for developing and testing instrumentation and studying physics and technological issues relevant to very high current ERL's. The prototype ERL, mated to a high current SRF gun, is expected to demonstrate production and energy recovery of high intensity, low emittance beams with a current of up to a few hundred milliamps. To successfully accomplish this task the ERL will include beam diagnostics required to characterize and tune beam parameters, as well as for machine protection. A preliminary diagnostics plan was presented in earlier publications [1, 7]. In this report, we describe the diagnostics presently planned to provide the data needed to meet these goals.

Beam Parameters and Diagnostics Requirements

Table 1 presents beam parameters of the beam after the gun and in the ERL loop for different operational modes.

Parameter	High Current	High Charge
Inj. Energy (MeV)	2-3	
Max. Energy (MeV)	16-20	
Bunch freq. (MHz)	10-351.8/703.8	10
Bunch Charge (nC)	1.4 / 0.7	5-10
Beam Current (mA)	14-500 / 500	50-100
ϵ_x/ϵ_y (μm , norm.)	2	5-10
Bunch length (ps)	40	60
dE/E (rms)	0.01	0.015

Table 1: Expected beam parameters at Prototype ERL

Parameter	Range / Expected Value	Accuracy	Resolution	Comments
Injection Line				
Beam loss (localized)	0-25 μ A / <500 nA	20%	5 nA	Beam Loss Monitors
Beam position	\pm 1.5 cm	200 μ m	50 μ m	BPMs
Beam Emittance	2-10 μ m	30%	0.2 μ m	Pepper Pot
Transverse Beam Size	2-5 mm	5%	20 μ m	Flags (OTR, YAG)
Beam Halo		20%	1 nA	Scraping
Bunch Charge	0.1-10 nC	5%	1%	1% resolution desirable
Ghost Bunches	10 nA @ 10 MHz	20%	1 nA	
Recirculation Loop				
Beam loss (localized)	0-2500 nA / <50 nA	20%	0.5 nA	Beam Loss Monitors
Beam position	\pm 1.5 cm	100 μ m	20 μ m	BPMs
Bunch RF phase		1°	0.25°	
Beam Emittance	2-10 μ m	40%	0.3 μ m	Quad Scan
Transverse Beam Size	0.1-5 mm	10%	5-20 μ m	Flags (OTR, YAG)
Bunch length (Full)	50-150 psec	10 psec	2 psec	Streak Cam, Sync laser pulses
Energy spread	1%	1e-3	2e-4	Via transverse size
Beam Current	0-500 mA	1%	0.25 μ A-1%	
Diff. Current Loss	< 1 μ A	1%	0.25 μ A	2 DCCTs, nulling feedback
Beam Halo			1e-6	
M ₅₆	\pm 20 cm / 0.0	10%	0.5 cm	Longitudinal BTF

Table 2. Accelerator Physics Beam Diagnostics Parameters

Diagnostics Quantities and Layout

Table 3: ERL Diagnostics Quantities

	Gun	Ring	Dump	Total
BPM	4	11	1	16
DCCT	1		1	2
FCT	1			1
Flag	3	5	1	9
Pepper Pot	1			1
Wire		1		1
Scraper	4			4
Synch Light		4		4
PMT BLM	3	9		12
Pin Diode BLM		8		8
Heliac BLM		4	8	12
Thermocouples			1 array	1
Thermal Camera	1		1	2

Figure 1 shows layout of diagnostics planned for the Gun/Injector. Similarly, Figure 2 shows the Ring diagnostics.

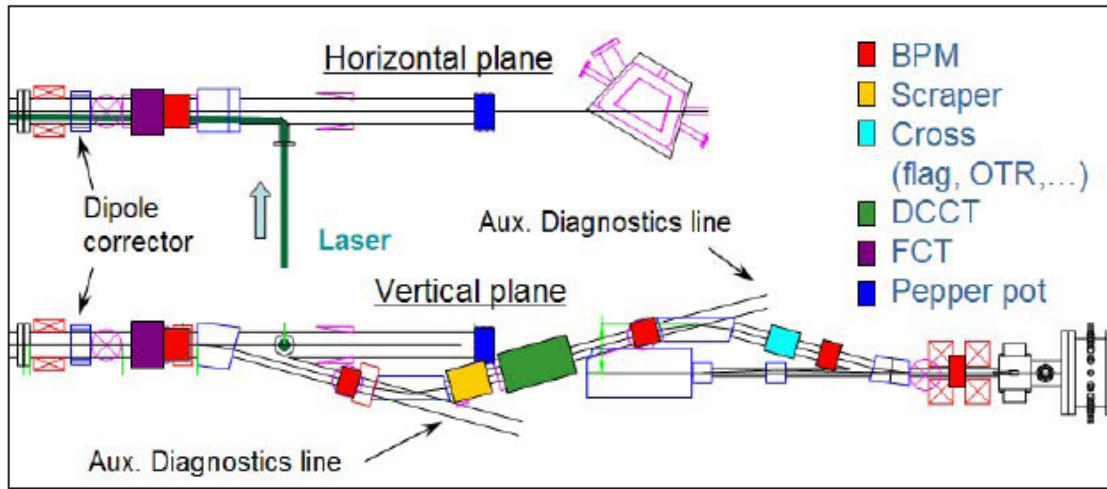

Figure 1: L ayout of ERL Injector Diagnostics.

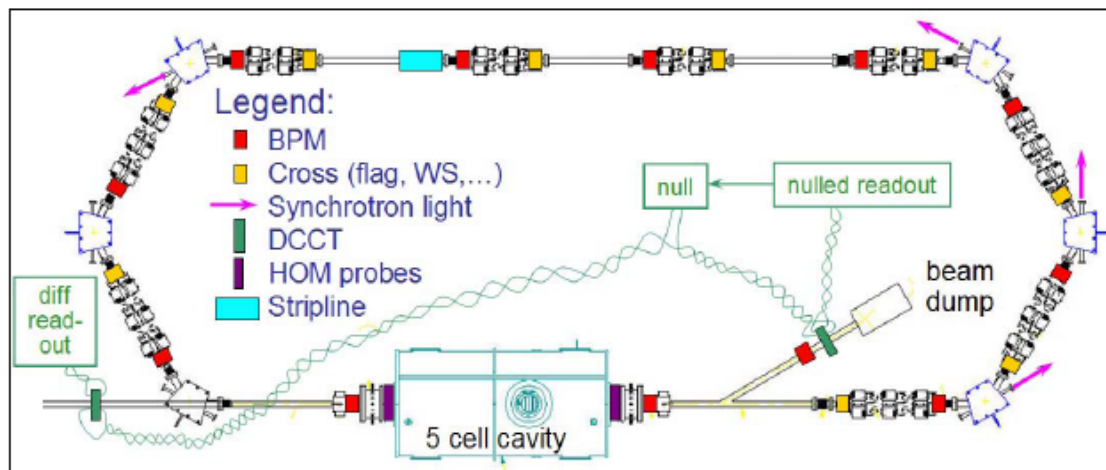

Figure 2: L ayout of ERL Recirculation Loop Diagnostics.

Beam Position Monitors

The pickups are 10mm diameter button electrodes from Times Microwave (max bake out 200C) with SMA connectors. With the exception of the injection line, they are oriented in the horizontal and vertical planes in the beam pipe. The injection line orientation is 45 degrees due to space limitations. The BPM housings are precisely machined from solid stainless steel blocks 2.5" x 2.5" x 3.25". In the ERL loop, BPM housings will be precisely positioned relative to the ring dipoles and quadrupoles.

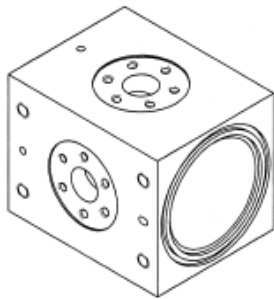

Fig. 3 BPM Mounting block
BNL Design

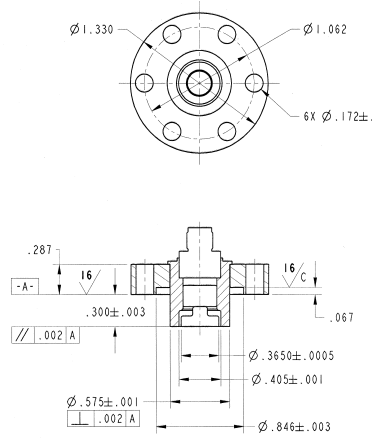

Fig. 4 BPM Button Pick-up
Times Microwave SK-59044

BPM Signal Processing:

Commercial off-the shelf Libera Brilliance [5] electronics from I-Tech is under consideration. Libera trigger modules describe here. Libera Brilliance Electronics offer high accuracy, low drift, built-in custom configurable processor, GB Ethernet, and beam inhibit capability. Beam positions can be measured from average orbit, 0.1-100mA, and single bunch, 0.1-5nC. BPM sum signals can be calibrated with this high-resolution DCCT system.

ERL Button signal simulation using Schaefer equations:

$$I_n := \frac{q \cdot N}{\sqrt{2 \cdot \pi \cdot \sigma}} \cdot e^{-\frac{(t_n)^2}{2 \cdot \sigma^2}} \quad V_{nn} := \frac{q \cdot N}{(2 \cdot \pi)^{1.5}} \cdot \frac{A \cdot Z}{b \cdot \beta \cdot c} \cdot \frac{t_n}{\sigma^3} \cdot e^{-\frac{[(t_n)^2]}{2 \cdot \sigma^2}}$$

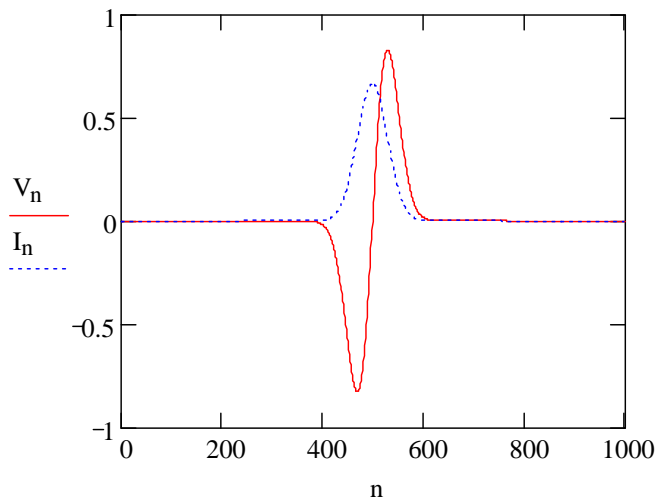

Fig 5. ERL BPM simulated voltage response to 30psec rms bunch length, 50pC bunch charge button radius 0.47cm, beam pipe radius 3cm, button capacitance 1pF.

Beam Current Monitors

Integrating Current Transformer:

Bunch-by-bunch & bunch train current will be measured by a Bergoz [6] in-flange Integrating Current Transformer ICT-CF6-60.4, 5:1 turns ratio, with rad-hard sensor option, located in the upstream injection line.

This ICT assembly has internal type E thermocouple for bake out temperature monitoring, (planned bake temperature 150C) this feature was developed by request for the ERL. Regarding effects of temperature: When the magnetic core is heated beyond 100°C, irreversible modifications occur. This does not mean one cannot exceed 100°C. The immediate consequence is a loss of magnetic permeability. The extent of permeability loss depends on temperature: At 100°C, no loss. At 168°C, about 50% loss (irreversible). The consequence of the magnetic permeability loss is an increase of output droop. The extent of the output droop depends on the transformer's turns ratio: Assuming a 5:1 turns ratio, the droop about 6%/us. When 50% permeability is lost, droop is doubled at 12%/us. An increased droop may or may not have adverse consequence, depending on the beam profile. Output for a CW beam will be differentiated twice sooner, which does not make any practical difference. Output of a beam with pulse repetition rate <100Hz will be (strictly) unchanged: Baseline returns to zero after every pulse. Output of a beam with <100 Hz pulse repetition rate will see the zero baseline drift during the first milliseconds then stabilize [6].

Beam current signals will be processed by standard Bergoz BCM-IHR Integrate-Hold-Reset electronics feeding a beam synched triggered digitizer.

Differential DCCT:

High precision current measurements will be accomplished by two specially matched Bergoz DC Current Transformers [7], model # NPCT-S-115 (New Parametric Current transformer, 115mm ID) with option for very high resolution (<0.5uA/sqrt(Hz)) and option for radiation resistant sensor.



Fig 6. NPCT Sensor, electronics, & cable.

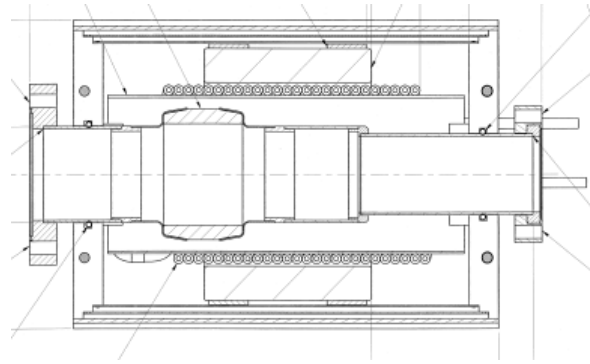

Fig 7. NPCT Sensor Assembly.

Each transformer toroid assembly will be mounted over a ceramic break, and inside a custom wall current bypass, and RF shield enclosure (see Fig 7). The maximum bake out temperature for the toroids is 80C. A water-cooled jacket is included so the adjacent and internal beam line can be baked to 200C. The water circuit does not go thru the sensor aperture. It must enter and go out on the same side of the sensor, otherwise it makes a current loop around the sensor toroid. Two layers of 0.04" mu-metal magnetic shields are integrated in the enclosure to protect the toroid from stray fields. There will be one transformer assembly installed the injection line, and one in the dump line.

The DCCT's can be also be configured in a nulling mode [7] as shown in Figure 2. Their calibration windings are joined by a single loop, powered by a low-noise current source (such as a Krohn-Hite Model 523 DC source/calibrator with +/-4ppm accuracy), driven opposite the beam. Output of dump DCCT is fed back to the current source, to drive its output to zero. The output of the gun DCCT is then a differential current measurement. Drifts (thermal, gain, magnetic field) are removed by periodic nulling without beam. The anticipated sub-microamp resolution may permit using this diagnostic as a second layer of the machine protection system in the case beam loss monitors fail to detect beam losses.

DCCT Signal Processing:

Each NPCT toroid is delivered with a 19" rack mount chassis that houses two NPCT electronics modules, and two power supply modules (see Fig 6). The spare of each type of module is provided in an adjacent non-powered slot so they are conveniently available and can be swapped quickly. Since the differential measurement is highly sensitive and will provide an input to the beam inhibit system for machine protection, the spare modules will reduce downtime in the event of failure. Remote control for gain selection test mode is available via the rear panel. Analog signals from the NPC electronics will be digitized and processed in a local front-end computer.

Profile Monitors:

Beam profile monitor stations for the G5 test facility have been designed by Radiabeam Technologies [8] will be installed in the injection region, loop transport, and dump region. Each will have multi-position pneumatic actuators with YAG and/or OTR capability. Images will be viewed from above the beam transport via an optics box that has a light labyrinth, 3-motor lens, virtual target, illumination lamp and Point Grey Flea2 [8] FireWire 1394B CCD camera. The design specification for beam profile image resolution is 50 microns.

For high sensitivity measurements of low intensity (10's of pC at 2.5MeV, and ~1pC at 20MeV) electron beams a single crystal scintillating screen shall be provided made of Cerium-doped yttrium aluminum garnet YAG:Ce.

The second screen type is a silicon wafer to be used for Optical Transition Radiation measurements of higher energy (20MeV) and higher intensity (> ~130pC) electron beams.

Mirrors – The light generated by each profile monitor screen shall be reflected towards the optical system via a 45° copper mirror mounted downstream. Since the mirror will intercept the electron beam, it can be optionally modified into Faraday Cup configuration. All mounting s will include

provisions to eliminate trapped volumes within the vacuum chamber. The electron beam power will be limited to 10W.

Impedance Matching – The profile monitor assembly will be designed so that when the screens are not in use, the vacuum chamber impedance as seen by the beam through the device will be similar to the adjacent 2" O. D. beam pipe transport. A squirrel cage configuration with slots in same direction as the beam transport for vacuum conductance will be used. The slot opening is ~5mm wide, the design goal is 75 percent open area to provide adequate vacuum conductance. The mechanical design of the squirrel cage assembly will be robust enough to support the profile monitor screens and mirror mounts.

Multi-Position Plunge - The profile monitors will be capable of pneumatically controlled plunging to three positions, each repeatable to within +/-1 mil with respect to the center of the adjacent beam pipe. The two diagnostic positions are capable of holding a variety of modules that will directly interact with the electron beam. These modules include Silicon wafer (for OTR measurements), YAG crystal (fluorescence based profile), an emittance slit module, and a target test pattern. The third position (blank) will allow full 1.874" circular diameter beam aperture as well as an impedance match described above. The order of the 3 positions shall have the impedance match squirrel cage closest to the plunger so that in the event of a pneumatic pressure failure, one of the screens will not be inadvertently inserted into the beam path. There will be normally closed position switches installed such that a remote computer can monitor each of the 3 nominal positions (fully retracted, intermediate position, and fully inserted).

Bake-Out - The profile monitors will be capable of bake-out durations of 48 hours at temperatures of 200C. Bake-out blankets will be provided by BNL.

Particulate Free – Due to the proximity of these devices to the superconducting cavities, final assemblies will be delivered and installed following class 5 clean room service per ISO 14644-1.

UHV: The vacuum components of the beam profile monitor will be fabricated and cleaned for UHV service per BNL Specification SPEC. CAD-1119. Design, joining and assembly techniques to reduce outgassing load and trapped volumes will be used for all details within the vacuum envelope.

The present ERL design will have the capability of using these assemblies in the injection region, straight sections, and dump region. In the arcs there are 6-way crosses with profile monitor measurement capability, but due to space constraints the Radiabeam station design will need to be modified if measurements are determined to be necessary at these locations.



Fig 8. Profile Monitor Assembly

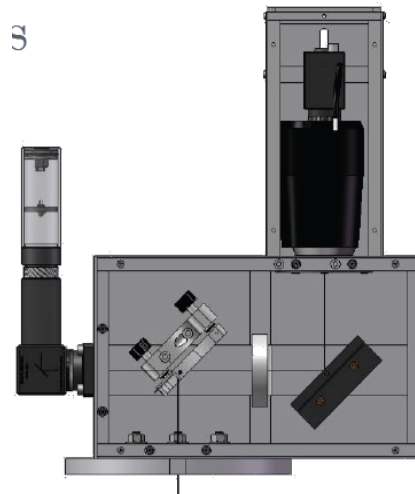

Fig 9. Optics Box Detail; Includes light labyrinth with semi-transparent mirror, 3-motor lens, CCD camera, virtual target, & illumination.

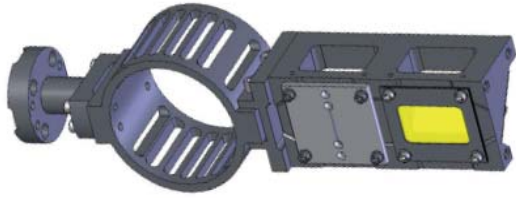

Fig 10. High Energy Plunging Assembly



Fig 11. Low Energy Plunging assembly

Image analysis: The CCD camera will be externally triggered, and images will be acquired via a personal computer running a Linux video server manager. This Linux server will transfer images via the C-AD network to the FlagProfileMonitor application for image processing and will provide beam sigma, centroid, chi-squared measurements, quality checking, as well as logging capabilities (see Fig 12).

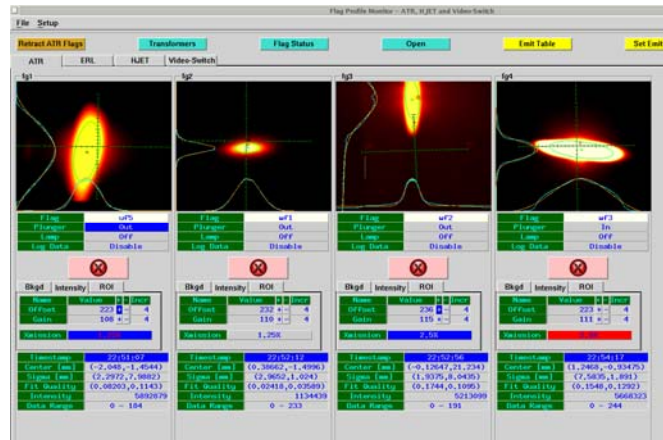

Fig 12. C-AD Frame grabber image analysis application showing beam profiles of Au beams on Gadolinium (UF5) and AlOx (WF1-3) screens, similar processing to be used at ERL for YAG & OTR screens.

Synchrotron Light – These monitors will be used to monitor the transverse beam profile in the high power/current regime. However, using these monitors can be problematic if the beam energy is below 18 MeV due to the long wavelength of the synchrotron radiation. The present plan is to have optics and CCD cameras available at the dipole chamber locations shown in Figure 2.

Beam Loss Monitors – Primary Machine Protection

Beam loss monitor detectors will be installed at locations where beam loss is considered most likely. Photomultiplier tube base BLM's, using Hamamatsu 931B, will be based on the design developed at Jefferson Lab [9]. Because of their fast response and a large dynamics range, PMT BLM's can be used for both machine tuning and protection. These detectors provide good sensitivity, self test via internal LED, <1us response, and <10us fast beam turn-off capability.

We also plan to install pin diode detectors manufactured by Bergoz [10]. Since pin diodes are sensitive to small electron losses but practically blind to X-rays, they can be used for machine tuning that might require detection of small beam losses.

The third type of BLM detectors is a Helix cable based ionization chambers [11]. These will provide calibrated, continuous coverage for the recirculation loop and in the dump region. Air-filled high frequency cables of the type Andrew HJ5-50 (diameter 22.2mm) can be mounted close to and

parallel with the beam pipe. Sensitivity is on the order of 100nA, response time <1ms, and we can expect a good linear response.

Monitoring beam losses in the injection line with BLM's can be difficult; we plan to install IR cameras to view the beam pipe temperature at the zigzag, merger region, and the dump transport.

The ERL beam transport will consist of inconel beam pipes, stainless steel BPM's and aluminum dipole chambers. Based on calculations for aluminum, the ERL Beam dipole chamber damage limit is ~ 10uA-sec (Krafft & Cameron).

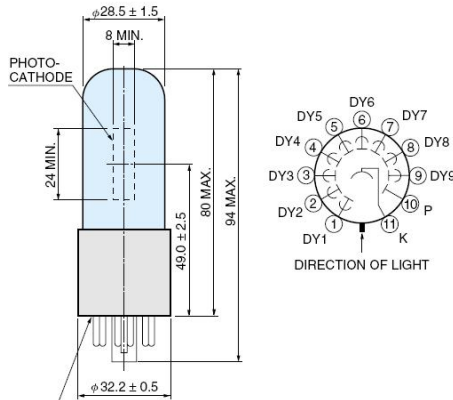

Fig. 13 Hamamatsu 931B detail



Fig. 14 PMT based BLM detector courtesy JLAB

Machine Protect Inputs:

The diagnostics systems will provide beam inhibit inputs to the machine protection system loss monitors, Differential DCCT, beam position monitors. The ERL beam transport will consist of inconel beam pipes, stainless steel BPM's and aluminum dipole chambers.

Timing, triggers and Data Time Stamping:

The planned ERL timing & triggering technique will be derived from the low level rf. These signals will be distributed throughout the facility. Each subsystem will provide its own receiver, delay, and driver electronics such as a Stanford Research Systems DG535, as needed. Unique time stamping of diagnostics data will be done using

Electron Beam Emittance will be measured at the gun extraction energy by a pepper pot located straight out of the gun. Additionally, we plan to perform a quadrupole scan at the full beam energy using a quadrupole lens and an OTR screen situated after the 5-cell cavity.

Dump Thermocouples – The temperature distribution in the beam dump will be monitored with a thermocouple array.

Halo Monitor

The Halo Monitor will be used to measure the transverse beam profiles in two dimensions (horizontal and vertical) of the 2 MeV electron beam in the injection beam transport line between the superconducting rf gun and superconducting 5-cell cavity. Eventually after the halo parameters in the injection transport are fully understood, the halo monitor may be replaced with a collimator for full power operations. Radiabeam Technologies will provide the beam line devices; their custom design parameters are based on BNL requirements. Due to the proximity of these plunging semi-destructive

devices near superconducting structures they will need to meet BNL UHV specifications SPEC.CAD-1119, & class 5 particulate level of the ISO 14644-1 before installation in the beam line.

The beam profile will be determined using the current measured from the isolated jaw (from the fully stopped portion of the intercepted electron beam) and/or from differential current monitors upstream and downstream of the Halo monitor, or via beam loss monitors. There are two existing 6-way vacuum crosses with 3.38" conflat flanges (see Figure 2) available to mount the Halo Monitor assemblies in the design of the (2.0" OD, 0.63" wall) beam line vacuum chamber. The distance from the flange face to the beam line center is 3.21".

Halo Monitor Cross 1 will have horizontal Halo Monitor plunging assemblies mounted on the beam left and beam right ports, the bottom port will be used for a vacuum pump.

Halo Monitor Cross 2 (~0.5m downstream) will have vertical Halo Monitor plunging assemblies mounted on the top and bottom ports, one of the side ports will be used for a vacuum pump.

Halo Monitor Detailed Description

Each halo monitor will have two uncooled jaws 30mm x 20 mm, material Copper. Jaw thickness will fully stop the 2MeV electron beam. Each jaw will be electrically isolated and include a UHV vacuum signal feedthrough for current measurement purposes. Each monitor axis of motion will:

- Move independently via remote stepper motor control.
- Include an integrated brake to ensure position holding without an applied voltage.
- A linear potentiometer for position readback.
- Limit switches for motion range end positions.
- Mechanical stops to prevent equipment damage.

The position of the opposing jaws in z dimension will be offset to prevent inadvertent contact. The jaw head will be demountable for cleaning. The entire assembly will be bakeable to 200C.

Both sets of scrapers are in the Injector. The scraper immediately after the gun is for primary collimation. A second scraper is located in a dispersive region for momentum collimation, and there is a possible third scraper in the Pepper Pot line.

Wire/Halo Monitor

Halo Measurement Using Scintillator/PMT's or DCCT's:

Intercepting wires will be driven through the electron beam via a precision stepping motor stage. Each plunging fork will have both a wire for beam core measurement and a block for halo measurement. The location for this device is in the loop straight section opposite from the 5-cell cavity, this is to avoid possible particulate contamination. The detailed design is in process. The only conventional diagnostic which has the sensitivity and resolution needed for halo measurement at the $\sim 10^{-6}$ level is the wire scanner. Utilizing two wires of 25 μ and 1mm diameter for the beam core and tails respectively, a dynamic range of $\sim 10^7$ has been achieved [13]. Wire scanner measurements have disadvantages. Most often they are not used in regular machine operations, but rather in a special diagnostics mode. Some portion of the machine protection system is often disabled to permit operation in the presence of the radiation resulting from scanner operation. Caution must be exercised to avoid damaging the wire due to either direct beam heating, or ohmic heating resulting from resonant modes of the wire scanner structure driven by the electromagnetic field of the beam (which also contribute to the machine impedance). Replacing damaged wires requires opening the vacuum system. In a machine with superconducting RF this is to be avoided whenever possible. Additionally, in a machine with superconducting RF there exists the possibility of surface contamination, both from damaged wires and from trapped particulates that might be freed during flexing of the welded metal bellows that are integral to such devices. Finally, high sensitivity halo measurement can be accomplished with scintillator/PMT detectors, which in the BNL ERL may be compromised by the proximity of background due to X-rays from the RF cavities.

An alternative halo measurement technique would employ the differential current system. The absolute limitation to sensitivity is flux noise in the toroids. For a machine damage threshold of 10 μ A-sec this results in a S/N of ~ 40 dB on the 1 second timescale. For the distributed loss pattern to be expected from halo, the damage threshold would likely be considerably higher. The resulting high

resolution absolute measurement of beam loss below the damage threshold would be very useful in halo tuning, as well as in verifying halo simulation code.

Possible Future Plans:

Streak Camera:

It is desirable to measure longitudinal bunch characteristics using synchrotron light or optical transition radiation. The Hamamatsu Universal Streak Camera C5680 system with temporal resolution of 2ps is under consideration.

Laser Wire Profile Monitor:

A combination of a "laser wire" with a Compton photon counter can be used to measure all three dimensions of electron bunches in the high power regime. We are evaluating a possibility of using a commercial CO₂ laser, or laser pulses of either IR or green light produced by the gun driver laser as a byproduct. Correlating the laser pulses with electron bunches we will be able to measure the longitudinal beam profile.

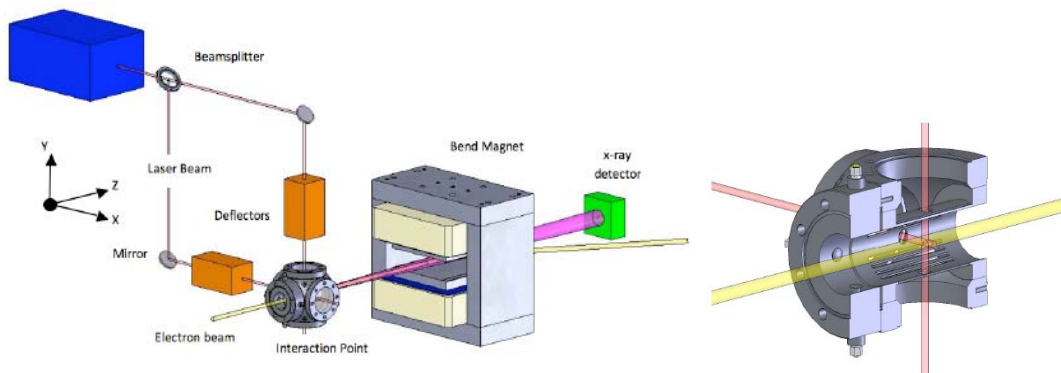

Fig 15. Laser Wire Scanner conceptual design courtesy of Radiabeam Technologies [12]

REFERENCES

- [1] E. Pozdeyev, et al, Diagnostics of BNL ERL, PAC 2007
- [2] V. Litvinenko, "Status of R&D ERL at BNL", PAC 2007.
- [3] I. Ben-Zvi, et al. Proc. of PAC 2005 (Knoxville), p. 2741.
- [4] V. Litvinenko, et al., Proc. of PAC 2005 (Knoxville), p. 2768.
- [5] Libera Brilliance website link: <http://www.i-tech.si/products.php?meni1=3>
- [6] Julien Bergoz, private communication.
- [6] Information on Bergoz current transformers is available at <http://www.bergoz.com>
- [7] P. Cameron et al, "Beam Diagnostics for the BNL ERL Test Facility" BIW 04, Knoxville.
- [8] Radiabeam Technologies website link: <http://www.radiabeam.com/>
- [8] P. Cameron, "Differential Current Measurement in the BNL ERL Test Facility", C-A/AP/203 http://www.rhichome.bnl.gov/AP/ap_notes/ap_note_203.pdf
- [9] J. Perry, et al., The CEBAF Beam Loss Sensors, PAC 1993 (Washington D.C.), p.2184.
- [10] Information on Bergoz Pin Diode detectors is available at <http://www.bergoz.com>
- [11] P. Michel, et al "Beam Loss Detection at Radiation Source ELBE"
- [12] A. Murokh of Radiabeam Technologies, SBIR Proposal "A 10MHz Pulsed Laser Wire Scanner for Longitudinal and tranverse measruements of 100mA class Electron Beams"