



**BNL-94852-2011-CP**

***NSLS-II Injection Straight Diagnostics***

*I. Pinayev, A. Blednykh, M. Ferreira, R. Fliller, B. Kosciuk,  
T. Shaftan, G. Wang*

*Presented at the 2011 Particle Accelerator Conference (PAC'11)  
New York, NY  
March 28-April 1, 2011*

March 2011

**Photon Sciences Directorate**

**Brookhaven National Laboratory**

**U.S. Department of Energy  
DOE - Office of Science**

Notice: This manuscript has been authored by employees of Brookhaven Science Associates, LLC under Contract No. DE-AC02-98CH10886 with the U.S. Department of Energy. The publisher by accepting the manuscript for publication acknowledges that the United States Government retains a non-exclusive, paid-up, irrevocable, world-wide license to publish or reproduce the published form of this manuscript, or allow others to do so, for United States Government purposes.

This preprint is intended for publication in a journal or proceedings. Since changes may be made before publication, it may not be cited or reproduced without the author's permission.

## **DISCLAIMER**

This report was prepared as an account of work sponsored by an agency of the United States Government. Neither the United States Government nor any agency thereof, nor any of their employees, nor any of their contractors, subcontractors, or their employees, makes any warranty, express or implied, or assumes any legal liability or responsibility for the accuracy, completeness, or any third party's use or the results of such use of any information, apparatus, product, or process disclosed, or represents that its use would not infringe privately owned rights. Reference herein to any specific commercial product, process, or service by trade name, trademark, manufacturer, or otherwise, does not necessarily constitute or imply its endorsement, recommendation, or favoring by the United States Government or any agency thereof or its contractors or subcontractors. The views and opinions of authors expressed herein do not necessarily state or reflect those of the United States Government or any agency thereof.

# NSLS-II INJECTION STRAIGHT DIAGNOSTICS\*

I. Pinayev<sup>#</sup>, A. Blednykh, M. Ferreira, R. Fliller, B. Kosciuk, T.V. Shaftan, G. Wang,

BNL, Upton, NY 11973, U.S.A.

## Abstract

The ultra-bright light source being developed by the NSLS-II project will utilize top-up injection and fine tuning of the injection process is mandatory. In this paper we present the diagnostics installed in the injection straight. Its use for commissioning and tuning of the injection cycle is also described.

## INTRODUCTION

The NSLS-II storage ring will utilize a 9.3 meter long injection straight section shown in Fig. 1. Injection will be

performed with two septa (one pulsed, one DC) and four kickers [1]. The stored beam will be shifted towards the pulsed septum up to 15 mm and the nominal distance between centers of the injected and the bumped beam is 9.5 mm.

The NSLS-II beam position monitors will have turn-by-turn and first-turn capabilities [2] and will be used for the commissioning and tuning the injection process. However, there are three additional BPMs and two beam intercepting OTR screens (flags) installed in the injection straight.

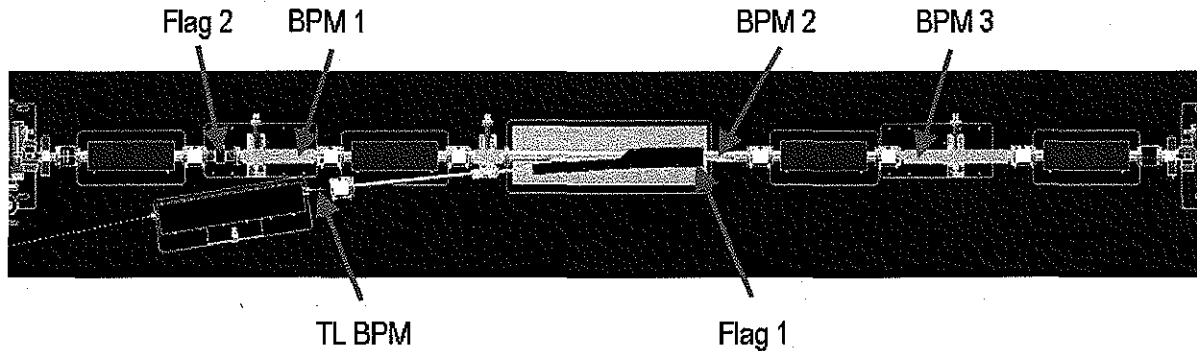

Figure 1: Layout of the injection straight.

## FLAGS

The first flag is placed at the exit of the pulsed septum and serves to view the injected beam. The OTR screen will be inserted into the slot of the septum taper (see Fig. 2). Such design provides a shield for the flag from the wake fields induced by the circulating beam and reduces impedance of the assembly. Prosilica GC1290 GigE camera will provide 17×7 mm field of view with 50 microns resolution. The distance from the screen to the camera is 0.6 meters. The final design will be done after the choice of type of the pulsed septum (in-vacuum or out of vacuum).

The second flag is inserted between the kickers 1 and 2 and serves to monitor shape and position of the injected beam after the one turn. The OTR screen will be inserted sideways into the vacuum chamber with the rectangular profile. The 19 mm diameter field of view can be extended by a scan of the screen position. The screen to the camera distance and resolution is the same.

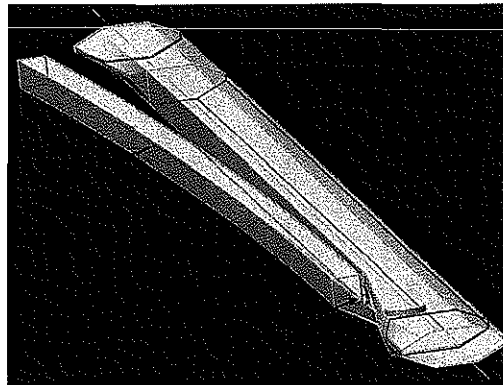

Figure 2: Vacuum chamber for the first flag.

\* This manuscript has been co-authored by employees of Brookhaven Science Associates, LLC, under Contract No. DE-AC02-98CH10886 with the U.S. Department of Energy.  
<sup>#</sup>pinayev@bnl.gov

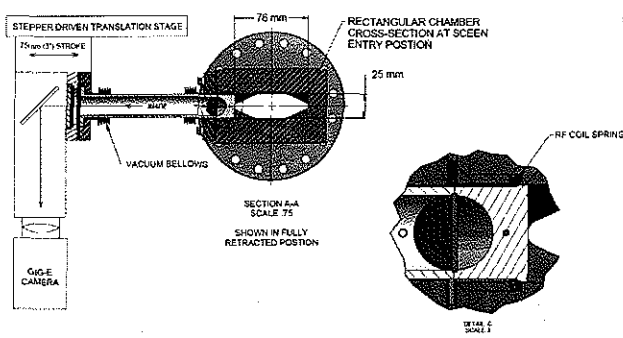

Figure 3: Vacuum chamber for the second flag.

### BEAM POSITION MONITORS

The BPMs 1 and 3 are installed on the vacuum chamber with a profile matching the multipole vacuum chambers, which have an octagonal shape. The sensitivity to the beam motion is  $S_x = 0.089 \text{ mm}^{-1}$  and is shown in Fig. 4.

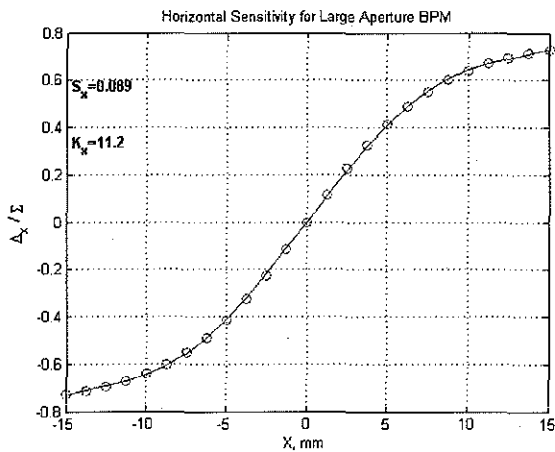

Figure 4: Sensitivity to the horizontal motion of BPMs 1 and 3. Zero position corresponds to the nominal position of the stored beam.

These BPMs will be used for monitoring of the circulating beam and calibration of the kickers. The maximum deviation of the bumped beam is approximately 9 mm, which is inside of the BPM range. A polynomial fit will be required for accurate calculation of beam position with large deviation. The accuracy of the fit can be verified by gradually increasing the kicker strength.

The injected beam enters the storage ring at nominal distance of 25 mm from the center of the vacuum chamber. Such large displacement is beyond the range of the regular BPM. Therefore, the second BPM, placed after the pulsed septum, is shifted inwards by 17.5 mm. The vacuum chamber profile is modified to accommodate

the shift and the corresponding geometry is shown in Fig. 5.

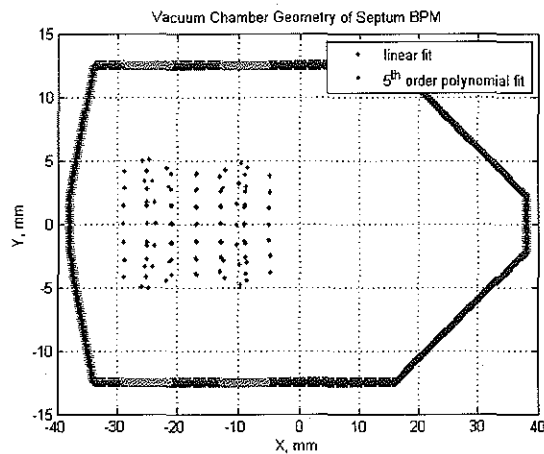

Figure 5: Geometrical profile of the second BPM placed after the pulsed septum. The vacuum is shown in magenta and buttons are shown in green. Zero position indicates the nominal position of the circulating beam. The red dots correspond to the calculated beam position with linear approximation and the blue dots correspond to the fifth order polynomial fit.

The sensitivity to the beam displacement of the second BPM is shown in Fig. 6. This BPM will be capable of measuring the position of the fully bumped beam and of the injected beam (provided there is no circulating current).

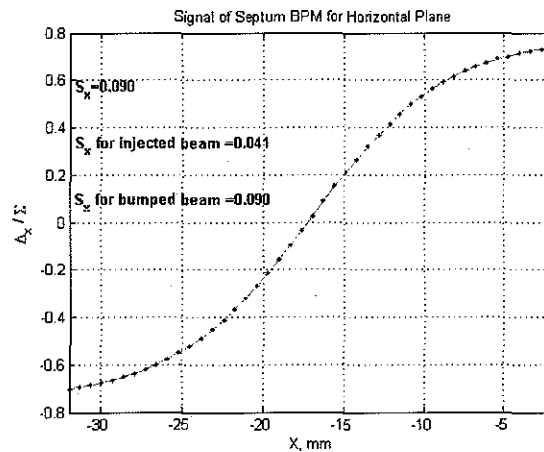

Figure 6: Sensitivity to the horizontal motion of the second BPMs.

The BPM pick-up electrodes are placed on the transfer line after the DC septum. The electrodes are mounted on the round vacuum chamber with 40 mm diameter.

## TUNING

The flags will be calibrated using the engraved fiducial marks. The second flag will have an encoder for the readback of its position.

Quadrupole centering of the regular BPMs (not in the injection straight) will provide data for the beam position in the vacuum chamber. The sensitivity of the BPMs 1 and 3 will be calibrated from the turn-by-turn data and as it was mentioned before the accuracy of the fit will be verified with the circulating bema by variation of the kicker strengths.

## CONCLUSIONS

The diagnostics equipment installed in the injection straight in combination with other diagnostic will provide

sufficient means for commissioning, troubleshooting and health monitoring of the injection system.

## REFERENCES

- [1] T.V. Shaftan et al., "Progress with NSLS-II Injection Straight Section Design," NAPAC'11, New York, 2011, THP216; <http://www.JACoW.org>.
- [2] K. Vetter et al., "NSLS-II RF Beam Position Monitor," NAPAC'11, New York, 2011, MOP211; <http://www.JACoW.org>.